

Cash Box

...ing the New Image (Ed) ...
... No 5 ...
... Fox Selling Big 3 ...
... Label Is ...
... GM...



**Please don't get the new
Mac Davis single ("I Believe in Music")
mixed up with the old Mac Davis single
("I Believe in Music").**

The Mac Davis single you received a few days ago is a spanking new production of the song Mac Davis had out a few months ago.

The old version of "I Believe in Music" was a song we admired so much, Mac went back to the studio and redid it...complete with soul chorus and driving Top-40 arrangement. The result:

A sensational new version of "I Believe in Music."

Produced by the people responsible for the Dawn and Dusk records (they were the No.2 most successful hitmakers of the past year), this is a completely new record.

It's a hit record.



**The new "I Believe in Music"
by Mac Davis. On Columbia Records** 4-45456 

GEORGE ALBERT
President and Publisher
MARTY OSTROW
Vice President
IRV LICHTMAN
Editor in Chief

EDITORIAL
CHRISTIE BARTER
West Coast Editor
ED KELLEHER
ERIC VAN LUSTBADER
KENNY KERNER

EDITORIAL ASSISTANTS
MIKE MARTUCCI
ANTHONY LANZETTA

ADVERTISING
STAN SOIFER
Advertising Manager

ACCOUNT EXECUTIVES
ED ADLUM, New York
HARVEY GELLER, Hollywood
WOODY HARDING
Art Director

COIN MACHINE & VENDING
ED ADLUM

General Manager

DON DROSSELL
CAMILLE COMPASIO, Chicago
LISSA MORROW, Hollywood

CIRCULATION
THERESA TORTOSA, Mgr.

HOLLYWOOD

HARVEY GELLER—CHRISTIE BARTER
6565 Sunset Blvd. (Suite 525), Hollywood, Calif. 90028
Phone: (213) Hollywood 9-2966

NASHVILLE

JUANITA JONES
806 16th Ave. South, Nashville, Tenn. 37203
Phone: (615) 244-2898

CHICAGO

CAMILLE COMPASIO
29 E. Madison St., Chicago, Ill. Phone: (312) FI 6-7272

ENGLAND

DORRIS LAND
3 Cork Street
London W1
Tel. 01-7342374

GERMANY

CHRISTIAN TOERSLEFF
2 Hamburg 56
Leuchtturm Weg 30
Tel: 34-91-94-86

BRAZIL

PEDRO FRAZAO
DE VASCONCELOS
Rue Frei Caneca, 11, Apt. 13
Sao Paulo, S.P., Brazil
Tel: 257-15-58

ARGENTINA

MIGUEL SMIRNOFF
Belgrano 3252, Piso 4 "B"
Buenos Aires, Argentina
Tel: 89-6796

CANADA

WALT GREALIS
RPM
1560 Bayview Ave.
Toronto 17, Ontario
Tel: (416) 489-2166

FRANCE

FRANK LIPSIK
5 Rue Alfred Dorneuil
78 Croissy
Tel: 225-26-31

SPAIN

JOAQUIN MERINO
Presidente Carmona, 11
Madrid 20, Spain
Tel. 270-2915

HOLLAND

PAUL ACKET
Theresiastraat 59-63
The Hague
Tel: B37700

ITALY

GABRIELE G. ABBATE
Viale A. Doria 10
20124 Milano

BELGIUM

ETIENNE SMET
Postbus 56
B-2700 Sint-Niklaas
Tel: (03) 76-54-39

AUSTRALIA

PETER SMITH
40 Winters Way
Doncaster 3108
Victoria, Australia

MEXICO

SALVADOR ARREGUIN
ANTONIO SENS
Tiber 100 — 7 y 8 Pisos
Mexico 5, D.F.
Tel: 525-39-52 11-62-96

JAPAN

Adv. Mgr.
SACHIO SAITO
I-II 2-Chome Shinbashi
Minato-Ku, Tokyo
Tel: 504-1651
Editorial Mgr.
FUMIYO TACHIBANA
I-II 2-Chome Shinbashi
Minato-Ku, Tokyo
Tel: 504-1651

The Promo Man: Maintaining His New Image

The record promotion man is no longer the character whose depth of intelligence was once measured by his one-liners. That image, thank goodness, has been shed by not only the bright newcomers, but many of the veterans, who have picked up on the no-nonsense (not meaning lack of good-humor) approach that establishes credibility and awareness.

Yet, we have been told lately that promotion—the basic link (and image) between the recording industry and broadcasting—is a misunderstood function, one that is costing many companies dearly in terms of hit product and others in terms of a low morale factor among its promotion force. One key promotion man puts the roots of the problem at the very top of label executive suites: "The promotion man may be talking to the president or other execs of a non-promotion-minded company, but no one is listening. They are taking the narrow view of 'how come you can't get that specific record played?' No other factors, such as the record itself, tight play lists and the long-range relationship between the promotion man and

his radio contacts, are taken into account."

What is discouraging about this front-office commentary is that it eradicates at one swipe all that is supposed to have evolved in promo man functions in recent years: an honest relationship between him and the broadcaster, thus bridging the credibility gap. A broadening of promo man activities to include regular contact with wholesale and retail establishments so that a proper level of inventory is maintained on successful product and that he gain a proper "feel" of the type of product flow in his territory.

We have no intention of downgrading the concept of getting play on records. But, won't undue pressure on that "one" record or, for that matter, every record on release damage that hard-won credibility relationship? We think labels and their promo force can do a better job by understanding the role of promotion within a broad context, one that does not rise or fall on one release. More airplay on deserving product will come of it. And, naturally better communications between the home office and its promo force.

SUBSCRIPTION RATES \$35 per year anywhere in the U.S.A., Published weekly at 34 N. Crystal St., E. Stroudsburg, Pa. by Cash Box, 1780 Broadway, New York, N.Y. 10019. Second class postage paid at New York, N.Y., U.S.A. and additional offices.

Copyright © 1971 by The Cash Box Publishing Co., Inc. All rights reserved. Copyright under Universal Copyright Convention.



CashBox TOP 100

1	SPANISH HARLEM	Aretha Franklin-Atlantic 2817	2	9
2	SMILING FACES SOMETIMES	Undisputed Truth-Gordy 7108	3	12
3	UNCLE ALBERT/ADMIRAL HALSEY	Paul & Linda McCartney-Apple 1837	9	28
4	GO AWAY LITTLE GIRL	Donny Osmond-MGM 14285	6	15
5	TAKE ME HOME, COUNTRY ROAD	John Denver-RCA 0445	1	2
6	THE NIGHT THEY DROVE OLD DIXIE DOWN	Joan Baez-Vanguard 35138	14	30
7	AIN'T NO SUNSHINE	Bill Withers-Sussex 219 (Dist: Buddah)	10	14
8	HOW CAN YOU MEND A BROKEN HEART	Bee Gees-Atco 6824	4	1
9	I JUST WANT TO CELEBRATE	Rare Earth (Rare Earth) 5031	15	18
10	WON'T GET FOOLED AGAIN	The Who-Decca 32846	13	16
11	SIGNS	Five Man Electric Band-Lionel 3213 (Dist: MGM)	7	8
12	LIAR	3 Dog Night-Dunhill 4282	8	10
13	I WOKE UP IN LOVE THIS MORNING	Partridge Family-Bell 130	17	20
14	WHAT YOU SEE IS WHAT YOU GET	Dramatics-Volt 4058 (Dist: Stax)	20	22
15	MERCY, MERCY, ME (ECOLOGY)	Marvin Gaye-Tamla 54207	5	4
16	STICK UP	Honey Cone-Hot Wax 7106 (Dist: Buddah)	19	27
17	THE STORY IN YOUR EYES—	Moody Blues-Threshold 67006 (Dist: London)	24	29
18	MAGGIE MAY	Rod Stewart-Mercury 73224	38	66
19	SUPERSTAR	Carpenters-A&M 1289	37	68
20	BANGLA DESH	George Harrison-Apple 1836	21	25
21	GO DOWN GAMBLIN'	Blood, Sweat & Tears-Columbia 45427	22	26
22	TIRED OF BEING ALONE	Al Greene-Hi 2194 (Dist: London)	26	32
23	RAIN DANCE	Guess Who-RCA 0522	27	33
24	SO FAR AWAY	Carole King-Ode 66019	39	60
25	IF NOT FOR YOU	Olivia Newton John-Uni 55281	23	24
26	RIDERS ON THE STORM	Doors-Elektra 45738	12	13
27	CHIRPY CHIRPY CHEEP CHEEP	Mac & Katie Kissoon-ABC 11306	36	44
28	SWEET CITY WOMAN	Stampeders-Bell 120	34	43
29	WEDDING SONG (THERE IS LOVE)	Paul Stookey-Warner Bros. 7511	35	42
30	SWEET HITCH-HIKER	Credence Clearwater Revival-Fantasy 665	11	5
31	IF YOU REALLY LOVE ME—	Stevie Wonder-Tamla 54208 (Dist: Motown)	41	49
32	I AIN'T GOT TIME ANYMORE	Glass Bottle-Avco 4575	40	48
33	DO YOU KNOW WHAT I MEAN	Lee Michaels-A&M 1262	42	51

34	MR. BIG STUFF	Jean Knight-Stax 0088	13	6
35	DRAGGIN' THE LINE	Tommy Jones-Roulette 7103	16	3
36	ALL DAY MUSIC—	War-U.A. 50815	43	53
37	MAKE IT FUNKY	James Brown-Polydor 14088	48	59
38	BEGINNINGS	Chicago-Columbia 45417	28	11
39	K-JEE	Nite Liters-RCA 0461	46	56
40	SATURDAY MORNING CONFUSION	Bobby Russel-U.A. 50788	44	47
41	MARIANNE	Stephen Stills-Atlantic 2820	53	63
42	CRAZY LOVE	Helen Reddy-Capitol 3138	50	58
43	STAGGER LEE	Tommy Roe-ABC 11307	52	61
44	TAKE ME GIRL, I'M READY	Jr. Walker & All Stars-Soul 35084 (Dist: Motown)	45	46
45	WAITING AT THE BUS STOP	Bobby Sherman-Metromedia 222	47	50
46	CALL MY NAME, I'LL BE THERE	Wilson Pickett-Atlantic 2824	49	52
47	TRAPPED BY LOVE	Denise LaSalle-Westbound 182	54	78
48	THIN LINE BETWEEN LOVE AND HATE	Persuaders-ATCO 6822	56	67
49	ANOTHER TIME, ANOTHER PLACE	Engelbert Humperdinck-Parrot 40065	59	70
50	I LIKES TO DO IT	People's Choice-Phil.-L.A. of Soul 349	51	55
51	SURRENDER	Diana Ross-Motown 1188	55	64
52	WHAT THE WORLD NEEDS NOW	Tom Clay-Mowest 5002	25	7
53	MAYBE TOMORROW	Jackson 5-Motown 1186	32	23
54	THE LOVE WE HAD	Dells-Cadet 5683	64	75
55	INDIAN RESERVATION	Raiders-Columbia 45332	33	34
56	ANNABELLA	Hamilton, Joe Frank & Reynolds-Dunhill 4287	66	76
57	YO-YO	Osmonds-MGM 14295	—	—
58	THE BREAKDOWN—	Rufus Thomas-Stax 0098	62	73
59	KOKO-JOE	Jerry Reed-RCA 1011	69	81
60	WHERE EVIL GROWS	Poppy Family-London 148	63	65
61	LOVING HER WAS EASIER	Kris Kristofferson-Monument 8525	70	79
62	MAC ARTHUR PARK (PART II)	Four Tops-Motown 1189	73	83
63	I'D RATHER BE SORRY	Ray Price-Columbia 45425	65	69
64	MAGGIE	Redbone-Epic 10670	60	62
65	YOU'VE GOT A FRIEND	James Taylor-Warner Bros. 7498	29	19
66	HOW CAN I UNLOVE YOU	Lynn Anderson-Columbia 45429	68	72
67	FEEL SO BAD	Ray Charles-ABC 11308	67	71

68	GIMME SHELTER	Grand Funk Railroad-Capitol 3160	71	82
69	I'VE FOUND SOMEONE OF MY OWN	Free Movement-Decca 32818	94	100
70	GET IT WHILE YOU CAN	Janis Joplin-Columbia 45433	75	85
71	NEVER ENDING SONG OF LOVE	Delaney & Bonnie & Friends-Atco 6804	30	17
72	GHETTO WOMAN	B. B. King-ABC 11310	76	88
73	A WOMAN'S LOVE RIGHTS	Laura Lee-Hot Wax 7105 (Dist: Buddah)	91	—
74	ALL MY TRIALS	Ray Stevens-Barnaby 2039	77	89
75	MILITARY MADNESS	Graham Nash-Atlantic 2827	78	—
76	STOP, LOOK & LISTEN	Stylists-Avco 4572	86	94
77	COLOUR MY WORLD	Chicago-Columbia 45417	79	86
78	WEAR THE RING	Detroit Emeralds-Westbound 181	82	95
79	DESEMOMONA	Searchers-RCA 0484	81	87
80	CAN YOU GET TO THAT	Funkadelic-Westbound 185	83	—
81	EASY LOVING	Freddie Hart-Capitol 3115	89	98
82	ONE FINE MORNING	Lighthouse-Evolution 1048	—	—
83	A NATURAL MAN	Lou Rawls-MGM 14262	85	93
84	THAT'S THE WAY A WOMAN IS	Messengers-Rare Earth 5032 (Dist: Motown)	—	—
85	IS THAT THE WAY	Tin Tin-Atco 6821	88	—
86	STONE OF YEARS	Emerson Lake & Palmer-Cotillion 44131	—	—
87	HANDBAGS & GLADRAGS	Chase-Epic 10775	—	—
88	ONE TIN SOLDIER	Coven-W.B. 7509	—	—
89	THINK HIS NAME	Johnny Rivers-U.A. 50822	100	—
90	DON'T TRY TO LAY NO BOOGIE WOOGIE ON THE KING OF ROCK & ROLL	John Baldry-W.B. 7506	90	99
91	HE'D RATHER HAVE THE RAIN	Heaven Bound with Tony Scotti-MGM 14284	93	97
92	CALIFORNIA KID AND REEMO	Lobo-Big Tree 119	—	—
93	BLACK SEEDS KEEP ON GROWING	Main Ingredient-RCA 0517	92	—
94	A PART OF YOU	Brenda & Tabulations-Top & Bottom 409	96	—
95	A SONG FOR YOU	Andy Williams-Columbia 4-45434	95	96
96	ROLL ON	New Colony Six-Sunlight 1001	98	—
97	HIJACKIN' LOVE	Johnnie Taylor-Stax 0096	—	—
98	YOU'VE GOT TO CRAWL	8th Day-Invincible 9098	—	—
99	ALL MY HARD TIMES	Joe Simon-Spring 118	—	—
100	THE YEAR THAT CLAYTON DELANEY DIED	Tom T. Hall-Mercury 73221	—	—

ALPHABETIZED TOP 100 (INCLUDING PUBLISHERS AND LICENSEES)

Annabella (Dunbar—BMI)	56	Marianne (Gold Hill—BMI)	41	Surrender (Jobete Music—BMI)	51
Another Time (MCA—ASCAP)	49	Maybe Tomorrow (Jobete—BMI)	53	Sweet City Woman (Coral Music—BMI)	28
Bangla Desh (Harrisons—BMI)	20	Mercy, Mercy, Me (Jobete)	15	Sweet Hitch-Hiker (Greasy King—BMI)	30
Black Seeds Keep (Ingredient Music—BMI)	92	Military Madness (Giving Room Music—BMI)	75	Take Me Girl, I'm Ready (Jobete—BMI)	44
Breakdown (East Memphis Music—BMI)	58	Mr. Big Stuff (Malaco—BMI)	34	Take Me Home (Lane—ASCAP)	5
California Kid (Ensign—BMI)	92	Natural Man (Beresofsky—Herb—BMI)	83	That's The Way (Stein/Van/Positive—ASCAP)	84
Call My Name (Walden Music)	46	Never Ending Song Of Love (Metric—BMI)	71	The One For (Gaucho Music—BMI)	47
Can You Get To That (Bridgeport Music—BMI)	80	Night They Drove (Canaan Music—ASCAP)	6	Think His Name (Music Pushers—ASCAP)	89
Chirpy Chirpy (Interson USA—ASCAP)	27	One Fine Morning (C.M.A.—USA—BMI)	82	Tired Of Being Alone (Jec—BMI)	22
Colour My World (Aurelius Music—BMI)	77	One Tin Soldier (Cents & Pence—BMI)	88	Thin Line Between Love & Hate (Cotillion)	48
Crazy Love (Van-Jay/W.B. Music—ASCAP)	42	Part Of You (One Eye Soul—BMI)	94	Win Or Lose—BMI)	48
Desdemona (Belwyn-Mills—ASCAP)	79	Rain Dance (Circus/Sunspot/Dunbar—BMI)	23	Trapped By Love (Bridgeport/Ordena—BMI)	47
Do You Know (La Brea Music/Sattwa—ASCAP)	33	Riders On The Storm	26	Uncle Albert (Maclean—BMI)	3
Don't Try To Lay (Hastings—BMI)	90	Roll On (New Colony—BMI)	96	Waiting At The Bus Stop (Wally—ASCAP)	45
Draggin The Line (Big 7—BMI)	35	Saturday Morn (Pix, Russ—ASCAP)	40	Wear This Ring (Bridgeport—BMI)	78
Easy Loving (Blue Book—BMI)	81	Signs (4 Star—BMI)	11	What The World (Blue Sea/Jac—ASCAP)	52
Feel So Bad (Arc/Playmate—BMI)	67	Smiling Faces Sometimes (Jobete—BMI)	2	What You See (Groovesville—BMI)	14
Get It While (Hill & Range/Ragmar)—BMI	70	So Far Away (Screen Gems/Col.—BMI)	24	Where Evil Grows (Gone Fishin'—BMI)	60
'Ghetto Woman' (Pemco Music—BMI)	72	Song For You (Sky Hill—BMI)	95	Wedding Song (P. D. Foundation—ASCAP)	29
Gimme Shelter (ABKCO Music—BMI)	68	Spanish Harlem (Progressive-Trio—BMI)	1	Woman's Love Rights (Gold Forever Music—BMI)	73
Go Away Little Girl (Screen Gems/Col.—BMI)	4	Stagger Lee (Travis Music—BMI)	43	Won't Get Fooled (Track—BMI)	10
Go Down Gamblin' (Blackwood/Minnesinger—	4	Stick Up (Gold Forever—BMI)	16	Year That Clayton (Newkeys—BMI)	100
		Stone Of Years (Tro-Total—BMI)	86	You've Got (Screen Gems/Col.—BMI)	65
		Stop, Look (Bellboy/Assorted—BMI)	76	You've Got To Crawl (Gold Forever—BMI)	98
		Story In Your Eyes (Tro-Cheshire—BMI)	17	Yo Yo (Lowery—BMI)	57
		Superstar (Sky Hill/Delbone)	19		

**A unique
new
Pop/Rock sound...**

SPRINGWELL



IT'S FOR YOU

**A fast-breaking new single. It's a hit in Detroit.
And the action is spreading - Cleveland, Toronto,
Seattle, Buffalo, Syracuse.**

359



Produced by Pink Unlimited & Vinny Testa

the james gang

has a
new single

midnight man

abc-11312

and a
new album

james gang / live in concert

Stop / You're Gonna Need Me / Take A Look Around
Tend My Garden / Ashes, The Rain & I / Walk Away / Lost Woman



live in concert abcx-733

and they're
**OUR
GANG!**

ABC/DUNHILL RECORDS



Certron Sues, Singleton Answers Charges

NASHVILLE — Shelby Singleton has been ordered to appear at a hearing here this week (10) to show cause why a receiver should not be appointed to operate and liquidate Shelby Singleton Corp. and its affiliates.

The order, by Chancellor Ned Lentz, is an outgrowth of a suit by Certron Corp. seeking to recover \$57,732 the company says is due for tape cartridge duplication and distribution services.

Singleton, in turn, has refuted the charges and allegations made in the complaint by Nashville attorney W. B. Earthman. Singleton claims that figures quoted were in error, nor did they reflect the damage complaints against the Certron Corp. for delivery of inferior product.

Responding to allegations concerning the closing of several divisional companies owned by SSC, it was noted that recent recommendations by auditing and business advisors have resulted in the dissolution of 32 subsidiary companies and/or corporations. Since July 1, all suppliers, the company stated, have been notified by mail that the parent corporation would be responsible for all debts. Additionally, proposals were reportedly made for the amortization of any past due obligations.

New Stereo Cartridge System From Japan

See
Tape Report

FRONT COVER:



Led Zeppelin is currently undertaking its biggest, most triumphant tour of the U.S., resulting in a complete string of sellout dates. The group—Jimmy Page, Robert Plant, John Paul Jones and John Bonham—will wind up its present trip in Hawaii on Sept. 16. The group's fourth Atlantic album will be released shortly, all three of their previous LP's having been awarded RIAA-certified, gold disks.

INDEX

Album Reviews	25, 29
Coin Machine Section	42-46
Country Music Section	34-39
Insight & Sound	22, 32
Looking Ahead	20
New Additions To Playlist ..	14, 16
Radio Active Chart	12
Radio News Report	12
R&B Top 60	27
Single Reviews	18
Talent On Stage	31
Tape News	16
Top 100 Albums	27
Vital Statistics	20

3 Dog Night Mgr: Concert Pact Stipulation—No Security, No Performance

HOLLYWOOD — Burt Jacobs, manager of 3 Dog Night, is adding a rider to all future contracts with promoters stipulating that he must be satisfied with their security precautions or the group won't play—an industry first for this kind of action.

According to Jacobs, no matter who the promoter is, "I want to know who's handling security and, more important, how they're going to handle it."

His move on behalf of 3 Dog Night results from a serious disturbance at the San Diego Sports Arena a week ago on Sunday, Aug. 29, when the group followed Osibisa on stage after the break. "It took only 90 seconds," says Jacobs, "but about four or five hundred kids came storming up front right after the group started to play. It was the first time I've ever really been frightened—and I've been through some 260 shows of this kind. But a lot of young people

got soaked around, a number of them really got hurt, and I saw at least one being carried out on a stretcher. We had to stop the show six times."

The real danger, Jacobs emphasizes, is that people can and do get hurt when this kind of minority action prevails. "And just because the promoter thinks he can save a couple of bucks by cutting corners on security," he adds.

Proving his point that it is purely a matter of insufficient training on the part of security personnel, and insufficient numbers as well, Jacobs points out that just prior to the San Diego date Three Dog Night had played the Salt Palace in Salt Lake City to the same size audience (some 14,500) without incident. "By the time the show was over the guards themselves were dancing and the kids were grooving with them. But first and foremost those guards knew

(Cont'd on p. 30)

Geffen's Asylum Co. Teamed With Atlantic Label Family

NEW YORK—David Geffen's new Asylum label will be a joint venture between the manager and Atlanta Records. It will form the fourth label of the present Atlantic Atcol Cotillion group.

Geffen, who manages Crosby, Stills, Nash & Young, Joni Mitchell and Laura Nyro, has lined up the following acts for Asylum: Joni Mitchell, Jackson Browne, Judee Sill, David Blue, Jo Jo Gunne, Steve Ferguson, John David Sauter, Ned Doheny and a new and as yet unnamed group consisting of Glen Frey (formerly of Long Branch Penny-whistle), Bernie Leadon (formerly of the Flying Burrito Brothers), Randy Mizner (formerly of Poco) and Don Henley. Other signings will be announced shortly.

Ahmet Ertegun, president of Atlantic, said, "We are very pleased to announce formation of Asylum Records with David Geffen. Over the past three years he has built an enviable reputation as a manager of outstanding talent. During that period he has been responsible for the sales of over 8 million records. We believe he will be very successful with Asylum, which is one of the most important labels ever started by Atlantic. With the talent on its roster, Asylum is a major label from its inception."

First releases on Asylum Records will be issued Sept. 15. They include LP's by Judee Sill, Jo Jo Gunne, Jackson Browne and David Blue. Judee Sill's album will be rush-released as she is a featured per-

former with the David Crosby-Graham Nash tour that begins Sept. 10.

Asylum will be helmed by Geffen as president, with headquarters in Los Angeles. Most of the recording is taking place on the West Coast. The firm intends to issue two or three LP's a month for the rest of the year. Asylum will have its own promo men and will work with Atlantic promo staffers.

Sept. Aretha Month At Atl.

NEW YORK—Atlantic Records has declared September "Age of Aretha" month. The company has mapped out a promo, advertising, and in-store campaign over the entire month.

Kicking off the campaign will be the release of an "Aretha's Greatest Hits" album which features her biggest singles, including "Bridge Over Troubled Water" and "Spanish Harlem", both million sellers. Also already in the works is a strong radio advertising program that will cover most of the major markets with AM radio spots, and ads in the music trade papers.

In-store selling aids will include a specially designed point of sale poster created under the supervision of Atlantic's Sales department that will spotlight the nine Aretha Franklin albums on the label including the "Greatest Hits" LP and "Aretha Franklin Live At Fillmore West," which was recently RIAA certified for selling a million dollars in LP's.

The performer was voted "Top Female Vocalist" by the National Association of Television and Radio Announcers (NATRA) at its annual convention held recently in Chicago.

Auslander Elected E. B. Marks Pres.

NEW YORK — Joseph Auslander has been elected president of E. B. Marks Music. He replaces Herbert Marks, son of the oldline publishing company's founder. He had served as president since 1945. Auslander, associated with the company for 20 years, most recently as vp and general manager, was elected by the company's board of directors at a meeting last Monday (30). Marks will continue to serve the corporation as a member of the board, with Auslander assuming full responsibilities as chief exec officer.

20th Selling Big 3 Interest Back To Metro

NEW YORK—20th Century-Fox' minority (32.3%) interest in Big 3 Music (Robbins-Feist-Miller) is being sold back to Metro-Goldwyn-Mayer, Inc., chief stockholder in the giant music publishing complex.

20th said it had agreed to sell its share for \$4.5 million. The company had originally acquired this interest for \$688,000 in 1947.

The sale, explained Dennis C. Stanfill, president of 20th, in "no way reflects any diminution of interest in our music publishing activities, rather it will now permit us to devote our full energies to the development of our wholly owned music-publishing subsidiaries."

20th also noted that, after giving effect to Federal income tax carry-forward on the sale profit—which amounts to \$3,832,000, or 45c a share—there will be no tax payable on the profit, and that it would be reported as an extraordinary gain in the third quarter."

WB Folios To Col Disk Club

NEW YORK—Ed Silvers, president of Warner Bros. Music Publishing, has announced a precedent-setting agreement with the Columbia Record Club for distribution of Warner Bros. song folios. Promo mailing pieces are now being prepared which will offer members of the Club eleven Songbooks from the WB folio catalog including: Peter, Paul & Mary Deluxe Guitar Book; Peter, Paul & Mary Deluxe Piano Vocal Songbook; Janis Joplin's "Pearl"; Bob Dylan's Deluxe Songbook; The Songs of Elton John and Bernie Taupin; Crosby, Stills, Nash & Young; Woodstock; Laura Nyro; Neil Young; and Paul McCartney's "Ram". Four Simon and Garfunkel books, not published by WB, will also be included in the initial offer.

The deal was initiated by Silvers and Michael Tanne, attorney for Simon & Garfunkle and negotiated with Neil Keating, president of Columbia House, and Bill Bell, vice-president of music marketing, representing the Columbia Record Club.

"We anticipate that this additional avenue of distribution to the Club's million-plus membership should increase our folio sales by an approximate half million annually," said Silvers.

Wiedenmann Is Metromedia GM

NEW YORK — Jack Wiedenmann has been named general manager of Metromedia Records, according to Tommy Valando, president of Metromedia Music, Inc. Wiedenmann recently left Famous Music Corp. as exec vp. Wiedenmann's music business career also covers key posts at Columbia Records and MCA Records, where he headed Kapp Records and held a sales vp post at Decca.



Wiedenmann



Wishbone Ash
Pilgrimage

DL 75295



EXCLUSIVELY ON **DECCA**

Buddah/Kama Sutra Group Sets 9 Albums In 'Stage One' Push

NEW YORK — "Stage One" of the Buddah/Kama Sutra Group's fall product package consists of nine albums.

"By the end of 1971," note Neil Bogart and Art Kass, co-presidents, "with the 'Second Stage' of our fall product in release, Buddah/Kama Sutra will have presented the strongest and most diversified album product in its history..."

Heading off is the Isley Brothers' "Givin' It Back" set, including their top ten version of "Love The One You're With" and their new single, "Spill The Wine". The LP concept is the Isleys' "friendly" reply to the many artists—from The Beatles to Blood, Sweat & Tears—who have recorded Isley material and been influenced by them. The LP appears on the Isleys' T-Neck Records label, distributed by Buddah.

On Kama Sutra, Buzzy Linhart bows in with, "The Time To Live Is Now," featuring his version of his own "The Love's Still Growing," a hit for Carly Simon, plus new Linhart material. He's backed by Bill Takas on bass and Luther Rix on drums (both formerly of Ten Wheel Drive).

Exuma, the "Obeah Man," debuts on Kama Sutra with "Doo Wah Nani". Sidemen on the new LP include Lord Wellington, Lord Cherry, Daddy Ya Ya and Sally O'Brien on referee's whistle.

Dust is a three-man hard rock group discovered and produced by Dominic Sicilia. They have been together for six years, working various

Sachs To TRO As Record Chief

NEW YORK—Len Sachs will head up record operations for The Richmond Organization and will coordinate the U.S. releases and exploitation of masters produced by the Essex Music Group in England.

Under a newly augmented record product development program report by Howie Richmond, president, Sachs will represent international matters for David Platz, head of the Essex Music Group. Sachs will assist in negotiations and coordinate distribution and releases of British produced masters in the U.S. He departs immediately for London to meet with David Platz and the Essex Group record production personnel.

Essex Music Group artists currently active in the U.S. include Joe Cocker on A & M, T. Rex on Warner Bros., Black Sabbath on Warner Bros., John Kongos on Elektra, Ralph McTell on Paramount, Michael Chapman on Capitol, Third World War on CBS, John Williams on CBS, and Wally Whyton on Amsterdam.

TRO Workshop Productions here will expand activities under Sachs' direction to include record production, distribution and the acquisition of USA artists and masters. Sachs' projects will be available to all labels including TRO subsidiary labels.

Sachs, former vice president and director of marketing at Atlantic Records, has had wide experience in all phases of the current record scene.



Sachs

clubs in the New York area. "From A Dry Camel" is their first album.

Buddah debuts a quartet of albums, leading off with "Gotta Get Back To Cisco" by Gorgoni, Martin & Taylor. This is the first appearance as artists for Chip Taylor, Al Gorgoni and Trade Martin, who have scored as writers, producers and sidemen. Gorgoni and Taylor produced the first recordings by James Taylor on Rainy Day Records in 1969.

Bobbi Martin, of "For The Love Of Him" fame, bows in with "Tomorrow," titled after her new single. LP features several Martin tunes co-penned with collaborator and producer Henry Jerome. The team worked together on "For The Love Of Him," "Don't Forget I Still Love You" and "I Love You So". The new album also contains her version of "No Love At All."

"The Johnny Maestro Story" is a retrospective album that traces the careers of Maestro with The Crests (Cont'd on page 30)

RCA 'Music Service' Division Realigns Club, Premium Units

Heneberry Chief

NEW YORK — RCA Records has aligned its Record and Tape Clubs and its Premium, Educational, and Custom activities in a new organization called RCA Music Service.

Dave Heneberry, formerly vice president of the Record Club, becomes vice president of RCA Music Service and heads the new activity.

Rocco Laginestra, president of RCA Records, noted that there are many similarities between the activities of the Clubs and Premium Department. "This new alignment will strengthen both activities," he added.

"Under this re-alignment," said Heneberry, "the departments will continue to function as separate entities and we will be able to call on each other's expertise."



Heneberry

Holzman Back In Studio w/ Quinames Band

NEW YORK—Elektra president Jac Holzman returned to the recording studio recently after a three-year absence to co-produce The Quinames Band's debut LP with Bob Zachary for the label.

Holzman who turned Elektra into a \$10 million company and recently oversaw its merger with Kinney Services last produced in 1967, an album entitled "The Zodiac Cosmic Sounds." The Quinames Band is a quintet whose collective experiences have seen them play as part of James Taylor's Flying Machine, The Fifth Avenue Band, The Myddle Class and Jake & The Family Jewels before forming their new group.

The increased duties of administration of Elektra have kept Holzman away from an active studio production schedule which helped establish the label in its initial stages.

Full Scale Promo, Execs On Road Back 8 Bell Packages

NEW YORK—Bell Records, eight LP lineup of Fall releases will be backed by full-scale promo, sales and publicity campaigns.

Underscoring the importance of the new LP releases are the personal visits being made by key Bell execs to introduce the albums to distributors. From New York, vice president of LP sales Gordon Bossin and vice president Oscar Fields plus west coast general manager John Rosica will go on the road to meet distributors and distributor salesmen in many major markets.

Explained Bossin: "We've found it important to make personal contact with our distributors and their salesmen at regular intervals, especially when we have a major release scheduled. Better results are achieved from face-to-face meeting between our key operating personnel and the men in the field. We can get a realistic, on-the-spot assessment of the situation in each area and we can evaluate local problems at close hand."

Recent chart singles which will be included in Bell albums this fall are "Never My Love" by the 5th Dimension, from their new live album recorded in Las Vegas, "Summer Sand" by Dawn, "Rainy Jane" by Davy Jones and "Sweet City Woman" by the Stampede. Other highlights of the new LP releases are: a comedy album revealing the foibles of the "Jewish-American Princess," by the producers of the First Family; the 5th Dimension's "Reflections," a collection of their past hit songs; the first Christmas LP from the Partridge Family; and a Christmas album featuring TV host David Frost and bandleader Billy Taylor.

"This is by far the most impressive album release since we began concentrating on LP product a year and a half ago," said Bossin. "Every one of these records has unlimited chart and sales potential and we'll be giving them our complete support."

Bienstock Buys Quintet Music

NEW YORK—Freddy Bienstock has acquired from Hill and Range Songs total interest in Quintet Music. The company's extensive catalog includes rock classics such as "Love Potion #9," "Riot In Cell Block Number Nine," "Goodnight My Love" and "Smokey Joe's Cafe," to mention but a few. By virtue of Quintet's 60% ownership of Tiger Music, the company also holds title to additional copyrights. Some of them, made famous by The Coasters' string of hits are "Charlie Brown," "Yackety Yak," "Along Came Jones," "Searchin'," "Young Blood" and "Poison Ivy."

Jerry Leiber and Mike Stoller, composers of many of the company's songs, retain their joint 50% interest in Quintet as well as their identical ownership in The Hudson Bay Music Co. with Bienstock.

Jerry Fuller To Produce For Bell Label

HOLLYWOOD — Jerry Fuller will produce recordings for Bell Records under a long-term production agreement, according to Larry Uttal, president of the label, and Fuller.

Fuller will bring in new talent to Bell and continue to engage in a limited number of outside productions. Fuller recently left the staff A&R position he held at Columbia Records over the past four years to establish his own company, Moonchild Productions, Inc.

At Columbia, the vet producer-writer produced sessions by Mac Davis, Mark Lindsay, Gary Puckett and the Union Gap, Andy Williams and O. C. Smith. Four of his LP's and six singles earned RIAA-certified gold record awards.

Said Fuller of the Bell deal: "... Larry Uttal's total involvement with every facet of his organization guarantees that all of our product will derive the benefits of his personal participation. In particular, I greatly admire the complete creative autonomy that Bell Records gives to its producers."



Fuller, Uttal

Counterclaim By Sperber: \$40 Mil Suit

NEW YORK — Betty Sperber and the Original American Touring Company have filed counterclaims for \$40 million in damages against the Robert Stigwood Group Limited, Leeds Music Limited and Leeds Music Corp. after Mrs. Sperber and the Original American Touring Company were granted the right to perform musical selections from "Jesus Christ Superstar" when Judge Lawrence W. Pierce of the U.S. District Court for the Southern District of New York denied the Stigwood group's request for an injunction against their performances.

In answer, through attorney Robert I. Fitzpatrick, to the Stigwood complaint for alleged copyright infringement which had been filed earlier this month, Mrs. Sperber alleged that the Stigwood Group and their co-plaintiffs, Leeds Music Limited and Leeds Music Corporation, "and particularly their attorneys, John L. Eastman, Abeles and Clark, Robert Osterberg and John Clark, wrongfully, corruptly and deliberately inter-

(Cont'd on page 30)

TIC 5 Month Losses: \$4.8 Mil

NEW YORK — Transcontinental Investing Corp. has reported a net loss of \$4,875,000 on sales of \$37,240,000 for the five months ended May 31. During 1970, the company had a net loss of \$5,598,000.

TIC said its losses mainly stemmed from losses, reserves and non-recurring expenses in the Transcontinental Music Corp., while profits were registered over the past 17 months in finance and real-estate.

Bob Lifton, chairman, said that difficulties at TIC "proved to be greater than anticipated, but we believe the major problems are now behind us."

Belwin-Mills Boom In Print Div.

NEW YORK — A year-old print music program at Belwin-Mills Publishing Corp. has reaped what Martin Winkler, its president, terms "probably the largest and most complete exploitation of the pop scene in the history of publishing."

During this period, the firm has put into print for marching band, elementary band, large concert band,

string orchestra and chorus such tunes as "Never Can Say Goodbye," "My Cherie Amour," "United We Stand," "Little Drummer Boy," "You've Made Me So Very Happy," among many others. There have also been publications for home use and folios for voice and piano or guitar.

The program of music for schools also includes a complete half-time football show called "The Sound of Young America," including top songs from the Jobete catalog, a complete script, a wide variety of formations, all necessary instructions to the conductor and 104 parts.

For fall release, the firm is planning a book of 125 Jobete songs that have reached the Top 10 over the past 11 years. Photos of Motown artists and a complete discography will be included. Grosset & Dunlap will be the exclusive distributors to the book trade.

Belwin-Mills is exclusive distributor to the music trade of Great Songs of the Sixties. First brought out in hard cover at \$17.95 list, it has sold more than 40,000 copies. An soft-cover edition, issued last April, has sold 26,000. The company expects sales of 100,000 after two years of publication.

Because of this growth picture—which does not include numerous educational and serious music efforts—Belwin-Mills will be moving in Nov. to a new building in Melville, Long Island. This building will be a single story operation containing 200,000 square feet. Winkler says its the largest installation in the world that handles printed products. Belwin-Mills will continue to operate its New York City office for its pop and rental divisions.

Settler RCA Sales Veep

NEW YORK — Eugene B. Settler has been appointed vice president of commercial sales at RCA Records.

Mort Hoffman, vice president of commercial operations, to whom Settler will report, said: "In the eight months since Settler joined RCA Records as Director of Sales, his personal leadership has had a tremendous impact on the growth of the company's commercial sales. In addition, he has been invaluable in initiating a greatly strengthened distribution set-up for the company. This promotion is recognition for the successful job he has done, and I am confident with Settler in this key job, our position in the recording industry will become increasingly stronger in the period ahead."

Settler came to RCA Records from Epic Records in Jan. of this year. He had been Director of Sales at Epic since Oct. 1968. He had joined CBS in 1965 as Columbia Records' branch manager for northern Ohio and eastern Pennsylvania. Prior to that, in 1954, after leaving Loyola University of Baltimore, he joined Edge Ltd. as Baltimore sales manager for that rack merchandising firm.



Settler

Stone Phone

NEW YORK—Dick Stone, who recently left Famous Music, can be reached at the following telephone number: (516)-432-6914.



GOING SOLO is ex-Ten Wheel Drive lead singer Genya Ravan. She's shown here with Columbia Records president Clive Davis as she signs contracts that make her the label's newest solo singer acquisition. "Anyone who witnessed her work with Ten Wheel Drive knows that Genya Ravan is among the most exciting performers in rock today," commented Davis. "Her emergence as a solo artist is certain to bring her a whole new level of recognition."

Weinstein Named VP At Bell Label

NEW YORK — Larry Uttal, President of Bell Records, today announced the promotion of Beverly Weinstein to Vice President in charge of Production and Creative Services for the label.

Miss Weinstein, has been with Bell seven years, serving as production manager and office manager. She was appointed art director at the time when Bell mounted a full scale campaign to establish itself in the LP business and has directed the label's efforts in the area of cover designs, graphics and photography.

As production manager, she directs and co-ordinates all production functions and is in close contact with the printers, fabricators and record pressers.

Prior to coming to Bell, Miss Weinstein was with Canadian American Records for several years, where she was production co-ordinator. She is a graduate of C.C.N.Y.

"From the moment Bell started, Beverly Weinstein has contributed enormously to virtually every aspect of our growth and success. She makes a valuable addition to Bell's top-level executive team," said Uttal.



Weinstein

Brambila To Ivy Hill Litho

NEW YORK—Art Brambila has been appointed customer relations coordinator for the west coast for Ivy Hill Lithograph Corp. Formerly a marketing exec with Capitol, Brambila will report to Russell Muir, exec vp of the company's Pacifica Division.

Dearborn To RCA Record Operations

NEW YORK — W. H. (Bill) Dearborn has been appointed director of record operations at RCA Records, according to Rocco Laginestra, president, to whom Dearborn reports.

Dearborn will have charge of all RCA Records' recording, warehousing and manufacturing facilities in the United States and will provide manufacturing and engineering direction on a global basis.

"The continued internationalization of our operations as well as the growing complexities of the recording industry here in the U.S. mandate that we have one man, responsible directly to me, solely in charge of our physical operations," Laginestra said.

Domestic facilities which come under Dearborn's supervision include recording studios in New York, Nashville, Chicago and Hollywood; research and engineering headquarters in Indianapolis, Hollywood and Rockaway, N.J., and office locations in New York, Nashville, Chicago and Hollywood.

At the same time, Laginestra said that Harry Jenkins, vice president, who had been in charge of record operations as well as country music A&R, will now be able to direct his full attention to maintaining and strengthening RCA's position in the country field as well as supervising RCA's activities involving the new Grunt label formed last month by Jefferson Airplane.

"We are at a time," Laginestra said, "when the recording industry embodies a growing number of product formats—LPs and 45 rpm records, Stereo 8 and Q-8 cartridge tapes and cassettes. Looming on the horizon are 4-channel records and videocassettes. It is a period when all our facilities have to undergo almost continuous modernization merely to keep pace with the changing industry. Dearborn's excellent experience and performance make him the ideal executive to direct these activities."

Dearborn, who joined RCA in 1950 as a Record Engineer in Standards and Packaging in Indianapolis, had been Manager, Manufacturing and Engineering in New York since 1968. For four years prior to that, he had been Manager, Indianapolis Record Plant, and for the last three of those years was manager of the Indianapolis Tape Plant as well. Prior to those positions, he had held increasingly important managerial positions at the RCA Indianapolis recording complex.

Klein Comments On Stones' Suit

NEW YORK—In response to the New York lawsuit by the Rolling Stones against ABKCO Industries, Inc., Allen Klein and others, Klein has stated as follows:

"The attorneys for the other defendants including ABKCO Industries, Inc. have not had a reasonable opportunity to study the complaint, which was served only yesterday (Sept. 1, 1971). ABKCO, however, in connection with its nine month earnings report issued on August 17, 1971 denied any impropriety in their dealings with the Rolling Stones and further declared that they believed the Rolling Stones' lawsuits to be without merit. Speaking only for myself, however I believe the allegations are at best ludicrous, and at worst, malicious. The transactions apparently now complained of by the Stones, date back to 1965 and 1966, and such transactions, including ownership of American Nanker Phelge Music, Ltd. and Gideon Music, Inc. were fully disclosed to them at the relevant times and also to their independent advisors, whom the Stones have frequently changed. Moreover, in the proxy statement issued in connection with the acquisition in 1968 of Allen Klein and Company, Inc. by Cameo Parkway Records, Inc., now ABKCO, the ownership of these companies and the various contractual relationships between these companies and the Stones were fully and publicly disclosed. The Stones, according to newspaper stories, have recently dropped out of England to live in France for tax reasons. Apparently, the New York and English lawsuits are an attempt to rewrite both history and their agreements in order to bludgeon ABKCO into accelerating, during this dropout period, the balance of the guarantee payments due them over the next 17 years. These long term guarantees presently are in excess of \$3 million, subject to various offset for loans and advances made to them."

We are celebrating
ARETHA FRANKLIN MONTH

with
 a brand new
 collection
 of her
 Greatest Hits

SPANISH HARLEM • BABY, I LOVE YOU • (You Make Me Feel Like) A NATURAL WOMAN
 DON'T PLAY THAT SONG • DR. FEELGOOD • LET IT BE • DO RIGHT WOMAN- DO RIGHT MAN
 RESPECT • CHAIN OF FOOLS • I SAY A LITTLE PRAYER • BRIDGE OVER TROUBLED WATER
 I NEVER LOVED A MAN (The Way I Love You) • YOU'RE ALL I NEED TO GET BY • CALL ME

Aretha's Greatest Hits



ATLANTIC RECORDS
 SD 8295

SD 8295

to add to her
 collection
 of best-selling
 Atlantic
 albums.

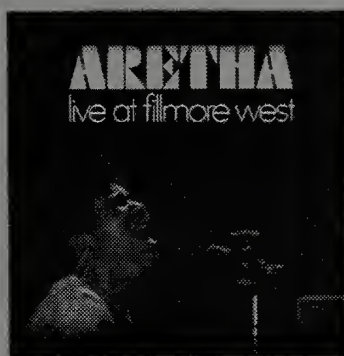

SD 7205



SD 8186

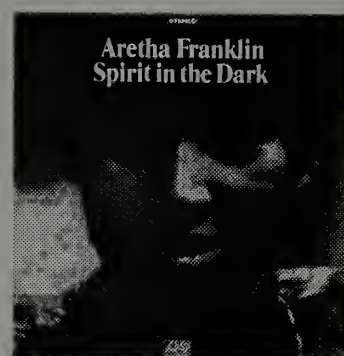

SD 8265



SD 8248



SD 8212



SD 8227



SD 8176



SD 8150



SD 8139



A survey of key radio stations in all important markets throughout the country to determine by percentage of those reporting which releases are being added to station play lists this week for the first time and also the degree of concentration combining previous reports. Percentage figures on left indicate how many of the stations reporting this week have added the following titles to their play list for the first time. Percentage figures on right include total from left plus the percentage title received in prior week or weeks.

TITLE	ARTIST	LABEL	% OF STATIONS ADDING TITLES TO PROG. SCHED. THIS WEEK	TOTAL % OF STATIONS TO HAVE ADDED TITLES TO PROG. SCHED. TO DATE
1. Yo Yo—Osmond Bros—MGM			46%	69%
2. Birds Of A Feather—Raiders—Columbia			43%	51%
3. Never My Love—5th Dimension—Bell			39%	39%
4. One Fine Morning—Lighthouse—Evolution			36%	79%
5. I'm Coming Home—Tommy James—Roulette			31%	31%
6. Roll On—New Colony 6—Sunlight			28%	34%
7. If You Really Love Me—Steve Wonder—Tamla			25%	97%
8. Wedding Song—Paul Stookey—W.B.			24%	93%
9. Trapped By Love—Denise LaSalle—Westbound			21%	21%
10. MacArthur Park—4 Tops—Motown			19%	63%
11. Bend Me, Shape Me—Storm—Sunflower			18%	18%
12. California Kid & Reemo—Lobo—Big Tree			16%	48%
13. Someone Of My Own—Free Movement—Decca			15%	94%
14. Loving Her Was Easier—Kris Kristofferson—Monument			14%	91%
15. Gypsys, Tramps & Thieves—Cher—Kapp			12%	25%
16. Is That The Way—Tin Tin—Atco			11%	25%
17. Crazy Love—Helen Reddy—Capitol			11%	68%
18. Some of Shelly's Blues—Nitty Gritty Dirt Band—V.A.			10%	19%
19. It's For You—Springwell—Parrot			9%	9%
20. Lord Have Mercy—Black Oak Arkansas—Atco			8%	19%

ALBUMS

- Barbra Joan Streisand—Columbia
- James Gang Live In Concert—ABC
- Another Time, Another Place—Engelbert Humperdinck—Parrot

Poppy Records is happy to announce that we are no longer associated with **RCA.**

And even happier to announce that we are associated with **United Artists.**

FCC's Wells To Keynote Gavin Radio Meet

SAN FRANCISCO—Commissioner Robert Wells of the Federal Communications Commission will present the opening address at the sixth annual Radio Program Conference, according to Bill Gavin, founder-director of the non-profit event, set for November 11-14 in New Orleans.

Wells is scheduled to speak Friday morning, Nov. 12, at the Roosevelt Hotel, where some 1,000 broadcast and recording industry executives are expected.

Presentations and panels over three days will deal with government involvement in broadcasting, program management, new directions in music, and allied subjects. Program committee chairman is Ted Atkins, program director, KHJ, Los Angeles.

Wells, first appointed to the FCC by President Nixon in 1969, was subsequently named by the President to a second term, expiring in 1977.

He had been general manager of the Harris Radio Group, comprising

Lawrence Hike Nets \$

LOS ANGELES—A three day, 28 mile walk through Death Valley by KLAC air personality Jay Lawrence has raised more than \$45,000 for the Foundation for Junior Blind. The amount was pledged by listeners during the on-air radiothon conducted over the three days of the disk jockey's hike. The foundation provides help and care for 800 blind children.

STATION BREAKS:

Irving Ivers, general sales mgr. of KFRC-San Francisco, has been named general sales mgr. of KHJ-AM in Los Angeles . . . Denny Long music director slot at WCCO in the same town.

Benjamin McKeel, former national sales mgr. for WHTN-TV, Huntington, West Va., appointed general sales mgr. for WLWT-TV, Avco Broadcasting's flagship station in Cincinnati. He replaces Ray Colie, who was recently promoted to general mgr. of WLWD-Dayton.

Bob Sirott to announcer slot at WBBM-FM, Chicago. He was previously public service director and promotion director at WMAQ-Chicago. . . Joe Wright, Jr. named sales mgr. of WKIX-Raleigh, N.C. . . New general mgr. at WBBF-Rochester, N.Y. is Jay Epstein.

eight stations, in Burlington and Fairfield, Iowa; Topeka, Kansas; Joliet, Ill.; and Greeley, Colorado.

Complete information is available from the Conference headquarters, 114 Sansome Street, San Francisco, California 94101.



ASCAP STORY—Kicking off the new series of taped interviews with ASCAP writers, veteran Los Angeles disk jockey Bill Stewart interviewed ASCAP composer and board member Henry Mancini. The tapes are being distributed free of charge to colleges and other stations and will also be heard overseas via Armed Forces Radio.

Elvis Special In 50 Markets

LOS ANGELES—Over 50 stations have bought "The Elvis Presley Story," 12-hour, 12-chapter radio spectacular, according to Watermark, Inc., producers of the program. Playdates for the nationally syndicated special will be concentrated in October and November.

The program, produced by Ron Jacobs and adapted by Jerry Hopkins from his forthcoming Simon & Shuster biography, "Elvis," spans the singer's life from his earliest non-pro days to the present.

Stations set to air the Presley spectacular include WPIX, New York; KLAC, Los Angeles; WLW, Cincinnati; KNEW, San Francisco; KCRA, Sacramento; WCAR, Detroit; KNUZ, Houston; KXOL, Fort Worth; WNCI, Columbus, O. and KMBZ, Kansas City, Mo.; KWKH, Shreveport; WFLI, Chattanooga; KASH, Eugene, Ore.; KBFW, Bellingham, Wash. and KHYT, Tucson.



BEATS HITCHHIKING—Fantasy's Creedence Clearwater Revival hopped aboard a Lear jet recently for a flight to Hollywood where they taped an Armed Forces Network radio show with disk jockey Tom Campbell. Shown at the airport, left to right, are Stu Cook, John Fogerty, Campbell and Doug Clifford.



BEE GEES
TRAFALGAR

BEE GEES ON TOUR WITH TIN TIN

September 4 Boston, Massachusetts
 5 Asbury Park, New Jersey
 6 New York, New York
 7 New York, New York
 8 New York, New York
 9 Trenton, New Jersey
 10 Saratoga, New York
 11 Hartford, Connecticut
 12 New York, New York
 13 New York, New York
 14 New York, New York
 15 New York, New York

16 Wheeling, West Virginia
 17 Charlotte, West Virginia
 18 Knoxville, Tennessee
 19 Memphis, Tennessee
 20 Wichita, Kansas
 21 Wichita, Kansas
 22 Kansas City, Missouri
 23 Des Moines, Iowa
 24 Bloomington, Minnesota
 25 Chicago, Illinois
 26 Davenport, Iowa
 27 Davenport, Iowa

28 Indianapolis, Indiana
 29 Indianapolis, Indiana
 30 Indianapolis, Indiana
 October 1 Columbus, Ohio
 2 Evansville, Indiana
 3 St. Louis, Missouri



SD 33-7003

On Atco Records & Tapes (Tapes Distributed by Ampex)
 Sole Representation: Robert Stigwood Organisation
 67 Brook St., London, W.1., England

Additions To Radio Playlists — Primary Markets

A broad view of the titles many of radio's key Top 40 stations added to their "Playlists" last week



david cassidy
\$30.00
for 30 posters
1 free • free display

call or write **steve werner,**
v.p. marketing.

7 w 57th street, new york, ny 10019

(212) 832-0205

Gemini
 rising, inc.

WABC—NEW YORK
 A Thin Line—Persuaders—Atco
 If You Really—Stevie Wonder—Tamla
 Marianne—Steve Stills—Atlantic
 Tired Of Being—Al Greene—Hi
 Like A Yo Yo—Osmond Bros.—MGM

WLS—CHICAGO
 Chirpy chirpy—Mac & Katie—ABC
 Do You Know—Lee Michaels—A & M
 Rain Dance—Guess Who—RCA
 Theme From Shaft—Issac Hayes—Enterprise

WQAM—MIAMI
 The Night—Joan Baez—Vanguard
 Trapped By Love—Denise LaSalle—West-bound

Do You Know—Lee Michaels—A & M
 Sweet City Woman—Stampeders—Bell
 I've Found Someone—Free Movement—Decca
 Surrender—Diana Ross—Motown
 Go Away Little Girl—Donny Osmond—MGM

WKBW—BUFFALO
 Superstar—Carpenters—A & M
 It's A Crying Shame—Gayle McCormick—Dunhill
 Everyday—Weekend—Janus

WMAK—NASHVILLE
 The Story—Moody Blues—Threshold
 Ride The Bus—Brood—Dot
 Marianne—Steve Stills—Atlantic
 Roll On—New Colony 6—Sunlight
 K-Jee—Nite Liters—RCA
 Never My Love—5th Dimension—Bell
 Valarie—Cymarron—Entrance

WFIL—PHILADELPHIA
 Birds Of A Feather—Raiders—Columbia
 Chirpy Chirpy—Mac & Katie—Dunhill
 Tired Of Being—Al Greene—Hi
 Thin Line—Persuaders—Atco
 Orleans—Don Nix—Elektra

KILT—HOUSTON
 Yo Yo—Osmond Bros.—MGM
 Saturday Morning—Bobby Russel—U. A.
 If You Really—Stevie Wonder—Tamla
 Mac Arthur Park—4 Tops—Motown

WKLO—LOUISVILLE
 Like A Yo Yo—Osmond Bros.—MGM
 Bend Me, Shape Me—Storm—Sunflower
 Superstar—Carpenters—A & M
 MacArthur Park—4 Tops—Motown
 Imagine—John Lennon—Apple

KXOK—ST. LOUIS
 K-Jee—Nite Liters—RCA
 Surrender—Diana Ross—Motown
 Do You Know—Lee Michaels—A & M
 So Far Away—Carole King—Ode
 Maggie May—Rod Stewart—Mercury
 All Day Music—War—U. A.

WMEX—BOSTON
 I've Found Someone—Free Movement—Decca
 Superstar—Carpenters—A & M
 Looking Back—Bob Sieger—Capitol
 Freedom Comes—Fortunes—Capitol

THE BIG THREE

1. Yo Yo—Osmond Bros.—MGM
2. Birds Of A Feather—Raiders—Columbia
3. Never My Love—5th Dimension—Bell

WTIX—NEW ORLEANS
 Bend Me, Shape Me—Storm—Sunflower
 I Woke Up—Partridge Family—Bell
 The Night—Joan Baez—Vanguard

WDGY—MINN.
 Superstar—Carpenters—A & M
 Trapped By Love—Denise LaSalle—West-bound
 How Can I—Lynn Anderson—Columbia
 One Tin Soldier—Coven—W. B.

WEAM—WASH. D. C.
 Yo Yo—Osmond Bros.—MGM
 Do You Know—Lee Michaels—A & M

CKLW—DETROIT
 Thin Line—Persuaders—Atco
 Do I Love You—Paul Anka—Buddah
 It's For You—Springwell
 Surrender—Diana Ross—Motown
 Theme From Shaft—Issac Hayes—Enterprise
 Imagine—John Lennon—Apple

WOKY—MILWAUKEE
 Yo Yo—Osmond Bros.—MGM
 Road Runner—Tax Deductable
 Handbags & Gladrags—Chase—Epic

WIXY—CLEVELAND
 If You Really—Stevie Wonder—Tamla
 Yo Yo—Osmond Bros.—MGM
 I've Found Someone—Free Movement—Decca
 One Fine Morning—Lighthouse—Evolution
 Charity Ball—Fanny—Reprise
 The Night—Joan Baez—Vanguard

WSAI—CINCINNATI
 Yo Yo—Osmond Bros.—MGM
 Womens Love Rights—Laura Lee—Hot Wax
 If You Really—Stevie Wonder—Tamla

WMPS—MEMPHIS
 Never My Love—5th Dimension—Bell

KHJ—HOLLYWOOD
 Peace Train—Cat Stevens—A & M
 Never My Love—5th Dimension—Bell
 If You Really—Stevie Wonder—Tamla

KFRC—SAN FRANCISCO
 Wedding Song—Paul Stookey—W. B.
 I'm Coming Home—Tommy James—Roulette
 That's The Way—Messengers—Rare Earth
 Trapped By Love—Denise LaSalle—West-bound
 K-Jee—Nite Liters—RCA

KGB—SAN DIEGO
 Superstar—Carpenters—A & M
 Roll On—New Colony 6—Sunlight
 Yo Yo—Osmond Bros.—MGM

KYA—SAN FRANCISCO
 Call My Name—Wilson Pickett—Atlantic
 Breakdown—Rufus Thomas—Stax
 Yo Yo—Osmond Bros.—MGM
 So Far Away—Carole King—Ode
 If You Really—Stevie Wonder—Tamla

KYNO—FRESNO
 I'm Coming Home—Tommy James—Roulette
 Where Evil Grows—Poppy Family—London
 Mac Arthur Park—4 Tops—Motown

KNDE—SACRAMENTO
 Wedding Song—Paul Stookey—W. B.
 Birds Of Feather—Raiders—Columbia
 Everthings Allright—Yvonne Elliman—Decca
 Never My Love—5th Dimension—Bell
 Imagine—John Lennon—Apple

WRKO—BOSTON
 Tired Of Being—Al Greene—Hi
 Saturday Morning—Bobby Russel—U. A.
 Yo Yo—Osmond Bros.—MGM
 Imagine—John Lennon—Apple
 All Day Music—War—U. A.
 Your Move—Yes—Atlantic
 One Fine Morning—Lighthouse—Evolution

WKNR—DETROIT
 It's For You—Springwell—Parrot
 I Woke Up—Partridge Family—Bell
 Yo Yo—Osmond Bros.—MGM
 Thin Line—Persuaders—Atco
 Is That The Way—Tin Tin—Atco
 Charity Ball—Fanny—Reprise
 Gypsies, Tramps & Thieves—Cher—Kapp
 Some Of Shellys—Nitty Gritty—U. A.

WIBG—PHILADELPHIA
 Another Time—Engelbert Humperdinck—Parrot
 Crazy Love—Helen Reddy—Capitol
 It's A Crying—Gayle McCormick—Dunhill
 Question 67—Chicago—Columbia
 Song For You—J. P. Morgan—Beverly Hills

KQV—PITTSBURGH
 Yo Yo—Osmond Bros.—MGM
 Stop Look—Stylistics—Avco
 Chirpy Chirpy—Mac & Katie—ABC

WAYS—CHARLOTTE
 Trapped By Love—Denise LaSalle—West-bound
 Bend Me, Shape Me—Storm—Sunflower
 Wedding Song—Paul Stookey—W. B.
 Never My Love—5th Dimension—Bell
 I'm Coming Home—Tommy James—Roulette
 I've Found Someone—Free Movement—Decca
 Don't Try—John Baldry—W. B.
 The Story—Moody Blues—Threshold
 Orleans—Don Nix—Elektra

KLIF—DALLAS
 Easy Loving—Freddie Hart—Capitol
 New Jersey—England Dan—A & M
 Rub It In—Layne Martine—Barnaby
 Wedding Song—Paul Stookey—W. B.
 Birds Of Feather—Raiders—Columbia
 Think His Name—Johnny Rivers—U. A.
 A Hard Rain—Leon Russel—Shelter
 Solo—Billie Sands—Invictus
 Call My Name—Wilson Pickett—Atlantic

WAPE—JACKSONVILLE
 Chirpy Chirpy—Mac & Katie—ABC
 Superstar—Carpenters—A & M
 Mac Arthur Park—4 Tops—Motown
 Maggie May—Rod Stewart—Mercury
 Smack Water Jack—Carole King—Ode
 I'm Coming Home—Tommy James—Roulette
 Bend Me—Storm—Sunflower

WHB—KANSAS CITY
 Birds Of Feather—Raiders—Columbia
 Maggie May—Rod Stewart—Mercury
 So Far Away—Carole King—Ode
 Never My Love—5th Dimension—Bell

KILT—HOUSTON
 Birds Of Feather—Raiders—Columbia
 Yo Yo—Osmond Bros.—MGM
 If You Really—Stevie Wonder—Tamla
 Saturday Morning—Bobby Russel—U. A.

WCAO—BALTIMORE
 Sweet City Woman—Stampeders—Bell
 Love We Had—Dells—Cadet
 Another Time—Engelbert Humperdinck—Parrot
 Wedding Song—Paul Stookey—W. B.
 Birds Of Feather—Raiders—Columbia
 Gypsies, Tramps & Thieves—Cher—Kapp
 I'm Coming Home—Tommy James—Roulette

The Lowery Group
SENSATIONAL SUMMER OF '71

Hot off the "Indian Reservation", THE RAIDERS follow their million seller with JOE SOUTH'S "BIRDS OF A FEATHER"
Thanks, The Lowery Group

Freddie North
"She's All I've Got"

Charted in Billboard, Cashbox, Record World

Mankind 12004

A Jerry Williams Production

Distributed by Nashboro Records, 1011 Woodland St., Nashville, Tennessee

FROM HIS HIT LP*
A NEW HOT SINGLE!

TOMMY JAMES

SINGS

"I'M COMIN' HOME"

R 7110



Produced by Tommy James & Bob King
For Tommy James Ventures Inc.
Arranged & Conducted by Jimmy "Wiz" Wisner

*Which includes his recent over 1,000,000
seller "Draggin' the Line."



Roulette Records Inc.
17 W. 60th Street
New York, New York

Additions To Radio Playlists Secondary Markets

A broad view of the titles many of radio's key Top 40 stations added to their "Playlists" last week.

WDRG—HARTFORD
Wedding Song—Paul Stookey—W.B.
Like A Yo Yo—Osmond Bros.—MGM
Rain Dance—Guess Who—RCA
Chirpy Chirpy—Mac & Katie—ABC

WLAV—GRAND RAPIDS
One Fine Morning—Lighthouse—Evolution
Solo—Billy Sands
Take Me Girl—Jr. Walker—Soul
Tired Of Being—Al Greene—Hi
Is That The Way—Tin Tin—Atco
Where Evil Grows—Poppy Family—London

WBAM—MONTGOMERY
Get It While—Janis Joplin—Columbia
Like A Yo Yo—Osmond Bros.—MGM
I'm Coming Home—Tommy James—Roulette

WGII—BABYLON
Like A Yo Yo—Osmond Bros.—MGM
Make It Funky—James Brown—Polydor
One Fine Morning—Lighthouse—Evolution
Birds Of A Feather—Raiders—Columbia
California Kid—Lobo—Big Tree
Gimme Shelter—Grand Funk—Capitol
Imagine—John Lennon—Apple

WJET—ERIE
Roll On—New Colony 6—Sunflower
Do You Know—Lee Michaels—A & M
Wedding Song—Paul Stookey—W.B.
Yo Yo—Osmond Bros.—MGM
Birds Of A Feather—Raiders—Columbia
Do All My Crying—Sounds Of Sunshine—
Ranwood
I Like To—Peoples Choice—Phil. L.A. Of
Soul

WIRL—PEORIA
Annabella—Hamilton, Joe Frank—Dunhill
Birds Of A Feather—Raiders—Columbia
Some Of Shellys—Nitty Gritty—U.A.
How Can I—Lynn Anderson—Columbia
Is That The Way—Tin Tin—Atco
Colour My World—Chicago—Columbia
I Woke Up—Partridge Family—Bell
Maggie May—Rod Stewart—Mercury

WLOF—ORLANDO
I've Found Someone—Free Movement—Decca
Wedding Song—Paul Stookey—W.B.
Don't Try—John Baldry—W.B.
I'm Coming Home—Tommy James—Roulette
Bend Me—Storm—Sunflower
One Fine Morning—Lighthouse—Evolution

WSGN—BIRMINGHAM
Yo Yo—Osmond Bros.—MGM
Roll On—New Colony 6—Sunlight
If You Really—Stevie Wonder—Tamla
Wedding Song—Paul Stookey—W.B.

WKWK—WHEELING
It's For You—Springwell—Parrot
Them Changes—Buddy Miles—MGM
Natural Man—Lou Rawls—MGM
One Fine Morning—Lighthouse—Evolution
Rub It In—Lanyun Martine—Barnaby
He'd Rather—Heavenbound—MGM

WCRB—WASHINGTON N.J.
I'm Coming Home—Tommy James—Roulette
Yo Yo—Osmond Bros.—MGM
Never My Love—5th Dimension—Bell
Trapped By Love—Denise LaSalle—West-
bound
It's A Crying—Gayle McCormick—Dunhill

KLEO—WICHITA
Stick Up—Honey Cone—Hot Wax
Sweet City Woman—Stampede—Bell
Handbags & Gladrags—Chase—Epic

WCOL—COLUMBUS
Loving Her Was Easier—Kris Kristofferson—
Monument
Roll On—New Colony 6—Sunflower
Stagger Lee—Tommy Roe—ABC
Can't Give Back—Vikki Carr—Columbia

WBBQ—AUGUSTA
Never My Love—5th Dimension—Bell
Midnight—James Gang—ABC
That's The Way—Messengers—Rare Earth
Birds Of A Feather—Raiders—Columbia
Gypsies Tramps & Thieves—Cher—Kapp
I'm An Easy Rider—My Friend

WLEE—RICHMOND
Superstar—Carpenters—A & M
I Woke Up—Partridge Family—Bell
Won't Get Fooled—Who—Decca
Saturday Morning—Bobby Russel—U.A.

KIOA—DES MOINES
Charity Ball—Fanny—Reprise
Maggie May—Rod Stewart—Mercury
What You See—Dramatics—Volt
Sweet City Woman—Stampede—Bell

WTRY—ALB., SCH., TROY
Birds Of Feather—Raiders—Columbia
Mac Arthur Park—4 Tops—Motown
Yo Yo—Osmond Bros.—MGM

WHLO—AKRON
Yo Yo—Osmond Bros.—MGM
Never My Love—5th Dimension—Bell
Thin Line—Persuaders—Atco
One Fine Morning—Lighthouse—Evolution
California Kid—Lobo—Big Tree

WPRO—PROVIDENCE
Superstar—Carpenters—A & M
Stagger Lee—Tommy Roe—ABC
Loving Her Was Easier—Kris Kristofferson—
Monument
Birds Of Feather—Raiders—Columbia
Crazy Love—Helen Reddy—Capitol

WING—DAYTON
K-Jee—Nite Liters—RCA
Superstar—Carpenters—A & M
Tired Of Being—Al Greene—Hi
Marianne—Steve Stills—Atlantic
Wedding Song—Paul Stookey—W. B.
Never My Love—5th Dimension—Bell
Mammy Blue—Pop Tops

WPOP—HARTFORD
Yo Yo—Osmond Bros.—MGM
Surrender—Diana Ross—Motown
Loving Her Was Easier—Kris Kristofferson—
Monument
Freedom Comes—Fortunes—Capitol
It's A Crying—Gayle McCormick—Dunhill
All My Trials—Ray Stevens—Barnaby

WAVZ—NEW HAVEN
Is That The Way—Tin Tin—Atco
Gimme Shelter—Grand Funk—Capitol
Military Madness—Graham Nash—Atlantic
One Fine Morning—Lighthouse—Evolution
Koko Joe—Jerry Reed—RCA
Roll On—New Colony 6—Sunlight
Never My Love—5th Dimension—Bell
Yo Yo—Osmond Bros.—MGM
Don't Try—John Baldry—W. B.
Everything Alright—Yvonne Elliman—Decca

tape news report

Japan Firms Bow Hi-Pack Configuration; Look to Compete with Cassette/8-Track

TOKYO — Five prominent Japanese music/electronic firms issued a joint announcement at a meeting here in the Tokyo Hilton (Aug. 20) to announce the official introduction of the Hi-Pack stereo tape configuration to the world music market. The Hi-Pack, the first tape configuration to be originated in Japan, is described by Toshiba Musical Industry president Suga as: "... a third kind of tape in a continuous loop offering light weight, compactness, good sound quality and a wide range of applications. Hi-Pack originated from the idea that cartridge tapes could be made even smaller and with a simpler mechanism. It is one quarter the size of an 8-track tape and

has one half its speed, with the same recording capacity."

At present, according to Suga, there are ten manufacturing companies involved in the Hi-Pack configuration; three in software, six in hardware and one in both software and hardware, and they have already begun marketing products.

"I hope that this, the first tape born in Japan, will spread throughout the world," Suga declared.

The five affiliated companies making up the Hi-Pack Committee are Apollon Musical Industry, Toshiba Musical Industry, Nippon Columbia, Pioneer and Mitsui Electric Company. Suga revealed that Pioneer and Mitsui Electric have started selling hardware products while Toshiba, Columbia and Apollon have started selling software. Hitachi, Toshiba Electric, Columbia and Apollon also plan to market hardware soon, while a large number of manufacturers plan to collaborate in marketing software products.

Young To Head AST Distrib Relations

NEW YORK — Peter Young has been named distributor relations manager of Ampex Stereo Tapes, according to Harvey Urman, A.S.T. national sales manager.

Young is in charge of AST's independent accounts and the company's sales managers report to him, under the appointment. He was formerly assistant product manager based in Los Angeles. He joined Ampex three years ago as a tape specialist and was named Western regional sales manager in September 1969.

Veri/Sonics Formed For Premium Field

LOS ANGELES — Warren Gray, former executive V.P. of Audio-Video Communications, has formed Veri/Sonics Inc., a music-tape production company which will package records, cassettes and cartridges for sale to the premium field. The firm, according to Gray, already boasts a library of about 10,000 recordings.

Gray has opened offices in Hollywood and New York with distribution-warehousing in those two locations and in Chicago. He will headquarter in Hollywood with Sue Kayser, sales administration director.

"Veri/Sonics will sign artists and create masters for the premium field and work with recording artists of other labels in conjunction with premium packages," Gray stated.

The company will be represented at the Premium Show in Chicago, Sept. 13-16, where Gray will select representatives in the premium market for his company.

New Products



The Duotone Co., manufacturers of phonograph needles and other record supplies and accessories, has introduced its TW-35 merchandising display rack, carrying a wide assortment of tape accessories, for the retail market.

The assortment of accessories includes splicing tape strips, tape recorder head lubricant, end clips, head cleaners, identification labels, log discs and other instruments and accessories. Items are available in quantities of five.

The TW-35 (shown above) comes complete with the free wire rack. Quoted price for the complete package is \$35.00 with immediate delivery promised.

GRT Promo Winners



Little Rock, Ark. — Grand prize winners of GRT Music Tape's "Steakout City" promotion were awarded vouchers for a prime filet steak dinner for two in the restaurant of their choice anywhere in the U.S. Top awards, which were for GRT tape distributor salesmen and dealers, went to salesman William (Butch) Fisher III (second from left) of Bill Fisher Auto Air Conditioning, Inc., who will have his dinner in Las Vegas, and dealer Harold Hudson (second from right), owner of Hudson Outboard Sales and Service, who'll dine in San Francisco. Presenting the awards is GRT district salesman John Craft (right), while William (Bill) Fisher (left), owner of Bill Fisher Auto Air Conditioning looks on proudly as his son receives his prize. Dealers and GRT distributor salesmen also won 120 lesser awards.

EVR Chief At VPA

NEW YORK — At the September 13th meeting of the Videotape Production Association, Robert Brockway, President of the CBS EVR Division, will discuss color capabilities of the video cassette by demonstrating the Apollo 15 cassette, the first EVR color cassette made from color TV.

The meeting, to be held at the Ad Club, 23 Park Avenue at 6:15 P.M., will also feature TeleVideo Director Larry Goldwasser. It will be an open meeting.

The Lowery Group
**SENSATIONAL
SUMMER
OF '71**
 "ALL MY HARD
TIMES"
 JOE SIMON
 sings it
 with a taste of soul
 on Spring Records
 (distributed by Polydor).

1650 BROADWAY

Corner 51st Street

"Best known address in the entertainment field"

24 hour service

"Attractive Offices and Suites, centrally air conditioned,
individually controlled, available now or shortly."

The DILLIARD Corp.

Miss E. Kunzman • Plaza 7-4400



FORCED FROM THEIR LP !!



THE FUZZ

"I'M SO GLAD"

Calla 179

Be sure to stock up on their exciting new LP, THE FUZZ which also includes their two previous hits "I LOVE YOU FOR ALL SEASONS" and "LIKE AN OPEN DOOR".

Produced by Joe Tate
for Carr-Cee Productions Inc.



On Calla Records
Distributed Exclusively by Roulette
17 West 60th Street New York, N.Y.



cashbox/singles reviews

Picks of the Week

THE JAMES GANG (ABC 11312)

Midnight Man (2:40) (Pamco/Home Made Music, BMI—J. Walsh)

Delivering their most commercial outing to date, single culled from the Gang's "Thirds" album, with its Beatle-ish similarities is likely to provide their first top twenty smash. A brilliant release from three of America's finest musicians. Flip: no info. available.

THE FORTUNES (Capitol 3179)

Freedom Comes, Freedom Goes (3:18) (Maribus Music, BMI—Cook, Greenaway, Hammond, Hazelwood)

Coming off a number one record, the Fortunes, now with the accent on the calypso sound, are in store for monster receptions in all AM teen markets. Should reach the top ten status in a matter of weeks. Flip: no info. available.

TOMMY JAMES (Roulette 7110)

I'm Comin' Home (2:03) (Big Seven Music, BMI—James-King)

Somewhat of a disappointment after his perfect "Draggin' The Line" venture, James' follow up seems to lack the magic and hypnotic qualities of his previous single but will receive instant AM airplay and teen exposure certain to make this effort another chart success. Flip: no info. available.

CYMARRON (Entrance 7502)

Valerie (1:58) (Press Music, BMI—R. Mainegra)

Group's follow up to their "Rings" smash is equally commercial and is likely to carry group into top 10 category. Single was issued from Cymarron's newly released LP. Flip: "Across The Kansas Sky" (2:50) (Press Music, BMI—S. Parks)

THE ISLEY BROTHERS (T-NECK 932)

Spill The Wine (2:46) (Far Out Music, ASCAP—Miller, Scott, Dickerson, Jordan, Brown, Allen, Oscar)

Culled from their latest album, "Givin It Back," the Isley's, fresh off a top ten single, are headed right back up to the top with their exceptional remake of the War hit. Rapid sales recognition and instant airplay are a certainty. Flip: no info. available.

DAVE & ANSELL COLLINS (Big Tree 125)

Monkey Spanner (2:43) (Interglobal Music, ASCAP—Riley, Collins)

The dynamic "Double Barrel" duo return with another outing in the same musical vein, but with a bit more vocalizing this time around. Having already had much success in England, single is likely to repeat in this country. Record will take off in all teen markets because of its obvious commercial appeal. Flip: no info. available.

THE FUZZ (Calla 179)

I'm So Glad (2:41) (Jamf/Ferndcliff/Sharleff Music, BMI—Tate Young)

Not to be confused with the Cream classic, groups latest is a bouncy appealing number certain to further establish them as consistent chart contenders. Airplay guaranteed based on their prior success. Flip: no info. available.

TEN YEARS AFTER (Columbia 45457)

I'd Love To Change The World (3:11) (Chrysa-A Lee Music, BMI—A. Lee)

Alvin Lee offers a bit of philosophical advice on changing the world via this first Columbia single from TYA. Unlike their previous jazz/blues outings, fine acoustic guitaristry highlights a potential top 40 seller. Flip: no info. available.

YVONNE ELLMAN (Decca 32870)

Everything's Alright (3:05) (Leeds Music, AS—Rice, Webber)

Yvonne once again reaches into the wealth of material from the Rice-Webber classic and comes up with a winner every bit as strong as her first "I Don't Know How To Love Him" disk. Record is guaranteed much MOR exposure and a good chance of gaining rapid chart fame. Flip: no info. available.

Newcomer Picks

TERESA (SSS 850)

He's A Cooker (2:54) (Green Isle/Fred Burch Music, BMI—Burch-Young)

Already a regional breakout record, debut performance from Teresa will soon surge onto national charts. Single explodes musically and vocally and will find favor with the dance crowds. Excellent choice for all AM top 40 programmers. Flip: no info. available.

DOCTOR MUSIC (Bell 45-132)

One More Mountain To Climb (3:14) (Kirshner/ATV Music, BMI—Sedaka, Greenfield)

Doctor Music's prescription for a hit record was written by Neil Sedaka and Howard Greenfield, and offers a dynamic chorus certain to find favor with pop formats. Single should catch on immediately and spread to national attention. Flip: "The Land" (2:58) (Dr. Music, ASCAP—Russell, Desmond)

Choice Programming

Choice Programming selections are singles which, in the opinion of our reviewing staff, are deserving of special programmer consideration.

VILLAGE SOUL CHOIR (Abbott 2028)

The Sissy Football (Part 1) (2:54) (Chevellyn Music, BMI—Sir Charles Matthews) Powerfully funky outing should entice all r&b locations and dance freaks alike. Single creates much musical excitement and could explode into a chart contender. Flip: Part 2 (2:48) (same credits)

PERCY SLEDGE (Atlantic 2826)

That's The Way I Want To Live My Life (2:45) (Muscle Shoals, BMI—Mitchell) Driving ballad should kindle a scorching r&b flame across the country. Sledge's performance is first rate, as usual, and this one could break big. Flip: "Stop The World Tonight" (3:10) (Combine, BMI—Seals)

THE LORDS (Mikem 1501)

Since I Fell For You (3:30) (Warner Bros Music, ASCAP—Johnson) Funky, syncopated remake of the great Lenny Welch classic will guarantee the Lords instant airplay and a shot at chart fame. Flip: no info. available.

JOHN HETHERINGTON (Uni 55301)

Home (2:50) (Gil Music, BMI—Hetherington) Soft, acoustic ballad compassionately performed by newcomer Hetherington is likely to find a place amongst all good music lovers. Flip: "Hello" (2:45) (same credits)

TUCKY BUZZARD (Capitol 3171)

Time Will Be Your Doctor (2:58) (Buzz Music, ASCAP—T. Buzzard) From their first album produced by the Stones Bill Wyman comes this powerful rocker displaying both fine musicianship and expert vocal harmony. Side is already receiving much underground airplay. Flip: "Pices Apple Lady" (2:46) (Skyhill Music, BMI—L. Russell)

MERRILEE RUSH (Scepter 12329)

Child Of Mine (3:42) (Screen Gems/Columbia, BMI—Goffin, King) Attracted by Goffin/King material, Merrilee Rush is creating quite a sensation via heavy airplay and sales receptions. This latest outing should put Merrilee merrily on the charts. Flip: no info. available.

AIRTO (Buddah 244)

Andie (I Walked) (2:40) (Kama Sutra/LLza Music, BMI—H. Pascoal) Strange, enticing chant should stir all kinds of interest from both AM and underground programmers. Record could turn into a juke box giant. Flip: "Papo Furads" (3:29) (same credits)

GIL SCOTT HERON (Flying Dutchman 26011)

The Revolution Will Not Be Televised (3:07) (Thiele Music, ASCAP—Heron) Funky narrative with contemporary message much in same musical direction as the Last Poets, could explode sales wise and become one of the most frequently played singles. A natural for all FM and underground markets. Flip: "Home Is Where The Hatred Is" (3:22) (same credits)

DON NIX (Elektra 45746)

Olena (3:20) (Deerwood, BMI—Nix) Good o'd fashioned rock 'n roll number with driving rhythms should spark mighty sales reactions for Nix in his bid for a hit record. Shortened version culled from his album will get much AM and FM airplay. Flip: "Riding The B'inds" (2:45) (same credits)

SHIRL MILETE (Poppy 0107)

She'd Better Be (2:31) (Norma/SPR Music, BMI—Rabbitt, Silverstein) Powerful vocal performance with country overtones is likely to spark both pop and country listener reaction for husky voiced Milete. Fine outing from artist who should be around for many years. Flip: "I Cry My Heart Out Over You" (2:46) (Hill & Range/Last Straw Music, BMI—Milete)

TJMMIE ROGERS (Cadet 5685)

Super Soul Brothers (3:52) (Crazy Music, ASCAP—T. Rogers) History of soul music in narrative form with funky musical accompaniment should start many a turn table spinning with delight. Rogers mighty performance carries with it built in teen action. Flip: "It Rolls Thru Everything" (2:18) (Crazy Music, ASCAP—Rogers, Fields)

TEEGARDEN AND VAN WINKLE (Westbound 187)

Stoned On The Love For Jesus (2:44) (Bridgeport Music, BMI—Knappe, Teggarden) Funky sing a long tune will put duo right back on the hitbound path as selection is every bit reminiscent of their top tenner "God Love And Rock 'n Roll." Flip: "I Need You" (2:52) (same credits)

JERRY BUTLER (Mercury 73241)

Walk Easy My Son (2:55) (Butler Music, ASCAP—C. Jackson) Strong rhythm and blues number with plenty of commercial appeal and cross over possibilities will put Butler right back on the charts. Flip: "Let Me Be" (3:00) (Alexscar Music, BMI—S. Scarborough)

DON ELLIS (Columbia 45446)

Tears Of Joy (2:55) (Objective Music, BMI—Ellis) The master of time signatures, Don Ellis, tears into this instrumental gracefully adding to it much commercial value. Record should be getting much AM/MOR airplay. Flip: no info. available.

BETTY EVERETT (Fantasy 667)

I'm A Woman (2:47) (BEK, BMI—King) Powerfully performed tune with much rhythm and blues appeal could serve to break wide open as an across the boards hit. Fine production and arrangement aid to record's depth and AM appeal. Flip: no info. available.

BURT BACHARACH (A&M 1290)

One Less Bell To Answer (3:08) (Blue Seas/Jac Music, ASCAP—Bacharach—David) Originally written by Bacharach and David for the 5th Dimension who have turned the song into a classic, latest remake, by the actual authors should revive interest from both MOR and top 40 markets. Single was culled from Burt's latest album. Flip: "Freefall" (3:04) (Hidden Valley Music, ASCAP—Bacharach)

JO MEEK (United Artists 50838)

You'd Better Believe It (2:40) (UA Music, ASCAP—Paxton—Welch) New female find delivers a mighty commercial punch with her first single outing. Co written by Tom Paxton, tune could put Jo in national spotlight. Flip: "Too Good To Be True" (2:10) (same credits)

MARK PALMER (Spark 02)

Take A Little Time Out Girl (3:15) (Southern Music, ASCAP—T. McKeon) Stunning debut for Palmer marks him as a potential hitmaker of the future. Tightly written number focuses on Palmer's strong vocal presentation certain to please AM programmers. Flip: no info. available.

GET STONED ON THE LOVE FOR JESUS (WHILE IT'S STILL LEGAL.)

Teegarden and VanWinkle, whose last single spread the word about God, Love and Rock and Roll, continue upward with a new single which reveals that getting stoned doesn't always depend on what you put in your pipe.



Stoned On The Love For Jesus/Teegarden And VanWinkle (W-187)

A new single on Westbound Records.



Vital Statistics

#57*
Yo-Yo (2:50)
Osmond Bros.—MGM K-14295
2165 Sunset Blvd. L. A., Cal.
PROD: Rick Hall c/o MGM
PU8: Lowery Music 8MI
Box 9687, Atlanta, Ga.
WRITER: Joe South
ARR: Harrison Calloway, Jr.
FLIP: Keep On My Side

#82*
One Fine Morning (2:54)
Lighthouse—Evolution 1048
118 West 57th St, NYC 10019
PROD: Jimmy Ienner
370 Lexington Ave., NYC
PU8: C.A.M. USA, Inc. BMI
370 Lexington Ave., NYC
WRITER: Skip Prokop
ARR: Prokop & Jolimore
FLIP: Little Kind Words

#84*
That's the Way a Woman Is (1:54)
Messengers—Rare Earth 5032
c/o Motown, 2457 Woodward, Detroit
PROD: Mass Productions c/o Motown
PUB: Stein & Van Stock/Positive ASCAP
c/o Motown
WRITERS: Morgan & Moier
FLIP: In the Jungle

#86*
Stone of Years (2:44)
Emerson, Lake & Palmer
Cotillion 44131
1841 8'way, NYC
PROD: Greg Lake for E.G. Records
c/o Cotillion
PU8: TRO-Total Music 8MI
10 Columbus Circle, NYC
WRITERS: Emerson & Lake
ARR: Emerson, Lake & Palmer
FLIP: Time and a Place

#87*
Handbags & Gladbags (3:18)
Chase—Epic 10775
51 W. 52nd St., NYC
PROD: Frank Rand & Bob DeStocki
Lee Pdtns, 180 N. Michigan, Chicago
PU8: Lovely Music Inc., ASCAP
WRITER: Mike D'Abo
ARR: Ware & O'Rourke
FLIP: Open Up Wide

#88*
One Tin Soldier (3:18)
Coven—Warner Bros. 7509
4000 Warner Blvd. Burbank, Cal.
PROD: Mundell Lowe c/o W8
PU8: Cents & Pence Music 8MI
c/o Taylor, Laughlin Ent. Corp.,
1900 Ave. of the Stars, Century City, Cal.
WRITERS: Dennis Lambert & Brian Potter
FLIP: I Think You Always Knew

#92
California Kid & Reemo (2:44)
Lobo—Big Tree 119
c/o Ampex, 555 Madison, NYC
PROD: Phil Gernhard
6727 First Ave. S., St. Petersburg, Fla.
PU8: Ensign Music 8MI
1 Gulf-Western Plaza, NYC 10023
WRITERS: M. Gatley & R. John
FLIP: A Little Different

#97
Hi Jackin' Love (2:53)
Johnny Taylor—Stax 0096
926 E. McLemore St. Memphis, Tenn.
PROD: Don Davis
926 E. McLemore, Memphis
PUB: Groovesville 8MI
221 W. 57th St., NYC
WRITERS: T. Hester, R. Wylie
FLIP: Love In the Streets

#98
You've Got to Crawl (2:40)
8th Day—Invictus 9098
3125 Cadillac Towers, Detroit
PROD: Greg Perry for Holland Dozier & Holland
WRITERS: Bond, Perry, Johnson, Dunbar
FLIP: It's Instrumental to be Free

#99
All My Hard Times (2:46)
Joe Simon—Spring 118
Dist. by Polydor, 1700 8'way, NYC
PROD: John Richbourg
PU8: Lowery Music 8MI
Box 9687 Atlanta, Ga.
WRITER: Joe South
FLIP: Georgia Blue

#100
The Year that Clayton Delaney Died (2:44)
Tom T. Hall—Mercury 73221
35 E. Wacker Drive, Chicago, Ill.
PROD: Jerry Kennedy
1521 Hawkins St., Nashville, Tenn.
PUB: Newkeys Music Inc. BMI
1531 Demonbreun St., Nashville
WRITER: Tom T. Hall
FLIP: Second Hand Flowers

Looking Ahead

- BEND ME, SHAPE ME**
(Helios—BMI)
Storm—Sunflower 113
- CALIFORNIA ON MY MIND**
(J. W. T.—ASCAP)
Morning Mist—Event 206
- AMANDA**
(Screen Gems/Columbia—BMI)
Dionne Warwick—Scepter 12326
- I KNOW I'M IN LOVE**
(Kama Sutra, James Boy—BMI)
Chee Chee & Peppy—Buddah 225
- THEM CHANGES**
(Miles Ahead/Three Bridges—ASCAP)
Buddy Miles—Mercury 73228
- YOU SEND ME**
(Higvero—BMI)
Ponderosa Twins-Plus One—Horescope 102
- KEEP ME**
(Jobete—BMI)
Originals—Soul 35085
- GOT TO GET OVER THE HUMP**
(Cachand/Tecbob—BMI)
Simtek & Wiley—M. Chand 8005
- CHARITY BALL**
(Brain Tree, Tinkle Tunes—BMI)
Fanny—Reprise 1033
- A SONG FOR YOU**
(Skyhill Music—BMI)
J. P. Morgan—Beverly Hills 9367
- ZOO DE ZOO SONG**
(Maribus—BMI)
Twiggy & Friends—Bell 115

- DAY BY DAY**
(Valando, Cadenza—BMI)
Holly Sherwood—Carouse 1038
- LORD HAVE MERCY**
(Marlu-Far Fetched—ASCAP)
Black Oak Arkansas—Atco 6829
- TAKE YOU WHERE THE MUSIC'S PLAYING**
(Trio—BMI)
Dallas—Marina 501
- SOME OF SHELLY'S BLUES**
(Screen Gems, Col.—BMI)
Nitty Gritty Dirt Band—U.A. 50817
- IT'S FOR YOU**
(MacGlen—BMI)
Springwell-Parrot 359
- I LIKE WHAT YOU GIVE**
(Lizard—ASCAP)
Nolan—Lizard 1008
- THE SONG IS LOVE**
(Pepamar—ASCAP)
Mary Travers—Warner Bros. 7517
- A LONG TIME, A LONG WAY TO GO**
(Earmark, Screen Gems—BMI)
Runt—Bearsville 31004
- SMACKWATER JACK**
(Screen Gems/Col.—BMI)
Carole King—ODE 66019

MAM Label Steps Up U.S. Activity

NEW YORK — There's stepped up action at MAM Records, according to Walt Maguire, vice president for pop A & R at London Records, national distributor for MAM. The English-based company is a part of the giant MAM talent agency complex in London, headed by Gordon Mills, who is personal manager of both Tom Jones and Engelbert Humperdinck.

MAM, which first came to prominence in this country with the Dave Edmunds smash earlier this year of "I Hear You Knockin'," a long ago hit for Fats Domino, recently issued another Edmunds reprise of a Domino hit, "Blue Monday." This disk is

already showing up on national charts.

Gordon Mills is the producer of the latest production to feature Gilbert O'Sullivan, who, like Jones and Humperdinck, is also a Mills discovery. "Gilbert O'Sullivan Himself" is the singer's new LP, to hit the market in Sept. His latest single, "We Will," is just not hitting the market. It is now in the top 20 in England.

Australian singer Frank Ifield, who scored an international hit with "I Remember You" a decade ago, returns to the chart wars with another country-styled single, "Lonesome Jubilee." On this disk, Ifield was reunited with his EMI producer Norrie Paramour.

Two other acts are also making their debuts on MAM. These include Fuzzy Duck, a new progressive rock-oriented group, and 17-year-old cabaret singer, Teena Charles. Her first single, produced by Mills, is "Baby Don't You Know."

Another new group, Demick-Armstrong, has a new single, "Little Willie Ramble." This blues-based group consists of Rod Demick and Herbie Armstrong, with heavy rock back-up and a big band background spotlighting massed trombones.

Taylor Gold On 'Friend'

NEW YORK — James Taylor's "You've Got a Friend" single has been certified by the RIAA as a gold record.

"Friend" comes from Taylor's second Warner Bros. album, "Mud Slide Slim and The Blue Horizon," which was recently certified as a gold album. Taylor also received a gold record for his debut Warner Bros. album "Sweet Baby James," giving the top-selling singer-guitarist-composer three gold record awards.

Taylor will be appearing on Sept. 10, 11 and 12 at Carnegie Hall in New York, for three concerts that sold out the first day tickets went on sale. Taylor then goes to California for a Sept. 18 date in the Hollywood Bowl.

Goldie Hawn To Reprise

NEW YORK — Goldie Hawn, comedienne and film actress with an Academy Award (Best Supporting Actress in "Cactus Flower"), has been signed to an exclusive recording contract by Reprise Records. The deal was negotiated for Miss Hawn by her manager Art Simon.

Her first album, scheduled for release early next year, will be produced by Warner/Reprise staffers Lenny Waronker and Andy Wickham. Miss Hawn's only singing exposure to date was on her Feb. 15, 1971 television special, "Pure Goldie," although her musical experience extends back to her 1966-67 days as a Las Vegas chorus girl. After two years as the wide-eyed wonder of NBC's "Laugh-In," Miss Hawn made three films: "Cactus Flower," "There's A Girl In My Soup," and the upcoming "Dollars." She begins work on "Butterflies Are Free" this fall.

Savoy To Chips

PHILADELPHIA — Chips Distributing, this city, has acquired the Savoy label's jazz and gospel lines in this area.

Polydor Signs Eyrie

NEW YORK — Polydor Incorporated has signed Eyrie, a five-man rock group to a long-term contract. The deal was made by Jerry Schoenbaum, president of Polydor, with AZA Productions, which is owned by Ron Terry, who is also manager and producer of the group.

The group's first album will be issued shortly. The group members are John DeMartino on flute, piccolo and saxophone; his brother Ralph on lead guitar; Michael Rodriguez, bass; Dennis Carvone, keyboards and vocals; and Robert Steuhler on drums. All the songs were written by Terry and Ralph DeMartino.

Atlantic Buys Houston Master

NEW YORK — Atlantic vp Jerry Greenberg reports that the company had picked up a h master formerly on the Mod International label called "Used To Be" by Just Us. The record is now on Atlantic.

The record is reported to have broken wide open initially in the Houston area, spurred by early play on radio station KILT, and has now spread to other major markets. Atlantic has set up a strong promo campaign and has its network of promo men blanketing the country with the disk.

Deal was negotiated between Greenbert and Jim D. Johnson of ABALL Productions.

**FACE IT.
SHE'S TALKING ABOUT YOU!**

**BLACK IVORY
WANDA
ROBINSON**

BLACK IVORY
WANDA ROBINSON

OVER 20,000 SOLD IN ONE WEEK IN NEW YORK,
BALTIMORE-WASHINGTON, PHILADELPHIA,
DETROIT AND CHICAGO.

HAVE YOU STOCKED "WANDA ROBINSON"
(PLP-18)?



perception records inc. today records inc., dwarf records
red bullet records are distributed throughout the u.s.a.
canado by ampex corp. distributed on records in con
polydor. of canado.



OUR YO-YO GOES
ONLY ONE WAY **UP!**

"YO-YO"
THE OSMONDS

K-14295



MGM
RECORDS

© 1971 MGM Record Corp.

insight&sound



NEW YORK—FROM A CHILD'S JOURNAL . . .

(NOTE: A few days ago a close friend of mine in England sent me this remarkable document. He says it's an entry in an incomplete and anonymous journal he found in the north of Britain, up around Newcastle, which is quite near Scotland. Except for a period here and a semi-colon there I've not changed a word of it. It's certainly a peculiar story, but I believe it. And maybe you will too . . . evl)

" . . . It's raining today. Yesterday, when the sun died, the sky turned gold with pink stripes all through it and running down like wet paint near the bottom and very far away, where the sky touches the earth. There was a strange kind of stillness then, sort of a rustling held in check, as if all the animals and birds and little things were holding their breath until the sun was laid to rest. And so it was, because the darkness brought the sounds: the chirruping and the soft bare padding, the delicate scraping and gentle sniffing.

It's raining today. Last night was the clearest night I've ever seen, like there was no air at all and, looking up, the stars burned and burned so strongly that my eyes got all watery and I had to turn away for a while. But I kept looking back at them because it was only them and the wind, skipping from tree to tree, that was left. It was cool but I lay down in a bed of leaves and I wasn't cold because the stars burned so brightly, and there were so many of them, they looked all sewn together. And I reached up and pulled my starquilt down and over myself and I was warm.

It's raining today. Something woke me up very early. Well, I wake up early anyway before hardly anyone else is up because, the world is mine then; I'm anyone I want to be. Anyway, I didn't wake up by myself today, something woke me. It could have been the rain, but I doubt it; I'm so used to being out in it, I like to be out in it. So maybe it was the voice. I've trained myself to listen for new sounds, and I'd never heard him before, so that must have been it after all.

Everything was white with the mist. I mean, you could hold your arm out in front of you and not see your hand for it. And it was wet. The rain sliced through the white without opening it up at all, you could just feel it, hitting your head and face and shoulders. Up close, I could just make out the lowest leaves sticking to their trees. And when I breathed, the wetness took all the air out of me. And all I could hear was that muffled dripping.

Then the voice came again, singing: "Morning has broken, like the first morning. Blackbird has spoken, like the first bird." I looked around and knew he was right. Today was like the first day I could ever remember in my life; almost as if I'd never lived before now. "Mine is the Sunlight; Mine is the Morning. Born of the One Light, Eden saw plain."

I went to find him. It wasn't easy in all that, and if I had to depend just on my eyes, I'd never have done it. But I had my ears. He was up on the moor, out away from the bracken, in amidst a big patch of deep purple heather that even the mist couldn't fade, though I really think it was trying.

And suddenly, I broke through the white, and there he was
I listen to the wind, the wind of my soul
Where I'll end up well I think only God really knows . . .

There they were, actually. He had long black hair and a beard all around his face. By his side sat this, well, cat. But if it was, I'd never seen one like it. It was small and long-haired and every so often, while he played a guitar, it would burst into sparks, flame up all yellow and orange for an instant. But there was never any smoke or heat like you get with real fire, and his hair never seemed bothered by it

I listen to my words but they fall far below
I let my music take me where my heart wants to go
I've swam upon the Devil's lake
But I'll never, never make the same mistake . . .

It was Teaser & The Firecat, I'd met, although I never did find out which
(Cont'd on page 32)

HOLLYWOOD—CANNED HEAT FANS SUPPORT FOR THE REDWOODS

A call to Skip Taylor's office yielded the information that the manager and producer of Canned Heat was laid up. But we did get to talk with his secretary and Gal Friday, Stephanie Brody, who got to telling us a little more about Taylor's Music Mountain project, which has, since last heard from, been formed into a non-profit California foundation. The idea behind it, and one that the music community is being urged to support, is to save some redwoods—specifically a huge grove of them in an upstate area called Skunk Cabbage Creek consisting of some 2000 acres, of which 1600 are virgin timber. The remaining 400 has already been logged by Humboldt County's Arcata Redwood Company. All of it is surrounded by the existing Redwood National Park, but is higher up so that it occupies a strategic ecological position as far as the park is concerned. Any damage through erosion, wind, fire or flood to Skunk Cabbage Creek would directly imperil the park.

The man behind the project, originally, was the late Alan Wilson, singer-composer of "On the Road Again" and "Goin Up the Country." Skip and Canned Heat, along with a number of other major groups, have pledged in his memory and on behalf of Music Mountain to donate all proceeds from at least one big concert during the coming year. (Canned Heat has two coming up in the next few weeks—a benefit for Mexican-Americans at East L.A. College, which will get TV coverage locally, and a San Diego gig at the Sports Arena. Then they're off on another European tour, through the end of November. Thus the timeliness of their latest sure-to-be-a-hit single for UA, "Long Way from L.A.")

Back to the redwoods: the goal of Music Mountain, which this tree-clad high-
(Cont'd on page 32)

Cat Stevens
Firecat
Canned Heat

Ko-Ko Joe

48-1011 b/w "I Feel for You"

Ko-Ko Joe

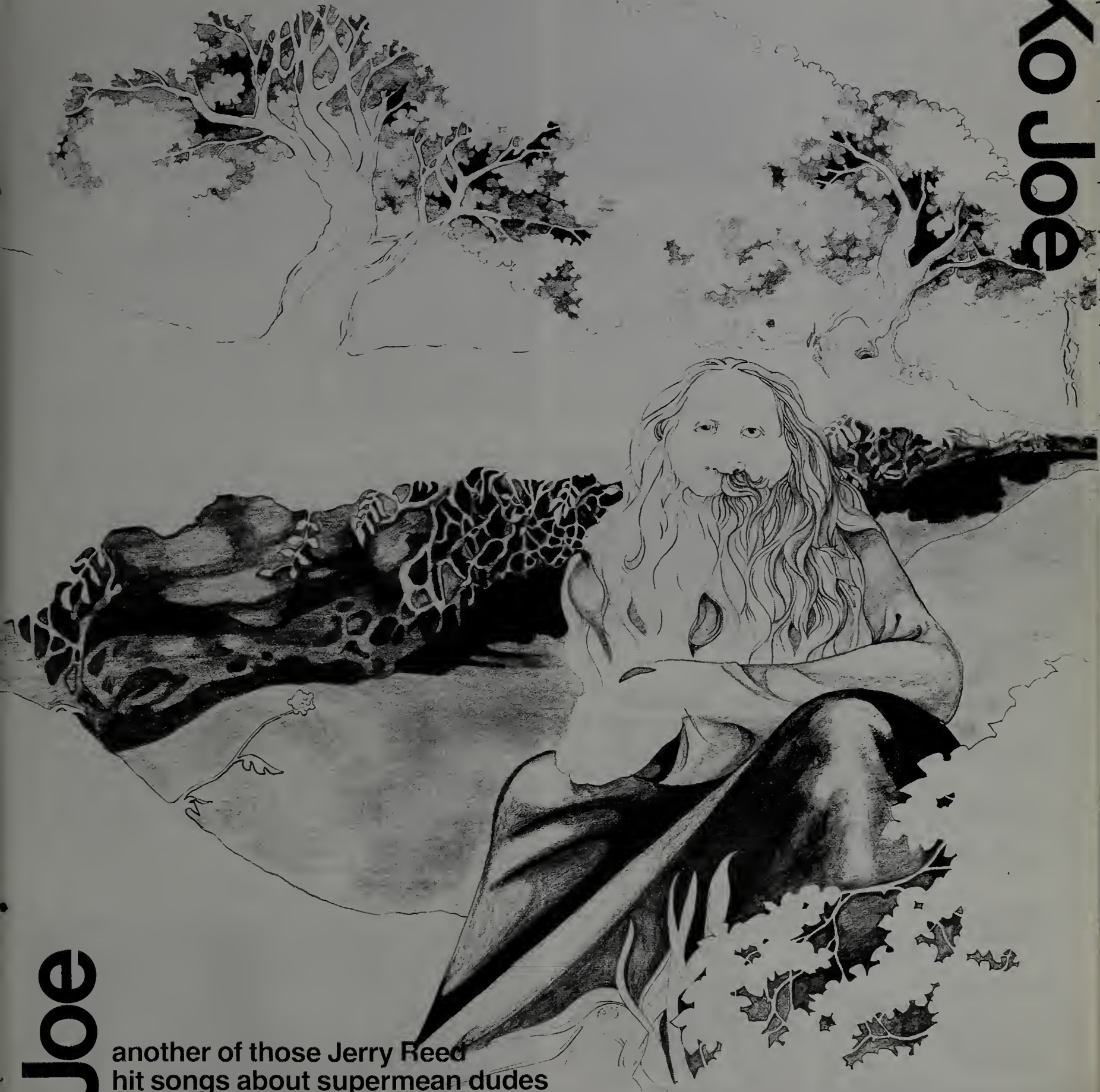

Ko-Ko Joe

another of those Jerry Reed hit songs about supermean dudes who come through.

A sure-to-be-smash followup to Jerry Reed's previous amazing "When You're Hot, You're Hot" and the just as successful "Amos Moses."

"Ko-Ko Joe"—a lowdown country strut that's got plenty to be proud of. From the upcoming Jerry Reed album of the same name.

CASH BOX	59	●
BILLBOARD	62	☆
RECORD WORLD	53	●

RCA
Records
and Tapes

Musical Season Is Taking Shape

NEW YORK—The new musical theatre season is taking firmer shape.

Two of Broadway's major musical attractions, "Jesus Christ Superstar" and "On The Town" started rehearsals last week for Oct. 12 and 31 debuts, respectively. "Superstar" is, of course, the spin-off of the giant recording success. Tom O'Horgan, who staged "Hair" and "Lenny" is mounting "Superstar." Jesus is played by Jeff Fenholt, who played the role in Robert Stigwood's "authorized" concert version, and Judas is played by black actor Ben Vereen. Decca, which has the original disk version, will also market this version.

"On The Town" is a 1944 success with a score by Leonard Bernstein, Betty Comden and Adolph Green. Ron Feld is director & co-producer. Starring is Phyllis Newman, wife of Green. No castor label yet, but Columbia does have what is considered an excellent recreation version starring Comden & Green with Bernstein conducting.

Two other Oct. openings include "Drat!" described as a musical burlesque, and an Israeli musical, "To Live Another Summer, To Pass Another Winter." Former goes into the McAlpin Rooftop Theatre on Oct. 18, and the latter is booked at the Helen Hayes for Oct. 21. A musical version of Truman Capote's "Grass Harp" premieres Nov. 2 at the Martin Beck. It stars Barbara Cook, Celeste Holm, Muriel Smith, Ruth Ford and Max Showalter. Ellis Rabb is directing, book and lyrics by Kenward Elmslie and music by Claibe Richardson.

Store Label Set In Fla.

LANCASTER, Pa.—Richard H. Allison, producer of musical stage shows for industry and currently active in rock music production, has announced the formation of Florida-based Store Records. The label will produce for the pop, soul, and MOR fields and is presently signing rock music groups and vocalists.

Allison, who is now establishing distribution for Store's first release—a single, The Geoffrey Stoner Band's "To Love Somebody" and Robert M. Esty II, and off-Broadway composer-arranger and director, who is handling talent development for the label, are currently headquartered in Lancaster. Store's corporate offices are located at 22 South Ocean Ave., Daytona Beach, Florida.

Some distribution arrangements for the new release have been set, Allison reported, but the company is seeking to augment its distribution in a number of markets.

Fast Eddy Master To RCA

NEW YORK—RCA Records has purchased and released a master produced by Jack Richardson of Nimbus 9 Productions, producer of The Guess Who. The record, "Bringing On Back The Good Times" is by the Canadian group, Fast Eddy, and was recorded in Toronto.

"Bringing On Back The Good Times" was released in Canada prior to RCA's release in the United States. Airplay that the record received in Canada prompted RCA's purchase for the U.S. It was purchased out of Chicago by RCA's Chicago A&R head, David Kirshenbaum.



SENSATIONAL SUMMER OF '71

LYNN ANDERSON
sings JOE SOUTH'S
"HOW CAN I UNLOVE YOU"
A 1-2 punch on
Columbia Records

*Thanks,
The Lowery Group*

NARAS Trustees Set Chicago Meet

NEW YORK — Discussion and action relating to categories and voting procedures for the 14th annual Grammy Awards, future cultural and educational involvement, including the NARAS Institute, the status of the Grammy Awards television special, possible creation of new chapters, and the election of new officers for the coming year will spotlight the full-scale meeting of the board of national trustees of the Record Academy (NARAS) from Friday, Sept. 10 through Sunday, Sept. 12 at the Drake Hotel in Chicago.

Hosted for the first time by the academy's Chicago chapter, the annual confab will bring together representatives of all five NARAS chapters. Joining out-going national president Irving Townsend and national administrator David Leanse from Los Angeles will be national treasurer Bill Cole, trustees Stan Farber, Larry Levine, Dave Pell, Mike Post, Paul Weston, Christopher Whorf, Peter Whorf and Lee Young, executive director Christine Farnon and finance committee member John Scott Trotter.

New York will be represented by 1st vice-president and trustee Father Norman J. O'Connor, trustees Manny Albam, Brooks Arthur, John Hammond, Johnny Pate and Phil Ramone, plus exec. director George Simon. National counsel Dick Jablow will also plane in from New York, as will finance committee representative F. M. Scott, III.

Coming up from Nashville will be vice-president and finance committee-man Wesley Rose, trustees Danny Davis, Bill Denny, Frank Jones, Glenn Snoddy and Bill Williams, with NARAS Institute Director Rick Powell filling in for Davis during the time he will be blowing his horn elsewhere. Exec. director Emily Bradshaw will also attend.

The Atlanta contingent, headed by national secretary and trustee Bill Lowery, will include trustee Maurice LeFebvre and exec. director Mary Talent.

Representing the home team will be chapter president and national trustee Paul Roewade, trustees Robin McBride and Bob Schiff and exec. director and meeting coordinator Charlotte Caesar.

Record Spectacular Re-Opens In N.Y.

NEW YORK—Record Spectacular's recording retail outlet in Flushing, Queens, N.Y. has re-opened following renovation after a major fire.

Merc's Bly Sees LPs-Lead To 45's

CHICAGO—Several singles from current albums are sparking what Mercury national singles promotion director Stan Bly predicts will build to an end-of-summer heat wave in singles activity for the company.

Bly indicated several examples of recent releases to emphasize his prediction. "Walk Easy My Son" by Jerry Butler has been released as a single following a generally good reception to it in his "Sagittarius Movement" LP. After performing the song on TV during a recent road tour, it received repeated requests leading to its release last week.

Similarly, the success of Chuck Mangione's LP "Friends and Love" and an earlier single, "Hill Where The Lord Hides", prompted the release of a second single, "The Feel of a Vision" b/w/ "And In The Beginning." The singles have served to broaden Mangione's audience and focus further attention on the LP.

"The Year Clayton Delaney Died" from Tom T. Hall's "In Search of A Song" album has broken into the charts and spread from initial c&w popularity into growing pop acceptance for Hall.

Bly said, "Our feedback process from the field alerts us to the potential of single hits contained within albums very soon after release and we're able to meet radio and consumer interest with product by the time that interest peaks to a demand for a single." Looking ahead, he expressed total enthusiasm for the recently released LP, "Look At Yourself" by Uriah Heep and said that the entire company is closely watching.

Melanie, Mills To Perform At Gallagher Fete

NEW YORK—Melanie and the Mills Brothers, two close friends of Bill Gallagher, former president of Famous Music Corp., have been selected to entertain on the evening of Sept. 22 in the main ballroom of the Waldorf-Astoria at the testimonial dinner which is being given in his honor. Joe D'Imperio, president of Feld Bros Management Corp. and Ringling Bros. and Barnum & Bailey Records, is chairman.

William B. Williams, WNEW deejay, will act as toastmaster for the evening. Two guests appearing on the dais will be Mitch Miller and William Randolph Hearst, Jr.

Gallagher will be the recipient of the annual Ed Wynn Humanitarian Award and all monies from this event are to be turned over to the American Parkinson Disease Association.



BIG BEGINNING AT BITTER END?: Ellen McKillwaine is shown making her debut at the Bitter End. She's an artist on Polydor, which is releasing her first LP soon. Peter Siegel, who discovered her in Woodstock, is producing.

SPANISH HARLEM ARETHA FRANKLIN Atlantic Hill & Range Trio Music
I'M LEAVIN' ELVIS PRESLEY RCA Elvis Presley Oten Music
GET IT WHILE YOU CAN JANIS JOPLIN Columbia Hill & Range Ragmar
DREAM LOVER BILLY "CRASH" CRADDOCK Cartwheel Hill & Range Fern
WHEN HE WALKS ON YOU JERRY LEE LEWIS Mercury Hill & Range Blue Crest
DON'T LET HIM MAKE A MEMORY OUT OF ME BILLY WALKER MGM Hill & Range S-P-R Music
I GOT A WOMAN BOB LUMAN Epic Hill & Range
LEAVE MY MAN ALONE RAELETTS Tangerine Tiger
WHEN TOMORROW TURNS TO YESTERDAY I DON'T DESERVE THIS BRYAN ST. THOMAS	Nickels & Dime Bennie Benjamin Music
THE ABERBACH GROUP 241 West 72 Street, New York, N.Y.	



INITIAL DISTRIBUTION—Sidney Seidenberg, president of SAS/Inc, who announced the signing of The Patterson Singers, is seen above distributing their newest single release on the Atco Label. The Patterson Singers were signed to the label by exec vp Nesuhi Ertegun early this year. The Patterson Singers are currently on tour with B. B. King. An album release is scheduled in August.

Pop Picks

BARBRA JOAN STREISAND—Columbia KC 30792

Whoever is advising Barbra Streisand on her material these days should be commended. This is an absolutely superb collection of songs perfectly suited to this artist's personality and style. One listen to her reading of John Lennon's "Mother" is all it takes to fall in love all over again with this incredibly gifted performer. She is equally effective on the buoyant "Space Captain," "Love," (another Lennon song) and Laura Nyre's "I Never Meant To Hurt You." For extra good measure, there is also Barbra's recent single, "Where You Lead." Oh, and a beautiful poster too. If talent and taste will out, this will be a top selling album.



BLESSED ARE . . . —Joan Baez—Vanguard VSD-6570/1

Now, more than ten years after she first appeared on the folk scene, Joan Baez continues to carry it on. This two record set features twenty songs, plus a bonus "little record" of "Maria Dolores" and "Plane Wreck At Los Gatos (Deportee)." Miss Baez' own compositions, particularly "Gabriel And Me" and "The Hitchhikers' Song," are marked by a beautifully poetic flow. Her readings of "Put Your Hand In The Hand," the Jagger-Richard work "Salt Of The Earth" and Mickey Newbury's "The 33rd Of August" are flawless and tasteful. Her surprise top ten hit, "The Night They Drove Old Dixie Down" is here too. A superb offering from first track to last.



I THINK WE'RE ALL BOZOS ON THIS BUS—The Firesign Theatre—Columbia C30737

Madness is afoot and not a minute too soon. The Firesign Theatre, most inventive and amusing of all the groups working in recorded comedy, have concocted another irrepressible brew, stepping deftly along channels of absurdity and firing the odd shot here and there. This one is about a bus trip into the future but it really is about much more. It's a tribute to Firesign that their albums stand up after repeated plays and this one is no exception. It should be a high chart LP.



ONE DOZEN ROSES—Smokey Robinson & The Miracles—Tamla T312L

Newest bouquet from Smokey and the gang is sparked by "The Tears Of A Clown" and "Crazy About The La La La." But among the other satisfying items are the group's treatment of Simon & Garfunkel's "Cecilia," a delightfully talky song titled "No Wonder Love's A Wonder" and "The Hunter Gets Captured By The Game." Another top notch entry from this act.



THE LIFE AND TIMES OF COUNTRY JOE AND THE FISH FROM HAIGHT-ASHBURY TO WOODSTOCK—Vanguard VSD-27/28

If there can be such a thing as a greatest hits album for Country Joe and his band, this is probably it, since in this two record set can be found the songs which catapulted the Fish from their niche as the house band for Berkeley to a prominent position in pop music. Along with such staples as "I-Feel-Like-I'm-Fixin'-To-Die Rag" and "Flying High," there are some live tracks, recorded at Fillmore's East & West and Woodstock. About half the album is previously unreleased material and the rest is CJ&the Fish at their familiar best.



TRAFALGAR—Bee Gees—Atco SD 7003

How can you not like the Bee Gees? How can you describe the feeling of cool breeziness which you feel upon encountering their "Trafalgar?" How can you single out "Israel," "Don't Wanna Live Inside Myself" and "Somebody Stop The Music" without mentioning that the entire album is a joy? How can you say enough about the orchestral accompaniment directed by Bill Shepherd? How can you imagine a world without the Brothers Gibb? How can you mend a broken heart?

THE FIRST GREAT ROCK FESTIVALS OF THE SEVENTIES—ISLE OF WIGHT/ATLANTA POP FESTIVAL—Columbia G3X 30305

This is a three record live album selling for the price of two disks. While the sound and quality of performance varies from cut to cut, there are plenty of things to recommend it, not the least of which is the opportunity to hear the late Jimi Hendrix on three songs, Mount in turning in a strong effort, Poco delivering in fine fashion, Johnny Winter And laying down some blues and Sy churning up "Stand" and "You Can Make It If Your Try." Since open air rock festivals may soon be a thing of the past, fans should want to latch onto this set if only for memory's sake.

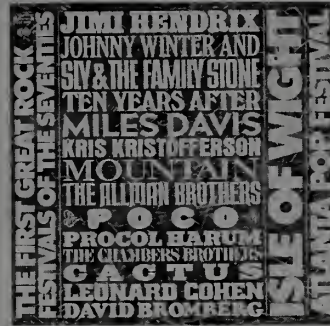

SOUL TO SOUL—Original Soundtrack—Atlantic SD 7207

Released simultaneously with the motion picture, this album should shape up as one of the big soul sellers of the year. It was recorded live and stomping at an independence day celebration in Ghana, West Africa and it features such powerhouse acts as Wilson Pickett, Ike & Tina Turner and Roberta Flack. That would usually be enough for excitement aplenty but the set also boasts Eddie Harris & Les McCann, the Staple Singers and the Voices Of East Harlem. Should take right off and become a major chart item.



B. B. KING: LIVE AT THE REGAL—ABC S-724

Many longtime fans consider this to be B. B. King's finest recording. Made in Chicago in 1964, it has now been repackaged and re-issued, largely for the benefit of the young and predominantly white audience which has "discovered" B.B. during the past couple of years. This artist's charm and his unique style of working and relating to an audience make this an exceptional live album and the songs are blues, blues, blues. And more blues. "Every Day I Have The Blues," "You Upset Me Baby" and John Lee Hooker's "It's My Own Fault" are three of the ten selections which B.B. and his Lucille get to doing.

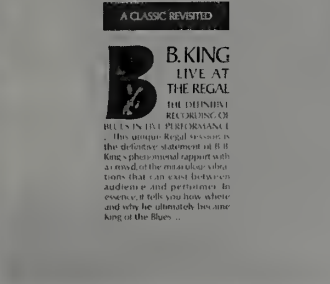

GREATEST HITS, VOL. 2—Four Tops—Motown M740L

The title tells the story of this new release from one of the premier R&B hitmaker groups. Among the goodies to be found herein: "If I Were A Carpenter," "Still Water (Love)," "Still Water (Peace)," "You Keep Running Away," "Just Seven Numbers (Can Straighten Out My Life)" and "Don't Let Him Take Your Love From Me." Six more tracks round out an appealing package from a consistently fine quartet.



Pop Best Bets

THE TIME TO LIVE IS NOW—Buzzy Linhart—Kama Sutra KSBS 2037

Buzzy is the guy next door, if you should be fortunate enough to live next to a freaked-out musical longshoreman, or a someone who bears a resemblance to a cross between a steel worker and a guy who smiles for his living. Carly Simon has made his "And The Love's Still Growing" legend, and here it is in a strikingly original setting. "Friends" or the title track could easily catch the Top 40 market unawares while "Cheat-Cheat-Lied" provides him with something to run bare-foot through, scat singing and having one helluva time. This LP is fun, pure and simple, and it should bring out his fans in droves.

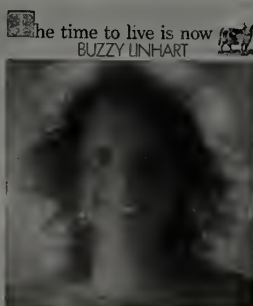

THE BEST OF KOOL & THE GANG—De-Lite DE-2009

If you're going to have a gang, it should be like Kool's. They have put together a kind of funky sound which is quite unmistakably their own. "Kool And The Gang," "Kool's Back Again," "Let The Music Take Your Mind" and "The Penguin" are the really strong tracks here but the remaining eight numbers are in the same vein. So the LP should do nicely.

The Best Of Kool And The Gang

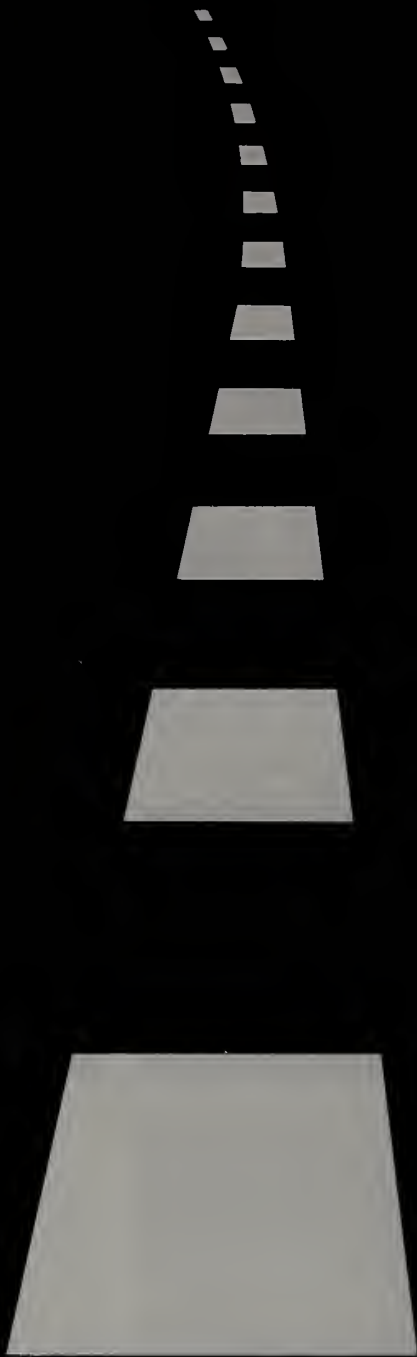

CANNED HEAT HAS THE TRAVELIN' BLUES
AGAIN. & THAT'S GOOD. THEIR EXPLOSIVE
NEW SINGLE, "LONG WAY FROM L.A." IS
GETTING HEAVY AIR PLAY FROM HUNTINGTON
BEACH TO HELSINKI - & A LOT OF OTHER
PLACES A LONG WAY FROM L.A. - TURN
THE HEAT ON, QUICK! 
"LONG WAY FROM L.A." UNITED ARTISTS RECORDS.
B/W "HILL'S STOMP" # 50831.
PRODUCED BY SKIPTAYLOR.

1	TAPESTRY CAROLE KING (Ode 77009)	1	33	UP TO DATE PARTRIDGE FAMILY (Bell 6059) (8 6059) (5 6059)	29	67	CHAPTER 2 ROBERTA FLACK (Atlantic 1569) (TP 1569) (CS 1569)	68
2	EVERY PICTURE TELLS A STORY ROD STEWART (Mercury SRM 1-609) (MCR 1-609) (MCR4 1-609)	6	34	A SPACE IN TIME TEN YEARS AFTER (Columbia KC 30801) (CA 30801) (CT 30801)	47	68	CURTIS/LIVE CURTIS MAYFIELD (Curton CRS 8008)	62
3	EVERY GOOD BOY DESERVES FAVOR MOODY BLUES (Threshold THS 5) (24805) (24604)	7	35	THE BEST OF GUESS WHO (RCA LSPX 1004) (P8S 1710) (PK 1710)	31	69	LOVE IT TO DEATH ALICE COOPER (Warner Bros. WS 1883) (8 1883) (5 1883)	73
4	WHO'S NEXT THE WHO (Decca DL 79182) (6 79182) (73 79182)	5	36	GOLDEN BISQUITS 3 DOG NIGHT (Dunhill DS 50098) (8 50098) (5 50098)	36	70	RAY STEVENS' GREATEST HITS (Barnaby Z 30770) (CA 30770) (CT 30770)	80
5	RAM PAUL & LINDA McCARTNEY (Apple SMAS 3375) (8XT 3375) (4XT 3375)	2	37	LEE MICHAELS V (A&M SP 4302) (8T 4302) (CS 4302)	40	71	EMERSON, LAKE & PALMER (Cotillion SD 9040)	64
6	MUD SLIDE SLIM JAMES TAYLOR (Warner Bros. WS 2561) (8 2561) (5 2561)	3	38	WHAT YOU HEAR IS WHAT YOU GET IKE & TINA TURNER (United Artists UAS 9953)	27	72	I DON'T KNOW HOW TO LOVE HIM HELEN REDDY (Capitol ST 752) (8XT 762) (4XT 762)	77
7	CARPENTERS (A&M SP 3502) (8T 3502) (CS 3502)	4	39	SURRENDER DIANA ROSS (Motown MS 723) (M8 1723) (M75 723)	42	73	ANOTHER TIME, ANOTHER PLACE Engelbert Humperdinck (Parrot 71048)	—
8	STICKY FINGERS ROLLING STONES (Rolling Stone COC 59100) (TP 5910) (CS 5910)	8	40	SONGS FOR BEGINNERS GRAHAM NASH (Atlantic SD 7204) (TP 7204) (CS 7204)	28	74	STEPPENWOLF GOLD (Dunhill DS 50099) (8 50099) (5 50099)	76
9	JESUS CHRIST SUPERSTAR (Decca DXSA 7206) (6-6000) (73-6000)	10	41	SO LONG BANNATYNE GUESS WHO (RCA LSP 4574) (P8S 1) (PK)	50	75	PAUL AND PAUL STOOKEY (Warner Bros. WS 1912) (8 1912) (5 1912)	87
10	AQUALUNG JETHRO TULL (Reprise MS 2035) (8 2035) (5 2035)	12	42	CARLY SIMON (Elektra EKS 74082) (T8 4082) (54082)	30	76	GODSPELL ORIGINAL CAST (Bell 1102)	81
11	SHAFT ORIGINAL SOUNDTRACK (Enterprise EN 2 5002) (EN 25002) (ENC 25002)	18	43	SURVIVAL GRAND FUNK (Capitol SW 764) (8XT 764) (4XT 764)	32	77	HOT TUNA ELECTRIC RECORDED LIVE (RCA LSP 4550) (P&S 1762) (PK 1762)	65
12	SOUND MAGAZINE PARTRIDGE FAMILY (Bell 6064) (8 6064) (5 6064)	20	44	SKY'S THE LIMIT TEMPTATIONS (Gordy GS 957) (G8 1957) (G75 957)	41	78	SUMMERTIME HERB ALPERT & The Tijuana Brass (A&M SP 4314) (8T 4314) (CS 4314)	72
13	B, S, & T; 4 BLOOD SWEAT & TEARS (Columbia KC 30590) (CA 30590) (CT 30590)	9	45	FIREBALL DEEP PURPLE (Warner Bros. BS 2564) (8 2564) (5-2564)	67	79	FREEDOM MEANS DELLS (Cadet CA 50004)	84
14	WHAT'S GOING ON MARVIN GAYE (Tamla TS 310) (T8 1310) (M75 310)	11	46	BRYDMANIAX BYRDS (Columbia KC 30640) (CA 30640) (CT 30640)	43	80	VOLCANIC ACTION OF MY SOUL RAY CHARLES (ABC 726)	61
15	STEPHEN STILLS 2 (Atlantic SD 7206) (TP 7206) (CS 7206)	13	47	YOU'VE GOT A FRIEND ANDY WILLIAMS (Columbia KC 30797) (CA 30797) (CT 30797)	56	81	VIKKI CARR'S LOVE STORY (Columbia C 30662) (CA 30662) (CT 30662)	85
16	L. A. WOMAN DOORS (Elektra EKS 75011) (8T 5011) (55011)	17	48	THE UNDISPUTED TRUTH (Gordy G 955) (G8 1955) (G75 955)	58	82	DEATH WALKS BEHIND YOU ATOMIC ROOSTER (Elektra EKS 74094) (8T 4094) (54094)	75
17	THE SILVER TONGUED DEVIL AND I KRIS KRISTOFFERSON (Monument A 30679)	15	49	OSIBISA (Decca DL 75285) (6-75285) (73-75285)	38	83	CHICAGO TRANSIT AUTHORITY (Columbia GP8)	78
18	4 WAY STREET CROSBY, STILLS, NASH & YOUNG (Atlantic SD 2-902) (T 8902) (S 2-8902)	19	50	BURT BACHARACH (A&M SP 3501) (87 3501) (CS 3501)	44	84	PEARL JANIS JOPLIN (Columbia KC 30322) (CA 30322) (CT 30322)	83
19	TARKUS EMERSON, LAKE & PALMER (Cotillion SD 9900) (TP 9900) (CS 9900)	16	51	I'M JUST ME CHARLEY PRIDE (RCA LSP 4560) (P8S 1730) (PK 1730)	48	85	RELICS PINK FLOYD (Capitol SW 759) (8XT 759) (4XT 759)	74
20	MASTER OF REALITY BLACK SABBATH (Warner Bros. WS 2562) (8 2562) (5 2562)	52	52	PARANOID BLACK SABBATH (Warner Bros. WS 1887) (M8 1887) (M5 1887)	51	86	FILLMORE EAST, JUNE 1971 MOTHERS (Bizarre MS 2042) (M8 2042) (M5 2042)	92
21	ONE WORLD RARE EARTH (Rare Earth RS 520) (R8 1520) (R75 520)	24	53	MAYBE TOMORROW JACKSON 5 (Motown MS 735) (M8 1735) (M75 735)	49	87	LOVE LETTERS FROM ELVIS ELVIS PRESLEY (RCA 4530) (P8S 1748) (PK 1748)	82
22	TEA FOR THE TILLERMAN CAT STEVENS (A&M SP 4280) (8T 4280) (CT 4280)	21	54	HAMILTON, JOE FRANK & REYNOLDS DUNHILL (DS 50103)	46	88	RAINBOW FUNK JR. WALKER & ALL STARS (Soul S 732) (S8 1732) (S75 732)	86
23	ARETHA LIVE AT FILLMORE WEST ARETHA FRANKLIN (Atlantic SD 7205) (TP 7205) (CS 7205)	22	55	MR. BIG STUFF JEAN KNIGHT (Stax STS 2045) (ST 8-2045) (STC 2045)	59	89	SHE'S A LADY TOM JONES (Parrot XPAS 71046) (M 79846) (M 79846)	88
24	BLUE JONI MITCHELL (Reprise MS 2038) (8 2038) (5 2037)	25	56	WHAT THE WORLD NEEDS NOW IS LOVE TOM CLAY (Mowest 103-L) (MW 103-T) (MW 103-C)	60	90	I WON'T MENTION IT AGAIN RAY PRICE (Columbia C 30510) (CA 30510) (CT 30510)	89
25	POEMS, PRAYERS AND PROMISES JOHN DENVER (RCA LSP 4499) (P8S 1711) (PK 1711)	23	57	CHICAGO III (Columbia CT 30110) (CA 30110) (CT 30110)	54	91	ROCK ON HUMBLE PIE (A&M SP 4301) (8T 4301) (CS 4301)	97
26	THE ALLMAN BROTHERS BAND AT FILLMORE EAST (Capricorn SD 2-802)	14	58	HOT PANTS JAMES BROWN (Polydor PD 4054) (8F 4054) (CF 4054)	71	92	THE LONDON HOWLIN' WOLF SESSIONS (CHESS 60008)	98
27	INDIAN RESERVATION RAIDERS (Columbia C 30768) (CA 30768) (CT 30768)	26	59	NATURALLY THREE DOG NIGHT (Dunhill DSX 50088)	45	93	C'MON EVERYBODY ELVIS PRESLEY (RCA Camden 2518)	90
28	THE DONNY OSMOND ALBUM (MGM SE 4782) (8130-4782) (5130-4782)	37	60	11-17-70 ELTON JOHN (Uni 93105) (8 93105) (2 93105)	53	94	THE PARTRIDGE FAMILY ALBUM ORIGINAL TV CAST (Bell 6050) (8 6050) (5 6050)	93
29	HOMEMADE THE OSMONDS (MGM SE 4770) (8130-4770) (5130-4770)	35	61	THIRDS JAMES GANG (ABC ABCX 721)	55	95	KING CURTIS LIVE AT FILLMORE WEST (Atco SD 33-359)	101
30	CHASE (Epic E 30472) (CA 30472) (CT 30472)	34	62	IF I WERE YOUR WOMAN GLADYS KNIGHT & THE PIPS (Soul SS 731) (S8 1731) (S75 731)	57	96	WRITER CAROLE KING (Ode 77006)	96
31	LEON RUSSELL & THE SHELTER PEOPLE (Shelter SW 8903) (8XT 8903) (4XT 8903)	33	63	ABRAXAS SANTANA (Columbia KC 30130) (CA 30130) (CT 30130)	63	97	GRAND FUNK LIVE (Capitol SWBB 633)	100
32	JUST AS I AM BILL WITHERS (Sussex SXBS 7006)	39	64	CLOSE TO YOU CARPENTERS (A&M 4271) (8T 4271) (CS 4271)	70	98	GIVE MORE POWER TO THE PEOPLE CHI-LITES (Brunswick BL 754170)	115
			65	SLY & THE FAMILY STONE GREATEST HITS EPIC KE 30325 (CA 30325) (CT 30325)	69	99	SOMETHING ELSE SHIRLEY BASSEY (United Artists 6797)	91
			66	SWEET BABY JAMES JAMES TAYLOR (Warner Bros./7 Arts) (WS 1843) (8 WM 1843) (CWX 1843)	66	100	THE LAST TIME I SAW HER GLEN CAMPBELL (Capitol SW 733) (8XT 733) (4XT 733)	94



TOP 100 Albums

101 TO 150

101	HOW HARD IT IS BIG BROTHER (Columbia C 30738) (CA 30738) (CT 30738)	111	SOMETIMES I JUST FEEL LIKE SMILIN' BUTTERFIELD BLUES BAND (Elektra EKS 75013)	—	135	HANGING IN THERE HUDSON & LANDRY (Dore 324)	130
102	ONE FINE MORNING LIGHTHOUSE (Evolution 3007)	102	119 POTLATCH REDBONE (Epic E 30109)	107	136	YOU'VE GOT A FRIEND JOHNNY MATHIS (Columbia C 30740) (CA 30740) (CT 30740)	—
103	FRIENDS & LOVE CHUCK MANGIONE (Mercury SRM 2-800)	79	120 LOVE STORY ORIGINAL SOUNDTRACK (Paramount PAS 6002)	132	137	MANNA BREAD (Elektra EKS 74086) (F&T 4086) (TC 54086)	131
104	JAMES GANG LIVE IN CONCERT (ABC 733)	—	121 TUMBLEWEED CONNECTION ELTON JOHN (Uni 73096)	119	138	LOVE STORY ANDY WILLIAMS (Columbia KC 30497) (CA 30497) (CT 30497)	135
105	YOU'RE MY MAN LYNN ANDERSON (Columbia C 30793) (CA 30793) (CT 30793)	95	122 SUMMER OF '42 ORIGINAL SOUNDTRACK (Warner Bros. WS)	—	139	EVERYTHING IS EVERYTHING DONNY HATHAWAY (Atco SD 332)	—
106	BOOKER T & PRISCILLA (A&M SP 3504) (8T 3504) (CS 3504)	105	123 P G & E (Columbia C 30362) (CA 30362) (CT 30362)	104	140	MARY MARY TRAVERS (Warner Bros. WS 1907) (8 1907) (5 1907)	142
107	SOUL TO SOUL ORIGINAL SOUNDTRACK (Atlantic SD 7207)	—	124 SHA NA NA (Kama Sutra 2034)	114	141	ELTON JOHN (UNI 73090) (8 73090) (2 73090)	136
108	GREAT CONTEMPORARY INSTRUMENTAL HITS RAY CONNIFF (Columbia C 30755) (CA 30755) (CT 30755)	—	125 TRUTH IS ON ITS WAY NIKKI GIOVANNI (Right On 05001)	145	142	SECOND MOVEMENT EDDIE HARRIS & LES McCANN (Atlantic SD 1583) (TP 1583) (CS 7205)	137
109	MANCINI CONCERT HENRY MANCINI (RCA LSP 4542) (PBS 1754) (PK 1754)	103	126 CONTACT FREDA PAYNE (Invictus SMAS 7307) (8XT 7307) (4XT 7307)	108	143	WHERE I'M COMING FROM STEVIE WONDER (Tamla TS 308) (TS 1308) (T75 308)	139
110	AFTER THE GOLD RUSH NEIL YOUNG (Reprise RS 6383) (8RM 6383) (CH 6383)	110	127 IN THE GARDEN GYPSY (Metromedia KMD 1044)	121	144	MARK ALMOND (Blue Thumb)	109
111	CHRISTIAN OF THE WORLD TOMMY JAMES (Roulette SR 3001)	117	128 YES ALBUM (Atlantic SD 8283) (TP 8283) (CS 8283)	123	145	COSMO'S FACTORY CREEDENCE CLEARWATER REVIVAL (Fantasy 842)	140
112	WAR WAR WAR COUNTRY JOE MCDONALD (Vanguard VSD 79315)	113	129 BROKEN BARRICADES PROCOL CARUM (A&M SP 4294) (8T 4294) (CS 4294)	124	146	WOODSTOCK ORIGINAL SOUNDTRACK (Cotillion SD3-500) (TP 33-500) (CS 33-500)	144
113	SINFONIAS ALDO DE LOS RIOS (United Artists UAS 6802)	99	130 IF 3 (Capitol SMAS 820) (8XT 820) (4XT 820)	122	147	NATURAL MAN LOU RAWLS (MGM SE 4771)	—
114	MAGGOT BRAIN FUNKADELIC (Westbound WB 2007)	116	131 8TH DAY (Invictus ST 7306) (8XT 7306) (4XT 7306)	125	148	LAYLA DEREK AND THE DOMINOS (Atco SD 2-704) (TP 704) (CS 704)	143
115	SUMMER SIDE OF LIFE GORDON LIGHTFOOT (Reprise MS 2037) (8 2037) (5 2037)	106	132 THIS IS A RECORDING LILY TOMLIN (Polydor 25-4055)	128	149	HERE COMES THAT RAINY DAY FEELING AGAIN FORTUNES (Capitol ST 809) (8XT 809) (4XT 809)	146
116	MESSAGE TO THE PEOPLE BUDDY MILES (Mercury SR 1-608) (MC8 1-608) (MCR4 1-608)	118	133 DEJA VU CROSBY, STILLS, NASH & YOUNG (Atlantic SD 7200) (TP 7200) (CS 7200)	127	150	BRIDGE OVER TROUBLED WATER SIMON & GARFUNKEL (Columbia KCS 99-14) (18 10 0750) (14 10 0750) (16 10 0750)	147
117	TOMMY THE WHO (Decca DXSW 7205) (6-2500) (73-2500)	120	134 MORNING NOON & NITE-LITERS NITE-LITERS (RCA LSP 4493) (PBS 1798) (PK 1712)	134			



R & B TOP 60

1	SPANISH HARLEM Aretha Franklin (Atlantic 2817)	1	16	MAKE IT FUNKY James Brown (Polydor 14088)	26	31	SHE'S ALL I'VE GOT Freddie North (Mankind 12004)	41	46	BREEZIN' Gabor Szabo (Blue Thumb 200)	57
2	AIN'T NO SUNSHINE Bill Withers (Sussex 219)	2	17	TAKE ME GIRL Junior Walker (Soul 35084)	19	32	LOVE THE ONE YOU'RE WITH Isley Bros. (T-Neck 930)	16	47	MISS JACKSON'S DAUGHTER Randolph Walker (Law/Ton 1552)	50
3	STICK UP Honey Cone (Hotwax 7106)	5	18	WOMEN'S LOVE RIGHTS Laura Lee (Hotwax 7105)	29	33	MR. BIG STUFF Jean Knight (Stax 0088)	17	48	YOU'RE THE ONE FOR ME Joe Simon (Spring 115)	27
4	MAYBE TOMORROW Jackson 5 (Motown 1186)	4	19	GOT TO GET OVER THE HUMP Simtek & Wiley (MR. CHAND 8005)	20	34	BLACK SEEDS KEEP ON GROWING Main Ingredient (RCA 740517)	49	49	THAT'S THE WAY A WOMAN IS Messengers (Rare Earth 5032)	—
5	TIRED OF BEING ALONE Al Green (Hi 2194)	6	20	SLIPPED TRIPPED AND FELL IN LOVE Clarence Carter (Atlantic 2818)	25	35	FUNKY L.A. Paul Humphrey (Lizard 1009)	37	50	GIVE THE BABY ANYTHING THE BABY WANTS Joe Tex (Dial 1008—Dist. Mercury)	—
6	THE LOVE WE HAD Dells (Cadet 5683)	9	21	I LIKES TO DO IT Peoples Choice (Phil La of Soul 349)	7	36	CALL MY NAME, I'LL BE THERE Wilson Pickett (Atlantic 2824)	52	51	DADDY LOVE Gi-Gi (Sweet S-001-S)	54
7	IF YOU REALLY LOVE ME Stevie Wonder (Tamla 54208)	11	22	A PART OF YOU Brenda & The Tabulations (Top & Bottom 408)	34	37	GHETTO WOMAN B. B. King (ABC 11310)	44	52	DO IT (THE FUNKY DANCE) Dave "Baby" Cortez (Sound-Pak SPM 1002)	56
8	UNTIL THEN I'LL SUFFER Barbara Lynn (Atlantic 2812)	10	23	MERCY MERCY ME Marvin Gaye (Tamla 54207)	13	38	IT'S THE REAL THING Electric Express (Cotillion-Linko 1001)	21	53	SURRENDER Diana Ross (Motown 1188)	—
9	BREAKDOWN Rufus Thomas (Stax 98)	15	24	HIJACKING LOVE Johnnie Taylor (Stax—ST 0096)	46	39	FRIENDS BY DAY What Nauts (Stang 5030)	43	54	S.O.S. Winfield Parker (Spring 116)	—
10	K-JEE Nite Liters (RCA 0461)	12	25	YOU SEND ME Ponderosa Twins Plus 1 (Horoscope 102—All Platinum)	48	40	I WASN'T THERE Roy C. (Alga—AL 1007-A)	53	55	YOU'VE GOT TO CRAWL 8th Day (Invictus 9098)	—
11	WEAR THIS RING Detroit Emeralds (Westbound 181)	14	26	FEEL SO BAD Ray Charles (ABC 11308)	36	41	YOU'VE GOT A FRIEND Roberta Flack, Donny Hathaway (Atlantic 2808)	28	56	IT'S IMPOSSIBLE New Birth (RCA 74-0520)	—
12	WHAT YOU SEE IS WHAT YOU GET Dramatics (Volt 3058)	8	27	LUCKY ME Moments (Stang 5031)	32	42	A NATURAL MAN Lou Rawls (MGM 14262)	47	57	LOOK WHAT WE'VE DONE TO LOVE Glass Bottle (Invictus 9097)	—
13	SMILING FACES SOMETIMES Undisputed Truth (Gordy 7180)	3	28	I LOVE THE WAY YOU LOVE Betty Wright (Alston 4594)	31	43	HOW'S YOUR LOVE LIFE BABY Ted Taylor (Ronn 52)	45	58	JUST MY WAY OF LOVING YOU Garland Green (Cotillion 44126)	42
14	A THIN LINE BETWEEN LOVE AND HATE Persuaders (Atco 6822)	23	29	MAKE IT WITH YOU Raifi Pagan (Wand 11236)	33	44	ALL DAY MUSIC War (U.A. 50815)	51	59	GROOVING OUT ON LIFE Fredrick The II (Vulture 5002)	—
15	TRAPPED BY LOVE Denise LaSalle (Westbound W182)	18	30	1-2-3-4 Lucky Peterson (Today 1503)	38	45	A NICKEL & A NAIL O. V. Wright (Black Beat 602)	—	60	CAN YOU GET TO THAT Funkadelic (Westbound 185)	—

cash box / album reviews

Pop Best Bets

BLACK MAGIC WOMAN—Fleetwood Mac—Epic EG 30632

This is a two record package consisting of early Fleetwood Mac things. The excellence of the songs and the relative obscurity of "Fleetwood Mac" and "English Rose" makes this a reissue of more than passing interest. Twenty-four songs in all, including the legendary "Shake Your Money Maker" and "Albatross." Title tune, which of course was later recorded by Santana, is another standout. A welcome reminder of what an important group this was.



TOUGH AND TENDER—Charlie Starr—Prophecy SD 6052

When the person in the adjoining studio dropped in to say how great he thought this album was going, blind singer-guitarist Charlie Starr had to be convinced that it was indeed James Taylor paying him the compliment in the form of three tunes: "Riding On A Railroad," "One Man Dog" and "Don't Talk Now." So they became part of the finished product, along with material from Joni Mitchell, Carole King and some gifted original numbers (especially "When Does A Man Become A Man"). Charlie has been getting press that's just short of phenomenal on his recent tour; reviews and sales here should confirm the double meaning inherent in his last name.



LABELLE—Warner Bros. 1943

Just off a U.S. tour with The Who and with their organization solidly behind them, expect this soul trio to make big inroads into the progressive and r&b markets simultaneously. Patti LaBelle and her women whittle a tune down to its barest essentials and then build it back up in their own image. Thus standbys like "Wild Horses" and "Time & Love" take on new shades of excellence. LP contains both sides of their single ("Morning Much Better" "Shades of Difference") and both album and 45 should benefit from the other's exposure. Strong come-back for a trio who's managed to do well since their "Junkman" days by becoming one of the most sought-after back-up acts in the business.

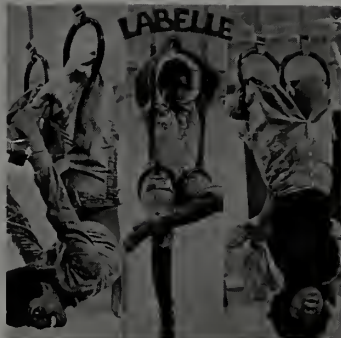

40 MILES PART WOODSTOCK—Jeremy Storch—RCA LSP 4541

A former band-fellow of Mountain's Leslie West (in a group called the Vagrants), Jeremy makes his own statements for the second time on LP. This outing, he is much more relaxed and so is better able to excite and enrapture an audience that's ready to sit back and hear some piano-rock and piano-poetry. Although shades of Laura Nyro and Neil Young crop up, his sound is quite unique and while it may take some getting into, the substance one reaches for the effort expended more than justifies the journey. "Spend Your Life With Me" and "Smooth Southern Born Lady" will get the airplay and should spark the album to a hearty buyer reception.



SILENT NO MORE—Theodore Bikel—Star ST 119-18

An album with musical as well as historical interest. These are "freedom songs" of Soviet Jews, smuggled out of the U.S.S.R. and artfully interpreted by the master of Hebraic music, Theodore Bikel. Profits from the sale go to a scholarship fund for Soviet Jews at The Hebrew University, but the act of purchase is more than charity. Bikel has done a totally professional job here and buyer interest engendered by the cause will be rewarded with a thoroughly moving and compelling package of 11 tunes.



GIVE ME A CLEAN HEART—James Cleveland And The Southern California Community Choir—Savoy MG-14270

In the field of gospel music, James Cleveland reigns supreme. The many awards he has won over the years, including a Grammy nomination, can attest to this. Teamed with the Southern California Community Choir he presents a formidable collection of eight gospel tunes, including "I Came To Jesus," "He Will Come In A Hurry" and "There's A Bright Side Somewhere." Also featured as soloist is dynamic Annette May who is something to hear. Enthusiasts of the best in gospel sounds will want to own this disk.



GUESS WHO GOLD—Catching up with The Guess Who in Indianapolis prior to their date at the Indianapolis State Fair, RCA Records' president Rocco Laginestra and vp of commercial operations, Mort Hoffman, present the group with their seventh Gold record for "The Best of The Guess Who". The gold record presentation was made in the office of Indianapolis Mayor Richard Lugar. Pictured left to right are, Hoffman, Laginestra, and The Guess Who; Jim Kale, Gary Peterson, Greg Leskin, Burton Cummings, and Kurt Winter.

LP Royalties To Angela Davis

NEW YORK — Bob Thiele, president of Flying Dutchman Records, says that arrangements have been completed whereby Angela Davis will receive royalties on the sales of "Soul and Soledad," an album recently released by Flying Dutchman records. Royalties will go directly to the "National United Committee To Free Angela Davis." Representing the committee were its national coordinators, Franklin Alexander and Fania Davis Jordan.

Initial response to the spoken word album by Miss Davis "has been overwhelming," Thiele reported. Thiele also commented that "whatever one believes about Angela Davis, it is truly clear that an opinion cannot be formed honestly without hearing from Miss Davis herself. On this album we all have that opportunity."

Hendrix Track LP To Reprise

NEW YORK — Reprise Records will shortly release a Jimi Hendrix album, "Rainbow Bridge." The album contains previously unrecorded material and is the soundtrack to "Rainbow Bridge," a 90-minute film of a Hendrix concert last summer on the volcanic island of Maui in Hawaii.

The new Hendrix album includes "Ezy Rider," "Look Over Yonder," "I Hear My Train A'Comin'," "New Rising Sun," "Bleeding Heart," "Dolly Dagger," and "Pali Gap."

Esposito To Coast

NEW YORK — Bob Esposito, professional manager of Larry Shayne Music, leaves for the west coast on Sept. 12 for a week's stay. He'll look for new material and place songs. He expects to meet with Henry Mancini and Bobbie Gentry and a number of indie producers.

'Bark' Gold

NEW YORK — Jefferson Airplane's new album, "Bark," with which the group is introducing its own record label, Grunt, was certified as a Gold Album by the Recording Industry Association of America within a week of its release date.

Manufactured and distributed by RCA Records, the Grunt label came into being with the signing last month of a new contract between Jefferson Airplane and RCA Records.

Although "Bark" is the first Gold Album for the Grunt label, Jefferson Airplane has four other gold awards on the RCA Victor label—"The Worst of Jefferson Airplane," "Surrealistic Pillow," "Crown of Creation" and "Volunteers."

The album has been simultaneously released as a Stereo 8 cartridge and as a cassette.

'Boys' Brings Gold

HOLLYWOOD — Freda Payne's Invictus single "Bring the Boys Home" has been certified as an RIAA Gold Record. The second million-seller for the "Band of Gold" artist, this one hit 1,008,000 a week Friday (Aug. 27).

The Lowery Group

SENSATIONAL SUMMER OF '71

Just released and
everybody's spinning
"YO-YO"

THE OSMONDS
sing it on MGM.

Produced by Rick Hall.
CASH BOX #57

ATTORNEY

For Law Department major diversified entertainment company headquartered in L.A. To handle legal matters leading record company with top labels. Requires 2-5 years broad record experience. Career opportunity with potential for activity other fields of entertainment law.

Reply to Box 899

Cash Box, 1780 Broadway, N.Y.C. 10019

3 British Acts Signed To London

NEW YORK—Three acts on the current British scene have just been signed by London Records with new LP's due for all three, according to Walt Maguire, vice president for pop A&R.

Leading the talent is the well-known blues group, Chicken Shack. An album on London's subsidi Deram label is anticipated for Oct. Chicken Shack is managed by the Harry Simmonds interests, which also handle the Savoy Brown Band.

Also signed is the Hardin-York group from England. The first album on London under the new deal, "For the World," contains songs and pro-

duction by Eddie Hardin. The set is in current release in England and will be rush-released here.

Drummer Pete York is an alumnus of the original Spencer Davis Group, which scored with such hits as "Gimme Some Lovin'" and "I'm a Man," with shout vocals by Steve Winwood. Hardin is also an alumnus of another chapter of the Spencer Davis Group, having taken over the keyboard, guitar and vocals chair originally occupied by Winwood. The four-man current Hardin-York outfit is expected to tour the U.S. later this year.

A third new pactee in the London family is Miller Anderson, lead singer with the Keef Hartley Band. Anderson who also composes a great deal of his own material, will be represented by an album, "Bright City," on the Deram label.

Douglas Opens Office In L.A. Under Willen

NEW YORK—Douglas Records has opened a west coast office at 262 N. Beverly Drive, Beverly Hills.

While the main office for Douglas books, records and films remains in New York, record sales, promo and publicity functions will have their primary base out of Los Angeles.

Phil Willen has been appointed exec. manager of Douglas Records, and will coordinate activities between Douglas Records and Columbia Custom Labels, as well as handle in-house sales and promotion supplementing Columbia's efforts at reaching alternative markets Douglas has tapped in the past. Willen comes to Douglas with 16 years experience in the record business, most recently as western regional manager for Pickwick International.

Music Publisher seeking young, aggressive person interested in career with extremely active company as assistant to top level administrative executive. Send resume: Box 900

Cash Box,

1780 Broadway, New York 10019.

ATTENTION DEALERS!

IF YOU ARE HAVING DIFFICULTY GETTING AMERICA'S TOP GOSPEL & JAZZ RECORDS CALL OR WRITE TO US DIRECT FOR OUR CATALOG & SERVICE

SAVOY

RECORD COMPANY, INC.
56 FERRY ST. NEWARK, N.J. 07105
(212) WO 2-3354
(201) 344-1400

MCA Sales Meet Sees Reg. Shift

UNIVERSAL CITY, CALIF. — Rick Frio, MCA Records' national sales director, chaired a week-long clinic just before Labor Day for all district sales managers and home-office management. The agenda included a thorough sales and promotion briefing on each new album scheduled for fall release and updated campaign plans for the best-selling "Jesus Christ Superstar" LP. Increased sales effort on behalf of the latter aims to take advantage of the Broadway opening of the rock opera in October.

Frio also revealed that the mid-west states would be divided between two districts (heretofore one) due to stepped-up sales volume and activity in that area.

MCA's former assistant midwest district sales manager, Dave Wulfsohn, headquartered in Milwaukee, will now be district sales manager for the upper midwest. This area will encompass Chicago, Milwaukee, Minneapolis, St. Louis, Kansas City and Des Moines. Wulfsohn began his record career in retail as mid-west sales rep for Kapp Records.

Bill Glaseman, the company's mid-west district sales manager, will henceforth cover all other areas in the region.

Also attending last week's clinic at the Universal Tower here were Sam Passamano, eastern district sales manager, based in Philadelphia; Carmen LaRosa, southern district sales manager, from Miami; and Tom Rodden, west coast district sales manager, from San Francisco.

Return Of Kingstons?

HOLLYWOOD — The original Kingston Trio (Dave Guard, Bob Shane and Nick Reynolds), generally credited as the group that popularized contemporary folk music, is on the verge of being reorganized and resurrected, according to a Capitol Records' spokesman.

Since 1958, when the trio was first organized, the group has sold more than 18,000,000 records and earned approximately \$12,000,000. Of the 28 albums they have recorded, eight are certified million-dollar sellers, and their imposing list of single smashes includes "Tom Dooley," "Tijuana Jail," "M.T.A.," "Worried Man," "Where Have All the Flowers Gone," "Greenback Dollar," and "Reverend Mr. Black" (featuring John Stewart, who replaced Dave Guard in the early 60's).

Guard, who had retired to Australia, is now living in San Francisco. All original members have been contacted and, according to the Capitol informant, are anxious to cut an album of current folk-oriented tunes. Currently under discussion: a club date kick-off for the LP, possibly at the Troubadour in L.A.

Group disbanded four years ago, announcing that each would go his own way, that they had become victims of musical type casting. Audiences, they said, wanted to hear "only the same old songs sung in the same old way."

Herb Gordon Para Promo Chief

NEW YORK—Tony Martell, president of Famous Music Corporation, has announced the appointment of Herb Gordon to director of national promo for Famous Music. He will be responsible for coordinating and directing promotion and exploitation of Paramount Records and all other labels owned or distributed by Famous. Gordon plans to immediately start organizing all field promo and distribution communications into a "tight and effective force."

Gordon has been actively involved in record promo for the past 12 years, most recently as director of promotion for MCA Records, which included the Decca, Kapp, and UNI labels.

Fine Sunflower Promo Director

HOLLYWOOD—Mack David, president of Sunflower Records, reports the appointment of Jerry Fine as national promo manager for the label. He will report to Rick Sidoti, general manager of Sunflower, which is distributed by MGM Records.

David said that there will be in-depth concentration on Sunflower artists and that Fine and Sidoti will work hand-in-hand in developing and promoting all product on the Sunflower label.

Fine has a background of more than 15 years in the record industry and started out in the business as an entertainer. He also worked as a program director on WILD in Boston and was also heard on the air as a deejay. Prior to joining Sunflower, Fine was in charge of national sales and promotion for Amaret Records. He has held numerous other exec positions with Take 6 Enterprises Inc., operated his own independent promo company — Disc Promotions Inc. and also promo/sales manager for Disc Distributors in Boston and for Records Inc.



Sidoti, Fine

Buddah LP's

(Cont'd from p. 9)

("16 Candles") and the Brooklyn Bridge ("Worst That Could Happen") through the original recordings. Set also contains Maestro's version of "The Love's Still Growing" and the new Bridge single, "Wednesday In Your Garden".

The Edwin Hawkins Singers return with "Children (Get Together)," produced by Stan Vincent, who took the Stairsteps to gold with "O-oh Child." Dorothy Morrison, who sang the lead vocal on the original "Oh Happy Day," has rejoined the group. Album presents new Hawkins material plus a re-arrangement of Paul Anka's "My Way".

"Man And Boy" is the soundtrack album to Bill Cosby's forthcoming feature film, a post-Civil War drama with Douglas Turner Ward. Music is by J. J. Johnson with supervision by Quincy Jones. The main title theme is sung by Cosby ("Ain't No Sunshine"), who also wrote the lyrics. "Man And Boy" appears on the Buddah-distributed Sussex label.

Moering To Kinney

HOLLYWOOD — Columbia Records' southern California promo chief Bob Moering will be exiting that slot next week to join the Kinney record group in a similar post, it was learned by Cash Box.

Moering served in various promo posts for Columbia over the past nine years. Prior to that he worked out of Al Sherman's Record Sales distributorship.

For Kinney Moering will be working under Ted Rosenberg, general manager of the company's west coast branch, and Bob Murphy, sales manager. Covering the eleven western states, Moering's title will be "promotion coordinator," and he'll be involved in product coordination as well as branch advertising.

Moering was recently caught in action by NBC-TV's "First Tuesday" show in a segment on Janis Joplin.

Three Dog Night

(Cont'd from p. 7)

their jobs and there were enough of them to keep things in order." (Note: Three Dog Night drew a record crowd to the relatively new Salt Palace that night, with over \$70,000 in gross receipts, surpassing the previous record held by Glen Campbell.)

Jacobs cites his trouble-free record, and on-the-ball security on the part of promoters, in Dallas, Atlanta and Pittsburgh earlier this summer, with crowds ranging from 25,000 to 30,000.

But the San Diego incident was enough, he says, to scare him into making sure on future concert dates that nothing like it happens again.

Another condition Jacobs is placing on upcoming Three Dog Night performances, in the interests of safety, is a guarantee of reserved seating, i.e., no "festival" or first-come-first-served seating.

Sperber Answer

(Cont'd from p. 9)

ferred in the business relationships of Mrs. Sperber and the Original American Touring Company through 'the filing and serving of vexatious court actions' and the threat of such actions around the country . . ." The verified answer filed in U.S. District Court of New York further counter-claimed for the sum of \$20 million in damages for libel and slander of Mrs. Sperber and the Original American Touring Company through a plethora of press releases issued by the plaintiffs and their attorneys.

In a relatively new application of an established theory of law, the complaint went on to claim exemplary damages of \$10 million for the violation of Mrs. Sperber's civil rights by the Stigwood Group's attempt to systematically destroy her ability to make a living.

Judge Pierce, who had dissolved a temporary restraining order against Mrs. Sperber and the Original American Touring Company only two weeks earlier because he had "serious doubts as to the plaintiffs' ability to demonstrate the probability of success on the merits," found that the Stigwood Group had not sufficiently made out a case for a preliminary injunction sought by the Stigwood Group against Mrs. Sperber's use of the name "The Original American Touring Company".

"Plaintiffs have failed to present evidence of confusion sufficient to meet their burden on a motion for a preliminary injunction," he concluded.

While he prohibited the use of the title of the work in the advertisements for the Original American Touring Company concerts Judge Pierce went on to state that such a decision "would not preclude defendants from identifying the individual song titles in the publicity for their performances."

Seals & Crofts Earl Scaggs & Family Jerry Corbett & Charlie Daniels

CENTRAL PARK, NYC—Capitol's Jerry Corbett has joined forces with Charlie Daniels in a country-rock band which is capable of a wider variety of moods than most. Opening with a song pleading, won't you give a "Country Boy" a chance, the crowd gave them at least that to allow them to prove that they've got more than ersatz emotions to back up their act. Corbett, a former member of the Youngbloods is long, tall, handsome and totally professional in contrast to Daniels who is a chubby cut-up from start to finish. Together they drive home a country message hard or soft, and they had no trouble behind the wheel.

Randy & Gary Scruggs record without pops for Vanguard, and although a bit shaky and nervous, the band managed to meld the country side of Dylan with some nice electrified down-home instrumentation. Originals like "The Lowlands" were received with the same warm response that greeted more familiar tunes such as "You Ain't Goin' Nowhere." But the reception they received alone became a wilder enthusiasm still when daddy Earl hit the stage. The originator of the three-fingered banjo technique and the composer of the now legendary "Foggy Mt. Breakdown" may have lost a partner (Lester Flatt) but he's gained an act which should appeal to country fans (because he is one himself), the sincerest music lovers of the younger generation (because this is REAL music) and an Ed Sullivan crowd as well (because the charm of the family act is irresistible). The Columbia artist surely has a better deal today than he ever did, but the sounds are still the simple yet flashy bluegrass variety which made him famous.

Seals & Crofts have fanatical followers too who scream like banches until the first few notes begin, and then become utterly silent so as to worship their idols. The duo also plays some bluegrass, but they are at their best on their more contemporary, introspective numbers. They look quite content up there on stage; satisfied minds make plenty of good music. **r.a.**

Quincy Jones / Roberta Flack

GREEK THEATRE, L.A.—Quincy Jones and Roberta Flack put together a smashing show for this pre-Labor Day gig. The band that Jones assembled was, for starters, one of the basic ingredients in that success since it brought together some of the best first-desk men and soloists in the business. But the two stars did the rest.

A kind of Renaissance man of music—composer, conductor, arranger and hip m.c. (on this occasion)—Jones got things off to a very special beginning by announcing that he and Miss Flack would share the stage for the evening. It was going to be a sort of family affair, he said, and indeed it seemed that way. The big-band selections alternated with Miss Flack's solos, she at the piano or standing with hand mike or just sitting on the sidelines obviously having a whale of a good time. And the friendly, unbuttoned mood on stage was completely infectious if the response from the sold-out audience was any gauge.

Altogether there were few surprises (one, a beauty, was Jones' new theme music for "Ironside"), and the predictably professional way the concert its course contributed much to the pleasure it gave. Miss Flack was in top form, Jones the master craftsman at work and at his best. **c.b.**

Flying Burrito Bros. Cheech & Chong

BITTER END, NEW YORK CITY—Slowly, and most carefully, A&M Records is breaking every artist on their label. And next in line are the Flying Burrito Brothers. In a time when more and more country music seems to be infiltrating the pop and MOR charts, the Burritos seem the likely choice to make their move.

The Burritos play a special kind of country flavored music which sets them apart from all other artists in their genre. Their songs are sad and bluesy and always project an image of loneliness and hurt. Their songs cry out to be felt—and not just listened to. They ask you to respond with thought rather than with hand clapping.

The Flying Burrito Brothers combine both music and vocals ever gracefully. The two are never in conflict, but rather, serve to compliment each other resulting in a set of precisely planned and expertly performed songs. At their Bitter End debut, the Burritos galloped through a brief set of material pulled from their three A&M albums. From their latest LP effort, the Burritos performed "White Line Fever," "Tried So Hard," "Four Days Of Rain," and "Why Are You Crying," a likely candidate for their next single release.

Sharing the bill with the Burritos were another A&M act, Cheech & Chong. Not the least bit musical, C&C have been described as the first "hard rock comedy team." Their routines are inventive, contemporary and more important, appealing to all age groups. They can be best appreciated live, though their album is extremely representative of their stage act.

Together on the same bill, the Flying Burrito Brothers and Cheech & Chong deliver an unusually entertaining evening of music and comedy. And a well balanced evening at that!

k.k.

Miss. Fred McDowell Tom Everett Steve Haggard

GASLIGHT II, NYC—His last album for Capitol was called "I Do Not Play No Rock And Roll" and his patter tries to make the same point. But when Mississippi Fred McDowell plays "My Babe" or "Shake 'Em On Down," you just know that this is the epitome of blues, whether it be blues-rock, -jazz or -folk. "I don't do much," he continued. "Just kind of play these guitars, doing the same thing every night." Well, if Fred is monotony, lots of folks crave it. His bottleneck style is not his only trademark; his voice is more distinctive than most bluesmen. Together they sing of troubles and hard times: the good old way.

If an artist sat down with the most popular of the teen fan mags as his models and tried to come up with an ideal pop idol, it is unlikely he could chisel features finer than those of Tom Everett. But musically he's a lot more than cute; the RCA artist has an inherent yodel-quaver and Ian Tyson inflection in his voice which is most striking. His earlier tunes, many of which appear on his "Porchlight On In Oregon" LP tend to exaggerate these features at the expense of melodies, however, and his tremolos can carry themselves off-base when they are uncontrolled. A song he just finished, "Did I Get A Rotien Apple Baby?" speaks well for his future. While the Oregonian might have chose the country route, rock audiences in the near future will be glad he chose to sing for them.

Steve Haggard (no relation to Merle) opened the show with undistinguished original tunes but a rich, gutsy voice. **r.a.**

Ten Years After

CONVENTION CENTER, LAS VEGAS—Just a few hours before Ten Years After's appearance for a capacity crowd of 8,000, the group's exceptional lead guitarist Alvin Lee had been taking the press to task for categorizing his group with the likes of Grand Funk and Led Zeppelin. He resented the implication that Ten Years After was nothing more than another "power group."

While the British quartet is certainly capable of making much more creative music than either of their "power" contemporaries, their Las Vegas concert would have served very poorly to reinforce Lee's argument.

From the very first number, Lee was pulling out all of the guitar tricks he knew—from barring with the microphone stand to hammering the neck of his instrument to achieve an uncanny synthesizer effect. While the guitarist is obviously an accomplished musician (as was excitingly illustrated by his frequent scat-like vocals, which paralleled his guitar line), his bravura showmanship was definitely in questionable taste.

Ten Years After is distinctly not a power group, nor do they rely very heavily on over-loud amplification. Rather, their forte is speed. Bassist Leo Lyons, who is accurately credited with being "the fastest bass player working today," provided most of the musical support for the group, working very closely (both physically and musically) with Lee. Drummer Ric Lee managed to keep the pace of the music, but delivered an exceptionally unimaginative and disappointing solo during "Las Vegas Stripper." Chick Churchill on organ provided some tasty musical asides, but his function was more often limited to filling out the sound rather than contributing much of his own.

Only once did the group slow the furious pace, noticeably with their "Blues in C," but even that number succumbed to a get-'em-to-their-feet finale. **c.v.n.**

Wishbone Ash / Help

WHISKY A GO GO, L.A.—The two groups booked for this five-night run share two mutual ties—they both record for Decca, and they are both managed by Michael Gruber's Just Us Productions. Aside from that, they have little in common.

Help is what used to be called a Power Trio—meaning that they turn their amps up to 10 and from then on it's every man for himself. Cream was a Power Trio. Grand Funk is one. Hep stands somewhere between the best and the worst, beating your brain to a pulp with their unceasing hurricane of sound but doing so with at least some knowledge of how to play their instruments. And Jack Merrill even plays his guitar with his tongue, just—well, almost—like Jimi Hendrix.

But groups like this have never "needed" critics, and doubtless never will. Help looks good on stage, and keep getting better at whatever it is they do, each time around. Chances are, given the right breaks, they'll be monsters.

The opening night crowd had the Whisky packed full (not too many freebies, either), and apparently it was Wishbone Ash that did most of the pulling.

Judging from their two albums, the group has an instrumental virtuosity well above most of the competition, and they play long, fairly complicated but moody pieces displaying the talents of their two lead guitarists.

It was somewhat disappointing, then, to see them stumble through a program of half-baked blues. One wonders if they changed their program for the type of crowd attracted to the Whisky. Of course it must be mentioned that most of the club regulars didn't seem to mind a bit. **t.e.**

Mountain Black Oak Arkansas Jo-Jo Gumme

HOLLYWOOD PALLADIUM, L.A.—"You've got to bring your own cotton," said the guard at the door with a wink of his eye. "That's for your ears."

Inside, Lawrence Welk and his Champagne Music Makers had abandoned their home temporarily, and in their place was a hard and heavy bill led by Windfall Records' Mountain.

Trimmed to a trio for the occasion (no mention was made as to why their pianist was absent), Mountain kept things moving at high pitch; confirming their place at the top of the rock heap. They're probably the oddest looking supergroup around: Felix Pappalardi looking a bit like Frank Zappa in a spangled outfit, and Leslie West grunting and groaning as he dwarfs his guitar, are probably no-one's idea of what a teen-age idol looks like. But their music more than compensates for their physical appearance; it hits you smack-in-the-face with West's first chord, and the impact doesn't let down for a minute.

Black Oak Arkansas is a hard-driving Atco Records band with a lot of character. Much of it comes from Jim Mangrum's "hot and nasty" (his term) vocalizing, but the other five members of the band should not be underestimated. They can—and did—work an audience to a frenzy with their only somewhat put-on raunchiness.

Asylum Records' Jo-Jo Gunne opened the show 25 minutes late, which did nothing to help their lukewarm reception. They play a brand of hard rock which is indistinguishable from that of probably hundreds of other bands. At present, their strong points seem to be limited to the hype value of numbering two former members of Spirit among their ranks, and of having David Geffen as their manager. **t.e.**

Jimmy Witherspoon Eric Burdon

ASH GROVE, L.A.—A few moldy figs might object, but this pairing has a chance to open up a whole lot of new ears. It's a blend of the established and the relatively new that might lead to the development of wider audiences for both Witherspoon and Burdon.

'Spoon, very dapper in a double-breasted white suit, took charge over the proceedings as an elder statesman must; his performance, though, didn't hint to the fact that he is something like twice his partner's age. Burdon, more casually dressed, was singing better than he has in years. He's a clear example of a talent that promises a lot more than he generally delivers. The experience with Witherspoon can only be doing him good.

The material is fine, ranging from standards like "Going Down Slow" and "Drifting Blues" to newer songs like James Taylor's "Steamroller" (with a lot of the parody inherent in the original version missing in Witherspoon's) and the duo's single, "Soledad."

Backing them is a four-piece band, Tovarich. Lead guitarist John Sterling tried his damndest to sound like Jimi Hendrix, and drummer George Suranovich pounds away like crazy, so the group's "sound" is awfully strong. They should lay back a bit and let the vocals stand out more by themselves. In another context, though, they'd be fine.

The one-night Ash Grove stand, a benefit performance for members of the Living Theatre held political prisoners in Brazil, was the group's third time out in public. If they continue to develop, and if Burdon can control his often-overboard mannerisms, it could be a most fortuitous development for both vocalists. **t.e.**

NEW YORK (Cont'd from page 22)

was which and I don't think it much mattered. I do know that his name is Steve, whatever others he also has. "I've been far away for a long time," he said. Where? "Trapped in a land where everything is blown up bigger than life and try as you may, you can't see yourself, only images, and they're not you but that's all you see. One day you wake up, and the images don't seem so strange anymore. That's the time. Either you realize that you've changed to fit your images and get out, or you'll never know and they'll consume you until there's nothing left but them."

Don't you feel a change a comin' from the other
side of town
Breakin' down the walls of silence, liftin' shadows
from your mind
Placin' back the missing mirrors, that before you
couldn't find
Livin' mysteries of emptiness that yesterday left
behind
And we all know it's better
Yesterday has passed
Now let's all start livin'
For the one that's gonna last . . .

So you got out? "Yes, I became ill. It was bad. I swam the Devil's lake and saw the floor of Hell. They thought I was dead. And I was, almost. But I came back." And he began to sing

Ruby, my love
You'll be my love
You'll be my sky above
Ruby, my light
You'll be my day and night . . .

And the cat was playing too, a mandolin or balzouki, running these beautiful fast riffs around the chords Steve was playing. And as Steve began to sing in Greek, they locked arms and started to dance. He beckoned me to join them, but I was afraid. I don't much like people. But he said, "Come. Join us," and even the cat was grinning and they showed me how. It was no effort; I just knew or I didn't care if I did or not, I'm not sure which. But it didn't matter because we were all together, laughing in each other's faces

If I laugh just a little bit
Maybe I can forget the chance I didn't have
To know you
And live in peace, in peace . . .

We left the heather, then, and it's brightness left us as we made our way to the coastline. The sky had grown dark as we had danced but I only noticed it now. It was very low, all slate grey with thick dark clouds racing in from the water. We'd left the mist behind and you could still see it clinging to the land inland from the cliffs. It was a hard climb down; very steep, with the earth so wet that it broke off and slid away in front of our feet, jolting us every few seconds. Steve carried the cat, but as soon as we made the beach-like spit of land, he put it down. It immediately took off after some land crabs, shooting sparks playfully as they crawled sideways down to the water. We followed slowly

How can I tell you that I love you?
I love you,
But I can't think of right words to say.
I long to tell you
That I'm always thinking of you
I'm always thinking of you,
But my words just blow away . . .

A wind was rising and the water looked like steel, somehow stiff and hard, like a stage backdrop. And the rain came hard at us, then, whipping our loose clothes around us. I looked down and the cat was back at Steve's side. "I'm an optimist, I think. Do you know what that means?" Yes. "Yeh, generally; about the world, other people. Myself? That's another story. It changes all the time and sometimes I'm pessimistic about me."

Wherever I am girl
I'm always walking with you
I'm always walking with you
But I look and you're not there.
Whoever I'm with,
I'm always talking to you
I'm sad that you can't hear . . .

It was really dark now, not like a night-darkness, warm and close, but all overhead it was black and brown and the world was lit only by a thin fierce line of watery yellow down near where the sky meets the sea. Everything was changing color, lit as they were by the strange line of light. The rain, all warm and salty, became stronger and the world seemed to be splitting down the center. "There's a girl," Steve said, looking at that terrible crack of light as it began to widen. "Every twelve months or so, we run into each other; it could be in Cannes or Marrakesh. We're together those few moments and then we must go on, to continue or lives; go wherever we must."

I need to know you
To feel my arms around you
Feel my arms surround you
Like sea around the shore.
Each night I pray
And hope that I might find you
Because hearts can do no more.
But it always ends up to one thing, money
As I kneel upon the floor,
And I can't think of right words to say.

My eyes were closed. I had been seeing with my ears, Steve singing softly, very close to me; his guitar gentle and comforting. Once I thought I heard, way off in the distance, a horn and a flute and the waltzing of a harpsichord which were, maybe, made by the cat. Then again it could have been the sky crying, I

HOLLYWOOD (Cont'd from page 22)

land is called, is to get itself bought, which will take between \$7 and \$8 million. Says Skip Taylor in a letter soliciting funds, "It is important to emphasize that nearly all contributions are matched by funds from the Department of National Parks and Recreation, the Federal agency which arranges the purchase of projected National Park additions . . . \$1.5 million has been raised already." It's also worth emphasizing that, when purchase of the land is completed, the Feds, through the Parks Department, will become responsible for its maintenance.

How can we help? Well, with money. But it's all deductible (for those of you out in melody-land who can afford to file anything more than the Short Form). And for this, promises Taylor, "Music Mountain and you will be one step closer to the reality of the preservation of the redwoods. In acknowledgment of your contribution you will receive a full-color Music Mountain decal, and your name will be added to the ever-growing list of concerned individuals which will eventually appear on a grand, commemorative, bronze plaque at the MUSIC MOUNTAIN NATIONAL PARK!" The address is 6331 Hollywood Boulevard (Suite 211), Hollywood, Calif. 90028.

WEST COAST GIRL OF THE WEEK—

Sue Finn, who since March of this year has willfully assisted and abetted, as secretary and assistant, Dino Airali, national promotion director over at Shelter Records.

Sue began life in the music business some five years ago toiling for Bernard/Williams/Price, personal managers of Andy Williams, Roger Miller and others. "In the meantime," she says, "I had always been interested in music and records, and to me promotion seemed to be one of the most important aspects of a record company. Then I went to New York and for a time worked for Zell Enterprises Booking Agency. I came back to L.A. and went to work at Blue Thumb." There, as secretary to Don Graham, then the label's national promotion director, she found bliss—that is, the right job. But Don left, and with a minimum of scurrying around Sue found again "the position I always wanted to be in."

As for hobbies, she cooks, crochets, writes and spends a lot of time exploring second-hand book stores and flea markets for old clothes and furniture. But on the job, where she is known as "Sweet Sue from Shelter," she really digs making phone calls to station directors and PDs in reference to Shelter product and "hearing their reactions in dealing with a 'promotion girl.'"



SOUNDTRACKS—Sonny Charles, who wrote Presley's latest hit, "I'm Leavin'," is booked for a return to P.J.'s early October . . . Mike Curb recorded Buddy Greco's opening with Sammy Davis at the Sands in Las Vegas, so look for a live Buddy and Sammy album from MGM before too long. christie barter

really can't be sure.

For a long time there was a great silence. The rain had stopped and I could smell the fish-salt of the sea again. I opened my eyes and the world had changed. A tiny piece of the sun wrinkled and winked off the moving face of the water, and there was gold in the world again

Now I've been happy lately, thinking about the good
things to come,
And I believe it could be, something good has begun.
Oh, I've been smiling lately, dreaming about the
world as one,
And I believe it could be, some day it's going to come . . .

Steve had the cat in his arms, and they were singing to each other, voices merging so that it sounded, at one moment, like one, and later, like many. Their eyes were locked together, and I noticed, for the first time, that they were the same; shape and color melting all together. They sang, and that piece of sun began to dance

Now I've been crying lately, thinking about the world as it is,
Why must we go on hating, why can't we live in bliss . . .

And something was happening, forming out there just beyond the limit of my eyes. It was something that you could only catch a glimpse of out of the corners of your eyes, and even then I'm not sure if everyone could see it. It was impossible to see anything directly. And I knew, don't ask me how, that what Steve and the cat were singing, was causing this thing to happen

Get your bags together, come bring your good friends too,
'Cause it's getting nearer, it soon will be with you.
Come and join the living, it's not so far from you,
And it's getting nearer, soon it will all be true . . .

And they turned to me, holding out their arms. I touched them and something exploded in the back of my head. Their voices rose, not louder, just wider and deeper

Oh, Peace Train, sounding louder,
Ride on the Peace Train
Ooaheeyaoaah!
C'mon, the Peace Train! . . .

It was that piece of sun, they were working on. It pulsed and grew and bathed us and got closer to us. Or maybe it was that we got closer to it. It really didn't matter. What mattered was the singing. Just wider and deeper with new voices joining in, growing and expanding and I heard my voice singing with them and knew that was part of it, a very important part

For out on the edge of Darkness
There rides the Peace Train.
Oh, Peace Train,
Take this country,
Come take me home again! . . ."

eric van Iustbader



Country Artist Of The Week: **TOM T. HALL**



ONE HUNDRED HITS, PLUS—Tom T. Hall is a journalistic creator who writes of life with a lyrical and musical pen and sings of it with a personal knowledge.

Today, the Mercury recording artist is one of the most cited and sought after songwriters and entertainers in the field, having written more than 400 songs—including the multi-million selling hit of "Harper Valley P.T.A.". Tom's accomplishments as an entertainer and recording artist have put him on top of the ladder with his releases of "I Washed My Face In the Morning Dew," "Week In A Country Jail," "Homecoming," "One Hundred Children," and his current hit, "The Year That Clayton Delaney Died." He has appeared on several network TV shows including "Hee Haw," "The Johnny Cash Show," and NBC's Special entitled "Harper Valley U.S.A." which he co-wrote and starred in. Recently invited to join the Grand Ole Opry, Tom also added another star to his list of achievements when he was recently contracted to write and sing the soundtrack score for a Paramount motion picture tentatively titled "Deadhead Miles."

The son of an Olive Hill, Kentucky minister, Tom is a member of the board of directors for both the Nashville Songwriters' Association and the Country Music Association. He is produced on Mercury by Jerry Kennedy. Personal management is through Hillman Hall, Hall Family Enterprises, with bookings handled by the Bob Neal Agency.

Jim Reeves Fest An Annual Event

NASHVILLE — The first annual Jim Reeves Memorial Country Music Festival was recently celebrated in Carthage, Texas. Sponsored by the Panola County Chamber of Commerce, the event drew an enthusiastic following from all over the Southwest to the artist's birthplace.

T. G. Davis, president of the Chamber of Commerce, announced that plans and work are already under way to make the occasion next summer bigger and better. These plans include enlarging the festival to two days, appearances by internationally known country music artists, a new talent competition and a Jim Reeves Scholarship Award to be given by Mary Reeves, the singer's widow.

According to Mary, the Jim Reeves Enterprises will be giving its fullest cooperation to the event, proceeds of which are going to worthy Panola County charities.

Mareno Sets Up MGB Productions

NASHVILLE — Ricci Mareno, head of Terrace Music has announced the forming of MGB Productions, representing Mareno, Gillespie and Black.

Mareno has been the head of Terrace Music for the past three years and has recently produced "Gwen (Congratulations)" and "I Don't Know You Anymore" on Tommy Overstreet. Jack Barlow is the latest artist to be added to the roster and Mareno said this would be the first project for the new company. Mareno will remain executive producer for Tommy Overstreet and Jack Barlow while other artists will be produced by Jerry Gillespie and Charlie Black. Mareno said he has searched for three years to find the right combination and finally he has it.

MGB Productions will negotiate production with any company. Artists now on the MGB roster are: Tommy Overstreet, Jack Barlow, Durwood Haddock, Blake Emmons, Tracy Miller, and Stan Dee. Mareno also announced that Allie Cunningham would be in charge of Terrace Music's publishing companies.

46th Annual Birthday Celebration Agenda For Grand Ole Opry Set

NASHVILLE — The official announcement has been made of the 46th Annual Birthday Celebration of WSM's Grand Ole Opry here. The convention registration office opened on Sept. 1st for the event which is scheduled for Oct. 14-16.

Centered mainly in the Municipal Auditorium in Music City, space will be limited and only the first 6,000 requests for registration will be filled.

Cost of the 1971 registration has been set at \$20.00 and because of the tax structure of the Opry Trust Fund, it is required that two separate checks accompany all registrations, one for \$10.00 made to the Opry Trust Fund with the second check for \$10.00 to the Opry Convention Fund. The Trust Fund monies will be used, as has been customary, for aiding needy artists and musicians, along with their families, while the Opry Convention Fund will go toward subsidizing record label activities during the convention. Pre-registration forms can be secured from the Opry Trust Fund, P. O. Box 100, Nashville, Tennessee 37202. Badges and ticket books cannot be mailed. They will be held for arrival in Nashville at the Municipal Auditorium after 12:00 Noon, Wednesday, Oct. 13th.

The tentative agenda of events has been set to begin on Oct. 9-10 with the Music City Pro-Celebrity Golf Tournament. The following events are covered by official registration

ticket:

Oct. 13: Earlybird Bluegrass Concert (7:30 PM, Opry House)

Oct. 14: WSW Luncheon & Spectacular (11:30 AM, Municipal Auditorium); CMA International Country Music Show (3:30 PM, M. A.); United Artists Show (9:00 PM, M. A.)

Oct. 15: Dot Records Luncheon & Show (1:00 PM, M. A.); Decca Party & Show (5:00 PM, M. A. Lower Level); CMA Dinner & Show (6:30 PM, M.A. with special ticket); Friday Night Opry (7:30 PM, O. H.)

Oct. 16: RCA Breakfast & Show (8:00 AM, M. A.); Capitol Luncheon & Show (12:00 Noon, M. A.); Columbia Party & Show (5:00 PM, M. A.); Grand Ole Opry (9:30 PM, O.H.); Atlas Artist Dance (10:00 PM).

Several additional events will be held on an invitation-only basis and are not covered by registration tickets. These include: The Kraft-CMA Music Awards Show (Oct. 10, live from Opry House); Hermitage Hotel Fan Club Dinner & Show (Oct. 11, 7 PM); The BMI Awards Dinner (Oct. 12, Belle Meade Country Club); The ASCAP Awards Dinner (Oct. 13, Hillwood Country Club); CMA Meeting (Oct. 14, 10 AM, M. A. Lower Level); SESAC Awards Dinner, (Oct. 14, 10 AM, Woodmont Country Club) and The Artist-Broadcaster Tape Session (Oct. 15, 9 AM, M. A.).

NBC's "Tuesday" To Spotlight Ott

NASHVILLE — Paul Ott, a Mississippi singer, will introduce his first release on NBC-TV's First Tuesday program, Sept. 7th. The song "The Soldier's Prayer," is on the Nashville-based Show Biz label and is the initial record to be released under a recent agreement that makes Mega Records exclusive distributor for Show Biz product.

Mega president, Brad McCuen, described Paul Ott as "a unique voice and personality" and "The Soldier's Prayer" as something completely different. NBC Executive producer Eliot Frankel revamped the First Tuesday program to include a special segment of "The Soldier's Prayer". Two network camera crews were put to work simultaneously: one in Vietnam, the other in Monument Studios in Nashville where they filmed the Paul Ott recording session. Award winning Tommy Tomizawa was the network's producer for the Nashville shooting.

Two of the nation's top disk jockeys played an important role in the discovery of Paul Ott. T. Tommy Cutrere known for his nationally syndicated radio show, "Music City, U.S.A." brought Paul to the attention of Show Biz record executives. Ralph Emery, whose own daily show is now in major markets from coast to coast heard Paul Ott's first session and told the Mega people about him.

Dirt Band's Rock Gets Down To Nitty Gritty

NASHVILLE — The Nitty Gritty Dirt Band recently recorded at Woodland Studios with many of Nashville's more noted country singers and musicians such as Roy Acuff, Jimmy Martin, Mother Maybelle Carter, Earl Scruggs, Merle Travis and Doc Watson.

The United Artists album recorded by the group will be released in October as a two-disk set.

CMA Calls For Rodgers Support

NASHVILLE — A campaign is underway for the issuance of a Jimmie Rodgers commemorative stamp and the Country Music Association has called for the support of the entire music community to make this a reality. The Citizens Stamp Advisory Committee will meet the end of September to review over 4,000 proposals, and can act favorably on only 20. Letters endorsing the project could be the determining factor in the "Father of Country Music" being so honored.

The following resolution has been adopted by the Country Music Association and sent to the Advisory Committee:

Whereas, Jimmie Rodgers is generally known as the Father of Country Music and is one of its greatest Pioneers; and whereas, 1972 marks the 75th anniversary of the birth of Jimmie Rodgers and the 45th anniversary of his first phonograph recording; and whereas, no recognition in the form of any honor on a nationwide basis has been afforded him; and whereas, Country Music organizations, record manufacturers and consumers feel strongly he should receive such honor; be it resolved, that the Country Music Association unanimously lends its support to a proposed commemorative stamp honoring Jimmie Rodgers.

No country music performer has been so honored. Letters supporting the proposal should be sent to the Advisory Committee and individual Senators and Congressmen immediately. The address for the committee is: Citizens Stamp Advisory Committee, c/o U. S. Postal Service, Washington, D. C. 20460.

Top Country Albums



Country LP Reviews

A lowdown, rotten heel makes good.



Hank Thompson's story about "The Mark Of A Heel" follows his smash hit, "Next Time I Fall In Love (I Won't)"

Hank Thompson's "The Mark Of A Heel"

DOA 17385
b/w "Promise Her Anything"



- 1 **RUBY**
Buck Owens & The Buckaroos (Capitol ST 795) 1
- 2 **I'M JUST ME**
Charley Pride (RCA LSP 4560) 2
- 3 **THE SENSATIONAL SONNY JAMES**
(Capitol ST 804) 3
- 4 **YOU'RE MY MAN**
Lynn Anderson (Columbia C 30793) 5
- 5 **THE BEST OF PORTER WAGONER & DOLLY PARTON**
(RCA LSP 4556) 7
- 6 **TOUCHING HOME**
Jerry Lee Lewis (Mercury SR 61343) 4
- 7 **THE LAST TIME I SAW HER**
Glen Campbell (Capitol SW 733) 10
- 8 **I WON'T MENTION IT AGAIN**
Ray Price (Columbia C 30510) 9
- 9 **MAN IN BLACK**
Johnny Cash (Columbia C 30550) 11
- 10 **SOMEDAY WE'LL LOOK BACK**
Merle Haggard & The Strangers (Capitol ST 335) 17
- 11 **THE INCREDIBLE ROY CLARK**
(Dot D0S 25990) 6
- 12 **SINGS LEAVIN' AND SAYIN' GOODBYE**
Faron Young (Mercury SR 61354) 15
- 13 **JEANNIE C. RILEY'S GREATEST HITS**
(Plantation PLP 13) 13
- 14 **WE SURE CAN LOVE EACH OTHER**
Tammy Wynette (Epic E 30658) 8
- 15 **I WANNA BE FREE**
Loretta Lynn (Decca DL 75282) 12
- 16 **I WONDER WHAT SHE'LL THINK ABOUT ME LEAVING**
Conway Twitty (Decca DL 75292) 20
- 17 **TAMMY'S GREATEST HITS VOL. II**
Tammy Wynette (Epic E 30733) 27
- 18 **ROSE GARDEN**
Lynn Anderson (Columbia C 30411) 15
- 19 **ONLY A WOMAN LIKE YOU**
Nat Stuckey (RCA LSP 4559) 19
- 20 **NEXT TIME I FALL IN LOVE (I WON'T)**
Hank Thompson (Dot D0S 25991) 18
- 21 **WHEN YOU'RE HOT YOU'RE HOT**
Jerry Reed (RCA LSP 4506) 14
- 22 **LONESOME**
Sammi Smith (Mega M 31) 22
- 23 **TOMMY OVERSTREET**
(Dot D0S 25992) 21
- 24 **A WOMAN ALWAYS KNOWS**
David Houston (Epic E 30657) 24
- 25 **DID YOU THINK TO PRAY**
Charley Pride (RCA 4513) 25
- 26 **HONKY TONKIN'**
Merle Haggard's Strangers (Capitol ST 795) 23
- 27 **HE'S SO FINE**
Jody Miller (Epic E 30659) —
- 28 **SOMETHING SPECIAL**
Jim Reeves (RCA LSP 4528) 26
- 29 **PICTURES OF MOMENTS TO REMEMBER**
Statler Bros. (Mercury SR 61349) —
- 30 **PITTY, PITTY, PATTY**
Susan Raye (Capitol ST 807) —

DAVID HOUSTON—Epic EG 30437

From the first tune on this two-record set, "The One Rose That's Left In My Heart," it's clear that David has control over his voice that few can match. This "twofer" specially priced reissue material boasts of "Loser's Cathedral" as well as his duet with Tammy Wynette, "My Elusive Dreams." Others included for drawing power run the gamut from Bobby Goldsboro's "Honey" to "King Of The Road." An economy package from a talent who gives each tune all he's got and then some is always a must-stock item. Chart action is assured.



JERRY KENNEDY PLAYS: WITH ALL DUE RESPECT TO KRIS KRISTOFFERSON—Mercury SR 61339

Since Jerry Kennedy has played such a major role in Kristofferson's rise to fame, waxing his tunes with Dave Dudley and other acts under his production umbrella, it is both fitting and proper that he should devote an all-Kris, all-instrumental LP to the writing genius. A programmer's delight, the 11 cuts here should fit the country and easy-listening markets perfectly; their gentleness and warmth fill a lone speaker or a whole country. Album should slide as smoothly up the charts as it lands on the ear.

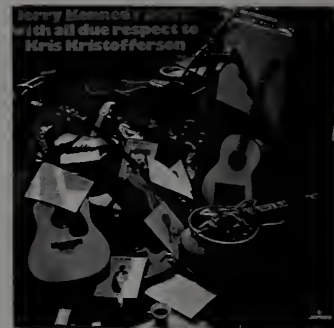

THIS IS JERRY WALLACE—Decca DL 75294

Jerry kind of came in country music's back door a few years back when he began to shed his MOR disguise. This package still shows why easy listening audiences often speak well of him, but the country feeling is what is most obvious. With "The Morning After" getting some strong regional action, this could be one of his best selling packages to date, featuring in addition, Joe South's "The Greatest Love" and Freddie Hart's "Hands Of The Man" for added programming appeal. His version of "New Orleans In The Rain" will also draw much favorable comment.



DIDN'T HE SHINE—Archie Campbell—RCA LSP 4582

Although primarily known now for his comic role on "Hee Haw," Archie is a gifted singer and arranger of gospel tunes. His last single, the title track is worth the price of an album all by itself—the finest religiously oriented song to come out of Nashville this year. The other nine tracks are all traditional, but Archie carefully updates them for the ear of today without sacrificing the old-time religious spirit. The Nashville Sounds are superb on back-up vocalizing on such tunes as "The Ninety And Nine" and "When Morning Comes." Not just a Sunday LP, it can be savored every day of the week. Buyer interest should be substantial.



JUST BECAUSE I'M NOT THE MAN I USED TO BE—Jim Richards—Princess PR 1115

Album is titled after his latest single release, but whatever he used to be, Jim is a fine country singer today. Standards such as "Four Walls" are well-handled as are those of more recent vintage: Kristofferson's "Sunday Morning Coming Down" and Buck Owens' "Together Again." High-point of the album however, is Jim's reading of Merle Kilgore's "Top Of This Town" which should be in for some considerable airplay. With proper exposure, LP could make a substantial chart dent as easy-going, old-styled country balladeers are always welcome.



BLUES COUNTRY STYLE—George Avak—K-Ark K-6030

George has been a top-billed attraction as a gun-shooter, but his musical career is still in the fledgling stages. On this, his second album for the label, he proves he can easily rank with guitarists and singers as well as the holster set. Many standards are included, given a fine reading by his pleasing vocal style: "Green, Green Grass of Home," "Shackles And Chains," "Help Me Make It Through The Night" and "Me And Bobby McGee." And he displays a fine country wit in "The Impersonator" and "The Next Time You Accuse Me." Airplay should start the sales action here, sure as shootin'.

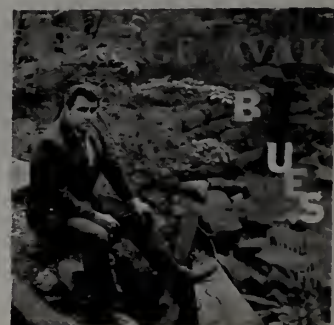

TOM T. HALL

SINGS

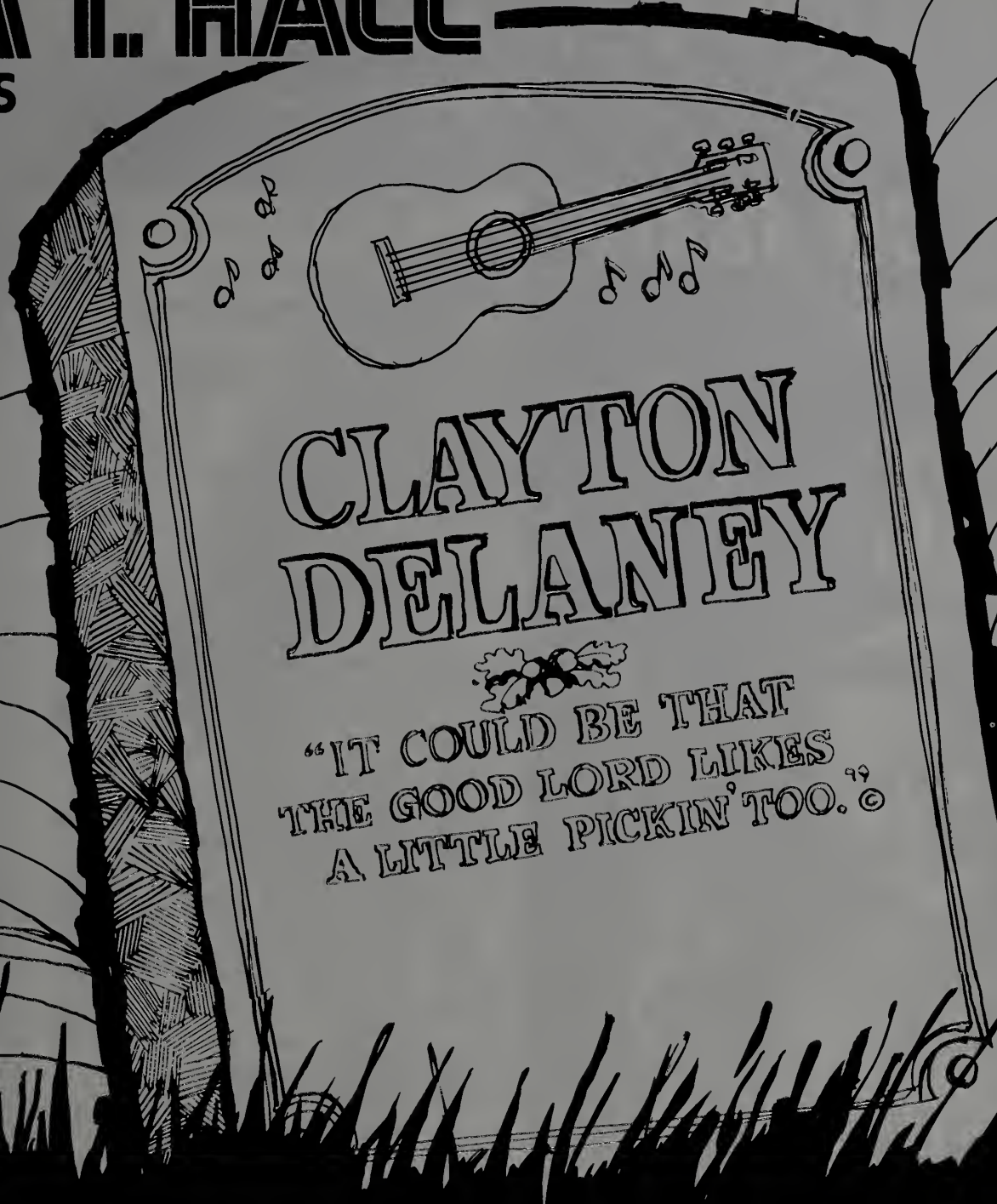

CLAYTON
DELANEY

“IT COULD BE THAT
THE GOOD LORD LIKES
A LITTLE PICKIN’ TOO.” ©

'The Year That Clayton Delaney Died'



Just Released Mercury SR61350
"In Search Of A Song."

Also available on musicassettes and Stereo 8 Tapes MCR-4-61350

Mercury 73221

exclusive representation:
the NEAL AGENCY LTD.
2325 Crestmor Road
Nashville, Tenn. 37215
(615) 385-0310

published by:
NEWKEYS MUSIC INC.
1531 Demonbreun
Nashville, Tenn. 37203
(615) 242-2461

TRANKS

D.J's
for helping make

'HERE I GO AGAIN'

the Hit of Bobby's
career!

DECCA 32839

Bobby Wright



Country Top 65

- | | | | | | |
|----|---|----|----|---|----|
| 1 | EASY LOVING
Freddie Hart (Capitol 3115)
(Blue Book—BMI) | 4 | 33 | I'M GONNA WRITE A SONG
Tommy Cash (Epic 10756)
(Flagship—BMI) | 29 |
| 2 | GOOD LOVIN' (MAKES IT RIGHT)
Tammy Wynette (Epic 10759)
(Algee—BMI) | 3 | 34 | LOVING HER WAS EASIER (THAN ANYTHING I'LL EVER DO AGAIN)
Roger Miller (Mercury 73230)
(Combine—BMI) | 43 |
| 3 | DREAM LOVER
Billy "Crash" Craddock (Cartwheel)
196 (Hudson Bay, Hill & Range
Screen Gems/Columbia—BMI) | 1 | 35 | LOSER'S COCKTAIL
Dick Curless (Capitol 3105)
(Champion—BMI) | 35 |
| 4 | THE YEAR THAT CLAYTON DELANEY DIED
Tom T. Hall (Mercury 73221)
(Newkeys—BMI) | 6 | 36 | NASHVILLE
David Houston (Epic 510748)
(Tree—BMI) | 30 |
| 5 | QUITS
Bill Anderson (Decca 32850)
(Stallion—BMI) | 8 | 37 | IT'S A SIN TO TELL A LIE
Slim Whitman (United Artists UA
50806) (Bregman, Vocco & Conn—ASCAP) | 42 |
| 6 | SOMEDAY WE'LL LOOK BACK
Merle Haggard (Capitol 3112)
(Blue Book—BMI) | 2 | 38 | PLEDGING MY LOVE
Kitty Wells (Decca 32840)
(Lion—BMI) | 36 |
| 7 | WHEN HE WALKS ON YOU
Jerry Lee Lewis (Mercury 73227)
(Blue Crest/Hill & Range—BMI) | 9 | 39 | HE'S SO FINE
Jody Miller (Epic 10734)
(Bright Tunes—BMI) | 34 |
| 8 | I'M JUST ME
Charlie Pride (RCA 9996)
(Tree—BMI) | 5 | 40 | COUNTRY GIRL WITH HOT PANTS ON
Leona Williams (Hickory 1606)
(Milene—ASCAP) | 44 |
| 9 | PITTY, PITTY, PATER
Susan Raye (Capitol 3129)
(Blue Book—BMI) | 11 | 41 | PICTURES
Statler Bros. (Mercury 73229)
(House of Cash—BMI) | 51 |
| 10 | YOU'RE LOOKING AT COUNTRY
Loretta Lynn (Decca 32851)
(Sure Fire—BMI) | 13 | 42 | BACK THEN
Wanda Jackson (Capitol 3143)
(Duchess—BMI) | 47 |
| 11 | GOOD ENOUGH TO BE YOUR WIFE
Jeannie C. Riley (Plantation 75)
(Belwin Mills—ASCAP) | 12 | 43 | BE A LITTLE QUIETER
Porter Wagoner (RCA 1007)
(Owepar—BMI) | 54 |
| 12 | I WONDER WHAT SHE'LL THINK ABOUT ME LEAVING
Conway Twitty (Decca 32842)
(Blue Book—BMI) | 7 | 44 | LOVE'S OLD SONG
Barbara Fairchild (Columbia 45422)
(Duchess—BMI) | 50 |
| 13 | MY BLUE TEARS
Dolly Parton (RCA 9999)
(Owepar—BMI) | 14 | 45 | THE CHOKIN' KIND
Diana Trask (Dot 17384)
(Wilderness—BMI) | 49 |
| 14 | HERE I GO AGAIN
Bobby Wright (Decca 32839)
(Contention—SESAC) | 17 | 46 | NO NEED TO WORRY
Johnny Cash & June Carter (Columbia
45431) (J. M. Henson—SESAC) | 57 |
| 15 | I'D RATHER BE SORRY
Ray Price (Columbia 45425)
(Buckhorn—BMI) | 19 | 47 | IF THIS IS OUR LAST TIME
Brenda Lee (Decca 32848)
(Blue Crest—BMI) | 53 |
| 16 | BRIGHT LIGHTS, BIG CITY
Sonny James (Capitol 3114)
(Conrad—BMI) | 10 | 48 | IF YOU THINK THAT IT'S ALL RIGHT
Johnny Carver (Epic 10760)
(Green Grass—BMI) | 52 |
| 17 | BRAND NEW MISTER ME
Mel Tillis & The Statesiders (MGM
14275) (Sawgrass—BMI) | 20 | 49 | AFTER ALL THEY USED TO BELONG TO ME
Hank Williams Jr. (MGM 14277)
(Hank Williams Jr.—BMI) | 59 |
| 18 | LEAVIN' AND SAYIN' GOODBYE
Faron Young (Mercury 73220)
(Tree—BMI) | 23 | 50 | FLY AWAY AGAIN
Dave Dudley (Mercury 73225)
(Addel—BMI) | 58 |
| 19 | THE MARK OF A HEEL
Hank Thompson (Dot 17385)
(Central—BMI) | 24 | 51 | THE NIGHT MISS NANCY ANN'S HOTEL FOR SINGLE GIRLS BURNED DOWN
Tex Williams (Monument 8503)
(House of Cash—BMI) | 60 |
| 20 | THE LAST TIME I SAW HER
Glen Campbell (Capitol 3123)
(Warner/Tamerlane—BMI) | 22 | 52 | SHE CRIED
Roy Clark (Dot 17386)
(Tree—BMI) | 55 |
| 21 | CEDARTOWN, GEORGIA
Waylon Jennings (RCA 1003)
(Tree—BMI) | 25 | 53 | PENCIL MARKS ON THE WALL
Henson Cargill (Mega 0030)
(Free Verse—ASCAP) | 45 |
| 22 | SATURDAY MORNING CONFUSION
Bobby Russell (United Artists 50788)
(Pix Russ—ASCAP) | 21 | 54 | THE MORNING AFTER
Jerry Wallace (Decca 32859)
(4 Star—BMI) | — |
| 23 | THE PHILADELPHIA FILLIES
Del Reeves (United Artists 50802)
(Milene—ASCAP) | 16 | 55 | IF I HAD YOU
Bobby Lewis (United Artists 50791)
(Passkey—BMI) | 56 |
| 24 | TREAT HIM RIGHT
Barbara Mandrell (Columbia 45391)
(Don Music—BMI) | 15 | 56 | CONGRATULATIONS (YOU SURE MADE A MAN OUT OF HIM)
Arlene Harden (Columbia 45420)
(Crosskeys—ASCAP) | 46 |
| 25 | HOW CAN I UNLOVE YOU
Lynn Anderson (Columbia 45429)
(Lowery—BMI) | 32 | 57 | I'M GONNA ACT RIGHT
Nat Stuckey (RCA 1010)
(Cedarwood—BMI) | — |
| 26 | THERE MUST BE MORE TO LIFE THAN GROWING OLD
Jack Blanchard & Misty Morgan
(Mega 0031) (Hall-Clement, Birdwalk
—BMI) | 28 | 58 | MR. & MRS. UNTRUE
Johnny Russell (RCA 1000)
(Pocketful of Tunes—BMI) | 61 |
| 27 | INDIAN LAKE
Freddie Weller (Columbia 45388)
(Pocketful of Tunes—BMI) | 18 | 59 | HONKY-TONK STARDUST COWBOY
Bill Rice (Capitol 3156)
(Jack & Bill—ASCAP) | — |
| 28 | ROLLIN' MY SWEET BABY'S ARMS
Buck Owens & The Buckaroos (Capitol
3146) (Blue Book—BMI) | 33 | 60 | I GOT A WOMAN
Bob Luman (Epic 10755)
(Hill & Range—BMI) | 48 |
| 29 | ONE NIGHT OF LOVE
Johnny Duncan (Columbia 45418)
(Pi-Gem—BMI) | 31 | 61 | SLEEP WALK
Strangers (Capitol 3144)
(Hudson Bay—BMI) | 64 |
| 30 | I DON'T KNOW YOU (ANYMORE)
Tommy Overstreet (Dot 17387)
(Shenandoah, Terrace—ASCAP) | 41 | 62 | I WILL DRINK YOUR WINE
Buddy Alan (Capitol 3146)
(Blue Book—BMI) | 62 |
| 31 | THE RIGHT COMBINATION
Porter Wagoner & Dolly Parton
(RCA 9994) (Owepar—BMI) | 26 | 63 | HANGING OVER ME
Jack Greene (Decca 32863)
(Tree—BMI) | — |
| 32 | DON'T LET HIM MAKE A MEMORY OUT OF ME
Billy Walker (MGM 14268)
(Hill & Range SPR—BMI) | 27 | 64 | SOMEONE STEPPED IN
Webb Pierce (Decca 32855)
(Brandywine—ASCAP) | — |
| | | | 65 | OPEN UP THE BOOK (AND TAKE A LOOK)
Ferlin Husky (Capitol 3165)
(Lowery—BMI) | — |

Thanks to all our friends...

The D.J.'s, Distributors, One Stops, Racks, and Juke Box Operators . . . for making

"DREAM LOVER"

Our Second #1 Record



"DREAM LOVER" #196

Billy "CRASH" Craddock

PRODUCED BY RON CHANCEY

Cartwheel Records Inc.



1204 16th Ave., So. Nashville, Tenn.

Phone: 615-385-0840

Freddie Hart has had his share of good and bad.

He dropped out of school at age seven.

He hit the road when he was nine.

He joined the Marines at thirteen.

Music has always been a part of Freddie.

He played cigar-box guitar at age five.

He wrote songs at age six.

He met Hank Williams in 1949.

He first recorded in 1952.

"Easy Loving" hit in 1971.

EASY LOVING.
Freddie Hart's new
Capitol album. (ST-838).

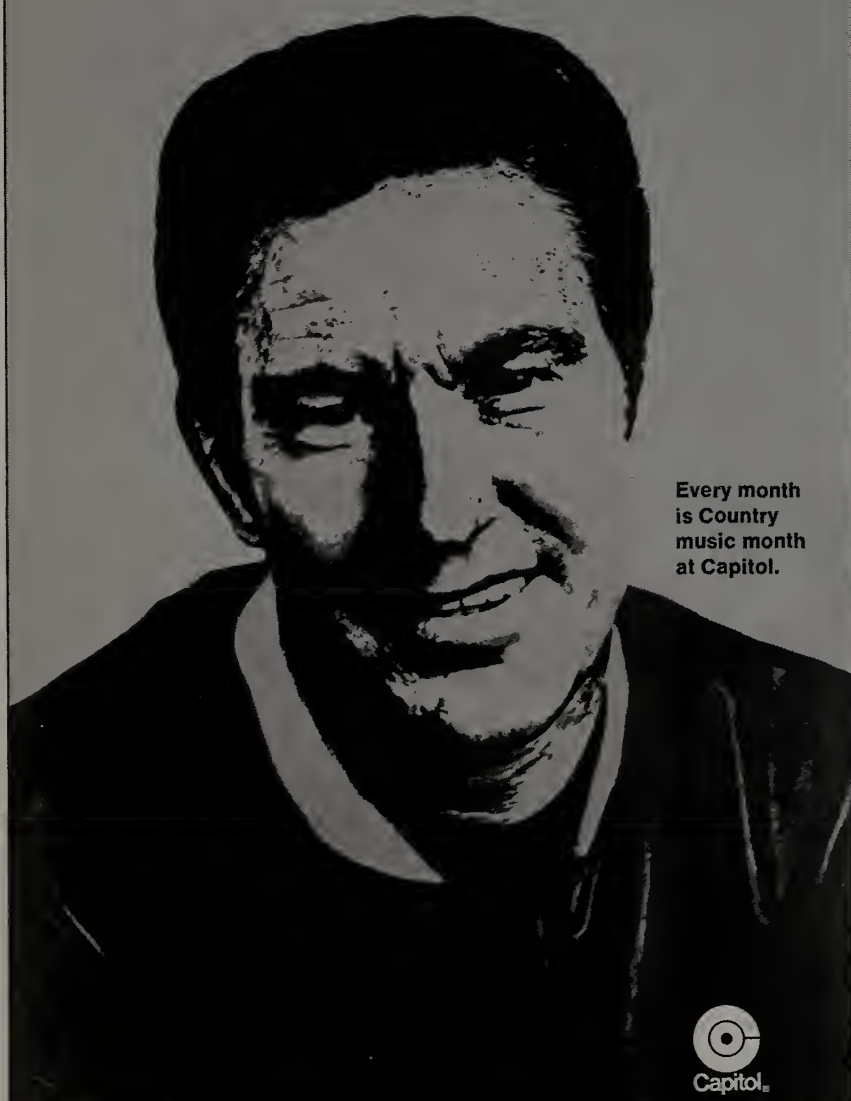

Every month
is Country
music month
at Capitol.



Eddy Arnold Hosts "Sound" TV Special

NEW YORK — Jerry Purcell, Eddy Arnold's personal manager has announced that the singer will host and star in a syndicated TV special to be viewed in 76 outlets, "Sound America." The hour-long program will be aired on each station in prime time during the two-week period beginning Sunday, Sept. 19th.

Co-starring with Arnold in the special are John Davidson, Roy Clark, Alex Dreier, Candi Staton, Marty Robbins and Sammi Smith.

A presentation of 21st Century Productions of Nashville, "Sound America" will be aired in New York City by WNEW-TV on Sunday, Sept. 26th at 9 P.M. as well as on KTLA, Los Angeles, WGN, Chicago, WPVI, Philadelphia, WHDH, Boston, KRON, San Francisco, and WJBK, Detroit, at various dates and times.

In addition to acting as host, Arnold will open the show with a medley of his top hits, including "Cotton Fields," "Gentle On My Mind," "Cattle Call" and "My Sweet Lord." His version of "Welcome To My World," newly-released by RCA, also will be featured. Roy Clark will play his guitar versions of "Twelfth Street Rag" and "You Gotta Love People." Marty Robbins' "My Woman, My Woman, My Wife" and Sammi Smith's "Help Me Make It Through the Night," both million record sellers, will also highlight the hour.

Owens' Ranch Adds New TV Markets

BAKERSFIELD — Buck Owens Enterprises recently announced that the current color TV season of "The Buck Owens Ranch Show" will now be aired weekly over the American Forces Radio's six circuits, on 47 participating stations for the benefit of American servicemen and their families.

The show has also added the Tulsa, Oklahoma and Lancaster-York, Pa. markets to their syndication network, bringing the total outlets to 70.

Williams New Epic Nash. Sales Chief

NASHVILLE — Bill Williams was recently named to the post of national sales and promotion for Epic and Columbia custom labels here. Born in Texas, (in the same town where Hank Thompson started out), his father owned a retail record store and first interested him in the music business.

According to Williams, country music has maintained its popularity because it reflects the back to earth naturalness of both the producer and artist. Kids are no longer classifying music today, he added, and that has increased its potential audience without drastically changing its characteristics.

Award-Winning Haynes & KLAC Re-Sign Pact

HOLLYWOOD — Dick Haynes has been signed to return to LA's KLAC, according to Bruce Johnson, vp and general manager of the Metromedia station. Haynes had previously worked at Long Beach's KFOX, but for ten years previous to that association was morning radio's top-rated host for the LA station and was awarded the 1969 award as top air personality by the Academy of Country & Western Music.

KLAC was itself recently honored as Radio Station of the Year by the C&W Academy. Program director Bill Ward is a past Academy president and is presently serving as the assistant treasurer for the Country Music Association.

Sanders Back On TV, Disk Scene

HOLLYWOOD — Ray Sanders who will return to TV as a regular on "Hee-Haw" when its new season begins on Sept. 18th has released a new single for UA, "All I Ever Need Is You," according to Libra Productions. Ray is currently touring in the California area.



HOUSTON PRESENTS JAPAN—Shoji Tabuchi, born in Daishoji, Japan, recently made a guest appearance at the Grand Ole Opry with David Houston where he received standing ovations when he fiddled his version of "Orange Blossom Special" and "Boil Them Cabbage Down." Shoji is slated to make his first major recording in the near future. He has just signed a personal management contract with Tillman Franks and will be appearing with David Houston on the David Houston Show which is booked by Hubert Long Agency of Nashville, Tennessee. In the words of a Texan at Panther Hall upon seeing Shoji play "Black Mountain Rag," "He is the only person I ever saw that could play a violin and a fiddle at the same time."



Picks of the Week

MARTY ROBBINS (Columbia 45442)

Early Morning Sunshine (2:43) (Mariposa Music, BMI—J. Marshall)

Culled from his "Today" LP, the follow-up to "The Chair" should sit well with his loyal public. A melody line that takes over should make this one of Marty's biggest ever, and future pop action is also a factor here. Flip no info. available.

DAVID HOUSTON (Epic 10778)

Home Sweet Home (2:35) (Algee Music, BMI—B. Sherrill, L. Butler)

Mid-tempo stay-at-home ballad that Houston virtually caresses. Should follow easily in the footsteps of "Nashville" as another hit, sweet hit for David. Flip: no info. available.

JIMMY DICKENS (UA 50834)

You Only Want Me For My Body (2:32) (Tree, BMI—B. Braddock)

With his strongest material since "Bird of Paradise," this one's going to move like the Dickens for him. Humor which improves with each listen and a Biff Collie production that's serious where it ought to be. Flip: "What Will I Do Then" (2:47) (Tree, BMI—R. Lane, B. Eustis)

DICK CURLESS (Capitol 6299)

Snap Your Fingers (2:45) (Fred Rose Music, BMI—A. Zanetis, G. Martin)

The man doing so well now with "Loser's Cocktail" treats this one to a nitecap. Over the years, this song has been recorded innumerable times, but Dick's phrasing is so perfect, it sounds like a new tune. Flip: "Bully Of The Town" (2:17) (Southern Music, ASCAP—F. Lane)

JACK RENO (Target 137)

Hitchin' A Ride (2:20) (Intune, BMI—Murray, Callander)

Last year's pop hit for Vanity Fair comes into its own in the country air as Jack Reno delivers his most commercial outing in years. Solid programming material. Flip: "You Are My Destiny" (1:51) (Golden Arrow Music, BMI—J. Reno)

NORMA JEAN (RCA 1016)

Chicken Every Sunday (2:22) (Cedarwood, BMI—C. & B. Craig)

Up-tempo tune about the relative definition of being "poor" should put Norma back on the charts in short order. Fine back-up by the Jordanaires. Flip: "Heavenly" (2:39) (Freeway, BMI—Ball, Stone, Roberts)

CARL BELEW & BETTY JEAN ROBINSON (Decca 32871)

Living Under Pressure (2:46) (Four Most Music, BMI—B. Knight)

Lyrics really hit home here, but the fine vocal duet which makes the strength stronger deserves as much of the credit. Airplay should pressurize it for a high spot on the charts. Flip: "Hung Up On Lovin' You" (3:13) (4 Star Music, BMI—B. J. Robinson)

Best Bets

BECKI BLUEFIELD (Prize 98-16)

Saturday Town (2:42) (Gaylo Music, BMI—B. Bluefield, R. Nokes) If Nancy Sinatra had decided to be a country singer, she probably would have sounded like this. Fine treatment of self-penned ballad should start things rolling for this talented gal. Flip: "After A Great Day" (2:14) (Dunbar Music, BMI—B. Bluefield)

BOBBY LEE TRAMMELL (Souncot 1119)

Let's Wash The World And Make It Clean (2:15) (4 Star Music, BMI—B. J. Robinson) Tune is a bouncy message number with a Tex-Mex touch to highlight the country flavor. Sounds like good programming bet for many markets. Flip: "My Shoes Keep Walking Back To You" (2:35) (Copar Music, BMI—Ross, Wills)

JOHN L. SULLIVAN (Shue 1975)

A Little Piece At A Time (2:47) (Cent. Songs, BMI—S. Hall, N. Merritt) Lush and lovely country ballad, the kind Ray Price is so good at. Sullivan delivers the message with just the right touch of sadness; Disk is a potent programming and potential sales item. Flip: "Snap Your Fingers" (2:45) (Fred Rose Music, BMI—G. Martin, A. Zinetis)

JERRY SMITH (Decca 32869)

Gear Jammer (2:20) (Papa Joe's Music, ASCAP—J. Smith) The "Toy Piano" man really doesn't play around. He bangs that piano for all it's worth and pounds out some fine instrumental change of pace programming here. Funky, to say the least. Flip: "The Touch Of Love" (2:36) (same credits)

MAYF NUTTER (Capitol 3181)

Never Ending Song Of Love (2:36) (Metric Music, BMI—D. Bramlett) Newest talent in the Buck Owens stable gently funks through this Delaney & Bonnie pop hit. Chart success is strong possibility for the songwriter and actor. Flip: "Okla." (Blue Book Music, BMI—M. Nutter)

D'LYNN & LA DONA CRIST (Souncot 1120)

Send Me The Pillow That You Dream On (2:41) (4 Star Music, BMI—H. Locklin) Beautiful treatment of Hank Locklin standard should be in for airplay in many markets and a possible chart slot. Flip: "Bobby McNamara" (2:41) (4 Star Music, BMI—B. J. Robinson)

NEAL HART (Stoneway 1049)

The First To Go To Sleep (2:12) (Raydee Music, SESAC—E. Noack) As sleep-talking songs go, this is a riser. Hart's convincing and the tune could do things with radio play. Flip: "I'm Hard As A Rock" (2:22) (Glad Music, BMI—E. Montgomery)

MURRAY LEWIS (Cristy 1033)

No One Cares (2:15) (Tocino Music, BMI—B. Bishop) Strong lyric line about loneliness gets to the heart of the matter and could be the chief reason for airplay here. Flip: "What Happened" (1:53) (Tocino Music, BMI—B. Bercier)

THE MOODS (Prize 98-17)

Red Red Wine (1:55) (Tallyrand, BMI—N. Diamond) Happy-sounding treatment of a Neil Diamond pop hit with more than a hint of that old rockabilly sound in the chorus. Chart contender. Flip: "Where Was I (When I Needed Me)" (2:05) (Gaylene Music, ASCAP—J. Cowen)

Doug Kershaw says, "Worrying, to me, is when you're not concerned enough to do something about it" . . . Decca artist Brenda Lee will set off a concentrated round of Fall p.a.'s with her Aug. 26th-Sept. 9th engagement at the Fremont Hotel in Las Vegas. Other dates set by IFA on the artist include: Sept. 16-18, Western Fair, London, Canada; Oct. 1-10, Holiday House, Pittsburgh, Penna.; Oct. 18-23, Elmwood Casino, Windsor, Ontario, Canada; Oct. 29-Nov. 6, The LaFiesta, Juarez, Mexico . . . The House of Bryant reports two new releases out that are getting great play: "Muddy Bottom" by the Osborne Brothers on Decca and "Fall Away" by Tex Ritter on Capitol.

Ronnie Dove, Decca artist, whose current single is the country oriented "Just The Other Side Of Nowhere," penned by Kristofferson, c/w the Harlan Howard perennial, "If I Cried," made his first appearance on the Grand Ole Opry recently to an enthusiastic audience. Dove, long-time favorite with pop fans was elated at the chance to do his thing for the Opry fans, but his effort to give them his finest performance resulted in a need for surgery. He recently entered Baptist Hospital and was treated by Music City's well-known surgeon, Dr. Elkin Rippey. . . . Johnny Paycheck's soon to be first release on Epic Records is a Freddie North penned tune titled "She's All I Got". Billy Sherrill produced the session . . . Vicky Starr, now appearing in N.Y. area spots, hushes the crowd by dropping a folk-air from her native Scotland into her set.

Oslo, Stockholm, Copenhagen, Glasgow, Manchester, London, and Birmingham are the cities that will be included in the Johnny Cash overseas tour Sept. 9-20. Prior to departure, John recorded a commercial for Chrysler/Plymouth; he should be very knowledgeable on the subject as his brother, Roy Cash, has been an executive with a Memphis branch of the company for 23 years. Johnny's first session produced by Larry Butler has been recorded, with an early date for release set . . . "Harper Valley's" Jeannie C. Riley recently recorded her first session under the direction of MGM's Jim Vienneau . . . Decca recording artist Jeanne Pruett has signed an exclusive writer's contract with Moss Rose Publications, Inc. Jeanne's current Decca release is, "Hold To My Unchanging Love."

Freddy Weller recently winged his way to Toronto where he rejoined his rock group, The Raiders, for an appearance on the Kenny Rogers syndicated TV show which will be aired in some 120 American markets this fall. Wearing his rock 'n roll hat, Weller joined the Raiders to do their new single "Birds Of A Feather." Freddy then pinned a country star on his chest and sang his new solo single "Another Night of Love," and joined Kenny Rogers for a down-home version of the John D. Loudermilk classic, "Break My Mind" . . . Country cookin' with the Lowery tune, "Open Up The Book", is Capitol artist Ferlin Husky . . . Coming up with a country instrumental version of the Joe South penned "How Can I Unlove You" is top Nashville sideman Charlie McCoy.

George Kent's new release on Rice is entitled "Falling Apart" penned by Bobby Bare and Billy Joe Shaver . . . Bud Logan has just completed a session for Rice Records. Release is scheduled for the first week in September . . . Jack Ward was in Music City recently to record. He's looking for a follow-up to his Starday recording of "Treat Her Right" and it looks like he's got it . . . Hoover has accepted Tompall and the Glaser Brothers' offer to produce several of his own songs for their forthcoming MGM LP. This will be the first time the already diversified singer-songwriter has tried his hand at producing . . . Congratulations to Johnny K, now on station WENO for his

16 years as a D.J. Charlie Williams is now music director at KFOX, Long Beach . . . Don Howser, one of the real heavyweights in Nashville radio, has returned to WENO Radio after a two year absence. Howser takes over the morning drive shift 6 to 10 A.M. His is the commercial voice of the Porter Waggoner TV Show.

Leon Ashley and Margie Singleton are inviting all country music fans to visit them at Laura's House, which is a new seafood restaurant that recently opened in Nashville . . . RCA recording artist Nat Stuckey winds up his busiest summer in years with a late September tour through the great Northwest. The trip will include a visit by Stuckey and his band, The Sweet Thangs, to the Elmendorf Air Force Base in Anchorage, Alaska . . . Tom T. Hall, whose single of "The Year That Clayton Delaney Died", is occupying the tops of national country charts throughout the nation and rapidly climbing the pop charts, is going to grant his record listening public the chance to name his band group. Further details on the upcoming contest will be announced shortly.

Dale Ward, Dot Records' artist whose current single, "Brand New Me" is finding its way to the pick and play list on country stations across the nation, has been signed to star in his own syndicated TV show. The first three segments of "The Dale Ward Show" were taped this week in Oklahoma City and included guestings by Henson Cargill, Johnny Darrell and Wanda Conklin. Based on the current marketing of the show, it has the potential viewing audience of 70 million, according to Ward's personal manager, Carl Friend . . . Mrs. Austin Woods has presented her late husband's guitar to the Country Music Hall of Fame. Mr. Woods was a Country Music Booster in the Lake of the Ozarks, and the guitar will be displayed in the Country Hall of Fame and Museum . . . Brenda Lee, during the past few months, has become more deeply involved in a facet of her talent yet too seldom seen: writing. During a recent trip to New York for appearances, initial discussions were held regarding the publication of her first book of poetry, currently nearing completion. Brenda is also working on material for a future album release to be made up entirely of self-penned songs. A subsequent single release written by Brenda is also planned.

On behalf of CMA, Johnny Cash has requested proclamations declaring October as Country Music Month from the Governors of the 50 states. Official documents from the following states have been received: Alaska, Arkansas, Indiana, Kentucky, Mississippi, Montana, New Jersey, North Dakota, South Dakota, Texas, Vermont, Virginia, and Wyoming. The committee is hopeful that President Nixon will again proclaim October Country Music Month for the nation . . . Bobby Bare's new release for Mercury is "Short and Sweet" . . . Buck Owens Enterprises has very happily announced that WTUV in Tupelo, Mississippi and WHIO in Dayton, Ohio will be carrying the Buck Owens Ranch Show starting this Fall.

SUPER PROMOTIONS IS BRITE-STAR

Complete record promotion and distribution Services, 728 16th Ave. S. Nashville, Tenn. 37203

(615) 244-4064

30 Countries To Attend A&M's International Meet

HOLLYWOOD — A&M Records annual meeting of international affiliates will be held this week (8-10) in Los Angeles. David Hubert, international director for A&M, noted that more than 30 countries will participate in the three day meet, which will be themed "Listen To Your World." This motif will be carried out through graphics and decor which will be set up on the A&M soundstage.

The purpose of the meeting, says Hubert, "is to present our new artists and new product to our affiliates; to afford a sharing of packaging and promotion ideas among all affiliates; to orient affiliates with the latest developments in A&M's creative, sales and promotion activities here in the U.S."

Highlighting the meetings will be special presentations by Jerry Moss, Bob Fead, Lou Adler, Bob Elliott, Chuck Kaye, Gil Friesen and Bob Garcia. Clarence Avant will present new artists and product from his Sussex line; Larry Yaskiel, A&M's Euro-

pean Director, John Deacon from A&M's England operation, and Gerry Lacoursiere, from A&M-Canada will present new A&M acts and promotion plans.

Highlights will also include a special 20 minute promo film by Chuck Braverman representing approximately forty A&M artists. The film is constructed from a combination of existing stills, location shots at local/record stores and 3 or 4 artists at work in the recording studio.

Lou Adler, president of Ode Records, will also present a special video tape featuring Ode artists Carole King, David T. Walker, and Merry Clayton and A&M's Billy Preston. An evening of musical entertainment featuring the talents of A&M's Carpenters and new artists has also been arranged.

International representatives planning to attend include: Ramon Villanueva, Argentina; Allan Hely and Phil Mathews, Australia; D. Winston Leach, Barbados; Mariozinho Rocha, Brazil; Gerry Lacoursiere, Canada; Guillermo Diez R., Colombia; Mike Von Winterfeldt, Far East; and Larry Yaskiel and John Deacon, England.

Also Colin Hadley, England; Miss Luce Stalenq, France; Monti Lueftner and George Naschke, Germany; Jan Van Schalkwijk and Robert van Beek, Holland, Belgium and Luxembourg; and Luigi Mantovani, Italy.

Also Minoru Suzuki and Hirokazu Aihara, Japan; Ivan Nordstroem, Denmark, Norway and Sweden; Fernando Montilla, Puerto Rico; Luis Calvo, Spain; and Ernesto Aue, Venezuela.



DEMAI, HUBERT, MOSS

Capitol Jazz Re-Issues To Be Mkted By Bovema, Confab Hears

AMSTERDAM — A release of 15 albums of Capitol Jazz Classics was a highlight item at Bovema's annual sales convention held in Haarlem on Aug. 27. Compiled by Capitol label manager Joop Visser and Dutch jazz expert Simon Korteweg, the series contains not only re-mastered albums by jazz giants Art Tatum, Gerry Mulligan, Duke Ellington, Woody Herman, Benny Goodman, Dizzy Gillespie, and Serge Chalof but also some never previously issued material by, among others, Stan Kenton. Furthermore, the completed "Birth of the Cool" from Miles Davis with the extra number "Darn that Dream," which was originally meant to be included, and "Hollywood Stampede," with Coleman Hawkins recorded in Hawk's most creative period (January/February 1945).

Theo Roos, head of Bovema's International Division, revealed that "the series will be marketed throughout Europe and nearly all the European EMI companies have shown tremendous interest in this series, thus boosting Capitol's European sales."

Bovema is becoming more and more international. The 'Best of' series, which was started one and a half years ago, has a complement of 80 albums. At the convention three new internationally flavoured series were announced. Besides the Capitol Jazz Classics, a new series, A Portrait Of was launched including new couplings by such names as Louis Armstrong, Stevie Wonder, Shirley Bassey, Ray Charles, Frank Sinatra, Steppenwolf,

Jimmie Smith, Nat King Cole, Canned Heat, Dean Martin and many others, sets are luxuriously packaged and have special sleeves which include a full color removable photograph of the artist concerned. For the first time, classical items are also included in a popular series with Portraits of, among others, Herbert Von Karajan, Yehudi Menuhin, and Victoria De Los Angeles with new items from the Portrait series to be released monthly. The third series is a medium price Story Of series, with couplings by such famous names as the Andrews Sisters, Paul Robeson, Roy Orbison, Beach Boys, George Shearing and others.

The three series are merchandised with extra special campaigns for dealers and customers who can both win package holidays to different countries. Mobiles, posters, folders, window displays are also used.

New Dutch top product launched at the convention came from Dutch pop groups the Cats, Clover Leaf and a new progressive group Solution. To be able to give each item from its catalog sufficient attention, Bovema's A&R repertoire departments are being reorganized with separate sales and promotion forces for international and national product. Joop Visser is heading the international repertoire section and is concentrating on the large number of labels Bovema represents.

Martin Kleinjan is now in charge of national product in order to boost Bovema's percentage in the Dutch market.

Carlin's Rich In U.S. For Deals

LONDON — Following his recent promotion to vice president of Carlin and Carbert Music Inc., Paul Rich has left for a three month visit to the United States.

Main purpose of visit is consistent with the newly opened American office—Carbert Music Inc—and the setting up world wide of Carbert's representation. Carbert has already acquired from Commonwealth United the T.M. catalog as well as the Faithful Virtue and Chardon copyrights now known as Hudson Bay Music; Quintet Music and U.S. Songs. In line with the expansion policies of Carlin and Carbert Music and Freddy Bienstock's heavy involvement in further important acquisitions, Rich will now work in the areas hitherto covered by Bienstock in negotiating further ca-

talog deals and will also be meeting up with executives of current Carlin representations. Of course he will also continue to function similarly at the London office in connection with further world wide representations with important writer/artists in the U.K.

Rich, general Professional Manager of Carlin for the past four years, was instrumental in the signing of many important writers and writer/artists to the company and helped build one of the most formidable promotion teams on the British music scene. Rich together with Bienstock will attend the closing night of Elvis Presley's current season in Las Vegas thence to New York, where Rich will be based at the Cabert offices at 1619 Broadway.

International Artist Of The Week: MAC & KATIE KISSOON



While Middle of the Road scored in Europe with their version of "Chirpy Chirpy Cheep Cheep," it's Mac and Katie Kissoon who have hit the charts in America with version of the hitbound song. In 1967, Katie sang with the Rag Dolls and made the charts both sides of the Atlantic, while her brother Mac was singing with the Marionettes backing many leading artists on record and TV. Mac came to England in 1969 and signed a contract with Miki Dallon's Young Blood label. His first record with the label, "Get Down With It/Satisfaction," met with instant success on the R&B charts. Then the two joined forces and made a big impact on the international music scene with their single, "Chirpy Chirpy Cheep Cheep." They have a new single out called "Pigeon," and an album, "Soul Satisfaction."



Great Britain

In a surprise move, Olav Wyper exited his post as RCA Records commercial manager on August 28th to join the Essex Music group as creative director and member of the board. Wyper had been with RCA for ten months following the appointment of his old CBS chief Ken Glancy as managing director of the UK record division of RCA. During the interim period between his CBS days and joining RCA, Wyper was at Philips, where he played a major role in launching that company's progressive Vertigo label. He repeated a similar process at RCA with the Neon series, and now joins Essex, whose Fly label of predominantly progressive material is currently scoring heavily in the charts. Glancy commented that "another episode in the odyssey of Olav Wyper has closed and a new one is about to begin. Once again, and as always, I wish him well. His contribution to our progress this past year has been enormously significant." Wyper will not be replaced, but marketing manager Geoff Hannington and popular A&R manager Mike Everett will now report direct to Glancy, as will press officer Rodney Burbeck who has been redesignated public affairs manager. It is understood that Wyper's duties at Essex will include co-ordinating record production on a worldwide basis, the future development of the Fly label, and possible new projects of a much wider scope in the leisure industry.

A British Kinney contingent of managing director Ian Ralfini, marketing manager Phil Carson, publicity and promotion manager Des Brown and European director Clive Selwood attended a recent meeting in Amsterdam to co-ordinate major European promotion and marketing plans for Kinney group product. Also present were Bernard de Bosson and Siegfried Loch, respectively Kinney managing directors in France and Germany, and members of their staffs. Amongst items on the agenda were joint promotion of European tours by Kinney artists, the pooling of point of sale material for availability in all three countries and poster printing in uniform Continental sizes. Promotion costs such as Radio Luxembourg's various language services will be shared, and simultaneous releases will be planned in the three territories.

New hand at the helm of Screen Gems Columbia Music, vacant since the departure of Jack Magraw and Terry Oates, will be Ray Walter, who left his post as Carlin Music general professional manager at the end of last month. His new post was announced by Screen Gems Columbia president Lester Sills here, and he will work out of the company's present premises in Wells Street. Walter has previous overseas music publishing experience in Australia and South Africa, where he worked on the Screen Gems catalog. He is succeeded at Carlin by Malcolm Forrester, who headed the music publishing arm of the now defunct Immediate Records enterprise and has latterly been running his own Getaway Music company which is administered by Carlin. Forrester will also supervise Carlin's CMC recording offshoot whose product is released here through EMI.

Anthony Edwards and John Coletta, managers of Deep Purple and Ashton, Gardner, Dyke and Co., are launching their own Purple label on October 1st with the release of four albums. Purple will be released throughout the world by EMI under a three-year licensing deal with the exception of the States and Canada, where no outlet has been finalised yet. Initial releases are "Curtiss Maldon" by the duo of the same name, "A Drop In The Ocean" by American-born Buddy Bohn, "Pick Up A Bone"

by Rupert Hine and David MacIver, and "Gemini Suite" by Jon Lord. The latter work was commissioned originally by the BBC, and the LP features Lord with the London Symphony Orchestra conducted by Malcolm Arnold with solo contributions from Albert Lee, Roger Glover, Ian Paice, Tony Ashton and Yvonne Elliman. A forthcoming Purple act is Bullet comprising former Atomic Rooster members John Cann and Paul Hammond, ex-Quatermass man Johnny Gustafson, and a Liverpool musician Al Shaw. Another possible Purple pactee is West Coast guitarist Carole Hunter.

Two veteran American jazzmen are set for London concerts this fall through Robert Paterson's International Entertainment Ltd. Benny Goodman will star at the Royal Albert Hall on October 2nd, preceded by a concert at the Brighton Dome Theatre on September 30th. Goodman was originally scheduled for a London appearance back in April, but had to cancel it following a back injury sustained in a fall during the earlier part of his European spring tour. Duke Ellington will appear at London's Hammersmith Odeon on October 21st as part of a short British tour following his five-week State Department swing through Russia. His UK provincial concerts will be in Southport, Bournemouth, Bristol, Nottingham and Birmingham. Ellington will lead his own orchestra, and Goodman will front a British band specially picked for the occasion.

The movie-making artist management Hemdale group has acquired a £1,750,000 controlling stake in Constellation Investments, which owns the services of stars such as Cliff Richard, Oliver Reed, Susannah York, Richard Attenborough, Maggie Smith, John Mills and Vanessa Redgrave. Constellation was badly affected by financial legislation passed by Parliament in 1969 and this year, reducing its capacity as a saving medium for high-earning stars and driving several of the latter abroad. Hemdale, whose artist roster includes Jack Wild, Mark Lester and Lynn Redgrave, has financed five major movies this year with big star names. It was originally formed by actor David Hemmings with John Daly as an artist service group, but Hemmings' connection is now minimal following a boardroom disagreement last year.

A. J. Mackenzie Smith, EMI Records international sales manager, died of cancer on August 17th aged 54. He originally joined the Gramophone Company Ltd. in 1934, and was named EMI Records export manager in August 1958. His Wimbledon funeral on August 20th was attended by many record industry representatives, including EMI Records assistant managing director Ron White and classical promotion manager Leonard Smith.

Quickies: Maurice Clark, formerly with Blue Ribbon Music here, has joined the Les Reed organisation to work on artist liaison and manage Reed's various publishing interests... Chrysalis Music general manager Bob Grace has signed Mike d'Abo's producer Chris Demetriou to a worldwide exclusive songwriting deal... well-known West End night club and discotheque La Valbonne wrecked by fire... Robert Paterson bringing B. B. King over for three-week European tour including initial British dates... Campbell Connelly to represent Miki Dallon's Youngblood publishing company in UK and certain European territories.

Great Britain's Best Sellers

This Week	Last Week	Album
1	1	I'm Still Waiting—Diana Ross—Tamla Motown—Jobette/Carlin
2	2	Never Ending Song Of Love—New Seekers—Philips—UA
3	7	What Are You Doing Sunday—Dawn—Bell—Shapiro Bernstein
4	5	In My Own Time—Family—Reprise—Bern
5	3	*Get It On—T. Rex—Fly—Essex Inter.
6	10	Soldier Blue—Buffy St. Marie—RCA—Cyril Shane
7	4	Devil's Answer—Atomic Rooster—B&C—GH. Sunbury
8	6	Tom-Tom Turnaround—New World—Rak—Chinnichap/Rak
9	9	*Won't Get Fooled Again—Who—Track—Fabulous
10	—	Hey Girl Don't Bother Me—Tams—Probe—Lowery
11	—	Let Your Yeah Be Yeah—Pioneers—Trojan—Island
12	—	*Bangla Desh—George Harrison—Apple—Harrisongs
13	20	It's Too Late—Carol King—A & M—Screen Gems
14	17	Move On Up—Curtis Mayfield—Buddah—Camad
15	12	Heartbreak Hotel—Elvis Presley—RCA—Chinnichap/Rak
16	8	Chirpy Chirpy Cheep Cheep—Middle of the Road—RCA—Flamingo
17	14	Leap Up And Down—St. Cecilia—Polydor—Jonjon
18	11	Me And You And A Dog Named Boo—Lobo—Philips—Carlin
19	18	Get Down And Get With It—Slade—Polydor—Bern
20	—	Back Street Love—Curved Air—Warner Bros.—Blue Mountain

*Local copyright

Top 20 Albums

1	Every Good Boy Deserves Favour—Moody Blues—Threshold
2	Bridge Over Troubled Water—Simon & Garfunkel—CBS
3	Ram—Paul McCartney—Apple
4	Blue—Joni Mitchell—Reprise
5	Mud Slide Slim—James Taylor—Warner Bros.
6	Every Picture Tells A Story—Rod Stewart—Mercury
7	Tapestry—Carol King—A & M
8	Tarkus—Emerson, Lake & Palmer—Island
9	Sticky Fingers—Rolling Stones—Rolling Stones
10	Tamla Motown Chartbusters Vol. 5—Various Artists—Tamla Motown
11	Master Of Reality—Black Sabbath—Vertigo
12	Love Story—Andy Williams—CBS
13	Top Of The Pops No. 18—Various Artists—Hallmark
14	Stephen Stills 2—Steve Stills—Atlantic
15	Split—Groundhogs—Liberty
16	C'mon Everybody—Elvis Presley—RCA
17	After The Gold Rush—Neil Young—Reprise
18	Hot Hits Six—Various Artists—M.F.P.
19	Andy Williams Greatest Hits—Andy Williams—CBS
20	Live Free—Free—Island

Italy's Best Sellers

This Week	Last Week	Album
1	1	Pensieri E Parole—Lucio Battisti—Ricordi Numero 1
2	2	La Riva Bianca La Riva Nera—Iva Zanicchi—Ri-Fi Ri-Fi Music/Mascotte
3	3	Amor Mio—Mina—PDU Acqua Azzurra/PDU
4	8	We Shall Dance—Demis—Philips Minos Music
5	4	Donna Felicita—I Nuovi Angeli—Car/JB Chappell
6	6	Casa Mia—Equipe 84—Ricordi Ricordi
7	9	Tweedle Dee Tweedle Dum—Middle of the Road—RCA
8	10	Tanta Voglia Di Lei—Pooh—CGD Tevere
9	5	Sempre Sempre—P. Gagliardi—King Indios/Usignolo
10	7	Era Il Tempo Delle More—Mino Reitano—Durium Fiumara

Mexico's Best Sellers

This Week	Last Week	Album
1	2	*Mary Es Mi Amor—Leo Dan—CBS
2	3	*Felicidad—Victor Yturbe—Philips
3	1	Love Story—Francis Lai—Gamma
4	7	Mozart 40—Waldo De Los Rios—Gamma
5	5	Love Her Madly—The Doors—Gamma
6	4	Close To You—Carpenters—A&M
7	8	*Va Cayendo Una Lagrima—Babys—Peerless
8	—	It's Too Late—Carole King—RCA
9	10	Riders In The Storm—The Doors—Gamma
10	—	Butterfly—Danyel Gerard—CBS

*Local

Belgium's Best Sellers

This Week	Last Week	Album
1	1	Borriquito (Peret—Supreme—Ho-Bel. Music).
2	2	The Fool (Gilbert Montagne—CBS—A. A. Music).
3	3	Aan Mijn Darling (Will Tura—Palette—Belmusic/Jean Kluger).
4	4	Sweet Hitch-Hiker (Creedence Clearwater Revival—U.A.—Essex).
5	11	One Way Wind (The Cats—Imperial).
6	6	Pour Un Flirt (Michel Delpech—Barclay—Peter Plum).
7	5	Vaarwel En Tot Weerziens (Paul Severs—Start—Start).
8	13	Listening To Mozart (Walter Scott—Biram—Jean Kluger).
9	9	Eat At Home (Paul & Linda McCartney—Apple—Essex).
10	30	Get It On (T. Rex—Stateside).

MOA Ops Announces JB Awards; Columbia Named Company Of Year

CHICAGO — Music Operators of America will give three JB (Jukebox) awards this year for the most popular artists and record on jukeboxes.

The association will also give a Record Company of the Year award. This particular award was not given last year because of insufficient response from MOA members.

The winners were decided by a panel of judges known as the MOA Awards Committee using as a basis for judgment a primary vote by the membership plus interviews with one stops and programmers.

MOA's Artist of the Year award was won by Charley Pride of RCA Victor. Charley Pride was highly popular with the jukebox-playing public, produced the greatest number of consistently good records and received the most location requests since Johnny Cash, according to the MOA Awards Committee. He was also a major seller on LPs, which created a demand for singles.

MOA's Artists of the Year award was won by Dawn (Bell). According to the committee, their records earned well, with two numbers liked by all type locations, even "easy listening" spots. Strong appeal to young and adults alike. Covered every location with them, i.e., "Knock Three Times" and "Candida."

"Rose Garden" by Lynn Anderson (Columbia) won MOA's Record of the Year award. According to the committee, it was a good earner, was popular with all age groups and in every type location. Impressive longevity on jukeboxes.

MOA's Record Company of the Year award was won by Columbia Records for a number of stated reasons by MOA members and committee. Demonstrated interest in the jukebox operator through mailing of samples and appointment of jukebox product coordinator. Promotion efforts especially noted, according to the committee. "Because of Ron Braswell's (jukebox coordinator) consistent mailings of new releases with title strips" said several members. "One of first companies to recognize



LYNN ANDERSON



CHARLEY PRIDE

value of operators" wrote another member. "Columbia puts out records by a nice variety of artists," writes yet another. "Excellent service to operators, and their promo records are useful and useable," writes another. Columbia won this award hands down. MOA members and the committee were genuinely impressed by Columbia's efforts this year.

MOA president Les Montooth will present the JB awards at the MOA banquet in the Sherman House, Chicago, October 17.



DAWN

MOA Expo To Repeat 1970 Success

CHICAGO — With all major phonograph and amusement machine factories contracted to exhibit their latest machines at the October 15-17 MOA Expo Seventy One, plus roughly the identical number of allied firms and

suppliers to the music and games business also signed, MOA's Fred Granger predicts another packed house for the Sherman House Hotel. "We may have one or two more ex-

(Cont'd on page 44)

EDITORIAL:

Pride of Ownership

In this day and age, many of our operating companies are "big business" all the way. Plenty of heavy deals always cooking. Lots of lunches, meetings and the like with department store reps, civic leaders and all the others who directly affect the juke and games business. Unfortunately for these heavy operators, they just don't get around the route much anymore.

Maybe that's okay, you say. After all, why does a man pour his blood and sweat into building a business if he still has to play with the nuts and bolts of it after so many years have gone by and it's thriving. Why can't he enjoy the good life now that he's a success? Sure he can . . . he's a fool if he doesn't. But the problem is to fall so far away from the route that it begins to fall apart.

Think about it. When was the last time you took the luxury of visiting your locations apart from contract time, or a major service call that required your assistance? You say there's not that much available to you to make these "courtesy calls". Well, you should make time just to check up on things, to see that the equipment looks as good as you'd like anything with your name on it to look. You should see if your machines are placed properly at each stop, if the personnel there are satisfied with service, if anybody's really interested in playing that game back in the corner, and so on.

In short, you should personally inspect your route locations to see if things are the way you want them to be. Call it good business sense or simply "pride of ownership" . . . but every operator, large or small, must make that colonel's inspection tour from time to time. Else, how can he push along all the new programs without fingertip knowledge of "all the troops in the field."



National Automatic Merchandising Association (N A M A) president G. Richard Schreiber met recently with President Nixon at the White House following a presidential briefing for business leaders. N A M A has been urging its members to contact Mr. Nixon and members of Congress to request reinstatement of the Investment Tax Credit. Mr. Nixon included the measure in his message on the economy August 15. Passage by Congress is necessary before the tax credit becomes law.



IN OUR
BUSINESS,
A LITTLE BETTER
IS A LOT



Because everybody's right in there with a good machine. And if we're going to convince anybody to buy the one we make, we've got to have a slight competitive edge. Here are some of the little edges we've given ourselves for this year. The Rock•Ola 444 for 1971 is a purple explosion of color and light. Just like the fashion industry.

It's got a new and simple flip-down title strip holder assembly for improved cleaning. And flip-down

title strip holders for changing ease. And a spring loaded dome that practically lifts itself for you. It's got integrated circuits and a computerized selection indicator that prints out the number of the record playing. 160 selections, tempered glare-proof glass,

and a modular approach to getting at the guts. Plus a lot of other new features with the operator in mind.

Those are Rock•Ola's little differences for this year. We think you'll agree they're a lot.

ROCK-OLA
THE SOUND ONE

800 North Kedzie Avenue, Chicago, Illinois 60651

Williams

KLONDIKE



SINGLE PLAYER GAME
Adjustable 3 or 5 Ball
REPLAY OR NOVELTY MODEL
2/25¢ Play is the Profit Way!

Williams

ELECTRONICS, INC.

3401 NORTH CALIFORNIA AVENUE
CHICAGO, ILLINOIS 60618
CABLE ADDRESS WILCOIN CHICAGO

AVAILABLE FOR IMMEDIATE DELIVERY
THROUGH YOUR WILLIAMS DISTRIBUTOR

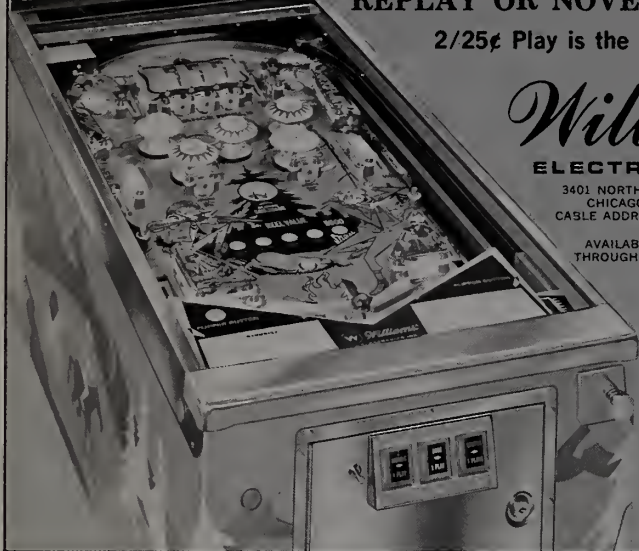
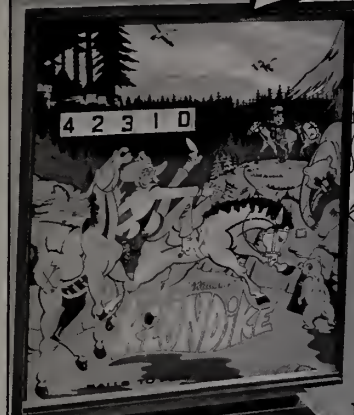

JUKEBOX PROGRAMMING GUIDE

Pop

TOMMY JAMES

I'M COMIN' HOME (2:03)
No Flip Info. Roulette 7110

THE FORTUNES

FREEDOM COMES, FREEDOM GOES (3:18)
No Flip Info. Capitol 3179

THE ISLEY BROTHERS

SPILL THE WINE (2:46)
No Flip Info. T-Neck 932

CYMARRON

VALERIE (1:58)
b/w Across The Kansas Sky (2:50)
Entrance 7502

THE JAMES GANG

MIDNIGHT MAN (2:40)
No Flip Info. ABC 11312

DAVE & ANSELL COLLINS

MONKEY SPANNER (2:43)
No Flip Info. Big Tree 125

YVONNE ELLMAN

EVERYTHING'S ALRIGHT (3:05)
No Flip Info. Decca 32870

C & W

MARTY ROBBINS

EARLY MORNING SUNSHINE (2:43)
No Flip Info. Columbia 45442

DAVID HOUSTON

HOME SWEET HOME (2:35)
No Flip Info. Epic 10778

JIMMY DICKENS

YOU ONLY WANT ME FOR MY BODY (2:32)
b/w What Will I Do Then (2:47)
UA 50834

R & B

THE FUZZ

I'M SO GLAD (2:41)
No Flip Info. Calla 179

JERRY BUTLER

WALK EASY MY SON (2:55)
b/w Let Me Be (3:00) Mercury 73241

BETTY EVERETT

I'M A WOMAN (2:47)
No Flip Info. Fantasy 667

'71 EXPO Report

(continued)

hibitors this year than last," said Granger. "There always are those who call at the last minute for space. But right now, all the popular factories, plus some of the record companies, as well as the suppliers, are all coming to Expo."

In addition to the trade showing itself, prime activities for convention-goers include the Industry Seminar on opening day (Oct. 15th, from 3:30 to 6:00 PM), the general membership meeting of MOA plus elections of officers for the 1971-72 term (Oct. 16th, 12:00 noon) and the gala banquet and stage show (Oct. 16th 7:00 PM).

The seminar this year will touch on important industry topics: the first, "programming country music on jukeboxes;" secondly, a panel discussion on "location and machine security measures."

The Country Music Association (coincidentally celebrating its own convention in Nashville same time as the Expo) will show its \$40,000 color film on country music in its presentation entitled "Why Operators Should Program Country & Western Music on Jukeboxes." A major executive of the CMA will host the presentation at this part of the seminar. Questions from the audience will be elicited after the film and verbal presentation are completed.

The second portion of the seminar, devoted to location security, will feature a panel of distinguished traders astute in the various measures and programs operators have employed in protecting their equipment on location.

New Products

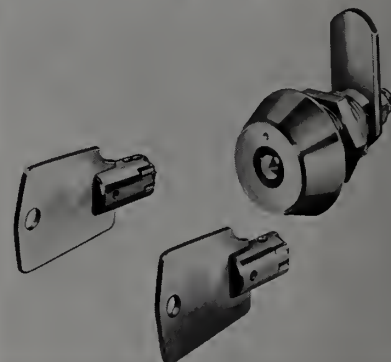

National Lock Hardware, Rockford, Illinois is now offering a new high security lock for vending machines. The lock is called KeSet and is designed to provide a fast combination change without removing the lock, or any parts, from the installation. When the service key is lost or a new individual is on the route, the lock may be opened only with the original set key. To re-program the lock a new combination set key is inserted and turned to the locked position. The lock is now newly programmed to operate with a new service key. KeSet is composed of 38 tumblers and driving pins arranged to provide two lines of cleavage, virtually eliminating picking and manipulation. Each series lock provides 64 combination changes permitting unrestricted route programming. Using KeSet reduces inventory of lock parts, only the change key is needed which is safely stored. All keys are assigned on an exclusive basis and are factory registered by means of confidential cards. Key blanks and code books are not available and duplicate keys are furnished exclusively by National Lock Hardware only to the registered owner.

All exposed surfaces of the lock are made of hardened or stainless steel to withstand strongarming. A specially shaped hardened plug resists punching. Tapered hardened steel freespinning collar prevents use of torquing tools to force entry. The keys are made of high strength steel utilizing a wrench type drive adding to key entry performance. Additional information is available by writing to: National Lock Hardware, Dept. KS, Rockford, Illinois 61101.

MORE PROFIT from your MUSIC LOCATIONS

See BANNER for the many reasons why Rowe-AMI MM5 & CADETTE will put more money in YOUR pocket.

BANNER SPECIALTY CO.

1213 N. 5th St., Phila., Pa. 215-236-5000
1508 Fifth Ave., Pgh., Pa. 412-471-1373

A Full Line of Coin Operated Recreational Tables from

American SHUFFLEBOARD COMPANY
210 PATERSON PLANK ROAD
UNION CITY NEW JERSEY

"The House That Quality Built"

Ets. RENE PIERRE Automatic Coin Games

B P 338

71 Chalon-sur-Saone France

Manufacturers of:

FOOTBALL

- Competition 71
- Derby Lux
- Derby Export

BILLIARDS

- American
- Golf
- Russian

TAM TAM • PING PONG



FOOTBALL COMPETITION 71

Exclusive representative for USA & Canada

CHARLES RAYMOND & CO. INC.

250 W. 57th Street, New York, 10019

for prices and information call (212) MU 9-0547

EASTERN FLASHES

ON THE AVENUE—Sales manager Irv Kempner at Runyon Sales Co., recently returned to work after spending a vacation holiday in England. And, Irv is back to greet the first offerings of the new fall line of equipment. Exec Lou Wolberg says that he rates the new Bally 'Road Runner' very highly. 'Road Runner' is on the showroom floor, and operators are welcome to stop by and test their driving skills. According to Lou, this novelty game has one of the most dramatic collision effects to really give the player a "jolt." A scary jolt at that, says Lou. A mirror image of a specially realistic 3-dimensional car when involved in a collision or the slightest contact of player's car with any rival car hurls the player's car in the air and completely tumbles over landing upright on the wheels. Of course, there are flashing landscape and speedway sound effects that adds to the play excitement of this tremendous game, says Lou . . .

Oresto Basulto Orestes Coin proprietor, has concluded a three week tour of Spain. Orestes said he had a wonderful time getting plenty of sun and swim time on the southern coast of Spain. And Orestes is still raving about one of the popular dishes in Spain. The dish is called 'Paella', we understand that it is a dish with three main ingredients of rice with fish and chicken. From what Orestes says, its a tasty dish. Orestes is still in the throws of getting back at the helm of the tenth avenue shop . . . We gave **Murray Kaye** a call at Atlantic New York Corp., who says that the new Seeburg has had an advanced sneak preview at the Seeburg showroom. The preview, says Murray, was for the benefit of some selected operators. Nothing but words of praise, these are the comments from the operators, says Murray . . . **Dick Greenberg** at Munves Corp., says that things are slowly, but surely, coming out of the summer season. Dick reports that **Raloh Hotkins** has returned from a southern Jersey jaunt.

BROOKLYN HAPPENINGS—Secretary Mimi Hannon (Red Circle Music Co.) had made all her arrangements with her boss **Otto Freedman** to take a summer vacation. When Mimi informed her fiance **Isaiah Jacob** that she had made her vacation arrangements, all sorts of events occurred. Isaiah, who a mechanical engineer, presented the properly prepared blueprint for his proposal and the answer was yes. The couple had a honeymoon vacation. Mrs. Jacob (Mimi) is now back from her vacation and is busy, she reports, helping Otto make arrangements to start phasing out the seasonal location stops. Of course, many operators are faced with the same problem. Arrangements have to be made to have the equipment removed from the stops and brought into the shop. Often times, the location may close promptly after the labor day week end. Proper planning and arranging becomes a necessity. Space is needed for the equipment and important decisions as to what items and pieces are ready for trade; these are all aspects of the busy operators life . . . We put a call into **Abraham Weisberg Service Co.**, Abe says that this is undoubtedly one of the most hectic times for his service route. The equipment has been going full blazes throughout the summer and minor service problems crop up; calls begin to pour in. Operators, of course, are anxious to have their equipment in top notch playing condition for the final big fling of the summer season. A reliable service company is a vital cog.

RECORD EVENTS—One stops are beginning to get themselves geared for the heavy schedule of fall releases from the record companies. **Otto Wilkinson** at A-1 Record Sales in Manhattan says that a group on the RCA label "New Birth" have recorded the Perry Como hit, 'Impossible' and the single seems destined to become a big juke hit. And, of course, **Otto** says that the Nite Liters with 'K-Jee' is one of the hottest movers in sometime . . . The Ghetto Records label headed by **Nellie & Leonard Williams** and **Ben Smith** has released a single record. The proceeds from the sale of the single are to go to the Frank Morris Foundation under supervision of the Federal Addiction Agencies, which is funded by Central Brooklyn Model Cities. The need for additional funds is necessary for a worthy cause, and in this case this a self help effort. The record was produced by individuals who are now actively engaged in drug rehabilitation programs. One side is called, "Goza El Ritmo," and call themselves El Combo Suprema. 'The Solid State' is the name for the group on the flip side doing a song entitled, "Rainy Night All Over." Both sides are commendable because of their self help efforts in re-entry programs at rehabilitation store front centers in Brooklyn.

ADDITIONAL DISTRIBUTOR NOTES—Got the word from Playmor prexy **Harold Kaufman** that the Chicoin 'Hi-Score Pool' is creating plenty of excitement. Operators are already on the waiting list. Game moves out almost as fast as Harold gets them into the Brooklyn plant. We also learned that Chicoin has shipped a sample of a new shuffle. Operators will be able to see at the Musical/Playmor showroom right after the labor day weekend. Seems as if the Chicoin plant has to gear up for an alltime production sked. The Chicoin machine gun 'Defender' it is an early fall novelty piece that looks like it will knock off plenty of previously established records. The gun, we understand, should soon be on the showroom floor.

HERE AND THERE—NAMA president G. Richard Schreiber had sent memos to the NAMA membership urging the members to write to their congressmen and senators. Members are requested to write to their congressmen and senators urging them to support passage of President Nixon's request for a 10% investment tax credit. The president proposed that a 10% investment tax credit be allowed for the year beginning August 15, 1971, and that a 5% investment tax be enacted for each year subsequent to August 15, 1972. The President's request must be passed by Congress. So all the letters urging support will help.

SIGNS OF THE TIMES—As things stand of this moment, Palisades Amusement Park is scheduled to close upon completion of the current operating season. Countless millions have visited this famed park for decades. Its closing is a sad note. The Palisades park has been a part of the summer action for millions who have thrilled to their first rides. Especially the roller coaster. Who hasn't compared this fantastic ride with the coaster at Coney Island or other top locations throughout the world. Fun and games are synonymous with Palisades. Those of us on the Manhattan side of the Hudson River are certainly going to miss the familiar sight of the famed Palisades bulletin sign flashing out messages that reflect colorfully on the waters of the Hudson. This was a tremendous showcase for the introduction of games in all categories. And, the operator surprises were unlimited and matchless as games would climb phenomenal heights in popularity. Lately, the ride operators had introduced rhythm & rock solid music that really seemed to flow with the thrills and chills of the spinning action. Too bad we have to bid adieu to this park.

CALIFORNIA CLIPPINGS

Jimmy Wilkins (Portale Automatic Sales) says that the Chicoin 'Hi-Score Pool' is rapidly becoming one of the big items in popularity. The sample shipments of the new Chicoin 'Defender' a new novelty of the first rank is also going to be a pace setter for the coming season, says Jimmy, the Rock-Ola 446 continues to reap new platitudes as it gains a name for beauty and profit on location. The furniture styled phono is truly a beauty and Jimmy says he can't wait for the new phono line, the MOA show is not too far off and lots of talk and excitement about the new Seeburg. It is going to be a beauty, says Bud. reports that the new Williams 'Klondike' a single player flipper is an eye appealing piece that has the operators seeing some fancy gold. Bud says 'Klondike' is a scoring delight for a single player. Bud is also raving about the inside dope about the new Seeburg. It is going to be a beauty, says Bud.

Edward A. Wiler, vice president of marketing for the business and industry group of Interstate United Corp. recently announced that **Walter R. Moore** has joined his sales staff and will take over sales responsibilities for Orange County. Previously, Moore served as sales manager for a toy manufacturer and held sales responsibilities for a vending firm . . . **Hank Tronick** at C. A. Robinson reports that the Midway rifle, "Wild Kingdom" has really caught on and is still garnering plenty of location coin, according to operator reports.

BUY

Bally

Road Runner

FOR

TOP EARNINGS

IN

EVERY TYPE OF LOCATION

EVERYWHERE

FROM JAPAN

KAY A. CHIBA

TO JAPAN

PORT P.O.
BOX 111
YOKOHAMA
JAPAN

CABLE ADDRESS
"KACTRAM"
Yokohama

Japanese made amusement machines; Sub-roc, Tank, Kiddie Rides, X-DB, S. Road-7, Golden Soccer, Clay Gun, Scramble.

Exclu. Representing:

MAR-MATIC'S GROUP
For JENNINGS SLOT MACHINES
KEENEY'S UPRIGHTS
SEA HUNT, BERMUDA HOPPER, POKER COASTER

WERTS NOVELTY CO., INC.
For ALL KINDS OF PUNCH-BOARDS AND TICKETS

DELTA MFG. CO., INC.
For BILLIARD COIN-OPERATED POOL TABLES

Used Binges, Bikini, CanCan, Lido, Roller Derby, Circus Queen, Big Wheel, German Wall Game, Bally and Keeney Uprights, Evans Winter-book, you name it — we buy it!

ELECTRIC SCOREBOARDS . . . 2 Models

10¢ 1-player or 2-player by simple plug switchover. Also 2 for 25¢ play. Easily serviced. Large metal coin box.

OVERHEAD MODEL
(Natural finish hardwood cabinet.)
Two faced. Scores 15-21 and/or 50 pts. F.O.B. Chicago . . . \$169.50

SIDE-MOUNT MODEL
(Walnut Formica finish.) F.O.B. Chicago . . . \$249.50

Heavy-Duty COIN BOX
Made of steel with dark brown baked enamel finish. 10¢ or 25¢ operation. Large coin capacity w/Ntl. Rejectors. Size: 8" x 16" x 4". Electric counter optional.

Large selection of billiard cloth, balls and cue sticks—
Write for New Catalog

MARVEL Mfg. Company
2845 W. Fullerton, Chicago, Ill. 60647
Phone (312) 342-2424

Proven Profit Maker!



CHICAGO COIN'S DEFENDER MACHINE GUN

- **REALISTIC MACHINE GUN**
Staccato bursts—vibrating action.
- **NO "SOUND NUISANCE"**
Telephone booth effect controls sound. Solid State Sound System.
- **WORLD WAR I BI-PLANES DIVE—CLIMB—CIRCLE!**

Many Other Profitable Features.

ALSO IN PRODUCTION
MARDI GRAS • APOLLO-14

Mrs. of PROVEN PROFIT MAKERS Since 1931

CHICAGO COIN MACHINE DIV
CHICAGO DYNAMIC INDUSTRIES, INC.
1775 W. OVERSEY BLVD CHICAGO ILLINOIS 60614

CHICAGO CHATTER

The local MOA office just issued its annual mailing to the foreign members of the coin machine industry, advising the dates, time and place of Expo '71. Last year, in direct response to this mailing, between 40 and 50 guests from various countries abroad attended the show. MOA has a special foreign relations-public relations committee within the association to assist the visitors and make them welcome . . . On the domestic scene—might mention that the advance registration cards for badges, hotel accommodations, and banquet reservations were also in the mail last week to the association membership. In view of the success of last year's Expo and the expected increase in attendance this year—ti would be very worthwhile to make your reservations as far in advance as possible.

BALLY-MIDWAY'S DIRECTOR OF MARKETING Ross Scheer was back in his busy office last week, following an extensive trip to the Far East.

THE NAME OF THE GAME IS "Wild Kingdom" and from what Larry Berke tells us it's chalking up just about the "biggest run in the history of Midway guns!" A fantastic seller, according to Larry, and just recently there's been a flood of orders marked for delivery during the back to school period, so the game's a big winner with all age groups!

WE WISH A SPEEDY RECOVERY TO Rock-Ola Mfg. Corp.'s ad manager George Hincker who's recuperating from pneumonia in Lutheran General Hospital (1775 Dempster, Skokie, Illinois). You can drop him a card in Room #566.

EDDIE ZORINSKY OF H. Z. VENDING & SALES in Omaha, and his wife Ceecee, will soon be departing for Hawaii on an all expenses paid trip as guests of the Phillip Morris Tobacco Co. H. Z. won the trip in at nationwide competition among cigarette distributors across the country. Hymie Zorinsky, of course, is quite proud and he was telling us that the Omaha papers really played up the event in a big way! Our congratulations! . . . By the way, Hymie also said he's anxiously awaiting his first shipment of the newly released D. Gottlieb & Co. 4-player "Sheriff"!

EMPIRE DIST.'S MURPH GORDON was in Sandusky, Ohio last week representing Empire at the IAAP meeting . . . On the home front, Gil Kitt, Joe Robbins, Jack Burns—all in town and plenty busy! Jack says it's been one heck of a good year for arcade equipment of all kinds! Great! He also mentioned that the floor model of ChiCoin's Hi Score Pool, which is currently on display at Empire, is attracting all sorts of attention and they're booking lots of orders for it pending forthcoming shipments from the factory.

ONTO THE MOA—Fred Granger running an extra-brisk work pace these weeks pulling all the strings together for the Oct. 15-17 MOA'er at the Sherman House. Speaking of that venerable Chicago institution, Fred happily advises all that hotel management has slated over \$2 million to refurbish the Sherman's rooms, halls and everything else. Much of the refinishing work has already been completed on the rooms and Fred advises us to tell the trade they will have first crack at the new rooms if they are able to get their registration cards in early enough. "Management has promised me that our conventioners will get first choice of the refurbished rooms and suites but I ask the members to get their reservations in as soon as they can (cards were sent last week)," says Fred.

MARSHALL TO THE EXPO—Heard happy news that Johnny Frantz (JF Frantz Mfg.) will be returning to the MOA Expo as an exhibitor this year, no doubt bringing us his US Marshall gun game. His booth should be busy place as he chats with old friends (moving more than a few guns in the process!).

MILWAUKEE MENTIONS

Local coin people are enjoying a preview of what's to come this fall from the various games factories. Several new releases are already on the market—ChiCoin's "Defender" machine gun, Gottlieb's "Sheriff" 4-player, Williams' "Klondike," Bally's "Expressway" and "Road Runner," to name a few. Looks like it'll be a great season!

TALKED TO JOEL KLEIMAN of Pioneer Sales & Services who received his first shipment of the aforementioned "Defender" produced by Chicago Dynamic Industries—and he's very enthusiastic about it! Joel says the recent refrigeration service school hosted by Pioneer was very successful and attracted a large number of vending operators from the area. He also mentioned that the distrib's been doing fantastic business with the new Rowe candy and snack venders!

THOUSANDS OF PARTS

Bally Bingos and Uprights,
Motors, Backglasses, Coils,
Relays, Assorted Parts.

Write for inventory:

Export & Import Company

P. O. Box 28

Highland Park, Illinois 60035

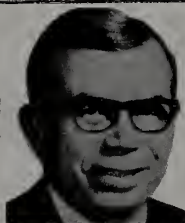

Active's
THE CHOICE FOR
the Lowest
Prices
and
Best Equipment
ALWAYS

Exclusive Gottlieb, Rock-Ola, Filscher and
Chicago Coin Distributor for Eastern Penn-
sylvania, South Jersey and Delaware.

ACTIVE Amusement Machines Co.
666 No. Broad Street, Phila. 30, Pa. 684-1600
1101 Pittston Ave., Scranton 5, Penna.



JOIN THE PARADE
to

Expo Seventy-One



71
EXPOSITION
OCT. 15, 16, 17

1971 MUSIC & AMUSEMENT
MACHINES EXPOSITION

Sherman House, Chicago

sponsored by

MUSIC OPERATORS OF AMERICA

THREE
GREAT
DAYS!

SPECTACULAR EXHIBITS

- Phonograph Manufacturers
- Record Manufacturers
- Amusement Games Manufacturers
- All Allied Industries

OUTSTANDING EVENTS

- Business Seminars
- MOA Complimentary Luncheon
- Ladies Program
- Gala Banquet Stage Show

MUSIC OPERATORS OF AMERICA

228 N. LaSalle Street • Chicago, Illinois 60601

COIN MACHINES WANTED

WANTED TO BUY OUT SELLING STOCKS ONE OR TWO years old Jennings slot machines, Wurlitzer juke boxes and Pinball games two or four players, make an offer to AUTOMATTJANST N STORGATAN 19 BJUV, SWEDEN.

"WANT"—Any quantity Keeney Plantations, Star-times, Haciendas, El Ranchos and Eleven Bells for export. Must be working and no parts missing. Send us your list and lowest prices. EVELYNE M. JOHNSON AMUSEMENT DEVICES, 414 Valley Avenue North East, Puyallup, Washington 98371. (206) TH 5-5163.

WE ARE ALWAYS INTERESTED IN USED AND BRAND NEW photographs, pinballs, bingos, guns, arcade, kiddie rides, slot machines, etc., all makes, all models. QUOTE FOB SEA VESSEL TO HOLLAND BELGIE EUROPE, SPRL, 276 AVENUE, LOUISE, BRUSSELS.

WANTED—Seeburg Consolettes, Phonographs, new and used, Phono Vue attachments and film, Scopitone film, Late Model Drive Machines and Guns, Harvard Metal Typers. Also interested in distribution of allied equipment. ST. THOMAS COIN SALES, 669 TALBOT ST., ST. THOMAS, ONTARIO, CANADA. (519) 631-9550.

WANTED TO BUY: Machines that can be easily moved and require little maintenance for Firemen's Bazaars. L. & L. Party Favors, Tender Street, Luzerna, Penna. 18709. Phone (717) 822-0000.

WANTED TO BUY AMI J-200, K-200, CONTINENTAL 2-200 Tropicana and Diplomat. We need Keeney uprights for export. Submit offers to Cross-Dunham & Co., 225 Wright Ave., "F", Gretna, Louisiana 70053.

WANTED FOR EXPORT TOP PRICES PAID—All late model 20-Hole and OK Bingo, All 6-card Bingo, Uprights and Slogs, Late Model 4-Player Bally & Williams. All Late Model Phono's and Wallboxes, Arcade, etc. Write or call Bob Jones for best prices. ROBERT JONES INTERNATIONAL, 19 Brook Road P.O. Box 181, Needham Hts. Mass. 92194 617-449-3330.

WANTED!—For Export Late Model BINGOS, BIKINI, CANCAN, LIDO, ROLLER DERBY, CIRCUS QUEEN, BIG WHEEL, EVANS WINTER BOOK, BALLY SLOTS & KEENEY MOUNTAIN CLIMBER. Contact us immediately! MARMATIC SALES CO., INC., 1140 E. Cold Spring Lane, Baltimore, Maryland 21239. (301) 435-1477.

COIN MACHINES FOR SALE

SLOT MACHINES FOR EXPORT/SALE—Bally, Mills, Pace, Jennings, Uprights, Consoles, Bally Bingo Pinballs, Automatic Horse Race, Automatic Poker, Keno, Bingos, Si Redd's Bally Distributing Company, 390 E. 6th St., P.O. Box 7457, Reno, Nevada 89502 (702) 323-6157. Las Vegas Office, 2409 Industrial Way, Las Vegas, Nevada 89102 (702) 382-4145.

FOR SALE: Model 14 Auto Photo. EXCELLENT condition. Call or write. New in original cartons. Hollywood Driving Range, 15 ball golf game. Cose-out \$295 ea. CLEVELAND COIN INTERNATIONAL, 2025 Prospect Avenue, Cleveland, Ohio. Phone (216) 861-6715.

ATTENTION WHOLESALERS & EXPORTERS. Have Wurl Amer III (3300) and Wurl Statesman (3400); also older Wurl models. Write for prices. United Dist., 902 W. 2nd, Wichita, Kansas.

ALL TYPES OF COIN OPERATED ARCADE EQUIPMENT for sale—guns, Helicopters, pinballs, etc. Auto Photo machines. Write for equipment list and prices. ROCK CITY DISTRIBUTING CO., INC., 615 Murrefreesboro Road, Nashville, Tenn. 37210.

UNITED AMUSEMENT INT'L offers you the largest selection of fully-reconditioned or as-is used coin-operated equipment. Also distributing the finest new coin-op soccer table on the market; immediate delivery now. Call or write: UNITED AMUSEMENT INT'L, INC., 51 Progress St., Union, N.J. Tel: (201) 686-7030. Cable UNITEAMUSE.

FOR SALE: Seeburg, Wurlitzer, Rockola. AMI phonographs, Williams, Gottlieb, Bally, Chicago Coin, flippers, guns, baseballs. United, Chicago Coin, Midway shuffles, Valley, Fischer, United, American, used pool tables. As is or shipped. Domestic or export shipments. Call or write Operators Sales, Inc., 4122 Washington Ave., New Orleans, Louisiana, 70125. (504) 822-2370.

FOR SALE: Cigarette Machines good and clean off location. can be used as is. Corsair 20. \$45.00; Rowe 20-700, \$60.00, Corsair 30 column. new front \$75.00. Send 1/2 deposit to Guerrini's, 1211 W. 4th St., Lewistown, Pa. 17044.

CLASSIFIED AD RATE 20 CENTS PER WORD

Count every word including all words in firm name. Numbers in address count as one word. Minimum ad accepted \$5.00. CASH OR CHECK MUST ACCOMPANY ALL ORDERS FOR CLASSIFIED ADVERTISING. If cash or check is NOT enclosed with order your classified ad will be held for following issue pending receipt of your check or cash. NOTICE—\$87 Classified Advertisers (Outside USA add \$52 to your present subscription price). You are entitled to a classified ad of 40 words in each week's issue for a period of One Full Year, 52 consecutive weeks. You are allowed to change your Classified Ad each week if you so desire. All words over 40 will be billed at the rate of 20¢ per word. Please count words carefully. Be sure your Classified Ad is sent to reach New York publication office by Wednesday, 12 noon, of preceding week to appear in the following week's issue.

Classified Ads Close WEDNESDAY

Send all copy to: CASH BOX, 1780 Broadway, N.Y., N.Y. 10019

FOR SALE: Snow Queen, \$580; Playball, \$470; Now, \$625; Ringer, \$365; Wms: "500", \$375; Firecracker, \$575; Space Flight, \$365; Missile, \$325; Jet Rocket, \$750; Combat, \$775; Rifleman, \$225; Motopolo, \$285; C. C. Pro-Basketball, \$125; C. C. Apollo M. S. Rifle, \$325; White Lightning, \$255; Helicopter Trainer, \$250; Computer Quiz, \$325; Wild Cycle, \$490; C. C. Drive Master, \$325; Also Bingos. NEW ORLEANS NOVELTY CO., 1055 Dryades Street, New Orleans, Louisiana 70113. Tel (504) 529-7321 CABLE: NONOVCO.

FOR SALE/EXPORT — USED SLOTS: BALLY STANDARD, 3 Line Play, Multipliers, Quick Draws. Assorted Mills. Electric Payout Jennings. Space Jet Bell, Segas. Assorted Bally Bingos. "Games" Upright Multipliers. Write for particulars THOMAS TRADING COMPANY, 2622 Westwood Drive, Box 15391, Las Vegas, Nevada 89114. (702) 734-8818. Cable—VEGAS.

FOR SALE/EXPORT: 3 new Silver Salls in original factory crates, 3 used Silver Salls, Bikinis, Lidos, Can-Cans, Roller Derbys, Laguna Beaches, County Fairs, Sea Islands, Ballerinas, Carnival Queens, Beach Times, Miss Americas, Sun Valleys, Cypress Gardens, Touchdowns, Show Times, Key Wests, Big Shows, Miami Beaches, Night Clubs, Broadways, Big Times, Barrels-O-Fun, Lotta-Fun, 3 Black Dragons, 2 Jumbos, 1 Sweet Shawnee. All equipment crated securely in new bingo-type cartons, from Seattle port. Spare backglasses and parts available. One-ball Games: Lexingtons, Turf Kings, Jockey Clubs, Victory Derbys, High Steppers, Entries, with automatic pay-out drawers. Clean, ready for crating. Inquiries to MUSIC-VEND DISTRIBUTING CO., 100 Elliott Avenue West, Seattle, WA 98119. Phone (206) 284-7740. Cable address: MUSIVEND. We welcome all foreign commerce buyers.

"MARMATIC", Exclusive World-Wide Reps. for the Newest JENNING'S Electronic Slots, KEENEY'S MOUNTAIN CLIMBER & 7 coin multiple FLAMING ARROW UPRIGHTS. Available in Free Play or Cash Payout. We also carry a complete line of A-1 USED—JENNING'S, KEENEY MILLS S'ots, BALLY S'ots & Bingos. MARMATIC SALES CO., INC. 1140 E. Cold Spring Lane, Balto., Md. 21239. (301) 435-1477.

FOR SALE: United Shuffles: Delta, \$450; Gamma, \$525; Williams Add-A-Balls: Rock & Roll, \$375; Gridiron, \$350. (No Crating) MOHAWK SKILL GAMES CO., 67 Swaggettown Road, Scotia, N. Y. 12302. (518) 377-2162

STEREO PICK-UPS: "SMC" FOR SEEBURGS "B" through "201" \$20; "WMC" for Wurlitzer Cobra. \$10. SOUND & SIGNAL SERVICE, Box 10052, Albuquerque, N. Mex. 87114.

FOR SALE: 3 SPEED QUEEN BY BALLY—BOATS. \$275 each. 3 Elephants by Tusko—\$275 each. CENTRAL MUSIC CO., P.O. Box 284, 407 E. Ave. D. Killeen, Texas 76541.

FOR SALE: AUTHORIZED DISTRIBUTOR FOR VALLEY Pool tables and Rock-Ola Phonographs. Write or call for prices. Budge Wright's Western Distributors, 1226 SW 16th, Portland, Oregon. Phone 228-7565.

FOR SALE: PANORAMS—NEW—WITH OR WITHOUT Sound. Write or call URBAN INDUSTRIES INC., P.O. Box 31, Louisville, Kentucky 40201. (502) 969-3227.

ATTENTION DISTRIBUTORS/EXPORTERS: Late novelty games available for sale or trade. Speedways, Motorcycles, Wild Cycles, Sea Devils, Invaders, S.A.M.I.s. Sonic Fighters, Space Flights, Computers. Uncramped. Late guns. CENTRAL DISTRIBUTORS, Wholesale Division, 2315 Olive, St. Louis, Mo. 63103. Phone (314) 621-3511.

FOR SALE—Off Location—As Is Condition—Complete—No Break-Ins: 50 Rowe 20/700 Cigarette. 5 Corsair 20 Column Cigarette. The MACKIE COMPANY OF CENTRAL PENNSYLVANIA, 1201 South 20th Street, Harrisburg, Pa. 17104. (717) 238-1768. Mannie Silvia.

FOR SALE: 12-R.C.A.-16 MM PANORAMS. PEEP shows wt. timers mint cond. Also film girlie nudes b & w used \$8.00. Color \$25. App. 400 ft. each. Money makers. RICHTER, 1063 Market St., San Francisco, Calif. Z 94103.

ALL TYPES OF COIN-OPERATED EQUIPMENT: ADD-A-Balls, shuffles, guns, computers, etc. All types of phonographs, large selection on hand. Vending machines, from cigarette to candy to can drink, etc. . . . all kinds, shipped to perfection. Write or call FLOWER CITY DIST. CO., 389 Webster Ave., Rochester, N.Y. 14609. Tel. (716) 654-8020 and ask for JOE GRILLO.

FOR SALE: Two Panoram peep show machines with optional 25c or 50c coin chuff. Continuous reel that holds 1,000 ft. of 16mm film. Operated with a time unit. PHIL GOULD, 224 Market Street, Newark, N.J. Tel. 201—Market 4-3297.

POOL TABLES—Large selection of all makes and models available. Completely reconditioned or in "as is" condition for immediate shipment at very attractive prices. Also large selections of pin games, snuffles, guns and music—Phone or write EASTERN NOVELTY DISTRIBUTORS, INC., 3726 Tonnee Avenue, North Bergen, New Jersey 07047—(201) 864-2424.

FOR SALE: Keeney Twin Dragons, Black Dragons, Mountain Climbers, Flaming Arrows, Buckley Track Odds. Slots, Saskatchewan Coin Machine Co., 1025-104th St., North Battleford, Saskatchewan, Canada. Phone (306) 445-2989.

NEVADA FRUIT SLOT MACHINE offers for Export 15 Brand New Silver Salls in Original Crates \$1150.00 each. 346 Bally Bingos sold in Quantity Mostly O.K. Models to Can Can and Lidos \$349.00 each. Write, Call or Wire. Nevada Fruit Slot Machine Co., P.O. Box 5734 Reno, Nevada 89503 (702) 329-3932.

FOR SALE: Chicago Coin Super Circus, \$450; Midway Sea Raiders, \$350; Bingos for export; Orients, \$1100; Bountys, \$550; Big Wheels, \$650; Pin Balls also available. D. & P. MUSIC CO., 27 E. Philadelphia Street, York, Pa. 17401. Phone (717) 848-1846.

FOR SALE: CLOSEOUT BARGAINS COMPLETELY RECONDITIONED: Bally Space Flight (late Model) Moon Lander game \$345.00; Bally (5 ball pinballs) Gators (4 pl) \$395.00; Dogies (4 pl) \$345.00; Blue Ribbon (4 pl) \$145.00; Rocket III (1 pl) \$145.00; Discotek (3 pl) \$95.00; Gottlieb (5 balls) Buckaroo (1 pl) \$125.00; Cross Town (1 pl) \$165.00. Mickey Anderson Amusement Co., 314 E. 11th St., Erie, Pa. 16503, Phone (814) 452-3207.

FOR SALE: 'New Munves "Love Tester."' Ideal for arcades, game rooms, terminals, etc., 5 or 10 cent play. Write for details, and latest inventory list. Will swap machines. What do you have? MUNVES CORP., 577 Tenth Avenue, New York City, N.Y. 10036. Phone (212) 279-6677.

FOR EXPORT: MADE IN JAPAN AMUSEMENT MACHINES: Sub-roc, Tank, Kiddie Rides, X-08, S. Road-7, Golden Soccer, Clay Gun, Scramble. Contact: KAY A. CHIBA, Port P.O. Box 111, Yokohama, Japan. CABLE: 'KACTRAM'.

BINGOS AND SIX-CARD GAMES AVAILABLE. ALSO Keeney Red Arrows and Big 3's. These games are completely shipped. Call WASSICK NOVELTY, (304) 292-3791, Morgantown, W. Va.

FOR SALE: UNITED SHUFFLE ALLEYS—BETA, GAMMA, PEGASUS MAMBO. CHEETAH, MIDWAY-SEA RAIDER: ROCK-OLA 426: WURLITZER 2800. D&L DISTRIBUTING CO., INC., 5550 Derry St., Harrisburg, Pa. 17111 (717-564-2520).

FOR EXPORT—Winter Books, Track Odds, Sea Island, Ballerinas, Miss Americas, Cyprus Gardens, Show Time, Sun Valley and OK Feature Games. Lowell Associates, PO Box 386, Glen Burnie, Md. 21061. (301) 768-3400.

FOR SALE: Lucky Penny Sweeostakes \$150.00, Grip Test \$150.00, Sea Raider \$350.00, Drive Master \$350.00, Helicopter Trainer \$125.00, Unscramble \$95.00, I. Q. Computer Model 1Q105 \$325.00, Wurlitzer 2310 \$95.00, Wurlitzer 2'10 \$150.00, 9 ft. Coin Operated American Shuffleboard like new \$225.00. Send 1/2 deposit to Guerrini's, 1211 West 4th St., Lewistown, Pa. 17044.

SLOT MACHINES: New SEGA-DIAMOND, \$200; WINDSOR, \$300. CONTINENTAL, \$450; Used BALLY—Hold & Draw Models, \$275; Uprights, \$475; Super Jolly Taverners, \$250; In very good condition. P. R. W. (SALES) LTD., Phonographic House, The Vale, London, NW 11 8SU, Telephone: 01-450-5251 or 01-450-5221 Cables Phonograph London Telex: 27436.

HUMOR

MOO RECORD. Send \$1.00 to CAT, Suite 224, 2801 E. Oakland Park, Ft. Lauderdale, Fla. 33306.

'DEEJAY DIGEST' Comedy Service; in twelfth year. Only air tested material, exclusively for jocks, worldwide. Also unique publicity, promotions, personalized sound ID's etc., available. Send \$2.00 plus suitable postage for Digest and lists. No C.O.D.'s or "Freebies." MORRIS, 7047 Franklin, Hollywood.

DEEJAYS! 11,000 new classified gag lines, \$10. Or send \$19.95 for above, plus 15,000 additional Clever Remarks. Guaranteed the best comedy you've ever purchased or we'll refund your money! Catalog free on request. Edmund Orrin, Boyer Road, Mariposa, Calif. 95338.

THE ORBEN COMEDY LETTER and Current Comedy. 48 issues yearly. Professional laugh services written by Robert Orben, best-selling author and Hollywood television writer. Send \$3 for samples and details. Comedy Center, 1529 East 19th Street, Brooklyn, New York 11230.

DEEJAY GAGS UNLIMITED. VOLUME ONE. 600 Openings, Closings, Cross Plugs, Weird Gifts, Reading Mistake, Bad Joke, Artist, Record, Staff One-Liners. NOTHING LIKE IT. 100% Usable, Funny Or Money Back. Send \$7.50 To GAGS UNLIMITED, BOX 2561, MOBILE, ALABAMA 36601

EMPLOYMENT SERVICE

MECHANIC WANTED. Good pay for experienced man. Write or call: Moder Amusement Co., 354 Saw Mill River Road, Yonkers, N.Y. 10701. Tel: (914) YO 8-7807.

BINGO MECHANICS WANTED: Legal territory of Nevada. 5 day, 40 hour work week. MUST have past Bingo experience. State age, references, past experience. Send photo if possible. Write or phone. UNITED COIN MACHINE CO., 2621 South Highland, Las Vegas, Nevada. Phone (702) 735-5000.

MECHANICS WANTED FOR MUSIC AND PINS. SALARY commensurate with ability. Time and half for over forty hour week. Liberal fringe benefits, plus vehicle. Contact AMUSE-A-MAT CORP., 123 E. Luzerne St., Philadelphia, Pa. 19124. Telephone (215) 329-5700.

WANTED: EXPERIENCED JUKE BOX AND GAME Mechanic. Good working conditions. Paid Vacations, sick leave, time and one half for overtime to reliable man. Call Mr. Anderson Collect person to person. Telephone 237-1563. Coin Music, Inc., 710 R St., Fresno, California.

EXPERIENCED MECHANICS WANTED. Phonos, Games, Cigarettes NO ALCOHOLICS, all fringe benefits including opportunity to buy company Stock, Large Route, Live Next to Colorado's beautiful Mountains, no Big City Problems. Call Collect Peerless-E.M. Music Co., Colorado Springs, Colorado 303-634-1411.

RECORDS-MUSIC

WANT RECORDS: 45's AND LP'S SURPLUS RETURNS, overstock cut-outs, etc. Call or write HARRY WARRINER at KNICKERBOCKER MUSIC CO., 453 McLean Ave., Yonkers, New York 10705 (914) GR 6-7778.

"FRIENDS SPECIALS" 100 Assorted LP Albums (mixed music) \$38.00 postpaid. 40 Assorted C/W Albums (top names) most stereo \$30.00 postpaid. Mens or Womens handmade leather briefcases. \$15.60 per assorted dozen. (F.O.B. Rootstown) Also send for free price lists of our other specials; records, novelties, gifts, "wholesale only." FRIENDS WHOLESALE, 3659 State Route 14, Rootstown, Ohio 44272. Phone (216) 325-7708.

ATTENTION RECORD COLLECTORS-DEALERS: 1,000 45's, \$57.00. 100 assorted, \$8.00, plus postage. Send \$1.00 for Auction, Sales Catalogs, surveys. Want lists welcome. LEE'S MUSIC CENTER, 6265 S. W. 8 Street, Miami, Florida 33144.

USED 45 RPM RECORDS. ALL TYPES AS THEY RUN, right off the route. No sorting or picking. We pay freight from anywhere in U.S.A. Standing order available for regular shippers. JALEN AMUSEMENT CO., 1215 HOWARD STREET—BALTIMORE, MARYLAND 21230.

ATTENTION RECORD OUTLETS. WE HAVE THE LARGEST selection of major label albums at promotional prices. Write for our complete listings of Jazz, Rock, Soul, Folk, Blues, Spirituals, etc. International Orders Welcome. SCORPIO MUSIC DISTRIBUTORS, 6720 Broad Street, Philadelphia, Pa. 19126.

WANTED TO BUY—OPEN REEL TAPES. WHY TIE UP capital investment in slow-moving reel tape department? We will buy complete inventories—large or small. Send detailed lists and quantities. VARIETY AUDIO PRODUCTS, 170 Central Avenue, Farmingdale, N.Y. 11735. 516—293-5858.

HOUSE OF OLDIES, WE SPECIALIZE IN ROCK 'N Roll and Rhythm, Blues oldie albums and 45's. Send \$1.00 for oldie album catalog, \$2.00 for foreign catalog. Attention: Dave, the Album Man, 267 Bleecker St., NYC 10014. Phone (212) 243-0500.

HOE DOWN FIDDLE TUNES—COUNTRY—BLUE GRASS—Record Albums—Tape Cartridges. New recordings of the legendary J. E. Malner. He will scare hell out of you. Wholesale to established Record Stores. UNCLE JIM O'NEAL, Box A-C, Arcadia, California 91006.

LEADING TAPE WHOLESALE WILL SELL HIGHEST chart tapes at lowest prices. Send for current list. CANDY STRIPE RECORDS, 17 Alabama Ave., Island Park, N.Y. 11558.

COIN MACHINE SERVICES

ACE LOCKS KEYS ALIKE. SEND LOCKS AND THE key you want them mastered to \$1.00 each less 10% lots of 50 or more. RANDOL LOCK SERVICE, 61 ROCKAWAY AVENUE, VALLEY STREAM, N.Y. 11580, TEL: 516-VA 5-6215. OUR 35TH YEAR IN VENDING.

SPEED UP YOUR COIN COLLECTIONS—New portable coin sorting, counting and packing machine, combined as one unit—hand operated—portable—weighs 18 pounds—with automatic stops and tubes for different sizes. Apply SEIFERT MACHINERY CO., Box 3421, Philadelphia, Pa. 19122.

FLOATING FUN BALLOON VENDING MACHINE. Does not have to be attended. Space age memory control panel, 25¢ Vend. Literature at your request. Dukane Ski N Skore and Grand Prix Parts Available. NOVEMBER CORPORATION, 1351 W. Grand Ave., Chicago, Ill. 60622. Tel. (312) 733-2988.

CLASSIFIED POWER!

CLASSIFIED AD RATE 20 CENTS PER WORD

Got machines to sell? 's there something you're looking to buy? Maybe you'd like to move some used 45's or need a route mechanic? For every coin machine need, use the Cash Box Classified.

Type Or Print Your Ad Message Here:

Classified Ads Close WEDNESDAY

Send all copy to: CASH BOX, 1780 Broadway, New York, N.Y. 10019

New Jefferson Airplane
on the Grunt label
shipping now FTR-100
certified gold P8FT-100
PKFT-100



Manufactured and distributed by RCA Records