



FOUNDED BY BILL GERSH

Cash Box

Vol. XXVII—Number 4

August 14, 1965

Cash Box

(Publication Office)

1780 Broadway
New York 19, N. Y. 10019

(Phone: JUdson 6-2640)

CABLE ADDRESS: CASHBOX, N. Y.

JOE ORLECK

President and Publisher

NORMAN ORLECK

Vice President

GEORGE ALBERT

Vice President

MARTY OSTROW

General Manager
MUSIC & RECORDS

EDITORIAL

IRV LICHTMAN *Editor-in-Chief*
DICK ZIMMERMAN *Associate Editor*
MIKE MARTUCCI *Editorial Assistant*
JERRY ORLECK *Editorial Assistant*
MARV GOODMAN *Editorial Assistant*
TOM McENTEE *Editorial Assistant*

ADVERTISING

BILL STUPER
HARVEY GELLER, Hollywood

ED ADLUM

General Manager
COIN MACHINES & VENDING

LEE BROOKS, Chicago, Ill.

ART DIRECTOR—GEORGE GOLDMAN

CIRCULATION—THERESA TORTOSA, Manager

CHICAGO

LEE BROOKS
29 E. Madison St.,
Chicago 2, Ill.
(Phone: Financial 6-7272)

HOLLYWOOD

HARVEY GELLER
6290 Sunset Blvd.,
Hollywood 28, Cal.
(Phone: HOLLYWOOD 5-2129)

EUROPEAN DIRECTOR NEVILLE MARTEN

ENGLAND

NEVILLE MARTEN
Dorris Land
9a New Bond St.
London, W1, Eng.
Tel: Hyde Park 2868

HOLLAND

PAUL ACKET
Thereslastraat 11-13
The Hague
Tel: 838500*

ITALY

MARIO PANVINI ROSATI
Viale Legioni Romane 6
Milan Tel: 4075618

FRANCE

CHRISTOPHE IZARD
24 Rue Octave Feuillet,
Paris XVI Tel: 870-9358

BELGIUM

FRANS ROMEYNS
Paul Hymanslaan, 8,
Brussels 15, Tel: 71.57.51

ARGENTINA

MIGUEL SMIRNOFF
Rafaela 3978,
Buenos Aires,
Tel: 69-1538

CANADA

JOHN MURPHY
87 North Hill St.
Port Arthur, Ontario
Tel. (807) 344 3526

SPAIN

FEDERICO HALPERN
Sagasta 23,
Apartado 4025,
Madrid
Tel. 257 0907—224 8600

GERMANY

MAL SONDOCK
Josef Raps Strasse 1
Munich, Germany
Tel: 326410

SCANDINAVIA

SVEN G. WINQUIST
Kageholmsvagen 48,
Stockholm-Enskede,
Sweden, Tel: 59-46 85

AUSTRALIA

RON TUDOR
8 Francis St.,
Heathmont, Victoria
Tel: 87-5677

MEXICO

ENRIQUE ORTIZ
Insurgentes Sur 1870
Mexico 20, D. F.,
Tel: 24-65-57

BRAZIL

LUIS DE M. C. GUEDES
Rua Augusta 2110,
sobre-loja, Sao Paulo,
Tel: 35-36-53

JAPAN

Adv. Mgr.:
SHOICHI KUSANO
Editorial Mgr.:
MORIHIRO NAGATA
466 Higashi-Oizumi
Neirimaku,
Tokyo

from the desk of . . .

JOE ORLECK

OF



August, 1965

Dear Friends:

One of the most inspired and oft repeated slogans is the present Rheingold Beer's "We don't know what it is—but we must be doing something right."

As Cash Box presents its Annual Directory and 23rd Anniversary Issue, we would like to borrow this pertinent statement—with an important change. "We must be doing something right"—BUT we KNOW what it is.

Cash Box, for 23 years, has been serving the industry, and serving it well. We KNOW the needs and problems of the Music and Record firms—and direct our complete energies and intelligence to help make it grow and prosper. One of the reasons, perhaps, for the continuing and expanding success of Cash Box is its faculty to remain young, to keep up with the musical times—yet to be fully cognizant of the fact that what is old is not necessarily out-of-date in terms of the demands of the industry thruout the world. An unusual combination of youth, experience and know-how.

As the World of Music continues to flourish and grow, Cash Box is grateful that its stature, as the leading trade publication, is given the opportunity to grow with it. We thank all our friends thruout the world for making it possible.

President and Publisher

SUBSCRIPTION RATES \$15 per year anywhere in the U. S. A. Published weekly. Second class postage paid at Bristol, Conn. 06012, U.S.A.
Copyright © 1965 by The Cash Box Publishing Co., Inc. All rights reserved. Copyright under Universal Copyright Convention.



Cash Box TOP 100



AUGUST 14, 1965

	8/7	7/31
1 I GOT YOU BABE		
☆SONNY & CHER-Atco-6359	4	21
2 WHAT'S NEW PUSSY CAT?		
☆TOM JONES-Parrot-9765	2	3
3 SATISFACTION		
☆ROLLING STONES-London-9766	3	1
4 I'M HENRY THE VIII		
☆HERMAN'S HERMITS-MGM-13367	1	2
5 SAVE YOUR HEART FOR ME		
☆GARY LEWIS-Liberty-55809	5	5
6 DON'T JUST STAND THERE		
☆PATTY DUKE-United Artists-875	7	10
7 CALIFORNIA GIRLS		
☆BEACH BOYS-Capitol-5464	21	41
8 HELP		
☆BEATLES-Capitol-5476	36	71
9 ALL I REALLY WANT TO DO		
☆CHER-Imperial-66114	10	12
☆BYRDS-Columbia-5332		
10 DOWN IN THE BOONDOCKS		
☆BILLY JOE ROYAL-Columbia-43305	13	23
11 IT'S THE SAME OLD SONG		
☆FOUR TOPS-Motown-1081	18	38
12 HOLD ME, THRILL ME		
☆MEL CARTER-Imperial-66113	14	22
13 BABY I'M YOURS		
☆BARBARA LEWIS-Atlantic-2283	16	24
14 UNCHAINED MELODY		
☆RIGHTEOUS BROS.-Philles-129	27	33
15 I WANT CANDY		
☆STRANGELOVES-Bang-501	12	14
16 I LIKE IT LIKE THAT		
☆DAVE CLARK FIVE-Epic-9811	6	7
17 LIKE A ROLLING STONE		
☆BOB DYLAN-Columbia-43346	37	54
18 PAPA'S GOT A BRAND NEW BAG		
☆JAMES BROWN-King-5999	24	35
19 I'M A FOOL		
☆DINO, DESI, AND BILLY- Reprise-0367	26	32
20 TRACKS OF MY TEARS		
☆MIRACLES-Tamla-54118	28	36
21 NOTHING BUT HEARTACHES		
☆SUPREMES-Motown-1080	38	62
22 CARA MIA		
☆JAY & AMERICANS- United Artists-881	8	6
23 TAKE ME BACK		
☆LITTLE ANTHONY & IMPERIALS- DCP-1136	22	27
24 YOU WERE ON MY MIND		
☆WE FIVE-A & M-770	40	73
25 I CAN'T HELP MYSELF		
FOUR TOPS-Motown-1076	9	4
26 WHAT THE WORLD NEEDS NOW IS LOVE		
☆JACKIE DE SHANNON- Imperial-66110	11	8
27 TOO MANY RIVERS		
☆BRENDA LEE-Decca-31792	15	17
28 YOU'D BETTER COME HOME		
☆PETULA CLARK- Warner Bros.-5643	33	39
29 THEME FROM A SUMMER PLACE		
☆LETTERMEN-Capitol-5437	17	19
30 HEART FULL OF SOUL		
☆YARDBIRDS-Epic-9823	61	79
31 JU JU HAND		
☆SAM THE SHAM & PHARAOHS MGM-13364	53	77
32 SUNSHINE, LOLLIPOPS & RAINBOWS		
☆LESLEY GORE-Mercury-72433	19	20
33 LOOKING THROUGH THE EYES OF LOVE		
☆GENE PITNEY-Musicor-1103	51	67
34 PRETTY LITTLE BABY		
☆MARVIN GAYE-Tamla-54117	20	25

	8/7	7/31
35 SINCE I LOST YOU BABY		
☆TEMPTATIONS-Gordy-7043	46	61
36 NEW ORLEANS		
☆EDDIE HODGES-Aurora-153	41	48
37 IN THE MIDNIGHT HOUR		
☆WILSON PICKETT-Atlantic-2289	49	60
38 ONE DYIN' AND A BURYIN'		
☆ROGER MILLER-Smash-1994	30	31
39 TO KNOW YOU IS TO LOVE YOU		
☆PETER & GORDON-Capitol-5461	25	28
40 YOU TELL ME WHY		
☆BEAU BRUMMELS-Autumn-16	50	64
41 YES I'M READY		
☆BARBARA MASON-Arctic-105	32	9
42 SUGAR DUMPLING		
☆SAM COOKE-RCA Victor-8631	56	72
43 HOUSTON		
☆DEAN MARTIN-Reprise-0393	70	—
44 THE IN CROWD		
RAMSEY LEWIS-Argo 5506	64	78
45 HUNG ON YOU		
☆RIGHTEOUS BROS.-Philles-129	48	58
46 IT AIN'T ME BABE		
☆TURTLES-White Whale-222	66	100
47 I'LL ALWAYS LOVE YOU		
☆SPINNERS-Motown-1078	44	50
48 MARIE		
☆BACHELORS-London-9762	23	16
49 RIDE YOUR PONY		
☆LEE DORSEY-Amy-927	29	29
50 A LITTLE YOU		
☆FREDDIE & DREAMERS- Mercury 72462	62	80
51 MOON OVER NAPLES		
☆BERT KAEMPFFERT-Decca-31812	52	53
52 SHAKE & FINGERPOP		
☆JR. WALKER & ALL STARS- Soul-35013	65	84
53 ONE STEP AT A TIME		
☆MAXINE BROWN-Wand-185	55	55
54 SEVENTH SON		
☆JOHNNY RIVERS-Imperial-66112	35	13
55 YOU TURN ME ON		
☆IAN WHITCOMB-Tower-134	34	11
56 EASY QUESTION		
☆ELVIS PRESLEY-RCA Victor-8585	43	30
57 A LITTLE BIT OF HEAVEN		
☆RONNIE DOVE-Diamond-184	31	15
58 AGENT 00 SOUL		
☆EDWIN STARR-Ric-Tic-103	75	93
59 I DON'T WANNA LOSE YOU BABY		
☆CHAD & JEREMY-Columbia-43339	79	—
60 YOU'RE MY BABY		
☆VACELS-Kama Sutra-200	63	70
61 NO PITY IN THE NAKED CITY		
☆JACKIE WILSON-Brunswick-552	54	56
62 SITTING IN THE PARK		
☆BILLY STEWART-Chess-1932	42	26
63 IT'S GONNA TAKE A MIRACLE		
☆ROYALTTES-MGM-13367	78	85
64 SAD, SAD GIRL		
☆BARBARA MASON-Arctic-108	77	—
65 WE GOTTA GET OUT OF THIS PLACE		
☆ANIMALS-MGM-13382	—	—
66 IT'S GONNA BE FINE		
☆GLENN YARBROUGH- RCA Victor-8619	67	74
67 I'M A HAPPY MAN		
☆JIVE FIVE-United Artists-853	69	76
68 IF I DIDN'T LOVE YOU		
☆CHUCK JACKSON-Wand-188	76	82

	8/7	7/31
69 YOU BETTER GO		
☆DEREK MARTIN-Roulette-4631	74	89
70 IT'S TOO LATE BABY TOO LATE		
☆ARTHUR PRY SOCK-Old Town-1183	73	81
71 ANNIE FANNY		
☆KINGSMEN-Wand-189	84	—
72 ONLY THOSE IN LOVE		
☆BABY WASHINGTON-Sue-129	89	95
73 FLY ME TO THE MOON		
☆TONY BENNETT-Columbia-43331	60	66
74 SIMPEL GIMPEL		
☆HORST JANKOWSKI-Mercury-72465	88	—
75 THE SWEETHEART TREE		
☆JOHNNY MATHIS-Mercury-72464	82	—
76 COLOURS		
☆DONOVAN-Hickory-1324	86	—
77 OOWEE, OOWEE		
☆PERRY COMO-RCA Victor-8636	80	100
78 IS IT REALLY OVER		
☆JIM REEVES-RCA Victor-8625	81	—
79 TICKLE ME (EP)		
☆ELVIS PRESLEY- RCA Victor-EPA 4383	—	—
80 EVE OF DESTRUCTION		
☆BARRY McGUIRE-Dunhill-4009	—	—
81 CANADIAN SUNSET		
☆SOUNDS ORCHESTRAL-Parkway-958	83	90
82 WHO'LL BE THE NEXT IN LINE		
☆KINKS-Reprise-0366	98	—
83 MOONLIGHT AND ROSES		
☆VIC DANA-Dolton-309	100	—
84 I'M ALIVE		
☆HOLLIES-Imperial-66119	87	—
85 ACTION		
☆FREDDIE CANNON- Warner Bros.-5645	—	—
86 IT'S A MAN DOWN THERE		
☆G. L. CROCKETT-Four Bros.-445	—	—
87 DANGER HEARTBREAK DEAD AHEAD		
☆MARVELETTES-Tamla-54120	—	—
88 GIVE ALL YOUR LOVE TO ME		
☆GERRY & PACEMAKERS-Laurie-3313	—	—
89 THE SWEETHEART TREE		
☆HENRY MANCINI-RCA Victor 8624	90	92
90 SUMMER WIND		
☆WAYNE NEWTON-Capitol-5470	93	—
91 HE'S GOT NO LOVE		
☆SEARCHERS-Kapp-686	92	—
92 WHERE WERE YOU WHEN I NEEDED YOU		
☆JERRY VALE-Columbia-43337	95	—
93 OUT IN THE SUN		
☆BEACH NUTS-Bang-504	91	94
94 I'VE CRIED MY LAST TEAR		
☆O'JAYS-Imperial-66121	97	—
95 WHAT ARE WE GOING TO DO		
☆DAVID JONES-Colpix-784	100	—
96 I LIVE FOR THE SUN		
☆SUNRAYS-Towers-148	96	—
97 MY GIRL SLOOPY		
☆LITTLE CAESAR & CONSULS- Mala-512	—	—
98 SUMMER WIND		
☆ROGER WILLIAMS-Kapp-KJB55	99	—
99 HANG ON SLOOPY		
☆McCOYS-Bang-506	—	—
100 YOU'RE GONNA MAKE ME CRY		
☆O. V. WRIGHT-Back Beat-548	—	—
100 SUMMER NIGHTS		
☆MARIANNE FAITHFULL- London-9780	—	—

ALPHABETIZED TOP 100 (INCLUDING PUBLISHERS AND LICENSEES)

Action (Screen Gems, Cal. BMI)	85
Agent OO Saul (Myta BMI)	58
A Little Bit Of Heaven (TB BMI)	57
A Little You (Leeds ASCAP)	50
All I Really Want To Do (Witmark ASCAP)	9
Annie Fannie (Shorow & Burdette, Flomar, BMI)	71
Baby I'm Yours (Blackwood BMI)	13
California Girls (Sea Of Tunes BMI)	7
Canadian Sunset (Vague BMI)	81
Cara Mia (Lea Feist ASCAP)	22
Calours (Southern ASCAP)	76
Danger Heartbreak Dead Ahead (Jobete, BMI)	87
Don't Just Stand There (Bernarrs BMI)	6
Down In The Boondocks (Lowery BMI)	10
Easy Question (Elvis Presley BMI)	56
Eve Of Destruction (Trausdale BMI)	80
Fly Me To The Moon (Almanac ASCAP)	73
Give All Your Love To Me (Pacemaker BMI)	88
Hank On Sloopy (Melin BMI)	99
Heart Full Of Soul (Miller ASCAP)	30
He's Got No Love (Duchess BMI)	91
Help (Maclean BMI)	8
Here Am I (United Artists ASCAP)	85
Hold Me, Thrill Me (Mills ASCAP)	12
Houston (Criterion ASCAP)	43
Hung On You (Screen Gems-Cal. BMI)	45

I Can't Help Myself (Jobete BMI)	25
I Don't Wanna Lose You Baby (Blackwood BMI)	59
I Got You Baby (Five West-Cotillion BMI)	1
I Like It Like That (Tune-Kel BMI)	16
I Live For The Sun (Sea Of Tunes BMI)	96
I Want Candy (Web IV, Grand Canyon BMI)	15
If I Didn't Love You (Metric BMI)	68
I'll Always Love You (Jobete BMI)	47
I'm A Fool (Atlantic BMI)	19
I'm Alive (Camelback-Mountain ASCAP)	84
I'm A Happy Man (United Artists BMI)	67
I'm Henry The VIII (Miller ASCAP)	4
In Crowd (American BMI)	44
In The Midnight Hour (Catillion-East BMI)	37
Is It Really Over (Tuckahoe BMI)	78
It Ain't Me Babe (M. Witmark ASCAP)	46
It's A Man Down There (Fairshake BMI)	86
It's Gonna Be Fine (Screen Gems, Cal. BMI)	66
It's Gonna Take A Miracle (South Mt. BMI)	63
It's The Same Old Song (Jobete BMI)	11
It's Too Late, Baby, Too Late (Ply, Weiss BMI)	70
I've Cried My Last Tear (Minit BMI)	84
Ju Ju Hand (Beckie BMI)	31
Like A Rolling Stone (M. Witmark ASCAP)	17
Looking Thru The Eyes Of Love (Screen Gems Cal. BMI)	33

Marie (Irving Berlin ASCAP)	48
Maan Over Naples (Raasevelt BMI)	51
My Girl Sloopy (Picturetone, Melin BMI)	97
Maanlight & Roses (Daniels ASCAP)	83
New Orleans (Rockmasters BMI)	36
No Pity In The Naked City (Merrimac BMI)	61
Nothing But Heartaches (Jobete BMI)	21
One Dyin' And A Buryin' (Tree BMI)	38
One Step At A Time (Flomar BMI)	53
Only These In Love (Brown BMI)	72
Oawee, Oowee (Leeds ASCAP)	93
Oawee, Oowee (Leeds ASCAP)	77
Pappa's Got A Brand New Bag (Lais BMI)	18
Pretty Little Baby (Jobete BMI)	34
Ride Your Pony (Jobe BMI)	49
Sad, Sad Girl (Stilran, Dandelion BMI)	64
Satisfaction (Immediate BMI)	3
Save Your Heart For Me (Geld, Udell, Purchase ASCAP)	5
Seventh Son (Arc BMI)	54
Shake & Fingerpop (Jobete BMI)	52
Simpel Gimpel (MRC BMI)	74
Since I Last You Baby (Jobete BMI)	35
Sittin' In The Park (Chevis BMI)	62
Sugar Dumpling (Kags BMI)	42

Summer Nights (Sea Lark BMI)	100
Summer Wind (M. Witmark)	90, 98
Sunshine, Lollipops & Rainbows (Hansen ASCAP)	32
Sweetheart Tree (East-Hill ASCAP)	75, 89
Take Me Back (St. Mountain BMI)	23
Theme From A Summer Place (M. Witmark ASCAP)	29
Tickle Me (EPO) (Various)	79
To Know You Is To Love You (Hilliary BMI)	39
Taa Many Rivers (Hill & Range BMI)	27
Track Of My Tears (Jobete BMI)	20
Unchained Melody (Frank ASCAP)	14
We Gotta Get Out Of This Place (Screen Gems-Cal. BMI)	65
What Are We Going To Do (Screen Gems, Cal. BMI)	95
What's New Pussycat? (United Artists ASCAP)	2
Who'll Be The Next In Line (Jay Boy BMI)	82
Yes I'm Ready (Dandelions-Stillhan BMI)	41
You Tell Me Why (Taracrest BMI)	40
You Turn Me On (Burdette BMI)	55
You Were On My Mind (M. Witmark ASCAP)	24
You Better Go (St. Mountain BMI)	28
You'd Better Come Home (Duchess BMI)	69
You're Gonna Make Me Cry (Dan BMI)	100
You're My Baby (Screen Gems, Cal. BMI)	60



Fortune: We see a very bright future
for this record... *

The Fortunes

**“YOU’VE GOT
YOUR
TROUBLES”**

9773



**PRESS
records**



THE AMERICAN *LONDON* GROUP

* We're really not so smart... it's already
the fastest selling record in England,
and
AN INSTANT SMASH U.S.A. !

INDEX

THIS WEEK'S RECORD TRADE NEWS BEGINS ON PAGE 168

DIRECTORY INDEX

	Page		Page
Album Jacket Manufacturers	118	Printers & Lithographers	153
ASCAP Publishers	122-136	Polyethylene Bag Manufacturers	113
BMI Publishers	138-153	Rack Jobbers	114-117
DJ Poll Results (Big 3 Pop Winners)	14	Record Carrying Cases	152
DJ Poll Results (Big 3 Country Winners)	158 & 160	Record Distributors	56-84
DP Poll Results (Country Music)	162	Record Exporters	110
DJ Poll Results (Past Winners)	26	Record Manufacturers	28-54
DJ Poll Results (Pop)	16, 20, 24	Record Platers	95
Golden Albums	96	Record Pressers	86-94
Machine Shops	117	Record Promotion & Publicity Officers	111
Manufacturers of Cleaners, Cloths & Brushes	136	Record Sleeve Manufacturers	118
Material Milling Plants (Biscuits)	95	Recording Studios	119-121
Million Sellers	98-102	SESAC Publishers	154
One-Stops	104-110	Trade Associations	118
Phono Needle Manufacturers	153		

INTERNATIONAL INDEX

Aden	5	Ecuador	46	Japan	57	Portugal	104, 111
Afghanistan	5	El Salvador	46	Jordan	69	Qatar	111
Angola	5	Ethiopia	46	Kenya	69, 85	Rhodesia (South)	111
Argentina	83	Fiji Islands	46	Korea	85, 86	Rumania	111
Australia	68	Finland	123	Kuwait	86	Senegal	111
Austria	5	Formosa	46	Lebanon	86	South Africa	87, 111, 115
Bahamas	5	France	48	Liberia	86	Spain	116
Bahrein	5	Germany	32	Libya	86	Sudan	115
Belgium	76	Ghana	46	Malagasy (Madagascar)	86	Sweden	119
Bermuda	5	Great Britain	4	Malaysia	86	Switzerland	92, 115, 118
Bolivia	5	Greece	46	Malta	86	Syrian Arab Republic	118
Brazil	88	Greenland	46	Mexico	112	Thailand	118
Bulgaria	5	Guatemala	46	Mongolian People's Republic	86	Togo	118
Burma	5	Haiti	46	Morocco	86	Trinidad	118
Canada	105	Holland	70	New Zealand	90	Trucial States	118
Ceylon	5	Honduras	46	Nicaragua	90	Tunisia	118
Chile	5, 22	Hong Kong	46	Nigeria	90	Turkey	126
China	22	Hungary	69	Norway	122	Uganda	126
Colombia	23	Iceland	69	Pakistan	104	United Arab Republic	126
Congo	46	India	69	Panama	104	Uruguay	126
Costa Rica	46	Indonesia	69	Paraguay	104	U.S.S.R.	126
Cuba	46	Israel	69	Peru	104	Venezuela	126
Cyprus	46	Italy	95	Philippines	104	Vietnam (Democratic Republic of)	126
Czechoslovakia	46	Ivory Coast	69	Poland	104	Vietnam	126
Dahomey	46	Jamaica	69			Western Samoa	126
Denmark	124					Yugoslavia	126
Dominican Republic	46						

WEEKLY FEATURE INDEX

Album Plans	194	Radio Active Chart	192
Album Reviews	184, 188, 190	R&B Top 50	196
Bio's for Deejays	170	Record Ramblings	198, 200
Country Reviews	156-157	Pop Singles Reviews	172, 174, 176, 178
Country Roundup	164	Sure Shots	206
Country Top 50	166	Top 100 Albums	183
Juke Box Ops Guide	196	Top 100 Singles	6
Looking Ahead (Albums)	183	Top 30 Country Albums	166
Looking Ahead (Singles)	180	Top 100 Labels	132
Platter Spinner Patter	170		

3,186,932

IS THE HIT NUMBER FOR 1965

It's the patent number just awarded us for The Audiomatic Process, the system that makes the best all-nickel masters, mothers and stampers—and makes them fastest. When you're ready to process your next hit number, remember Audio Matrix patent number 3,186,932.

AUDIO MATRIX, INC. / 915 WESTCHESTER AVENUE / BRONX 59, NEW YORK • 212 LU 9-3500
Producers of record plates and record plating equipment/ CABLE ADDRESS AUDIOMATIC

RUGGED, VERSATILE, LONG-LASTING

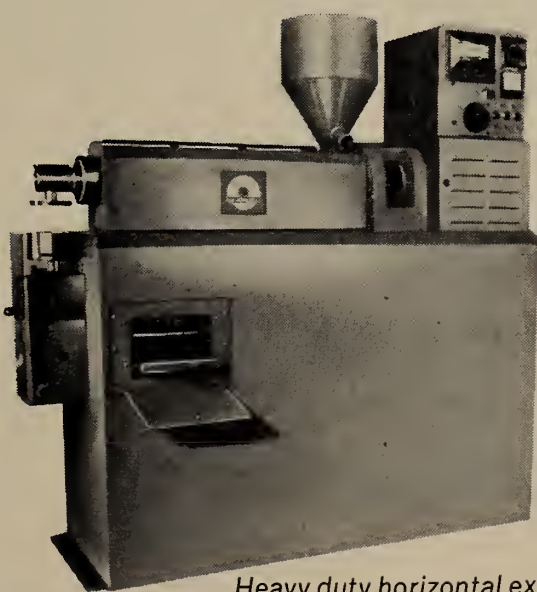

Heavy duty horizontal extruder



Console model extruder

Audiomatic compounders are built to work hard for years. They handle pure or filled material in any form—dry blend, pellets or granular. They extrude a neat round biscuit with a hole in the middle. There are no messy spaghetti strands.

Our console model* is an engineering beauty, less than three feet high. Our high capacity horizontal model is a real work horse that can serve two or more LP presses.

No wonder they are the choice of leading pressing plants on four continents. Call or write today for more information.

AUDIOMATIC CORPORATION / 915 WESTCHESTER AVENUE / BRONX 59, NEW YORK • 212 LU 9-3500
*Equipment engineers and consultant to the record industry/ CABLE ADDRESS AUDIOMATIC/ *Patent Pending*

*Heartfelt Appreciation To All Our
Friends Through Out The World Who
Have Helped Me Through The Years*



DEL SHANNON

CURRENT HIT

“MOVE IT ON OVER”

AMY 937

EXCLUSIVELY ON

AMY RECORDS

CURRENT ALBUM

**“ONE THOUSAND SIX HUNDRED SIXTY
ONE SECONDS WITH DEL SHANNON”**



AMY 8006

PERSONAL MGMT. ARTISTS INC. DETROIT, MICH.

MUSIC (INTERNATIONAL) — Part 2

A		E		MGM Records—USA 80, 81		Seith, August—Germany 42	
ABC—Paramount—USA	30	Eastern Music—Japan	62	Microfon—Argentina	85	Shapiro Bernstein—England	22
Aberbach—England	23	EM&I—Brazil	89	Mills Music—England	22	Shinko Music—Japan	66
Aberbach—Germany	32	Ember Records—England	22	Millwich Ltd.—England	25	Shin-nichi Promotions—Japan	66
Accord—Germany	45	Emerald Records—Ireland	18	Multitone A/S—Denmark	124	Show Records—Belgium	79
Acuff-Rose	80, 81	EMI—England	6, 7, 8, 9	Musart Records—Mexico	112	Sicamericana—Argentina	84
Airdisc—USA	18, 38, 77, 94, 119, 124	Epic—USA	91	Music Canada—Canada	110	Siegel, Ralph Maria—Germany	37
Ale Nicky—Argentina	86	Essex, Musikforlaget—Sweden	119	Musifon—Japan	66	Smart Publishers—Argentina	84
Allied Record Corp.—Canada	108	F		Musikvertrieb AG—Switzerland	93	Sobedi—Belgium	76
Altona—Holland	73	Feltz, Kurt—Germany	38	N		Solomon, Philip—England	27
Ambassador Music—England	23	Fermata—Argentina—Brazil—Mexico	88	National Record Library—USA	44	Sonet Grammofon—Sweden	120
American Songs—Sweden	122	Festival—France	48	Negrann—Holland	74	Sonora—Sweden	119
Amagon—Holland	70	Fields, Harold	23	Neumann—Argentina	84	Sparta Music—England	29
Anvers Radio—Belgium	79	Francis, Day & Hunter—England	14	New Orient Music—Japan	66	Sparton Records—Canada	108
Apollo Music—England	15	G		Nichion—Japan	59	Stockholms Musikproduktion—Sweden	122
Arc Sound Ltd.—Canada	109	Gehrmans—Sweden	122	Nippon Columbia Pub—Japan	66	Stone, Robert—Canada	111
Ardmore Beechwood—England	28	Gerig Musikverlage—Germany	41	Nippon Crown—Japan	60	Suissei-Sha—Japan	64
Arends, Paul—Germany	40	Globe Music—Belgium	78	O		Surco Industrias—Argentina	86
Argo Record—England	21	Good Music—England	29	Odeon—Sweden	121	Sweden Music—Sweden	120
Ariston Records—Italy	95	H		Ongaku-No-Tomo—Japan	64	T	
B		Hodes, Leonard—USA	77	Orbisron, Roy	80, 81	Teichiku Records—Japan	58
Barclay Records—France	55	I		Orfeon Videovox—Mexico	112	Teldec—Germany	39
Basart—Holland	73	Idee Music—Germany	42	P		Tea Music—Japan	64
Belinda—Holland	73	Internationale Muziek—Holland	73	Palette Benelux, USA	77	Toby Music—England	21
Belmont Musikverlag—Germany	43	J		Passé-Partout & Dancing—Belgium	79	Tono—Denmark	124
Benjamins, Arne—Norway	123	James Music Ltd., Dick	20	Peer Southern Organization	19	Toshiba Music—Japan	61
Bens—Belgium	78	K		Peter Maurice—England	24	Tournier—France	54
Bourne Music—England	22	Keith Prouse—England	24	Pick Records—Switzerland	94	Transatlantic—England	21
Bovema—Holland	71	King Records—Japan	63	Philips—England	13	Transatlantic Musikverlag—Germany	45
Bron, Sydney—England	22	Kluger, Jean—Belgium	79	PJO—Finland	123	Trans Canada—Canada	110
Buddle, Rolf—Germany	42	Korn, Julio—Argentina	85	Plum, Peter—Belgium	76	Turicaphon AB—Switzerland	92
Burlington-Palace—England	24	L		Poser, Freddie—England	23	Tutti—France	53
C		Lagos—Argentina	84	Publi-Show—Belgium	79	U	
CAAM—Italy	98, 99	Laval Records—Canada	109	Pye Records—England	16, 17	United Artists Music—England	25
Campbell Connelly—England	25	Lindon Records—England	21	Q		V	
Capital Records of Canada—Canada	110	London Records, Canada	105	Quality Records—Canada	111	Vergara—Spain	117
Capriccio—Germany	45	M		R		Verve—USA	75
CAP—Japan	60	Marbot—Germany	43	RCA Victor—Argentina	83	Victor Co.—Japan	57
CBS Records	2, 3	Marquis Ent.—England	29	RCA Victor France	56	Victor Pub.—Japan	62
CBS Columbia Records—Canada	109	Meisel, Will—Germany	44	RCA Victor—Japan	57	Victor, RCA—Argentina	83
CBS Columbia Records—Spain	116	Mellin Ltd., Robert—England	25	RCA Victor—Mexico	113	Victor, RCA—Canada	106
CBS—Argentina	83	Melodisc Records—England	25	RCA Victor—USA	67	Victor, RCA—France	56
CBS Nippon Columbia—Japan	59	N		Rozenblit Ltds.—Brazil	89	Victor, RCA—Mexico	113
Chappell—England	23	Rozenblit Ltds.—Brazil	89	S		Victor, RCA—USA	67
City Music—England	25	Scan-Disc—Sweden	121	Reuter & Reuter—Sweden	122	Vista—USA	47
Clan Celantano—Italy	103	Scandia Music Co.—Finland	123	Ricordi, Dischi—Italy	101	Vogue, Disques—France	49, 50, 51, 52
CLR—Holland	72	O		Ri-Fi Record Co.—Italy	100	W	
Coda, Edition—Switzerland	94	Rozenblit Ltds.—Brazil	89	Rodeo Records, Ltd.—Canada	109	W & G—Australia	68
Command Records—USA	31	P		Rogers, Noel—England	25	Watanabe Prod.—Japan	65
Comoro—Mexico	114	Rozenblit Ltds.—Brazil	89	Ronnex Records—Belgium	78	Watanabe Music Pub.—Japan	65
Crown Music—Japan	60	S		Rozenblit Ltds.—Brazil	89	Welt, Melodie Det.—Germany	40
Cupol—Sweden	122	Scan-Disc—Sweden	121	T		World Music—Belgium	78
D		Scandia Music Co.—Finland	123	Zafira—Spain	116	Z	
Decca—England	11	M		Zen-On—Japan	64	Z	
Decca—France	56	Marvel Mfg.	54	S		Z	
DeLuxe, Fernand—Belgium	79	Midway Mfg.	75	Schmelke	11	Z	
Delyse—England	18	Miller-Newmark	43	Scopitone U.S.A.	73	Z	
DeGG—England	29	Mondial International	8 and 9	Seeburg Corp.	29	Z	
DeGG—Germany	33, 34, 35	Monroe Coin Machine Exchange	76	Serv-O-Motic	9	Z	
De Jockey Records—Argentina	85	M.O.N.Y.	45	Shaffer	44	Z	
Disco Music—Belgium	77	Irving Morris Dist.	57	Simon Dist. Co.	45	Z	
Disorium Records—Italy	97	Mike Munves Corp.	5	Southern Automatic	19	Z	
E		Musical Distributors	52	Southeastern Dist. Co.	48	Z	
E		G		State Sales & Service	20	Z	
E		D. Gottlieb & Co.	77	Struve Dist. Co.	15	Z	
E		General Vending Co.	22	Sun-Glo	11	Z	
E		Globe Dist. Co.	6	Sutherland Dist.	50	Z	
E		Gold Medal	70	T		Z	
E		Greco Bros. Dist. Co.	59	Taito Trading	16	Z	
E		H		Trimount Automatic Sales	16	Z	
E		Harby	22	Tulsa Dist. Co.	53	Z	
E		Hastings Dist. Co.	42	U		Z	
E		H. Z. Vending Co.	4	United Inc.	20	Z	
E		Hawkins	45	Urban Industries	22	Z	
E		I		U.S. Billiards Co.	33	Z	
E		I.C.M.O.A.	42	V		Z	
E		International Mfg.	55	Valley Sales	35	Z	
E		Intersphere, Inc.	49	VASCO	76	Z	
E		J		W		Z	
E		R. F. Jones Dist.	14	Westchester Operators Guild	52	Z	
E		K		Williams Mfg.	Cover Three	Z	
E		The Irving Kaye Co.	31	World Wide Dist.	44	Z	
E		L		The Wurlitzer Co.	418	Z	
E		Loke City Dist.	44	Z		Z	
E		Liberman Dist. Co.	20	Z		Z	
E		Lipsky Distributors	22	Z		Z	
E		London Dist. Co.	43	Z		Z	
E		Royal Dist. Co.	54	Z		Z	

COIN MACHINES & VENDING — Part 3

A		F		M		S	
1 Record Sales	42	Fischer Mfg.	21	Marvel Mfg.	54	Schmelke	11
Active Amusement Co.	45	Frantz	5	Midway Mfg.	75	Scopitone U.S.A.	73
Advance Automatic	22	G		Miller-Newmark	43	Seeburg Corp.	29
Al Tech	53	D. Gottlieb & Co.	77	Mondial International	8 and 9	Serv-O-Motic	9
American Shuffleboard Co.	37	General Vending Co.	22	Monroe Coin Machine Exchange	76	Shaffer	44
Archie Anderson Dist.	54	Globe Dist. Co.	6	M.O.N.Y.	45	Simon Dist. Co.	45
M.O. Fla.	42	Gold Medal	70	Irving Morris Dist.	57	Southern Automatic	19
Las Dist. (of Chicago)	48	Greco Bros. Dist. Co.	59	Mike Munves Corp.	5	Southeastern Dist. Co.	48
Las Dist. (of Pittsburgh)	50	H		Musical Distributors	52	State Sales & Service	20
Lomatique	12 and 13	Harby	22	N		Struve Dist. Co.	15
B		Hastings Dist. Co.	42	National Coin Machine Ex.	76	Sun-Glo	11
Banner Specialty	52	H. Z. Vending Co.	4	National Rejectors, Inc.	68 and 69	Sutherland Dist.	50
Billy Mfg.	39	Hawkins	45	National Shuffleboard	52	T	
B.H. Belam	7	I		New Orleans Novelty	5	Taito Trading	16
Benchi Velo	62 and 65	I.C.M.O.A.	42	Northwest Sales	6	Trimount Automatic Sales	16
C		International Mfg.	55	Nova Apparate	17	Tulsa Dist. Co.	53
Cameron Dist.	57	Intersphere, Inc.	49	N.Y.S.C.M.A.	43	U	
Chicago Dynamic	417	J		O		United Inc.	20
Cleveland Coin Machine Ex.	38	R. F. Jones Dist.	14	Operators Sales Corp.	76	Urban Industries	22
C.I.N.	59	K		P		U.S. Billiards Co.	33
Corman Electronic	43	The Irving Kaye Co.	31	Peach State Vending	11	V	
Columbia Records	47	L		Phonograph Service Corp.	43	Valley Sales	35
D		Loke City Dist.	44	Phonographic Equipment	7	VASCO	76
D & R Industries	45	Liberman Dist. Co.	20	Pioneer & H. C. Vending	16	W	
Dals Dist. Co.	46	Lipsky Distributors	22	Protocision	53	Westchester Operators Guild	52
Darte Dist. Co.	4	London Dist. Co.	43	Purveyor	45	Williams Mfg.	Cover Three
Dime Games Div.	51	Royal Dist. Co.	54	P.Z.P. Inc.	74	World Wide Dist.	44
Doball	45	M		R		The Wurlitzer Co.	418
E		Roanoke Vending Exchange	60	Rock-Ola Mfg.	Cover 4	Z	
Fire Coin Machine Exchange	21	Rock-Ola Mfg.	Cover 4	David Rosen, Inc.	27 and 54	Z	
Green Novelty	18	Rowe AC Mfg.	25, 71 and 79	Ruffler & Walker	20	Z	

CONGRATULATIONS AND THANK YOU FROM:

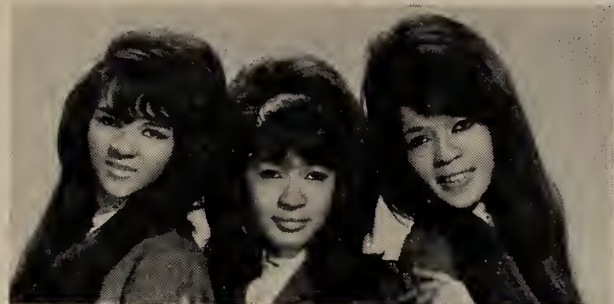

THE RONETTES



THE RIGHTEOUS BROTHERS



DARLENE LOVE & THE BLOSSOMS



Division of PHIL SPECTOR PRODUCTIONS

— "TRULY REPRESENTATIVE OF THE TIMES"

THE BIG THREE

WINNERS IN EACH CATEGORY OF CASH BOX' DISK JOCKEY POLL

MOST PROGRAMMED RECORD

1. Downtown—Petula Clark—Warner Bros.—Leeds (ASCAP)
2. A Hard Day's Night—The Beatles—Capitol—Unart, Maclen (BMI)
3. Girl From Ipanema—Stan Getz & Astrud Gilberto—Verve—Duchess (BMI)

MOST PROGRAMMED ALBUM

1. Beatles '65—The Beatles—Capitol
2. A Hard Day's Night—The Beatles—United Artists
3. People—Barbra Streisand—Columbia

MOST PROGRAMMED MALE VOCALIST

1. Elvis Presley
2. Andy Williams
3. Frank Sinatra

MOST PROMISING MALE VOCALIST

1. Tom Jones
2. Frankie Randall
3. Jack Jones

MOST PROGRAMMED FEMALE VOCALIST

1. Barbra Streisand
2. Brenda Lee
3. Petula Clark

MOST PROMISING FEMALE VOCALIST

1. Petula Clark
2. Marianne Faithfull
3. Bobbi Martin

MOST PROGRAMMED VOCAL GROUP

1. The Beatles
2. Herman's Hermits
3. The Supremes

MOST PROMISING MALE VOCAL GROUP

1. The Seekers
2. Herman's Hermits
3. The Byrds

MOST PROGRAMMED ORCHESTRA

1. Henry Mancini
2. Bert Kaempfert
3. Billy Vaughn

MOST PROMISING INSTRUMENTALIST

1. Horst Jankowski
2. Derek & Ray
3. Willie Mitchell

MOST PROGRAMMED INSTRUMENTALIST

1. Al Hirt
2. The Ventures
3. Peter Nero

MOST PROMISING ORCHESTRA

1. Sounds Orchestral
2. Horst Jankowski
3. Herb Alpert & The Tijuana Brass

THANK YOU!

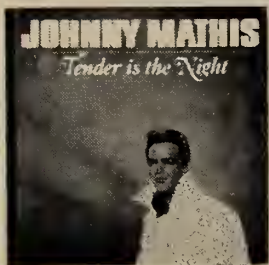
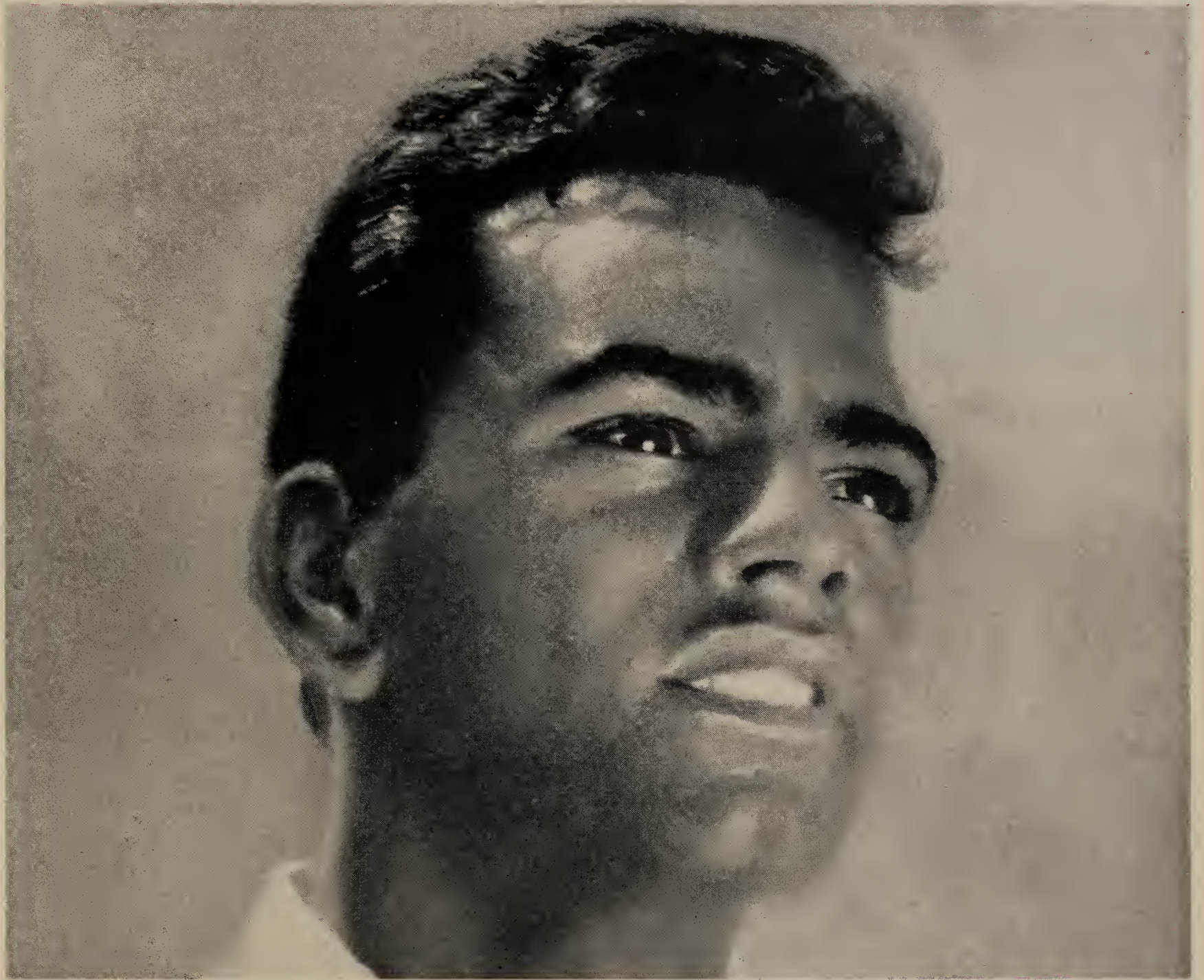

TENDER IS THE NIGHT
MG 20890/SR 60890



THE WONDERFUL WORLD
OF MAKE-BELIEVE
MG 20913/SR 60913



THIS IS LOVE
MG 20942/SR 60942



OLÉ
MG 20988/SR 60988



LOVE IS EVERYTHING
MG 20991/SR 60991



THE YOUNG AMERICANS
PRESENTED BY
JOHNNY MATHIS
MG 21023/SR 61023



Produced by Global Records





Congratulations to
Cash Box
on its
23rd Anniversary

Jack Jones

P.S. My sincerest thanks to the nation's DJ's.

Current releases

"My Kind of Town"
LP — (KL-1433/KS-3433)

**"Seein' The Right
Love Go Wrong"**
b/w
"Travellin' On"
Single — (K-672)

Public relations: John Springer Associates, Inc., N.Y.
Frank Liberman and Associates, L.A.

Management: Nick Sevano

Musical conductor: Doug Talbert

Personal appearances:

Direction



Television and Motion Pictures:



WILLIAM MORRIS AGENCY, INC.

CASH BOX 1965 DJ POLL RESULTS

The following poll results are based on a survey of 4000 disk jockeys in America, and cover, where applicable, a 12 month period ending July 1. Winners in each category are stated as compiled; therefore some artists may appear in "most programmed" and "most promising" categories. Each disk jockey determined those categories in which disk jockeys were to be represented.

SINGLES PLAYED MOST

1. DOWNTOWN—PETULA CLARK—WARNER BROS.
2. HARD DAY'S NIGHT—THE BEATLES—CAPITOL
3. GIRL FROM IPANEMA—STAN GETZ-ASTRUD GILBERTO—VERVE

You've Lost That Loving Feeling—The Righteous Bros.—Philips
Mrs. Brown You've Got A Lovely Daughter—Hermin's Hermits—MGM
King Of The Road—Roger Miller—Smash
Where Did Our Love Go?—The Supremes—Motown
People—Barbra Streisand—Columbia
Hello, Dolly—Louis Armstrong—Kapp
Oh, Pretty Woman—Roy Orbison—Monument
Dear Heart—Jack Jones—Kapp; Henry Mancini—RCA Victor; Andy Williams—Columbia
I Want To Hold Your Hand—The Beatles—Capitol
Red Roses For A Blue Lady—Bert Kaempfert—Decca
Eight Day's A Week—The Beatles—Capitol
We'll Sing In The Sunshine—Gale Garnett—RCA Victor
This Diamond Ring—Gary Lewis and The Playboys—Liberty
Cast Your Fate To The Wind—Sounds Orchestral—Cameo/Parkway
Dang Me—Roger Miller—Smash
Everybody Loves Somebody—Dean Martin—Reprise
Mr. Lonely—Bobby Vinton—Epic
Stop! In The Name Of Love—The Supremes—Motown
Baby The Rain Must Fall—Glenn Yarbrough—RCA Victor
Hush, Hush, Sweet Charlotte—Patti Page—Columbia
A Walk In The Black Forest—Horst Jankowski—Mercury
I'm Telling You Now—Freddie and The Dreamers—Tower
I Know A Place—Petula Clark—Warner Bros.
She's A Woman—The Beatles—Capitol
More—Kai Winding—Verve
Ringo—Lorne Greene—RCA Victor
I Can't Help Myself—The Four Tops—Motown

ALBUMS PLAYED MOST

BEATLES '65 70—CAPITOL
A HARD DAY'S NIGHT—BEATLES—UNITED ARTISTS
PEOPLE—BARBRA STREISAND—COLUMBIA
Introducing Hermin's Hermits—MGM
Sinatra—Basie—Reprise
Beatles For Sale—Capitol
You've Lost That Lovin' Feeling—Righteous Bros.—Philips
Getz—Gilberto—Verve
Beach Boys Today—Capitol
Dear Heart—Andy Williams—Columbia
Something New—Beatles—Capitol
Sugar Lips—Al Hirt—RCA Victor
Beatles Songbook—Hollyridge Strings—Capitol
Pink Panther—Henry Mancini—RCA Victor
How Glad I Am—Wilson—Capitol
Mary Poppins—Soundtrack—Vista
Dear Heart—Henry Mancini—RCA Victor
Meet The Beatles—Capitol
Goldfinger—Soundtrack—United Artists
Pearly Shells—Billy Vaughn—Dot
Call Me Irresponsible—Andy Williams—Columbia
Honey In The Horn—Al Hirt—RCA Victor
Beatles VI—Capitol
Cotton Candy—Al Hirt—RCA Victor
Wonderful World Of Andy Williams—Columbia
3rd Barbra Streisand Album—Columbia
Dang Me-Chug-A-Lug 5 (3)—Roger Miller—Smash
Rolling Stones—London
From Hello, Dolly! To Goodbye Charlie—Bobby Darin—Capitol
Another Hit Album—Billy Vaughn—Dot
Wives And Lovers—Jack Jones—Kapp

MALE VOCALISTS MOST PROGRAMMED

ELVIS PRESLEY	Steve Lawrence
ANDY WILLIAMS	Robert Goulet
FRANK SINATRA	Gene Pitney
Roger Miller	Bobby Goldsboro
Bobby Vinton	Al Martino
Dean Martin	Ronnie Dove
Jack Jones	Jim Reeves
Nat King Cole	John Gary
Tony Bennett	Perry Como
Roy Orbison	Johnny Mathis
Johnny Rivers	Frankie Randall
	Glenn Yarbrough
	Jerry Vale

ăn'nu·al *adj.* occur-
ring or returning once a year:
like Cash Box Annual.



suc·cĕss' *n.* favorable
performance or achievement:
*like the success these labels
achieve every day, annually!*





ALLEN & ROSSI
MARC ALLEN
THE ARBORS
SIL AUSTIN
BROOK BENTON
THE BITTER END SINGERS
DAVID CARROLL
THE CHALFONTES
HERMAN CLEBANOFF
JAMES CRAWFORD
XAVIER CUGAT
THE DEBS
BONNIE DOBSON
FATS DOMINO
ANTAL DORATI
ROY DRUSKY
DAVE DUDLEY
BILLY ECKSTINE
LOLA FALANA
FREDERICK FENNELL
FRANK & TONY
FREDDIE AND THE DREAMERS
ERROLL GARNER
LEMME B. GOOD
LESLEY GORE
CARL HALL
BARBARA HARRIS
MARGIE HENDRIX
JUDY HENSKE
THE HONDELLS
EDDY HOWARD
MARY HUNT
BYRON JANIS
HORST JANKOWSKI
GEORGE JONES
QUINCY JONES
ABBE LANE
LYNN LONG
MOMS MABLEY
HUGH MASEKELA
RICKY MASON
JOHNNY MATHIS
DANNY MEEHAN
MILAN
THE MITCHELL TRIO
KAREN MORROW
NICHOLS & MAY

PATTI PAGE
THE PARIS SINGERS
THE PLATTERS
RAFAEL PUYANA
WALTER RAIM
THE ROBIN HOODS
JOHNNY ROBINSON, JR.
ALBERTO ROCHI
JULIE ROGERS
LYN ROMAN
CELEDONIO ROMERS & SONS
THE SINNERS
THE SKUNKS
THE SMOTHERS BROTHERS
JANOS STARKER
THE SUGAR HILL FOUR
HENRYK SZERYNG
CHARLES TAYLOR
EDWARD B. TOWNSEND
LEROY VAN DYKE
DAVE VAN RONK
SARAH VAUGHAN
JERRY WALLACE
DINAH WASHINGTON
THE WAYWARD WINDS
FARON YOUNG
TIMI YURO



CLAUDIO ARRAU
TERESA BREWER
THE CONCERTGEBOUW ORCHESTRA
ROBERT FARNON
THE FLAMINGOS
THE 4 SEASONS
JACQUELINE FRANCOIS
ARTHUR GRUMIAUX
BRIAN HYLAND
IAN AND THE ZODIACS
I MUSICI
LESTER LANIN
MICHAEL LEGRAND
YVES MONTAND
PIERRE MONTEUX
ESTHER OFARIM
EDITH PIAF
SVIATOSLAV RICHTER
JOHNNY SEA
HARRY SECOMBE
THE SERENDIPITY SINGERS
NINA SIMONE
GERALD SOUZAY
DUSTY SPRINGFIELD
THE SWINGLE SINGERS
JOAN TOLIVER
JIMMY VELVET
THE VIENNA CHOIR BOYS
THE WOOD SISTERS



BOB BECKHAM
 BOBBY BYRD
 THUMBS CARLLILE
 PETE DRAKE
 THE FORTUNE COOKIES
 JON HENDRICKS
 BILL JUSTIS
 JERRY KENNEDY
 JERRY LEE LEWIS
 BROWNIE McGHEE
 ROGER MILLER
 CHARLIE RICH
 THE RON-DELS
 SONNY TERRY
 FRANKIE VALLI
 THE WALKER BROTHERS



OSCAR BROWN, JR.
 JOHNNY DANKWORTH
 RAL DONNER
 THE ESCORTS
 WAYNE FONTANA
 AND THE MINDBENDERS
 THE LEADERS
 GLORIA LYNNE
 THE MERSEYBEATS
 NANA MOUSKOURI
 MARK MURPHY
 THE PRETTY THINGS



L. C. COOKE
 TONY DIAMOND
 JOYCE KENNEDY
 REGGIE LAMONT
 OTIS LEAVILL
 LITTLE ROSE LITTLE
 SIR MACK RICK
 DEE DEE WARWICK



CANNONBALL ADDERLY
 CHET BAKER
 ART BLAKEY
 CLIFFORD BROWN
 JOHN COLTRANE
 ERIC DOLPHY
 THE DOUBLE SIX OF PARIS
 ROY ELDRIDGE
 DIZZY GILLESPIE
 TERRY GIBBS
 COLEMAN HAWKINS
 EARL HINES
 MILT JACKSON
 ROLAND KIRK
 LES McCANN
 CHARLIE MINGUS
 GERRY MULLIGAN
 OSCAR PETERSON
 THE THREE SOUNDS



JIMMY CLEVELAND
 JOHNNY GRIFFIN
 ART HODES
 DJANGO REINHARDT
 BUDDY RICH

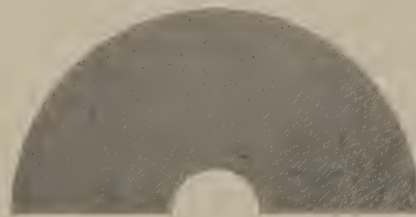



KOPPELMAN-RUBIN ASSOCIATES, INC.

CHARDON MUSIC

FAITHFUL VIRTUE MUSIC
BMI

JUST RELEASED

“DO YOU BELIEVE IN MAGIC” THE LOVIN’ SPOONFUL

KA 201

PRODUCED BY ERIC JACOBSEN

FOR

KOPPELMAN-RUBIN ASSOCIATES

KAMA SUTRA RECORDS

DISTRIBUTED BY MGM

PUBLISHED BY FAITHFUL VIRTUE MUSIC

WRITTEN BY JOHN SEBASTIAN

1650 BROADWAY
NEW YORK, N.Y. 10019
PHONE (212) 765-2682

CASH BOX 1965 DJ POLL RESULTS

FEMALE VOCALISTS MOST PROGRAMMED

BARBRA STREISAND
BRENDA LEE
PETULA CLARK
Connie Francis
Nancy Wilson
Lesley Gore
Eydie Gorme
Peggy Lee
Patti Page
Doris Day

Shirley Ellis
Dusty Springfield
Marianne Faithfull
Astrud Gilberto
Gale Garnett
Vikki Carr
Dionne Warwick
Sandie Shaw
Ella Fitzgerald
Julie Rogers
Mary Wells

VOCAL GROUPS MOST PROGRAMMED

THE BEATLES
HERMIN'S HERMITS
THE SUPREMES
Beach Boys
Ray Conniff Singers
Four Freshmen
New Christy Minstrels

Johnny Mann Singers
Ray Charles Singers
Rolling Stones
Peter, Paul & Mary
Lettermen
Righteous Bros.
Anita Kerr Singers
4 Seasons
Serendipity Singers

ORCHESTRAS MOST PROGRAMMED

HENRY MANCINI
BERT KAEMPFFERT
BILLY VAUGHN
Percy Faith
Lawrence Welk
Sounds Orchestral
Les & Larry Elgart
Si Zentner
Count Basie
Glen Gray
Al Hirt

Hollyridge Strings
Ray Conniff
Glenn Miller
George Martin
Mantovani
Sammy Kaye
Nelson Riddle
Horst Jankowski
John Barry
Andre Kostelanetz
Enoch Light
Boston Pops
Woody Herman

INSTRUMENTALISTS MOST PROGRAMMED

AL HIRT
VENTURES
PETER NERO
Floyd Cramer
Chet Atkins
Pete Fountain
Stan Getz
George Shearing
Roger Williams

Ferrante & Teicher
Horst Jankowski
John Barry
Bill Black
Andre Previn
Boots Randolph
Duane Eddy
Willie Mitchell
Ace Cannon
Jonah Jones
Acker Bilk

UP AND COMING MALE VOCALISTS

TOM JONES
FRANKIE RANDALL
JACK JONES
Ronnie Dove
Roger Miller
Glenn Yarbrough
Johnny Rivers
Gary Lewis
John Gary
Wayne Newton
John Gary
Bobby Goldsboro
Ian Whitcomb

Vic Dana
Donovan
Matt Monroe
Eddie Rambeau
Frankie Fanelli
Trini Lopez
Peter Grady
Dickie Lee
Ed Ames
Lou Rawls
Steve Alaimo
Bob Dylan
Sergio Franchi
Jimmy Roselli
Wayne Fontana
Jimmy Velvet

Follow the dots and see the word with Peter, Paul & Mary



World Tour Itinerary.

- ① Washington, D.C. July 26-Aug. 1st.
- ② Chicago, Illinois. Aug. 9-14.
- ③ Honolulu, Hawaii. Aug. 20-21.
- ④ Sydney, Australia. Aug. 25.
- ⑤ Brisbane, Australia. Aug. 27.
- ⑥ Sydney, Australia. Aug. 28.
- ⑦ Adelaide, Australia. Aug. 31-Sept. 1.

- ⑧ Melbourne, Australia. Sept. 2-3.
- ⑨ Perth, Australia. Sept. 4.
- ⑩ Paris, France. Sept. 10-15.
- ⑪ Leicester, England. Sept. 19.
- ⑫ Birmingham, England. Sept. 22.
- ⑬ Newcastle, England. Sept. 23.
- ⑭ Manchester, England. Sept. 24.
- ⑮ Sheffield, England. Sept. 29.

- ⑯ London, England. Sept. 26.
("Sunday Night At The Palladium" TV Show)
- ⑰ Bristol, England. Sept. 30.
- ⑱ London, England. Oct. 1.
- ⑲ Bournemouth, England. Oct. 2.
- ⑳ Blackpool, England. Oct. 3.
- ㉑ Syracuse, New York. Oct. 8.
(Start of fall season in U.S. — Canada)

International

CONNIE



Favorite

FRANCIS

PERSONAL APPEARANCES:

SEPT. 7—SAHARA—VEGAS
OCT. 9—JAPAN
NOV. 12—BLINSTRUB'S—BOSTON
DEC. 25—DIPLOMAT—MIAMI

CURRENTLY IN PREPARATION. CONNIE'S OWN TV SERIES

FILMS: CURRENTLY IN PRODUCTION:

MGM'S
"WHEN THE BOYS MEET THE GIRLS"

NEW SINGLE RELEASE:
"ROUNDAABOUT"
MGM 13389

EXCLUSIVELY ON:



PERSONAL MANAGEMENT
GEORGE SCHECK
161 WEST 54TH ST.
NEW YORK, N.Y.
(212) JU 6-6767



NEW ALBUM RELEASE

MGM E SE-4298

Thank you DJ's
**SAM THE SHAM
 AND
 THE PHARAOHS**



JU JU HAND

CURRENT SINGLE
 MGM 13364

PERSONAL MGT. PAUL BOMARITO—PO BOX 2085, MEMPHIS, TENN.



**CASH BOX 1965
 DJ POLL RESULTS**

**UP AND COMING
 FEMALE VOCALISTS**

PETULA CLARK	Barbara Mason
MARIANNE FAITHFULL	Lesley Gore
BOBBI MARTIN	Shirley Bassey
Vikki Carr	Shirley Ellis
Jackie De Shannon	Patty Duke
Jody Miller	Gale Garnett
Sandie Shaw	Brenda Holloway
Liza Minelli	Julie Rogers
Barbra Streisand	Dusty Springfield
Astrud Gilberto	Damita Jo
Ethel Ennis	Nancy Wilson
	Carol Stone
	Donna Loren
	Dionne Warwick

**UP AND COMING
 VOCAL GROUPS**

SEEKERS	Bachelors
HERMIN'S HERMITS	Them
BYRDS	Unit 4 + 2
Righteous Bros.	Swingle Singers
Four Tops	Back Porch Majority
Gary Lewis & Playboys	Sam The Sham & The Pharaohs
Supremes	Yardbirds
Chad & Jeremy	Glad Singers
Bitter End Singers	Three D's
Serendipity Singers	Beau Brummels
Freddie & The Dreamers	Zombies
	Wayne Fontana
	J's With Jamie
	Young Americans

**UP AND COMING
 INSTRUMENTALISTS**

HORST JANKOWSKI	Peter Nero
DEREK & RAY	Boots Randolph
WILLIE MITCHELL	Neil Wolfe
Herb Alpert	Cal Tjader
Floyd Cramer	Billy Strange
Sounds Orchestral	John Barry
Travis Wammock	Pete Drake
Ace Cannon	Village Stompers
	Howard Roberts
	Sounds, Inc.

**UP AND COMING
 ORCHESTRAS**

SOUNDS ORCHESTRAL	Claus Ogerman
HORST JANKOWSKI	Bert Kaempfert
HERB ALPERT & THE TIJUANA BRASS	H. B. Barnum
Hollyridge Strings	Matts Olson
Sounds Incorporated	Ernie Heckscher
John Barry	Johnny Keating
	George Martin
	Junior Mance
	Johnny Arturey

***Thank you
 DEEJAYS!***

And thanks to
 Randy Wood

**BILLY
 VAUGHN**

Dot
 RECORDS

"THE NATION'S BEST SELLING RECORDS"

THE BEACH BOYS

*Our sincerest thanks for the fabulous
reception you've given all our albums
and singles . . .*



SUMMER DAYS

(And Summer
Nights!!)

(D) T-2354

★

★

★

AND THESE HOT
CHART ITEMS:

Single Release:

**"HELP ME
RHONDA"**

#5395

★

Album Release:

**"The Beach
Boys Today"**

(D) T-2269

DIRECTION:



WILLIAM MORRIS AGENCY



PAST WINNERS: CASH BOX DJ POLL

MOST PROGRAMMED RECORD

1953—Till I Waltz Again With You—Teresa Brewer
 1954—Secret Love—Doris Day
 1955—Melody Of Love—Billy Vaughn
 1956—Sixteen Tons—Tennessee Ernie Ford
 1957—Don't Be Cruel—Elvis Presley
 1958—All The Way—Frank Sinatra
 1959—Tom Dooley—Kingston Trio
 1960—Mack The Knife—Bobby Darin
 1961—Exodus—Ferrante & Teicher
 1962—Moon River—Henry Mancini
 1963—I Left My Heart In San Francisco—Tony Bennett
 1964—I Want To Hold Your Hand—Beatles
 1965—Downtown—Petula Clark

MOST PROGRAMMED ALBUM

1956—Wee Small Hours—Frank Sinatra
 1957—Songs For Swinging Lovers—Frank Sinatra
 1958—Come Fly With Me—Frank Sinatra
 1959—Come Dance With Me—Frank Sinatra
 1960—Come Dance With Me—Frank Sinatra
 1961—G.I. Blues—Elvis Presley
 1962—Modern Sounds In Country & Western Music—Ray Charles
 1963—First Family—Vaughn Meader
 1964—Meet The Beatles
 1965—Beatles '65—The Beatles

MOST PROGRAMMED MALE VOCALIST

1953—Eddie Fisher
 1954—Eddie Fisher/Perry Como (tie)
 1955—Perry Como
 1956—Perry Como
 1957—Frank Sinatra
 1958—Frank Sinatra
 1959—Frank Sinatra
 1960—Frank Sinatra
 1961—Frank Sinatra
 1962—Frank Sinatra/Elvis Presley (tie)
 1963—Frank Sinatra
 1964—Frank Sinatra
 1965—Elvis Presley

MOST PROGRAMMED FEMALE VOCALIST

1953—Patti Page	1959—Connie Francis
1954—Patti Page	1960—Connie Francis
1955—Rosemary Clooney	1961—Connie Francis
1956—Jaye P. Morgan	1962—Connie Francis
1957—Doris Day	1963—Connie Francis
1958—Patti Page	1964—Connie Francis
	1965—Barbara Streisand

MOST PROGRAMMED VOCAL GROUP

1953—Four Aces
 1954—Four Aces/Hilltoppers (tie)
 1955—Four Aces/McGuire Sisters
 1956—Four Lads
 1957—Four Lads
 1958—Four Lads
 1959—Four Lads/Four Freshman (tie)
 1960—Kingston Trio
 1961—Kingston Trio/Everly Brothers (tie)
 1962—Kingston Trio
 1963—Four Seasons/Kingston Trio (tie)
 1964—Beatles
 1965—The Beatles

MOST PROGRAMMED ORCHESTRA

1953—Ralph Flanagan
 1954—Ray Anthony
 1955—Ralph Marterie
 1956—Benny Goodman
 1957—Les Brown
 1958—Ray Anthony
 1959—Ray Anthony
 1960—Les Elgart
 1961—Lawrence Welk
 1962—Henry Mancini, Billy Vaughn, Lawrence Welk, Si Zentner (tie)
 1963—Lawrence Welk
 1964—Henry Mancini
 1965—Henry Mancini

MOST PROGRAMMED STUDIO ORCHESTRA

1956—Les Baxter	1960—Percy Faith
1957—Hugo Winterhalter	1961—Billy Vaughn
1958—Billy Vaughn	1962—Billy Vaughn
1959—Ray Conniff	1964—Billy Vaughn

MOST PROGRAMMED SMALL INSTRUMENTAL GROUP

1953—Les Paul & Mary Ford	1956—Bill Haley & His Comets
1954—Les Paul & Mary Ford	1957—George Shearing Quintet
1955—Bill Haley & His Comets	

MOST PROGRAMMED INSTRUMENTALIST

1958—Roger Williams
 1959—Duane Eddy
 1960—Duane Eddy
 1961—Duane Eddy
 1962—Floyd Cramer/Ferrante & Teicher (tie)
 1963—Duane Eddy
 1964—Al Hirt
 1965—Al Hirt

MOST PROMISING MALE VOCALIST

1953—Bob Manning
 1954—Lou Monte
 1955—Sammy Davis, Jr.
 1956—Pat Boone
 1957—Johnny Mathis/Tommy Sands (tie)
 1958—Jimmie Rodgers
 1959—Bobby Darin/Brook Benton (tie)
 1960—Jimmy Jones/Adam Wade (tie)
 1961—Adam Wade
 1962—Jack Jones/George Maharis (tie)
 1963—Jack Jones/Bobby Vinton (tie)
 1964—Jack Jones
 1965—Tom Jones

MOST PROMISING FEMALE VOCALIST

1954—Kitty Kallen	1960—Connie Stevens
1955—Jaye P. Morgan	1961—Linda Scott
1956—Gogi Grant	1962—Joanie Sommers
1957—Betty Johnson	1963—Little Peggy March
1958—Connie Francis	1964—Barbra Streisand
1959—Dodie Stevens	1965—Petula Clark

MOST PROMISING VOCAL GROUP

1954—Four Knights	1960—Brothers Four
1955—Hi-Lo's/DeCastro Sisters (tie)	1961—Limelites
1956—Platters	1962—Lettermen
1957—Hi-Lo's	1963—J's and Jamie
1958—Four Preps	1964—Serendipity Singers
1959—Kingston Trio	1965—The Seekers

MOST PROMISING ORCHESTRA

1954—Les Elgart	1959—Henry Mancini
1955—Richard Maltby	1960—Si Zentner
1956—Dick Jacobs	1961—Bert Kaempfert
1957—Ray Conniff	1962—Si Zentner
1958—Ray Conniff	1963—Joe Harnell
	1965—Sounds Orchestral

MOST PROMISING SMALL INSTRUMENTAL GROUP

1954—Dick Hyman Trio
 1955—Dick Hyman Trio
 1956—Dick Hyman Trio

MOST PROMISING INSTRUMENTALIST

1958—Champs	1962—Mr. Acker Bilk
1959—Dave "Baby" Cortez	1963—Chantays/Bill Pursell (tie)
1960—Bill Black's Combo	1964—Pete Drake
1961—Jorgen Ingmann	1965—Horst Jankowski

EXPLOSION!

ORANGE — EMPIRE RECORDS

Presents



THE PALACE GUARD

Happening!

their single with Don Grady

“Little People” b/w **“Summer Game”**

OE-9164-7

Demanded!

their own exciting first single

“All Night Long” b/w **“Playgirl”**

OE-331

ORANGE — EMPIRE RECORDS

Beverly Hills, California

presenting the hitmakers of today . . . tomorrow's legends

RECORD MANUFACTURERS

- A.D.A.V.**
Box 2691
Detroit, Mich.
- A&M**
8255 Sunset Blvd.
Hollywood, Calif.
- A.P.I.**
2991 Ingledeale Terrace
L.A., Calif.
- ABC-PARAMOUNT**
1501 Broadway, N.Y.C.
- AAR DVARK**
7 West 96th St.
New York 25, N.Y.
- ACADEMY**
157 W. 57th N.Y.C.
- ACAMA**
1608 Argyle
Hollywood, Calif.
- ACAME**
Box 5252
Phoenix, Calif.
- ACCENT**
6533 Hollywood Blvd.
Los Angeles 28, Calif.
- ACCLAIM**
8715 W. 3rd St.
Los Angeles 48, Calif.
- ACE**
804 Vincent Bldg.
Jackson, Miss.
- ACE**
1650 Broadway, N.Y.C.
- ACME**
P.O. Box 366
Manchester, Ky.
- AD**
343—7th Ave.
Oelwein, Iowa
- AD LIB**
157 W. 57th St., N.Y.C.
- ADAIRE**
1036 Red Bird Rd.
Augusta, Ga.
- ADAM**
700 S. Dearborn St.
Chicago 5, Ill.
- ADELL**
P.O. Box 509
Boston, Mass.
- ADMIRAL**
c/o AMY
- ADMIRAL**
Chorlotte, N.C.
- ADVANCE**
545 Arlington Place
Chicago, Ill.
- ADVANCE**
6376 Yucca St.
Hollywood, Cal.
- AETNA**
See Mureo
- AGE**
See USA
- AL-BRITE**
2314—86th St.
Bklyn, N.Y.
- AL MATT**
508 S. Main, Altus, Okla.
- ALA-NICKY**
665 Fifth Ave.
New York, N.Y.
- ALAMO**
16508 S. Main St.
Gardena, Calif.
- ALANNA**
1409 5th Ave.
Pittsburgh, Pa.
- ALCO**
3029 Springboro
Dayton, Ohio
- ALCOR**
See Everest
- ALDEN**
See CIRCA
- ALEGRE**
1045 Southern Boulevard
Bronx, N.Y.
- ALKI**
18882—23rd Ave. So.
Seattle, Wash.
- ALL**
14188 E. Close St.
Whittier, Calif.
- ALLBOY**
See London
- ALEAR**
2433 Valley Ave.
Winchester, Va.
- ALLEY**
213 E. Monroe St.
Jonesboro, Ark.
- ALLSTAR**
1110 Washington St.
S. Houston, Texas
- ALMO INT'L**
See A & M
- ALMONT**
See Canadian-American
- ALON**
See Instant
- ALPHA**
See Don-El
- ALPINE**
P.O. Box 9253
Akron, Ohio
- ALTA**
c/o IND. RECORD
PROD.
19802 N.E. 12th Pl.
N. Miami Beach, Fla.
- ALTONE**
See Continental
- AMAZON**
760½ W. Florence
Los Angeles, Calif.
- AMBER**
165 W. 46 St.
N.Y.C.
- AMCO**
See CIRCA
- AMERICAN**
See Atlantic
- AMERICAN ARTS**
See World Artists
- AMERICAN-INTERNATIONAL**
Hollywood, Calif.
- AMIGO**
1851 Brunner St.
Phila., Pa.
- AMPHORA**
1727 Division St.
Davenport, Iowa
- AMY**
1776 Broadway, N.Y.C.
- ANCHOR**
268 15th Ave.
Newark, N.J.
- ANGEL**
Capitol Tower
Hollywood, Calif.
- ANGELTONE**
See Atlas
- ANTIQUUE**
54 W. Randolph
Chicago, Ill.
- ANTON**
6710-40th Ave. So.
Seattle, Wash.
- ANVIL**
4629 Fenton
Boise, Idaho
- APACHE**
3320 Barham Blvd.
Hollywood, Calif.
- APEX**
951 E. 47th St.
Chicago, Ill.
- APEX**
1023 N. LaBrea Ave.
Los Angeles, Calif.
- APOGEE**
9050 Santa Monica
Los Angeles, Calif.
- APPRO**
509 W. Main
Ashland, Ohio
- APRIL**
See Cameo
- APT**
1501 Broadway, N.Y.C.
- ARAVEL**
4326 Crane St.
L.I.C., N.Y.
- ARC**
9155 Sunset Blvd.
Los Angeles, Calif.
- ARC**
12 Jefferson Ave.
Elizabeth, N.J.
- ARCADE**
2733 Kensington Ave.
Philadelphia, Pa.
- ADMIRAL**
See Amy
- ARDMORE**
4438 N. Greenview Ave.
Chicago, Ill.
- ARGO**
2120 So. Michigan Ave.
Chicago, Ill.
- ARHOOLLE**
Box 5073
Berkeley, Calif.
- ARK**
12418 Claudia Dr.
Houston, Texas
- ARKAY**
1851 Brunner St.
Philadelphia, Pa.
- AROVOX**
243 W. 18 St.
N.Y.C.
- ARISTOPHONE**
1564 Broadway, N.Y.C.
- ARLEN**
12837 Washington Blvd.
Los Angeles, Calif.
- ARLEN**
707 Huntington Pike
Rockledge, Pa.
- ARMOR**
See Nile
- ARRAWAK**
761 Elton Ave.
Bronx, N.Y.
- ART**
P.O. Box 50-66
Miami, Fla.
- ARTEMIS**
9151 Sunset Blvd.
Los Angeles 69, Cal.
- ARTIA**
555 5th Ave., N.Y.C.
- ARTIC**
See Jamie Guyden
- ARTISTE**
1619 Broadway
New York 19, N.Y.
- ARVEE**
7039 Sunset Blvd.
Hollywood, Calif.
- ARWIN**
250 N. Canon Dr.
Beverly Hills, Calif.
- ARZEE**
1739 N. 3 St.
Philadelphia, Pa.
- ASCOT**
See United Artists
- ASK NOT**
6110 Santa Monica Blvd.
Hollywood, Calif.
- ASSOCIATED ARTISTS**
1554 Crossroads of World
Hollywood, Calif.
- ASTRA**
See London
- ASTRO**
205 St. Louis St.
Mobile, Ala.
- ASTRONAUT**
424 S. Pearl St.
Youngstown, Ohio
- AT LAST**
See AFO
- ATCO**
1841 Broadway, N.Y.C.
- ATILA**
P.O. Box 1522
Toledo, Ohio
- ATLANTIC**
1841 Broadway, N.Y.C.
- ATLAS-ANGLETONE**
1697 Broadway, N.Y.C.
- ATHENS OF THE SOUTH**
812-16th Ave. South
Nashville, Tenn.
- ATOM**
Box 113
Oblong, Ill.
- AUDAN**
1717—16th St.
Bakersfield, Calif.
- AUDIO ENGINEERING**
477 Alexander Rd.
Elmhurst, Ill.
- AUDIO FIDELITY**
770—11th Ave., N.Y.C.
- AUDIO SPECTRUM**
Runnemeade, N.J.
- AUDIO SPECTRUM**
c/o Miller Int'l
- AUDITION**
See CIRCA
- AUDITION**
Box 9429
Rochester, N.Y.
- AURA**
See World Pacific
- AURORA**
See Amy-Mala
- AURORA**
25 W. 56 St.
N.Y.C.
- AUTUMN**
70 Dorman Ave.
San Francisco, Calif.
- AVA**
1313 N. Vine
Hollywood
- AVANTI**
Vee-Jay
- AWLER**
165 W. 46 St.
N.Y., N.Y.
- AVENUE**
570 5th Ave., N.Y.C.
- AVON**
15 W. 72nd St.
Suite V-5
New York 23, N.Y.
- B. ATLAS**
2226 McDonald Ave.
Brooklyn, N.Y.
- B & B**
8618 Anacortes St.
Houston, Texas
- B-W**
P.O. Box 337
Wooster, Ohio
- BACK BEAT**
See Duke
- BAGDAD**
1607 El Centre St.
Hollywood 28, Calif.
- BAHAMA**
324 N. E. 35th St.
Miami, Fla.
- BAHAMAS**
Box 174, Nassau,
Bahamas
- BAKERSFIELD**
725 34th St.
Bakersfield, Calif.
- BALL**
1065 E. Vernon Ave.
Los Angeles, Calif.
- BAMBOO**
See Era
- BANDBOX**
5136 W. 41 St.
Denver, Colo.
- BANDERA**
3035 W. 38th St.
Chi., Ill.
- BANDSTAND**
157-36 90th St.
Howard Beach, N.Y.
- BANG**
1650 B'way, N.Y.C.
- BANGAR**
c/o Kay Bank
2541 Nicollet Ave.
Minneapolis, Minn.
- BARBARY COAST**
4430 Santa Monica Blvd.
Los Angeles 29, Calif.
- BARDELL**
See Mercury In N.Y.
- BARONET**
See CIRCA
- BAROQUE**
See Conversaphone
- BARRE**
160 Wood St.
Wilkes-Barre, Pa.
- BARRY**
See Old Town
- BAT**
2203 Maryland Ave.
Baltimore, Md.
- BAYLOR**
850 7th Ave., N.Y.C.
- BAY-TONE**
1509 Fillmore St.
San Francisco, Calif.
- BAY-UKE**
See CIRCA
- BEACH**
Belmont Plaza Hotel
49th St. & Lexington
Ave., N.Y.C.
- BEACON**
518 W. 50 St.
- BEE**
644 Schuykill
Reading, Pa.
- BEE**
c/o IND. RECORD
DIST.
1980 N.E. 12th Pl.
N. Miami Beach, Fla.
- BEE-BEE**
P.O. Box 2741
Washington, D.C.
- BEECHWOOD**
445 Webster Ave.
San Francisco, Calif.
- BECK**
160 2nd Ave. So.
Nashville, Tenn.
- BEL CANTO**
1977 McAllister Ave.
Columbus, Ohio
- BELINDA**
See Jay-Gee
- BELL**
1650 Broadway, N.Y.C.
- BELLA**
See Swan
- BELLAIRE**
P.O. Box 125
Bellair, Tex.
- BELLINA**
1570 Broadway, N.Y.C.
- BELLWOOD**
3012 Botohe Ave.
Richmond, Va.
- BELMONT**
P.O. Box 1763
Hollywood, Calif.
- BELTONE**
1650 Broadway, N.Y.C.
- BENN-X**
See Polar
- BERMA**
c/o Bernice Mason
6223 Selma Ave.
Hollywood, Calif.
- BERTRAM INT'L.**
1224 Koko Head Ave.
Honolulu, Hawaii
- BEST**
P.O. Box 33
Mesilla Park, N.M.
- BETHLEHEM**
1540 Brewster Ave.
Cincinnati, Ohio
- BETTY**
2009 W. 69th St.
Chicago, Ill.
- BIG D**
6511 England Rd.
Houston, Texas
- BIG J**
13938 Vanowen
Van Nuys, Calif.
- BIG L.**
See Cameo
- BIG R**
See Era
- BIG BEN**
6515 Sunset Blvd.
Hollywood, Calif.
- BIG HILL**
See Amy
- BIG COUNTRY**
Box 701
Nashville, Tenn.
- BIG SCOTT**
2232 Race St.
Denver, Colo.
- BIG STYLE**
P.O. Box 322
W. Memphis, Ark.
- BIG TOP**
1619 Broadway, N.Y.C.
(Continued on Pg. 30)

N.Y.C.
St.
Calif.

Hotel
Lexington

Dean Martin

Just completed

sons of katie elder —Paramount

marriage on the rocks —Warner Bros.

Starting

the silencers —Columbia

Latest for  **reprise** 

“Houston”

b/w

“Bummin’ Around”

#0393

In the fall

the dean martin show —NBC-TV

RECORD MANUFACTURERS

(Continued from Pg. 28)

BIG TOP
See Amy

BILLY BOX
619 Windsor Blvd.
Hollywood, Calif.

BINGO
355 Madison Ave.
New Milford, N.J.

BIRD
122 E. Taussig Blvd.
Norfolk, Va.

BIT
1781 Hauser Blvd.
Los Angeles, Calif.

BITOA
See Stereoddities

BLACK GOLD
P.O. Box 8033
Hollywood Station
Memphis, Tenn.

BLANK
P.O. Box 27
Man, W. Va.

BLAST
1721 Broadway, N.Y.C.

BLUE ANGEL
1219 Forest Dr.
Louisville, Ky.

BLUEBIRD
See RCA

BLUE CAT
See Red Bird

BLUE GIANT
3354 Hilton, N.E.
Massillon, Ohio

BLUE HILL
P.O. Box 394
Middletown, N.Y.

BLUE JAY
1821 Orleans Ave.
New Orleans, La.

BLUE MASQUE
See Crusader

BLUE NOTE
43 W. 61st St., N.Y.C.

BLUE ROCK
See Mercury

BLUE STAR
6363 Sunset Blvd.
Hollywood, Calif.

BLUE VELVET
See Brenne

BLUESTOWN
1820 Washington St.
Boston, Mass.

BLUESVILLE
See Prestige

BOARDWALK
114 S. Ocean Ave.
Atlantic City, N.J.

BOBBIE
17th & Sanson
Philadelphia, Pa.

BOBBIN
3903 Olive St.
St. Louis, Mo.

BOBBY
344 4th St.
Trafford, Pa.

BOCART
25 W. 65th, N.Y.C.

BOLERO
See Regand

BOLO
See Vee Jay

BO-MAR
Carlton House
550 Grant St.
Pittsburgh, Pa.

BOMARC
2721 Snyder Ave.
Philadelphia, Pa.

BOMBAY
7905 Cottage Grove
Chicago, Ill.

BON BON
1301 Commonwealth
Boston, Mass.

BONNIE
See Imperial

BONNIE BEE
62 Hillside Ave.
Somerville, N.J.

BOOTLEG
2012 Noble St.
Pitts., Pa.

BORDERLINE
350 W. 40th St., N.Y.C.

BOUNTY
See Electra

BOURBON STREET
2939 Seratine St.
New Orleans 19, La.

BOYD
2609 N. W. 36th St.
Oklahoma City, Okla.

BRAGG
c/o John Capps
728 16th Ave. S
Nashville, Tenn.

BRAND
9109 Sunset Blvd.
Hollywood, Calif.

BRANDES
28 W. 47th St., N.Y.C.

BRASS
7807 Truman
Kansas City, Mo.

BRAVE
1404 Arlington Blvd.
Falls Church, Va.

BRENNE
845 N. 15th St.
Philadelphia, Pa.

BRIAR
See Jubilee

BRIDGES
2600-04 N. Wilmington
Ave., Compton, Calif.

BRITAM
245 5th, N.Y.C.

BRITE-STAR
Newbury, Ohio

BROADWAY
See Sue 245 5th, N.Y.C.

BROKEN
200 W 57 St.
N.Y.C.

BRONCO
See Stacy

BROOKE
Radio Bldg.
Asheboro, N.C.

BROSH
3223 W. Birchwood
Milwaukee, Wisc.

BRUNSWICK
445 Park Ave., N.Y.C.

BUCCANEER
328 O'Ferrell St.
Jackson, Miss.

BUCK
14610 Nimitz St.
Houston, Texas

BUCKINGHAM
See Continental

BUCKLEY
1707 Church St.
Nashville, Tenn.

BUD
1549 N. Vine
Hollywood, Calif.

BUD
41-41 51st St.
Woodside, N.Y.

BUDDY
500 Locust St.
Marshall, Texas

BUENA VISTA
500 S. Buena Vista St.
Burbank, Calif.

BULLS EYE
See CIRCA

BURN
2012 Noble St.
Pitts, Pa.

BURTON
3018 Paukrest Dr.
Los Angeles, Calif.

BUZZ
52-87 79 St.
Elmhurst, N. J.

CBG
1616 Argyle Ave.
Hollywood, Calif.

CGD
See London

C. J.
4803 Indiana Ave.
Chicago 15, Ill.

CAB
120 W. 125th St., N.Y.C.

CADENCE
119 W. 57th St., N.Y.C.

CADETTE
See London

CAEDMON
461 8th Ave., N.Y.C.

CAL-GOLD
See CIRCA

CALDWELL
See Jamie

CALENDER
See Crusader

CALI
P.O. Box 322
Bronxville, N.Y.

CALLA
1650 B'way, N.Y.C.

CALLIOPE
3360 Barham Blvd.
Hollywood 28, Calif.

CAMAY
See Bing

CARMAY
13117 Lackwood Blvd.
Downey, Calif.

CAMDEN
155 E. 24th St., N.Y.C.

CAMELOT
937 South St.
Philadelphia, Pa.

CAMEO
1405 S. Locust St.
Philadelphia, Pa.

CANADIAN AMERICAN
150 W. 55th St., N.Y.C.

CANARY
439 Brewer Dr.
Nashville 11, Tenn.

CANARY
2437 E. 57th St.
Los Angeles, Calif.

CANDEE
See King

CANDID
See Cadence

CANDLELIGHT
410 Main St.,
W. Orange, N.J.

CANDY STRIPE
674 Midwood St., N.Y.C.

CAPA
c/o Medico Music
803-R Gov't. St.
Mobile, Ala.

CAPE
509 N. Kenwood
Glendale, Calif.

CAPITOL
Capitol Tower
Hollywood, Calif.
1739 Broadway, N.Y.C.

CAPRI
See Jay-Gee

CARD
255 W. 55th St.
New York, N.Y.

CARIB
4239 W. Flagler St.
Miami, Fla.

CARIB
Box 174
Nassau, Bahamas

CARICATURE
218 W. 47th St., N.Y.C.

CARLSON
9 Woodmere Road
West Caldwell, N.J.

CARLTON
345 W. 58th St., N.Y.C.

CARMA
1113 Clay St.
Kenner, La.

CARMAY
13117 Lackwood Blvd.
Downey, Calif.

CARMEN
54 W. Randolph St.
Chicago, Ill.

CARNEY
See Jamie

CARNIVAL
350 Chadwick Ave.
Newark, N.J.

CAROUSEL
772 E. McMillan St.
Cincinnati, Ohio

CARRIE
Box 7763
Detroit, Mich.

CASA GRANDE
6 Carter Place
Woburn, Mass.

CASINO
5604 1/2 Hollywood Blvd.
Hollywood, Calif.

CASHMERE
See CIRCA

CATCH
See Era

CATHY
2547-20th Ave.
San Francisco, Calif.

CAVALCADE
23 Broad St.
Bloomfield, N.J.

CAVALIER
387 6th St.
S.F., Calif.

CAWTHRON
See Bing

CEDWICKE
See London

CEE-JAY
893 Morris Ave.
Bronx, N.Y.

CELEBRITY
c/o N.Y. Record Distrib.
15 N. 20th St., N.Y.C.

CELESTE
2845 W. Pico
Los Angeles, Calif.

CELESTIAL
See DeVile

CELTIC
2403 Stewart Ave.
Westbury, N.Y.

CENTAUR
82 Aldine St.
Rochester, N.Y.

CENTURA
1219 N. Beachwood Dr.
Hollywood, Calif.

CENTURY
1429 Hawthorne, St.
Pittsburgh, Pa.

CENTURY, LTD.
See Sable

CEVETONE
130 Newark Ave.
Jersey City, N.J.

CHA CHA
54 W. Randolph St.
Chicago, Ill.

CHALLENGE
1556 No. La Brea
Hollywood 28, Calif.

CHAMBERS
220 E. Anaheim
Long Beach, Calif.

CHAMPION
See Vee Jay

CARD
255 W. 55th St.
New York, N.Y.

CHANDEL
6324 Cassia
Boise, Idaho

CHANNEL
P.O. Box 173
Chicago, Ill.

CHANSON
410 N. 1st
Pulaski, Tenn.

CHANTE
624 S. Michigan Ave.
Chicago, Ill.

CHARGER
See Crusader

CHARLES
729 7th Ave., N.Y.C.

CHARLIE PARKER
See MGM

CHART
P.O. Box 73,
Nashville, Tenn.

CHASE
c/o Chips
808 N. Broad St.
Philadelphia, Pa.

CHAT
1536 3/4 Wilcox
Hollywood 28, Calif.

CHATEAU
1356 Eglinton W.
Toronto, Ont., Canada

CHATTAHOOCHEE
710 N. Maple Dr.
Beverly Hills, Calif.

CHEATHAM
2016 N. Prairie
Dallas, Texas

CHECKER
2120 S. Michigan Ave.
Chicago, Ill.

CHEER
See Blast

CHELSEA
289 3rd Ave., N.Y.C.

CHELSEA
518 So. 2nd St.
Philadelphia, Pa.

CHENE
8831 Sunset Blvd.
Los Angeles, Calif.

CHESS
2120 S. Michigan Ave.
Chicago, Ill.

CHESTNUT
See Jamie /Guyden

CHEVELL
P.O. Box 2081
Ft. Worth, Texas

CHEX
See Jay-Gee

CHICK'S
4013 A Aldine
St. Louis, Mo.

CONGRATULATIONS
TO CASH BOX

"GOTTA
FIND
A WAY"

HAL BURRAGE
M-PAC 7225

"DO
THE 45"

THE SHARPIES
ONE-DERFUL (!) 4835

ONE-DERFUL (!)
RECORDS

1827-29 S. Michigan Ave., Chicago 16, Ill.

TELS: 225-0583

Congratulations!

Thee Midnitters
Tommy Butler
The Boss Tweeds
The Murmaids
Malcolm Hayes



9165 Sunset Blvd. L.A., Calif. 90069
213-CR-55021

Many Thanks to Our many friends Around the World

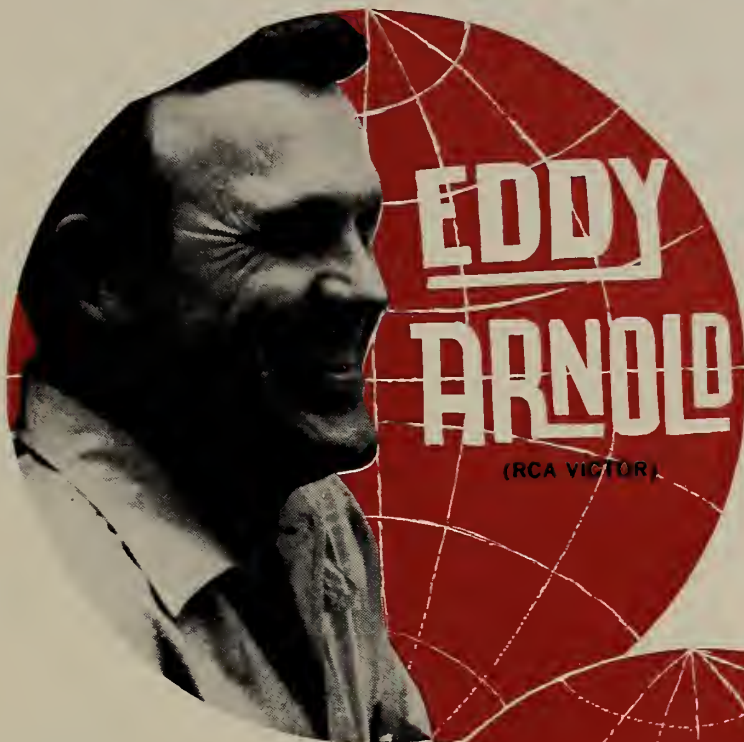

Personal Management:
GERARD W. PURCELL
ASSOCIATES, Ltd.
New York Hollywood

**Thanks
World**

B

R



NIDA

direction:  WILLIAM MORRIS AGENCY, INC.
ESTABLISHED 1898

exclusively: 

publicity: **BRANDY-PAM, Inc. (USA)**
KG Publicity Consultants, Ltd.
(LONDON)

packager "Brenda Lee Show": **ONE NITERS, INC.**

personal management: 
dub allbritten

RECORD MANUFACTURERS

(Continued from Pg. 30)

CHICORY
c/o London

CHIEF
1448 S. Michigan Ave.
Chicago, Ill.

CHOICE
Box 5021
Newark, N.J.

CHORDETTE
See Re-No

CHRIS
209 E. 27th St.
Odessa, Tex.

CHRISTY
15520 El Gato Lane
Los Gatos, Calif.

CHUCKIE
Box 3, Belan, N.M.

CIMA
1591 2nd Ave., N.Y.C.

CIMARRON
P.O. Box 303
Rogers, Ark.

CINEMA
4770 N.W. 7th Ave.
Miami, Tex.

CINEMA
P.O. Box 1224
Mobile, Ala.

CIRCA
1619 N. Cherokee Ave.
Hollywood 28, Calif.

CIRCUS
See Belle Meade

CITATION
See Cuca

CITE
6108 W. Stevenson St.
Milwaukee, Wisc.

CLARE
Box 333
Holcomb, Kan.

CLARK
1554 Crossroads of World
Hollywood, Calif.

CLARK
Box 400, Rt. 1
Goodlettsville, Tenn.

CLASSIC EDITIONS
See Music Minus One

CLAY
P.O. Box 7
Liberty, N.Y.

CLEOPATRA
IND. REC. DIST.
19802 N.E. 12th Pl.
N. Miami Beach, Fla.

CLINTON
109 Clinton St.
New Bedford, Mass.

CLOCK
1650 Broadway, N.Y.C.

CLOUD
200 W. 57 St.
N.Y.C.

CLYMAX
129 E. Fifth
Chester, Pa.

COAST
2534 W. Pico Blvd.
Los Angeles 6, Calif.

COED
1619 Broadway, N.Y.C.

COFFEE HOUSE
See Carlton

COIN
3303 W. Ohio
Midland, Tex.

COLE
823 S. Wabash
Chicago, Ill.

COLISEUM
See London

COLONIAL
710 W. Girard Ave.
Phila, Pa.

COLONIAL
503 W. Franklin St.
Chapel Hill, N.C.

COL PIX
1347 No. Cahvenga Blvd.
Hollywood 28, Calif.

COLT
1615 N. Madison
Chicago, Ill.

COLT 45
See Atco

COLUMBIA
799 Seventh Ave., N.Y.C.

COMBO
6201 Santa Monica Blvd.
Hollywood, Calif.

COMET
See Herald

COMMAND
1501 Broadway, N.Y.C.

COMMERCE
9644 Washburn Rd.
Downey, Calif.

COMPANION
See Coed

CONCEPT
1041 N. Formosa
Hollywood, Calif.

CONCERT CLASSICS
111 W. 57th, N.Y.C.

CONCERTONE
1407 "U" St., N.W.
Washington, D.C.

CONN
1619 Broadway, N.Y.C.

CONQUEST
97 Columbia Heights
Brooklyn, N.Y.

CONSTELLATION
1421 S. Michigan
Chicago, Ill.

CONTACT
1841 Broadway, N.Y.C.

CONTEMPO
See UA

CONTEMPORARY
8481 Melrose Place
Los Angeles 86, Calif.

CONTINENTAL
8730 Sunset Blvd.
Los Angeles 69, Calif.

CONTINENTAL
500 5th Ave. N.Y.C.

CONTINENTAL ARTS
1650 B'way, N.Y.C.

CONVERSAPHONE
132 W. 32nd St, N.Y.C.

COOKIN'
See DC

COOL
617 Exchange Bldg.
Nashville, Tenn.

COPA
See Marquee

CORAL
445 Park Ave., N.Y.C.

CORNUTO
6043 Romaine St.
Hollywood 38, Cal.

CORONA
9341½ Olympic Blvd.
Beverly Hills, Calif.

CORONET
See Premier

CORRECT-TONE
9031 12th St.
Detroit 6, Mich.

CORSICAN
273 Prospect Ave.
Buffalo, N.Y.

CORTLAND
1501 W. Cortland St.
Chicago, Ill.

COSMO
See Simon Says

COTTON
P.O. Box 128
Tucker, Ga.

COUNSEL
1489 Vine St.
Hollywood, Calif.

COUN-TREE
4200 Missouri
E. St. Louis, Mo.

COUNTERPOINT
1674 B'way
N.Y.C.

COUNTRY CAPERS
See London

COUNTRY HIT
See VANDAM

COUNTRY JUBILEE
Demorest, Ga.

COVER
577 Sharon Dr.
Memphis, Tenn.

COWTOWN
P.O. Box 192
Avery, Texas

COX
2510 Rountree
Abilene, Texas

CRACKERJACK
See Sue

CRAIG
See Arnold

CRASH
200 W. 57th
N.Y., N.Y.

CRAZY TOWN
31 Dartmouth
Pueblo, Colo.

CREATIVE
9000 Sunset Blvd.
L.A., Calif.

CREED
19961 Prest St.
Detroit, Mich.

CRESCENDO
3720 27th St.,
Long Island City, N.Y.

CRESCENT
3725 El Cajon Blvd.
San Diego, Calif.

CREST
See CIRCA

CRESTMORE
See Globe

CRICKET
See Pickwick

CRITERIA
See Wes-Mar

CRITERION
6124 Selma Ave.
Hollywood 28, Calif.

CROSBY
1990 Fremont St.
Las Vegas, Nev.

CROSSFIRE
P.O. Box 148
Elsinole, Calif.

CROSSROADS
153-06 N. Hempstead
Tpke., Flushing, N.Y.

CROWN
1435 So. La Crensga
Los Angeles, Calif.

CRUSADE
1619 Broadway, N.Y.C.

CRUSADER
6411 Hollywood Blvd.
Hollywood, Calif.

CRYSTA
24 N. Wabash
Chicago, Ill.

CRYSTAL
340 Wauhegan Rd.
Glenview, Ill.

(Continued on Pg. 36)

Thank You D.J.s...

SHIRLEY ELLIS

and LINCOLN CHASE

THE NITTY GRITTY

THE CLAPPING SONG

THE NAME GAME

I NEVER WILL FORGET

DIRECTION
L. CHASE INC.
LINCOLN CHASE, PRES.



CONGRESS RECORDS, INC.

Current album

**"THE
NAME
GAME"
CGL 3003**

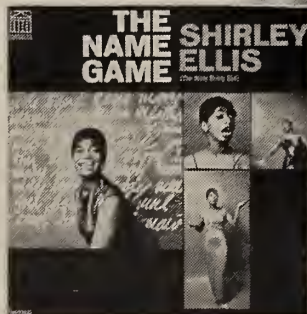

MARY WELLS

SHE SELLS!

SHE SELLS!

SHE SELLS!

SHE SELLS!

SHE SELLS!

SHE SELLS!

SHE SELLS!



CURRENT ALBUM

Mary Wells



20th CENTURY FOX TFM 317

CURRENT SINGLE

"ME WITHOUT YOU"

20th CENTURY FOX 606

EXCLUSIVELY ON



PERSONAL MANAGEMENT

GEORGE SCHECK

161 W. 54th St., New York, N.Y. (212) JU 6-5717

Cash Box DISC JOCKEY POLL 1964/65



WITH THREE FIRSTS
LEADS THE WAY

THE MOST PROGRAMMED SINGLE

1st
DOWNTOWN

THE MOST PROMISING FEMALE VOCALIST

1st
PETULA CLARK

THE MOST PROMISING ORCHESTRA

1st
**SOUNDS
ORCHESTRAL**

HEARTY CONGRATULATIONS TO

**PETULA CLARK
TONY HATCH
AND JOHN SCHROEDER**

PYE RECORDS A.T.V. HOUSE,
GT. CUMBERLAND PLACE, LONDON, W.1.

RECORD MANUFACTURERS

(Continued from Pg. 34)

- CRYSTALETTE**
1600 N. La Brea
Hollywood, Calif.
- CU RAE**
1947 W. Passyunk Ave.
Phila., Pa.
- CUB**
1540 Broadway, N.Y.C.
- CUCA**
123 Water St.
Sauk City, Wisc.
- CULLMAN**
4705 Gallatin
Nashville, Tenn.
- CURIO**
44 Court St.,
B'klyn., N.Y.
- CURRENT**
313 N. Virginia St.
Ontario, Calif.
- CUTIE**
6814 Williamson Ave.
Baltimore, Md.
- CUTT-RITE**
401-5 Jennings
Ft. Worth 4, Texas
- CYCLONE**
See CIRCA
- "D"**
P.O. Box 115
Madison, Tenn.
- D-TOWN**
c/o Music Merchanes,
Inc.
3731 Woodward, Ave.
Detroit 1, Mich.
- DC**
930 F. Street, N.W.
Washington, D.C.
- DCP**
1650 Broadway, N.Y.C.
- DMD**
1441 Broadway
Ann Arbor, Mich.
- D.P.G.**
c/o East Coast Dist.
612 E. Liberty
Norfolk, Va.
- DADE**
See Atlantic
- DA VINCI**
254 5th Ave., N.Y.C.
- DAFFAN**
7408 Schneider
Houston, Texas
- DALA**
P.O. Box 101
Rockville, Conn.
- DANA**
318 W. 48th St., N.Y.C.
- DANCE ALONG**
111 W. 57th St., N.Y.C.
- DANCELAND**
18956 Wyoming
Detroit, Mich.
- DANCO**
1650 Broadway, N.Y.C.
- DANDY**
P.O. Box 2571
Wilmington, Dela.
- DANNY**
1222 Mayo
Irving, Texas
- D'ARCY**
5600 Curlew
Norfolk, Va.
- DARCY**
6515 Sunset Blvd.
Hollywood, Calif.
- DAREM**
49 St. Mark Ave.
Brooklyn, N.Y.
- DAROLINA**
940 W. Sharpe Ave.
Nashville, Tenn.
- DARROW**
See Parktowne
- DASH**
2000 Glenview Ave.
Park Ridge, Ill.
- DAVID**
1650 Broadway, N.Y.C.
- DAVIS**
3301 W. Flourney
Chicago, Ill.
- DAWILLA**
12457 Ventura Blvd.
N. Hollywood, Calif.
- DAWN**
40 Congress Int'l.
550 10th Ave. N.Y.C.
- DAY**
P.O. Box 230
Florence, Miss.
- DAY DELL**
c/o Jamie/Guyden
919 N. Broad St.
Philadelphia, Pa.
- DE-JAC**
Colonial Bldg.
Hewlett, N.Y.
- DE VILLE**
1607 El Centro
Hollywood, Calif.
- DE VOICE**
c/o Penthouse
6119 Pofrero
El Cerrito, Calif.
- DEARBORN**
13200 W. Warren
Dearborn, Mich.
- DEAUVILLE**
1138 N.E. 2nd Ave.
Miami, Fla.
- DEB**
P.O. Box 3185
Lubbock, Texas
- DEBBY**
See Cha Cha
- DEBNA**
See King
- DEBONAIR**
439 E. 119th St.
Los Angeles 61, Calif.
- DECANTER**
See Fargo
- DECCA**
445 Park Ave., N.Y.C.
- DECO**
P.O. Box 655
Hudson, Ohio
- DEE GEE**
1953 Pontious Ave.
L.A., Calif.
- DEE-LEE**
435 C. So. Grove St.
Freeport, N.Y.
- DEL-FI**
6277 Selma Ave.
Hollywood 28, Calif.
- DEL-MAR**
186 Rogers St.
Atlanta, Ga.
- DEL-MAR**
1602 Ave. S
Nashville, Tenn.
- DEL NORTE**
711 Wooland N.W.
Albuquerque, N.M.
- DEL-RAY**
5168 Franklin Ave.
Hollywood, Calif.
- DEL-RAY**
See Blue Hen
- DEL-RIO**
9076 St. Ives Dr.
Los Angeles, Calif.
- DEL-TONE**
6363 Sunset Blvd.
Hollywood, Calif.
- DELAWARE**
116 Gentry Court
Roselle, Ill.
- DELL**
3490 Wade St.
Los Angeles, Calif.
- DELMARK RECORDS**
7 West Grand Avenue
Chicago 10, Ill.
- DELSEY**
See Impala
- DELTA**
236 W. 55th St., N.Y.C.
- DELTA**
90 Sandy Record Sales
Albuquerque, N.M.
- DETAR**
6376 Yucca St.
Hollywood, Calif.
- DELUXE**
1540 Brewster Ave.
Cincinnati, Ohio
- DEMON**
2821 W. View St.
Los Angeles 16, Calif.
- DENNY**
5539 Sunset Blvd.
Hollywood, Calif.
- DERBY**
See Sar
- DERRY**
13380 Capitol Ave.
Detroit, Mich
- DERY**
1311 Needham Ave.,
N.Y.C.
- DESCANT**
Perry, Fla.
- DESIGN**
8-16 43rd Ave.
Long Island City, N.Y.
- DESTINY**
Box 6004
Mobile, Ala.
- DETROIT**
See London
- DETROIT**
677 Newbury
Springfield, Mass.
- DEVILLE**
1607 El Centro
Hollywood, Calif.
- DEUTSCHE-GRAMMOPHON**
See MGM
- DEWEY**
1697 Broadway, N.Y.C.
- DIADON**
5607 Melrose Ave.
Hollywood, Calif.
- DIAL**
See London
- DIAMOND**
1650 Broadway, N.Y.C.
- DICE**
1325 Lincoln Ave.
Cincinnati, Ohio
- DIMENSION**
See Colpix
- DIRECTIONAL SOUND**
See Premier
- DISNEYLAND**
500 S. Buena Vista St.
Burbank, Calif.
- DISTINGUISHED**
See Scepter
- DITTO**
1820 Washington St.
Boston, Mass.
- DIXIE**
c/o Alanna Dist.
1409 5th Ave.
Pittsburgh Pa.
- DIXIELAND JUBILEE**
8566 Sunset Blvd.
Los Angeles 46, Calif.
- DO-RA-ME**
115 1/2 3rd Ave., No.
Nashville 3, Tenn.
- DOBBIE**
See Downey
- DOCK-MACK**
2537 Adams Ave.
San Diego, Calif.
- DOCUMENTARIES,
UNLIMITED**
1201 34th Ave., L.I.C.,
N.Y.
- DODGE**
See Myrl
- DOLPHIN**
575 Madison Ave., N.Y.C.
- DOLTON**
See Liberty
- DOMAIN**
1313 North Ave.
Hollywood 28, Calif.
- DOMAIN**
1489 Vine St.
Hollywood, Calif.
- DOMAIN**
c/o London
539 W. 25 St.
N.Y.C.

(Continued on Pg. 35)



Thanks

Our cup overflows with gratitude.

To our many friends who are helping us make "AROUND THE CORNER", "TAKE ME BACK", "YOU BETTER GO", "IT'S GONNA TAKE A MIRACLE", "DON'T LET ME DOWN" and "THINK OF YOU" chartmakers!

To the wonderful nightpeople at *Columbia Records*, *DCP*, *Roulette*, *MGM*, *Mercury* and *Atco*, our sincerest thanks; and those of *The Duprees*, *Little Anthony & The Imperials*, *Derek Martin*, *The Royalettes*, *Lynn Long* and *April Stevens & Nino Tempo*.

Don Costa Teddy Randazzo Stan Cation

South Mountain Music Publishing Company, Inc.
237 West 54th Street, New York City, PLaza 7-7630

RECORD MANUFACTURERS

(Continued from Pg. 36)

DOMAR
449 W. Lewis
Scottsdale, Ariz.

DON AND MIRA
South Bend, Ind.

DON-EL
2020 Ridge Ave.
Philadelphia, Pa.

DONNA
6277 Selma Ave.
Hollywood, Calif.

DOOTO
9512 S. Central Ave.
Los Angeles, Calif.

DORE
1481 No. Vine St.
Hollywood, Calif.

DORIAN
1815 N. Kenmore Ave.
Hollywood 27, Calif.

DOT
1507 No. Vine St.
Los Angeles, Calif.

DOTTIE
2534 W. Pico Blvd.
Los Angeles 6, Calif.

DOUBLE H
Box 10007
Greenville, S.C.

DOUBLE L
See Liberty

DOUBLE CHECK
2104 Lake Ave.
Baltimore, Maryland

DOUBLE DEE
3029 Oregon St.
Paducah, Ky.

DOUBLET
111 W. Washington St.
Chicago, Ill.

DOWNBEAT
See Golden Artists

DOWN HOME
1221 Harwood Dr.
Nashville, Tenn.

DOWNEY
13117 Lakewood Blvd.
Downey, Calif.

DRA
8961 Sunset Blvd.
Hollywood, Calif.

DRANDELL
2106-5th Ave.
Los Angeles, Calif.

DREW-BLAN
P.O. Box 444
Morgan City, La.

DRIFTWOOD
P.O. Box 26
Palmer, Mich.

DRUM BOY
2452 S. Kedzie Ave.
Chicago 23, Ill.

DRUMMOND
13380 Capitol Ave.
Oak Park, Mich.

DUB
P.O. Box 275
Nashville, Tenn.

DUCHESS
c/o Epitome
Chicago 20, Ill.

DUEL
157 W. 57th St., N.Y.C.

DUEL-TONE
1840 South Elena
Redondo Beach, Calif.

DUKE
2809 Erastus St.
Houston 26, Tex.

DUMAS
804 E. Imperial
Los Angeles 59, Calif.

DUNES
See Big Top

DUNHILL
321 S. Beverly Dr.
Beverly Hills, Cal.

DUO
See Stereoddities

DUO-DISC
8831 Sunset Blvd.
Los Angeles, Calif.

DYER-BENNETT
P.O. Box 235
Woodside 77, N.Y.

DYMO
577 14 St.
Oakland, Calif.

DYNAMITE
c/o Circa

DYNASTY
1637 Vista Del Mar
Hollywood 28, Calif.

DYNOVOICE
See Amy

EL-JAY
22 W. 56th St., N.Y.C.

EM
2863 N. 16th St.
Phoenix, Ariz.

EPI
1477 Main St.
Bridgeport, Conn.

EAGLE
Kermit, Texas

EAST COAST
410 W. 115th St., N.Y.C.

EAST END
3329 W. 6th St.
Fort Worth, Texas

EASTERN
See Sue

EBB TIDE
See CELTIC

EBONY
1417 S. 13th St.
Abilene, Texas

ECHO
P.O. Box 2512
Sepulveda, Calif.

ECO
See Acclaim

ECCO
490½ University
Pocatello, Idaho

EDEN
See Era

EDGE
Brooklyn, N.Y.

EDGEWOOD
150 W. 55th St., N.Y.C.

EKCO
832 Leona Ave.
Columbus, Ohio

EDIT
See London

EKO
c/o TRUE-EKO
6004 7th Ave.,
Brooklyn, N.Y.

EL-JAY
Box 406
Cleveland, Miss.

ELECT
6223 Selma Ave.
Hollywood 28, Calif.

ELECTRO
4151½ E. 6th St.
Hattiesburg, Miss.

ELEKTRA
51 W. 51st St., N.Y.C.

ELVITRUE
306 S. 16th St.
Wilmington, N.C.

EMANUEL
11009 S. Main St.
Los Angeles, Calif.

EMBER
150 W. 55th St., N.Y.C.

EMERSON
See Musicnote

EMIT
See Diamond

EMKAY
1650 Broadway, N.Y.C.

EMMY
See Original Sound

EMPALA
See DeVille

EMPEROR
310 Wilbert St.
Wheeling, W. Va.

EMPIRE
323 Cedar St., S.W.
Washington, D.C.

EMPIRE
90 World-Wide
1650 Broadway, N.Y.C.

EMPIRE
477 Park Ave.
E. Hartford, Conn.

EMPRESS
See Valmor

END
See Roulette

ENITH INT'L
1549 N. Vine St.
Hollywood 28, Calif.

ENJOY
271 W. 125th St., N.Y.C.

ENSIGN
See Smash

ENTERPRISE
c/o Arc Dist.
13415 Lyndon
Detroit, Mich.

ENTERPRISE
1348 Larimer
Denver, Colo.

ENTREE
3155 Industrial Road
Las Vegas, Nevada

EPIC
799 7th Ave., N.Y.C.

ERA
6515 Sunset Blvd.
Hollywood, Calif.

ERMINE
See CORTLAND

ESP-DISK
180 Riverside
New York, N. Y.

ESQUIR
11410½ Hempstead Hwy.
Houston, Texas

ESSAR
P.O. Box 38444
Hollywood, Calif.

ETC.
1697 Broadway, N.Y.C.

ETIQUETTE
P. O. Box 582
Tacoma 1, Wash.

EUREKA
1471 N. Tamarind Ave.
Hollywood 28, Calif.

EUROTONE
47 E. 44th St.
N.Y.C.

EVA
Box 2921
Hollywood 28, Calif.

EVENT
10 Hardy Rd.
Westbrooke, Me.

EVEREST
1313 N. Vine
Hollywood

EVERLAST
See Enjoy

EXCELLO
See Naashboro

EXCLUSIVE
617 Exchange Bldg.
Nashville, Tenn.

EXECUTIVE
19 S. LaSalle St.
Chicago, Ill.

(Continued on Pg. 40)

SALUDOS to CASH BOX

On Your 23rd Anniversary

from

HERB ALPERT & THE
TIJUANA BRASS
BAJA MARIMBA BAND
WE FIVE



BILL DANA
CHRIS MONTEZ
LUCILLE STARR
CANADIAN SWEETHEARTS

8255 Sunset Blvd. ☞ Los Angeles, California



RECORD PEOPLE SAY WE'RE THE WORLD'S CAPITOL.

If the record you're looking for was made in Hong Kong instead of Hollywood, or Beirut instead of New York, come to us.

We import records from all over.

Time was, you had to go directly to the source to get the record you wanted. That involved a lot of paper work, translations, customs, foreign exchange, and all that. Then, we went to work and simplified things.

Now you just come to Capitol Records International, and you get the labels you want, extra-fast, direct from New York.

(Choose from the vast catalogs of Electrola, English-Columbia, H.M.V., La Voce del Padrone, La Voix de Son Maître, Odéon and Pathé.)

So, cash in on fast-moving import sales the easy way. Contact your man at the Capitol — the Capitol Records International Corp., 1290 Avenue of the Americas, New York City 10019.



RECORD MANUFACTURERS

(Continued from page 38)

EXETER
9309 Album Ave.
El Paso, Texas

EXODUS
See CIRCA

E-X-P-A-N-D-E-D
13117 Lakewood Blvd.
Downey, Calif.

EXPO
See Palette

EXPRESS
711 Crescent
Memphis, Tenn.

F.F.V.
P.O. Box 2630
Phila., Pa.

FGF
9416 Highland Pl.
Arvada, Colo.

FABBRI
5533 Hollywood Blvd.
Hollywood, Calif.

LABOR
3609 W. Olive
Burbank, Calif.

FACTION
1680 N. Vine
Hollywood, Calif.

FAIRLANE
See King

FAIRMOUNT
See Cameo Paveway

FAIRWAY INT'L
2221 W. Olive
Burbank, Calif.

FAITH & FREEDOM
5901 Rose Ave.
Long Beach, Calif.

FALCON
21129 S. Michigan Ave.
Chicago 16, Ill.

FALEN
1270 6th Ave., N.Y.C.

FALEW
1270 Sixth Ave.
N.Y.C.

FAME
See Vee Jay

FAMOUS
8 Harwick Rd.
Westbury, N. Y.

FANNIN
P.O. Box 38
Blue Ridge, Ga.

FANTASY
855 Treat Ave.
San Francisco 3, Calif.

FARGO
P.O. Box 656
Lynbrook, L.I., N.Y.

FARO
5004 Melrose Ave.
Hollywood, Calif.

FAYETTE
See Swan

FAVOR
See Cameo

FEATURE
See Monarch

FEDERAL
1540 Brewster Ave.
Cincinnati, Ohio

FELICE
1697 Broadway, N.Y.C.

FELSTED
See London

FERNWOOD
297 N. Main St.
Memphis, Tenn.

FESTIVAL
See King

FIDELITY
8508 Sunset Blvd.
Hollywood 46, Calif.

FIASCO
See Audio Engineering

FIESTA
1619 Broadway, N.Y.C.

FIFO
P.O. Box 47
Hollywood, Calif.

54
306 W. 54th St.
Los Angeles, Calif.

FILM
6087 Sunset Blvd.
Hollywood, Calif.

FINCH
3250 Harvey Ave.
Cincinnati, Ohio

FINE
4630 Kosarek
Corpus Christi, Texas

FINER ARTS
60 So. Glen Coast
Denver 22, Colo.

FINK
110 Pine Ave.
Long Beach, Calif.

FIRE BALL
188 Lisbon St.
Lewiston, Maine

FIREBIRD
See Cameo

FIRMA
561 W. 16th St.
Chicago, Ill.

521
1134 Fulton St.
Brooklyn, N.Y.

FLAG
P.O. Box 827
Lucedale, Miss.

FLAME
1325 Franklin Ave.
New Orleans, La.

FLAMINGO
105-21 66th Ave.
Forest Hills, N.Y.

FLASH
Box 68
Senatobia, Miss.

FLASHBACK
See Amy

FLAT-GIT-IT
11703 E. Everest St.
Norfolk, Calif.

FLICK
18424 Gallagher
Detroit 34, Mich.

FLIGHT
c/o Masters, Inc.
6290 Sunset Blvd.
Hollywood, Calif.

FLING
See Fire

FLIP
618 S. Ridgeley Dr.
Los Angeles, Calif.

FLO-JO
P.O. Box 208
Luray, Va.

FLORIDA
453 W. 27th
Hialeah, Fla.

FOCUS
See Atlantic

FOLKSING
See London

FOLKWAYS
165 W. 46th St., N.Y.C.

FONTANA
See Mercury

FORD
125 E. 50 St.
N.Y.C.

FOREST GREEN
1225 6th Ave.
N.Y.C.

FORTUNE
3942 Third Ave.
Detroit 6, Mich.

FORUM
See Roulette

FOUNTAIN
P. O. Box 1032
Columbus, Ga.

FOUR J
3507 S. Bronson Ave.
Los Angeles Calif.

FOUR V
See Trans-Atlas

4 CORNERS
See Kapp

FOURMOST
7118 Coldwater Canyon
N. Hollywood, Calif.

FOUR STAR
305 S. Fair Oaks Ave.
Pasadena, Calif.

49th STATE HAWAII
1023 N. La Brea Ave.

FRANC
5433 North 22nd Rd.
Arlington 5, Va.

FRANDY
See Atlantic

FRANK
Cooperstown, N.Y.

FRANK BUCK
Cooperstone, N.Y.

FRATERNITY
413 Race St.
Cincinnati, Ohio

FREEDOM
6920 Sunset Blvd.
Hollywood, Calif.

FRESH
See CIRCA

FRIENDLY
Cornelia, Ga.

FRIENDLY FIVE
1250 S. Albany
Chicago, Ill.

FRISCO
1140 N. Claiborne Ave.
New Orleans 16, La.

FROLIC
4965 Bruce Dr.
Beaumont, Texas

FUSIMO
347 W. Lusher Ave.
Elkhart, Ind.

FULTON
723 E. 81 St.
Brooklyn, N. Y.

FUTURE
1086 East College Ave.
Batesville, Ark.

G-CLEF
19 Arlington St.
Boston, Mass.

GMA
230 N. Michigan Ave.
Chicago, Ill.

GNP
8566 Sunset Blvd.
Hollywood 28, Calif.

G. S. P.
1635 N. Hudson
Hollywood 28, Calif.

GABLE
P.O. Box 10163
Knoxville, Tenn.

GAIT
443 Clinton Ave.
B'klyn, N.Y.

GALAHAD
11703 E. Everest St.
Norwalk, Calif.

GALAXY
See Fantasy

GALENA
11922 E. 7th St.
Tulsa, Okla.

GALLIO
P.O. Box 535
Santa Paula, Calif.

GALLANTRY
1676 W. Swan
Tucson, Arizona

GAME TIME
1650 B'way, N.Y.C.

GAMBIT
See CIRCA

GAR-LO
397 Passaic Ave.
Lodi, N.J.

GARDENA
145 W. 154th St.
Gardena, Calif.

GARLIN
11034 Blix St.
N. Hollywood, Calif.

GARPAX
Box 669
Hollywood, Calif.

GASP
1916 Fairbanks Rd.
Baltimore, Md.

GASS
6201 Santa Monica Blvd.
Hollywood, Calif.

GATEWAY
234 Forbes Ave.
Pittsburgh, Pa.

GAYE
P.O. Box 13612
Atlanta, Ga.

GAYLORD
See Monument

GAYNOTE
See Coast

GEE-BEE
Box 174, Albany, Ga.

GEE
See Roulette

GENERAL AMERICAN
See World Artists

GEND
See Vee-Jay

GENIE
P.O. Box 93
Deer Park, L.I., N.Y.

GEORGE
See London

GENEVA
65 E. 55th St.
N.Y.C.

GIBRALTAR
60 Main St.
E. Orange, N.J.

GILLETTE
5539 Sunset
Hollywood, Calif.

GINA
1320 S. Howard
Philadelphia, Pa.

GLAD
560 5th Ave., N.Y.C.

GLAD-HAMP
165 W. 46th St., N.Y.C.

GLENN
Box 82
Palmdale, Calif.

GLENN
P.O. Box 841
Hammond, Ind.

GLOBAL
725 34th St.,
Bakersfield, Calif.

GLOBE
420 Board St.
Nashville 3, Tenn.

GLODUS
1650 Broadway, N.Y.C.

GLORY
157 W. 57th St., N.Y.C.

GLOVER
1697 Broadway, N.Y.C.

GOLD
See Amy

GOLD ARROW
See CIRCA

GOLDBAND
P.O. Box 254
Lake Charles, La.

GOLD STANDARD
Box 35
Nashville, Tenn.

GOLDWAX
See Vee Jay

GOLDEN
See A.A.

GOLDEN ARTISTS
P.O. Box 5081
302 E. Purdue
Lubbock, Texas

GOLDEN CREST
220 Broadway
Huntington Station, N.Y.

GOLDEN EAGLE
See Jamie/Guyden

GOLDEN LEAF
1663 Eddington Rd.
Cleveland Heights, Ohio

GOLDEN RING
See Soma

GOLDEN STATE
665 Harrison
San Francisco, Calif.

GOLDEN WORLD
4039 Buena Vista
Detroit, Mich.

GONE
See Roulette

GOODLUCK
4215 Gunderson
Berwyn, Ill.

GOOD TIME JAZZ
8481 Melrose Place
Los Angeles 46, Calif.

GOOFUS
402 Wooster Rd.
Mt. Vernon, Ohio

GORDY
See Tamla

GOSPEL
See Savoy

GOSPEL JUBILEE
c/o Ralph's Radio Music
Demarest, Ga.

GOTHAM
1401 S. 10th St.
Philadelphia 46, Pa.

GRAHAM
See Circa

GRAND AWARD
1501 Broadway, N.Y.C.

GREAT LAKES
138 Duffield
Detroit, Mich.

GREGMARK
1610 N. Argyle
Hollywood, Calif.

GREGORY
See Terry
(Continued on Pg. 42)



May you continue to prosper . . .

ERNIE FREEMAN

"A WORLD OF THANKS" STAN GETZ

GETZ AU GO GO



THE NEW STAN GETZ QUARTET FEATURING ASTRUD GILBERTO



GETZ AU GO GO V/V6-8600

GETZ/GILBERTO

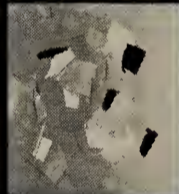

GETZ/GILBERTO V/V6-8545
Winner of Three Grammy's

JAZZ SAMBA STAN GETZ CHARLIE BYRD

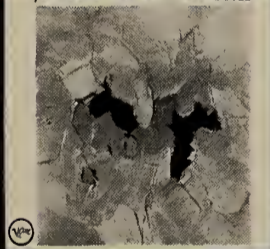

JAZZ SAMBA V/V6-8432



focus
stan
getz
composed and
arranged by
eddie
sauter
concertmaster
henry hay

FOCUS V/V6-8412



Verve Records is a division of Metro-Goldwyn-Mayer, Inc.



6 HIT RECORDS

3 ON TOWER

IAN WHITCOMB
NERVOUS #155

THE SUNRAYS
I LIVE FOR THE SUN #148

JOE LEAHY
LIFE #150



3 ON UPTOWN

ODESSA HARRIS
THE COLOR OF HIS LOVE IS BLUE #711

MARCIA GEE
BABY I NEED YOU #704

TOMMY MOSLEY
YOU LIED, I CRIED, LOVE DIED #706

RECORD MANUFACTURERS

(Continued from pg. 42)

KELTONE INT'L
14213 Oxnard St.
Van Nuys, Calif.

KEM
1107 N. El Centro
Hollywood, Calif.

KENO
See CIRCA

KENOVA
801-17th Ave., So.
Nashville 4, Tenn.

KENT
1435 So. La Cienega Ave.
Los Angeles, Calif.

KEYNOTE
See Tag

KHOURY'S
Railroad & Bilbao Sts.
Lake Charles, La.

KIMBERLY
5810 S. Normandie
Los Angeles, Calif.

KIMCO
9006 Sunset Blvd.
Hollywood, Calif.

KIMLEY
See Circa

KING
1540 Brewster Ave.
Cincinnati 7, Ohio

KINGSTON
415 Schuykill Ave.
Reading, Pa.

KIP
45 W. 39th St., N.Y.C.

KISKI
Box 116
North Apolla, Pa.

KISS-KISS
261 Cumberland St.
Brooklyn, N.Y.

KITE
2520 Amarillo St.
Baton Rouge, La.

KLIME
See KM

KLUB
4 Column St.
Greenville, S.C.

KNIGHT
6425 Hollywood Blvd.
Hollywood, Calif.

KNOCKOUT
Sunset-Vine Tower
Hollywood, Calif.

KO
See Scepter

KOOL
See All Star

L-G
4200 Missouri Ave.
E. St. Louis, Ill.

LLP
345 W. 58th N. Y. C.

LMI
408 W. 57th St., N.Y.C.

LA BELLE
1617 El Centro
Hollywood, Calif.

LA LOUISIANNE
2823 Johnston St.
Lafayette, La.

LAGUNA
2400 S. Western
Los Angeles, Calif.

LANDA
See Jamie

LANOR
P.O. Box 633
Church Pt., Pa.

LANROD
Box 935
Irving, Texas

LAP INT'L
Sunset Vine Tower
Hollywood 28, Cal.

LAREDO
See Bandera

LARGO
See CIRCA

LARK
122 E. Alexandra Blvd.
Gardena, Calif.

LARRY
See Trace

LASH
1326 Kerper St.
Philadelphia 11, Pa.

LAITNI
965 S. Magnolia
Los Angeles 6, Calif.

LAUREN
See Michele

LAUREN
5920 Smiley Dr.
Culver City, Calif.

LAVENDER
See Indigo

LAVENDER
32nd & Jasper Rd.
Springfield, Ore.

LAVETTE
1650 Broadway, N.Y.C.

LAWN
See Swan

LE CAM
P.O. Box 1152
Ft. Worth, Texas

LE MONDE
See Le Grand

LEADER
136 E. 57th St., N.Y.C.

LECTERN
See Eureka

LECTRON
See Rite

LEE
P.O. Box 434
Galveston, Texas

LEGATO
See Sue

LEGEND
153 W. 51st St., N.Y.C.

LEGRAND
817 Church St.
Norfolk, Va.

L'ELGANT
113 W. 47th St., N.Y.C.

LEMAY
c/o Dart Sales

LENOX
See Ad Lib

LEO
See Gateway

LESSIE
P. O. Box 207
San Antonio, Texas

LEVEE
5652 Daniels Ave.
Dallas, Tex.

LEWCO
881 10th Ave.
New York, N.Y.

LIBAN
5606 Greer Ave.
Los Angeles, Calif.

LIBERTY
6920 Sunset Blvd.
Hollywood, Calif.

LIBERTY BELL
See Constellation

LIKEYOUNG
4610 Kester Ave.
Sherman Oaks, Cal.

LIMELIGHT
See Mercury

LIN
204 E. California St.
Gainesville, Tex.

LINDA
See Faro

LINDA
P.O. Box 423
Jacksonville, N.C.

LINDY
223 Main St.
Lacrosse, Wisc.

LINJO
427 W. San Antonio
El Paso, Texas

LINK
See GNP

LION
See MGM

LITTLE NASHVILLE
45 Allen Dr.
Charleston Heights, S.C.

LITTLE SHIRLEY
See Mayhams

LITTLE STAR
1600 N. La Brea
Hollywood 28, Calif.

LITTLE TOWN
Box 851
Fall River, Mass.

LIVING LEGEND
6000 Sunset Blvd.
Hollywood 28, Calif.

LIZA
1700 Broadway, N.Y.C.

LLOYDS
142 W. 49th St.
N.Y.C.

LLUVIA
See Myrl

LOADSTONE
163 Orizaba Ave.
San Francisco, Calif.

LODE
9109 Sunset Blvd.
Los Angeles, Calif.

LODESTAR
11225 Ewing Circle
Minneapolis, Minn.

LOMA
4000 Olive Ave.
Burbank, Calif.

LONDON
539 W. 25th St., N.Y.C.

LOLA
See Atlantic

LONGHORN
2631 Fonville Dr.
Dallas, Tex.

LOOP
See D.C.

LORRAINE
411 Gordon St.
Reading, Pa.

LOUIS
See London

LU-PINE
See Atlantic

LUCKY
P.O. Box 631
Cincinnati, Ohio

LUCKY FOUR
5304 W. 25th St.
Chicago, Ill.

LUCKY TOKEN
Box 38053
Hollywood, Calif.

LUDIX
See Capitol

LUMMTONE
P.O. Box 11121
Los Angeles, Calif.

LUTE
7250 Beverly Blvd.
Hollywood, Calif.

LUXOR
38 Marlene Dr.
Syosett, N.Y.

LYNNE
549 N. Vine
Hollywood, Calif.

LYRIC
See Khoury

LYRIC
1747 N. 33rd St.
Philadelphia, Pa.

M-PAC
See One-der-ful

M.C.A.
1522 Baronne St.
New Orleans, La.

MCR
10637 S. Vermont
Los Angeles, Calif.

MGM
1540 Broadway, N.Y.C.

M-H
2553 Imperial Ave.
San Diego, Calif.

M & M
1215 E. 53rd St.
Chicago, Ill.

MMC
P.O. Box 111
Ralston, Nebraska

MMO
710 10th Ave., N.Y.C.

MOC
See London

MVR
21 New Hyde Park Rd.
Franklin Sq., N.Y.

MACK IV
California Rec. Dist.
3009 W. Pico Blvd.
Los Angeles, Calif.

MAGIC VIOLINS
See Synthetic Plastics

MAGNA
337 1/2 Valley Dr. N.
Beckley, W. Va.

MAGNASOUND
See Monument

MAGNET
1616 N. Argyle
Los Angeles, Calif.

MAGNUM
Hollywood, Calif.

MAHALO
McCully Square
1888-H Kalakaua Ave.
Honolulu, Hawaii

MAINSTREAM
1290 6th Ave., N.Y.C.
See Amy

MALA
See Amy

MALIBU
Commercial Trust
15th & Market
Philadelphia, Pa.

MAMA
3814 E. 147th St.
Cleveland, Ohio

MANCO
P.O. Box 10188
Ft. Worth, Tex.

MAR-BEN
Sid Williams One-Stop
1606 N. Broad St.,
Phila.

MAR-MAR
c/o Chess

MAR-VEL
See Glenn

MAR-V-LUS
c/o One-Der-Ful
1829 S. Michigan Ave.
Chicago, Ill.

MARBILL
c/o A&L
1819 Fairmount Ave.
Philadelphia, Pa.

MARC
See Tri-Disc

MARK III
449 Clinton Ave.
Newark, N.J.

MARK IV
2120 Connally Dr.
East Point, Ga.

MARKIE
See U.S.A.

MARLENE
See Myers

MARLIN
See Cover

MARLO
See Stag

MARLU
See Scepter

MARQUEE
4609 Delano
Houston 4, Texas

MARTIAN
Box 38530
Hollywood, Calif.

MAR-TONE
Box 247
Harrodsburg, Ky.

MAST
See CIRCA

MASTER
See Roulette

MASTERS, INC.
6290 Sunset Blvd.
Hollywood, Calif.

MASTERSEAL
See Continental

MASTERSOUND
See Laitini

MASSACHUSETTS
1820 Washington, St.
Boston, Mass.

MAVERICK
12065 Beacon
Seattle, Wash.

MAXX
See Amy

MAY
See Colpix

MAYHAMS
12 West 117 St.
N.Y.C.

MCKINNON
See Lorraine

MECCA
970 3rd Ave.
Seattle, Wash.

MEDALLION
See Kapp

MEDLEY
See Moonglow

MEGA SOUND
25 Heid Ave.
Dayton, Ohio

MEL-O-DY
See Tamla

MIRI
23 Sperling Dr.
Amella, Ohio

MENORAH
257 E. Broadway, N.Y.

MERCURY
35 E. Wacker Dr.
Chicago, Ill.

MERMAID
See Sinclair

MERRI
2437 E. 57th St.
Los Angeles, Calif.

MERRY-GO-ROUND
1650 Broadway, N.Y.C.

MESA
7101 University Ave.
La Mesa, Calif.

METEOR
1794 Chelsea Ave.
Memphis, Tenn.

METRO
See MGM

METRONOME
117 West 48th St.
N.Y.C.

MICHELLE
220 E. 26th St.
N.Y.C.

MICHELLE
2705 Bainbridge Ave.
N.Y.C.

MID-SOUTH
See Fernwood

MIDNIGHT
See Aravel

MIDWAY
1606 Argyle
Hollywood, Calif.

We are interested in
all kinds of masters
for our \$1.98
STATUS Label
The big new budget
subsidiary of



**PRESTIGE
RECORDS, INC.**

203 South Washington Ave.
Bergenfield, N.J.
(201) 384-6900

The Leading Jazz-Folk Company
In America For The Past 15 Years

DON'T ORDER
THIS SINGLE NOW . . .
WAIT TILL IT'S
TOP TEN WITH A
RED BULLET

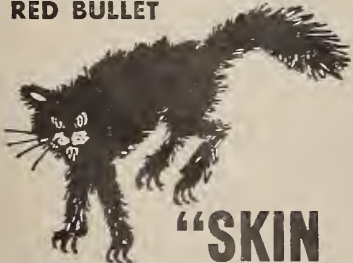

"SKIN
THE CAT"

by #5002
Jimmy Merchant

BO-MAR RECORDS
550 Grant St., Pittsburgh, Pa.

INTERNATIONAL SONG
CHANTEUSE

ELVALINA

"PARAGUAS"

B/W

"CALL ME"



GAYTAN RECORDS

MARTINIQUE HOTEL
NEW YORK CITY
DISTRIBUTED BY
OLYMPIA DISTRIBUTORS



***wow, it's been a
wonderful year!—Thanks***

JOHNNY TILLOTSON

Recording exclusively for:

TANRIDGE PRODUCTIONS

exec. producer — PAUL TANNEN

Released internationally:



Personal Management:

Scandore
Hollywood



Shayne Inc.
New York



Direction:



RECORD MANUFACTURERS

(Continued from Pg. 44)

MIKE
1650 B'way, N.Y.C.

MILESTONE
See CIRCA

MILLER INTERNATIONAL
901 E. Clements Br. Rd.
Cunneville, N.J.

MILO
403 N. 4th St.
Harrison, N.J.

MINARET
1808 West End Bldg.
Nashville, Tenn.

MINIT
P.O. Box 650
New Orleans, La.

MINT
132 Nassau St., N.Y.C.

MIRROR
See Globe

MIST
See CIRCA

MISTER MAESTRO
7 Central Park West
N.Y.C.

MR. PEEKE
See Vee-Jay

MIZON
See Dock-Mack

MOBILE FIDELITY
Box 336
Burbank, Calif.

MODE
8295 Sunset
Culver City, Calif.

MODERN
9817 W. Wash. Blvd.
Culver City, Calif.

MOHAWK
145 W. 47th, N.Y.C.

MONARCH
4852 W. Jefferson
Los Angeles, Calif.

MONEY
2578-80 W. Rio Blvd.
Los Angeles, Calif.

MONEYTOWN
See Variety

MONITOR
413 W. 50th St., N.Y.C.

MONITOR
1916 Fairbanks Rd.,
Balto, Md.

MONOGRAM
See Era

MONOMY
P.O. Box 719
Granville, Ohio

MONSTER
105 W. 55th St., N.Y.C.

MONTEL
See Jamie

**MONTICANO RECORDS
& ENTERPRISES**
2955 Fendall St.
Montreal 26, Quebec

MONUMENT
530 W. Main St.
Hendersonville, Tenn.

MONUMENTAL
See Bat

MOODSVILLE
See Prestige

MOONGLOW
6539 Selma
Hollywood, Calif.

MOSAIC
See Era

MOTHER LODE
550 Fifth Ave., N.Y.C.

MOTOWN
2648 W. Grand Blvd.
Detroit 8, Mich.

MOVIN'
P.O. Box 73282
Los Angeles 8, Calif.

MUNDO
See Kama

MURCO
220 Belmont Bldg.
Shreveport, La.

MUSART
16508 S. Main St.
Gardena, Calif.

MUSE
See Herald

MUSIC CITY
1815 Alcatraz
Berkeley, Calif.

MUSIC MAKERS
6 W. 57th St., N.Y.C.

MUSIC NOTE
250 W. 57th, N.Y.C.

MUSIC PIT
4 Broad St. S.W.
Atlanta, Ga.

MUSICTONE
445 W. 50th St.
New York, N. Y.

MUSIC VOICE
826 7th Ave, N.Y.C.

MUSIC WORLD
1650 B'way
N.Y.C.

MUSICOR
826 7th Ave, N.Y.C.

MUSTANG
3332 N. Glenn Dr.
Phoenix, Ariz.

MUTUAL
1314-24 S. Howard
Philadelphia, Pa.

MYERS
208 N. Broad St.
Philadelphia, Pa.

NAM
56-18 Myrtle Ave.
Ridgewood 27, Queens, N
Y.

NPC
c/o Fenway Dist.
1601 5th Ave.
Pittsburgh, Pa.

NRC
2871 E. Ponce de Leon
Decatur, Ga.

NRM
234 Forbes Ave.
Pittsburgh, Pa.

NA-R-CO
See NRC

NABOR
243 S. Summit St.
Indianapolis, Ind.

NACIO
1739 DeCamp Dr.
Beverly Hills, Calif.

NAME
See CIRCA

NAN
Cappe Ent.
Chicago, Ill.

NASCO
See Nashboro

NASHBORO
177 3rd Ave. No.
Nashville, Tenn.

NASHVILLE
P.O. Box 115
Madison, Tenn.

NEALE RECORDS
P.O. Box 3294
San Bernadino, Calif.

NERO
50 E. Oak St.
Chicago, Ill.

NEW ART
See Vee-Jay

NEW PHOENIX
P.O. Box 12
Hartland, Wisc.

NEW STAR
Goodlettsville, Tenn.

NEW VOICE
See Amy-Mala

NEW WORLD
610 Pennis
Houston, Tex.

NEWAY
75 Front St., Bklyn, N.Y.

NEWPORT
See King

NICETOWN
6600 N. Broad
Philadelphia, Pa.

NIKE
7601 "S" St.
Chicago, Ill.

NILE
7120 O Street
Sacramento, Calif.

NIPPON COLUMBIA
Time & Life Bldg.
Room 4052
N.Y.C.

NOB
6727 1st Ave.
St. Petersburg, Fla.

NOCTURNE
International City
Miami Springs, Fla.

NOLA
See Instant

NONSUCH
See Electra

NORELL
See Vee-Jay

NORCO
119 S. Sam Houston
San Benito, Texas

NORGOLDE
1164 E. Sloeum St.
Philadelphia, Pa.

NORK
c/o Music Suppliers
75 N. Beacon St.
Boston, Mass.

NORMAN
1914 Washington
St. Louis, Mo.

NORTH WAY
P.O. Box 18
Ionia, Mich.

NOSLEN
4200 Mission Ave.
E. St. Louis, Ill.

NOVEL
40 Red Bird
1619 B'way

NU-TONE
See Masters, Inc.

NUCLEAR
1248 Broadway
Columbus, Ga.

NUGGETT
Route 1, Box 400
Goodlettsville, Tenn.

O'DELL
See Herald

OCTAVE
See ABC-Paramount

OFFBEAT
1340 Connecticut Ave.
Washington, D.C.

OKEH
See Epic

OLD TOWN
1697 Broadway, N.Y.C.

OLYMPIA
See Jamie-Guyden

OMEGA
P.O. Box 558
N. Hollywood, Calif.

OMEN
See A & M

OMNIBUS
See Circa

ON TAP
P.O. Box 164
Pacific Grove, Cal.

ONE-DERFUL
1829 S. Michigan Ave.
Chicago, Ill.

OPEN
See Loadstone

OPERATORS
770 Lexington Ave.,
N.Y.C.

OP'S
355 Madison Ave.
New Milford, N.J.

ORANGE-EMPIRE
8907 Wilshire Boulevard
Beverly Hills, Calif.

ORCHID
4139 Bronxwood Ave.
Bronx, N.Y.

ORDELL
See Jay-Gee

ORIGINAL SOUND
8510 Sunset Blvd.
Hollywood, Calif.

ORPHEUM
235 W. 46 St.
N.Y.C.

PJ
See Rhythm Int'l

P-K-M
See London

PACIFIC COAST
1774 N. La Brea
Hollywood 46, Calif.

PACIFIC JAZZ
3715 W. 3rd
Hollywood, Calif.

PAK
See Rust

PALACE
928 Western Saving
Fund Bldg.
Broad & Chestnut
Philadelphia, Pa.

PALETTE
1733 Broadway, N.Y.C.

PALISADE
P.O. Box 226
Danville, Ky.

PALISADES
Englewood Cliffs, N.J.

PALM
See Criterion

PALOMAR
See London

PAM
852 E. 63rd St.
Chicago, Ill.

PAN
959 Main
Buffalo, N.Y.

PANART
276 Park Av. So., N.Y.C.

PANETTE
320 W. 55th St., N.Y.C.

PANTHER
1501 Broadway, N.Y.C.

PARK AVE.
6201 Santa Monica Blvd.
Hollywood, Calif.

PARKER
See MGM

PARKTOWNE
19th & Ritner
Philadelphia, Pa.

PARKWAY
See Cameo

PARLIAMENT
See Artia

PARROTT
See London

PART
See Jay/Gee

PARTHENON
See Athens of the South

PASTEL
3750 Hemphill
Ft. Worth, Texas

PAT
1650 Broadway, N.Y.C.

PAT MAK
320 W. 55 St.
N.Y.C.

PATHE
1721 Broadway

PAXLEY
6365 Selma Ave.
Hollywood, Calif.

PEACH
P.O. Box 147
Louisville, Ga.

PEACOCK
2809 Erastus St.
Houston, Texas

PEBBLE
c/o MASTERS, INC.
8290 Sunset
Hollywood, Calif.

PEE VEE
See Brenne

PELHAM
See MVM

PEN
13 N. Manassas St.
Memphis, Tenn.

PENNANT
1207 Horn Ave.
Hollywood, Calif.

PENTHOUSE
720 Baker St.
San Francisco, Calif.

PENTHOUSE
See Sanwayne

PEORIA
6355 Yucca
Hollywood, Calif.

PERFECT
See Epic

PERISCOPE
89 Hollingsworth St.
Boston, Mass.

PERSONALITY
30 W. 60th St., N.Y.C.

PETAL
Drawer 90
Southern Pines, N.C.

PETER PAN
See Ambassador

PHAROS
6290 Sunset Blvd.
Hollywood, Calif.

PHI-DAN
See Philles

PHIL SPECTOR
See Philles

PHILIPS
35 E. Wacker Drive
Chicago, Ill.

PHILLES
440 E. 62nd, N.Y.C.

PHILLIPS INT.
639 Madison Ave.
Memphis, Tenn.

PIC #1
See Jamie

PICKWICK
8-16 43rd Av., L.I.C., N.Y.

PIECES OF EIGHT
3263 Oakdell Rd.
North Hollywood, Calif.

PIK
See Kip

PIKE
See Jay-Gee

PINK
See Ace

PIONEER
2050 Ludlow St.
Phila., Pa.

PIROUETTE
See Ambassador

PIT
5652 Daniels Ave.
Dallas, Texas

PLATEAU
See Cameo

PLAZA
8833 Sunset Blvd.
Hollywood, Calif.

PLEASANT-PEASANT
See Re-Car

JAIRO RECORDS
and
JAVEL MUSIC PUBLISHERS
are proud to release,
in the near future,
three great singles hits:
"As Long As You Love Me"
b/w "My Southern Belle"
(country & western)
*
"I'm So In Love With You"
b/w
"I Bought A Red Mustang"
(r&b*pop)
*
"Mi Gloria" b/w
"Sone Que Te Tenia en
Mis Brasos Boleros"
*
For further info,
Dealers & DISTRIBUTORS
please contact:
JAIRO RECORDS
610 So. Verdugo Rd.
Suite #3
Glendale, Calif.
Tel: 246-9445
Code 213
Promotional Copies
Available For Distr.
Throughout The U.S.A.
Please Inquire

FOR
THE
FIRST
TIME
IN
YIDDISH
**FIDDLER
ON THE
ROOF**
TIKVA RECORDS



1650 BROADWAY
NEW YORK, N.Y.
JU 6-4934

(Continued on page 48)



ROBERT GOULET

Direction:
CMA

Management:
ROSEMONT
THE PLAZA



ENTERPRISES INC.
NEW YORK

Public Relations
the
merrick
company

RECORD MANUFACTURERS

(Continued from page 46)

PLEDGE
806 S. Sixteenth St.
Wilmington, N.C.

POLKALAND
2318 Saemann Ave.
Sheboygan, Wis.

POLLY
4542 Live Oak
Mesquite, Tex.

POP
P.O. Box 548
Imperial, Calif.

POPLAR
1697 Broadway, N.Y.C.

PORT
See Jubilee

PORWIN
148 W. 125th St., N.Y.C.

POSH
1255 Post St.
San Francisco, Calif.

POWERTREE
144 W. 57th, N.Y.C.

PREMIER
366 W. 40th St., N.Y.C.

PREMORE
1647 E. 75th St.
Chicago, Ill.

PRESIDENT
See London

PRESS
See London

PRESTIGE
203 S. Washington Ave.
Bergenfield, N.J.

PRI
2886 Golden Ave.
San Bernadino, Calif.

PRIDE
See Plaza

PRIMA
279 E. Warm Springs
Las Vegas, Nev.

PRINCE
See Criterion

PROCESS
459 Wiley Ave.
Franklin, Pa.

PROGRESS
c/o Celeste

PROMENADE
See Ambassador

PROSCENIUM
See Music Minus One

PROTONE
2847 Effie St.
Los Angeles, Calif.

PROVIDENCE
See Laurie

PROWLIN
2845 W. Pico
Los Angeles, Calif.

PURDY
1721 Broadway, N.Y.C.

PURE GOLD
c/o Fernwood
297 N. Main St., Memphis

PYRAMID
6417 W. 84th St.
Los Angeles, Calif.

QQ
526 Mesilla St. N.E.
Albuquerque, N.M.

QUALITY
380 Birchmont Rd.
Toronto 13, Ont., Can.

QUAKERTOWN
See Constellation

QUEEN
See King

QUICK
364 N. Madison
Pasadena, Calif.

RCA VICTOR
155 E. 24th St., N.Y.C.

R & L
General Delivery
Big Sur, Calif.

RODG
c/o A & L
1819 Fairmount
Philadelphia, Pa.

PROGRESS
c/o Celeste

RPC
See CIRCA

RPM
9317 W. Wash. Blvd.
Culver City, Calif.

RSVP
1619 Broadway, N.Y.C.

RVA
1650 Broadway, N.Y.C.

RADAR
375 West End Ave.,
N.Y.C.

RADIANT
See Era

RADIANT
61 S. Orange
South Orange, N.J.

RAE COX
See Enrica

RAGE
1149 N. Las Palmas
Hollywood, Calif.

RAINBOW
c/o Chips Dist.
808 N. Broad St.
Philadelphia, Pa.

RAINBOW
285 Huntington Ave.
Boston, Mass.

RAINCOAT
1489 Vine St.
Hollywood, Calif.

RAINES
See Amaker

RAM
2816 Greenwood Rd.
Shreveport, La.

RAMA
See Roulette

RAMCO
3830 N. 7th St.
Phoenix, Ariz.

RAMPART
5004 Melrose Ave.
Hollywood, Calif.

RANDY
See CIRCA

RAVEN
801 17th Ave. S.
Nashville, Tenn.

RAY STAR
See Skyla

RAYCO
1549 N. Vine St.
Hollywood, Calif.

RAYNARD
See U.S.A.

RAYNOTE
6331 Hollywood Blvd.
Hollywood, Calif.

RAZORBACK
817 Cherry Pl.
Muskogee, Okla.

RE-CAR
2948 1st Ave., S.
Minneapolis 8, Minn.

RE-NO
2055 Valentine Ave.
Bronx, N.Y.

REALM
310 Madison, N.Y.C.

REBEL
297 N. Main St.
Memphis, Tenn.

RECORD LAND
13673 Wales
Oak Park, Mich.

RECORD OF KNOWLE
See Continental

RECORDO
6359 Selma Ave.
Hollywood, Calif.

RED-BIRD
1619 Broadway, N.Y.C.

RED FOX
2012 Noble St.
Pittsburgh, Pa.

RED FOX
Box 3183
Hollywood, Calif.

REDCOAT
1600 N. LaBrea
Hollywood, Calif.

RED FEATHER
Box 3, Belen, N.H.

REDSTART
311½ E. Carol
Phoenix, Ariz.

RED WING
4209 Maine Ave.
Baltimore, Md.

REECE-RAWSON
424 S-W 26
Oklahoma City 9, Okla.

REEF
6227 Delmar
St. Louis, Mo.

REEL
See Time

REGAND
2745 Filer Pl.
Los Angeles, Calif.

REGENCY
6000 Sunset Blvd.
Hollywood, Calif.

REGENT
See Savoy

REGINA
2742 E. Tremont Ave.
New York, N.Y.

REL
9116 Cimmaron
Los Angeles, Calif.

REM
See Timber

REMINGTON
See Continental

RENDEZVOUS
6367 Selma Ave.
Hollywood, Calif.

RENNER
P.O. Box 5275
San Antonio, Texas

REO TAHITI
See Criterion

REON
P.O. Box 11585
Oklahoma City, Okla.

REPEAT
5782 E. 2nd St.
Long Beach, Calif.

REPRISE
See Warner Bros.

REQUEST
66 Mechanic St.
New Rochelle, N.Y.

RESCUE
1916 Fairbanks Road
Baltimore 9, Md.

REV
3703 N. 7th Ave.
Phoenix, Ariz.

REVELLE
P.O. Box 669
Hollywood, Calif.

REVERB
See CIRCA

REVIVE
951 Perkins Ave.
Waukesha, Wisc.

REVOLVO
1432 N. Wilcox
Hollywood, Calif.

REVUE
5408 Aberdeen Ave.
Chicago, Ill.

REX
729 Park Ave.
Covina, Calif.

REXFORD
6223 Selma Ave.
Hollywood 28, Calif.

RHYTHM INT'L
250 W. 57th, N.Y.C.

RIC
801 16 Ave. So.
Nashville, Tenn.

RIC TIC
See Golden World

RICAR
1650 Broadway, N.Y.C.

RICE
812 16th Ave.
S. Nashville, Tenn.

RICH
P.O. Box 368
Nashville, Tenn.

RICHCRAFT
2314 63rd St.
Brooklyn, N.Y.

RICHIE
P.O. Box 961
Wilmington, Dela.

RICHMOND
539 W. 25th St., N.Y.C.

RIDDLE
Huntington Bldg.
Miami, Fla.

RIDER
33 34th St.
Brooklyn, N.Y.
N.Y.C.

RIDGEWAY
6087 Sunset Blvd.
Hollywood, Calif.

RING-A-DING
8425 Melrose
Hollywood, Calif.

RING-O
1697 B'way
N.Y.C.

RIO
170 W. 74th St., N.Y.C.

RITA
2158 Union Ave.
Memphis, Tenn.

RITE
9745 Lockland Rd.
Cincinnati, Ohio

RIVERSIDE
235 W. 46th St., N.Y.C.

RIVIERA
See U.S.A.

RIVOLI
See Legend

ROBBEE
Carlton House
Pittsburgh, Pa.

ROBBINS
713 18 Ave. So.
Nashville, Tenn.

ROBIN
1016 Baltimore Ave.
Kansas City, Mo.

ROCK-IT

ROCK-II 958 W. Edgem
San Bernadino, Cal.

ROCKIN'
See Scepter

RODEO
3423 Bathurst St.
Toronto, Canada

ROMA
1 Lowland Dr.
Nyack, N.Y.

ROME
See Triodex

RON
P.O. Box 14602
Baton Rouge, La.

RON-JAC
1020 Lawrence Ave.
Chicago, Ill.

RONA
1739 De Camp Dr.
Beverly Hills, Calif.

RONDO
5104 Hudson Blvd.
West New York, N.J.

RONO
118 Maplewood
San Antonio, Texas

ROOMATE
113-14 72 Rd.
Forest Hills, N.Y.

ROOST
See Roulette

RORI
75 E. 55th St., N.Y.C.

ROSE
Box 34, Decatur, Ga.

ROSEMART
See Atlantic

ROTATE
See Amy

ROTARY
Hoisington, Kansas

ROULETTE
1631 Broadway, N.Y.C.

ROUND
4410 Greenmeadow Dr.
Long Beach, Calif.

ROWE
1614 E. State St.
Trenton, N.J.

ROXIE
235 N.W. 57th Ct.
Miami 44, Fla.

ROYAL
2871 E. Ponce DeLeon
Atlanta, Ga.

ROYALTY
P.O. Box 2191
Lansing, Mich.

ROYO
See Atlantic

RUBY
20 E. 17th, N.Y.C.

RUBY
c/o Kingston

RUBYTONE
10910 S.E. Foster Rd.
Portland, Ore.

RUFUS
See Home Of The Blues

RUMAC
P.O. Box 2067-D
Pasadena, Calif.

RUMBLE
1129 Vermont Ave., N.W.
Washington, D.C.

RUNNING BEAR
See London

RURAL RHYTHM
P.O. Box 521
Arcadia, Calif.

RUSH
238 Penn Ave.
Rocky Mount, N.C.

RUSS-FI
1800 N. Argyle
Hollywood, Calif.

RUST
See Laurie

HIT ARTISTS from JAMIE/GUYDEN

BARBARA MASON

DALE & GRACE

BARBARA LYNN

THE VOLCANOS

DUANE EDDY

KENNY GAMBLE



JAMIE/GUYDEN DISTRIBUTING CO.
PHILADELPHIA, PENNSYLVANIA 19123

(Continued on Pg. 50)

**SINCERE
THANKS AROUND
THE WORLD
FERRY COMPANY**



RECORD MANUFACTURERS

(Continued from Pg. 48)

- RUSTONE**
P.O. Box 656
Houma, La.
- RY-AN**
c/o I-Nez
13 Hinkley Ave.
Ridley Park, Pa.
- S&M**
Box 3065
San Jose, Calif.
- S.S.J.**
5215½ W. 20 St.
L.A., Calif.
- S.U.R.**
444 6th St.
S.F., Calif.
- S&R**
16508 So. Main St.
Gardena, Calif.
- SPQR**
See London
- ST/AND**
105 W. 55th St., N.Y.C.
- SABINA**
See Canadian American
- SABLE**
2224 Belvedere Dr.
Jackson, Miss.
- SABRE**
c/o Rollie
116 W. 72nd St., N.Y.C.
- SACRED**
550 W. Lambert Rd.
P.O. Box 3035
Whittier, Calif.
- SAGE AND SAND**
5653½ Hollywood Blvd.
Hollywood 28, Calif.
- SALCO**
c/o Sam Bushman
22nd & Walnut
Philadelphia, Pa.
- SALE**
See Globe
- SALEM**
111 Main St.
Salem, Va.
- SAMTER**
522 Lafayette St.
Gretna, La.
- SAN-DEE**
212 N. 12th St.
Philadelphia, Pa.
- SANDRU**
624 Kings Highway
Brooklyn, N.Y.
- SANDY**
P.O. Box 248
Mobile, Ala.
- SANSU**
See Amy
- SANTAVILLE**
P.O. Box 146
Salt Lake City, Utah
- SANWAYNE**
Box 433
Forrest Park, Ga.
- SAPIAN**
See Acclaim
- SAR**
6425 Hollywood Blvd.
Los Angeles, Calif.
- SARA**
See Cuca
- SATURN**
See Bomarc
- SAVOY**
56 Ferry St.
Newark, N.J.
- SAXONY**
P.O. Box 177
Cincinnati, Ohio
- SCARLET**
See London
- SCEPTER**
1650 Broadway, N.Y.C.
- SCO-INA**
2402 Ave. R
Brooklyn, N.Y.
- SCOOPE**
See Posh
- SCOTTE**
4834 Bissell Ave.
Richmond, Calif.
- SCOTTIE**
Cornelia, Ga.
- SCOUT**
See Crystalette
- SEA-HORN**
See Arnold
- SEAFAIR**
See CIRCA
- SEDCO**
P.O. Box 148
Elsinore, Calif.
- SEECO**
39 W. 60th St., N.Y.C.
- SEGWAY**
1650 Broadway, N.Y.C.
- SELECT**
See Joy
- SELSOM**
43 Broad St.
Red Bank, N.J.
- SENATOR**
P.O. Box 4104
Sacramento, Calif.
- SEVENTEEN**
World Wide
1650 Broadway, N.Y.C.
- SEVILLE**
See London
- SHAH**
See Jay-Gee
- SHALIMAR**
1314-24 S. Howard
Philadelphia, Pa.
- SHAMROCK**
1310 S. New Hampshire
Los Angeles, Calif.
- SHAR**
6128 W. Belmont Ave.
Chicago, Ill.
- SHAR-DEE**
c/o Hansen
1842 West Ave.
Miami Beach, Fla.
- SHARON**
Box 2343
Hollywood, Calif.
- SHARP**
See Savoy
- SHASTA**
4720 Forman Ave.
Hollywood 8, Calif.
- SHEEN**
121 E. Olive Ave.
Monrovia, Calif.
- SHELL**
157 W. 57th St., N.Y.C.
- SHEP**
See Shor
- SHEPHERD**
7215 Hillside Ave.
Hollywood, Calif.
- SHERATON**
355 Madison Ave.
New Milford, N.J.
- SHERWOOD**
See CIRCA
- SHERYL**
c/o Ross Assoc.
250 S. Broad St.
Philadelphia, Pa.
- SHIRLEY**
43465 Sweetwood St.
Fremont, Calif.
- SHOMAR**
2306 Louisiana
Houston, Texas
- SHOW**
See Globe
- SHOWBOAT**
P.O. Box 955
Nashville, Tenn.
- SHOWCASE**
See Monument
- SHOWCASE**
See Michelle
- SHREVE**
P.O. Box 1063
Shreveport, La.
- SIGNET**
See CIRCA
- SILVER LEAF**
See Honor
- SILVERS**
201 Br'tn. First Road
Brooklyn, N.Y.
- SIMON SAYS**
33-44 Whalen Rd.
E. Rutherford, N.Y.
- SIMS**
801 17th Ave., S.
Nashville, Tenn.
- SKIPPY**
Box 311
Kleberg, Texas
- SKY**
P.O. Box 9162
Jackson, Miss.
- SKYLA**
1549 N. Vine St.
Hollywood, Calif.
- SKYLAR**
See Era
- SKYLARK**
5109½ Hollywood Blvd.
Los Angeles, Calif.
- SKYLITE**
209 N. Lauderdale
Memphis, Tenn.
- SKYLITE**
133 S. Atlantic Blvd.
Compton, Calif.
- SKYROCKET**
1739 N. 3rd St
Philadelphia, Pa.
- SKYWAY**
Box 133
Hollywood, Cal.
- SLEEPER**
Box 662
Meridian, Miss.
- SLEEPER**
Box 662
Meridan, Miss.
- SLIDE**
See Lorraine
- SMASH**
35 E. Wacker Dr.
Chicago, Ill.
- SMILE**
See CIRCA
- SMOKEY**
P.O. Box T-5037
Mobile, Ala.
- SO DESKA**
177 Beach 141 St.
Belle Harbor, N.Y.
- SOCK**
See Target
- SOFT**
See Jamie
- SOLID GOLD**
713 18th Ave. S.
Nashville, Tenn.
- SOMA**
119 N. 9th Ave.
Minneapolis, Minn.
- SOMERSET**
See Miller Int'l
- SON-BERT**
See Correct-Tone
- SONG BIRD**
See Duke
- SONG HITS**
See Hit Parader
- SONJA**
4263 Olymiad Dr.
Los Angeles, Cal.
- SONODOR**
See Miller Int'l
- SOOZEE**
See CIRCA
- SOUL**
See Tamla
- SOULVILLE**
234 Auburn Ave.
Atlanta, Ga.
- SOUND-O-RAMA**
7056 Lanewood Ave.
Hollywood, Calif.
- SOUND STAGE-7**
See Monument
- SOUNDEX**
See Ron
- SOUNDS OF ATLANTA**
524 Plasters Ave. N.E.
Atlanta, Ga.
- SOUTHERN SOUND**
250 W. 57 St.
N.Y.C.
- SOUTHLAND**
520 St. Louis St.
New Orleans, La.
- SOUTHSIDE**
1650 Broadway, N.Y.C.
Southtown
- SOUVENIR**
226 Sherman Ave.
Coeur D'Alene, Idaho
- SPACE**
1016 Apache
Houston, Texas
- SPAN**
c/o Circa
- SPAR**
P.O. Box 7663
Nashville, Tenn.
- SPARK**
see London
- SPARTAN**
111 Mack Ave.
Detroit, Mich.
- SPARTON**
P.O. Box 5053
London, Ont., Canada
- SPECIAL**
See Globe
- SPECIALTY**
8300 Santa Monica Blvd.
Hollywood, Calif.
- SPECTATOR**
c/o Allied
2437 E. 57th St.
Los Angeles, Calif.
- SPHERE SOUND**
See Amy
- SPIDER**
Box 885
Ashland, Ky.
- SPIN**
P.O. Box 518
Scottsdale, Ariz.
- SPINNING**
510 N. Dearborn St.
Chicago, Ill.
- SPIRAL**
875 5th Ave., N.Y.C.
- SPOKANE**
See Scepter
- SPORT**
1916 Fairbanks Rd.
Balt. 9, Md.
- SPOT**
1053 Lynn Garden Dr.
Kingsport, Tenn.
- SPOTLITE**
2 Geary St.
S.F., Calif.
- SPRINGBOARD**
2318 Coles Blvd.
Norristown, Pa.
- SPRUCE**
N.Y.C.
- SPRY**
6000 Sunset Blvd.
Hollywood, Calif.
- STACY**
1918 Prairie Ave.
Chicago, Ill.
- STADIUM**
Box 38631
Hollywood, Calif.
- STAGEDOOR**
58 Dayton Ave.
Passaic, N.J.
- STAGG**
#10 Marlo Dr.
Belleville, Ill.
- STALLION**
1650 B'way
N.Y.C.
- STANTON**
c/o Song Shop
36 E. 5th St.
Cincinnati, Ohio
- STAR-A-FIRE**
151 W. 154th St.
Gardena, Calif.
- STARDAY**
P.O. Box 115
Madison, Tenn.
- STARDUST**
107 E. Third St.
Mount Vernon, N.Y.
- STARDUST**
881 7th Ave., N.Y.C.
- STARFIRE**
See Celtic
- STARK**
16 Union St.
Memphis, Tenn.
- START**
See Checker
- STARTIME**
6201 Santa Monica Blvd.
Hollywood, Calif.
- STAX**
See Atlantic
- STELLAR**
550 5th Ave., N.Y.C.
- STENO-SPEED**
See Conversaphone
- STEPHENY**
510 N. Dearborn St.
Chicago, Ill.
- STEREO FIDELITY**
P.O. Box 45
Swarthmore, Pa.
- STEREOODDITIES**
259 S.W. Terrace
Ft. Lauderdale, Fla.
- STERLING**
6 Beacon St.
Boston, Mass.
- STONEWAY**
2317 Laura Koppe
Houston, Tex.
- STOP**
1820 Washington St.
Boston, Mass.
- STORK**
1650 Broadway, N.Y.C.
- STRAND**
157 W. 57th St., N.Y.C.
- STRATE 8**
3942 Third
Detroit, Mich.
- STREETCAR**
1619 Broadway
N.Y.C.
- STREKE**
See Periscope
6266 Sunset Blvd.
Hollywood, Calif.
- STRIPE**
1808 West End
Nashville, Tenn.
- STUDIO**
See 20th Fox
- STYLE**
c/o World-Wide
1674 Broadway, N.Y.C.
- STYLETONE**
1758 E. 4th St.
Bklyn., N.Y.
- SUCCESS**
165 W. 46 St.
N.Y.C.
- SUE**
265 W. 54th St.
New York, N.Y.
- SULTAN**
See Card
- SUMMIT**
1158 Skipper Dr.
Mobile, Ala.
- SUMTHIN ELSE**
3351 N. Green Bay Ave.
Milwaukee, Wis.
- SUN**
639 Madison Ave.
Memphis, Tenn.
- SUNNY**
230 N. Michigan Ave.
Chicago, Ill.
- SUNNYBROOK**
660 N. Broad St.
Philadelphia, Pa.

WANTED

Tapes or Masters
R&B... POP... C&W
For Lease

CONTACT JIM GOLDEN
U.S.A. RECORD CO.
1448 South Michigan Ave., Chicago, Ill. 60605
Phone: (312) 939-3675



Destined to be a SUPER-STAR!
IAN WHITCOMB

Thanks to everyone for making
1965 a year to remember for me.

Personal management and direction: Jerry Dennon
Jerden Music, Inc.

2227 Fifth Avenue • Seattle, Washington 98121 • MAIN
2-0470

A Tower Records artist. Bookings: GAC.

SOUL
See Tamla

(Continued on Pg. 52)

ARTHUR HOWNES

TOP PROMOTIONS and ARTISTES MANAGEMENT
PRESENTING THE WORLD'S TOP STARS

in
EUROPE

and in
UNITED STATES



EROS HOUSE

29-31 REGENT STREET — LONDON - S.W. 1 ENGLAND

TELEPHONE: REGENT - 5202

CABLES: POPSHOWS LONDON S.W. 1

MUSIC of MANY LANDS

AMERICA'S LEADING
MANUFACTURER OF
INTERNATIONAL ALBUMS
OUTSTANDINGLY PACKAGED
AND DESIGNED—

FEATURING:

ARABIC
CZECH
FRENCH
GERMAN
GREEK
GUIANIAN
GYPSY
IRISH
ISRAELI
ITALIAN
JAPANESE
JEWISH
KOREAN
LATIN
LITHUANIAN
MEXICAN
POLISH
PORTUGUESE
RUSSIAN
SCOTTISH
SPANISH
TURKISH
UKRANIAN
YUGOSLAVIAN
and
WEST INDIAN

"The Finest High Fidelity
in Stereo and Monaural"

**REQUEST RECORDS
Inc.**

66 MECHANIC ST., NEW ROCHELLE, N. Y.

TELEPHONE: 914 NE 3-6059

RECORD MANUFACTURERS

(Continued from Pg. 50)

SUNSHINE
2210 Sam Wilson
Houston 20, Texas

SUPREME
See Detroit

SURE
Box 94
Broom Hall, Pa.

SURE-FIRE
319 Seventh Ave., N.
Nashville, Tenn.

SURE-SHOT
See Duke

SURFARI
1312 W. Garvey
Monterey Park, Calif.

SURFSIDE
2805 Biscayne Blvd.
Miami 37, Fla.

SUTTON
1023 N. La Brea
Hollywood, Calif.

SWA-RAY
756 7th, N.Y.C.

SWADE
See Trace

SWALLOW
See Jin

SWAN
N.W. Corner 8th &
Fitzwater St.
Philadelphia, Pa.

SWAY
See Empire

SWINGIN'
See CIRCA

SWINGLINE
P.O. Box 3164
Shreveport, La.

SYMBOL
See Sue

T-NECK
See Atlantic

TCF
See 20th-Fox

TNT
1422 W. Poplar
San Antonio, Tex.

TAB
1121 Market
Galveston, Tex.

TAD
8 E. 48th St., N.Y.C.

TAG
659 10th Ave., N.Y.C.

TAHITI
See Criterion

TAHOE
See London

TAKE TEN
360 N. Michigan Ave.
Chicago, Ill.

TALENT SCOUT
See CIRCA

TALLEY-HO
Commercial Trust Bldg.
Philadelphia, Pa.

TALLY
Box 842
Bakersfield, Calif.

TALMONT
4411 Gra-Mar Drive
Nashville, Tenn.

TAMLA
2648 W. Grand Blvd.
Detroit 8, Mich.

TAMM
2823 Johnston
Lafayette, La.

TAMMY
708 5th St.
Struthers, Ohio

TAMPA
1107 N. El Centro
Hollywood, Calif.

TANDA
See Martian

TANGERINE
See ABC

TAPE
See CIRCA

TAPE RECORDS
6051 Harold Way
Hollywood, Calif.

TAR-GET
2847½ W. Pico Blvd.
Los Angeles, Cal.

TARHEEL
See London

TAURUS
6510 St. Clair
Cleveland, Ohio

TEARDROP
See Jamie

TEEK
4829 Leduc
St. Louis, Mo.

TEEN
See CIRCA

TEEN-TIME
1774 No. La Brea
Hollywood, Calif.

TEENA
See Circa

TEIA
302 Vincent Bldg.
Jackson, Miss.

TELE FUNKEN
See London

TEMPE
6365 Selma Ave.
Hollywood 28, Cal.

TEMPLE
2080 Delaware
Detroit, Mich.

TEMPUS
423 First Nat'l. Bank
Bldg.
Peoria, Ill.

TEMPWOOD V
See Jay-Gee

TENOR
205 E. 42 St.
N.Y.C.

TERI DE
2243 Clyde St.
L.A., Calif.

TERON
1158 N. Highland
Hollywood, Calif.

TERRACE
See London

TERRY
772 E. McMillan St.
Cincinnati, Ohio

TEXAN
Box 935
Irving, Texas

THOR
See Nike

THREE STAR
Box 6278
Bakersfield, Calif.

THRONE
1320 Vine St.
Philadelphia, Pa.

THUNDER
See Nike

TIARA
835 Hamilton Ave.
Fort Wayne, Ind.

TIARE
See Criterion

TIC TOC
See Goldband

TICO
See Roulette

TIDAL
2513 Colby Ave.
Los Angeles, Calif.

TIDE
2146 W. View St.
Los Angeles 16, Calif.

TIFTON
c/o Ambassador

TIGER
See Red-Bird

TIGRE
2907 W. Hollywood
Chicago, Ill.

TIKVAH
1650 Broadway, N.Y.C.

TILT
See London

TILTON
See Continental

TIMBRE
1407 N.E. 47th St.
Seattle, Wash.

TIME
1290 6 Ave.
N.Y.C.

TIMES SQUARE
1104-6th Ave.
New York, N.Y.

TIP
792 E. 48th St. N.
Tulsa, Okla.

TIP TOP
See U.S.A.

TITAN
5334 Concord
Detroit 11, Mich.

TITANIC
1310 So. New Hampshire
Ave.
Los Angeles, Calif.

TODD
1719 West End Ave.
Nashville, Tenn.

TOKEN
3303 W. Ohio St.
Midland, Texas

TOLLIE
See VeeJay

TOP ROCK
2816 E. Adams St.
Phoenix, Ariz.

TOPIC
See B. Atlas

TOPIX
See London

TOPPA
729 Park Ave.
Covina, Calif.

TOPS
5810 S. Normandie
Los Angeles, Calif.

TOWER
151 W. 46
N.Y.C.

TOWN
1916 Fairbanks Rd.
Baltimore, Md.

TRACE
P.O. Box 92
Baton Rouge, La.

TRACY
1995 Parthina
Northridge, Calif.

TRADITION
80 E. 11th St., N.Y.C.

TRAIN
1201 Plymouth Ave.
Nashville, Tenn.

TRANS-WORLD
7250 Beverly Rd.
Los Angeles, Calif.

TREBCO
117 W. Capitol St.
Jackson, Miss.

TREND
P.O. Box 1647
Sumter, So. Carolina

TREPUR
Rt. 3, LaGrange, Ga.

TREY
See Atlantic

TRI
See London

TRI-ODE
1639 Broadway, N.Y.C.

TRI-PHI
592 Farnworth Ave.
Detroit, Mich.

TRIBE
See London

TRIBUTE
250 E. 51 St., N.Y.C.

TRILL
9341½ Olympic Blvd.
Beverly Hills, Calif.

TRIUMPH
See Regina

TROY
6201 Santa Monica Blvd.
Hollywood, Calif.

TRU-SOUND
See Prestige

TRUMP
1320 Armand Circle
Decatur, Ga.

TRUMPET
Box 62
Atlanta, Ga.

TRY ME
See King

TUBA
See Chess

TUFF
See Chess

TULIP
See CIRCA

TUNE
123 E. Alabama St.
St. Florence, Ala.

TUNEGLOW
Box 287
Forrest Park, Ga.

TURBAN
4811 Laurel Canyon Blvd.
N. Hollywood, Calif.

TUXEDO
132 Nassau St., N.Y.C.

TWENTIETH FOX
444 W. 56th St., N.Y.C.

TWILIGHT
P.O. Box 174
Albany, Calif.

TWIN
90-06 215th St.
Queens Village, N.Y.

TWIN HITS
See Operators

TWIN SPIN
320 Washington Ave.
Owensboro, N. Y.

TWIRL
20 W. Alexandrine
Detroit, Mich.

TWO BROS.
See Target

TYTEX
Box 3321, Tyler, Texas

U-PLAY
See Revolver

U.S.
355 Madison Ave.
Milford, N.J.

U.S. SONGS
1619 Broadway, N.Y.C.

U.S.A.
1448 S. Michigan Ave.
Chicago, Ill.

UTC
See Music Minus One

ULSYRA
35 W. 53 St.
N.Y.C.

UNIQUE
See Globe

UNIQUE
1640 S. Ridgeway
Chicago, Ill.

UNITED ARTISTS
729 7th Ave., N.Y.C.

UNITED SOUTHERN
125 Albert Pike
Hot Springs Nat'l Park,
Ark.

UNITED WORLD
6004 7th Ave.
Brooklyn, N.Y.

UNITY
1560 N. La Brea
Hollywood, Calif.

UNIVERSAL ARTISTS
232 W. 48 St.
N.Y.C.

UNIVERSITY
480 Ridgeway
Little Rock, Ark.

UPTOWN
See Tower

URANIA
233 Main St.
Belleville, N.J.

UTOPIA
1617 No. Broad St.
Philadelphia, Pa.

V.I.P.
See Tamla

VLM
950 Morris St.
Cincinnati, Ohio
(Continued on Pg. 54)

TO CASH BOX - AND THE ENTIRE TRADE,
WHO MADE IT ALL POSSIBLE - THANKS -

File Under: Lettermen • Vocal Group ST 2359

NEW IMPROVED FULL DIMENSIONAL STEREO

THE HIT SOUNDS OF **THE
LETTERMEN**

THEME FROM "A SUMMER PLACE" • YOU'VE LOST THAT LOVIN' FEELIN' • DEAR HEART
DOWNTOWN • SEALED WITH A KISS • WHEN SUMMER ENDS • DREAMIN' • SUMMER SONG
RED ROSES FOR A BLUE LADY • HAWAIIAN WEDDING SONG • IF EVER I WOULD LEAVE YOU



- And a very special thank you to Steve Douglas, our producer



Booking
WMM
WILLIAM MORRIS

Personal Management:
JESS RAND ASSOC.
Beverly Hills

National Promotion
PETE BENNETT
N.Y.C.

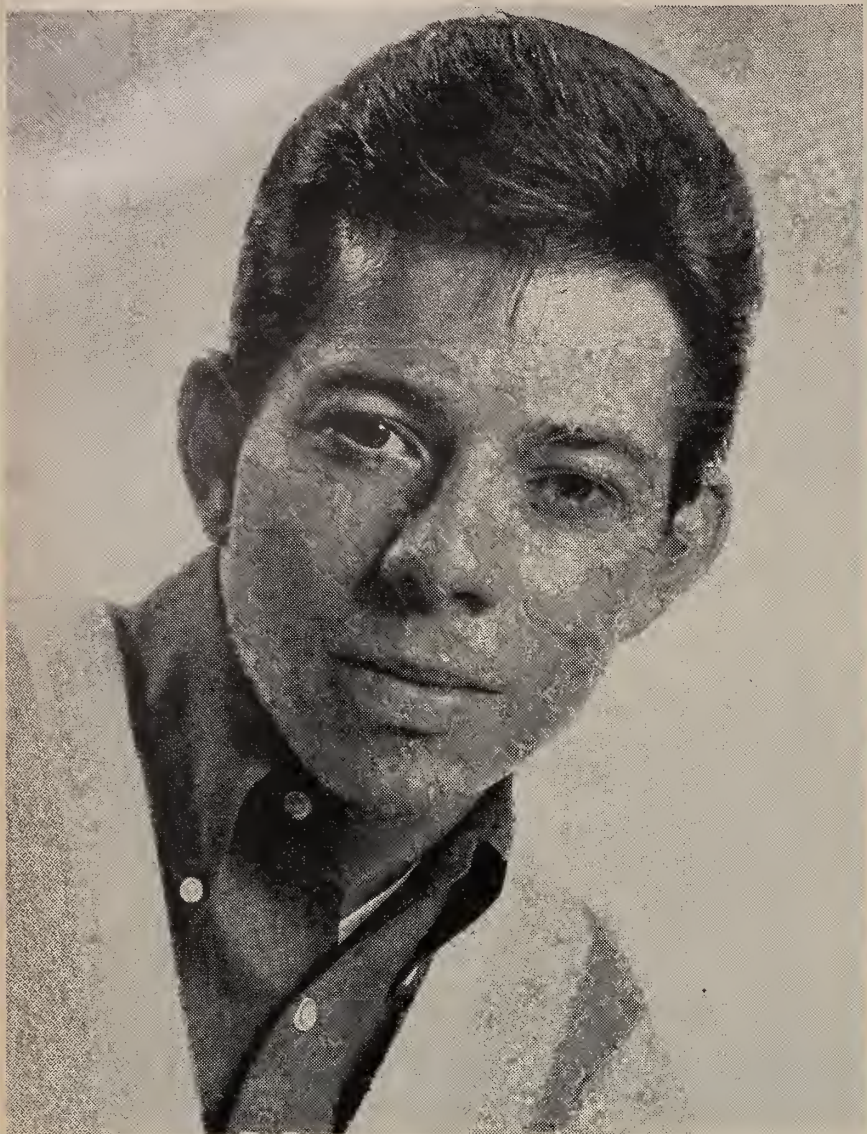

BOBBY GOLDSBORO

UNITED ARTISTS RECORDS

current single:

**"IF YOU WAIT
FOR LOVE"**

#908

current album:

"LITTLE THINGS"

LP #(M) 3425/(S) 6425

BOOKINGS:



PRESS RELATIONS:
Saul Richfield

MANAGEMENT:

LENNY DITSON
850 Seventh Ave.
New York, N.Y.

RECORD MANUFACTURERS

(Continued from Pg. 52)

VAL-HILL
406 Lincoln St.
LaGrange, Ga.

VALDOT
See Pancello

VALE
218 N. Liberty
Cherryvale, Kans.

VALERIE
c/o London

VALIANT
6290 Sunset Blvd.
Hollywood, Calif.

VALINDA
584 Richburn Ave.
La Puente, Calif.

VALLI
1813 S. William St.
South Bend, Ind.

VALMOR
225 W. 57
N.Y.C.

VAMPIRE
1128 Atlantic Ave
Atlantic City, N.J.

VANDAN
8435 Maddox Ave.
Dallas, Texas

VANESSA
841 E. 25th St.
Los Angeles, Calif.

VANGUARD
154 W. 14th St., N.Y.C.

VANITY
253 21st St.
Paterson, N.J.

VARIETY
54 W. Randolph St.
Chicago, Ill.

VEE JAY RECORDS
9056 Santa Monica Blvd.
Los Angeles 69, Calif.

VENDED
1000 Cahuenga Blvd.
Hollywood, Calif.

VENETT
1600 N. LaBrea
Hollywood, Calif.

VENUS
901-02 E. 108th St.
Los Angeles, Calif.

VERSAILLES
1650 Broadway, N.Y.C.

VERSATILE
See Wink

VERVE
451 N. Canon Dr.
Beverly Hills, Calif.

VEST
See Atlantic

VESUVIUS
See MGM

VI-WAY
See CIRCA

VIBRA
5 Woodland Ave.
Metairie, La.

VIBRO
612 15th Ave.
Belmar, N.J.

VICTORIA
See DeVille

VIK-IRO
See Astro

VIKIN
26 Glossop St.
Providence, R.I.

VIKING
P.O. Box 281
Crowley, La.

VILLA
445 Webster St.
San Francisco, Calif.

VILLA-YORE
c/o Hart Dist.
1216 W. Olympic
Los Angeles, Calif.

VILLAGE
P.O. Box 104
Long Beach, Miss.

VILLAGE GATE
See Amy

VIM
See Clock

VIN
See Ace

VIRTUE
8500 Fayette St.
Philadelphia, Pa.

VISCOJON
1812 W. 38th St.
Los Angeles, Calif.

VISCOUNT
Carlton House, Pittsburgh

VISION
1000 Burwell Bldg.
Knoxville, Tenn.

VISTA
477 Madison Ave., N.Y.C.

VITA
1486 N. Fair Oaks
Pasadena, Calif.

VITALENT
See Jay-Gee

VIV
4625 N. 50th Dr.
Phoenix, Ariz.

VIUID
1449 S. Michigan
Chicago, Ill.

VON
7558 N. 57th Ave.
Glendale, Ariz.

VOX
236 W. 55th St., N.Y.C.

VULCAN
817 Bradford,
Sherwood Terrace
Nashville, Tennessee

W-E-D
P.O. Box 25187
Los Angeles, Calif.

WGW
21 Franklin St.
Somerville, N. J.

**WALDORF MUSIC
HALL**
1501 Broadway, N.Y.C.

WAND
See Scepter

WARE
217 W. 53 St.
N.Y.C.

WARNER BROS.
4000 Warner Blvd.
Burbank, Calif.

WARNOCK
2120 Connally Dr.
East Point, Ga.

WASHINGTON
1340 Connecticut Ave.
Washington, D.C.

WATCH
See RON

WAX
577 14th St.
Oakland, Calif.

WAYNE
160 E. 48th St., N.Y.C.

WEB
See Diamond

WEBER
9015 Wilshire Blvd.
Beverly Hills, Calif.

WEDGE
3101 Fleet St.
Baltimore, Md.

WELLS
See Fargo

WES-MAR
31 W. Market
Akron, Ohio

WESTMINSTER
See ABC-Paramount

WHALE
1721 Broadway, N.Y.C.

WHEEL CITY
See Music Merchants

WHEELING
Box 902, Wheeling,
Va.

WHEELSVILLE, U.S.A.
See D-Town

WHIP
510 Anderson Ave.
Cliffside Park, N.J.

WHIPPETT
8566 Sunset Blvd.
Los Angeles, Calif.

WHIRLYBIRD
c/o Audio Arts
5607-11 Melrose Ave.
Hollywood, Calif.

WIDE
See Kingston

WILBANKS
Box 325
Baldwin Park, Calif.

WILBEE RECORDS
160 Wood Street,
Wilkes-Barre, Pa.

WILD
1820 Washington St.
Boston, Mass.

WILD DEUCE
1619 B'way
N.Y.C.

WILDCAT
1611 Broadway
San Antonio, Tex.

WILLOW
See King

WIN
27 Stegman Pl.
Jersey City, N.J.

WIN GATE
See Golden World

WINE
See Kathy

WING
See Mercury

WINLEY
208 W. 84th St., N.Y.C.

WINDSOR
See CIRCA

WINSTON
P.O. Box 1982
Abilene, Tex.

WITCH
See Cortland

WOLFIE
See Titanic

WON
6357 Selma Ave.
Hollywood, Calif.

WORD
P.O. Box 1790
Waco, Texas

WORKSHOP
See Motown

WORLD
See Robbee

WORLD ARTISTS
550 Grant St.
Pittsburgh, Pa.

WORLD PACIFIC
8715 W. 3rd St.
Hollywood, Calif.

WORLD WIDE
524 Plasters Ave.
Atlanta, Ga.

WORLD WIDE
56 Ferry St.
Newark, N.J.

WORTHY
550 5th Ave.
New York, N.Y.

WYE
625 Warwick Ave.
Warwick, R.I.

WYNCOTE
c/o Cameo Parkway

YALE
9 Jefferson Ave.
Elizabeth, N.J.

YORK
7715 Sunset Blvd.
Hollywood, Calif.

YORKTOWN
347 Litchfield Ave.
Babylon, N. Y.

YOUNG PEOPLE'S
100 Sixth Ave., N.Y.C.

YUCCA
P.O. Box 641
1507 10th St.
Alamagordo, N.M.

Z
319 N. Broadway
Poplar Bluff, Mo.

ZAB
632 Madison Ave.
Memphis, Tenn.

ZEBRA
31 Brompton Rd.
Garden City, N.Y.

ZIL
177 3rd Ave. N.
Nashville, Tenn.

ZONE
P.O. Box 4692
Memphis, Tenn.

ZOOM
See London

**THANKS DJ's
I'm Grateful
To You All
For Your
Support.**

**VOTED
#1**

**MOST PROGRAMMED
INSTRUMENTALIST
OF 1965
BY THE NATION'S
DISK JOCKEYS**

LATEST ALBUM



Personal Management:
**GERARD W. PURCELL
ASSOCIATES, Ltd.**
New York Hollywood

EXCLUSIVELY

RCA VICTOR
The most trusted name in sound



RECORD DISTRIBUTORS

AND THE LINES THEY HANDLE

ARIZONA

PHOENIX—(602)

Ariz. M. B. Krupp Dist. Inc.
2519 North 16th St.
Margo Grover—252-4013
(A&M, Amy, Argo, Cameo, Challenge, Canadian American, Chess, Checker, Coed, Colpix, Del Fi, Dooto, Duke, Everest, Fabor, Fairmont, Era, Ember, Fraternity, Garrett, G.N.P., Gordy, Hi, Herald, Hickory, Imperial, Jubilee, Laurie, Le Grand, London, Minit, Mantel, Motown, Old Town, Parkway, Phyllis, Specialty, Starday, Sue, Sun, Swan, Tamla, 20th Fox, Vee Jay, Wand, Command, Grand Award, ABC Paramount, Almo, Autumn, Backbeat, Big Top, B. T. Puppy, Canja, Cedwicke, Chart, Chattahoochee, Chancellor, Constellation, Country, Country Capers, Crest, Crusader, Diamond, Donna, Derby, Dial, Dimension, Dote, Duncon, Dunes, Fame, Fernwood, Flip, Galaxy, Gold Wing, Guyden, Harvey, Highland, Interphon, Jamie, Johnson, Josei, Joy, Kent, Lute, Mala, Marc, Mar-v-Lus, Mascot, Melody, Michelle, Milestone, MOC, Monza, Nan, No-Mar, Norco, Onderful, Parrott, Petal, Pramm, Red Bird, Ric, Rice, Sims, SPQR, Symbol, Tag, Talamo, Tangerine, Teardrop, Todd, Tollie, Toppa, Tower, Trend, Tuff, Unical, World Artists, World Arts.)

CALIFORNIA

GARDENA—(213)

Alamo Records
16508 So. Main St.
(Eco, Peerless, Sagard.)
Area codes follow cities

LOS ANGELES—(213)

Allied Music Sales
2542 West Pico
Guy Cook—DU 4-3154
(Asco, Bartok, Classic, Editions, Collectors Guild, Composers Recording Inc., Connoisseur Society, Cook, Dimso, Discomodo, Documentary, Fuentes, Gema, Maya, Miami, Orfeon, Period Scala, Stradivari, Tab, Tikva, Tradition, UTC, Cymbal.)

Allied Record Sales Co.

2437 East 57th St.
213-582-0841
(Lines not available at press time)

Budget Sound Co.

2818 West Pico Blvd.
Al Sherman—RE 1-9474
(Somerset, Stereo, Fidelity.)

California Record Dist.

3009 West Pico Blvd.
Ralph Kaffel—RE 1-8601
(Argo, Arvee, Audicon, Blue Note, Checker, Chess, Crackerjack, Del Fi, Derby, Donna, Debut, Everest, Fantasy, Fleetwood, Folklore, Galaxy, Golden, Hi Fi, Holt, Legrand, Lehrer, Laurie, Life, Merri, Mr. Maestro, New Jazz, Pacific Jazz, Peerless, Prestige, Rust, Sor, Sermon, Sue, Symol, Sounds, Tuff, World Pacific, Red Bird, AA, Aura, Broadway, Calico, Counterpoint, Concerdisk, Eco, Eastern Esoteric, Mohawk.)

Capitol Records Dist. Corp.

3117 San Fernando Road
W. L. Tappan—CL 7-8224
(Capitol, Angel)

Chapman Dist.

2645 West Pico Blvd.
Al Chapman—385-3636
(Angel-Town, Arc, Bellina, Cabot Language, Celestial, Chattahoochee, Children's Record Guild, Cobra, Deville, Jox, Dewl, Fantasy Films, Kem, Like Young, Living Language, International Artists, Milestone, Motivation, Phil's, Protone, Rem, Section, Young People's Records, Whirlybird.)

Clef Dist.

2847 West Pico Blvd.
375-1394
(Aerfaun, Allector, American Art, Artia, Azteca, Barogne, Bego, Bronjo, Calla, Charger, Chex, Conversephone, Cri, Crs, Del Valle, DeMarco, Desto, Dictation, Disc, Discos Columbia, Downey, El Zarape, Eurotone, Exito, FG, Falcon, Faro, Folkways, Fuentes, Gen. Amer. Goliath, Gregorian, Jerden, J-Gems, Josie, Marvel, Misty, M.K., Mobile Fidelity, Monitor, Musart, Music Minus One, Nins, Nortena, One-derful, Orfeon, Parliament, Paula, Port, B. T. Puppy, Rally, Rampart, Revis, Ring, Ruff, Sabra, Seeco, Sims, Sombrero, Starday, Stereoditties, Supraphon, Tam-bura, Todd, Tropical, Wassel, World Artists)

Columbia Record Dist.

2120 So. Garfield
Ted Rosenberg—723-9511
(Columbia, Masterwork Phonos.)

CREATIVE SOUND

9000 Sunset Blvd.
CR-1-4843
(Altar, Audio Bible, Creative Sound, Gospel Singtime, Kingsway.)

Decca Dist. Corp.

6750 Santa Monica Blvd.
Lou Verza—HO 3-7126
(Decca, Coral, Brunswick, Vocalion, Listen and Learn.)

Diamond Dist. Co.

2990 West Pico Blvd.
Abe Diamond—RE 1-6311
(ABC Paramount, Mahala, Impulse, Waikiki, Fraternity, Music Guild, Brent, Tangerine, Shad, Apt, Command, Big Top, Grand Award, Grand Prix, Nippon, Time, Westminster.)

Dot Records Inc.

2596 West Pico Blvd.
Dick Carpenter—DU 7-8127
(Dot, Hamilton)

Hart Dist. Inc.

1845 Orchard
G. D. Harlstone—784-2281
(Liberty, Disney, London, Orig. Sound, Warner Bros., Monument.)

Hector Dist. Co.

17628 Nordhoff Street
Northridge.
Don Burke—886-1670
(Aeolian-Skinner, Academy, Austin, Audiophile, Bert & L. Bartok, Boston, Cantote, Cook, Dorian, Educo, Evergreen, Fidelity Sound Recordings [FSR], Haydn Society, Lexington, MEA, Music Library, Murrill, Piedmont, Rococo, Southland, Spa, Spoken Arts, Toad, Ultraphone.)

HIT RECORD SALES

1607 EL CENTRO
HO 2-0261
(Bolo, Celestial, DeVille, Empala, Glenn, Magnet, Virgelle.)

Hitsville Inc.

3009 West Pico Blvd.
Ralph Kaffel—RE 1-8601
(Tomlo, Motown, Gordy, Melody, Soul, V.I.P.)

L & S Record Supply Co.

1310 S. New Hampshire Ave.
Sid Tabak—DU 4-2597
(Ariel, Arrowak, Babytown, Beechwood, Bronze, Courier, Cobra, Chroma, DW, Debonair, Excell, Fortune, Franc, Folkart, Glen, Hollywood A Go Go, J&S, Juggy, Joeli, Leda, Lulu, Leadstone, My Time, Minaso, Musette, Nanc, Rotate, Starla, TW, TL, Thurbi, Wild Deouce, Zell.)

Merit Dist. Co.

2800 West Pico Blvd.
Jack Lewerke—RE 1-8791
(Aero, Ace, Ara, Autumn, Backbeat, Blaum, Brooklyn, Cash, Celeste, Chief, Contemporary, Dance Along, Destination, Dial, Douglas, D-Town, Excell, Flash-back, Focus, Gallio, Gee-Kay, Glory, Golden Wing, HammeK, Hanna-Barbara, Heidi, Ibis, Instant, Inunity, Ivanhoe, Jerk, Keetch, L.G., Little Mark, Look Up, Last Night, Lucky Token, Lupine, Nanesuch, Peacock, Phi-Dan, Pico, Princess, Request, Rosemart, Satellite, Shirley, Somo, Song-Bird, Sureshot, Timbre, Tuba, Unity.)

Metro Record Dist.

2053 Venice Blvd.
Mel Price/Gene Walkin—733-2114
(MGM, Verve, Audio Fidelity, Deutsche Grammophon, Story Time.)

Modern Dist. Co.

2978 West Pico Blvd.
Bunny Hirsch—RE 3-2174
(Arc, Assoc. Artists, Cabot, Calico, Cantote, Chattahoochee, Children's Guild, Crest, D'Arcy, Del Amo, Dingo, Durco, Fernwood, Gallant, Gambit, Jolum, Ideal, Julie, Lyrichord, Living Language, Living Literature, Merri, Milestone, Motivation, Pamela, Petal, Piedmont, Prima, Purist, Sabu, Salem, Shas, Valon, Vanguard, Vox, Whirlybird, Young People's Records.)

Pacific Record Dist.

2663 West Pico Blvd.
Robert Field—DU 1-2034
(Dore, Ero, Golden Wing, Jaf, Laurie, Legrand, Monogram, Rust, Shelley, Shepherd, Soma, RSVP, Gregmork, Titan, Unical, Bamboo, Rodiant, Audicon.)

Pep Record Sales Inc.

2958 West Pico Blvd.
Ron Ricklin—RE 5-1297/RE 1-4146
(Colpix, Epic, 49th State, K&H, Tahiti, Colonial, Sims, Chart, Canadian American, Alon, Arhoolie, Caedmon, Charter, Okeh, Delmark, Dyer Bennett, Eterna, Exper-Anon, Folk Legacy, LMI, Lyrichord, Midnight, Motivation, Pan, Roulette, Shasta, Sun-glow, Tiara, Tahiti, Testament, 20th C.F., Vagabond, Vanguard, Vox.)

Record Mdse.

2580 West Pico Blvd.
Sid Talmadge—DU 5-9161
(Kapp, Vee Jay, Jamie-Guyden, GNP, Crescendo, Sun, Dooto, Standard, Colonial, Scepter, Wand, Old Town, Amy, Molo, 20th Fox, Coed, Congress, A&M, Crusader, Cameo, Parkway, Wyncoote, Hilltop, Diamond, Hull.)

RCA Victor Dist. Corp.

6051 Telegraph Road
D. G. Pierce—RA 3-6661
(RCA Victor, RCA Camden, RCA Victrola, RCA Groove, RCA Foreign Labels: Also tapes.)

Record Sales Co.

2818 West Pico Blvd.
Al Sherman—RE 1-9474
(Stereo Fidelity, Mainstream, Somerset, Tempo, Auto Spectrum, Ascot.)

(Continued on next page)

What put us up here.....

BETA
DISTRIBUTORS

TOP PROMOTION
TOP SERVICE
TOP SALES

equals

TOP HITS!!!

Johnny Halonka

BETA RECORD DISTRIBUTORS

599 10th Avenue (Phone CH 4-3744) New York, N. Y.

many thanks to all my friends

AL MARTINO



LATEST ALBUM



T-2362



RECORD DISTRIBUTORS

AND THE LINES THEY HANDLE

LOS ANGELES (continued)

Repeat Record Dist.
5782 East 2nd St.
(Long Beach)
John Mellen—GE 9-7785
(Lift, Repeat.)

Sun State Music Dist. Inc.
2673 West Pico Blvd.
Albert V. Lotouska—DU 3-4137
(Amadeo, Dr. Bansk, Cal-Bar, Calliope, Challenge, Cricket, Dulcet, Fidelity Sound, Recording Fleetwood, Haydn Society, Instant Learning, Mark 56, Montclare, Mummil, Off 8'way, Overland, Pipeline, Strand, Surprise, Universe, Voliant, Warner Bros.)

Sutton Record Sales Inc.
1023 North Lo Brea Ave.
Robert E. Blythe—656-8760
(Sutton, Tiora, Camay, Strand.)

Western Record Dist.
2962 West Pico Blvd.
Robert Sorenson—RE 2-8165
(Mercury, Wing, Philips, Fontana, Smosh, Limelight. Also: Mercury Home Entertainment Products, Phonographs and Tape Recorders.)

OAKLAND—(415)

Chattan Dist. Co.
2517 San Pablo Avenue
Robert M. Chatton—444-5677
(Argo, Atlantic, Cameo, Checker, Chess, DCP, Dore, Era, Kapp, Legrand, Living Language, Parkway, Specialty, 20th Century Fox.)

Dat Record Dist. of Northern Calif.
2517 San Pablo Avenue
Robert M. Chatton—444-5678
(Dot, Hamilton.)

SAN FRANCISCO—(415)

Acme Sales Co.
270 6th St.
Olen Harrison—UN 3-3674
(Alegre, All Saints, Arhoolie, Ball, Class, Disco Columbia, Eterna, Experience, Fortune, Fuentes, Glad Hump, Lyrrichard, Meritis, Maype, Proverb, Remo, Southland, Scope, Velvet, Listen and Learn, Apostic, Atlas, Baytone, Bego, Big Bee, Booker, 11 Bros. Celinda, C.J., Colt, Ea Jay, Enrica, Golden Bridge, Gwenn, 111Q, 111 Tone, Jayo, La Val, Lumbitone, Magnifico, Morvella, Mayhams, Mel, Message, Miami, Olmo, Poth, Roecox, Revis, Sol, Sonja, S.S.J., Teek, Trac, Unicorn, X Tone, West Coast.)

Colectran
33 Gough St.
M. B. Kirk—MA 1-3400
(RCA Victor, Camden, Hilltop, Pickwick.)

H. R. Basford Co.
235 15th St.
Patrik Butler—MA 1-8545
(Columbia)

Capitol Record Dist. Corp.
475 Borneveld Avenue
Charles Braunhauer—VA 6-5454
(Capitol, Angel.)

C & C and Boy Dist. Co.
70 Apparel Way
Gene Becker—MI 7-3806
(Mercury, Warner Bros., Oelfi, Prestige, Good Time Jazz, Music Minus One, Voliant, Liberty, Dolton, Imperial, Conodian American, Folkways, Disneyland, Dooto, Fiesta, World Pacific.)

Decca Dist. Co.
66 Dorman Ave.
Vem Cupples—VA 4-0161
(Decca, Coral, Brunswick, Vocation, Listen & Learn.)

Eric Dist. Co.
1251 Falsam St.
Bob Ellis—HE 1-8154
(ABC Par., Atco, Comond, Westminster, United Artists, Impulse, Musicor, Prestige, Apt, Tangerine, Music Guild, Grand Award.)

Field Music Sales Inc.
1480 Howard St.
Robert D. W. Chinn—UN 3-2258
(Vee Jay, Dimension, Lourie, Dort, Admirol, Amy, Aurora, Bell, Big Hill, Blue Rock, Bluestown, Champion, Colonial, Constellation, Discuba, Dynovoice, Dunhill, Eco, Falcon, Fame, Golden Crest, Gold Wax, Gordy, Interphon, Kent, Mala, Maxx, Melody, Mike, Musart, Nola, Oldies 45, Orfeon, Peerless, Standard, Simon Says, Sphere, Sound, Tollie, Village Gate, V.I.P., Vivid, Windsor.)

Mainland Dist. Co.
1251 Folsom
Earl Woolf
(Verve, MGM, Colpix, Roulette, Swan, Folkways, Honno-Barbara, Mainstream, Sun, Time.)

Melody Sales Co.
444 6th St.
Al Bromy—MA 1-8740
(Epic, Fantasy, Reprise, Caedmon, Okeh, Elektra, Lomo, Modern, Nonesuch, Warner Bros.)

A. H. Meyer Co.
33 Gough
James O. Castello—MA 1-3400
(RCA Victor, Camden, Groove, Victrola, Vintage.)

Stone Dist. Co.
1175 Howard St.
Jack R. Juhozz—MA 1-1837
(London, Richmond, Telfunken, Audio Fidelity, Dauntless, Original Sound, IPG, Monument, Il'oiseau, Lyric, Amadeo, Period, Harmonia, Mundi.)
Ultraphone, Vega, Virtuouse, Vox, Vulcan, Windine
Ball, World Lib. of Sacred Music, Oak Publications.)

COLORADO

DENVER—(303)

Boyd Dist. Co. Inc.
1661 West 3rd Avenue
Joe Corovona—222-7701
(Capitol, Angel, Capitol of the World)

Craig Carp.
4959 Colorado Blvd.
Bob Murphy—399-0434
(Epic, Okeh)

Crown Dist.
600 15th St.
Morey Samuelson—KE 4-9301
(Westminster, Folkways, Tom Lehrer, Monitor, Fiesta, Caedmon, Minus-One, Tradition, Colpix, Hi-Fi, Elektra, Nonesuch, Restview, Prima, Artia, Parliament, MK, Peter Pan.)

Davis Sales Co.
3825 Newport
Bill Davis—355-1638
(Audio Fidelity, Dot, Duke, Everest, Hamilton, Scepter, Wand, Atco, Atlantic, Dolton, Fox, Kent, Liberty, London, Monument, Stereodiddies, Telefunken, Time, Hanno-Barbara, Imperial, Laurie, Red Bird, Richmond, Verve.)

Denver Record Dist.
3825 Newport
Bill Davis—355-1638
(Amy, Challenge, Congress, Happy Time, Instant Language, Mala, Mercury, Original Sound, Reprise, Smash, Voliant, Warner Bros.)

Walter Slagle & Co.
725 South Broadway
Grace Barger—777-2645-2646
(ABC Paramount, Golden Crest, A&M, Grand Award, Kopp, MGM, United Artists, Co-Ed, Musicor, Comond, Deutsche Grammophon, Fraternity, Spt, Impulse, Tangerine, Westminster, Music Guild, Big Top, Caedmon, Elektra, Hi Fidelity, Metro, Music Minus One, Nonesuch.)

Word Terry & Co.
70 Rio Grande Blvd.
P.O. Box 869
Robert K. Davis—266-3181
(RCA, Camden, Disneyland, Hilltop, Victrola, Pickwick.)

CONNECTICUT

EAST HARTFORD—(203)

Allied Record Dist.
360 Tolland St.
Richard Godlewski, Frank Sutter
289-7431
(ABC Paramount, Blue Note, Command, Era, Fleetwood, Grand Award, Hob, Impulse, Joy, Prestige, Scepter, Select, Sun, Verve, Wand, Westminster, Mr. Maestro, Music Guild, Apt, Tangerine, Dunhill, Mace, Philles, Pricewise, Status)

Associated Record Dist
360 Tolland St.
Frank P. Kelley—289-7431
(Audio Fidelity, Bert & L. Cabot, Caedmon, Canadian American, Challenge, Dana, Dauntless, Deutsche Grammophon, Dictation, Disc, Fiesta, Golden, Greco-phone, Hi Fi, Life, Music Minus One, Simon-Says, Somerset, Stereodiddies, Warner Bros., Josie, Jubilee, Reprise, Scotch Recording Tape, Audia Spectrum, Monitor, Request, Hanna-Borbera.)

Capitol Records Dist. Co.
207 Pitkin St.
Mervin Amalis—BU 9-0217
(Capitol, Angel)

Columbia Record Dist., Inc.
100 Constitution Plaza
Stephen Capone—522-7151
(Columbia, Also Masterwork Phonographs, Radios and Tape Recorders)

Eastern Record Dist. Inc.
360 Tolland St.
Dick Godlewski—289-7431
(Droll, Yankees, Epic, Kopp, Living Language, MGM, Muza, Okeh, Swan, Tom Lehrer, Vanguard, Audio Spectrum, Jay Jay, Metro, Motivation, Valiant)

Keystone Record Dist. Inc.
11 Word St.
Mickey Cassello—289-0223
(Laurie, Rust, Monument, King, World Artists, B.T. Puppy, Crown, American Arts, Suttum, Big Hill, Blast, Cornivol, Champion, Cheer, Cheltenham, Chattahoochee, Colonial, Corsican, Dala, Delfi, Disc, Donna, Dunes, Duo-Disc, Fabor, Fame, Folkarts, Folkways, General American, Hickory, Kent, Legrand, Modern, Providence, Sims, Sue, Tollie, Wyncote)

Seaboard Dist. Inc.
275 Park Avenue
Morv Ginsberg—289-9361
(Argo, Atco, Atlantic, Checker, Chess, Diamond, Dyneyland, Dolton, Dot, Elektra, Imperial, Liberty, Mercury, Philips, Roulette, Starday, Vee-Jay, Vista, Amy, Crecendo, DCP, End, Hamilton, Moonglow, Nonesuch, Old Town, Original Sound, Tico, Tower, Volt, Wing)

Trinity Record Dist.
477 Park Avenue
Ed Dinallo—289-4349/4624
(Alector, A&M, Cameo, Colonial, Constellation, Conversaphone, Copley, Cumberland, Duke, Everest, Excellence, Fantasy, Fontana, Galaxy, Gordy, Gospel, Jamie, Motown, Musicor, Nashboro, Nina, Parkway, Pacific Jazz, Peacock, Red Bird, Regent, Star, Savoy, Sharp, Smash, Specialty, Spoken Arts, Standard, Tamla, Tradition, 20th Century Fox, United Artists, World Pacific, Wyncote, Ascot, Blue Cat, Blue Rock, Charger, Colpix, Golden World, JJC, Rampart, Ric, Word, King, Federal, Deluxe)

DISTRICT OF COLUMBIA

WASHINGTON—(202)

Schwartz Bras. Inc.
2146 245th Place N.E.
James Schwartz—526-4500
(A&M, Musicor, Pickick 33, Argo, Atlantic, Audio Fidelity, Blue Note, Checker, Chess, Contemporary, Deutsche, Grammophon, Elektra, Good Time Jazz, Gordy, Jubilee, Kapp, Liberty, Monument, Motown, Reprise, Roulette, Somerset, Stereo Fidelity, Starday, Sue, Tamlo, Time, United Artists, Vanguard, Vee Jay, Verve, Warner Bros.)

FLORIDA

HIALEAH—(305)

Goldstote Record Dist. Inc.
4500 N.W. 36th Avenue
Allan Walk—635-2428
(Somerset, Stereo Fidelity, Coronet, Spinorama, Secco, Jubilee, Crown, Mt. Vernon, Buckingham, Diplomat, Strand, Chesterfield, Tiki, Amazon, Invicta, Dynamite, Petal, Span, Prann, Gambit, Teena, Sony, Zebra)

Tone Dist.
495 N.E. 10th Court
Henry Stone, Milt Oshine—TU 7-7546
(Apt, Impulse, Tangerine, Music Guild, Westminster, ABC, Atlantic, Audio Fidelity, Argo, Chess, Checker, Constellation, Cameo, Duke, Era, Fabor, Jamie, Jubilee, Kent, Laurie, London Group, Monument, Motown, Tamlo, Swan, Sue, Parkway, Old Town, Scepter, Reprise, Sun, United Artists, Vee Jay, Wand, Westminster, Warner Bros., Time)

(Continued on next page)

FOR COMPLETE COVERAGE
OF THE NORTH EAST
IT'S THE **BIG 3**

DELTA
RECORDS OF BUFFALO,
INC.
890 Main Street
Buffalo, N.Y.
(716) 884-0500

DELTA
RECORD DIST., INC.
1260 Broadway
Albany 4, N.Y.
(518) HO 2-6564

KEYSTONE
RECORD DIST., INC.
11 Ward St.
East Hartford, Conn.
(203) 289-0223

LABELS WE HANDLE INCLUDE

A & M	CALLA	DICTATION DISCS	GOAL	MAGNUM	SOUL
ADMIRAL	CANJO	DIMENSION	GOLDEN WORLD	MALA	SPECIALTY
AM CAN	CAMEO	DISC	GORDY	MAR V LUS	STARMAKER
ADVENTURE	CANADIAN AMERICAN	DORE	GOSPEL	MAXX	SUE
ALMONT	CHALLENGE	DUKE	HILLTOP	MODERN	SURE SHOT
AMERICAN ARTISTS	CHAMPION	DUO DISC	HICKORY	MOHAWK	SWAN
AMY	CHATTAAHOOCHEE	DONNA	HOB	MONITOR	SWING
ARAVEL	CLOCK	DUNES	JOSIE	MONUMENT	SYMBOL
ARTIA	CHENE	ERA	JUBILEE	MOTOWN	TAMLA
AUDICON	COED	EASTERN	JOY	MUSICOR	TIME
AUTUMN	COLONIAL	EXCELLO	K F M	MUTUAL	TOLLIE
B. T. PUPPY	COLPIX	FABOR	KING	NASCO	TOWER
BACKBEAT	CONGRESS	FEDERAL	LAURIE	NASHBORD	TRADITION
BELL	CORSICAN	FOLK ART	LEGAND	NORK	U. S. A.
BETHEHEM	CRACKER/JACK	FOLKWAYS	LEGEND	OLDTOWN	VILLAGE GATE
BIG HILL	CROWN	GNP CRESCENDO	MACE	ONEDERFUL	VIP
BLUE NOTE	D. TOWN	GARRETT	MAINSTREAM	ORIGINAL SOUND	WAND
BLUE ROCK	DANA	GATEWAY		PARKWAY	WORKSHOP JAZZ
BRIO	DEL FI				WORLD ARTISTS
BROADWAY	DERBY				WYNCOTE

LAREDY has completed 9
successful years because
of REPUTATION, SERVICE
PROMOTION & SALES.

LAREDY
RECORD DIST., CORP.
46 Green Street
Newark, New Jersey
(201) MA 3-5984



PLACE YOUR RECORDS
IN THE HANDS OF EXPERTS
in
NEW YORK
ALBANY

HARRY N. APOSTOLERIS

ALPHA
DISTRIBUTING CORP.

20 West End Avenue
New York, N.Y.
Phone (212) 245-7933

RECORD DISTRIBUTORS

AND THE LINES THEY HANDLE

FLORIDA (continued)

MIAMI—(305)

Brooke Dist. Co.
380 N.E. 67th St.
Manny Brookmire—PI 1-9752
(London & Richmond)

Campus Records Dist. Inc.
6751 N. W. 37th Ct.
Jae Stancione 691-3140
(Epic, Okeh, Pickwick, Ric-Tic, Wingate, Mar-V-Lus, One-Der-Ful, Four Brothers)

Capitol Records Dist. Co.
80 E. 10th Ave.
John Griffith—887-4319
(Capitol, Angel)

Carib Corp.
P.O. Box 748
Patricia V. Jacobs—885-3738
(Carib, Island Artists, Famo, Westindy)

Columbia Record Dist.
3641 N.W. 67th St.
Bob Beasley—Ox 6-0033
(Columbia, Harmony)

Dot Records Dist. Inc.
2335 N.W. 8th Ave.
Pally Reese—633-0643
(Dot, Hamilton)

Florida Record Dist. Inc.
8160 N.W. 36th Ave.
Charles Peters, Marty Marks
696-4951
(Four Corners, MGM, Verve, Time, Disneyland, Fiesta, Tico, Vista, Mainstream, Banner, Command, Grand Award, Crescendo, Congress, Hanna-Barbera, Motown, Musicor, Tower, Tram, Living Language, Metro, Deutsche Grammophon)

Goldstate Record Dist.
4500 N.W. 36th Ave.
Allan Walk, Marvin Lieber
635-2428
(Somerset, Stereo, Fidelity, Forum, Dyna Disc, Major label cut-outs, Oldie-Goldie Hit 45's, 5 pack grab-bag 45's)

Music Sales of Florida, Inc.
2450 N.W. 77th Terrace
Don Smith—691-0340
(After Hours, Aura, Blue Note, Coliseum, Chart, Fantasy, Folk Art, Fax, Garrett, Heartwarming, Hickory, Laugh Time, London, Mr. Maestro, Pacific-Jazz, Peerless, Surprise, Sacred, Summit, Stereod ditties, Soma, Telefunken, World Pacific, Word)

Sea Coast Appliance Dist. Inc.
3575 N.W. 60th St.
J. W. Shockey—NE 5-0951
(RCA Victor, Camden, Groove, Soria, RCA International Labels)

MIAMI SPRINGS

Florida Music Sales, Inc.
5411 N.W. 36th St.
Steve Braokmire—887-6551
(Mercury, Philips, Smash, Limelight, Fontana, Wing, Cumberland, Blue Rock)

RCA Victor Dist. Co.
1500 Marietta Blvd. N.W.
James V. C. Horter—355-2960
(RCA Victor, RCA Camden, Victrola, Vintage, Groove, Fidelity, Lyric Racks)

Southland Records Dist. Co.
1235 Techwood Drive, N.W.
Gwen Kesler—873-2081
(ABC, Argo, Atlantic, Bluenote, Checker, Chess, Constellation, Dot, Duke, Gordy, Hi, Imperial, Impulse, Kent, Monument, Red Bird, Stax, Tamla, Vanguard, Veejay, World Artists, Apt, Tangerine, Westminster, Music Guild, Audio Fidelity, DCP, Dial, Hamilton, Living Language, Mainstream, MGM, Modern, Nashboro, Parrott, Peacock, Phyllis, Scepter, Skylite, Volt, Wand, King, Federal, Deluxe.)

HAWAII

HONOLULU

Craig Corporation
345 Kamani St.
John H. Heiner—586771
(Columbia, Epic, Okeh)

Eric of Hawaii
607 Coral St.
Irv Pinensky—511-657
(Warners-Reprise, UA, ABC, MGM, Verve, Apt, Impulse, Tangerine, Music Guild, Vee-Jay)

Microphone Music Co.
605 Coral St.
Ken Kaizawa—502188
(Atlantic, Atco, Argo, Chess, Checker, Cameo, Can Amer, Dot, Disneyland, Jamie, Jubilee, Kapp, Living Language, Monument, Roulette, Scepter, Parkway, Swan, Wand, Musicapex, Challenge, Congress, Dooto, Golden, Regina, Valiant, Four Corners, Red Bird, Blue Cat, Tower)

Music Craft Dist. of Hawaii Ltd.
636 Queen St. (P.O. Box 2839)
Walter Kurakawa—501-223
(Amy, Blue Note, Command, Coed, Colpix, Dimension, Fax, Grand Award, Hickory, Laurie, Monitor, Starday, Stereoditties, 20th Century Fox, Tradewinds, Vanguard, Charger, Circa, Command, Cordak, Congress, Prix, King, Legrand, Original Sound, Prestige, Storytime)

Nylen Bros. & Co. Ltd.
820 S. Beretania St.
Ed Nielsen—581-171
(A&M, Audio Fidelity, Audio Spectrum, Aura, Concert-Disc, Contemporary, Caedmon, Dolton, Era, Everest, Fantasy, Gordy, Imperial, Liberty, Makaha, Minit, Motown, Music Minus One, Magnet, Pacific Jazz, Tamla, Word, World Artists, World Pacific, Bep, Clover)

Polynesian Dist. Ltd.
820 S. Beretania
George Chun—581-171
(Liberty, Imperial, Contemporary, Audio Fidelity, World Pacific, Era, Dore, Motown, World Artists, Everest, Double L)

Radio TV Corp. Ltd.
432 Keawe St.
Arthur W. Kay—502-901/564-416
(RCA Victor, Camden, Groove, London, London American, Mercury, Wing, Smash, Fontana, Limelight)
(Continued on next page)

GEORGIA

ATLANTA—(404)

Capitol Records Dist. Corp.
2075 Manrae Dr. N.E.
Tom Beckwith—874-4433
(Angel Records, Capitol, Capitol of the World, Promenade)

Comstock Dist. Co.
1323 Spring St. N.W.
Don Comstock—876-0321
(Columbia, Epic, Okeh.)

Criteria Record Dist.
524 Plasters Ave. N.E.
Jack Lynn—874-2781
(Sounds of Atlanta, World Wide)

Decca Dist. Corp.
156 Alexander St.
Ed Russell—Ja 4-8428
(Decca, Coral, Brunswick, London, Richmond, Telefunken, Listen & Learn, Caedmon)

Dixie Records Dist. Co.
1235 Techwood Drive N.W.
John Towles—Tr 3-2081
(Atco, Cameo-Parkway, Contemporary, Canadian American, Del Fi, Disneyland, Dolton, Fabor, Hilltop, Jamie, Jubilee, Kapp, Liberty, Musicor, Old Town, Original Sound, Starday, Swan, UA, Verve, Ascot, B.T. Puppy, Brooklyn, Congress, Four Corners, Good-time Jazz, Nashville, Prestige, Vista)

Georgia Record Distributors
13 Luckie Street, N.W.
Steve Brookmire 523-1961
(Blue Rock, Cumberland, Fontana, Limelight, Mercury, Philips, Smash, Wing)

Godwin Dist. Co.
655 Ethel St.
Art Godwin—876-5719
(A & M, Amy, Almo, Aura, Autumn, Bell, Challenge, Coed, Colpix, Command, Conversaphone, Dimension, Dooto, Elektra, End, Era, Golden, Gordy, Grand-Award, Gospel, Hickory, Hi Fi, La Louisianne, Laurie, Lee, Loma, Mala, Maxx, Motown, Melody, Kenwood, Nonesuch, Project, Pacific Jazz, Rampart, Reprise, Rust, Roost, Rotate, Roulette, Regent, Savoy, Sharp, Soul, Squire, Tico, Tower, T C F, 20th Century Fox, V I P, Valiant, Village Gate, Warner Brothers)

"In Maryland, Washington D.C., Virginia, General Distributors does it best".

"I know why because they love what they're doing".

"Yeah, they love records and music and Manufacturers and Disk Jockeys and..."



General  **DISTRIBUTING CO., INC.**
HENRY NATHANSON, PRES.
2329 PENNSYLVANIA AVE. BALTIMORE 17, MD. NO. 9-6411

IN NEW YORK AND NEW JERSEY

You will get the strong sales coverage and merchandising know-how of our professional staff

ALL-STATE

MEL KOENIG Pres. • SHERMAN KOENIG Treas. • IRWIN FINK Vice Pres. • FRANK CAMA Sales Mgr.

Promotional Staff: Gene Ammond & Ray Free

NINE HARD-HITTING HUNGRY SALESMEN

ALL STATE, N.J., INC.

321 SHERMAN AVE.
NEWARK, N.J.
201-242-6500

ALL STATE RECORDS, INC.

619 WEST 56th ST.
NEW YORK, N.Y.
212-WO-4-9350



bobby vinton



record promotion:
pete bennett

direction:
allen klein

time & life building
new york, n.y.

Best Wishes
**TO CASH BOX ON YOUR
 23rd ANNIVERSARY**

from

JAMES H. MARTIN

• INCORPORATED •

**LONDON—DOT—SOMERSET—STEREO FIDELITY
 MONUMENT—HILLTOP—HAMILTON—
 VANGUARD—PICKWICK 33**

• DISTRIBUTORS •

2419 SO. MICHIGAN AVE., CHICAGO, ILL.

Phone: Victory 2-4440

**RECORD
 DISTRIBUTORS**

and the lines they handle

ILLINOIS

CHICAGO—(312)

Allstate Record Dist. Co.
 1450 S. Michigan Avenue
 Paul J. Glass—939-3675

(Age, Atlantic, Blue Note, Checker, Chess, Diamond, Dyno, Everest, Fabor, Gordy, Herald, Jamie, Montel, Old Tawn, Phyllis, Riviera, Roulette, Sar, Sims, Smash, Specialty, Starday, Stax, Sue, Symbol, 20th Fox, USA, Ara, Barbara, Barry, Blue Cat, Blue Tone, Canjo, Charger, Charter, Cheltenham, Chief, Class, Clock, Crackerjack, Dade, DeJac, Derby, Destination, Dial, Dooto, Duo Disc, Cumberland, Eastern, Ember, End, Focus, Fantana, Gee, Glover, Gane, Guyden, Heide, Hi Fu, Hollywood, J&S, Jewel, Joy, Kenwood, Landa, Lesage, Life, Lufine, Magnum, Melody, Motown, Music City, Nashville, Paula, Pharos, Phi Dan, Pip, Project, Red Bird, Roost, Rosemart, Select, Soft, Squire, Teardrop, Tico, Tip, Tuff, Vivid, Volt, Workshop Jazz.)

Apollo Dist. Corp.
 1410 S. Michigan Ave.
 Bert Loab—427-5663

(Riverside, Battle, Washington, Offbeat, Jazzland, Wonderland, Montilla, Fleetwood, Briar, Request, Mr. Maestro, Simon Sez, Joe Davis, Alegre, Seco, Gema, Listen and Learn, Famous, Bacon, Original Sound)

K. O. Asher Inc.
 7818 S. Story Island Ave.
 K. O. Asher—RE 1-1741

(AH, Alestar, Amadeo, Apon, Arhoolie, Asco, B&F, Budapest, Baroque, Bartok, Boyes, Broadside, Caedmon, Cambridge, Cantate, Cavalier, Detra, Classic Editions, Colonial, Connoisseur, Conversaphone, Folk-Legacy, Falk-Lyric, Golden Crest, Harmonia Mundi, Harvest, Helios, Icon, Jazz Cool, Jazz Crusade, La Voix De L'Auteur, Lenco, Lyricard, Monitor, Motivation, Music Library, Music Minus One, Nobility, Odeon, Rainbow, Renaissance, Scala, Scandinavian, Science Material, Shakespeare, Siena, Sonart, SPA, Spoken Arts, Spoken Words, Standard, Stradivari, Tap, Testament, Tradition, UTC, Unesco, Vocab, Audio Precision, Bel Canto, Blues Classic, Bernard, Boston, Britam, Boitesa Music, Chesapeake, Composers, Contemporary, Danish Odson, Debut, Desto, Disc, Distinguished, Dyer-Bennet, Ebony, Efon, Electrola, Elektra, ENS, Enrichment, Euphonic, Evergreen, Experience, Anonymous, Folk-Promotions, Folkways, Fortune, Friends of 4 Hand Music, GHB, Gregorian Inst., Harmony Music, Haydn Society, Happy Jazz, Historical Jazz, Hup, Jazzologie, Musica Saera, Nina, Nonesuch, Narsemen, Old Time, Orient, Origin Jazz, Orfeo-Sonic, Olympus, Ovetone, Pathe, Pathway, Period, Philharmonic, Phillips Ent'l, Piedmont, Playhouse, Pinnacle, Portent, Pro Musica, Proscenium, Qual-Music, Spire, Spivy, Takoma, Theatre Recording Soc, Turnabout)

Capitol Records Dist. Corp.
 1326 So. Michigan
 George Geuken—HA 7-3500
 (Capitol.)

Columbia Record Dist. Co.
 2240 N. Milwaukee Avenue
 Norm Ziegler—HU 6-4700

(Columbia, Harmony. (Also: Amfile Carrying Cases, Columbia Tapes, Masterworks Phonographs, Radios and Tape Recorders.)

Consolidated Record Distributors
 1400 S. Michigan Ave.
 Paul Glass

(Mercury, Philips, Smash, Fontana, Wing, Limelight, Cumberland.)

Decca Dist. Co.
 2441 S. Michigan
 A. Weiner—225-5800

(Decca, Brunswick, Vocalion, Listen & Learn, Contemporary.)

Garmisa Dist. Co.
 1303 S. Michigan Ave.
 Bobby Garmisa—922-7455

(ABC, Apt, Music Guild, Command, Impulse, Musicor, Ric, Tangerine, UA, Westminster, World Artists, Dunhill, Original Sound, Jax, Regina, JJC, Contact, Granet, DCP, Ascot, Veep, King, Federal, Deluxe.)

Liberty Record Dist. of Ill.
 1329 S. Michigan Ave.
 Jack Wajer—939-7194

(Liberty, Dolton, Imperial, Minit.)

James H. Martin Inc.
 2419 S. Michigan Ave.
 James H. Martin—VI 2-4440

(London, Dot, Vanguard, Somerset, Stereo Fidelity, Richmond, Monument.)

M & S Dist. Co.
 1700 S. Michigan Ave.
 Mill Saltstone—WE 9-7571

(Amy, Mala, Argo, Audio Fidelity, Cameo, Challenge, Caed, Congress, Dore, Era, Fraternity, K&H, Kapp, Laurie, Parkway, Reprise, Rust, Swan, Valiant, Vee Jay, Warner Bros., Bell, Dynovoice, Fame, Four Corners, Golden Wax, Gregmark, Loma, Monogram, Tallie, Tower, Premiere.)

Metro
 6112 So. Wabash
 Morrie Price
 MGM, Verve, DGG.)

Midwest Mercury
 1455 So. Michigan
 Marland A. Waak—922-7455
 (Mercury, Philips.)

Music Dist. Inc.
 2419 So. Michigan
 Jack Solinger—VI 2-4440

(Ava, Colpix, Dance Along, Bonanza, Delta, Dimension, Ford.)

RCA Victor Dist. Corp.
 5050 S. Kedzie Ave.
 Ralph Ergas—PR 8-3000

(RCA Victor, RCA Camden, RCA Victrola, RCA Groove, RCA Victor Tapes, RCA Camden Tapes, RCA Vintage Series.)

Record Dist.
 4135 W. Armitage Ave.
 A. Galgano—R. W. Lawrence
 Di 2-7060

(After Hours, Aristophone, Artia, Avon, Murray, Collector's Guild, Eurotone, Europa, Fax, Grecophon, Helios, Halifax, Laughtime, Liberty, Greek, MK, Maestro, Major, Earl Nightingale, Parliament, Riot, Songs of Faith, Supraphon, Surprise, Ruth Wallis, Zian, (bennybell), Arta, Arnold Palmer, Baronet, Camay, Cameo-Parkway, Coronet, Cricket, Crown, Craftsman, Design, Diplomat, Fiesta, Family, Forum, Gryphon, Guest Star, Grandisco, Happy Time, Kimberly, Mappet, Palace, Pleasant Peasant, Ridgemoor, Re-Car, Request, Seeco, Somerset, Spinorama, Strand, Summit Sound, Sutton, Tropical, Urania, Virgo, Wyn-cote, Needles: Jensen, Electro-Voice, Recoton Tapes, Scotch-American.)

(Continued on next page)

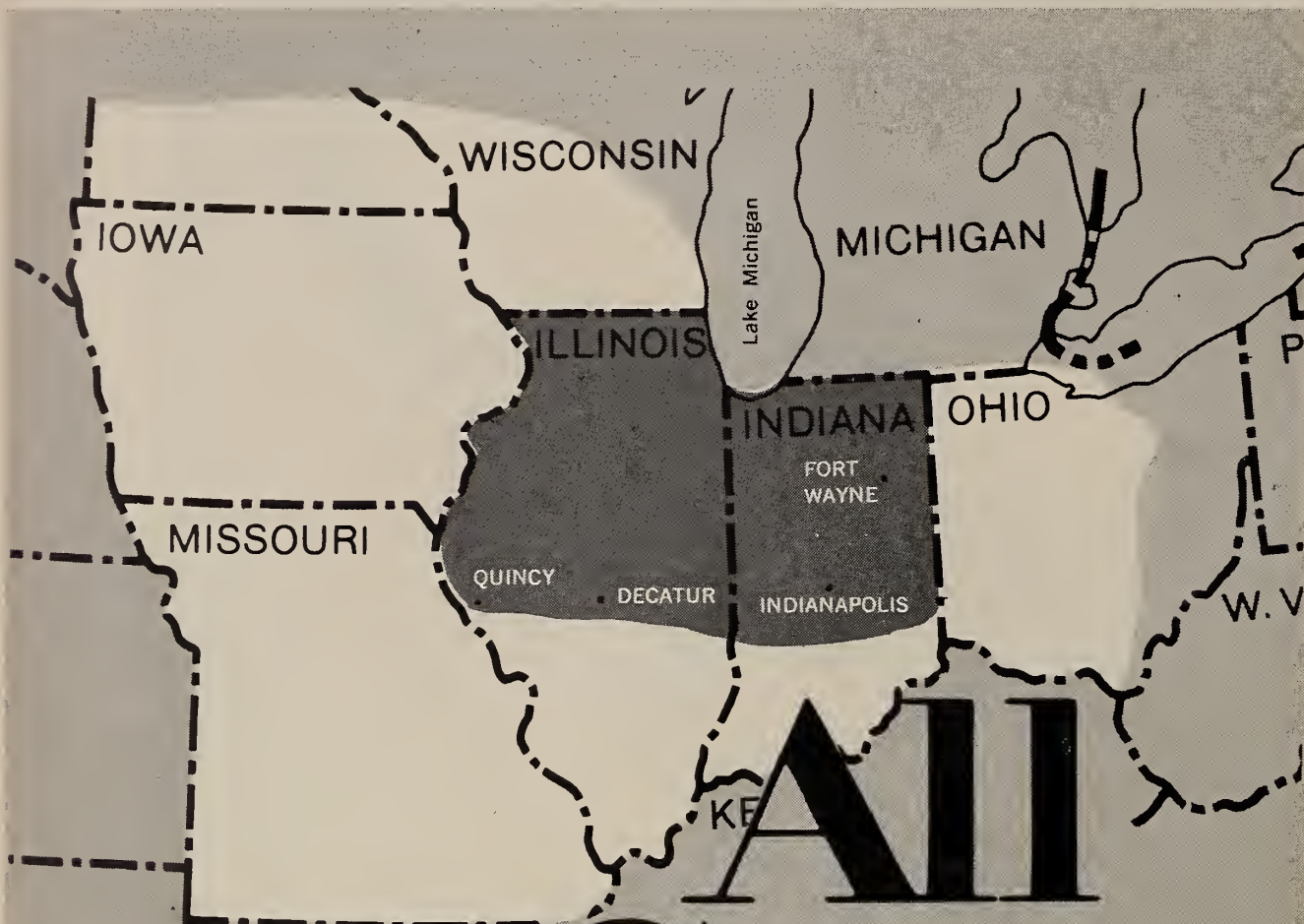

All

State

RECORD DISTRIBUTING CO.

1450 SOUTH MICHIGAN AVE., CHICAGO, ILL. 60605
 PHONE: (AREA CODE 312) 939-3675

Serves the Independent Manufacturer with
 Aggressive Promotion — Sales — Merchandising
 on

POP • R & B • C & W • SINGLES & LP's

LEE HOWARD • PAUL GLASS • HOWARD BEDNO & CY GOLD
 Sales Mgr. President Promotion



sam cooke

RCA VICTOR
The most trusted name in sound

record promotion:
pete bennett

allen klein & co., inc.
time & life building
new york, n.y.



**WE
DELIVER
FIRST**
in the
southern
market
**BIGGER SALES
BETTER PROMOTION**

**GODWIN
Record Distributors**

Atlanta, Georgia
655 Ethel St., N.W. (404) 876-5719

**OUR THANKS
TO THESE GREAT
MANUFACTURERS**

Atco - Atlantic - Vault
Volt - Stax - Focus
Elektra - Nonesuch
Duke - Peacock
Backbeat
Contemporary
Good Time Jazz
Philles - Specialty
Moonglow - Soma
Garrett - Golden Ring
Tally - Autumn
Hanna - Barbera
Triumph - Request

**MERIT
DISTRIBUTING CORP.**
2800 West Pico Blvd.
Los Angeles, Calif. 90006
Phone: REpublic 1-8791

Jack Lewerke, President
Bill Pieper, General Manager
Gene Simmons, Promotion
Ed Mosley, Promotion

In
**CONNECTICUT
WESTERN MASS.
ALBANY, NEW YORK
& VERMONT.**

**IT'S
TRINITY
RECORD DIST.**

FOR { you make em } HITS
{ we break em }

Call "Big Ed" Dinallo
or Jack Manus

477 Park Ave.
East Hartford, Conn.

203-289-4349
203-289-4624
203-289-4640
203-289-5339

RECORD DISTRIBUTORS

and the lines they handle

CHICAGO (CONT.)
Ron-Jac
1020 Lawrence Ave.
Jack Barthel—561-2100
(Lines not available at Press Time.)

Royal Disc. Dist.
1239 S. Michigan
Kent Beauchamp—939-2661
(BT Puppy, Dana, Dictation, Enterprise, Faro, Gate-
way, Goal, Josie, Jubilee, Most, Musictapes, Provi-
dence, Storytime, Amboy, Avin, Atco, Canadian-
American, Conduc, Contemporary, Delmork, D-Town,
Goodtime Jazz, Gross, Ideol, K-Arc, Lindo, LLP, "M"
Records, Mike, Mighty, Moonglow, Port, Rampart,
Steretapes, VIP.)

Seebro Dist. Co.
2019 So. Michigan
R. Siegal—842-8221
(Compose, Diplomot, Guest Star, Peter Pan, Rocking
Horse, Seebro Racks.)

Summit Dist. Inc.
1345 Diversay Parkway
Jack White & Seymour Greenspan
248-3621
(A&M, Almo, Aura, Chart, Chattahoochi, Constella-
tion, Crestview, Del-Fi, Disneyland, Donna, Elektra,
Epic, Fidelity Sound, Gorrett, Golden World, Hick-
ory, Nonesuch, Norman, Okeh, Pacific Jazz, Somo,
Stinson, Tally, Tradition, Vista, World Pacific,
Autumn, Delmor, Fantasy, Galoxy, Great, Longhorn,
Mainstream, Meric, Mobile Fidelity, Pon, Prism, Ric-
Tic, St. Lawrence, Southern Sound, Stereo-Oddities,
Train.)

United Record Dist. Inc.
1827 S. Michigan Ave.
Ernest Leaner—225-6605
(Bockbeat, Excello, Glad, Gospel, Hall, Kent, Mar-
V-Lus, One-Derful, Peacock, Savay, Scepter, Song-
bird, Sun, Tamlo, Wand, Arctic, Blue Rock, Colla,
Carnival, Celeste, Coun-tree, Duke, Ivanhoe, M-Pac,
Modern, Nashboro, Saul, Webcar.)

DES PLAINES
RCA Victor Dist. Corp.
424 East Howard St.
Ralph Ergas—(312) 827-0033
(RCA Victor, Camden, Victrola; Also: Victor and
Comden Tapes.)

INDIANA
FORT WAYNE—(219)
Tri-State Dist.
3434 Broadway
Cliff Ayers—744-5607
(Arrawak, ABS, All Star, Alto, Art, Arvee, Atlas,
Angelone, Avenue, Bandbox, Bartell, Baton, Bay Uke,
Bee, Beltone, Buddy, Bullseye, Chattahoochee, C&M,
Comous, Cimmorron, Contour, Crown, Cardinal, Clare,
Chroma, Desert, Delden, Dome, Commerce, Crescenda,
Ebbm Emerald, Empire, Era, Excella, Fax, Flick,
Flo-Jo, Ford, Golden World, Harvard, Hi-Fi, Hit,
Hudson, Injun, Jomie, Keane, Kenco, Lincoln, Lucky
Four, Marvello, Mecca, Miracle, Moon, Motif, Ma-
town, Nashboro, Neptune, Peacock, Prima, Petal,
Longhorn, Rae-Cox, Ram, Rebel, Robbins, Randolett,
RSVP, Hugo, Reno-Smiley, Sabre, Sage, Sims, Shee,
Spinix, Stordoy, Sand, Tamla, Tampa, Raylor, Vanity,
Vito, Variety, Wagner, Westport, Mayhams, Wedge.)

INDIANAPOLIS—(317)
Associated Dist.
210 S. Meridian St.
L. D. Jenks—Me 4-2591
(Audio Fidelity, Buena Vista, Colpix, Disneyland,
Groove, MGM, RCA Victor, RCA Camden, Somerset,
Starday, 20th Century Fox, Verve, Vox.)

John Robert Co.
1327 N. Capitol Ave.
Mary Lou Antibus—Me 7-4312/4313
(Crusader, DCP, Grand Award, Kapp, Laurie, Lime-
light, Wing, Mercury, Music Guild, Musicor, Original
Sound, Philips, Prestige, Status, Moodsville, Tru-
Sound, New Jazz, Bluesville, Regina, Reprise, Ric,
Teizer, UA, Vee-Jay, Warner Brothers, Westminster,
World Artists.)

IOWA
DES MOINES—(515)
Capitol Records Dist. Corp.
1118 Grand
H. A. Whitaker—243-3102
(Capitol, Angel.)

Mid-America Dist. Corp.
1630 Locust St. Box 299
Don Cooper—288-0182
(Mercury, Warner Bros., Dooto, Prestige, New Jazz,
Moodsville, Swingsville, Lively Arts, Tru Sound, Blue
Note, Philips, Smash, Era, Limelight, Mercury, Wing,
Childcraft, Storyteller, Fontana, Cumberland, Blue
Rock, Reprise.)

KANSAS
KANSAS CITY—(915)
RCA Victor Dist. Co.
Fairfax & Funston Rd.
Gil Karwaski—At 1-3075
(RCA Victor, RCA Comden, RCA Victrola, Interna-
tional Imports.)
(Continued on next page)

#1 IN THE SOUTHLAND

**SOUTHLAND RECORDS & DIXIE RECORDS
DISTRIBUTING CO. DISTRIBUTING CO.**

1235 TECHWOOD DR., ATLANTA, GA. (TR 3-2081)

OLYMPIA DISTRIBUTING CORP.
239 W. 18th Street New York, N.Y. 10011
Area Code: 212 989-7200

**12 YEARS IN NEW YORK CITY
AND NOW WE'RE IN OUR OWN 28,000 SQ. FT. BUILDING**

TWO PROMOTION MEN—TOPS IN PROMOTION
TEN SALESMEN—TOPS IN SALES
TOPS IN DISTRIBUTION
GOLDEN RECORDS—DISQUE D'OR—PRIMA MAGNAGROOVE
BIBLE STORIES—INSTANT LANGUAGE—DESIGN
GRAND PRIX—SOMERSET—HILLTOP
STADIUM—TIFTON—KELIT—REQUEST—SONART—BUDAPEST
B & F—AMBASSADOR—GUEST STAR—DIPLOMAT—GALIKO
SCIENCE AND EDUCATIONAL RECORDS
OUR COMPLETE LINE OF RECORD ACCESSORIES INCLUDES: NEEDLES,
BRASS RACKS, CARRYING CASES, ADAPTERS, CLEANING
CLOTHS, BRUSHES.

KAGS MUSIC CORPORATION

Time and Life Building
New York 19, N. Y.

1965

shake—sam cooke	it's got the whole world shakin'— sam cooke
cupid—johnny rivers	
wonderful world—herman's hermits	we remember sam cooke—lp— the supremes
bring it on home to me—the animals	
good times—the rolling stones	king curtis plays the hits made famous by sam cooke—lp
it's all over now—the rolling stones	
sugar dumpling—sam cooke	when a boy falls in love—sam cooke

1964

good times—sam cooke	you send me—four seasons
good news—sam cooke	bring it on home to me—shirley ellis
it's all over now—rolling stones	annie is back—little richard
it's all over now—valentinos	back to you—maxine brown

1963

another saturday night
frankie & johnnie
when a boy falls in love

bmi awards

good news	having a party
you send me	only sixteen
wonderful world	soothe me
chain gang	bring it on home to me
cupid	sad mood
everybody loves to cha cha	twisting the night away

j. w. alexander
president

direction:
allen klein
time and life building
new york, n. y.

SUDDEN SERVICE

MUSICAL SALES DIST. CO.

134 W. MT. ROYAL AVE.
BALTIMORE, MD. 21201
Phone: VERNON 7-5757

MILT BERESON
President

HOWARD "CHIC" SILVERS
Gen. Mgr. & Promotion

RECORD DISTRIBUTORS

and the lines they handle

KENTUCKY

LOUISVILLE—(606)

Foster Dist. Co.
409 W. Main St.
R. M. Foster—Ju 4-6207
(Capitol, Angel, Ambassador, Fidelitone Needles, Emerson Phonos, Phona Accessories.)

LOUISIANA

NEW ORLEANS—(504)

All South Dist. Corp.
630 Baronne
Henry Hildebrand—JA 5-6124
(Apt, Music Guild, ABC Paramaunt, A&M, Audio Fidelity, After Hours, Battle, Canadian American, Caedmon, Challenge, Colpix, Command, Congress, Crescendo, Cumberland, Diamond, Dictation, Dimension, Doota, Duke, Era, Fax, Fleetwood, Fantano, Grand Award, Impulse, Instant, Learning, Jamie, Jin, Jubilee, Kapp, La Louisianne, London Group, Mercury, Monument, Motown, Musicor, Okeh, Original Sound, Peacock, Philes, Reprise, Riverside, Scepter, Smash, Songs of Faith, Starday, Sue, Symbal, Tamla, Tangerine, Time, United Artists, Valiant, Vanguard, Wand, Warner Bras., Westminster, King, Federal Deluxe.)

Capitol Records Dist. Corp.
10232 Baronne St.
Elbert Allsup—524-6531
(Capitol, Angel)

Columbia Record Dist. Sales
John Hancock Bldg.
St. Charles Ave. & Lee Circle
Bill Shaler 524-4546
(Columbia, Epic.)

Decca Dist. Corp.
517 Canal St.
R. N. McCormick—JA 2-1746
(Decca, Coral, Brunswick, Vocation, London, Contemporary, Listen and Learn, Elektra)

Delta Record Dist. Co.
1023 Baronne St.
Ed Walker—525-7104
(Adventure Series, Alan, Archive, Argo, Atco, Atlantic, Aurora, Autumn, Blue Note, Buena Vista, Cameo, Charger, Checker, Chess, Constellation, Crusader, D.G.G., Dyna-Voice, Disneyland, Everest, Faber, Fantasy, 4-Bros., G.N.P., Galaxy, Glad Hamp, Gordy, Gospel, Hickory, Hi-Fi, Imperial, Jewel, Jasie, Jubilee, Kent, Kenwood, Laurie, Life, Living Language, Mainstream, Mar-V-Lus, Melody, Michelle/Montel, Minit, Maney, Moanglow, Old Town, One-Der-Ful, Paula, Phillips, Part, Prestige, Project, Rampart, Red Bird, Regina, Ric, Roast, Roulette, Rust, Savoy, Sims, Soma, Soul, Specialty, Sphere-Sound, Stax, Sue, Sun, Swan, 20th Century Fox, Tower, USA, Vee-Jay, Village-Gate, Valt, World Artist.)

Dat Dist. Corp.
605 Baronne St.
Jim Flattmann—522-3661
(Dat, Hamilton MGM, Metro, Verve)

Record Sales Inc.
744 St. Charles St.
Lloyd Linville—522-9956
(ABC Par, Ace, Battle, Chancellor, Chareo, Cub, Impulse, Metro, MGM, Offbeat, Parker, Riverside, Dytsnf, Time, Ultra Audio, United Artists, Vee Jay, Verve, Washington, Santa, Blast, Musicor, Park Avenue, Brent, Vesuvius)

Walther Bros. Co.
1722 Paydras St.
Milton H. Munch—Ja 2-7731
(RCA Victor, Liberty, Dalton, Disneyland, Vista)

SHREVEPORT—(318)

Stan's Record Service
728 Texas Ave.
Stan Lewis—422-7182
(A&M, ABC, Amy, Argo, Arlen, Atco, Atlantic, Backbeat, Blackwood, Caprice, Corlton, Challenge, Checker, Chess, Coed, Constellation, Crazy, Cajun, Crown, Dart, Del-Fi, Derby, Diamond, Dimension, Daata, Dare, Duke, Enjoy, End, Everest, Excella, Fabar, Fame, Fernwood, Fraternity, Goldband, Gordy, Gyden, Hall, Heritage, Hickory, Hi Fi, Imperial, Jamie, Jay Gee, Jewel, Jin, Jasie, Jay, Jubilee, Kapp, Kent, La Louisianne, Lanor, Laurie, Lecam, Legend, LK, Lyric, Mala, Marc, MGM, Minaret, Montel, Moon-glow, Motown, Musicor, Nashboro, Old Town, Original Sound, Parkway, Peacock, Philes, Phillips, Prestige, Princess, Reprise, Riverside, Ron, Roulette, Rust, Santo, Sar, Savoy, Scepter, Select, Shirley, Slims, Stacy, Starday, Stax, Sue, Sun, Swan, Symbal, Tamla, Tangerine, Teardrop, Tuff, 20th C-F, Typhoon, Ty Tex, UA, U.S.A., Vee Jay, Verve, Volt, World Artist, Abnak, Ace Alan, Alama, Apt, Ara, Ascot, Astra, Aura, Autumn, Blue Cat, B.T. Puppy, Bafuz, Buena Vista, Calla, Cameo, Carnival, Celeste, Charger, Circa, Circle, Coleman, Colpix, Congress, Crusader, D, D-Town, DCP, Del Mar, Delsey, Dial, Diplomat, Diplomacy, Disneyland, Duo-Disc, Eldo, Era, Fantasy, Flip, Frolic, Galaxy, Golden Crest, Golden World, Guest Star, Hanna-Barbera, Hermitage, Impala, Interphone, Jet Stream, Jet Star, Javial, KT, LG, Michele, Modern, Money, Murco, Mutual, N-Joy, One-Der-Ful, Paula, Peter Pan, RBE, Red Bird, Regina, Rik, Rod, Rotate, Sabra, Sage, Sand, Sama, Specialty, Spector, Swallow, Swinging, Tally, Tallie, Towne House, Tri-Fi, Vault, Vivid, Wax, World Pacific, Wand)

(Continued on next page)

JOHN O'BRIEN DIST., INC.

2830 West Vliet Street
Milwaukee, Wisconsin 53208
Phone: 344-3560

SALES

EXPERIENCED SALES FORCE!

PROMOTION

CONSTANT RADIO STATION CONTACT!

SERVICE

YOU GET IT HERE!

OUR BUSINESS IS RECORD DISTRIBUTION

OREGON
WASHINGTON
NORTHERN IDAHO
ALASKA

TOP SALES COVERAGE

HUFFINE DISTRIBUTING COMPANY

3131 Western Avenue
Seattle 1, Washington
206 ATwater 48633

For "Instants" in the West

PROMOTION
EXPLOITATION
PROFIT

BOB STERN

RON RICKLIN

PEP RECORD SALES Inc.

2958 W. PICO BLVD.
LOS ANGELES 6, CALIFORNIA

NEWEST—most progressive distributor
in NEW ORLEANS

PROMOTION ★ SALES ★ SERVICE

DELTA RECORD DISTRIBUTING CO., INC.

1023 BARONNE STREET
Ed Walker, Mgr.

Phone: 525-7104

NEW ORLEANS 12, LOUISIANA
Bob Spondlove, Pro. Mgr.



chad & jeremy

COLUMBIA 

record promotion:
pete bennett

direction:
allen klein

time & life building
new york, n.y.

COSNAT

19 years of
DEPENDABILITY
MERCHANDISING
SERVICE

And now a new division

CONSOLIDATED
ONE STOP OF NEW YORK
JU 2-2388

For All your record needs

The Originators of D.S.B.A. Program
The only program which offers you
5 months to pay for your purchases

COSNAT

DISTRIBUTING CORPORATION

A Division of The Cosnat Corporation
315 West 47th Street, New York 36, N.Y. PL 7-8140

In Detroit
The Fanfare is for . . .

music merchants, inc.

3731 Woodward Ave., Detroit 1, Mich. TE 2-0870

WE BREAK RECORDS

(sometimes just for fun)

WE MOVE PRODUCT

(the way it should be done)

Marvin M. Jacobs
Pres. and Gen. Mgr.

Joe Goleski
Sales Mgr.

Peter W. Hall
Promo Mgr.

IN PHILADELPHIA
Promotion In Motion Merchandising
Volume Sales

Universal

LEN RADCLIFF, Gen. Mgr.
record distributing corporation
919 N. Broad St. Philadelphia 23, Pa.
CEnter 2-3333

RECORD DISTRIBUTORS

and the lines they handle

MAINE

PORTLAND—(207)

Commercial Distrib.
212 Anderson Street
John Jannace—774-5362
(RCA Victor, Camden, Groove)

MARYLAND

BALTIMORE—(301)

Capitol Records Dist.
6910 Hartford Road
Bill Dawson—HI 4-6030
(Capitol, Angel)

Columbia Record Dist.
Aiken St. At Curtain Ave.
Geo. Deacon—Ho 7-9320
(Columbia, Epic)

D&H Dist. Corp.
2025 Worcester St.
Lester Pyle—727-5100
(RCA Victor, RCA Camden)

Decca Dist. Corp.
2921 Alexander Ave.
J. Edward Keelan—FO 7-0710
(Decca, Coral, Brunswick, Listen & Learn, Vocalion)

General Distributing Co.
2329 Pennsylvania Ave.
Harry Nathanson—669-6411
(Aura, Bethlehem, Gateway, King, One-Der-Ful, Sun, Word, World Artists, Dot, Diamond, Era, Excello, Gospel, Hamilton, Jamie, Ken, Modern, Nashbaro, Old Town, Prestige, Red Bird, Savoy, Scepter, Status, Vivid, Wand, World Pacific, Federal, Deluxe, Audio Fidelity, Karate.)

Marshall/Mangold Dist. Co.
4805 Nelson Ave.
Manny Goldberg—542-7214
(Calpix, Dimension, Amy/Mala, Hickory, Everest, Artia, Ambassador, Counterpoint, Disneyland, Fantasy, M.M.O., Parliament, Vista)

Marnel of Md. Inc.
5550 Newbury St.
Stan Hoffman—664-8500
(Epic, Okeh, Laurie, Swan, 20th C-F, DCP, Duke, Four Corners, Golden, Living Language, Nebs, Peacock, Gaspel, Backbeat, Cameo, Parkway, Rik, Congress, Veep, Clack, Classica, Camelot, Coed, Rust, Legrand, Caedman)

Jos. M. Zamboiski Co.
1101 De Soto Road
Herb Silverman—MI 4-2900
(ABC Paramount, Command, Dooto, Apt, Blue Rock, Meira, TCF, Mercury Wing, MGM, Mercury, London, Hi, Fontana, Impulse, Philips, Smash, Cumberland, Westminster, Grand Award, Richmond, Limelight, Tangerine, Music Guild)

MASSACHUSETTS

BOSTON—(617)

Bay State Record Dist. Corp.
1030 Tremont St.
Bob Levinson—427-5060/5061
(A&M, Almo, Audio Fidelity, Chess, Colonial, Dare, Elektra, Era, Faber, Flip, Fantasy, Galaxy, Guyden, Golden World, Nonesuch, Phillies, Regent, Scepter, Savory, Specialty, Standard, World Artists, Atlantic, Autumn, Bang, Caedmon, Blast, Clock, Distinguished, Duke, Enjay, Facus, General American, Hob, Jerden, Landa, Mace Music, Marvel, Minus One, Mutual, Nashville, Paula, Peacock, Pulse, Rampart, Ratate, Sims, Starday, Tax, Taurus, Wassell)

Decca Dist. Corp.
138 Ipswich St.
Allan M. Ross—CO 6-5110
(Decca, Coral, Brunswick, Vocalian, Listen & Learn)

Disc. Dist. Inc.
1136 Columbus
Jack Sager—445-3550
(Tama, Motown, Gordy, Melady, VIP, Sue, Crackerjack, Eastern, Broadway, One-Der-Ful, Sar, Derby, Dua Disc, Everlast, Fayette, Glad Hamp, Hull, Lawn, M-Pac, Marvelous, Mirimar, Soul, Swan, Symbol, Vest, Zen)

Dumont Record Dist. Corp.
1030-1040 Tremont St.
Div. I Donald E. Dumont—442-0800
(Argo, Atco, Bluebird, Cambridge, Can. Am., Cantata, Checker, Diamond, Epic, Jamie, Jubilee, Oldtown, Prestige, Roulette, Squire, West Coast, YJR, Bert S.I., B.T. Puppy, Command, Capley/Gael, End FM, Grand Award, Josie, Kenwood, Living Language, Moonglow, Murry Banks, Okeh, Original Sound, Pacific Jazz, Raast, Tica, Stinson, Vault, Valt, King, Federal, Deluxe, Bethlehem.)

Div II Herb Dale—427-2540
(Alectar, Avoca, Challenge, Dimension, Everest, Hi Fi, Red Bird, Stereodities, Tikva, Time, Banner, Blue Cat, Charter, Colpix, Europa, Eutone, Fiesta, Galden, Grecothane, Mainstream, Somerset, Regina, Stereo, Fidelity, Sure, Swinging, Tieger, Virgo, Vee Jay)

Music Suppliers, Inc.
75 No. Beacon St.
Harry Carter—AL 4-1780
(ABC Paramount, Cameo/Parkway, Kapp, Laurie, MGM, Reprise, Vanguard, Vax, Westminster, Deutsche Grammaphan, Verve, Warner Bras.)

Mutual Dist.
1241 Columbus Ave.
Frank Holland—442-5700
(Academy, Amy-Mala, Ascot, Crusader, Constellation, Joseph Csida Entpr., DCP, Dalton, Four Corners, Hilltap, Joy, Kent, Tawer, Disneyland, GNP, Hickory, Imperial, Liberty, London, London Group, Monument, Sound Stage 7, Musicar, 20th Century Fox, United Aura, Budapest, Drummond, Pacific Jazz)

(Continued on next page)

BEST WISHES TO CASH BOX

LENNIE GARMISA
GENE PONTILLO

BOBBY GARMISA
RON ALEXENBURG

Representing

ABC-PARAMOUNT
COMMAND
GRAND AWARD
WESTMINSTER
IMPULSE
TANGERINE
DUNHILL

UNITED ARTISTS
ASCOT
BEAT
PRESTIGE
VANGUARD (Wisc.)
WORLD ARTISTS
RIC

CRUSADERS
MUTUAL
BEAM
CONTACT

GARMISA DISTRIBUTING CO., INC.

1303 So. MICHIGAN AVE., CHICAGO 5, ILL.

ALL PHONES: 922-7455

HAPPY 23rd ANNIVERSARY

BEST
&
GOLD

RECORD DISTRIBUTORS

959 Main Street, Buffalo, New York

TT 2-0427

Leonard Silver

Steve Brodie



mickie most

herman's hermits
the animals
the cherokees
the symbols
the moquettes



record promotion:
pete bennett

direction:
allen klein

time & life building
new york, n.y.

DISTRIBUTORS RECORD

and the lines they handle

MASSACHUSETTS (continued)

CAMBRIDGE

The Eastern Co.
620 Memorial Drive
A. J. Shuffer—TR 6-4720
(RCA Victor)

MICHIGAN

DETROIT—(317)

Arc Dist. Co.
13415 Lyndon
Henry Droz—BR 2-4872
(ABC Paramount, Audia Fidelity, Camea, Coed, Command, Congress, Diamand, End, Gone, Grand Award, Guyden, Hi, Imperial, Impulse, Jamie, Jay Jay, Kapp, Laurie, Living Language, Motown, Musicar, Original Sound, Parkway, Philles, Roulette, Rust, Starday, Swan, 20th Century Fox, United Artists, Westminster, Apt, Tangerine, Music Guild, Calla, Crescendo, Enterprise, Fiesta, Legrand, London, Porrot, Reprise, Ric, Soul, Tollie, Warner Bros.)

Cadet Dist. Co. Inc.
13380 Capital Avenue
Harry Levin—548-3171
(Challenge, Chattohochie, Contemporary, Disneyland, Doota, Dolton, Good Time, Jazz, Liberty, Monitor, Sovoy, Specialty, Sun, Universe, Vista, World Pacific, Aura, Budapest, Drummond, Pacific Jazz)

Capitol Records
18421 Wyoming
Jim Blackwood—UN 4-5001
(Capitol, Angel)

Columbia Record Dist.
16141 W. 8 Mile Road
Larry Owen—273-8616
(Columbia, Masterwork Phonographs)

Decca Dist. Corp.
12730 Puritan
Mario DeFilippo—DI 1-6040
(Decca, Coral, Brunswick, Vocalion, Listen & Learn)

Jay-Kay Dist. Co.
13401 Lyndon Ave.
John S. Kaplan—272-7001
(Atlantic, Cross-Country, Dot, Headline, Kent, Mercury, Smash, Soma, Somerset, Sterea Fidelity, Time, Trade, Vanguard, Vee Jay, Verve, Ara, Audia Spectra, Avo, Bang, Bolo, Chorler, Cumberland, Custom, Dial, Eastern, Etiquette, Everyman, FM, Focus, Fontana, Garrett, Golden Ring, Homilton, Heidi, Hilltop, Horizon, Interphon, Jerk, Lupine, Mainstream, Mercury Players, Metro, MGM, Music City, Palmer, Parker, Philips, Pickwick 33, Planetary, Regina, Rosemart, Sofice, Simpson, Sims, Stax, Stereo-Motion, Uptown, Wing, World Artists)

Merit Music Dist. Inc.
15773 Wyoming
John H. Schlee—UN 3-9119
(Tama, Gordy, Soul, Manument, Saund Stage, Hickory, Fraternity, Dance-A-Long, Golden World, A&M, Adventure, Alma, Amphora, Amy, Mala, Aurara, Bell, Colonial-Standard, Constellation, Custom, Dearborn, DynaVoice, Flashback, Melody, Modern, Money, Music Minus One, Pan, Red Bird, Sphere, Stena Disc, Sun-glow, TCF, Valiant, Village Gate)

Music Merchants, Inc.
3731 Woodward Ave.
Marvin M. Jacobs—832-0870
(Argo, Caedmon, Checker, Chess, Colpix, Crusader, Dimension, D-Town, Epic, Everest, Fantasy, Gateway, Folkways, Okeh, Old Town, Prestige, U.S.A., American Arts, Atco, Autumn, Blue Cat, Blue Rock, Charger, Canadian American, Dana, DCP, Ero, Enjoy, Favar, Jewel, Josie, Life, Limelight, Moonglow, Port, Tuba, Veep, Volt)

Radio Dist. Co.
15470 Schaefer Hwy.
George MacDuff—273-6740
(London, Richmond, Telefunken, Argo, L'Oiseau, Lyre, Palomar, Coliseum)

RCA Victor Dist. Co.
7400 Intervale Ave.
N. A. Corbett—TE 4-3500
(RCA Victor, Camden, RCA Victrola, RCA Graave)

Record Dist. Corp.
3757 Woodward Ave.
Armen Boladian—831-6430
(Arctic, Back Beat, Bellina, Gallo, Conversa Phane, Creed, Day-Dell, Duke, Elektra, Euratane, Exello, Hyland, Jerden, Linda, Mace, Nashboro, Nina, Nonesuch, Peacock, Bolly, Rampart, Ring, Rotote, Scepter, Sang Bird, Shinson, Sure Shot, Syca, Thelma, Wand, Was-sel, Wild Deuce, Fax, Riot, Humorsonic, Ronik)

Superior Record Dist. Corp.
3727 Woodward Ave.
Joseph Goleski—TE 3-4700
(Atco, Canadian American, Dana, Dorem Eram Hi Fi, Life, Josie, Jubilee Crown, Port, Vault, Valt, Cross, B.T. Puppy, Coronet, Monogram, Am Can)

MINNESOTA

MINNEAPOLIS—(612)

Capitol Records Dist. Corp.
6150 Wayzata Blvd.
Paul V. Goetz—LI 5-1671
(Capitol, Angel)

Columbia Midwest
119 No. 9th St.
Amos Heilicher—FE 3-8281
(Columbia, Epic)

CHAPMAN DISTRIBUTING CO. LA's Newest Distributor

Al Chapman, with 30 years of record experience is now happy to announce his own record distributing organization.

Manufacturers' inquiries most welcome. Your product deserves personal attention

Contact:

CHAPMAN DISTRIBUTING CO.

2645 W. Pico Blvd. Los Angeles, Calif. 90006
Phone 385-3636

INDEPENDENT RECORD SALES & JERRY DENNON

An unbeatable team in the Northwest!
Promotion-Concentration-Effectiveness

INDEPENDENT RECORD SALES

Division of Craig Corporation

1021 East Pine Street Seattle, Washington 98102
EAsT 4-3939

NEW JERSEY'S LEADING
INDEPENDENT DISTRIBUTORS

ESSEX RECORD DISTRIBUTORS

10 FENWICK ST.

NEWARK 12, NEW JERSEY

201-BI 3-7700

- ★ UNMATCHED RECORD OF PROMPT AND EFFICIENT SERVICE
- ★ MERCHANDISING KNOW-HOW
- ★ DEPENDABILITY
- ★ PROMOTIONAL STAFF TO HELP YOU SELL AND PROFIT

house of hits

EXCLUSIVE
DISTRIBUTORS
for the
BEST-SELLING
LABELS



HARRY ROSEN, Vice-Pres.
DAVID ROSEN, INC.
855 N. BROAD ST., PHILA., PA. 19123
Phone: (215) CEnter 2-2900

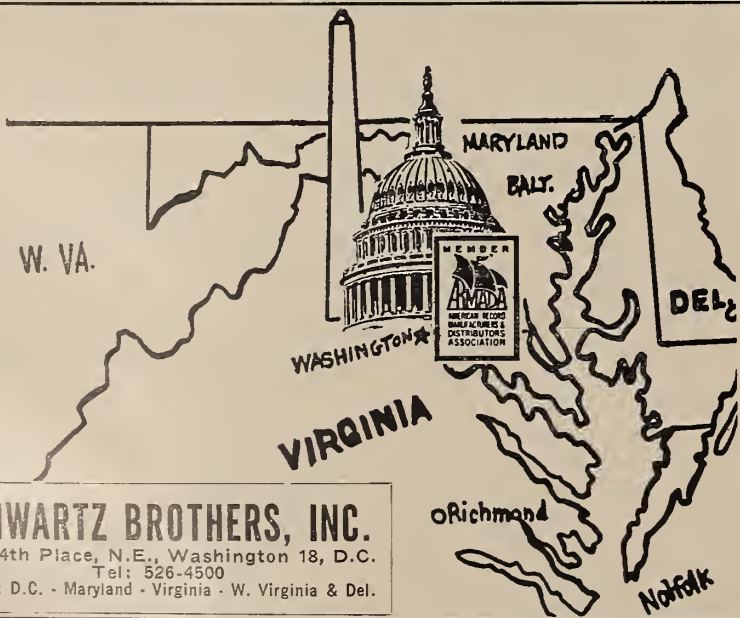

SCHWARTZ BROTHERS, INC.
2146 24th Place, N.E., Washington 18, D.C.
Tel: 526-4500
serving: D.C. - Maryland - Virginia - W. Virginia & Del.

when answering ads . . .
SAY YOU SAW IT IN CASH BOX



mickie most

calvin james
ron & mel
the measles

exclusively



record promotion:
pete bennett

direction:
allen klein

time & life building
new york, n.y.

Best Wishes to Cash Box on
Your 23rd Anniversary

RECORD MERCHANDISING COMPANY, INC.

2580 West Pico Blvd.
Los Angeles, California 90006
385-9161

IN NEW YORK—THERE'S ONLY ONE

SUPERIOR

DISTRIBUTORSHIP WITH KNOW-HOW

SUPERIOR RECORD SALES CO., inc.

SUPERIOR SALES FORCE • SUPERIOR SALES MERCHANDISING • SUPERIOR PROMOTION
CREATE HITS — CREATE SALES — SELL MERCHANDISE

SAM WEISS, Pres. MATTY MATHEWS, Promo. Mgr.
429 West 49th St., New York 19, N.Y. (212) CI 5-3655-6-7

FOR DISTRIBUTION IN
PHILADELPHIA

You Can't Match

Chips

CHIPS DISTRIBUTING CORP.

808 NORTH BROAD STREET, PHILADELPHIA, PA 19130 (215) POPLAR 9 5000

Al Rosenthal



RECORD DISTRIBUTORS

and the lines they handle

MINNESOTA (CONT'D)

Heilicher Bras. Inc.
7600 Wayzata Blvd.
Amas Heilicher—544-4201
(Amy, Archive, Argo, Atco, Atlantic, Audiophile, Coedmon, Canadian American, Caprice, Challenge, Chottohoochie, Checker, Chess, Childcraft, Coed, Colonial, Colpix, Commond, Congress, Crackerjack, Crescendo, Cricket, Crestview, Crusader, Cumberland, Dart, Deutsche Grammophon, Diamond, Dimension, Dolton, Dore, Duo, Double L, Design, Duke, Era, Elektra, Epic, Everest, Fabor, Fiesta, Folkways, Fontona, GNP, Garrett, Golden Ring, Golden, Grand Award, Gregmark, Horizon, Hilltop, Imperial, Joy Jay, Josie, Joy, Jubilee, Laugh Time, Lourie, Liberty, Limelight, Living Library, Molo, Mercury, Minit, Monogram, Music Minus One, Moonglow, Marc, Moxx, Nonesuch, Philips, Peacock, Peter Pan, Playcraft, Red Bird, Riot, Riviera, Reprise, Scepter, Sermon, Select, Smash, Somo, Somerset, Stereoditties, Stax, Sue, Surprise, Symbol, Tollie, Time, Tri-Disc, 20th C-F, Theatre Productions, Valiant, Vee Jay, Vault, Volt, Wand, Warner Bros., Wing, Aro, Audio Fidelity, Audia Spectrum, Auroro, Autumn, Backbeat, Bell, Big Hill, Blue Cat, B.T. Puppy, Charger, Constellation, Dial, Disneyland, Fome, Focus, Goteway, Golden Crest, Good Time Jazz, Hall, Herald, Hi Fi-Life, Interphone, Lomo, Mainstream, Money, Music Voice, Mutuol, Okeh, Paulo, Providence, Ric, Rosemont, Sims, Standard, Storyteller, Triumph, Vista, World Artists)

Jather Dist. Corp.
730 Lyndale Ave. N.
Jack A. Taylor—374-3420
(A&M, Del Fi, Hickory, Jomie/Guyden, Montel, Stordoy, Sun, United Artists, Almo, Ascot, Auro, Blue Note, Chart, Contempo, CRG, DCP, FSR, Lodestor, Musicor, Pacific Jazz, Prestige, Shasta, Specialty, SRC, Summit, Tom Lehrer, Rainbow)

Harold N. Lieberman Co.
257 Plymouth Ave. N.
Al Abrams—322-7131
(ABC Paramount, Ava, Chancellor, Cameo, Dot, Golden World, Hi, Impulse, Kapp, London, MGM, Parkway, Sound Stage, Vonguard, Apt, Tangerine, Bach Guild, Best, Boss, Chairman, Charlie Parkerm Charter, Coliseum, Dos Alte Werk, Domaine, Felsted, Folk Sing, Four Corners, Group, Hamilton L'Oiseou-Lyre, London-Argo, Ric Tic, Seville, Sierra, Sound & Songs of Nature, SPQR, Sports International, Story Time, Swan, Telefunken, Tower, Tribe, Twin Town, Valiant, Verve)

MISSOURI

KANSAS CITY—(816)

Capital Records Dist. Corp.
701 E. Linwood Blvd.
J. Swensen—JE 1-0435
(Capitol, Angel)

Choice Records Dist.
321 S. W. Blvd.
Harold Hassler—HA 1-2546
(King, Hickory, Sun, Stardoy, Folly, Chart, Golden World, Crown)

Commercial Music Co.
3230 Roanoke Rd.
Wm. Muncy—FR 1-1317
(Colpix, Challenge, Contempo, Diamond, Epic, Gee, Merc, Musicor, Okeh, Roulette, Sun Swan, Tico, UA, WB, World Pacific, Living Language, After Hours, End Gone, Good Time Jazz, Living Literature, Betty White Dance, Mor V Lus, Phillies, Philips (Nashville) Reprise, Roost, Pacific Jazz, Young Peoples Records, Childcraft, Merc, Wing, Pic-A-Disc Rec. Rocks, Plotterpok Cases, Fidelitytone Needles & Acc., Walco Needles & Symphonic Record Players.

Decca Dist. Corp.
2729 Gillham Rd.
Carl Wayne—Grand 1-4030
(Decca, Coral, Brunswick, Caedmon, Listen & Learn Language)

ST. LOUIS—(314)

Capital Records Dist. Corp.
2201 59th St.
Ray Walker—MI 7-1285
(Angel, Capitol)

Columbia Record Dist.
2151 59th St.
Bob Van Metre—MI 7-5101
(Columbia, Harmony, Masterwork Phonographs)

Commercial Music Co.
2721 Pine
Bud Lampe—JE 5-1515
(After Hours, Challenge, Colpix, Contempo, Diamond, End, Epic, Gee, Gone, Goodtime Jazz, Living Language, Living Lit, Betty White Dance, Mar-V-Lus, Merc, Musicor, Okeh, Phillies, Philips, Reprise, Roulette, Sun Swan, UA, WB, Roost, Tico World Pacific, Pacific Jazz, YPR, Child Craft, Wing, Also: Pick-A-Disc Racks, Plateepok, Cases, Fidelitytone Needles & Acc., Walco Needles, Symphonic Record Players.

Decca Dist. Corp.
1905 Delmar
Max Melton—CE 1-6600
(Decca, Coral, Brunswick, Listen & Learn)

Interstate Supply Co.
4445 Gustine Ave.
R. N. Decker—VE 2-600
(RCA Victor, RCA Comden, Caedmon)

La Mar Dist. Co.
1917 Delmar
Paul Levy—GA 1-1938-9
(ABC Par, Impulse, Music Guild, Robin Hood, Vanguard, Westminster)

Midwest Dist. Co.
1917 Delmar
Paul Levy—GA 1-1938-9
(Atko, Audio Fidelity, Cadence, Command, Crown, Elektra, Fleetwood, Grand Award, Ideol, Kent, Mr. Maestro, Nonesuch, Phillies, Specialty, Stereoditties)

Record Merchandisers Inc.
1919 Delmar Blvd.
Alfred L. Chatin—MA 1-0966
(A&M, Almo, Bethlehem, Coed, Cumberland, Everest, Excello, Favor, Fantasy, Federal, Fiesta, Fontona, Galoxy, Gordy, Gospel, Hickory, Jay, King, Limelight, Motown, Nashboro, Onederful, Phillips, Sor, Savoy, Scepter, Shorp, Smash, TCF, Tamlo, 20th C-F, Wand, Atco, Audio Fidelity, Audio Spectrum, Blue Rock, Brooklyn Celeste, Chart, Coronet, Crusader, D-Town, Design, Diplomat, Gateway, Grand Prix, Greophone, Guest Stor, Happy Time, Heidi, Hob, Kent, Mace, Moonglow, Money, Nashville, Peter Pan, Pickwick, Rotote, Somerset, Soul, Spinoromo, Tolly, Valiant, Vault, V.I.P., Wild Deuce)

Roberts Record Dist. Co.
1902 Washington Ave.
Robert Hausfater—MA 1-0470
(Amy, Molo, Moxx, Atlantic, Blue Note, Stax, Cameo Parkway, Canadian American, Chess, Checker, Argo, Constellation Dimension, Duke Peacock, Herald Ember, Era Fraternity, Congress, GNP, HIFI, Jamie, Guyden, Jubilee, Kopp, Laurie, London, MGM, Verve, Old Town, Monument, Stardoy, Sue, Time, Vee Jay, World Artists, Ric, Red Bird, Tollie, Norman, Hi, Montel, Golden World, Arlen, Rust, Aro, Backbeat, DCP, Disneyland, Dooto, DGG, Fame, Four Corners, Golden Gold Wax, Interphon, Folkways, Josie, Legend, Life, L'Oiseou-Lyre, Mainstream, Modern, Mutual, Nashville, Parrot, Prestige, Rompart, Rose Mort, Sound Stage, Tower, Visto, Wyncote, King, Federal.)

Tower Record Distributors
2025 E. Grand, P.O. 6391
Steve Tatten—CH 1-0950
Big Country, Copo, Chart, Fabor, Fortune, GP, Groot, Jomeco, J&S, Longhorn, Music Center, Neb's Robbins, Sellite, Specialty, St. Lawrence, Topic, Wheel-City, Zella's.)

MONTANA

GREAT FALLS—(406)

Music Service Co.
316 6th St. So.
R. E. Ham—761-2420
(Argo, Challenge, Colpix, Dolton, Dot, Epic, Everest, Fabor, Hi, Imperial, Laurie, London, MGM, Smosh, Stardoy, Stereoditties, Sun, Valiant, Vanguard, Verve, Warner Bros., Reprise, Philips, Hilltop, Hamilton, Nashville, Monument, Okeh, Autumn, American Artists, Cimmaron, Cumberland, Dimension, Fontona, Jay Jee, Limbo, Liberty, Polomor, Porrot, Phillies, Tribe, World Artists)

HELENA—(406)

D. N. Latus & Co.
Airport Rd.
Art Battershell—442-3940
(Audio, Fidelity)
(Continued on next page)

Best Wishes
from
California Record Distributors

3009 W. Pico Blvd. • Los Angeles, Calif. 90006 • RE 18601

Ralph Kaffel
President & Gen. Mgr.

Stan Bly
Promotion Director



andrew loog oldham

the rolling stones

record promotion:
pete bennett

direction:
allen klein

time & life building
new york, n.y.



**SALES SOAR
IN THE
SUNSHINE
STATE**

WITH

TONE

DISTRIBUTORS INC.

495 South East 10th Ct., Hialeah, Fla.

(TU 7-7546)

HENRY STONE — MILT OSHINS

Congratulations To **CASH BOX**
**MANUFACTURERS LOOKING
FOR A CHANGE?**

OVER **50** YEARS SERVICE
IN THE INDUSTRY

TONY GALGANO
RUBE LAWRENCE

RECORD DISTRIBUTORS

4135 West Armitage
Chicago 39, Ill. / Dickens 2-7060

Lou Klayman, Manny Wells, Al Levine present

RECORD RIOT
on **LONG ISLAND**

created by Imaginative
Distributors with
Service and Sales Ideas

now featuring:

- Audio Spectrum
- Bang
- Mainstream
- Somerset
- Status
- Stereo-Fidelity
- Time
- Tower
- Universe

Gen. Mgr. Morris Weissman; Sales Mgr. Peter Hyman

STATES RECORD DISTRIBUTING CORP.

a division of Interstate Record Dist., Inc.

182-20 Liberty Avenue, Jamaica, Queens, N.Y. 11412 (212) 454-1000

**RECORD
DISTRIBUTORS**

and the lines they handle

NEBRASKA

OMAHA—(402)

Jather Dist. Corp.
2500 Horney St.
Darwin—342-1545
(Apollo, Bigtop, Borderline, Bull, Cameo, Conversaphone, Del Fi, Dooto, Ember, End, Goldisc, Guyden, Herald, Hickory, Jamie, Kem, Tom Lehrer, Living Language, Musicor, Omega, Parkway, Rainbow, Specialty, Starday, Summit, Sun, UA, Verve, Westminster)

Sidles Co.
7302 Pacific St.
Ralph Woodward—393-2233
(RCA Victor, RCA Camden)

NEW JERSEY

CAMDEN—(609)

Decca Dist. Corp.
1722 Federal St.
Sam Passamano—966-7111 WA 2-5659
(Brunswick, Coral, Decca, Listen & Learn)

NEWARK—(201)

All State-New Jersey
321 Sherman Ave.
Irwin R. Fink—242-6500
(Ascot, Atco, Brooklyn, Colosium, Four Corners, Feksted, Garrett, Hi, Heidi, Joy, Kapp, London, Monument, Moonglow, Musicor, Palomar, Porrott, Richmond, Select, Seville, Sound Stage 7, Telefunken, Tivoli, Tribe, United Artists, Volt)

Apex-Martin Record Sales Inc.
351 Washington St.
Joe Martin—MA 3-7231
(Amy, Cracker Jack, Choice, Dimension Epic, Everest, Fontasy, Gordy, Galaxy, Guyden, Hollywood, Jamie, Joy Joy, Mala, Motown, Onderful, Okeh, Pacific Jazz, Philles, Relic, Rampart, Sue, Symbol Starday, Somerset, World Pacific, A&M, Aura, Almo, Amer. Artists, Arctic, Audio Spectrum, Aurora, Amer. Gramophone, Broadway, Bell, Bang, Blue Rock, Big Hill, Crown, Crusader, Choitohoochee, Charger, Collam Carnival, Catomount, Day Dell, Destination, DW, Dynovoice, D-Town, Enjoy, Eastern, General-American, Golden World, Gateway, Gool, Holly, Halo, Highway, J&S, Kay-O, Kent, Landa, Lindo, Maxx, Mr. Maestro, Mike, Marton, Modern, Mar-V-Lous, Marvel, Nahville, Orbit, Lost Nite, Phi-Dan, Riviero, Soul, Skymac, Sphere Sound, Sabra, TCF, Tuba, U.S.A., World Artists, Wingate, Zell's)

Capitol Record Dist. Corp.
72 Central Ave.
MA 3-7086
(Capitol, Angel)

Essex Record Dist. Inc.
10 Fenwick St.
Joe Cohen—BI 3-7700
(ABC Paramount, Argo, Atlantic, Audio, Fidelity, Avoca, Blue Note, Checker, Chess, Coed, Colonial, Copley, Diplomat, Duke, Excello, Legrand, Nashboro, Gospel, Hull, Impulse, Laurie, Legrand, Nashboro, Old Town, Original Sound, Peacock, Peter Pan, Red Bird, Roulette, Sar, Sovoy, Scepter, SPQR, Standard, Stella, Sun, Swan, Tico, Tollie, Vee Jay, Wand, Apt, Backbeat, Blue Cat, Champion, Constellation, Dial, Diamond, Dooto, Flip, Focus, Fraternity, Golden, Golden Goodies, Goldwax, Hob, Lupine, Moce, Money, Oldies, Regent, Sharp, Specialty, Tax, Shur Shot, Tangerine, Tower, Tuff, Uptown Vivid)

Ideol Record Prod.
357 Lyons Ave.
Jack Kosloff—WA 3-6333
(Alector, Bruno, Caedmon, Cook, Fargo, Fiesta, Golden Crest, Gold Star, Headline, Helios, Simon Says, Time, Vesuvius, Disc-O-Mate, Fortune)

Laredy Record Dist. Corp.
46 Green St.
Joseph Fechner—MA 3-5845
(Aravel, Challenge, Command, Conversaphone, Disneyland, Eurotone, Grand Award, Tom Lehrer, Living Language, Living Literature, Reprise, Tradition, Vista, Warner Bros., Young Peoples Records, DCP, Evergreen, Loma, Rodeo, Sure, Veep)

Wendy Dist. Inc.
37 William St.
Jerry Winston—MA 3-5845
(Cameo, Can. Amer., Dolton, Elektro, Era, Imperial, Contemporary, Liberty, Life, Mardi-Gras, Mainstream, 20th C-F, Parkway, Nonesuch, Ric, Arvec, Autumn, HIFI, GNP Crescendo, JJC Prod., Prestige, Wyncote, Audio Fidelity, King, Federal, Deluxe, Bethlehem.)

NEW YORK

ALBANY—(518)

Delta Record Dist.
1260 Broadway
Robert E. Devere—HO 2-6564
(Autumn, B. T. Puppy, Backbeat, Bell, Bethlehem, Big Hill, Blue Note, Blue Rock, Comeo, Canadian American, Challenge, Chattahoochee, Coed, Colpix, Congress, D-Town, Dono, Derby, Dimension Duke, Duo Disc, Era, Eastern, Excello, Fabor, Federal, Folkart, Folkways, GNP Crescendo, Gateway, Goal, Golden World, Gordy, Gospel, Hickory, Hob, Josie, Jubilee, Joy, Kent, King, Laurie, Legrand, Legend, Mainstream, Magnun, Mala, Mar V Lus, Maxx, Modern, Monitor, Monument, Motown, Mutual, Nasco, Nashboro, Oldtown, Onederful, Original Sound, Parkway, Peacock, Phillies, Rampart, Regent, R I C, Riviera, Rotate, Rust, Sor, Savoy, Scepter, Sharp, Sims, Soma, Sound Stage 7, Soul, Specialty, Sue, Swan, Swing, Symbol, Tamla, Tollie, Tradition, Wand, World Artists. Also: Recoton Needles & Accessories, Oak Publ.)

Jay-Ess Distribs
98 Everett Rd.
Joseph Spence—482-5558
(Celeste, Chort, Dearborn, DeVille, Dooto, Gary, Glenn, Great, J&S, JJC, Jomeco, Longhorn, MMO, Piccolo, Primus, Ric, Sahara, Sounds of Nashville, Sunglow, Vordon, Vulcan, Zebro, Zell's)

RTA Dist. Co.
991 Broadway
Harry Griffith—HO 5-7346
(RCA Victor, RCA Camden.)

Leonard Smith, Inc.
30 No. 3rd St.
Leonard Smith—HO 2-6506
(Audio Fidelity, Bach Guild, Cadence, Colpix, Fiesta, Fleetwood, MGM, Music Minus One, Philips, Starday, Hilltop, Stella, Sun, Vonguard, Verve, Vox, Vesuvius.)

BUFFALO—(716)

Best & Gold Record Dist.
956 Main St.
Leonard Silver—TT 2-0427
(A&M, Adams, After Hours, Amy/Mala, Arlene, Atco, B. T. Puppy, Cameo/Parkway, Carlton, Caed, Congress, Cortland, Crescendo, Crown, Crusader, Dana, Daisy, Dorcy, Delfi, Diamond, Dimension, Disneyland, Duke, Enjoy, Epic, Era, Everest, Favor, Fernwood, Fraternity, Glover, Golden World, Gospel, Guyden, Jamie, Jay Jee, Jay Jay, Jubilee, Kandy, Kapp, KC, Kent, Mainstream, Montel, Motown, Nashboro, Newtown, Old Town, Onederful, Pacific, Peacock, Philles, Red Bird, Roulette, Sandy, Sar/Derby, Savoy, Scepter, Sherman, Squire, Stacu, Starday, Strand, Sue/Symbol, Sun, Tear Drop, Theater Prod. Time, Tri Disc, Universe, USA, Vista, Village, Wand, West Coast, ABC Paramount, Angle, Argo, Atlantic, Bardell, Blue Note, Cadence, Checker, Chess, Cimarron, Colpix, Dooto, National, Original Sound, Mercury, Philips, Prestige, Sahorah, Sim's, Smosh, Stacy, Swan, Thunderbird, Tuff, Vee Jay, Beverly, Westminster, World Artists.)

Capitol Record Dist. Co.
375 Nagel Dr.
Chos. A. Dolak—NT 3-5000
(Capitol, Angel.)

Delta Records
892 Main Street
Carl Gerace—884-2990
(A&M, Blue Rock, Canadian American, Chattahoochee, Clock Records, D-Town, Duo Disc, Eastern, Gordy, Hickory, Hob, Kent, Laurie, Legrand, Mace, Magnum, Mainstream, Motown, Musicor, Mar V Lus, Madern, Old Town, Onederful, Providence, R I C, Rust, Scepter, Sims, Soul, Sue, Symbol, Tamla, Tower, VIP, Wand.)

NEW YORK CITY—(212)

Allstate Distribs.
619 W. 56th St.
Irwin Fink—JU 2-5944
(Ascot, Joy, Kopp, Ringo.)

Alpha Dist. Corp.
20 West End Ave.
Harry Apostoleris—CI 5-7933
(A&M, Alector, Almo, Ansonia, Aravel, Avoca, Challenge, Checker, Chess, Colonial, Eurotone, Everest, Fleetwood, Crescendo, Hickory, Hull, Italidisc, Mana Lee, Nam, Nina, Original Sound, Pacific Jazz, Reprise, Request, Stordard, Stella, Stereoaddities, 20th CF, Valiant, Warner Bros., World Pacific, Argo, Autumn, Congress, Counterpoint, DCP, Disneyland, Esoteric, Four Corners, Jay Jay, JJC, Money, Mar V Lus, Ponort, Loma, Starday, Veep, Vista, Tamla, Matown, Gordy.)

(Continued on next page)

**WE STILL GIVE
THE BEST COVERAGE
IN
DETROIT & MICHIGAN**

CADET DISTRIBUTING CO., INC.
13380 CAPITAL AVE. — Tel: 548-3171
OAK PARK, MICH. 48237



the rolling stones

recording director:
andrew loog oldham

British Decca

u.s.a. direction:
allen klein

time & life building
new york, n. y.

Manny Wells, Lou Klayman, Al Levine say:

"WE SUCCEEDED BY TRYING!"

Florida's Most Creative, Experienced Selling Team Adds Up To...

**CONTENTED CUSTOMERS
PLUS EXCLUSIVE
REPRESENTATION FOR
THESE TOP LABELS...**

Hanna Barbera	GrecaPhone	Main Stream
MGM	DGG	Vista
Verve	Command	Motown
Disneyland	Living Language	Amy-Mala
Tower	Time	GNP-Crescendo
		Tico

contact: Morty Marks, Manager

FLORIDA RECORD DISTRIBUTORS, inc.

A Division of Interstate Record Dist., Inc.
8160 N.W. 36 Avenue, Miami 47, Florida (305) 696-4951

FAST DISTRIBUTION

FOR AMERICA'S **FASTEST** SELLING RECORDS!

A & I

RECORD DISTRIBUTORS

1000 Broadway, CINCINNATI 2, OHIO

AGGRESSIVE SALES AND PROMOTION...

JOE NATHAN, GENERAL MANAGER

NOW

MORE THAN EVER! FOR SOLID, INDEPENDENT DISTRIBUTION IN SAN FRANCISCO IT'S

INDEPENDENT MUSIC SALES

A DEPARTMENT OF H. R. BASFORD CO.

Paul McKimmie, Manager—Denny Zeitler, Promotion Manager

INDEPENDENT MUSIC SALES

235 15th St., San Francisco, Calif.
Area 415 MA 1-8545

If you are with INDEPENDENT in SAN FRANCISCO you have—

- A hungry distributor
- with money
- the finest promotion
- top sales know-how
- exclusively a distributor
- giving the indies their best distribution on the West Coast.

RECORD DISTRIBUTORS

and the lines they handle

NEW YORK CITY (CONT)

Argus Record Dist.
500 W. 51st St.
Rose Saggio—765-2585
(Agon, Criterion, Dragon, Ron, Riccio, Barracuda, Beacon, Change, Chubby, Cu Rae, Kevin, Lee, Perico, Ric, Tina, Van.)

Guy Barry Dist.
13 Welsey Dr.
FR 4-6772
(Latin American International.)

Bruno-New York
460 W. 34th St.
Phil Silverman—LO 4-2425
(RCA Victor, RCA Camden, RCA Victrola, RCA Groove.)

Canal Record Dist.
50 Canal St.
Saul Karp—WA 5-9010
(Gale, Famous, Vision & Sound.)

Capitol Record Dist. Co.
317 W. 44th St.
Ben Savoia—CI 5-3900
(Capitol, Angel.)

Columbia Record Dist.
545 Madison Ave.
Donald England—HA 1-4700
(Columbia, Harmony, Masterwork Phonographs.)

Cosnat Dist. Corp.
315 W. 47th St.
Mike Lipton—PL 7-8140
(Atco, Atlantic, Baronet, Borderline, Coronet, Crown, Dana, Dot, Gala, Glory, Gross, Hamilton, Indigo, Jubilee, Josie, Malibu, Monogram, Norman, Port, Samson, Stax, Todd, Triad, Trutone, Volt, Winley.)

Decca Distrib.
51-11 Queens Blvd.
James McDonald—HI 6-7474
(Decca, Coral, Brunswick, Vocalion.)

Hector Dist. Co.
333 6th Ave.
Stan Cumberpatch—CH 2-1989
(Aeolian Skinner, Academy, Arhoolie, Audiophile, Bert & I, Boston, Distinguished, Educo, Jazzology, Lexington, Music Library, Original Jazz, Piedmont, Southland, Spo, Austin, Blues Classics, Cantate, Cook, Dorian, Evergreen, Fidelity Sound Recordings, GHB, Haydn Soc., Mea, Mobile, Murnil, Rococo, Toad.)

Ideal Record Products, Inc.
171-07 Jamaica Ave.
Bill Singer—Sam Keenholz—AX 1-8700
(Tom Lehrer, Distinguished, Helios, Gold Star.)

Jet Record Dist. Corp.
40-11 Skillman Ave.
Long Island City
Walt Lam—ST 6-0677
(ABC Par, Command, Contact, Hi Fi, Impulse.)

London Record Dist. Co.
207 W. 52nd St.
Phil Wesen—AL 5-8350
(C.G.D., Coliseum, Hi, London, London International, Monument, Palomar, Parrot, Press, Seville, S.P.Q.R., Tribe, Watch.)

Met Record Dist.
2155 Utica Ave.
RN 3-1212
(Alma, Norca, Eddisa, Seeco, Tropical, BBM, Mona, Colonial.)

Metro Distribs.
547 W. 52nd St.
Dave Seidman—CO 5-1871
(MGM, Verve, Swan, VeeJay.)

Multi Disc of New York
524 W. 43rd St.
Stan Drayson—LA 4-6666
(Mercury, Phillips, Smash, Fontana, Cumberland, Wing, Limelight.)

Olympia Dist. Corp.
237 W. 18th St.
Ervin Litkei—989-7200/1/2/3

(Ambassador, Aurora, Duna, Galiko, Kelit, Budapest, Golden Records, Disc'ador, Guest Star, Somerset, Little Golden, Stadium Request.)

Partem Dist. Inc.
601 W. 50th St.
Gladys Pare—PL 7-0070

(Amy, Aurora, Banshee, Bell, Blue Note, Cab, Cabot, Calico, Canadian American, Carnival, Cook, Crown, Delmark, Dore, Enjoy, Epic, Era, Jameco, Flashback, General American, Gospel, Headline, K&H, Lost Nite, Mola, Maestro, Moxx, Nebs, Okeh, Parkway, Prestige, Regent, Relic, Roost, Sor, Savoy, Sharp, Son Novo, Sphere, Testament, World Artists, World Wide, Wyncote.)

Stanley Lewis Record Dist. Co.
534 W. 58th St.
Harry Lew—CO 5-7955

(Archive, Bachguild, Bartok, Boite A Musique, Baroque, Coedmon, Cambridge, Cetra, Classic Editions, Composers Recordings, Credo, Cricket, Deutsche Grammophon, Dyer Bennet, Dover, Ems, Eterna, Experience Anonyme, Ficker, Folkways, Gregorian Inst., Instant Language, Lyrichord, Music Guild, Broadside, Lexington, Monitor, Montilla, Motivation, Musica Sacra, Music Minus One, Olympus, Overtone, Oak Publications, Period, Pathways of Sound, Proscenium, Rainbow, Renaissance, Rutgers Music Dictation, Scala, Spa, Spoken Word, Spoken Art, Stradivari, Tradition, UTC, Vanguard, Westminster, Voix de L'Arteur, Avakion, Piedmont, Vox.)

Superior Record Sales Co. Inc.
424 W. 49th St.
Sam Weiss—CI 5-3655/6/7/8

(Alegre, Audio Fidelity, Coed, Dooto, Fania, Fantasy, Jamie, Kent, Nashboro, Old Town, Phillies, Riverside, Federal, Deluxe, King, Bethlehem, Remo.)

SYRACUSE—(315)
Capitol Records Dist. Corp.
627 W. Genesee St.
M. Takki—427-6344
(Capitol, Angel.)

Columbia Record Dist.
218 Harrison St.
Irwin Medway—474-2901
(Columbia)

Morris Dist. Co.
1153 W. Fayette St.
Oscar Dachs—GR 5-6537
(RCA Victor, Mercury.)

Gerber Dist. Co. Inc.
313 Herald Place
Wm F. Gerber—471-2118

(Ascot, Audio Fidelity, Bach Guild, Conversaphone, Contempo, Command, Dountless, Design, DCP, Fantasy, Folkways, Galaxy, Garex, Gaylord, Golden, Happy Time, Komo Sutra, Living Language, Metro, MGM, Monument, Pickwick, Prestige, Reprise, Somerset, Sound Stage 7, Stereo Fidelity, Status, 20th CF, United Artists, Vanguard, Verve, Warner Bros., Young People's Records.)

NORTH CAROLINA

CHARLOTTE—(704)

Arnold Dist. Co.
2704 Freedom Drive
Bert Fleishman—399-9741

(Arock, ABC Paramount, Atco, Apt, Comeo, Canadian American, Challenge, Chancellor, Chattahoochie, Crackerjack, Del Fi, Donna, Dooto, GNP, Crescendo, Hull, Impulse, Lehrer, Parkway, Prestige, Reprise, Scepter, Sue, Symbol, Tangerine, Music Guild, Valiant, Voly, Wand, Warner Bros., King, Federal, Deluxe.)

Bertas Sales Corp.
2214 W. Moorehead St.
Phil Goldberg—375-2517/2518

(Argo, Chess, Checker, Epic, Command, Excello, Gordy, Jubilee, Motown, Okeh, Soma, Ascot, VIP, Tomlo, United Artists, VeeJay, Tollie, Constellation Verve, Starday, Nashboro, Colpix, Melody, Grand Award, Smash, Blue Cat, Red Bird, Gold Wax, Project, Charger, Hilltop, Nashville, Cumberland, Fontana, Soul, Paula, Fame, Liberty, Dolton, Valiant, Imperial)
(Continued on next page)



FOR FAST & EFFICIENT RECORD PRESSING & NATIONAL DISTRIBUTION OF INDEPENDENT LABELS contact:

Sound of Nashville, Inc.

160 2nd Ave. South
Nashville, Tenn. 37201
Phone 244-1124





the dave clark five



record promotion:
pete bennett

eros international corp.
time & life building
new york, n.y.

HECTOR

Is Your Source for Over 300 Hard to Locate Domestic and Foreign LP Labels.

RETAIL STORES

U.S. and Canada:
Order Labels from Hector
Which You Can't Get from Your
Local Distributors

MANUFACTURERS

(without complete nationwide distribution):

- Hector Does Not Compete With Your Present Local Distributors.
- Contact Hector for Complete Coverage of Specialty Retail Stores Throughout the United States and Canada.

NEW YORK CITY—48 WEST 22nd ST., (212) 242-1989
OREGON, WASHINGTON—2901 NORTH 2nd, SEATTLE, (206) AT 3-4226
NORTHERN CALIFORNIA—93 GOLDEN HINDE BLVD., SAN RAFAEL, (415) 479-4726
SOUTHERN CALIFORNIA—17628 NORDHOFF STREET, NORTHRIDGE, (213) 886-1670

Send for Free Current Mailway Orderform
With Latest List of Labels Available.

■ HECTOR DISTRIBUTING COMPANY
■ 48 WEST 22nd STREET, NEW YORK, N. Y. 10010

MIAMI'S NEWEST DISTRIBUTORSHIP

backed by
84 Years of Experience

CAMPUS

RECORD DISTRIBUTING, INC.

6751 N.W. 37th Court
Miami, Fla. Phone (305) 691-3140

Joe Stancione, Mgr.

NEW ENGLAND'S LARGEST RECORD DISTRIBUTOR

Eastern
Associated
RECORDS
Northeastern
Allied

360 TOLLAND
STREET
EAST HARTFORD
CONN.

AREA CODE
203
289-7431

RECORD DISTRIBUTORS

and the lines they handle

CHARLOTTE (CONT)

F. & F Enterprises
2704 Freedom Dr.
Bert Flaishman
(Westminster)

Mangold Dist. Co.
2212 W. Morehead St.
Herb Weisman—334-0866
(MGM, London, Kapp, Disneyland, Sun, Everest, 20th
C-F, Philips, Amy/Malo, Monument, Kent, Songs of
Faith, Goteway, Congress, Imperial Rampart, Tower,
Modern, Hickory, Era, Hi, Porrott)

Southern Bearings & Parts Co. Inc.
500 N. College St.
P. Evans Bostick—375-5731
(Columbia)

GREENSBORO—(919)

Southland Musical Mdse. Corp.
826 Winston St.
Louis Jarrett—BR 2-5123
(Music Minus One, Living Literature, Word, Diplomat,
Young Peoples Records, Golden Records, Audio,
Peter Pan, Living Language, Conversa-Phone)

OHIO

AKRON—(216)

Twelgren Ent. Inc.
2775 Yellow Creek Road
J. H. Macey—216 TE 6-5591
(Aqua, Balance, Bel-Mar, Black Mountain, Blue Star,
Bogan, Dash, Family Squares, Flip, Folkcraft, Folk
Dancer, Imperial, Go, Grenn, J Bor L, Kalox,
Keeno, Lloyd Shaw, Longhorn, MacGregor, Mayflower,
Old Timer, Sets In Order, Square L, Swinging Square,
Top, Pon Piper, TNT, Honor Your Partner, Artists
Life, Balkan, Belco, Bel-Mar, Big J, CEM, Country
Dance Soc., Dance Along, Donro, Fiesta, Ford, Hi
Hot, Israeli, Jewel, Kismet, Lore, Magic, MIBS, Mus-
tong, Prairie, Rainbow, Rockin' A, Ruper, Russell,
Soshay, SMC, SNR, Suny Hills, Wagon Wheel, West-
ern Jubilee, Windsor, World of Fun)

CINCINNATI—(513)

A & I Record Dist. Co.
1000 Broadway
Joe Nathan—241-7644
(Warner Bros., Reprise, Parkway, Cameo, Roulette,
Somerset, Hi Fi, VeeJay, Savoy, Pacific Jazz, Philips,
Wond, Scepter, Prestige, Challenge, Red Bird, Cru-
sader, Riviero, Jubilee, Alco, Arlen, Arvee, Auro,
Battle, Blue Cat, Bluesville, Cobot, Conversaphone,
Dejac, Diamond, Dore, Enjoy, Era, 4 Saints, Garvett,
Gee, Glover, Golden Wing, Golden World, Guyden,
Jomie, Jozzland, Josie, Joy, KC, Kent, K & M,
Marc, Montel, Moodsville, Musicnote, Nashboro, Ohio
State Bond, Old Town, New Jazz, Roost, Sar, Stereo
Fidelity, Skont, Swingsville, Tri Disc, Valiant, Won-
derland, World Artists, World Pacific, Wyncote)

Capital Records Dist. Corp.
35 E. 7th St.
Richard Bethel—721-5616
(Capitol, Angel)

Columbia Record Dist. Corp.
Carew Tower
William Kelly—241-4088
(Columbia, Harmony, Masterwork Phonos)

Decca Dist. Corp.
East 6th & Court St.
C. W. Doherty—721-4210
(Decca, Coral, Brunswick, London, Good Time Jazz,
Contemporary, Listen & Learn)

Four State Dist.
1239 Ellis St.
Robt. Anderson—681-7515
(ABC Par, Apt, Impulse, Westminster, Music Guild,
Atco, Moonglow, Vault, Way Out, Atlantic, Dejac,
Dial, Focus, Heidi, Rosemart, Stax, Volt, Triumph,
Brooklyn, Congress, DGG, Archive, Dunhill, Epic, Okeh,
4 Corners, Gilda, Happy Times, London, Cedwick,
Circle, Coliseum, Detroit, Domain, Felsted, Folk
Sing, Garpox, Group Hi, London American, Louis,
Medway, MOC, Palomar, Parrott, Pen, Press, Seville,
Siana, Shell, SPQR, Tribe, Watch, Mainstream, Time,
MGM, Metro, One-der-ful, Mar-v-lus, Philles, Sims,
Story Time, Sue, Eastern, Symbol, Tower, 20th CF,
Verve, Wild Deuce)

Hit Record Dist. Co.
659 E. 6th St.
Is. Nathan—241-2887
(United Artists, Vanguard, Command, Everest, Cana-
dian American, Duke, Peacock, BacBeat, Sure, Shot,
World, Hilltop, Tom Lehrer, Golden, Original
Sounds, Grand Award, Crescendo, Colpix, Dimension,
Callo, Esoteric, Counter Point, Folkways, Status, Regina,
Ascot, DCP, Veep, Young People's, Living
Language)

King Records Inc.
1540 Brewster Ave.
Syd Nathan—751-2211
(King, Bethlehem, Audio Lab, Federal, Deluxe, Gem,
Queen)

Supreme Dist. Co.
1000 Broadway
Al Klayman—421-0747
(Mercury, Smash, Monument, Bluenote, Limelight,
Soundstage, Hickory, Starday, Sing, Skylite, Songs of
Faith, Dimension, Amy, Mala, Fantasy, Fontana,
Heart-Warming, Goloxy, Chort, Mercury, Wing, Blue
Rock, Cumberland, Caedman, Fiesta, Musicor)

(Continued on next page)

FLORIDA'S MOST AGGRESSIVE



Topps

RECORD DIST. CO., INC.
Babe Elias
PRESIDENT
2222 N.W. 6TH AVE.
MIAMI, FLORIDA
FR 4-8166

**"TOPPS for Sales
and Promotion"**

**GROWING
EACH DAY**

Complete coverage of Florida

NOT THE BIGGEST
BUT ONE OF THE BEST
In The

NEW YORK

Market

STANLEY-LEWIS

Record Dist. Co.
534 W. 58th St.
New York, N. Y.
CO 5-7955

Many Thanks

Floyd Cramer



LATEST ALBUM



LSP/LPM-3405

RCA VICTOR
The most trusted name in sound

RECORD DISTRIBUTORS

AND THE LINES THEY HANDLE

CLEVELAND—(216)

Buskey Natl. Sales Corp.
6313 St. Clair Ave.
Harvey Korman—431-1155
(Amer. Artist, Armour, Canary, Capo, Chort, Chevell, Circa, Clark, Curley Q, Dopper, Down Home, Daraleno, Farest, JCP, Jo Mor, Longhorn, Nugget, Prism, Progress, Post, Peach, Pocono, ReVon, Rice, Token, Tim, Troin, Spon, Sound, Sound Spectrum, Songs of Faith, Sound of Nashville, Vulcan, Wolff)

Capitol Records Dist. Corp.
2800 Euclid Ave.
Jim Johnson—861-9187
(Capitol, Angel, also: Copital Phonographs, Duetane Needles & Acc.)

Cleve-Disc. Dist. Inc.
1550 East 33rd St.
Godfrey H. Dickey—391-1320
(ABC, Warner, Reprise, Atco, Epic, DGG/Archive, Westminster, London Group, Impulse, Original Sound, Colpix, 20th CF, Okeh, Dimension, Tower, Crescendo, Monument, Congress, Four Corners, Constellation, Fiesta, Tongerine, Music Guild)

Concord-Bernart Dist. Co. Inc.
620 Frankfort Ave.
Arthur Freeman—621-7274
(Auro, Chattahoochie, Crackerjack, Crusader, Dance-Along, Dooto, Dyno, Foro, Good Time Jazz, Gospel, Guyden, Holl, Jomie, Montel, Motown, Pacific Jazz, Phills, Regent, Riviero, Savoy, Sharp, Specialty, Sue, Teardrop, U.S.A., World Pacific, Arctic, Argo, Ar-rakow, Assoc. Artists, Blue Note, Checker, Chess, Clack, Command, Contemporary, Current, DCP, D-Town, Destination, Disneyland, Downey, Eastern Era, Gardy, Grand Award, Heortwarming, J&S, Jewel, Juniar, Londo, Monogram, Paula, Rampart, Sar, Stella, Sum, TCF-Family, Tolly, Ultimo, VIP, Veep, Visto, Wore)

Decca Dist. Corp.
746 W. Superior Ave.
Bill Green—621-9770
(Decco, Coral, Brunswick, London, Richmond, Telefunken, Listen & Learn, Vocalion)

Grossman Music Corp.
740 Bolivar Road
Al Diamond—TO 1-3900
(Music Minus One, Golden Crest, Grand Award)

Mainline
1260 East 38th St.
Ed Rosenblatt—EX 1-1800
(Kapp, MGM, Verve, Laurie, Amy, Malo, Duke, Peacock, Elektra, Chess, Checker, A&M, Almo, Gordy, Tamola, Motown, Red Bird, Nonesuch, K&H, Bell, Big Hill, Argo, Fraternity, Autumn, Blue Cot, Golden World, Aurora, Challenge, Bang, Sunglow, Sahara, Voliant, Mike, Rust, Pan, Musicor, King, Federal, Deluxe)

Seaway Dist. Corp. Inc.
3142 Prospect
Som Davis—EX 1-7300
(Atlantic, Audio Fidelity, Dot, Disneyland, Eurotone, Hamilton, Jay Joy, Josie, Jubilee, Old Town, Porlioment, Scepter, Stox, Swon, Time, Wand, World Artists, Audio Spectrum, Blue Rock, B. T. Puppy, Dial, Everest, Gross, Hickory, Moce, Mainstream, Monitor, Pickwick, Socred, Sims, Word)

OKLAHOMA

OKLAHOMA CITY—(405)
B & K Dist. Co.
129 N.W. 23rd St.
Bill Burton—JA 5-7509
(MGM, Liberty, ABC, Porkway, Comeo, Reprise, Roulette, Chancellor, Swan, Duke, Delfi, Dolton, Blost, Jomie, Diamond, Commond, Grand Award, Kopp, Living Language, Phillies, Sue, Peacock, Old Town, Atco, Volt, Impulse, Disneyland, Buena Visto, Golden, Choreo, Dunes, Big Top, Malo, Amy, Dimension, Monogram, Guyden, Bock Beat.)

Dulaney's
100 N.W. 44th St.
Clyde C. Boll—JA 8-0511
(RCA Victor, RCA Comden, Fraternity, Colpix, Atlantic.)

Miller-Jackson Co.
111 East California
Bill Hill—CE 5-1486
(Columbia, Epic, Okeh.)

Oklahoma Record & Supply Co.
18 N.E. 48th St.
P.O. Box 3313
R. C. Morquiss—JA 5-3325
(Mercury, Warner Bros., London, Audio Fidelity, Somerset, Stereo Fidelity, Smash, London American Group, Sun, Richmond, Monument, Jubilee, 20th CF, Wing.)

Sonart Dist. Corp.
133 N.W. 23rd St.
Peggy Sullivan—JA 4-3993
(Apollo, Artio, Arvee, Blue Note, Caedmon, Con Amer, Caprice, Cimorron, Closs, Concert Disc, Congress, Crestview, Composers Recording Society, Conversophone, Coco, Delden, Distinguished, Recordings, Domain, Dyer Bennet, Elektra, Enith, Everest, Faber, Folkways, Fraternity, Headline, Hickory, Hifi, Josie, Kiddie Korner, Laurie, Legrand, Morsh, Minaret, MMO, Norman, Prestige, Project, Redcoast, Riverside, Starday, Stereoddities, Tri Disc, Troy, Vanguard, World Pacific, Zen.)

OREGON

PORTLAND—(503)
North Pacific Supply Co. Inc.
2950 N.W. 29th Ave.
Harry Salvus—228-9576
(RCA Victor, RCA Comden.)

PENNSYLVANIA

BETHLEHEM—(215)
Rove Dist. Co.
938 Sullivan St.
Joe Timmer—868-9315
(Apon, B&F, Dola, Rex, Glo, Joy Joy, Chicago, Dumo, Rove, Hazom, Request, Universe, Edelweiss, Polkaland, R.E.F.)

BROOMALL—(215)
Lesco Dist.
2205 Mary Lane
Edward D. Cohn—EL 6-1887
(Conary Bird, Cetero, Dance Along, Datus, Diplomat, Eterno, Experience, Anonyme, Guest Star, Hot Rod, Key, Lesco, Lyrichord, Peter Pon, Plozo, Porokeet, Rainbow, Rosemont, Tone King, Vox.)

HARRISBURG—(717)
D & H Dist. Co. Inc.
2525 N. 7th St.
David Press—236-8003
(RCA Victor, RCA Camden, Mercury, Wing, Ric, Cumberland, Joy Joy, Rove, Buch, Stello, Goteway, Golden, Metro, Sacred, Summit, Sword, Time, Word.)

PHILADELPHIA—(215)
A & L Dist. Inc.
1811 Fairmont Ave.
Al Melnick—PO 5-4300
(Arc, Amy, Mola, After Hours, Alector, Arvee, Bell, Big Hill, Bonded, Broadside, Conversophone, Colonial, Deorbom Desto, Dimension, Dynovox, Elektro, Entertainment, Fantasy, Folkways, Galaxy, Glad Homp, Golden Crest, Gregorian Institute, Headline, Helios, Joy, KFM, Marvel, Moxx, Monitor, Mr. Maestro, Music Minus One, Murril, Nina, Nonesuch, Request, Regina, Rittenhouse, Richard Dyer Bennet, Rivoli, Select, Riot, Simon Sez, Spoken Arts, Stordard, Summit, Tikvo, Tradition, Villogge Gate. Also Accessories, Zebro.)

Alsom Distrib.
1811 Fairmont Ave.
PO 5-4121
(Audio Fidelity, Aravel, Battle, Constellation, Documentary LP #3, Enjoy, Exello, In, Jazzland, M.B.S., Mutual, Nashboro, Offbeat, Piedmont, Riverside, Storytime, Sylvia, Washington, Wonderland.)

Capitol Records Dist. Inc.
2629 N. 15th St.
C. A. Dolak—BA 9-1550
(Capitol, Angel.)

Chips Dist. Co.
808 N. Broad St.
Al Rosenthal—PO 9-5000
(Comeo, Congress, Disneyland, Era, Fraternity, Gateway, Motown, Parkway, Ric, Sor, Sue, Swon, Tallie, Wyncette, Veejey, Vista, Ario, Blue Rock, Carnival, Cheltenham, Diamond, Dore, Dunhill, Eastern, Fome, Four Corners, Goldwax, Gordy, Interphon, JJC, Lown, Parliament, Rotote, Soul, Southern Sound, Symbol, TCF, Tamla, VIP, Wild Deuce.)

Columbia Record Dist.
4 Penn Center Plaza
Ed Masterson—LO 8-4445
(Columbia, Harmony.)

Decco Dist. Corp.
46-50 N. 6th St.
W. J. Donovan—WA 2-5659
(Decco, Coral, Brunswick, Vocalion, Listen & Learn.)

Soul Lampert, Inc.
1242 W. Girard Ave.
Saul Lampert—CE 2-4269
(Lenoc, Aikens, Lofoyette, Banbox, Con Amer, Diamond, Dictation, Disc, Duke, Glodus, Joy, DC, Tahoe, Palomar, Pless, Moc, Keith, Moscot, Musicnote, One-derful, Peacock, Prestige, New Jazz, Moodsville, Tru Sound, Swingsville, Carib Corp., Golden Wing, Jomie, Guyden, Hull.)

Lesco Dist.
17 S. 21st St.
Edw. D. Cahn—LO 3-6127
(VPC, Archive, Deutsche Grammophon, Lyrichord, Eterno, Experience, Anonyme, Crown, Vernan, Diplomat, Guest Star, Peter Pon, Ambassador, Conary Bird, Porokeet, Hot Rod 45's, Sport Car 45's, Lesco, Rosemont, Cetra, Pathways of Sound, Stinson, Universe, Arhoolie, Folk Lyric.)

Mainline Dist. Inc.
2450-52 N. Broad St.
Borrry Golder—BA 8-1375
(Tomla, Gordy, Noshboro, Exello, Scepter, Distinguished, Lindo, Hob, Starday, Dooto, Crown, Strond, SPQR, Choirman, Gorpax, SCA.)

Marnel Dist. Co. Inc.
2512 N. Broad St.
Marshall Verbit—BA 6-1222
(Atlantic, Ascot, Bang, Blue Note, Coedmon, Colpix, Concert Disc, Counterpoint, Dana, Dial, Dooto, Duke, Peacock, Duo Disc, D-Town, End, Esoteric, Everest, Fiesta, Grcophone, Hi Fi, Jubilee, Josie, Lourie, Legrand, Life, Liberty, Lost Nite, Mainstream, Music Tabes, Pacific Jazz, Prestige, Roost, Roulette, Rust, Savoy, Regent, Gospel, Specialty, Starday, Noshville, Status, Stereoddities, Stax, Sun, Time, Tom Lehrer, Tower, 20th CF, Tica, United Artists, Voliant, Vanguard, World Pacific.)

PR Dist. Co.
511 N. Broad St.
Jerome Armour—WA 5-7278
(Boone, Hanno Barbero, Jay Jay, Pasa, Quallo.)

Quaker City Rec. Dist. Inc.
821 No. Broad St.
Al Kelly—WA 5-1413
(Amer. Artists, Arrowak, Autumn, Bally, Bongor, Blost, Cragg, Camay, Cee Jam, Charger, Chort, Donna Delfi, Doc, Erotica, Fabor, Foro, Fax, Ford, Gallio, Gen'l. Amer., Gozo, Grand, Hickory, Hull, Ivonhoe, Jewel, Kent, Kiddie Korner, Linda, Lola, Magnum, Mighty, Money, Music World, Polydor, Princess, Pulse, Rampart, Ring, Sounds of Nashville, Sutton, Tamord, Thelma, Tribute, Try, World Artists, King, Deluxe, Federal, Bethlehem.)

David Rosen
835 N. Broad St.
Harry Rosen—CE 2-6905
(ABC Pae, Argo, Challenge, Chess & Checker, Command, Fleetwood, Grand Award, Impulse, Kapp, Modern, Music Guild, Musicor, Red Bird, Soma, Int'l. Ltd., Monument, Reprise, Sound Stage 7, Sure, Tangerine, Warner Brothers, Westminster, Apt, Audio Spectrum, Bonner, Big Top, DCP, Golden, Hill Top, Imperiol, Living Languoge.)

Raymond Rosen & Co. Inc.
51st. & Parkside Ave.
Poul Knowles—TR 8-2200
(RCA Victor, RCA Comden, London, MGM, Verve, Metro, RCA Victrola, Eurotone.)

Universal Record Dist.
919 N. Broad St.
Len. Rokliff—CE 2-3333
(Atco, A&M, Con Amer, Coed, Contemporary, Delfi, Jomie, Guyden, Old Town, Original Sound, Philles, Pacific Jozz, Scepter, Wond, Epic, Okeh, Crescendo, Dot.)

PITTSBURGH—(412)
Capitol Records Dist. Co.
110 St. Joseph St.
Dennis Letzler—431-5803
(Capitol, Angel.)

Columbia Record Dist.
Porter Bldg.
James K. Winston—261-2844
(Columbia, Harmony, Epic, Okeh.)

East Coast Dist.
633 Liberty Ave.
Nick Lomokin—AT 1-6344
(Dooto, K&H, Niki, Audiotope, Switch Craft, Akgos.)

Eckhardt & Co.
347 Bouquet St.
James K. Winston—683-6444
(Columbia, Epic, Harmony, Okeh.)

Empire Dist. Co.
4610 Liberty Ave.
S. R. Cantermon—682-8437
(Lines not available on this time.)

(Continued on next page)

Not Only Is the Finest in Independent Distributing a Tradition With

Dumont Record Distributing Corp.

BUT WE ENJOY WHAT WE ARE DOING!!!

DUMONT RECORD DIST. CORP. 1040 Tremont St., Boston, Mass. (617) HI 2-0800

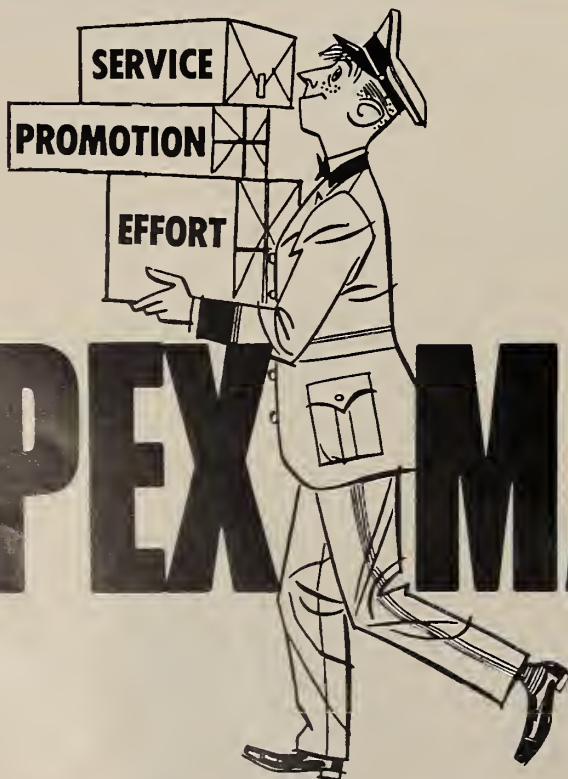

APEX MARTIN

351 WASHINGTON ST., NEWARK, N.J. 07102 (201) 623-7231 • JERRY COHEN, Gen. Mgr. • JOE MARTIN, Pres.

WHAT'S NEW PUSSYCAT?



THE NO. 1 MOST PROMISING
MALE VOCALIST
IN THE CASH BOX DJ POLL

TOM JONES

A SPECIAL THANKS TO
DECCA - ENGLAND . . .
LONDON - UNITED STATES . . .
& THE ENTIRE STAFF OF
THE ED SULLIVAN SHOW.



PERSONAL MGT.

GORDON MILLS
LLOYD GREENFIELD

PRESS

ADE KAHN
CONNIE DENAVE

AGENCY

ACUFF-ROSE
ARTISTS CORPORATION

**CONTACT: AL MELNICK FOR
THE MOST AGGRESSIVE
INDEPENDENT DISTRIBUTION
IN PENNSYLVANIA, NEW
JERSEY AND DELAWARE.**



A&L

DISTRIBUTORS, INC.

1811 Fairmount Ave.
Philadelphia, Pa.
(215) POplar 5-4300

THE BEST IN SALES

**THE BEST IN PROMOTION:
PROMOTION DIRECTORS
HARRY PHINQUE
BARRY ABRAMS**

**THE BEST IN SERVICE:
SERVICE MGR.
JACK VILLANUEVA**

ALSAM

DISTRIBUTORS, INC.

1811 Fairmount Ave.
Philadelphia, Pa.
(215) POplar 5-4121
Contact: Al Melnick

OUR BEST RECOMMENDATION IS OUR SATISFIED MANUFACTURERS

HARTFORD'S OLDEST INDEPENDENT RECORD DISTRIBUTOR
SERVING

Conn.—Western Mass.—Upstate N.Y.—Vermont

TRY US and SEE
WHY WE ARE NO. 1

PROMOTION • SALES • SERVICE

SEABOARD DISTRIBUTORS, INC.

AN AFFILIATE OF ROSKIN DISTRIBUTORS INC.

275 PARK AVE. Phone 203-289-9361 East Hartford, Conn.

Marv Ginsburg—Sales Manager / Jerry Greenberg—Promotion

IN UPPER NEW YORK IT'S GERBER DISTRIBUTING CO., INC.

FOR

WARNER BROS. . . . UNITED ARTISTS COMMAND REPRISE
VANGUARD MGM VERVE AUDIO FIDELITY
AND MANY OTHER TOP LABELS

GERBER DISTRIBUTING CO., INC.

313 Herald Place, Syracuse, N. Y. 13201
BILL GERBER, PRES. (315) 471-2118



STICK WITH A WINNER!

OUR 7th BIG YEAR OF
AGGRESSIVE PROMOTION & SALES

WENDY DISTRIBUTORS

37 Williams St., Newark, N.J., (201) MA 3-5845, JERRY WINSTON

RECORD DISTRIBUTORS

and the lines they handle

(PITTSBURGH, CONT'D.)

Fenway Record Corp.
1601 5th Ave.
Herbert S. Cohen—391-3973

(Amy, Argo, Atlantic, Blue Note, Checker, Chess, Chattanooga, Congress, Constellation, Crusader, Delfi, Diamond, Dimension, Everest, Faber, Golden Crest, Golden World, Gordy, Jay Jay, Kapp, Mala, Motown, Musicnote, Old Town, Red Bird, Roulette, Scepter, Tamla, UA, Wand, World Artists, 20th CF, cenda, Dial, Donna, Dore, Duo Disc, Dyno, End, Ascot, Autumn, Blue Cat, Carnival, Charger, Cres-Fenway, Fiesta, Four Corners, Gee, General American, Glover, Golden Wing, Gone, Hi, Hickory, Hob, Hull, Laugh Time, Lesage, London, Mar V Lus, Maxx, Monument, New Time, NPC, Onerful, Parrott, Paula, Rampart, Ricky, Rik, Riviera, Roost, Sims, Soma, Soul, Stax, Stereodities, Tico, USA, Witch, Banner, Marc.)

Hamburg Bros. Inc.
213 Galvestan Ave.
Mart J. Locker—322-2400

(RCA Victor, Camden, Victrola, Groove, Liberty, Dalton, Colpix, Coed, ABC, A&M, Alma, Apt, Bach Guild, Dana, Dunhill, Eurotone, Fraternity, Golden, Hanna Barbara, Impulse, Joy, Jubilee, Josie, Living Language, Monument, Pickwick, Savoy, Select, Starday, Tangerine, Tower, Vanguard, Westminster, Young People's Records.)

Standard Dist. Co.
1601 5th Ave.
Lee Levine—391-3973

(Warner Bros., Cameo Parkway, Vee Jay, Atco, Laurie, Command, Era, Challenge, Reprise, Imperial, Kent, Charter, DCP, Flip, Gateway, Grand Award, Hilltop, Loma, Modern, Moonglow, Original Sound, Phyllis, Swan, Valiant, Wyncote.)

RHODE ISLAND

PROVIDENCE—(401)
Eddy & Co., Inc.
43 Hospital St.
Haig Yaghoobian—GA 1-2045
(RCA Victor, RCA Camden.)

TENNESSEE

KNOXVILLE—(615)
McClung Appliances
310 Georgia St.
Albert W. Smith—524-1811
(RCA Victor, RCA Camden, Peter Pan, Pickwick, Hilltop, Heartwarming, Scripture.)

MEMPHIS—(901)
Capital Records Dist. Corp.
1792 Latham St.
Roger Berkley—WH 8-6713
(Capitol, Angel.)

Best Wishes From HITSVILLE Inc.

Tamla
Motown
Gordy
Melody
Soul
VIP

3009 W. Pico Blvd.
Los Angeles 6, Calif.

Ralph Kaffel Gil Bogos
President Gen. Mgr. &
Promo Director

Columbia Mid-South
37 E. Carolina Ave.
Tam Craft—525-7741
(Columbia, Epic, Okeh.)

McDonald Bros. Co. Inc.
994 S. Bellevue Blvd.
Chas. Smith—948-2771

(RCA Victor, Mercury, Smash, Colpix, Monument, Hickory.)

Music Sales Co.
1117 Union Ave.
Leon McLemore—276-1776/77

(ABC Par, Command, Impulse, Tamla, Motown, Scepter, Chess, Checker, Argo, Stax, Roulette, Hi, Phyllis, Son, Phillips, Jamie, Starday, Swan, Golden, Apt, Tangerine, Westminster, Music Guild, Grand Award, Amy, Atco, Atlantic, Big Hill, Big Top, Constellation, Dial, Gordy, Hob, Joy, Kenwood, Laurie, Mala, Mar V Lus, Michelle, Moc, Moonglow, Nashville, Nashboro, Old Town, Onerful, Parrott, Project, Riviera, Resmart, Sar, Soul, Specialty, Squire, Tribe, USA, Volt, Wand, Zone.)

Record Sales Corp.
311 Exchange Ave.
Stanley Terry—526-7361

(Ascot, Autumn, Backbeat, Blue Cat, Congress, Crescendo, Crown, DCP, Diamond Dimension, Double L, Duke, Eastern, Era, Fame, Goldwax, Hilltop, Imperial, Interphone, Jewel, Kent, Liberty, Living Language, Money, Original Sound, Paula, Peacock, Red Bird, Reprise, Song Bird, Sue, Tally, Teardrop, Tollie, United Artists, Vee Jay, Warner Bros., World Artists, Young Peoples.)

TEXAS

DALLAS—(214)
Adelta Co.
1914 Cedar Springs
David Eisenlahr—RI 1-3151
(RCA Victor, RCA Camden, Disneyland, Buena Vista.)

Best Record Dist. Co.
1327 Chemical St.
Kerry Charlton—ME 1-0660

(Challenge, Cricket, Crown, Design, Disneyland, Dooto, Grand Prix, Hickory, Hi Fi, Joy, Rendevouz, Starday, Valiant, Vista, Warner Bros., Wonderland.)

Big State Dist. Co.
1337 Chemical St.
Bill Emerson—ME 1-1110

(ABC Par, Atco, Atlantic, Challenge, Coed, Colpix, Delfi, Dore, Ember, Fraternity, Imperial, Jamie, Kapp, Laurie, London, Mala, Nashboro, Parkway, Richmond, 20th CF, Vee Jay, Warwick, Argo, Autumn, Bluenote, Backbeat, Cameo, Celeste, Crusader, Checker, Chess, Congress, Duke, Era, Faber, Faro, Fantasy, Four Corners, Falew, Golden Crest, Golden World, Gateway, Hall, Sure Shot, Guyden, Jay, Kent, Legrand, Tribe, Musicor, Monument, Old Town, One Der Ful, Loul, Original Sound, Peacock, Red Bird, Blue Cat, Prestige, Tolley, Big Hill, Bell, Sue, Sun, Swan, World Artists, Rampart, Brown Field, Capri, Charger, Command, Constellation, Destination, Palomar, Dial, Diamond, Dolton, Domain, D-Town, Dynovox, Excello, Fame, Moonglow, Galaxy, Gold Wax, Gordy, Hilltop, Hi, Impulse, Interphon, Jubilee, Oldies, L&K, Longhorn, Mar V Lus, Melody, Maxx, Michele, Moc, Motown, Tamala, Tangerine, Volt, Watch.)

Calmar Dist. Co.
2404 Farrington
Bill Caldwell—ME 1-3820

(Mercury, Smash, Warner Bros., Challenge, Valiant, Audio Fidelity, Reprise, Hickory, Starday, Stereo Fidelity, Somerset, Time, Strut, Curley Q.)

Capital Record Dist.
5105 Lakawana Drive
Marvin Beisel DSM—ME 7-1890
(Capitol, Angel.)

Columbia Record Dist.
8808 Empress Row
Dan Sullivan—ME 1-5680
(Columbia, Epic, Okeh.)

Decca Dist. Co.
139 Cale St.
C. E. McNabb—RI 2-3739

(Decca, Coral, Brunswick, Listen & Learn, Elektra, Contemporary, Coedmon, Nonesuch.)

Delta Dist. Co.
5652 Daniels Ave.
E. N. Bernet—EM 1-7717

(American Artist, Billups, Chart, Canary, Capa, Dapper, Down Home, Great, JCP, Levee, Memphis, Nugget, Peach, Pit, Ponzer, Post, Sandeb, Salem, Sound, Tim Token, Topic, Train, Vulcan, Wheeling.)

(Continued on next page)

Happy 23rd from AL SHERMAN RECORD SALES CO.

2818 Pico Blvd.
Los Angeles, Calif.
RE 1-9474



HARRY FINFER and HERB GORDON
—New Distributorship—

We offer 100% cooperation to our lines.
Could use a few more lines.

QUAKER CITY RECORD DIST. CO.
Philadelphia, Pa.
821 N. Broad St. (215) CE 6-8406

The Voice and Music of "Gentleman Jim"

Favorites Throughout The World

MOST PROGRAMMED COUNTRY ALBUM — 1965

#2 "BEST OF JIM REEVES"

#6 "JIM REEVES"

MOST PROGRAMMED COUNTRY MALE VOCALIST — 1965

#2 JIM REEVES

MOST PROGRAMMED COUNTRY SINGLE — 1965

#6 "I GUESS I'M CRAZY" — JIM REEVES

#7 "THIS IS IT" — JIM REEVES



RCA VICTOR

 The most trusted name in sound 

JIM REEVES ENTERPRISES

P.O. BOX 128

Madison, Tennessee 37115

Phone: 895-5484

RECORD DISTRIBUTORS

AND THE LINES THEY HANDLE

Lindy Dist.
427 W. San Antonio
Lindy B. Cash—532-1434
(Ambassador, Cobra, Cricket, Del Fi, Discos, Columbia, Discas, Corona, Eco, El Zarape, Goldsboro, Jax, Jima, Musart, Mustang, Linjo, Peerless, Premier, Sargard. Also: Walco Needles, Lyric Racks & Cases)

Dot Dist. Corp.
1347 Chemical
John P. Vesco—ME 1-0630
(Dot, Hamilton, Planetary.)

EL PASO—(915)

M. B. Krupp Dist. Inc.
311 S. Santa Fe St.
M. B. Krupp—KE 2-4961
(ABC, A&M, Allstar, Almo, Almont, Amy, Argo, Arlen, Audio Fidelity, Autumn, Back Beat, B. T. Puppy, Cameo, Canadian American, Canjo, Challenge, Chart, Chattahoochee, Checker, Chess, Colpix, Constellation, Crazy Town, Crown, Crusader, Coronado, "D", Delmar, De Ville, Diamond, Dimension, Dootone, Dore, Duke, Duncan, Ember, End, Era, Everest, Exeter, Fabor, Fame, Fantasy, Faro, Fernwood, Flip, Fraternity, Frogdeath, Galaxy, Garrett, Golden Ring, Golden Wing, Goldenworld, Gardy, Happy, Herald, Hickory, Hi Fi, Hilltop, International City, Jamie, Jasie, Jax, Joy, Jubilee, K. T., Kent, L. K., Laurie, Legrand, Longhorn, Mala, May, Melody, Michelle, Minit, Monogram, Montel, Motown, Matown/Workshop Series, Mutual, Nashville, Newtown, Norco, Oldies, Original Sound, Parkway, Petal, Philles, Project, Quill, Red Bird, Remar, Riveria, Roulette, Rust, Scepter, Serock, Sims, Sama, Sanja, Starday, Sue, Scepter, Sun, Symbol, Talent Scout, Tally, Tamla, Tear Drop, Tallie, 20th Fox, United Modern, Vee Jay, Wand, Whirlybird, World Artist, Wyncote, Yucca.
Spanish Labels: Aragan, Bego, Bronco, Colonial, Coast, Columbia, Corana, Dela, Del Valle, DLV, Larga, Vida, Falcon, Fuentes, Gapoca, Grande, Ideal, Lira, Maya, Monterrey, Music, Musart, Napal, Norteno, Orfean, Oro, Peerless, Popular, Sombrero, Sun-glow, Teardrop, El Zarape)

Sunland Supply Co. Inc.
2227 Texas Ave.
Richard Kalina—533-5901
(Allegro, Artia, Audio Book, Bethlehem, Bruno, Coed-mon, Cricket, Cumberland, Deluxe, Felsted, Federal, Folkways, Hi, Impulse, King, King Group, Living Language, Children's Record Guild, London, London Group, Monitor, Monument, Musart, Original Sound, Parliament, Peter Pan, Richmond, Shasta, Specialty, Telefunken, Tampa, Urania, Vanguard, Vox, Young Peoples Records, Concert Disc, Golden Crest)

HOUSTON—(713)

H. W. Daily, Inc.
314 East 11th
Bud & Don Daily—UN 1-6868
(A&M, ABC Paramount, Apt, Audio Spectrum, Aurora, Amy, B. T. Puppy, Betty, Bonanza, Ball, Big Hill, Brag, Bang, Challenge, Chattahoochee, Carnival, Canadian American, Charger, Command, Champion, Congress, Country Caper, Constellation, Crescendo, Crusader, Cobra, Coliseum, Canaan, Conversaphone, Cinderella, Cue, Daryl, Dunhill, D, Dart, Diamond, Dictation Disc, Donna, Delfi, End, Excello, Era, Four Corners, Fame, Fantasy, F M, Fraternity, F & G, Gone, Goldring, Group, Goldwax, Garrett, Galaxy, Gee, Gregmark, Grass, Grand Award, Gateway, Hickory, Hill Top, Interphan, Imperial, Impulse, Jasie, Jubilee, Jox, Kapp, London, London Argo, LeGrande, Laurie, Le Sage, Monogram, Mainstream, Mar-V-Lus, Mala, Maney, Musicor, Minit, Music Guild, Mangum, Nash-bar, New World, Old Town, Original Sound, Oldies, Pastel, Parkway, Philles, Palomar, Peoria, Port, Prestige, Ruff, Rust, Rotate, Ric, Raulette, Roost, Regina, Richmond, Simpson, Spar, Sarge, Sunglow, Smokey, Squire, Status, Sacred, Swinging, Trusound, Troy, 20th Century Fox, TNT, Tico, Trio Disc, Tangerine, Tally, Tallie, Vanguard, Vee Jay, World Artist, Westminster, Word, Wyncote)

Dot Records Inc.
1400 Cullen
Jim C. Wardlow—CA 2-2363
(Dat, Crescendo, Pacific Jazz, World Pacific)

United Record Dist. Co.
1613 St. Emanuel
Steve Poncio—CA 8-8151
(Atco, Atlantic, Astro, Argo, Ascot, AFO, American-London, Audio-Fidelity, Backbeat, Bellaire, Bluenote, Best, Carsan, Colpix, Blue Rock, Autumn, Pricewise, Rampart, Specialty, Tower, Triumph, Volt, Chess, Checker, Capitol, Crown, Children Record Guild, D.C.P., Duke, Dooto, Ember, Enjoy, Fury, Focus, Fabor, Folsking, Gordy, Group, Carfax, Giggles, Gospel, Guyden, Hi, Herald, Hob, Joy, Jin, Jamie, Kent, La Louisianne, Living Language, Mace, Monument, Modern, Motown, Moonglow, Parrot, Pla-boy, Peacock, Press, Project, Redbird, Regent, Reprise, S.P.Q.R., Seville, Sound Stage 7, Sue, Sun, Stax, Swan, Sims, Sar, Simco, Sharp, Savoy, Symbol, Scepter, Spade, Swallow, Tuff, Tamla, Triumph, Teardrop, Tollie, United Artists, Wand, Word, Warner Bros., Workshop Jazz, Vault, Valiant, U.S.A., Young People Records)

J. A. Wash & Co.
4301 Golf Freeway
P.O. Box 4281
W. L. Whitehead—CA 3-4281
(RCA Victor, RCA Camden, Groove, Victrola)

SAN ANTONIO—(512)

Perry Shankle Co.
1801 S. Flores St.
J. J. Schneider—CA 3-1801
(RCA Victor, RCA Camden, RCA Mexicana, Liberty, Dalton, Disneyland, Lyric, Fidelitone, Design, Grand Prix, Hilltop)

Tanner 'N Texas
1422 W. Poplar
Chas. Cole—PE 2-8072
(Golden, Falcon, TNT, Ward, Simon Says)

SAN BENITO—(512)

Rio Grande Music Co.
P. O. Box 861
Paco Betancourt—EX 9-1471
(Ideal, Alfa, Columbia, Corona, Colonial, Coast, Cima, Del Valle, Dela, Gabe, Lira, Bronco, Cobra, Homenaie, Jax, Sunglow, Valmon, Narco, Zarape, Napal, Norteno, Oro, Popular, Rio, Rosina, Sombrero, Teardrop, Torera, Bega, Falcon, RCA Victor, Musart, Peerless)

UTAH

SALT LAKE CITY—(801)

Cordova's Import & Distrib
543 West 3rd N.
Carl C. Cordova—355-0642
(Falcon, Bronco, Del Valle, Columbia, Mexican, Peerless, Musart, Colonial, Napal, Norteno, Lira, Sombrero, Orfean, Eco, Bego, De Marca, Disco, Grande, El Zarape, Pan Am, Sunglow)

Great Western Record Dist. Corp.
1544 S. Redwood Road
Ray Peterson—486-0735
(United Artists, MGM, Cub, Chroca, Ava, Colpix, Jubilee, Disneyland, Laurie, Rust, Legrand, Swan, Cim-Sims, Fabor, A&M, Era, Todd)

Huish Dist. Co.
2525 S. 8th St.—P.O. Box 15038
Ross J. Davis—486-7611
(RCA Victor, RCA Camden, Philips, Vanguard, Cameo-Parkway, Murlil, Assoc. Wyncote)

VIRGINIA

RICHMOND—(703)

Allen Dist. Co. Inc.
3409 West Leigh St.
Milton Sinsheimer—EL 5-7896
(London, Richmond, 2 Phase, Argo, Classic, Telefunken, Sun, Original Sound, Colpix, 20th C-F, Design, Crown, Somerset, Borderline, World Artists, Fraternity, Hi, Savoy, Caedmon, Folkway, Gospel, Peter Pan, King, Federal, Deluxe, Bethlehem)

Goldberg-Tiller Corp.
959 Meyers St.
Gordon Moncure—EL 8-2321
(Columbia, Epic, Okeh)

WASHINGTON

SEATTLE—(206)

Capitol Record Dist. Corp.
1920 Terry Avenue
Margo Sires—MA 3-1920
(Capitol, Angel)

C & C Dist. Co.
1000 1st So.
Lou Laventhal—MU 2-7188
(Atlantic, Dot, Jubilee, Liberty, MGM, Roulette, Verve)

Craig Corp.
1021 East Pine St.
James Fuscald—EA 4-3939
(Columbia, Epic, Apollo, Everest, Ember, Era, Fabor, Fraternity, Gardena, Herald, Original Sound, Pacific, Jazz, Philles, Prestige, Request, Scepter, Simon Says, Sims, Specialty, Wand, World Pacific, Jerden, Congress, FM)

Decca Dist. Corp.
3131 Western Avenue
Bob Gardner—A 4-8060
(Decca, Carol, Brunswick, Listen & Learn)

(Continued on next page)

WE REPRESENT:

A&M	Epic	RSVP
Autumn	Fantasy	St. Lawrence
Chart	Galaxy	Satellite
Chattahoochee	Golden World	Simon Says
Constellation	Hickory	Soma
Disneyland	Jerden	Sound of Nashville
Elektra	Mainstream	Southern (Sound)
	Nonesuch	Tradition
	Okeh	Vee-Jay
	Pan	White Whale

Two promotion men in Chicago.

RON JONGSMA • CHARLES "DEEK" ATKINS

We represent Epic/Okeh Records throughout Southern Ohio (Cincinnati, Columbus, Dayton), and Southern Indiana. Julie Godsey handles promotion and Jim Berning is our sales representative. Both reside in the Cincinnati Area and are experienced record people.

Summit Dist. welcomes the challenge of concentrating on your product in Illinois, Indiana or Ohio.

Jack White—Seymour Greenspan

Illinois & Indiana:

SUMMIT DIST., INC.

1345 Diversey Parkway
Chicago, Illinois 60614
(312) 248-3621

Ohio:

SUMMIT DIST., INC.

211 East 4th Street
Cincinnati, Ohio 45202
(513) 241-6361

HAPPY ANNIVERSARY

CASH BOX

NATIONAL HIT BUILDERS

- ☆ TOP SALES
- ☆ TOP PROMOTION
- ☆ TOP SERVICE

ERNIE LEANER

Promo Men: LEROY PHILLIPS—ART SMITH—MIKE ALLEN

UNITED RECORD DISTRIBUTORS, INC.

1827 South Michigan Ave., Chicago 16, Ill.
(All Phones: CAIumet 5-6605)

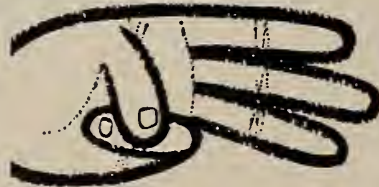

We Are From Detroit
We Are Now 3 Years Old
We Are Now Representing:
A & M • AMY-MALA-BELL
TAMLA • GORDY • V.I.P. • VALIANT
MONUMENT • HICKORY • COLONIAL

GOLDEN WORLD • CONSTELLATION • TCF

WON'T YOU JOIN US!

NEXT YEAR WE WILL BE 4 YEARS OLD

MERIT MUSIC DISTRIBUTORS, INC.

15773 Wyoming Avenue

Detroit 38, Michigan

(313) UN 3-9119

The effective distributor in the Northwest . . .

INDEPENDENT RECORD SALES

division of the

Craig Corporation

Best promotion—Large Sales Force—Product Concentration
Triple-A-1 D & B rating

Contact: Jerry Dennon, Sales Manager

Craig Corporation, Independent Record Sales Div.,

1021 E. Pine Street, Seattle, Wash. 98122. (206) EAst 4-3939

PETER NERO

Emperor of the keyboard



FORTHCOMING

August 25th through September 20th
London, England

- Two Guest Appearances
"The Kathy Kirby Show"
BBC-TV
- Four Peter Nero Specials
"Peter Nero In Person"
BBC-TV





LATEST ALBUM

NERO GOES "POPS"

With Arthur Fiedler
And The Boston Pops Orchestra
LMLSC 2821



RCA VICTOR

 The most trusted name in sound 



MANAGEMENT
STAN GREESON ASSOCIATES, INC.



REPRESENTATION



ITA

RECORD PRESSERS

•Independent Record Mfrs. Ass'n
•Western Record Pressers Ass'n

Abby Record Mfg.
1 Central Ave.
E. Newark, N. J.

AFM Engineering
6201 Santa Monica Blvd.
Los Angeles, Calif.

A. A. Allen Revivals, Inc.
P. O. Box 8595
Dallas, Texas

••Alberti Record Mfg. Co.
1300 West Garvey Blvd.
Monterey Park, California

••Alco Research & Engineering
6201 Santa Monica Blvd.
Los Angeles 38, Calif.

•All Disc Records, Inc.
625 W. First Ave.
Roselle, N. J.

Allentown Record Co., Inc.
10th & Walnut Sts.
Allentown, Pa.

••Allied Record Mfg. Co.
1041 N. Las Palmas Ave.
Hollywood, Calif.

•Amer. Record Pressing
1810 W. King St., Owosso, Mich.

A-N-L Recording Corp.
4465 North Lincoln Ave.
Chicago 25, Illinois

Arrow Record Mfg. Co.
5212 East 14th St.
Oakland, California

Audiofax
821 19th Ave. S.
Nashville, Tenn.

Banaba Music Co.
2452-6 South Kedzie
Chicago 23, Ill.

Bard Record Co.
66 Mechanic St.
New Rochelle, N. Y.

Bestway
Globe Ave., Mountainside, N.J.

Brunswick Radio
Div. of Decca Records
Route 30A
Gloversville, N. Y.

Brunswick Radio Div. of Decca Records
Pinckneyville, Ill.

(Continued on next page)

RECORD DIST.

and the lines they handle

SEATTLE Continued from page 84

Fidelity Electric
5301 Shilshole Avenue NW
W. J. Tolles—SU 4-9100
(RCA Victor, RCA Comden, Victrola, Groove, Comeo, Parkway, Artia, Philips, Kopp, Vox, Oldies 45, Living Language)

Hector Dist. Co.
2901 Second North
Ron Lampkin—AT 3-4226
(Aeolion-Skinner, Acodemy, Arhoolie, Austin, Audiophile, Bert & L, Blues Classico, Bortok, Boston, Cantate, Cook, Dorion, Educa, Evergreen, Fidelity Sound Recordings (FSR), Keone, Hoydn Society, Lexington, M.E.A., Music Library, Murnil, Origin Jazz Library, Piedmont, Rococo, Southland, Spo, Spoken Arts, Toad, Ultraphone)

Huffine Dist. Co.
3131 Western Avenue
Andy Huffine—AT 4-8633
(Amy, Audio Fidelity, Colpix, Crescendo, Dimension, GNP, Gordy, Hickory, Molo, Motown, MMO, Tomlo, Veejay, Westminster, King, Federal, Deluxe)

Independent Record Sales
1021 East Pine St.
Jerry Dennon—Ea 4-3939

(Annette, A&M, Almo Int'l., Arlen, Audio Recording, Arc, Apollo, Circo, Chart, Charter, Congress, Counterpoint, Dart Record Soles, Dore, Everest, Ember, Ero, Froternity, Fober, Gardeno, Hall, Holl-Way, Herold, Instant-Language, Jerden, Koy-Bee, Kosh, Lecam, Okeh, Original Sound, One-Der-ful, Prestige, Philles, Phil Spector Records, Pacific Jazz, Regina, Request, Sims, Specialty, Simon Soys, Scepter, Spokone, Tri-Disc, Teordrop, Wond, World Pacific, Panorama, Four Corners, Almond, Omen)

Music Dist.
1000 1st So.
Stan Sulmon—Mu 2-7188
(Mercury, Imperial, Folkways, Smosh, United Artists, Vanguard, Commond, Grand Award)

WISCONSIN

MILWAUKEE—(414)
Beckerman Dist. Inc.
423 No. 3rd St.
Harry Beckerman—842-3255
(Amy/Molo, Audio Fidelity, Canadian American, Colpix/Dimension, D.C.P., Dooto, Everest, Scepter/Wand, Somo, Stereodiddies, Vee Joy, Data, Constellation, Eurotone, Dunhill)

Morley-Murphy Co.
5151 West State St.
Henry Aubuchon—453-7200
(Columbia)

John O'Brien Dist. Inc.
2830 W. Vliet St.
John O'Brien—DI 4-3560
(Argo, Atlantic, Blue Note, Codence, Corlton, Checker, Chess, Concert Disc, Del-Fi, Donna, Dictation, Disc End, Everest, Fober, Fantasy, Gone, Gordy, GNP, Guyden, Hi-Fi, Hollywood, Imperial, Jamie, Joy, Kandy, Life, Lupine, Minit, Musicor, Old Town, Original Sound, Pogent, Philles, Pip, Polkalond, Prestige, Roost, Roulette, Select, Smosh, Specialty, Starday, Stax, Tico, Tomla, 20th Century Fox, Time, United Artists, Veejay)

Taylor Electric Co.
4084 N. Pt. Washington Road
Peter Stocke—Wo 4-4321
(RCA Victor, RCA Comden, RCA Victrola, Allegro, Cricket, Cuca, Happy Time, Hilltop, Pickwick)

PUERTO RICO

BAYAMON
Fortaleza Record Dist. Inc.
P.O. Box 612
Tony Rivera—785-9966
(Most U.S. lines available)

KAYBANK OF MINNEAPOLIS

ONE-STOP SERVICE . . . ONE SUPPLIER RESPONSIBILITY

1. PRESSING—Fully Automatic Presses . . . Extruders . . . Drop Shipment.
2. PLATING—Sulfamate Nickel
3. MASTERING—Scully Lathe, Variable Pitch.
4. STUDIO TAPING—3- & 4-Track, Echo Chambers.
5. ALBUM DESIGN & PRINTING
6. ALBUM ASSEMBLY

CONTACT: Vern Bank, Kaybank Recording Corp.
2541 Nicollet Ave., Minneapolis 55404
827-5441 (Area 612)

THE TOP QUALITY PRESSINGS COME FROM

MGM

A DIVISION OF METRO-GOLDWYN-MAYER

MAKES RECORDINGS • MAKES MASTERS • MAKES PRESSINGS

MAKES STEREOs • MAKES SHIPMENTS (AND WAREHOUSES)

PARTS SHIPPED ALL OVER THE WORLD

with the efficiency, the quality, the technical mastery that
has always been associated with the name of M G M!

WRITE FOR FREE CATALOG

For information concerning our custom services,
contact Frank Cocchiaraley, Director
M G M RECORD MANUFACTURING DIVISION
120 Arlington Ave., Bloomfield, N. J.
Pilgrim 3-5300

Even the staff members who are sitting, stand for something.



RELIABILITY. Everyone at Columbia Record Productions makes it a byword—in both order service and sales. Reliability that means your custom record order will be expedited promptly and delivered on time. Shipments leave the factory and arrive by low-cost truck at 85% of the country's record markets, overnight. Columbia Record Productions has three plants, strategically located in New Jersey, Indiana and California. There are no unnecessary delays. Each has the capacity to produce large quantity and high quality work. You also receive the gratifying reflected saving to the distributor because of

the great volume of records sent from the plants in consolidated shipments. Let us prove the reliability that this complete operation promises. Call or write today.

(Back row—left to right): Floyd Glinert, Dan Allen, Art Adler, Bob Teitelman, Ted Hajna, David Hyman, Ernest Ferrari. (Middle row—left to right): Jerry Parkins, Dick Hutter, J. K. Maddox, Mike Coolidge, Norman Dolph, Joe Bakcsy, David Grant, Calvin Roberts. (Sitting down—left to right): Ken Groves, Stan Marshall, George Costello, Tom Van Gessel.

COLUMBIA RECORD PRODUCTIONS

Sales Offices: 51 West 52 Street • New York, New York 10019 • 765-4321 / 2990 West Grand Boulevard • Detroit, Michigan • TR 1-6110
630 North McClurg Court • Chicago, Illinois • WH 4-6000 / 804 16th Avenue South • Nashville, Tennessee • AL 4-5578
6121 Sunset Boulevard • Hollywood, California • 466-2481 / Factories: Pitman, New Jersey • Terre Haute, Indiana • Santa Maria, California

SPECIALTY

**MAKES PERSONALIZED
SERVICE REALITY**

FROM TAPES TO YOUR
COMPLETED PRODUCT

A QUALITY PRESSING PLANT
for
7", 10", and 12" RECORDS
ALL SPEEDS

SPECIALTY RECORDS CORPORATION



FABRICATORS OF *Phonograph Records*

210 NORTH VALLEY AVENUE
OLYPHANT, PENNA. 18447

RECORD PRESSERS

Cadet Record Pressing Co.
146 W. 37th Pl.
Los Angeles, Calif.

Capitol Custom
151 West 46th St.
New York, N. Y.

Capitol Custom
3061 Fletcher Dr.
Hollywood, Calif.

Capitol Custom
300 Brook St.
Scranton, Pa.

Capitol Custom
1 Capitol Way or Box 385
Jacksonville, Ill.

Cavendish Record Mfg. Co.
5810 South Normandie
Los Angeles, Calif.

●●Century Record Mfg. Co.
Poly Laboratories, P.O. Box 30
Saugus, California

Clarion Record Mfg. Co. Inc.
1021 Ridge Ave.
Philadelphia 23, Pa.

Clark Phonograph Record
718 Wilhelm
Harrison, N. J.

Coast Record Mfg. Co., Inc.
2846 W. Pico Blvd.
Los Angeles, Calif.

Columbia Custom
Lamb & Woodbury Rd.
Pitman, N. J.

Columbia Custom
799 7th Ave.
N. Y., N. Y.

Columbia Custom
1400 N. Fruitridge Ave.
Terre Haute 14, Ind.

Columbia Custom
900 E. Stowell Rd.
Santa Maria, Calif.

Columbia Custom
630 N. McClurg St.
Chicago, Ill.

Columbia Custom
2990 W. Grand Blvd.
Detroit, Mich.

Columbia Custom
804 16th Ave.
Nashville, Tenn.

Columbia Custom
6121 Sunset Blvd.
Hollywood, Calif.

Columbia Custom
8723 Alden Dr.
Los Angeles 48, Calif.

Cook & Associates
5905 W. Slauson Ave.
Los Angeles, Calif.

Creative Sound Productions
9000 Sunset Blvd.
Los Angeles, Calif. 90069

Crown Records
9317 W. Washington Blvd.
Culver City, Calif.

Decca Records
6750 Santa Monica Blvd.
Hollywood, Calif.

●Diskmakers, Inc.
1401 S. 10th St.
Philadelphia, Pa.

Dunn Record Pressing Co.
4756 S. Cottage Grove Ave.
Chicago, Illinois

Dynamic LP Stereo
900 Passaic Ave.
East Newark, N. J.

(Continued on next page)

ALLENTOWN

RECORD COMPANY, INC.

CELEBRATES ITS 20th YEAR

AS A CUSTOM MOULDER FOR THE RECORD INDUSTRY

- WE FUNCTION AS YOUR PLANT. WE DON'T HAVE A PROPRIETARY PRODUCT TO WORRY ABOUT.
- WE CAN AND DO TURN OUT OVER 40,000 12" RECORDS A DAY.
- WE USE "DRY BLEND" PRIME GRADE VINYL FREE OF PREVIOUS HEAT HISTORY AND COMPOUNDED RIGHT AT THE PRESS.
- WE ARE COMPLETELY INTEGRATED WITH OUR OWN CUTTING STUDIO, PLATING PLANT, JACKET PLANT AND PRINTING PLANT.
- NOTHING IS TOO MUCH TROUBLE FOR US.
- OUR CHARGES ARE MOST COMPETITIVE.
- WE ARE WITHIN ONE DAY DELIVERY OF OVER 52% OF THE NATIONAL MARKET.

NEW high speed AUTOMATIC
PLATING INSTALLED . . .
one day SERVICE . . .
MASTER . . . MOTHER
& STAMPER

ALLENTOWN RECORD CO., INC.

S.L. WARTELL

Area Code 215 433-7405
ALLENTOWN, PA.



Why take slow for an answer?

Capitol Custom takes the shortest possible time—while giving the highest possible quality—between lacquer mastering and finished product.

You never take slow for an answer.

Capitol has studios in Hollywood and New York City.

Pressing plants East and West, too. One of the world's largest in Scranton, Pa. The world's most modern in Los Angeles. If your distribution needs twin-coast production, lacquers can be produced in New York and Hollywood simultaneously to save time.

And you can be sure that the same strict quality control of a Capitol product is applied to your pressing as well.

That's why people who think twice before going on record use Capitol Custom Services. They've found they get the best of everything—high-speed service and quality sound. And they've found they pay no more—in fact, they often pay less—for the best!

Capitol Custom Services  1750 N. Vine Street, Hollywood 28, California Hollywood 2-6252
151 West 46th Street, New York 19, New York Judson 2-8040

Be quick about it.

RECORD PRESSERS

• Empire Record Co.
800 E. 141 St.
Bronx 54, N. Y.

Falcon Records
2616 Crooks Rd.
Royal Oak, Mich.

Flama Record Co.
35-47 31st St.
Long Island City, N. Y.

Four Star Record Co.
305 Fair Oaks
Pasadena, Calif.

Gem Custom
(Formerly Royal Plastics)
1540 Brewster Ave.
Cincinnati, Ohio

Gospel Recordings, Inc.
146 Glendale
Los Angeles, Calif.

Hodge Record Mfg. Co.
3208-16 So. 84th St.
Philadelphia, Pa.

Houston Record Company
3318 Jensen Drive
Houston, Texas

Ideal Recording Co.
P. O. Box 861
San Benito, Texas

Jay Jay Record Company
2456 South Kedzie
Chicago, Illinois

J. B. Research & Development
1117 East Redondo Blvd.
Inglewood, Calif.

• Kay Records, Inc.
110 Bergen Pike, Little Ferry, N.J.

Kay Bank Recording
2541 Nicollet Ave., Minn., Minn.

King Records
1540 Brewster Ave.
Cincinnati, Ohio

Kiski Recording Co.
Box 116
North Apollo, Pa.

•• Korelich Engineering Mfg. Co.
1141 N. Highland
Los Angeles, Calif.

James J. Lee Record Processing
9040 Culver Blvd.
Culver City, Calif.

Lewis Record Mfg. Co.
307 East Beach Ave.
Inglewood 3, Calif.

MGM Records
120 Arlington Ave.
Bloomfield, N. J.

C. P. MacGregor
729 S. Western
Los Angeles, Calif.

Mecca Records
920 3rd Ave., Seattle 4, Wash.

Mercury Records
35 E. Wacker Drive
Chicago, Ill.

Miami Pressers
2819 N. W. 7th Ave.
Miami 37, Fla.

Midwest Record Pressing
7007 S. Wentworth Ave.
Chicago 21, Ill.

Miller International Co.
P. O. Box 45
Swarthmore, Pa.

•• Minato Record Pressing Co.
2667 Long Beach Ave.
Los Angeles 58, Calif.

Mission Aids, Inc.
100 East Montecito
Sierra Madra, Calif.

Monarch
4852 W. Jefferson Blvd.
Los Angeles, Calif.

Musical Products Company
561 West 16th St.
Chicago 16, Illinois

National Recording
2871 E. Ponce De Leon
De Catur, Ga.

Norman Record Pressing
1486 N. Fair Oaks
Pasadena, Calif.

(Continued on next page)

ALL DISC RECORDS

the independent plant for independent labels

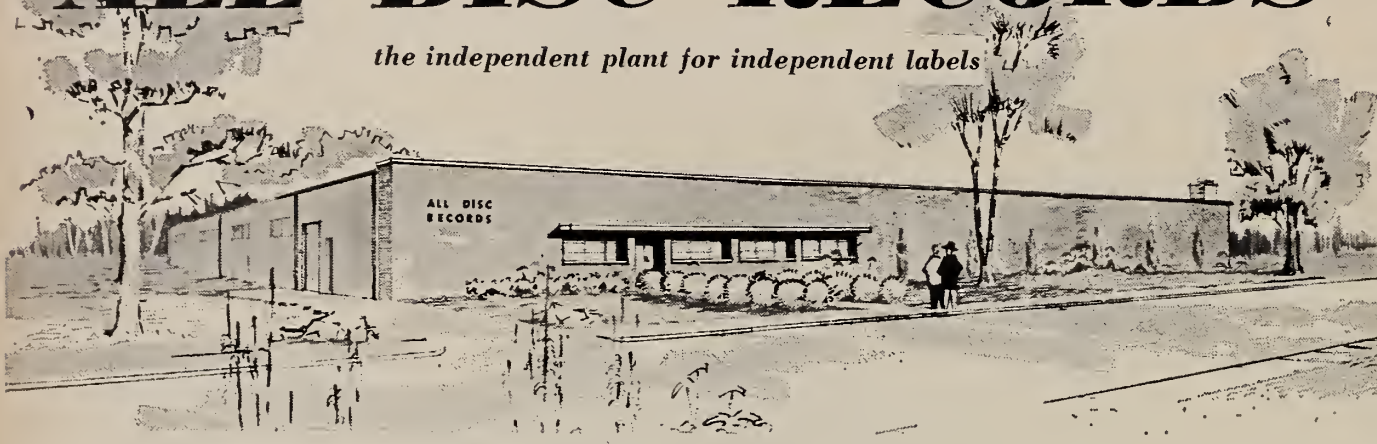

QUALITY AND SERVICE

are responsible for our rapid growth to this one-acre modern Plant and Warehouse

MODERN FACILITIES • DEPENDABLE SERVICE • SUPERB QUALITY

Versatility—6"—7"—12" Vinyl • East Coast Polymax Licensee
Complete Responsibility From Tape to Drop Shipping

We do not own a label—therefore all our efforts are for your benefit.

ALL DISC RECORDS

625 W. FIRST AVE., ROSELLE, NEW JERSEY

N. J. Phone: CHestnut 5-7415

N. Y. Phone: COrtland 7-1523

NOBODY CAN MATCH BESTWAY'S SERVICE

BESTWAY feels that a promise is something special and has to be kept. Maybe that's what accounts for our reputation.

BESTWAY DELIVERS WHAT YOU WANT . . . WHEN YOU WANT IT (if not sooner)

Specializing in:

**CUSTOM PRESSING . . .
FROM PLATE TO COMPLETED PRODUCT . . .
LABELS . . . WAREHOUSING . . .
DROP SHIPPING . . .**



BESTWAY PRODUCTS

MOUNTAINSIDE, NEW JERSEY (201) ADAMS 2-8383

**FACE
THE
FACTS !!!**

**LONG WEAR STAMPER
DOES
A
BETTER JOB
FOR
YOU**

We specialize in record plating !

Our Technicians devote full effort
to give you the best product !

Plating is our only endeavor !

We give you expert service !

Personal attention !

Ultimate in quality through the
latest equipment and methods
available !

SEE FOR YOURSELF

Call: **JACK BERMAN**
(212)EX2-4718

LONG WEAR STAMPER CORP.

36-41 36th St. Long Island City 6, N.Y.

CUSTOMATRIX IS SOMETHING TO CELEBRATE. Champagne is in order for the specialized matrix service inaugurated one year ago in the East, Midwest and Far West by Columbia Record Productions. Since then, record pressers, studios and manufacturers have enjoyed the low prices, high quality and large production capacity at their command. It would be our pleasure to quote prices on your metal parts requirements for manufacturing or export. Now, more than ever, we can serve you as no other matrix service can! For information contact: Norman Dolph, 765-4321, extension 4788.

CUSTOMATRIX

A Service of Columbia Record Productions
799 Seventh Avenue, New York, N.Y. 10019

Congratulations CASH BOX

*Where Independents
Meet Independents*

**For Continuing Success, Press
With Your Independent Pressing Plant**

MONARCH

RECORD MFG. CO.

**A Division of THE COSNAT CORPORATION
4852 W. Jefferson Blvd., Los Angeles 16, Calif.**



SILVER PLASTICS INCORPORATED

**SPECIALIZING IN SERVICE & DEPENDABILITY
FOR LEADING INDIE RECORD COMPANIES**

SILVER PLASTICS INC.

SOUTHAMPTON INDUSTRIAL HIGHWAY
SOUTHAMPTON, PA.

(215) ELMWOOD 7-1175

(215) HOBART 4-3270

PRESSERS

Parliament Records
Box 341-A, RD2
Parkesburg, Pa.

• Paramount Record Mfg. Co.
1314 S. Howard St.
Philadelphia, Pa.

Peacock Records
2809 Erastus St.
Houston, Texas

Peerless Record Corp.
2820 W. Pico
Los Angeles, Calif.

Plastic Products
1746 Chelsea Ave.
Memphis, Tenn.

Plastylite Corp.
333 North Drive
North Plainfield, N. J.

Premier Albums of N. J.
140 Delawanna Ave.
Clifton, N. J.

Presswell Records, Inc.
White Horse Pike & Bates Mill Road
Anchorage, N. J.

Purdy Records
1721 Broadway
New York 19, N. Y.

• Rainbow Record Mfg. Corp.
4335 West 147th
Lawndale, Calif.

Raleigh Records, Inc.
881-7th Ave.
New York, N. Y.

RCA Custom Record Sales
501 North La Salle Street
Indianapolis, Indiana
ME 6-5321

(Continued on next page)

Complete

Facilities for:

- LABELS
- PRESSING
- MATRIX

• Since 1945 •

**Alco Research &
Engineering, Inc.**

6201 Santa Monica Blvd.
Hollywood 38, Calif.



SOUTHERN PLASTICS INCORPORATED

453 CHESTNUT STREET
NASHVILLE, TENNESSEE
Tel: 244-1293

*Custom Record Pressing
Supplying the South*

*For QUALITY
and SERVICE
in the MIDWEST and EAST*

*The American
Record Pressing Co.*

1810 W. King Street Owosso, Michigan Tel. SA 5-8176



RECORD PRESSERS

RCA Custom Record Sales
445 North Lake Shore Drive
Chicago 11, Illinois
WH 4-3215

RCA Custom Record Sales
6363 Sunset Blvd.
Hollywood 28, California
HO 1-9717

RCA Custom Record Sales
1016 North Sycamore
Hollywood 38, California

RCA Custom Record Sales
155 East 24th Street
New York 10, New York
MU 9-7200

RCA Custom Record Sales
Rt. 46 & Greenpond Road
Rockaway, New Jersey
OA 7-2400

RCA Custom Record Sales
800 17th Avenue South
Nashville 3, Tennessee
AL 5-5781

Record Broadcast
237 S. Bent Ave.
San Marcos, Calif.

Record Pressing
145 West 154th St.
Gardena, Calif.

Recordings, Inc.
1130 E. Cold Spring La.
Baltimore, Md.

Research Craft Company
1011 North Fuller Ave.
Los Angeles 46, Calif.

Rite Records
3930 Spring Grove Ave.
Cincinnati 23, Ohio

Romaba Records Co.
33 Thirty Fourth St.
Brooklyn, N. Y.

R.P.I.
151 W. 154th St.
Gardena, Calif.

S. F. Record Mfg. & Matrix Co.
1038 Taraval St.
San Francisco 16, Calif.

S & R Record Mfg. Co.
16508 So. Main St.
Gardena, Calif.

San Marcos Record Company
1149 J Bent Ave.
P. O. Box 278
San Marcos, Calif.

Shelley Products
220 Broadway
Huntington Station, L. I., N. Y.

Silver Park Records
286 Kinderkermack Road
Riveredge, N. J.

Silver Plastics
Southampton Industrial Highway
Southampton, Pa.

Sonic Recording
27 Ludy St.
Hicksville, L. I., N. Y.

Sound of Nashville
160 2nd Ave., So.
Nashville, Tenn.

Southern Plastics
453 Chestnut St., Nashville, Tenn.

Sparton of Canada, Ltd.
London, Ontario, Canada

Specialty Records
210 North Valley Ave.
Olyphant, Pa.

Standard
415 Fourth Ave. S.
Nashville, Tenn.

(Continued on next page)



OUR SERVICE IS

THE FINEST

AND INCLUDES...

- PRESSING
- LABELS
- MASTERING
- WAREHOUSING
- DROP SHIPPING

Ideally located to serve the Midwest, South and Southwest



Manufacturers of Plastic Products

1746 Chelsea Ave., Memphis 7, Tennessee. BR 6-7160.

Plant and Sales Office—Area (601)-622-4341

DON'T CALL US

For Record Pressing

UNLESS

You Want Quality
and Service
That's Unbeatable
Anywhere!

ALL SPEEDS

KAY RECORDS, INC.

110 Bergen Pike, Little Ferry, N. J.
Diamond 3-5721-2

**MATRIX
PLATING**

Masters, Mothers,
Stampers, Converts
Or Nickel.

Fast Service—Check Our Prices.
Satisfaction Guaranteed.
Send Your Tapes.
Same Day Service.
Write For Our Price List.

S. J. SHAW PLATING CORP.
2604 Glendora Ave., Cincinnati 19, O.
Phone: WOODBURN 1-3058

CUSTOM PRESSING

GEM CUSTOM RECORD SERVICE
(formerly Royal Plastics)

The Nation's Only One-Stop
Record & Album Maker

Plating • Pressing • Printing • Collating • Art Studio
Lithographing — write for complete details

1540 BREWSTER AVE. CINCINNATI, OHIO 45207
PHONE 751-2211



Complete

CUSTOM RECORD PRESSING SERVICE

From Recording to National Distribution

All Speeds

LABELS • PLATING • PRESSING • SHIPPING

Fastest Service Anywhere

CONTACT RALPH PATE
at plant address below:

PHONO RECORD PRESSING COMPANY

95 1st STREET, GRETNA, LOUISIANA PHONE: NEW ORLEANS (AREA CODE 504) 367-8822

RECORD PRESSERS

Starday Records
1248 S. Berendo St.
Los Angeles, Calif.

©Sun Plastics
900 Passaic Ave.
East Newark, N. J.

• Superior Recordings Co., Inc.
1023 North LaBrea
Hollywood, Calif.

Tanner "N" Texas, Inc.
1422 W. Popular St.
San Antonio, Texas

Tops Records
5810 S. Normandie
Los Angeles, Calif.

Union City Plastics
716-22nd St.
Union City, N. J.

• United Records
111 New Jersey Railroad Ave.
Newark, N. J.

United Recorders
535 No. Fairfax
Los Angeles, Calif.

Universal
1244 Dufferin St.
Toronto 4, Ont.

••H. V. Waddell
231 W. Olive
Burbank, Calif.

Sidney J. Wakefield
P.O. Box 6037
Phoenix, Ariz.

Western Custom
16909 So. Broadway
Gardena, Calif.

Wildcat Records, Inc.
P. O. Box 207
San Antonio, Texas

Windsor Records
830 River Drive, Garfield, N.J.

SERVICES

Smith's Personnel Service
251 West 42nd St.
New York, New York—WI 7-3806

Complete, Quick Service
PROCESSING • LABELS
PRESSINGS • DROP SHIPMENTS

CENTRALLY LOCATED
for Custom Work at Economy Prices
JAMES GANN **RUSS FRATTO**

MIDWEST RECORD PRESSING, INC.

7007 South Wentworth Ave. Chicago 21, Illinois
PHONE: ST 3-4150

Sidney J. Wakefield

CUSTOM RECORD PRESSING

P. O. BOX 6087 PHOENIX, ARIZONA 85005
AREA CODE 602-252-5644

PRECISION PRODUCT
RAPID SERVICE
COMPETITIVE PRICING

Superlative Quality
On time deliveries
Newest ultra-modern equipment
Included services: Nickel Plating,
Pressing, Warehousing
Competitive prices



Sonic's reputation for top-quality LP and Stereo work
and service has been earned. Call or write

SONIC RECORDING PRODUCTS, INC.

27 Ludy St., Hicksville, L.I. N.Y. 516-Wells 8-2600

finebilt

SERVING THE SOUND INDUSTRY

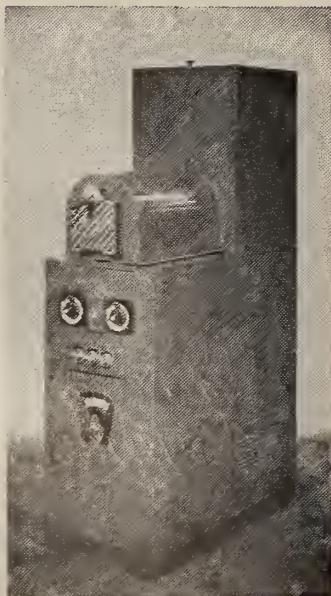

**MOBILE
CONSOLE TYPE,
COMPACT,
FAST EXTRUDER
USES DRY BLEND,
GRANULES, PELLETS,
REGRINDS.**

**FEEDS TWO LP PRESSES
OR FOUR 45 PRESSES
MINIMUM
MAINTENANCE**

**FINEBILT PHONOGRAPH RECORD
PRESSING EQUIPMENT**

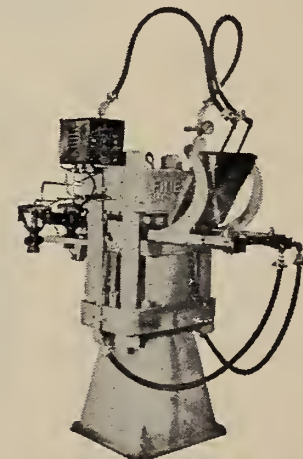

Finebilt automatic precision presses
with push button automatic control.
Mold closes—goes into press—mold
comes out and opens. All motions are
automatic. No skilled help required.
One operator handles two presses.

ASK FOR CATALOGUE

RECORD PLATING PLANTS

• Independent Record Mfrs. Association
• Western Record Pressers Association

• AFM Engineering Company
6201 Santa Monica Blvd.
Hollywood, Calif.

• Alco Research & Eng. Inc.
6201 Santa Monica Blvd.
Hollywood 38, Calif.

• Allentown Record Co. Inc.
10th & Walnut Sts.
Allentown, Pa.

• Allied Record Mfg. Co.
1041 N. Las Palmas
Hollywood 38, Calif.

• Audio Matrix
915 Westchester Ave.
New York, N. Y.

• Audio Plating
1037 North Sycamore
Hollywood, Calif.

• Cadet Record Pressings Co.
146 W. 37th Pl.
Los Angeles, Calif.

• Century Record Mfg.
Sangus, Calif.

Chicago Matrix, Inc.
4750 S. Cottage Grove Ave.
Chicago, Ill.

Coldwater Industries Inc.
Coldwater, Miss.

Cook & Associates Recorders
3905 W. Slauson Ave.
Los Angeles 43, Calif.

Dulcet Tone Corp.
12-14 B'way
Long Island City, N. Y.

Finebilt
931 North Citrus Ave.
Hollywood 38, Calif.

King Records
1540 Brewster
Cincinnati, Ohio

• James G. Lee Record Processing
145 W. 154th Rd.
Los Angeles, Calif.

• Long Wear Stamper Corp.
36-41 36th St.
Long Island City 6, N. Y.

• Mastercraft Record Plating
619 West 54th St.
New York, N. Y.

MGM Record Mfg. Div.
120 Arlington Ave.
Bloomfield, N. J.

• Monarch Record Mfg.
4852 W. Jefferson Blvd.
Los Angeles, Calif.

Plastic Products
Memphis, Tenn.

R. M. Record Matrix Co.
546 N. Fair Oaks
Pasadena, Calif.

• Research Craft Plastics Corp.
1011 N. Fuller
Los Angeles, Calif.

Rite Record Productions, Inc.
3930 Spring Grove Ave.
Cincinnati, Ohio

Shaw Plating Corp.
2604 Glendora Ave.
Cincinnati, Ohio

Ultra Electroforming Co.
110 Cedar Ave.
Pitman, N. J.

Materials Milling Plants (Biscuits)

• Independent Record Mfrs. Association
• Western Record Pressers Association

Allied Recording Products Co.
3232 Greenpoint Ave.
Long Island City, N. Y.

Aragon Products
639 Island View Dr.
Santa Barbara, Calif.
or
36 Legal Street
Newark 12, New Jersey

Barb Inc.
Globe Ave.
Mountainside, New Jersey

Camden Plastics Assoc.
21624 Michle Street
Camden 3, N. J.

Carey Corp.
1128 Rider's Lane
East Brunswick, N. J.

Cavendish Mill
17705 S Broadway
Gardena, Calif.

• Collins Caldwell Dague
16616 Garfield
Paramount, Calif.

Commodore Record Corp.
232 D Lake Ave.
Yonkers, N. Y.

Customatrix
799 7th Ave.
New York, N. Y.

Customatrix
Lamb & Woodbury Rd.
Pitman, N. J.

Customatrix
1400 Fruitridge Ave.
Terre Haute, Ind.

Customatrix
900 East Stowell Rd.
Santa Maria, Cal.

• Dean Hubbard Plastics
1011 N. Fuller
Hollywood, Calif.

• Keysor Chemical Co.
P. O. Box 308
26000 Bocequet Canyon
Sargus, Calif.

• Lenahan Associates Inc.
North Summit Ave.
Pitmar, N. J.

Marshall Sales & Export Corp.
P. O. Box 46
Bridgeport, Pa.

• J. W. Neff Laboratories, Inc.
Stockertown, Pa.

• Pilot Rubber & Plastics
3823 24th St.
Long Island City, N. Y.

• Record Biscuits Inc.
1909 North Central
El Monte, Calif.

• Research Craft Plastics
1011 N. Fuller
Los Angeles, Calif.

Thompson Records
Perryville Rd.
Webster, Mass.

Valite Co.
New Orleans, La.

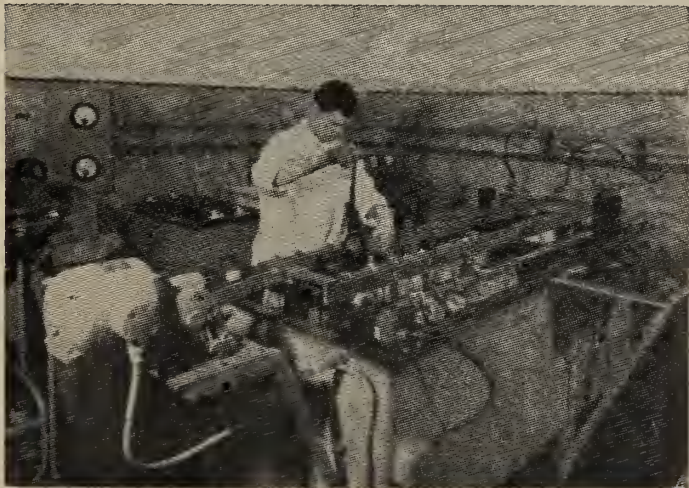

Nickel sulfamate installation for processing .010" thick finished solid nickel masters, mothers, stampers in 3-1/2 hours. Eight position—twelve position—twenty position. Completely assembled. Ready to operate.

FINE-COAT MAGNETIC RECORDING TAPE MANUFACTURING EQUIPMENT

A complete plant package to fit your requirements. Compact, automatic tape manufacturing plant. Produces the highest quality recording tape at a minimum investment. It consists of: automatic coater, slitter, rewinder, degauser, testing equipment. We furnish complete plant layout, installation, supervision, operator's training, consultation service. Initial equipment investment paid for in the first year of operation.



ASK FOR BROCHURE

FINEBILT MANUFACTURING CO.

931 North Citrus Avenue,
Hollywood 38, Calif.

(Export Division: Coast Export Company, Inc. CODE: COEXPORT Phone Hollywood 6-9511

Finebilt has been awarded the Presidential "E" for excellence in Export.

GOLDEN ALBUMS

THE LIST OF ALBUMS BELOW REPRESENTS THOSE RELEASES THAT THE RECORD INDUSTRY ASSOCIATION OF AMERICA (RIAA) HAS CERTIFIED AND AUDITED AS HAVING EACH SOLD AN AMOUNT WORTH AT LEAST \$1 MILLION AT FACTORY PRICES. THEY CONSTITUTE, NEEDLESS TO SAY, THE EVERGREEN CATALOG OF LP MERCHANDISE—IN ALL PHASES OF MUSIC—CURRENTLY AVAILABLE. THERE IS ALWAYS CONSUMER INTEREST IN THEM, AND WISE IS THE DEALER WHO CAN IMMEDIATELY FULFILL THE REQUEST FOR MOST, IF NOT ALL OF THE GOLD-DISK ALBUMS. DISPLAY OF THIS SHEET ALONG SIDE A BROWSER CALLED "GOLDEN ALBUMS" COULD INCREASE SALES.

1958

OKLAHOMA—Gordon MacRae—Capitol WAO-595

1959

HYMNS—Ernie Ford—Capitol T-256

JOHNNY'S GREATEST HITS—Johnny Mathis—Columbia CL-1133

MUSIC MAN—Original Cast—Capitol WAO/SWAO-990

SING ALONG WITH MITCH—Mitch Miller—Columbia CL-1160/CS-8004

SOUTH PACIFIC—Rodgers & Hammerstein—RCA Victor LOC/LSO 1032

PETER GUNN—Henry Mancini—RCA Victor LPM/LSP 1956

1960

STUDENT PRINCE—Mario Lanza—RCA Victor LM-1837

60 YEARS OF MUSIC—Honoring 30 Great Artists—RCA Victor LM-6074

ELVIS—Elvis Presley—RCA Victor LPM-1382

PAT'S GREAT HITS—Pat Boone—Dot 3071/25071

KINGSTON TRIO AT LARGE—Kingston Trio—Capitol T-1199

KINGSTON TRIO—Kingston Trio—Capitol T-996

MORE SING ALONG WITH MITCH—Mitch Miller—Columbia CL-1243/CS-8043

HEAVENLY—Johnny Mathis—Columbia CL-1351/CS-8152

WARM—Johnny Mathis—Columbia CL-1078/CS-8039

LOVE IS THE THING—Nat King Cole—Capitol W-824

HERE WE GO AGAIN—Kingston Trio—Capitol T-1258

FROM THE HUNGRY I—Kingston Trio—Capitol T-1107

SOUND OF MUSIC—Original Cast—Columbia KOL-5450/KOS-2020

MERRY CHRISTMAS—Johnny Mathis—Columbia CL-1195/CS-8021

CHRISTMAS SING ALONG—Mitch Miller—Columbia CL-1205/CS-8027

STILL MORE I SING ALONG—Mitch Miller—Columbia CL-1283/CS-8099

1961

CALCUTTA—Lawrence Welk—Dot DLP-3359/ST-25359

COME DANCE WITH ME—Frank Sinatra—Capitol W-1069/WS-1069

SOLD OUT—Kingston Trio—Capitol T-1352/ST-6352

GLENN MILLER STORY—Glenn Miller Orchestra—RCA Victor LPM-1192

CHRISTMAS CAROLS—Mantovani—London LL-913/PS-142

THEATRE LAND—Mantovani—London LL-1219/PS-125

FILM ENCORES VOL. I—Mantovani—London LL-1700/PS-124

GEMS FOREVER—Mantovani—London LL-3032/PS-106

STRAUSS WALTZES—Mantovani—London LL-685/PS-118

SPIRITUALS—Ernie Ford—Capitol T-818

ELVIS' GOLDEN RECORDS—Elvis Presley—RCA Victor LPM-1707

BELAFONTE AT CARNEGIE HALL—Harry Belafonte—RCA Victor LOC-6006/LSO-6006

TCHAIKOVSKY CONCERTO—Van Cliburn—RCA Victor LM-2252/LSC-2252

ENCORE-GOLDEN HITS—The Platters—Mercury MG-20472/SR-60243

BLUE HAWAII—Elvis Presley—RCA Victor LPM-2426/LSP-2426

HOLIDAY SING ALONG WITH MITCH—Mitch Miller—Columbia CL-1701/LS-8501

1962

PARTY SING ALONG WITH MITCH—Mitch Miller—Columbia CL-1331/LS-8138

MORE JOHNNY'S GREATEST HITS—Johnny Mathis—Columbia CL-1344/LS-8150

WEST SIDE STORY—Original Cast—Columbia OL-5230/OS-2001

CAMELOT—Original Cast—Columbia KOL-5620/KOS-2031

FLOWER DRUM SONG—Original Cast—Columbia OL-5350/OS-2009

THEME FROM A SUMMER PLACE—Billy Vaughn—Dot 3276/25276

BLUE HAWAII—Billy Vaughn—Dot 3165/25165

SAIL ALONG SILVERY MOON—Billy Vaughn—Dot 3100/25100

BOB NEWHART BUTTON DOWN MIND—Bob Newhart—Warner Bros. W-1379/WS-1379

SATURDAY NIGHT SING ALONG WITH MITCH—Mitch Miller—Columbia CL-1414/CS-8211

MEMORIES SING ALONG WITH MITCH—Mitch Miller—Columbia CL-1542/LS-8342

SENTIMENTAL SING ALONG WITH MITCH—Mitch Miller—Columbia CL-1457/LS-8251

STAR CAROL—Ernie Ford—Capitol T-1071/ST-1071

NEARER THE CROSS—Ernie Ford—Capitol T-1005/ST-1005

FRANK SINATRA SINGS FOR ONLY THE LONELY—Frank Sinatra—Capitol W-1053

NICE 'N' EASY—Frank Sinatra—Capitol W-1417

SONGS FOR SWINGIN' LOVERS—Frank Sinatra—Capitol W-653

STRING ALONG—Kingston Trio—Capitol T-1407

MUSIC, MARTINIS AND MEMORIES—Jackie Gleason—Capitol W-509

MUSIC FOR LOVERS ONLY—Jackie Gleason—Capitol W-352

JUDY AT CARNEGIE HALL—Judy Garland—Capitol WBO-1568

HAPPY TIMES SING ALONG—Mitch Miller—Columbia CL-1568/CS-8368

MEMORIES ARE MADE OF THIS—Ray Conniff—Columbia CL-1574/CS-8374

CONCERT IN RHYTHM—Ray Conniff—Columbia CL-1163/CS-8022

'S MARVELOUS—Ray Conniff—Columbia CL-1074/CS-8037

MODERN SOUNDS IN COUNTRY & WESTERN MUSIC—Ray Charles—ABC Paramount ABC-410/ABCS-410

BREAKFAST AT TIFFANY'S—Henry Mancini—RCA Victor LPM-2362/LSP-2362

THIS IS SINATRA—Frank Sinatra—Capitol T-768

BOUQUET—Fercy Faith Strings—Columbia CL-1322/CS-8124

SO MUCH IN LOVE—Ray Conniff—Columbia CL-1720/CS-8520

FAITHFULLY—Johnny Mathis—Columbia CL-1422/CS-8219

SWING SOFTLY—Johnny Mathis—Columbia CL-1165/CS-8023

OPEN FIRE, TWO GUITARS—Johnny Mathis—Columbia CL-1270/CS-8056

PETER, PAUL AND MARY—Peter, Paul and Mary—Warner Bros. W-1449/WS-1449

MY SON THE FOLK SINGER—Allan Sherman—Warner Bros. W-1475/WS-1475

THE FIRST FAMILY—Vaughn Meader—Cadence CLP-3060

1963

WEST SIDE STORY—Original Soundtrack—Columbia OL-5670/OS-2070

GLORIOUS SOUND OF CHRISTMAS—Eugene Ormandy—Philadelphia Orchestra—Columbia ML-5769/MS-6369

1812 OVERTURE-TSCHAIKOVSKY—Antal Dorati and The Minneapolis Symphony—Mercury MG-50054/SR-90054

EXODUS—Original Soundtrack—RCA Victor LOL-1058/LSO-1058

CALYPSO—Harry Belafonte—RCA Victor LPM-1248/LSP-1248

G. I. BLUES—Elvis Presley—RCA Victor LPM-2256/LSP-2256

SEASON'S GREETINGS FROM PERRY COMO—Perry Como—RCA Victor LPM-2066/LSP-2066

VIVA—Percy Faith—Columbia CL-1075/CS-8038

THE MUSIC MAN—Soundtrack—Warner Bros. B-1459/BS-1459

TIME OUT—Dave Brubeck Quartet—Columbia CL-1397/CS-8192

I LEFT MY HEART IN SAN FRANCISCO—Tony Bennett—Columbia CL-1869/CS-8669

ELVIS' CHRISTMAS ALBUM—Elvis Presley—RCA Victor LOC-1035/LPH-1951

GIRLS, GIRLS, GIRLS—Elvis Presley—RCA Victor LPM-2621/LSP-2621

BELAFONTE RETURNS TO CARNEGIE HALL—Harry Belafonte—RCA Victor LOC-6007/LSO-6007

BELAFONTE—Harry Belafonte—RCA Victor LPM-1150

JUMP-UP-CALYPSO—Harry Belafonte—RCA Victor LPM-2388/LSP-2388

MOVIN'—Peter, Paul & Mary—Warner W/WS 1473

EXODUS—Mantovani—London LL-3231/PS-224

DAYS OF WINE & ROSES—Andy Williams—Columbia CL-2015/CS-8815

MOON RIVER & OTHER GREAT MOVIE THEMES—Andy Williams—Columbia CL 1809/CS 8609

HANDEL'S MESSIAH—Eugene Ormandy & Philadelphia Orch.—Columbia M2L 263/M2S 607

CHRISTMAS WITH CONNIFF—Ray Conniff—Columbia CL 1390/CS 8185

THE LORD'S PRAYER—Mormon Tabernacle Choir—Columbia ML 5386/MS 6068

PORGY AND BESS—Original Sound Track—Columbia OL 5410/OS 2016

FOLK SONG SING ALONG—Mitch Miller—Columbia CL 1316/CS 8118

IN THE WIND—Peter, Paul & Mary—Warner Bros. WB 1507/WS 1507

SINGING NUN—Soeur Sourire—Philips PCC 203/PCC 603

1964

MY FAIR LADY—Original Cast—Columbia OL 5090/OS 2015

JOHN FITZGERALD KENNEDY—A MEMORIAL ALBUM—Premier CFX 402099

CAROUSEL—Film Soundtrack—Capitol W 694/ SW 694

THE KING AND I—Film Soundtrack—Capitol—W 74/SW 740

RAMBLIN' ROSE—Nat "King" Cole—Capitol T 1793/ ST 1793

MEET THE BEATLES—The Beatles—Capitol T 2047/ST 2047

HONEY IN THE HORN—Al Hirt—RCA Victor LPM 2733/LSD 2733

THE BEATLES' SECOND ALBUM—The Beatles—Capitol T 2080/ST 2080

THE SECOND BARBRA STREISAND ALBUM—Barbra Streisand—Columbia CL 2045/CS 8854

HELLO, DOLLY!—Original Cast—RCA Victor LCO 1087/LSO 1087

HELLO, DOLLY!—Louis Armstrong—Kapp 1364/3364

THE WONDERFUL WORLD OF ANDY WILLIAMS—Columbia CL-2137/CS-8937

CHRISTMAS HYMNS & CAROLS—Robert Shaw—RCA Victor LM-2139/LSC-2139

VICTORY AT SEA, Vol. 1—Robert Russell Bennett—RCA Victor LM-2335/LSC-2335

SOMETHING NEW—The Beatles—Capitol T-2108/ST-2108

THE BEST OF THE KINGSTON TRIO—Capitol T-1705, 2280/ST-1705, 2280

UNFORGETTABLE—Nat King Cole—Capitol T-357/DT-357

RAMBLIN'—New Christy Minstrels—Columbia CL-2055/CS-8855

THE BARBRA STREISAND ALBUM—Columbia CL-2007/CS-8807

FUNNY GIRL—Original Cast—Capitol VAS-2059/SVAS-2059

JOHNNY HORTON'S GREATEST HITS—Columbia CL-1596/CS-8396

COTTON CANDY—Al Hirt—RCA Victor LPM-2917/LSP-2917

THE ANDY WILLIAMS CHRISTMAS ALBUM—Columbia CL-2087/CS-8887

CALL ME IRRESPONSIBLE—Andy Williams—Columbia CL-2171/CS-8971

MY FAIR LADY—Soundtrack—Columbia KOL-8000/KOS-2600

BEATLES '65—Capitol T-2228/ST-2228

THE BEATLES STORY—Capitol TBO-2222/STBO-2222

MARY POPPINS—Soundtrack—Vista 4026/S-4026

1965

GLAD ALL OVER—Dave Clark Five—Epic LN-24093/BN-26093

PETER, PAUL & MARY IN CONCERT—Warner Bros. 1555/S-1555

EVERYBODY LOVES SOMEBODY—Dean Martin—Reprise R-6130/RS-6130

WONDERLAND OF GOLDEN HITS—Andre Kostelanetz—Columbia CL-2039/CS-8839

BARBRA STREISAND/THE THIRD ALBUM—Columbia CL-2154/CS-8954

RING OF FIRE—Johnny Cash—Columbia CL-2053/CS-8853

BEACH BOYS IN CONCERT—Capitol TAO-2198/STAO-2198

ALL SUMMER LONG—Beach Boys—Capitol T-2110/ST-2110

SUGAR LIPS—Al Hirt—RCA Victor LPM-2965/LSP-2965

PEOPLE—Barbra Streisand—Columbia CL-2215/CS-9015

THE SOUND OF MUSIC—Soundtrack—RCA Victor LOCD-2005/LSOD-2005

TRINI LOPEZ AT P.J.'S—Reprise R-6093/RS-6093

GETZ/GILBERTO—Stan Getz—MGM/Verve 8545/68545

BEATLES VI—Capitol T-2358/ST-2358

DEAR HEART—Andy Williams—Columbia CL 2338/CS 9138

GOOD TIMES AHEAD FOR GLENN

Thanks to the disc jockeys across the country who have made
GLENN YARBROUGH's RCA Victor albums and singles such
outstanding hits, Glenn's future couldn't be brighter.

RCA VICTOR SINGLES: "Baby the Rain Must Fall"
"It's Gonna Be Fine"

RCA VICTOR ALBUMS: "Time to Move On"
"One More Round"
"Come Share My Life"
"Baby the Rain Must Fall"

TELEVISION APPEARANCES: "The Danny Kaye Show"—September 29

PERSONAL APPEARANCES: A tour of 50 college concerts set for the Fall

COMMERCIALS: Coca Cola — Folger's Coffee — Bosco —
Italian Swiss Colony Wine — Ken-L-Ration



PERSONAL MANAGEMENT

KRAGEN/
CARROLL,
INC.



RCA VICTOR

ita

INTERNATIONAL
TALENT
ASSOCIATES

MILLION-SELLERS

SINGLES THAT HAVE SOLD A MILLION OR MORE COPIES

*SIGNIFIES RIAA-CERTIFIED MILLION SELLERS

Ames Brothers	Sentimental Me (Rag Mop)	Coral 1950
	You You You	Victor 1953
Anderson, Leroy	Blue Tango	Decca 1951
Andrews Sisters	Rum And Coca-Cola	Decca 1944
	I Can Dream, Can't I	Decca 1949
Anka, Paul	Diana	ABC Par 1957
	Lonely Boy	ABC Par 1960
Austin, Gene	Ramona	Victor 1928
Autry, Gene	Silver Haired Daddy	Columbia 1939
	Rudolph The Red-Nosed Reindeer	Columbia 1950
Avalon, Frankie	Venus	Chancellor 1958
Baker, LaVern	I Cried A Tear	Atlantic 1959
Barber, Chris	Petite Fleur	Laurie 1959
Barron, Blue	Cruising Down The River	MGM 1949
Barton, Eileen	If I Knew You Were Comin' I'd Of Baked A Cake	National 1950
Baxter, Les	Poor People Of Paris	Capitol 1956
Beatles	*I Want To Hold Your Hand	Capitol 1964
	*Can't Buy Me Love	Capitol 1964
	She Loves You	Swan 1964
	*A Hard Day's Night	Capitol 1964
	*I Feel Fine	Capitol 1964
Bennett, Tony	Because Of You	Columbia 1952
	Cold Cold Heart	Columbia 1952
	Rags To Riches	Columbia 1953
	Stranger In Paradise	Columbia 1954
Benton, Brook	It's Just A Matter Of Time	Mercury 1959
Bilk, Mr. Acker	Stranger On The Shore	Atco 1962
Black's Combo, Bill	Smokie	Hi 1959
	White Silver Sands	Hi 1960
	Josephine	Hi 1960
Black, Jeanne	He'll Have To Stay	Capitol 1960
Bonds, Gary U. S.	Quarter To Three	Legrand 1962
Booker T & MG's	Green Onions	Stax 1962
Boone, Pat	Ain't That A Shame	Dot 1955
	I'll Be Home	Dot
	Friendly Persuasion	Dot
	Remember You're Mine	Dot
	I Almost Lost My Mind	Dot 1956
	Love Letters In The Sand	Dot 1957
	Don't Forbid Me	Dot 1957
	Why, Baby, Why	Dot 1957
	April Love	Dot 1958
Boyd, Jimmy	I Saw Mommy Kissing Santa Claus	Columbia 1952
Brewer, Teresa	Till I Waltz Again With You	Coral 1952
	Ricochet	Coral 1953

Britt, Elton	There's A Star-Spangled Banner	Victor 1942
	Waving Somewhere	Columbia 1945
Brown, Les	Sentimental Journey	Victor 1959
Browns	Three Bells	Luniverse 1956
Buchanan & Goodman	Flying Saucer	Warner Bros. 1959
Byrnes, Edd	Kookie Lend Me Your Comb	Columbia 1939
Calloway, Cab	Jumpin' Jive	Smash 1962
Channel, Bruce	Hey Baby	Swan 1959
Cannon, Freddie	Way Down Yonder In New Orleans	Decca 1945
Cavallaro, Carmen	Polonaise (by Chopin)	Challenge 1958
Champs	Tequila	ABC Par 1962
Charles, Ray	*I Can't Stop Loving You	Parkway 1960
Checker, Chubby	The Twist	Parkway 1961
	Let's Twist Again	Parkway 1962
	Limbo Rock/Popeye	Cadence 1954
Chordettes	Mr. Sandman	Warner Bros. 1965
Clark, Petula	Downtown	Columbia 1951
Clooney, Rosemary	Come On-A My House	Columbia 1954
	Hey There	Atco 1957
Coasters	Searchin'	Atco 1958
	Yakety Yak	Atco 1959
	Charlie Brown	Atco 1959
	Poison Ivy	Love 1958
Cole, Cozy	Topsy (Part II)	Capitol 1948
Cole, Nat "King"	Nature Boy	Capitol 1949
	Mona Lisa	Capitol 1951
	Too Young	Capitol 1962
Como, Perry	Ramblin' Rose	Victor 1945
	Temptation	Victor 1945
	Hubba Hubba	Victor 1945
	Till The End Of Time	Victor 1946
	Prisoner Of Love	Victor 1947
	When You Were Sweet Sixteen	Victor 1948
	Because	Victor 1952
	Don't Let The Stars Get In	Victor 1954
	Your Eyes	Victor 1956
	Wanted	Victor 1956
	Hot Diggity	Victor 1956
	Papa Loves Mambo	Victor 1957
	Round And Round	Victor 1958
	*Catch A Falling Star	Gordy 1962
	Do You Love Me	Keen 1958
	You Send Me	Decca 1958
Contours	Tea For Two Cha Cha	1961
Cooke, Sam	Last Date	Mercury 1954
Covington, Warren	Sh-Boom	Brunswick 1957
Cramer, Floyd	That'll Be The Day	Decca 1942
Crew Cuts	Silent Night	Decca 1943
Crickets	Sunday, Monday, Or Always	Decca 1943
Crosby, Bing	I'll Be Home For Christmas	Decca 1944
	Swinging On A Star	Decca 1944
	Too-Ra-Loo-Ra-Loo-Ral	Decca 1945
	I Can't Begin To Tell You	Decca 1946
	Dear Hearts And Gentle People	Decca 1946
	New San Antonio Rose	Decca 1946

(Continued on next page)

Johnny Mathis *Patsy Cline* *Jack Jones* *Sammy Davis Jr* *Phantom Foley* *Johnny Rivers*
Sammy Davis Jr *Kai Whang* *Les Baxter* *Minnie Pearl* *Hank Lock*
Lightnin' Hopkins *Nelson Riddle* *Les Baxter* *Webb Pierce*
Stets McDonald *Jimmy Smith* *Ray Bohr*
Jerry Luttrell *Charles Ryan* *Wally Fowler*
Johnny Ray *Ray Allen*

**We've got dozens
of famous recording artists
nobody ever heard of...**

MILLION-SELLERS

Crosby, Bing (Cont'd)	MacNamara's Band Sweet Leilani White Christmas Now Is The Hour Galway Bay	Decca 1946 Decca 1946 Decca 1946 Decca 1948 Decca 1948	Dorsey, Jimmy	Maria Elena Green Eyes So Rare Marie Boogie Woogie There Are Such Things Gambler's Guitar There Goes My Baby True Love, True Love/Dance With Me Save The Last Dance For Me Duke Of Earl	Decca 1946 Decca 1946 Decca 1946 Decca 1948 Decca 1943 Decca 1943 Decca 1944 Decca 1946 Decca 1950 Capitol 1957 Decca 1950	Dorsey, Tommy	I Apologize It's All In The Game Little Star The Loco-Motion Bye Bye Love Wake Up Little Susie All I Have To Do Is Dream Bird Dog/Devoted To You Cathy's Clown	Decca 1946 Decca 1946 Fraternity 1957 Victor 1937 Victor 1938 Victor 1942 Mercury 1953 Atlantic 1960 Atlantic 1960
with Andrews Sisters	Pistol Packin' Mama Jingle Bells Don't Fence Me In South America, Take It Away Play A Simple Melody True Love Whiffenpoof Song	Decca 1943 Decca 1943 Decca 1944 Decca 1946 Decca 1950 Capitol 1957 Decca 1950	Duke Of Earl	Alley Cat The Song From Moulin Rouge *Theme From A Summer Place	Victor 1924 Mercury 1949 ABC-Par 1958 Atco 1958 Atco 1959 Atco 1959 Atco 1960 Class 1958 Columbia 1954 Columbia 1956 Columbia 1961 Roulette 1961 Dot 1957 Liberty 1959 Mercury 1957 Mercury 1958 MGM 1960 Laurie 1961 King 1956 Imperial 1948 Imperial 1952 Imperial 1953 Imperial 1953 Imperial 1953 Imperial 1954 Imperial 1955 Imperial 1955 Imperial 1955 Imperial 1956 Imperial 1956 Imperial 1956 Imperial 1956 Imperial 1957 Imperial 1957 Imperial 1957 Imperial 1960	Draper, Rusty Drifters	Exodus Jalousie Anytime I'm Walking Behind You Oh My Pappa I Need You Now Into Each Life Some Rain Must Fall	Atlantic 1961 Vee Jay 1962
with Gary Crosby with Grace Kelly with Fred Waring	Prisoner's Song You're Breaking My Heart At The Hop Splish Splash Dream Lover Queen Of The Hop Mack The Knife Rockin' Robin Secret Love Whatever Will Be, Will Be *Big Bad John The Peppermint Twist Come Go With Me Quiet Village Little Darlin' The Stroll Teen Angel Runaround Sue Honky Tonk The Fat Man Goin' Home You Said You Loved Me Please Don't Leave Me Going To The River Love Me All By Myself I Can't Go On Ain't That A Shame I'm In Love Again Bo Weevil Blue Monday Blueberry Hill It's You I Love I'm Walkin' I Still Love You Whole Lotta Lovin'	Victor 1924 Mercury 1949 ABC-Par 1958 Atco 1958 Atco 1959 Atco 1959 Atco 1960 Class 1958 Columbia 1954 Columbia 1956 Columbia 1961 Roulette 1961 Dot 1957 Liberty 1959 Mercury 1957 Mercury 1958 MGM 1960 Laurie 1961 King 1956 Imperial 1948 Imperial 1952 Imperial 1953 Imperial 1953 Imperial 1953 Imperial 1954 Imperial 1955 Imperial 1955 Imperial 1955 Imperial 1956 Imperial 1956 Imperial 1956 Imperial 1956 Imperial 1957 Imperial 1957 Imperial 1957 Imperial 1960	Fabric, Bent Faith, Percy	Exodus Jalousie Anytime I'm Walking Behind You Oh My Pappa I Need You Now Into Each Life Some Rain Must Fall	Victor 1924 Mercury 1949 ABC-Par 1958 Atco 1958 Atco 1959 Atco 1959 Atco 1960 Class 1958 Columbia 1954 Columbia 1956 Columbia 1961 Roulette 1961 Dot 1957 Liberty 1959 Mercury 1957 Mercury 1958 MGM 1960 Laurie 1961 King 1956 Imperial 1948 Imperial 1952 Imperial 1953 Imperial 1953 Imperial 1953 Imperial 1954 Imperial 1955 Imperial 1955 Imperial 1955 Imperial 1956 Imperial 1956 Imperial 1956 Imperial 1956 Imperial 1957 Imperial 1957 Imperial 1957 Imperial 1960	Ferrante & Teicher Fiedler, Arthur Fisher, Eddie	Come Softly To Me Mr. Blue Hearts of Stone Sixteen Tons Tell Me Why Love Is A Many-Splendored Thing Moments To Remember No Not Much Sherry Big Girls Don't Cry *Rag Doll Who's Sorry Now My Happiness Among My Souvenirs Mama/Teddy Everybody's Somebody's Fool/ Jealous Of You Together Many Tears Ago Where The Boys Are St. George And The Dragonet	Atco 1962 Columbia 1953 Columbia 1960 Un. Artists 1961 Victor 1938 Victor 1951 Victor 1953 Victor 1953 Victor 1954
Dalhart, Vernon Damone, Vic Danny & Juniors Darin, Bobby	Prisoner's Song You're Breaking My Heart At The Hop Splish Splash Dream Lover Queen Of The Hop Mack The Knife Rockin' Robin Secret Love Whatever Will Be, Will Be *Big Bad John The Peppermint Twist Come Go With Me Quiet Village Little Darlin' The Stroll Teen Angel Runaround Sue Honky Tonk The Fat Man Goin' Home You Said You Loved Me Please Don't Leave Me Going To The River Love Me All By Myself I Can't Go On Ain't That A Shame I'm In Love Again Bo Weevil Blue Monday Blueberry Hill It's You I Love I'm Walkin' I Still Love You Whole Lotta Lovin'	Victor 1924 Mercury 1949 ABC-Par 1958 Atco 1958 Atco 1959 Atco 1959 Atco 1960 Class 1958 Columbia 1954 Columbia 1956 Columbia 1961 Roulette 1961 Dot 1957 Liberty 1959 Mercury 1957 Mercury 1958 MGM 1960 Laurie 1961 King 1956 Imperial 1948 Imperial 1952 Imperial 1953 Imperial 1953 Imperial 1953 Imperial 1954 Imperial 1955 Imperial 1955 Imperial 1955 Imperial 1956 Imperial 1956 Imperial 1956 Imperial 1956 Imperial 1957 Imperial 1957 Imperial 1957 Imperial 1960	Fitzgerald, Ella & Ink Spots Fleetwoods	Alley Cat The Song From Moulin Rouge *Theme From A Summer Place	Victor 1924 Mercury 1949 ABC-Par 1958 Atco 1958 Atco 1959 Atco 1959 Atco 1960 Class 1958 Columbia 1954 Columbia 1956 Columbia 1961 Roulette 1961 Dot 1957 Liberty 1959 Mercury 1957 Mercury 1958 MGM 1960 Laurie 1961 King 1956 Imperial 1948 Imperial 1952 Imperial 1953 Imperial 1953 Imperial 1953 Imperial 1954 Imperial 1955 Imperial 1955 Imperial 1955 Imperial 1956 Imperial 1956 Imperial 1956 Imperial 1956 Imperial 1957 Imperial 1957 Imperial 1957 Imperial 1960	Fontane Sisters Ford, Tennessee Ernie Four Aces	Who's Sorry Now My Happiness Among My Souvenirs Mama/Teddy Everybody's Somebody's Fool/ Jealous Of You Together Many Tears Ago Where The Boys Are St. George And The Dragonet	Atco 1962 Columbia 1953 Columbia 1960 Un. Artists 1961 Victor 1938 Victor 1951 Victor 1953 Victor 1953 Victor 1954
Day, Bobby Day, Doris	Prisoner's Song You're Breaking My Heart At The Hop Splish Splash Dream Lover Queen Of The Hop Mack The Knife Rockin' Robin Secret Love Whatever Will Be, Will Be *Big Bad John The Peppermint Twist Come Go With Me Quiet Village Little Darlin' The Stroll Teen Angel Runaround Sue Honky Tonk The Fat Man Goin' Home You Said You Loved Me Please Don't Leave Me Going To The River Love Me All By Myself I Can't Go On Ain't That A Shame I'm In Love Again Bo Weevil Blue Monday Blueberry Hill It's You I Love I'm Walkin' I Still Love You Whole Lotta Lovin'	Victor 1924 Mercury 1949 ABC-Par 1958 Atco 1958 Atco 1959 Atco 1959 Atco 1960 Class 1958 Columbia 1954 Columbia 1956 Columbia 1961 Roulette 1961 Dot 1957 Liberty 1959 Mercury 1957 Mercury 1958 MGM 1960 Laurie 1961 King 1956 Imperial 1948 Imperial 1952 Imperial 1953 Imperial 1953 Imperial 1953 Imperial 1954 Imperial 1955 Imperial 1955 Imperial 1955 Imperial 1956 Imperial 1956 Imperial 1956 Imperial 1956 Imperial 1957 Imperial 1957 Imperial 1957 Imperial 1960	Fontane Sisters Ford, Tennessee Ernie Four Aces	Who's Sorry Now My Happiness Among My Souvenirs Mama/Teddy Everybody's Somebody's Fool/ Jealous Of You Together Many Tears Ago Where The Boys Are St. George And The Dragonet	Atco 1962 Columbia 1953 Columbia 1960 Un. Artists 1961 Victor 1938 Victor 1951 Victor 1953 Victor 1953 Victor 1954	Four Lads Four Seasons	St. George And The Dragonet	Atco 1962 Columbia 1953 Columbia 1960 Un. Artists 1961 Victor 1938 Victor 1951 Victor 1953 Victor 1953 Victor 1954
Dean, Jimmy Dee, Joey & Starlites Del-Vikings Denny, Martin Diamonds	Prisoner's Song You're Breaking My Heart At The Hop Splish Splash Dream Lover Queen Of The Hop Mack The Knife Rockin' Robin Secret Love Whatever Will Be, Will Be *Big Bad John The Peppermint Twist Come Go With Me Quiet Village Little Darlin' The Stroll Teen Angel Runaround Sue Honky Tonk The Fat Man Goin' Home You Said You Loved Me Please Don't Leave Me Going To The River Love Me All By Myself I Can't Go On Ain't That A Shame I'm In Love Again Bo Weevil Blue Monday Blueberry Hill It's You I Love I'm Walkin' I Still Love You Whole Lotta Lovin'	Victor 1924 Mercury 1949 ABC-Par 1958 Atco 1958 Atco 1959 Atco 1959 Atco 1960 Class 1958 Columbia 1954 Columbia 1956 Columbia 1961 Roulette 1961 Dot 1957 Liberty 1959 Mercury 1957 Mercury 1958 MGM 1960 Laurie 1961 King 1956 Imperial 1948 Imperial 1952 Imperial 1953 Imperial 1953 Imperial 1953 Imperial 1954 Imperial 1955 Imperial 1955 Imperial 1955 Imperial 1956 Imperial 1956 Imperial 1956 Imperial 1956 Imperial 1957 Imperial 1957 Imperial 1957 Imperial 1960	Francis, Connie	Who's Sorry Now My Happiness Among My Souvenirs Mama/Teddy Everybody's Somebody's Fool/ Jealous Of You Together Many Tears Ago Where The Boys Are St. George And The Dragonet	Victor 1924 Mercury 1949 ABC-Par 1958 Atco 1958 Atco 1959 Atco 1959 Atco 1960 Class 1958 Columbia 1954 Columbia 1956 Columbia 1961 Roulette 1961 Dot 1957 Liberty 1959 Mercury 1957 Mercury 1958 MGM 1960 Laurie 1961 King 1956 Imperial 1948 Imperial 1952 Imperial 1953 Imperial 1953 Imperial 1953 Imperial 1954 Imperial 1955 Imperial 1955 Imperial 1955 Imperial 1956 Imperial 1956 Imperial 1956 Imperial 1956 Imperial 1957 Imperial 1957 Imperial 1957 Imperial 1960	Freberg, Stan	St. George And The Dragonet	Atco 1962 Columbia 1953 Columbia 1960 Un. Artists 1961 Victor 1938 Victor 1951 Victor 1953 Victor 1953 Victor 1954
Dinning, Mark Dion Doggett, Bill Domino, Fats	Prisoner's Song You're Breaking My Heart At The Hop Splish Splash Dream Lover Queen Of The Hop Mack The Knife Rockin' Robin Secret Love Whatever Will Be, Will Be *Big Bad John The Peppermint Twist Come Go With Me Quiet Village Little Darlin' The Stroll Teen Angel Runaround Sue Honky Tonk The Fat Man Goin' Home You Said You Loved Me Please Don't Leave Me Going To The River Love Me All By Myself I Can't Go On Ain't That A Shame I'm In Love Again Bo Weevil Blue Monday Blueberry Hill It's You I Love I'm Walkin' I Still Love You Whole Lotta Lovin'	Victor 1924 Mercury 1949 ABC-Par 1958 Atco 1958 Atco 1959 Atco 1959 Atco 1960 Class 1958 Columbia 1954 Columbia 1956 Columbia 1961 Roulette 1961 Dot 1957 Liberty 1959 Mercury 1957 Mercury 1958 MGM 1960 Laurie 1961 King 1956 Imperial 1948 Imperial 1952 Imperial 1953 Imperial 1953 Imperial 1953 Imperial 1954 Imperial 1955 Imperial 1955 Imperial 1955 Imperial 1956 Imperial 1956 Imperial 1956 Imperial 1956 Imperial 1957 Imperial 1957 Imperial 1957 Imperial 1960	Freberg, Stan	St. George And The Dragonet	Victor 1924 Mercury 1949 ABC-Par 1958 Atco 1958 Atco 1959 Atco 1959 Atco 1960 Class 1958 Columbia 1954 Columbia 1956 Columbia 1961 Roulette 1961 Dot 1957 Liberty 1959 Mercury 1957 Mercury 1958 MGM 1960 Laurie 1961 King 1956 Imperial 1948 Imperial 1952 Imperial 1953 Imperial 1953 Imperial 1953 Imperial 1954 Imperial 1955 Imperial 1955 Imperial 1955 Imperial 1956 Imperial 1956 Imperial 1956 Imperial 1956 Imperial 1957 Imperial 1957 Imperial 1957 Imperial 1960	Freberg, Stan	St. George And The Dragonet	Atco 1962 Columbia 1953 Columbia 1960 Un. Artists 1961 Victor 1938 Victor 1951 Victor 1953 Victor 1953 Victor 1954

What are these names doing on \$2. records? The same thing they do on \$3.98 records.

Belting out great pop hits. Blowing, strumming and stomping jazz classics and country and western favorites. Giving new life to symphonic classics.

Here's what Pickwick/33's are all about.

We've taken big names, the ones that normally sell for \$3.98 and put them on \$2. records.

Names like Sammy Davis, Jr., Jack Jones, Johnny Rivers, Pete Fountain, Nelson Riddle, Billy May, Della Reese; country and western stars like Johnny Cash,

Patsy Cline, Johnny Horton, Faron Young, classical artists like Leinsdorf, Steinberg, Milstein and Firkusny; and the exciting Parris Mitchell Strings and Voices.

Incidentally, our recording stars are not just making guest appearances on our albums. When it says Sammy Davis, every band is a Sammy Davis selection.

Since we've got \$3.98 recording stars, we've given them \$3.98 sound reproduction. Tap quality pure vinyl pressings.

And Pickwick packaging would stand up to any around. Striking full-color designs, on high-embossed stock, and

wrap-around jackets. We've even added an exclusive "Pinch Back Spine" for convenient stacking.

All of which makes Pickwick/33 a unique recording label.

It's a line of \$2. records of such high performance and quality level that \$2. is a pre-discounted selling price. (Our classical Pickwick/33 line is priced at \$2.50, monaural or stereo.)

Which means Pickwick/33 gives you a high turnover line plus something you've never gotten in a \$2. record—or in many \$3.98 records.

Profit.

Call or write your own local distributor or Pickwick International, Pickwick Bldg., L.I.C., N.Y. 11101. Code 212-EM 1-8811.



on a \$2.00 record.

MILLION-SELLERS

Complete Childrens Catalog at 29¢ and \$1.98.

SIMON SAYS

ARC
A full line of International Favorites

CABOT and GATEWAY
Language Series

COSMO RECORDING CO.
33-49 WHELAN ROAD, EAST RUTHERFORD, N.J.
JERSEY/AREA 201-933-8300 NEW YORK/AREA 212-279-9980

NATIONAL TALENT CONSULTANTS

proudly represents
the following writers and performers

Harry Betts
Raquel Welch
Mike Post
Dick St. John
Ulle Tett
Michael Blodgett

The Rising Sons
Wendy Hill
Jimmy Cameron
Donnie Brooks
Roger Christian
The Bats

Current films in release and production

"A SWINGIN' SUMMER" — 1965

"The Mild Assassin or The Private World Of Stanley Butcher"—1966

Current copyrights—Empty Sea (BMI)
Mirich (ASCAP)

"Cryin' Blues"—Righteous Bros.

"Orleans Bound"—Mike Post

"No Matter What You Do"—Lesley Gore

"Be My Man"—Jody Miller

"I've Cried Before"—Dick St. John

"When's It Gonna Be My Turn"—Serendipity Singers—Settlers

"Penny The Poo"—Donnie Brooks

Motion Picture Score to "A Swingin' Summer" released by
Hanna-Barbera Records

Exclusive Producer of Radio Commercials for Yamaha Motorcycles
and syndicated Roger Christian T.V. Color Show "Big Beat"

NATIONAL TALENT CONSULTANTS

Ken Raphael—Larry Goldblatt

Howard Wolfe—Associate

John Dugan Agency—Production Co. Rep.

144 S. Beverly Drive
Beverly Hills, Calif. 213-Cr-3-4404

Gibbs, Georgia	Kiss Of Fire Tweedle Dee Dance With Me Henry *Sugar Shack	Mercury 1952 Mercury 1955 Mercury 1955 Dot 1963
Gilmer, Jimmy & Fireballs Glahe, Will Gleason, Jackie Godfrey, Arthur Grant, Gogi	Beer Barrel Polka Melancholy Serenade Too Fat Polka Suddenly There's A Valley Wayward Wind Shake, Rattle And Roll Rock Around The Clock A Rose And A Baby Ruth The Thing Kansas City Davy Crockett You'll Never Know Little White Lies Deep In The Heart Of Texas My Special Angel Laura Woodchopper's Ball Mrs. Brown You've Got A Lovely Daughter	Victor 1938 Capitol 1953 Columbia 1947 Era 1955 Era 1956 Decca 1955 Decca 1955 ABC-Par 1958 Victor 1950 Fury 1959 Cadence 1955 Decca 1943 Decca 1948 Columbia 1941 Decca 1957 Columbia 1945 Decca 1947
Haley, Bill	Michael	MGM 1965 United Artists 1961 Dot
Hamilton IV, George Harris, Phil Harrison, Wilbert Hayes, Bill Haymes, Dick	P.S. I Love You Paggy Sue Alley-Oop Battle Of New Orleans To Each His Own 12th Street Rag Oh Young Love Itsy Bitsy Teenie Bikini	Coral 1958 Lute 1960 Columbia 1959 Mercury 1946 Capital 1951 Capitol 1953 Dot 1957 Kapp 1960
Heidt, Horace Helms, Bobby Herman, Woody	Herman's Hermits	Cub 1959 Decca 1946 Decca 1946
Hunter, Tab Hyland, Brian	Highwaymen Hilltoppers Holly, Buddy Hollywood Argyles Horton, Johnny Howard, Eddy Hunt, Pee Wee	
Impalas Ink Spots	Sorry (I Ran All The Way Home) To Each His Own The Gypsy	
James, Harry	Ciribiribin One O'Clock Jump You Made Me Love You	Columbia 1939 Columbia 1941 Columbia 1946
James, Joni	Why Don't You Believe Me Your Cheating Heart Have You Heard	MGM 1953 MGM 1953
James, Sonny Jenkins, Gordon with The Weavers Jolson, Al	Young Love Maybe You'll Be There Goodnight, Irene April Showers b/w Swanee California Here I Come b/w Rockabye Your Baby You Made Me Love You b/w Ma Blushin' Rosie Sonny Boy b/w My Mammy Anniversary Song	Capitol 1957 Decca 1947 Decca 1950 Decca 1945
Jones, Jimmy	Handy Man Good Timin'	Decca 1946 Decca 1946 Decca 1946
Jones, Spike	Cocktails For Two All I Want For Christmas	Cub 1960 Cub 1960
Jordan, Louis Justis, Bill	Choo Cho Ch'Boogie Raunchy	Victor 1944 Victor 1948 Decca 1946 Phillips Int 1958
Kaempfert, Bert Kalin Twins Kallen, Kitty King, Claude King, Pee Wee Kingston Trio Knight, Evelyn Kyser, Kay	Wonderland By Night When Little Things Mean A Lot Wolverton Mountain Slow Poke *Tom Doolley A Little Bird Told Me Three Little Fishes Jingle Jangle Jingle Praise The Lord Strip Polka Who Wouldn't Love You Woody Woodpecker	Decca 1961 Decca 1958 Decca 1954 Columbia 1962 Victor 1951 Capitol 1958 Decca 1948 Columbia 1941 Columbia 1942 Columbia 1942 Columbia 1942 Columbia 1942 Columbia 1948
Laine, Frankie	That's My Desire Shine Mule Train Lucky Ol' Sun Jezebel I Believe Moonlight Gambler Eh Cumpari Be My Love Loveliest Night of the Year Go Away Little Girl I'm Sorry/That's All You Gotta Do Manana Rock-A-Bye Your Baby With A Dixie Melody	Mercury 1947 Mercury 1948 Mercury 1949 Mercury 1949 Columbia 1951 Columbia 1953 Columbia 1957 Cadence 1953 Victor 1950 Victor 1951 Columbia 1963 Decca 1960 Capitol 1948
La Rosa, Julius Lanza, Mario	Great Balls Of Fire Whole Lot of Shakin' Going On	Decca 1956 Sun 1957 Sun 1958
Lawrence, Steve Lee, Brenda Lee, Peggy Lewis, Jerry	Third Man Theme Humoresque Easter Parade	Decca 1944 Decca 1946 Decca 1947
Lewis, Jerry Lee	with Andrews Sisters Christmas Island	Decca 1946
Lombardo, Guy		

(Continued on next page)

MILLION-SELLERS

London, Julie	Cry Me A River	Liberty 1955	Monte, Lou	Pepino	Reprise 1963
London, Laurie	*He's Got The Whole World	Capitol 1958	Mooney, Art	Four Leaf Clover	MGM 1948
Long, Johnny	Shanty Town	Decca 1940	Morgan, Russ	Cruising Down The River	Decca 1949
Lowe, Jim	Green Door	Dot 1957	Morse, Ella Mae	Blacksmith Blues	Decca 1952
Luke, Robin	Susie Darlin'	Dot 1958	McCoy, Clyde	Sugar Blues	Decca 1946
Lund, Art	Mam'selle	MGM 1947	Nelson, Ricky	Teenager's Romance	Verve 1957
Lynn, Vera	Auf Weidersehn	London 1955		Stood Up	Imperial 1957
Maddox, Johnny	Crazy Otto	Dot		Be Bop Baby	Imperial 1958
Mangano, Sylvana	Anna	MGM 1953		Poor Little Fool/Lonesome Town	Imperial 1958
Marterie, Ralph	Caravan	Mercury 1952		Believe What I Say	Imperial 1958
	Pretend	Mercury 1953		It's Late/Never Be Anyone Else	
Martin, Dean	That's Amore	Capitol 1953		But You	Imperial 1959
	Memories Are Made Of This	Capitol 1955		Travelin' Man/Hello Mary Lou	Imperial 1961
	*Everybody Loves Somebody	Capitol 1964	Orbison, Roy	Only The Lonely	Monument 1960
Martin, Freddy	Piano Concerto in B Flat	Victor 1941		*Oh, Pretty Woman	Monument 1964
	White Christmas	Victor 1942			
Martindale, Wink	Deck Of Cards	Dot 1960	Page, Patti		
Marvelettes	Please Mr. Postman	Tamla 1960		Tennessee Waltz	Mercury 1950
Mathis, Johnny	Chances Are	Columbia 1957		Mockingbird Hill	Mercury 1950
	It's Not For Me To Say	Columbia 1957		I Went To Your Wedding	Mercury 1952
McGuire, Sisters	Sincerely	Coral 1955		Doggie in the Window	Mercury 1952
	Sugartime	Coral 1958		Changing Partners	Mercury 1953
McPhatter, Clyde	A Lover's Question	Atlantic 1958		Cross Over the Bridge	Mercury 1954
Miller, Glenn	American Patrol	Victor 1939	Patience & Prudence	Allegheny Moon	Mercury 1956
	In The Mood	Victor 1939	Paul & Paula	Tonight You Belong To Me	Liberty 1956
	Little Brown Jug	Victor 1939	Paul, Les &	*Hey Paula	Philips 1960
	Sunrise Serenade	Victor 1939	Mary Ford	How High The Moon	Capitol 1947
	Pennsylvania 6-5000	Victor 1940		Mockin' Bird Hill	Capitol 1949
	Tuxedo Junction	Victor 1940		The World Is Waiting For the	
	Chattanooga Choo Choo	Victor 1941		Sunrise	Capitol 1949
	Kalamazoo	Victor 1942	Penguins	Vaya Con Dios	Capitol 1953
Miller, Mitch	Yellow Rose Of Texas	Columbia 1955	Phillips, Phil	Earth Angel	Dooto 1957
Miller, Roger	*King Of The Road	Smash 1965		Sea Of Love	Mercury 1959
Mills Brothers	You Always Hurt The One You Love	Decca 1944	Pickett, Bobby	Monster Mash	Garpax 1962
	Paper Doll	Decca 1948	Platters	Only You	Mercury 1955
	The Glow-Worm	Decca 1952		The Great Pretender	Mercury 1955
Mitchell, Guy	My Heart Cries For You	Columbia 1950		My Prayer	Mercury 1956
	Singing The Blues	Columbia 1957		Twilight Time	Mercury 1958
Modugno, Domenico	Nel Blu Dipinto Di Blu (Volare)	Decca 1958	Playmates	Smoke Gets In Your Eyes	Mercury 1959
Monroe, Vaughn	Racing With the Moon	Victor 1941	Prado, Perez	Beep Beep	Roulette 1958
	There I've Said It Again	Victor 1945		Cherry Pink And Apple Blossom	
	Ballerina	Victor 1947		White	Victor 1955
	Riders In The Sky	Victor 1949	Presley, Elvis	*Patricia	Victor 1958
				Heartbreak Hotel	Victor 1956
				I Want You, I Need You, I Love You	Victor 1956
				Love Me Tender	Victor 1956
				All Shook Up	Victor 1957
				Don't Be Cruel/Hound Dog	Victor 1957
				Too Much	Victor 1957
				Teddy Bear/Loving You	Victor 1957
				Jailhouse Rock	Victor 1957
				Wear My Ring Around Your Neck	Victor 1958
				Don't	Victor 1958
				I Got Stung	Victor 1958
				*Hard Headed Woman	Victor 1958

(Continued on next page)

BEST WISHES ON YOUR 23rd ANNIVERSARY

Billy Sherman

Budd Dolinger



Barry DeVorzon

Bodie Chandler

Billy Sherman Barry DeVorzon Budd Dolinger
Bodie Chandler Kelly Gordon

VALIANT RECORDS, INC. / 6290 SUNSET BOULEVARD
HOLLYWOOD, CALIF. 90028 / HOLLYWOOD 4-8144

#1 Most Programmed
Orchestra

Many
Thanks

Henry
Mancini

RCA VICTOR

The most trusted name in sound

MILLION-SELLERS

Presley, Elvis (Cont'd)	A Fool Such As I Stuck On You It's Now Or Never Are You Lonesome Tonight Surrender *Can't Help Falling In Love Good Luck Charm Return To Sender	Victor 1959 Victor 1959 Victor 1960 Victor 1960 Victor 1961 Victor 1961 Victor 1962 Victor 1962
Preston, Johnny Price, Lloyd	Running Bear Stagger Lee Personality	Mercury 1960 ABC Par 1959 ABC Par 1959
Ray, Johnnie Rays Reeves, Jim Reynolds, Debbie Riddle, Nelson Rodgers, Jimmie	Cry Silhouettes He'll Have To Go Tammy Lisbon Antigua Honeycomb Kisses Sweeter Than Wine Secretly Oh-Oh I'm Falling In Love Again *Satisfaction Walk Right In The Stripper Wild One/Little Bitty Girl	Columbia 1951 Cameo 1958 Victor 1960 Coral 1957 Capitol 1955 Roulette 1957 Roulette 1958 Roulette 1958 Roulette 1958 London 1965 Vanguard 1963 MGM 1962 Cameo 1959
Rolling Stones Rooftop Singers Rose, David Rydell, Bobby		
Sakamoto, Kyu Sam The Sham & The Pharoahs Sands, Tommy Santo & Johnny Scott, Jack	Sukiyaki *Wooly Bully Teen Age Crush Sleepwalk My True Love/Leroy What In The World's Come Over You	Capitol 1963 MGM 1965 Capitol 1957 Can-Am 1959 Carlton 1958 Top Rank 1960
Seville, David	Witch Doctor Chipmunk Song Alvin's Harmonica	Liberty 1958 Liberty 1958 Liberty 1959
Shannon, Del Sharp, Dee Dee Shaw, Artie	Runaway Mashed Potato Time Begin The Beguine Star Dust Summit Ridge Drive	Bigtop 1961 Cameo 1962 Victor 1938 Victor 1940 Victor 1940
Shirelles Shore, Dinah Silhouettes Sinatra, Frank Smith, Kate Stafford, Jo	Soldier Boy Buttons And Bows Get A Job Young At Heart Rose O'Day Temptation Make Love To Me	Scepter 1962 Columbia 1948 Ember 1958 Capitol 1954 Columbia 1941 Capitol 1948 Columbia 1954
Standley, Johnny Starr, Kay	It's In The Book Wheel Of Fortune Rock And Roll Waltz	Capitol Capitol 1952 RCA Victor 1955
Stevens, Dodie Stoloff, Morris Storm, Gale	Pink Shoelaces Moonglow & Picnic Theme I Hear You Knockin' To Know Him Is To Love Him	Crystalette 1958 Decca 1956 Dot Dore 1958
Todd, Art & Dotty Tokens Tucker, Orrin Twitty, Conway	Chanson D'Amour *The Lion Sleeps Tonight Oh, Johnny It's Only Make Believe Lonely Blue Boy	Era 1957 Victor 1961 Columbia 1939 MGM 1958 MGM 1960
Valens, Ritchie Vaughn, Billy	Donna Melody Of Love Sail Along Silv'ry Moon	Del-Fi 1958 Dot 1956 Dot 1957
Vaughan, Sarah Vee, Bobby Vinton, Bobby	Broken Hearted Melody Take Good Care Of My Baby *Roses Are Red	Mercury 1959 Liberty 1961 Epic 1962
Wallace, Jerry Ward, Billy Waring, Fred Washington, Dinah & Benton, Brook	Primrose Lane Stardust 'Twas The Night Before Christmas Baby (You Got What It Takes)	Challenge 1960 Liberty 1957 Decca 1942 Mercury 1960
Weavers, The Weber, Joan Weems, Ted Welk, Lawrence Whiteman, Paul	On Top Of Old Smoky Let Me Go Lover Heartaches *Calcutta Whispering Three O'Clock In The Morning	Decca 1951 Columbia 1954 Decca 1950 Dot 1961 Victor 1920 Victor 1922
Whitfield, David Whiting, Maggie with Jimmy Wakely Whitman, Slim	Cara Mia The Tree In The Meadow Slipping Around Indian Love Call Secret Love Rose Marie	London 1956 Capitol 1948 Capitol 1949 Imperial 1951 Imperial 1953 Imperial 1954
Williams, Billy Williams, Roger Williams, Tex Willis, Chuck Wilson, Jackie Winterhalter, Hugo Wooley, Sheb	I'm Gonna Sit Right Down Autumn Leaves Smoke, Smoke, Smoke What Am I Living For Night/Doggin' Around Canadian Sunset Purple People Eater	Coral 1957 Kapp 1955 Capitol Atlantic 1958 Brunswick 1960 Victor 1956 MGM 1958



PROUDLY PRESENTS

WORLD WIDE BEST SELLING ORIGINAL SOUNDTRACK ALBUMS

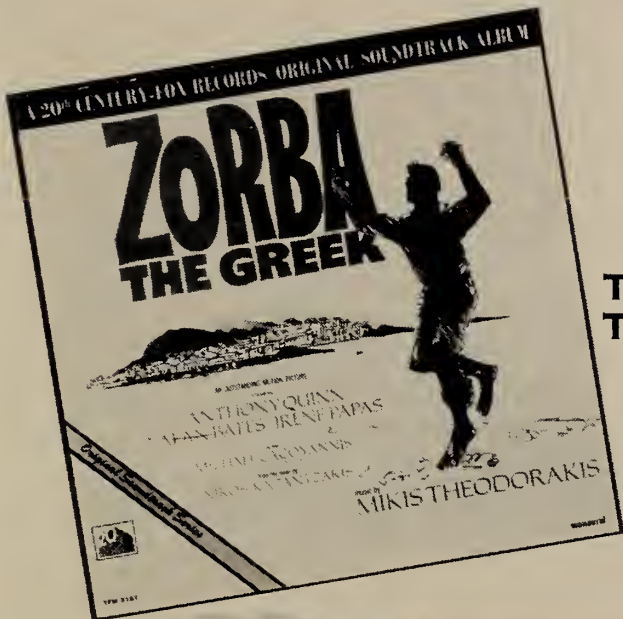

TFM 3167 (MONAURAL)
TFS 4167 (STEREO)

TFM 3174 (MONAURAL)
TFS 4174 (STEREO)



JUST RELEASED

2 BRAND NEW SMASH SINGLES

MARY WELLS

"ME WITHOUT YOU" B/W "I'M SORRY" FOX 606

DICKEY LEE

"THE GIRL FROM PEYTON PLACE" TCF 111

SENSATIONAL FOLLOWUP TO "LAURIE"

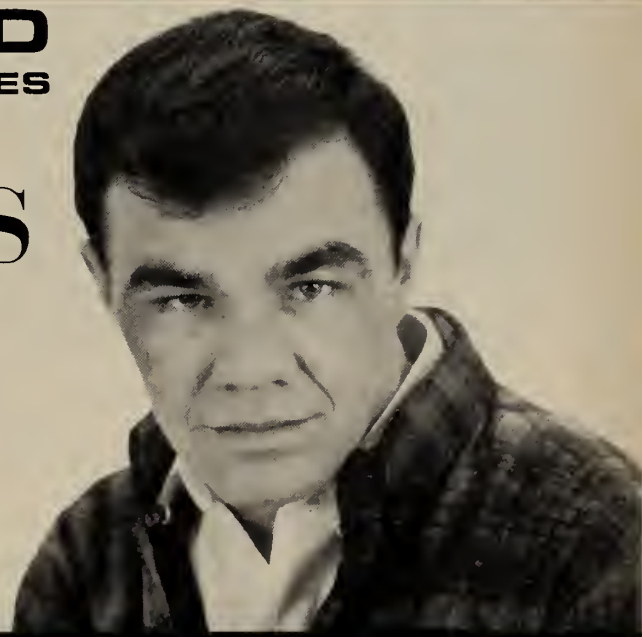

STILL THE BEST-SELLING CHRISTMAS ALBUM AND SINGLE OF ALL-TIME

TFM 3100 (MONAURAL)
TFS 4100 (STEREO)
FOX 429 (SINGLE)



20th CENTURY-FOX RECORDS • 444 WEST 56th • NEW YORK 19, NEW YORK • PRINTED IN U. S. A.



**NEW YORK'S LEADING
WHOLESALE PHONOGRAPH
RECORD DISTRIBUTOR...
DISTRIBUTING
ALL LABELS**

**WIN
RECORDS
INC.**

**CONTACT US FOR
INCREASE IN PROFIT
THROUGH OUR RACK
MERCHANDISING PLAN . . .**

**CALL — WIRE — WRITE
SAM WEISS and GEORGE WEISS
WIN RECORDS, INC.**

**858 Ninth Ave., New York, N. Y.
JU 2-0130**

SUDDEN SERVICE

MUSICAL SALES ONE STOP

**134-136 W. MT. ROYAL AVE.
BALTIMORE, MD. 21201
Phone: VErnon 7-5757**

**JOE "ROUND MAN" SADLER
CLIFF CAR
Sales**

**MILT BERESON
President**

NEW JERSEY ONE STOP CORP.

- **BEST PRICES**
- **BEST SERVICES**
- **COMPLETE INVENTORY**

347 Washington St.

Newark, N. J.

(Tel. 201-642-0115)

JOE MARTIN, Pres.

RED KRAEMER, Mgr.

ONE STOPS

● Member of ROSA

ALABAMA

M&F Record Suppliers
1630 6th North
Birmingham, Ala.

Music Center
416 N. 19th St.
Birmingham, Ala.

Victory One Stop
805 9th Court
Birmingham, Ala.

Record Shop
212 Johnston St., E.
Decatur, Ala.

The Record Shop
107 N. Side Square
Huntsville, Ala.

The Record Shop Annex
11A Parkway City
Huntsville, Ala.

Prichard Music & Appl.
112 Main St.
Prichard, Ala.

ARIZONA

Arizona M. B. Krupp
2519 N. 16th St.
Phoenix, Ariz.

Flash Dist.
3121 E. McDowell
Phoenix, Ariz.

ARKANSAS

Moses Melody
505 Main St.
Little Rock, Ark.

CALIFORNIA

Western
1461 Park Avenue
Emeryville, Calif.

California Music
2933 W. Pico Blvd.
Los Angeles, Calif.

Disc Mobile
2567 W. Pico Blvd.
Los Angeles, Calif.

Norty's
436 N. Fairfax Ave.
Los Angeles, Calif.

Sun State Dist.
2669 W. Pico Blvd.
Los Angeles, Calif.

Dale Record Service
2940 W. Pico Blvd.
Los Angeles, Calif.

Luenhagen
2277 W. Pico Blvd.
Los Angeles, Calif.

Op's One Stop
2647 W. Pico Blvd.
Los Angeles, Calif.

Tower Records
1518 Broadway
Sacramento, Calif.

M. T. S., Inc.
1518 Broadway
Sacramento, Calif.

Bravoff Piano & Music
1170 "E" St.
San Bernardino, Calif.

Dial Sales
1835 Fifth St.
San Diego, Calif.

Hit Line Record Sales
3917 Polack St.
San Diego, Calif.

Ratner Elec.
745 Broadway
San Diego, Calif.

Music Box
1070 Howard St.
San Francisco, Calif.

R. F. Jones
240 Shotwell St.
San Francisco, Calif.

Nor Cal One Stop
1175 Howard St.
San Francisco, Calif.

Western
224 Sixth St.
San Francisco, Calif.

COLORADO

J & L Racks
36 S. Sante Fe
Denver, Colo.

● Mountain Distributors
3630 Downing St.
Denver, Colo.

Morton Record Co.
945 E. Evans Ave.
Pueblo, Colo.

Mile Hi One Stop
77 Klamath
Denver, Colo.

Music Box One Stop
1043 Broadway
Denver, Colo.

CONNECTICUT

Central
477 Park Ave.
E. Hartford, Conn.

Globe One Stop
308 Tolland St.
E. Hartford, Conn.

Record & Rack Sales
76½ Tolland St.
E. Hartford, Conn.

Dave's One Stop
171 Park Ave.
E. Hartford, Conn.

Park Dist.
275 Park Ave.
E. Hartford, Conn.

Leslie Dist. N.E.
275 Park Ave.
E. Hartford, Conn.

Cutler's
33 Broadway
New Haven, Conn.

DISTRICT OF COLUMBIA

Supermusic
1245 9th St., N.W.
Washington, D. C.

(Continued on page 105)

**The Most EXPERIENCED... AGGRESSIVE
ONE-STOPS
furnish STAR PRINTED TITLE STRIPS**

☆☆☆

MR. OPERATOR — Check with your local One-Stop today or write to us for the name and address of a "STAR SUPPLIED" One-Stop near you.

★

STAR TITLE STRIP COMPANY, INC.

842 Western Avenue Area Code 412 231-4314 Pittsburgh, Pa. 15233

ONE STOPS

Quality Music
1836 7th St., N.W.
Washington, D. C.

FLORIDA

•Southern Record Service
1020 E. 14th St.
Hialeah, Fla.

•Budisco Record Sales
60 Riverside Ave.
Jacksonville, Fla.

Budisco, Inc.
236 N.W. 29th St.
Miami, Fla.

Jet
4928 N.W. 7th Ave.
Miami, Fla.

Sunshine State Record Dist.
8170 N.W. 36th Ave.
Miami, Fla.

Ernie Reyer
2815 S.W. 63rd Ave.
Miami, Fla.

Southland Appl.
1664 N.W. 36th St.
Miami, Fla.

H & L Record Mart
66 W. Church St.
Orlando, Fla.

Record Supply Co.
720 Franklin St.
Orlando, Fla.

Southern Music
503 W. Central
Orlando, Fla.

Courts
P. O. Box 12856
St. Petersburg, Fla.

Budisco Record Service
1723 Cypress
Tampa, Fla.

Columbia Music
1416 E. Broadway
Tampa, Fla.

Gallop Records
1416 E. Broadway
Tampa, Fla.

GEORGIA

All Purpose Service
1456 Northside Dr., N.W.
Atlanta, Ga.

L & F
1227 Spring St., N.W.
Atlanta, Ga.

The Music Pit
4 Broad St., S.W.
Atlanta, Ga.

Gate City Record Serv
1209 Techwood Dr.
Atlanta, Ga.

Music Box One Stop
1360 Spring St., N.W.
Atlanta, Ga.

Record Center
2581 Piedmont Rd., N.E.
Atlanta, Ga.

Clarksville Record Sales
P. O. Box 198, Washington St.
Clarksville, Ga.

Ralph's Radio Music
Hwy. 441—Box 117
Demorest, Ga.

Southeast Record Sales
138 E. 5th St.
Tifton, Ga.

ILLINOIS

ABCO
3313 N. Springfield Ave.
Chicago, Ill.

All Records
3006 N. Elston Ave.
Chicago, Ill.

Galgano
4135 W. Armitage Ave.
Chicago 39, Ill.

Joe's Record Shop
550 E. 43rd St.
Chicago, Ill.

Little Al's
3216 W. Lawrence Ave.
Chicago, Ill.

Lormar Record Dist.
3214 W. Augusta
Chicago, Ill.

Marquette Records
3215 W. 63rd
Chicago, Ill.

Minetts Record Dist.
2029 S. Michigan Ave.
Chicago, Ill.

Music Box
1301 W. 79th St.
Chicago, Ill.

New Deal Record Dist.
1414 S. Michigan Ave.
Chicago, Ill.

Pan American One Stop
1344 S. Halsted St.
Chicago, Ill.

Profit Venders
3216 W. Lawrence
Chicago, Ill.

Record Mart
733 W. 63rd
Chicago, Ill.

Singer
1812 W. Chicago
Chicago, Ill.

World Dist.
2017 S. Michigan
Chicago, Ill.

Decatur Rak Sales
1130 E. Eldorado-312 N. Water
Decatur, Ill.

The Original One Stop
312 N. Water St.
Decatur, Ill.

World Dist.
5531 Morton Grove, Ill.

S & G Music
403 South Adams
Peoria, Ill.

Hi Fi One Stop
804 N. Main St.
Peoria, Ill.

Van Goor
1715 2nd Ave.
Rock Island, Ill.

Platter Record Shop
208 S. 4th St.
Springfield, Ill.

INDIANA

Associated Dist.
210 S. Meridan
Indianapolis, Ind.

C C Record Co. of Indiana
1312 Capitol
Indianapolis, Ind.

Ed Whitehead Enterprises
817 North Fares Ave.
Evansville, Ind.

Klahen's Record Shop
1230 South Anthony
Ft. Wayne, Ind.

J & J Dist. Co.
1661 W. 16 St.
Indianapolis, Ind.

IOWA

Dart Records
515 E. Locust
Des Moines, Iowa

Mars Sales
1630 Locust
Des Moines, Iowa

Lieberman Record One Stop
1406 E. Grand
Des Moines, Iowa

Records, Inc.
315 12th St.
Des Moines, Iowa

(Continued on page 106)



**ON-THE-GO
COAST TO COAST**

**INTERSTATE
RECORD DISTRIBUTORS inc.**

Al Levine, Lou Klayman, Manny Wells

**MOBILE
ONE STOP
ALL LABEL RECORD
SERVICE**

The most Complete, Versatile Distribution Network
• Rack Jobbing • Promotional Records • Surplus Disks •
• Promotion Planning • One-Stop Service
Prompt-As-Promised Delivery
Check the Interstate Distributor nearest you.

**NEW DEAL RECORD
SERVICE CORP.**
182-20 Liberty Ave.
Jamaica, Queens, N.Y. 11412
212-454-1000
Morris Weissman,
Peter Hyman

**NEW DEAL RECORD
SERVICE CORP.**
1414 SOUTH MICHIGAN
CHICAGO, ILLINOIS
Area Code 312-922-6245
Irv Rothblatt

**NEW DEAL RECORD
SERVICE CORP.**
15329 LIVERNOIS AVENUE
DETROIT, MICHIGAN
Area Code 313-863-2226
Dave Lasher

**NEW DEAL RECORD
SERVICE CORP.**
1601 Guilford Ave.
BALTIMORE, MARYLAND
Area Code 301-837-2773
Ronny Bollin

**NEW DEAL RECORD
SERVICE CORP.**
c/o DON FAERBER
4918 PLUM TREE LANE
HAZLEWOOD, MO.
Don Faerber

**NEW DEAL RECORD
SERVICE CORP.**
3660 W. PICO BLVD.
LOS ANGELES, CALIFORNIA
Area Code 213-731-9313
Stan Sterling

**NEW YORK RECORD
DIST. INC.**
182-20 Liberty Ave.
Jamaica, Queens, N.Y. 11412
212-454-1000
Max Goldstein,
Charlie Peters

**GARDEN STATE RECORD
DIST. INC.**
182-20 Liberty Ave.
Jamaica, Queens, N.Y. 11412
212-454-1000
Carl Medici

SUNSHINE STATE RECORD DIST. INC.
8170 N.W. 36 AVENUE
MIAMI, FLORIDA
Area Code 305-696-4951
Morty Marks, Mel Price

**OLDEST & BIGGEST
ONE STOP IN THE
MIDWEST**

"The Original" ONE STOP RECORD SERVICE

- Complete Single and L.P. Inventory
- Regular Wholesale Prices
- Orders Shipped Same Day Received
- Any Mode of Shipping You Name
- Free Title Strips

"The Original" ONE STOP RECORD SERVICE

2721 Pine Street St. Louis 3, Mo. Jefferson 5-4172
3230 Roanoke Rd., Kansas City 11, Mo. Logan 1-8076
312 N. Water St. Decatur, Ill. 428-6653

Write or Call for Details

12

**Years Of Proven Success. Become
Part Of Our Profitable Picture. We
Feature Complete Rack Service, Chain
Stores And Discount Stores Our
Specialty...**

STEADMAN SALES, INC.

140 East 3rd Street Mount Vernon, N. Y.
(914) OW 9-3166

THE MOST COMPLETE ONE STOP & RACK SERVICE!

**GATE CITY
RECORD SERVICE COMPANY**

1209 TECHWOOD DRIVE, N.W., ATLANTA, GEORGIA—873-4384

HERMITAGE MUSIC CO.

**ONE OF THE SOUTH'S
LARGEST**

ONE STOP RECORD SUPPLIERS

469 Chestnut St. Nashville, Tenn.

(615) 244 1790

ONE STOPS

KANSAS

Giant
221 E. Williams
Wichita, Kans.

The Record Shop
221 E. Williams St.
Wichita, Kans.

Pioneer Dist. Co.
2059 S. Kansas Ave.
Wichita, Kans.

Davidson One Stop
1719 S. Hillside
Wichita, Kansas

KENTUCKY

Central Electrns
217 E. First St.
Campbellsville, Ky.

Variety
645 S. 4th St.
Louisville, Ky.

Shivley One Stop
4464 Dixie Hwy.
Louisville, Ky.

•Vine
400 E. Broadway
Louisville, Ky.

Wax Works
320 Washington Ave.
Owensboro, Ky.

LOUISIANA

Record Hdqs.
1810 N. St.
Baton Rouge, La.

Territo's
522 Lafayette St.
Gretna, La.

Staggs Music Shops
1006 Cameron
Lafayette, La.

Gulf States
628 Baronne St.
New Orleans, La.

One Stop Record
330 S. Rampart St.
New Orleans, La.

Stan's Record Shop
728 Texas St.
Shreveport, La.

Floyds Record Shop
Box 506, East Main St.
Ville Platte, La.

MAINE

Viners
20-24 Broad St.
Bangor, Maine

New England Record
212 Anderson St.
Portland, Maine

Boyd Corp.
84 W. Cove St.
Portland, Maine

Portland Record
84 West Cove
Portland, Maine

MARYLAND

•Musical Sales
140 W. Mt. Royal Ave.
Baltimore, Md.

One Stop Record Service
2566 Madison Ave.
Baltimore, Md.

New Deal
1601 Guilford Ave.
Baltimore, Md.

Redisco
1815 Guilford Ave.
Baltimore, Md.

Super Music
570 N. Gay St.
Baltimore, Md.

Wollman Music Store
233 S. Broadway
Baltimore, Md.

MASSACHUSETTS

Boston Record Dist.
150 Vernon St.
Boston, Mass.

Dick's Records
298 Lincoln St.
Boston, Mass.

Dick Records
1355 A. Washington St.
Boston, Mass.

Rec. Wholesalers Of N.E.
1241 Columbus Ave.
Boston, Mass.

Temple Sales
4 Gordon St.
Boston, Mass.

W.S. Music Dist.
126 Lincoln St.
Brighton, Mass.

Somerset Corp.
203 Plymouth Ave.
Fall River, Mass.

Leslie Sales
330 Risinoir St.
Needham Hgts, Mass.

Disco
37 Fremont St.
Somerville, Mass.

One Stop
30 Nashua St.
Woburn, Mass.

MICHIGAN

Lucky's
713 E. Midland St.
Bay City, Michigan

Martin & Snyder
13200 W. Warren
Dearborn, Mich.

Angott Dist. Co.
2616 Puritan Ave.
Detroit, Mich.

New Deal Record Service
15329 Livernois Ave.
Detroit, Mich.

Cadet Dist. Co.
13380 Capitol Ave.
Oak Park (Detroit), Mich.

Consolidated
13254 Linwood Ave.
Detroit, Mich.

State Song Shop
3419 Hastings
Detroit, Mich.

Record City
41 S. Division St.
Grand Rapids, Mich.

Jackson Automatic
643 E. Michigan Ave.
Jackson, Mich.

MINNESOTA

Acme
321 Plymouth Ave., N.
Minneapolis, Minn.

All Records
127 N. 9th St.
Minneapolis, Minn.

Brown Bros.
2321 Washington Ave., N
Minneapolis, Minn.

Dart Records, Inc.
730 N. Lyndale Ave.
Minneapolis, Minn.

Kaybank of Minneapolis
2541 Nicollet Ave.
Minneapolis, Minn.

(Continued on page 107)

ONE STOPS

Rapid Merchandising
8175 Lewis Rd.
Minneapolis, Minn.

Record Service
1913 Plymouth Ave.
Minneapolis, Minn.

Automatic Games Supply
1934 University Ave.
St. Paul, Minn.

Jim's Records
1724 University Ave.
St. Paul, Minn.

LeBeau Novelty Sales
1902 University Ave.
St. Paul, Minn.

Star Novelty
674 University Ave.
St. Paul, Minn.

MISSOURI

Davidson's
321 Southwest Blvd.
Kansas City, Mo.

Original One Stop Record Service
3230 Roanoke Rd.
Kansas City, Mo.

Laclede Music Co.
4060 Laclede Ave.
St. Louis, Mo.

Original One Stop Record Serv
2721 Pine St.
St. Louis, Mo.

One Stop Record Serv.
2721 Pine St.
St. Louis, Mo.

•Uptown
617 N. Kings Hwy.
St. Louis, Mo.

Record Van
2025 E. Grand
P. O. Box 6391
St. Louis, Mo.

George Glass Rec's
1901 Delmar Ave.
St. Louis, Mo.

•One Stop Record Serv.
1901-1903 Dalman St.
St. Louis, Mo.

MISSISSIPPI

Modern Appl. & Music
Box 516
McComb, Miss.

MONTANA

Rocky Mountain
433 St. John's Ave.
Billings, Mont.

NEBRASKA

Al Dahle
Box 7—Sta. "A"
Omaha, Nebr.

Davidson One Stop
1214 Farnam
Omaha, Nebr.

Records
2500 Harney
Omaha, Nebr.

Dart Records
2500 Harney Ave.
Omaha, Nebr.

Lieberman's
809 S. 25 Street
Omaha, Nebr.

NEVADA

Ranchito
5680 W. Virginia
Reno, Nev.

NEW HAMPSHIRE

Manchester Music
89 Manchester St.
Manchester, N. H.

NEW JERSEY

Fairbanks & Co.
818 S. High St.
Burlington, N. J.

Melody Record Shop
1172 Elizabeth Ave.
Elizabeth, N. J.

Regent Music
14-16 Plaza Rd.
Fairlawn, N. J.

Relic Rack
136 Main St.
Hackensack, N. J.

Belmont
268 15th Ave.
Newark, N. J.

A. Giacobbe Records
261 So. Orange Ave.
Newark, N. J.

Ideal Record Prod.
357 Lyons Ave.
Newark, N. J.

Service One Stop
382 Clinton Place
Newark, N. J.

Branford Music
14 Brandford Place
Newark, N. J.

New Jersey OS
347 Washington St.
Newark, N. J.

Raymar Sales
357 Lyons Avenue
Newark, N. J.

Red Top
261 S. Orange Ave.
Newark, N. J.

Service One Stop
Route 22 & Fadem Rd.
Springfield, N. J.

Garden State Dist.
68 W. Passaic St.
Rochelle Park, N. J.

NEW MEXICO

Gulf Mart
5000 San Mateo N.E.
Albuquerque, N. M.

Melo-D-Lane
2421 Aztec N.E.
Albuquerque, N. M.

Western Wholesale
1701 Williams, S.E.
Albuquerque, N. M.

Gibson
701 E. Broadway
Hobbs, N. M.

Old Trail News Agcy
525 W. Alameda
Sante Fe, N. M.

NEW YORK STATE

Bee Gee Dist.
26 Rear No. 3rd St.
Albany, N. Y.

Harpers
97 N. Pearl St.
Albany, N. Y.

L&L Dist.
30 N. 3rd St.
Albany, N. Y.

Almor & Co.
10 Leonard St.
Amsterdam, N. Y.

All Records
35-05 Broadway
Astoria, N. Y.

National Record Service
496 Chenango
Binghamton, N. Y.

One Stop Record Service
109 Water
Binghamton, N. Y.

•Buffalo One Stop
959 Main St.
Buffalo, N. Y.

Florence One Stop
875 Main St.
Buffalo, N. Y.

Merit Vending Co.
1503 Broadway
Buffalo, N. Y.

Transcontinental
959 Main St.
Buffalo, N. Y.

(Continued on page 108)

SERVICE ONE-STOP DISTRIBUTORS

WE ARE THE NEW JERSEY ONE STOP

Complete Selection Of All Pops, LP's, C&W,
R&B, Oldies, Standards. (Title Strips)

Home Office

16 Fenwick St.

Newark, N.J.

201 243-8700

Branch Office

Rte. 22 & Fadem Rd.

(Runyon Bldg.)

Springfield, N.J.

DR 6-7666

Congratulations "Cash Box"
on your 23rd Anniversary
from

TONY GALGANO

"One-Stop-LP Record Service"

All types of records for premiums and giveaways

GALGANO DISTRIBUTING CO.

4135 W. ARMITAGE AVE., CHICAGO 39, ILL.

(All Phones: Dickens 2-7060)

ONLY MAJOR 1 STOP IN VIRGINIA !!!

PAT'S ONE STOP

- * COMPLETE LINE OF BUDGET LP'S
- * COMPLETE CATALOG OF STANDARDS

WE CARRY ALL LABELS—INDIES & MAJORS
LP'S REGULAR DIST. PRICE
NOTHING OVER STRAIGHT WHOLESALE

• FREE TITLE STRIPS

• SHIPMENT SAME DAY ORDER RECEIVED

PAT'S ONE STOP

216 East Main Street, Richmond 19, Va. (703) 648-4791

DEALERS and OPERATORS

For PROMPT, EFFICIENT Service
Try Our COMPLETE ONE-STOP Facilities
2 Locations to Serve You

AM BAT RECORDS, INC.

1111 Vine St., Cincinnati 10, Ohio
Phone 621-3252
Vern Hawk

and

1336 Xenia Ave., Dayton 10, Ohio
Phone 256-4212

Largest And Oldest Record One-Stop In The West

CALIFORNIA MUSIC CO.

2933 West Pico Blvd., L. A., Calif. 90006

Phone 733-1181

See Our California Music Export Ad On Page 110

ONE STOP MEANS SERVICE

That's how we made our reputation

- Most Complete and only one stop in Detroit handling all LP labels
- Complete stock of singles for dealers and operators
- Carry in inventory the standards

Having the most complete inventory enables you to get immediate service, one shipping charge, filling of special orders that means time saved by you. Contact:

CONSOLIDATED ONE STOP, INC.

13254 Linwood Avenue, Detroit 38, Michigan (313) TO 5-8665

Complete Selection of 45's, LP's and promotional records

LONG ISLAND'S LARGEST ONE-STOP GALAXY RECORD DISTRIBUTORS INC.



3236 Lawson Blvd.
Oceanside, L. I., N. Y.
Area Code 516, OR 8-6180

L. SCHONBERGER

"SCHONY'S" ONE-STOP

(Established 1943)

2602 TILDEN AVENUE BROOKLYN 26, NEW YORK

(PHONES: BUCKMINSTER 7-3576 AND 7-4581)

WE STOCK ALL LABELS. SPECIALIZING IN OLD RECORDS. ALL ORDERS SHIPPED SAME DAY.

MARTIN & SNYDER ONE-STOP

THE MOST COMPLETE ONE-STOP IN THE MIDWEST
Complete Line of Standards and Foreign Records

IF IT'S A RECORD... WE HAVE IT

13200 W. Warren Dearborn, Michigan
(313) LU 2-5850 Chet Kajeski, *President*

ONE STOPS

Double B
240 E. Merrick Road
Freeport, L. I., N. Y.

Wilmi Sales
3 W. Moreland
Hicksville, L. I., N. Y.

Variety Record Dist.
93 Arleigh Rd.
Kensington, N. Y.

•Steadman's One Stop
140 East Third St.
Mount Vernon, N. Y.

•Galaxy
3236 Lawson Blvd.
Oceanside, N. Y.

Bandstand Record
15½ N. Main St.
Pt. Chester, N. Y.

Ebony Music Supply
6405-D Louisiana Ave.
Plattsburgh, New York

Toy House Of H. V.
Manchester Rd.
Poughkeepsie, N. Y.

Rochester One Stop
215 Monroe Ave.
Rochester, N. Y.

Star One Stop
17 Clinton Ave. N.
Rochester, N. Y.

One Stop Record Sales
517 Erie Blvd. E.
Syracuse, N. Y.

Syracuse One Stop
515 Erie Blvd.
Syracuse, N. Y.

Mal Hurwitz
6 Dellwood Rd.
White Plains, N. Y.

NEW YORK CITY

Schony's One Stop
2602 Tilden Ave.
Brooklyn, N. Y.

L. Schoenberger
2602 Tilden Ave.
Brooklyn, N. Y.

Town Hall
9131 Bedell Lane
Brooklyn, N. Y.

Fulton Radio Service
490 Clarmont Parkway
Bronx, N. Y.

Stratford Dist.
178-22 Jamaica Ave.
Jamaica, N. Y.

•Raymar
170-21 Jamaica Ave.
Jamaica, N. Y.

New Deal
45-18 Court Sq.
Long Island City, N. Y.

A-1 Records
659 10th Ave.
New York, N. Y.

Arovax Records
620 W. 51st St.
New York, N. Y.

Conlas
324 W. 49th St.
New York, N. Y.

Eastern Record
751 10th Ave.
New York, N. Y.

Hector
333 Sixth Ave.
New York, N. Y.

Independent Record Promo
258 W. 18th St.
New York, N. Y.

King Karol
111 W. 42nd St.
New York, N. Y.

New York Record Dist.
15 W. 20th St.
New York, N. Y.

One Stop Service
5 E. Third St.
New York, N. Y.

Second Ave. Record Shack
2132 2nd Ave.
New York, N. Y.

Win Records
858 9th Ave.
New York, N. Y.

NORTH CAROLINA

Bid Dist.
124 W. Morehead St.
Charlotte, N. C.

Southeastern
126 M. Morehead St.
Charlotte, N. C.

OHIO

M&G Record Serv.
47 E. Mill St.
Akron, Ohio

Ambat
1111 Vine St.
Cincinnati, Ohio

Royal Dist. Inc.
1210 Glendale-Milford Rd.
Cincinnati, Ohio

Whirling Disc
1036 Gilbert Ave.
Cincinnati, Ohio

Mobile Rec Service
2701 St. Clare Ave.
Cleveland, Ohio

•Northern Record Sales
2006 Prospect
Cleveland, Ohio

Ambat
1336 Xenia Ave.
Dayton, Ohio

Century Record Sales
849 N. High St.
Columbus, Ohio

Keller's Melody Sales
904 W. Delaware
Toledo, Ohio

Plaza
309 Boardman Plaza
Youngstown, Ohio

Record Rendezvous
301 W. Federal St.
Youngstown, Ohio

OKLAHOMA

Advance One Stop
129 N.W. 23rd St.
Oklahoma City, Okla.

All Records
520-522 Classen Blvd.
Oklahoma City, Okla.

Phil's OS Records
705 N.W. 4th St.
Oklahoma City, Okla.

Broadcast Record Dist.
2223 S. Florence Place
Tulsa, Okla.

Majestic One Stop
406 S. Main St.
Tulsa, Okla.

Tops One Stop
105 W. 6th St.
Tulsa, Okla.

(Continued on page 109)

*The friendliest one-stop
on the west coast*

LUENHAGEN RECORDS INCORPORATED

2277 W. Pico Blvd.

Los Angeles, Calif.

DU 4-4134

ONE STOPS

TTT One Stop
213 E. 6th St.
Tulsa, Okla.

OREGON

Thompson
62 W. Broadway
Eugene, Ore.

Portland One Stop
511 S.W. 6th Ave.
Portland, Ore.

Sea-Port Record One Stop
21 N.E. 7th Ave.
Portland, Ore.

Sixth Ave. Records
511 S.W. Sixth
Portland, Ore.

PENNSYLVANIA

D&H Dist.
2525 N. 7th St.
Harrisburg, Pa.

Wambachs
67 Colonial Park Plaza
Harrisburg, Pa.

American Record Sales
4821 Cedar Ave.
Philadelphia, Pa.

• **I. J. Morgan**
511 N. Broad
Philadelphia, Pa.

JB Record Service
1242 W. Girard Ave.
Philadelphia, Pa.

• **Slatkin's**
4095 Lancaster
Philadelphia, Pa.

A. Williams
1605 N. Broad
Philadelphia, Pa.

• **J&S Williams**
1606 N. Broad
Philadelphia, Pa.

• **All Brands**
1903 Fifth Ave.
Pittsburgh, Pa.

East Coast
633 Liberty Ave.
Pittsburgh, Pa.

Klein's Logan Variety
1811 Center Ave.
Pittsburgh, Pa.

United
Dept. 1-A
411 Gordon St.
Reading, Pa.

Dee Jay
528 Main St.
Stroudsburg, Pa.

Barnes Record Dist.
13 W. White St.
Summit Hills, Pa.

RHODE ISLAND

Beacon Shops
821 N. Main St.
Providence, R.I.

SOUTH CAROLINA

Savitz
115 Public Sq.
Abbeville, S.C.

South Carolina OS
107 E. Washington St.
Abbeville, S.C.

Fox
537 King St.
Charleston, S.C.

TENNESSEE

Jack's
14 E. 9th St.
Chattanooga, Tenn.

Knox Record Rack
2000 Western Ave.
Knoxville, Tenn.

Bluff City Record
3442 Jackson
Memphis, Tenn.

Home of the Blues
107 Beale St.
Memphis, Tenn.

Poplar Tunes
306 Poplar
Memphis, Tenn.

Buckley's
1707 Church St.
Nashville, Tenn.

Ernie's
179 3rd Ave. N.
Nashville, Tenn.

Hermitage Music
469 Chestnut St.
Nashville, Tenn.

Sanders Dist.
612 8th Ave.
Nashville, Tenn.

TEXAS

Tolzien Music
819 Polk St.
Amarillo, Texas

W-M One Stop
1601 W. Third
Amarillo, Texas

D. J.
2315 Briarwood Lane
Carrollton, Texas

South Texas One Stop
470 Palerma
Carpus Christi, Texas

Big State Dist.
1337 Chemical Row
Dallas, Texas

L & F One Stop Record
1327 Chemical Row
Dallas, Texas

Music Box
1327 Crampton
Dallas, Texas

B & C Record Sales
427 W. San Antonio St.
El Paso, Texas

Julius Berg
412 San Francisco
El Paso, Texas

Conwell Dist. Co.
1830 Mills St.
El Paso, Texas

M. B. Krupp Dist.
311 S. Santa Fe
El Paso, Texas

Sunland
2227 Texas Ave.
El Paso, Texas

Westex Record Serv.
P. O. Box 15282
Ft. Worth, Texas

Acme Record Dist.
91 Dennis St.
Houston, Texas

Central Sales
91 Dennis
Houston, Texas

H. W. Daily, Inc.
314 E. 11th St.
Houston, Texas

Record Service
610 Dennis St.
Houston, Texas

United Record Dist.
1613 St. Emanuel St.
Houston, Texas

Rosen Wholesale
621 Broadway
Lubbock, Texas

H. W. Daily Inc.
304 S. Main
San Antonio, Texas

E & R Record Shop
911 E. Houston
San Antonio, Texas

Santone Sales
121 Navarro
San Antonio, Texas

UTAH

Utah Sundries
1550 S. Redwood Rd.
Salt Lake City, Utah

VIRGINIA

Giant Music
110 W. Broad St.
Falls Church, Va.

(Continued on page 110)

SEVENTEEN YEARS

of Satisfying Service to thousands of customers thru the 50 States
with our FAST one-day mail-order service via our nightly shows on:

KWKH, Shreveport
(50,000 watts)

KEEL, Shreveport
(50,000 watts)

KAAY, Little Rock
(50,000 watts)

YOU GET THE ACTION YOU WANT FROM:

• • • STAN THE RECORD MAN • • •
(HITMAKER OF THE SOUTH)

ONE-STOP SERVICE TO STORES AND OPERATORS

★ Best Prices ★

• Export Service & Advice • Complete Stock of Singles • LP's—Little LP's • Gold
Standard Catalogue • Oldies But Goodies • Spirituals • R&B—Pop—C&W • Juke
Box Standards • Free Title Strips

So—No matter what your need may be—STAN THE RECORD MAN has it in stock
and can give you ONE DAY SERVICE (Orders Shipped Same Day Received).

Phone (318) 422-7182

STAN'S RECORD SERVICE

728 TEXAS STREET

SHREVEPORT, LOUISIANA

ONE-STOP Record Service

TRIED THE REST?
NOW TRY THE BEST!

- Same Day Service.
- Complete Inventory: We Guarantee Most Complete Fill of Your Orders.
- Best Prices: No One Beats Our Prices.
- LP Deals: Write for Details.
- Export Orders: processed immediately.
- Best Stock In Country On (Golden Oldies) 45's

SEND FOR
GIANT NEW "OLDIES" CATALOG

New York's Major One-Stop
Now Celebrating Our
19th Successful Year.

TOWN HALL RECORD ONE-STOP

9131 BEDELL LANE
BROOKLYN 36, N. Y.
BR 2-9702

IN THE UPPER MIDWEST

WHY

DO MORE ROUTE OPERATORS

BUY

ALL OF THEIR 45'S

FROM

THE TWIN CITIES'
NO. 1 ONE-STOP

BBI?

SERVICE-SELECTION-RELIABILITY

BROWN BROS., INC.

2321 WASHINGTON AVE. NORTH

MINNEAPOLIS, MINN. 55411

JA 2-6648—AREA CODE 612

DOUBLE

B

RECORDS CORP.

a singular sales service for all.

240 E. Merrick Rd., Freeport, N.Y. 11520

Bernard Boorstein
Donato Liberatore

Freeport 8-2222

ONE STOPS

•Pat's
216 E. Main St.
Richmond, Va.

WASHINGTON

Disc City
410 Elliot W.
Seattle, Wash.

Seattle Record One Stop
125 1st Ave., N.
Seattle, Wash.

Music Box
417 W. Riverside Ave.
Spokane, Wash.

WEST VIRGINIA

Elkins Music
160 Court St.
Charleston, W. Va.

Courts
Box 9
Culloden, W. Va.

Music Man
803 8th Ave.
Huntington, W. Va.

WISCONSIN

Music Mart
164 E. Washington St.
Burlington, Wisc.

Midwest Radio
3414 W. North Ave.
Milwaukee, Wisc.

Modern Rec. Dist.
2715 W. Lisbon St.
Milwaukee, Wisc.

Radio Doctors
213 W. Wells St.
Milwaukee, Wisc.

STERLING

TITLE STRIPS

FOR ALL RECORD LABELS

WORLD'S LARGEST STOCK OF
STANDARDS — ALL LABELS

HIT PROGRAM SERVICE

WEEKLY MAILINGS

Sterling Title Strip Co., Inc.

1175 Broad St. Newark, N.J. 07114
201 - BI 3-0222 212 - MU 2-7783

—FOR RECORDS—

California Music Export Co.
(A division of Calif. Music Co.)

LARGEST RECORD EXPORTER ON THE U. S. WEST COAST

—Since 1935—

FASTEST SERVICE

To overseas buyers in the Far East . . .
Pacific Countries, Hawaii, Alaska, Mexico, Central America and
South American Countries.

- COMPLETE INVENTORY on all labels, LP and 45 RPM
- SPECIAL RECORD ORDER PROGRAM (SROP) available to all Military Base Exchanges.
- ONE FREIGHT CHARGE.
- PROMPT SERVICE and FREE Title Strips to Juke Box Operators.

—Write for prices and information—

CALIF. MUSIC EXPORT CO.

2933 West Pico Blvd. Telephone 733-1181 Cable Address: CALMUSEX
Los Angeles, Calif. 90006, U.S.A.

**WE CARRY THE COMPLETE LINES
OF SINGLES AND LP'S**

To Offer Greater Service and Selection
to our Music Operator Friends

LORMAR SHIPS RECORDS ANYWHERE IN THE USA

Our New Location is at

LORMAR Record Dist. Co.

2311 N. Western Ave., Chicago 47, Ill.

Phones: BR. 8-8300

U.S. RECORD EXPORTERS

Amesay Trading Co., Inc.
55 Broadway, N.Y.

Bruno-New York, Inc.
460 W. 34th St.,
N.Y., N.Y.

Calif. Music Export Co.
2933 West Pico Blvd.
Los Angeles Calif.

Cardinal Export Corp.,
135 W. 29th St.,
N.Y., N.Y.

Daro Exports, Ltd.,
424 Madison Ave., N.Y.C.

Dixie Record Service
700 N. Conception
Mobile, Ala.

Eltron Export Co.,
122 Broad St., N.Y.C.

David Eskin-Int. Sales
400 Riverside Dr.,
N.Y. 25, N.Y.

Gateway Mercantile Co.
408 S. Alvarada St.
Los Angeles 57, Calif.

Harbor Record Export
8701 Shore Rd.,
B'klyn 9, N.Y.

Kaco Ent.
2444 Throop Ave.
Bronx, New York

Pan World Import Export Co. Inc.
2020 W. Washington Blvd.
Los Angeles 18, Calif.

Paradiso
71 East Ave.
Norwalk, Conn.

Record & Tape Sales Corp.,
821 Broadway
655 Lexington Ave.
New York, New York

Alex S. Roberts Associates, Inc.
99 Beekman St.,
New York 38, N.Y.

Albert Schultz, Inc.
116 W. 14th St.,
N.Y. 11, N.Y.

RECORDS

For Export

All American Labels,
Extremely Attractive Prices
and
Speedy Service

**CARDINAL
EXPORT CORP.**

135 West 29th St.
New York, N.Y. 10001

50%

Discount

On All American And
Imported Gramophone
Records.

ALL PRERECORDED TAPES
FASTEST SERVICE
CATALOGUES FREE ON REQUEST

DAVID ESKIN

INTERNATIONAL SALES
400 Riverside Drive
New York 10025, USA

RECORDS • EXPORT

All Speeds • Low Prices
All American brands
combined into

ONE SHIPMENT!

ELTRON

Export Company

122 Broad Street New York 4, N. Y.

Cable: ELTRONCOMP

**SERVING MUSIC
OPERATORS AND
RECORD DEALERS
THROUGHOUT THE
U.S.A.**

**MAIL ORDERS SHIPPED
SAME DAY AS RECEIVED**

**MOST COMPLETE STOCK
OF SINGLES AND LP'S**

**TWO
LARGE LOCATIONS**

WESTERN ONE STOPS, INC.

OAKLAND

1461 Park Ave., Emeryville 94608
415-654-5110

SAN FRANCISCO 94103

224 6th St., HEmlock 1-3367

CADET DISTRIBUTING CO., INC.

STOP ONCE FOR ALL

BEST SERVICE — ALL LABELS
COMPLETE CATALOG

13380 CAPITAL AVE.

548-3171

OAK PARK, MICH. (DETROIT) 48237

RECORD PROMOTION & PUBLICITY OFFICES

ATLANTA

Burkap Assoc.
Morley Siskin
330 Peachtree Bldg. N.E.
522-3153/524-2189

Music Pit
Jack Lynn
4 Broad St. S.W.
70 Pryor St. S.W.
523-2678

BEAUFORT, S.C.

Phonosonic Entertainment
Bobby Lee
1602 Greenlawn Pk.
524-5177

BOSTON

Ed Hurvitz
Music Promotions
89 Hollingsworth St., Mattapan
298-0574

Ed Penny
St. George Hotel
Kenmore Sq.
CO-6-0060

New England Record Promo
Ed Dwellingham
106 Northampton St.
HI-2-3830

New England Record Promo
Steve Sandler
495 Huntington Ave.
Hyde Park
361-2567

BUFFALO

Carl Cisco
1106 Elmwood Ave.
Cherry, N.J.
Gardner Co.
116 E. Cherry Hill Apts.

CHICAGO

Erwin Barg
5335 N. California Ave.
UP 8-9164

Eva Dolin
3950 Lake Shore Dr.
BU 1-6937

Earl Glickin
1770 Winthrop Rd.
Highland Park
ID-3-1771

Cooper C. Golin
360 N. Michigan
ST 2-4372

Paul Gallis
161 E. Erie
MO 4-6670

Bonnie Kroll
10 W. Elm
SU 7-1549

Peter H. Wright Associates
185 N. Wabash
236-6185

Record Promo
Waco Austin
2443 W. 34th Pl.
847-6779

Recordland Record Corp.
Ed Kaplan
13673 Wales-Oak Park
LI 2-2338

Tri-State Productions
Paul Wilczynski
3645 N. Pueblo Ave.
625-6848

Peter H. Wright Assoc.
185 No. Wabash Ave.
236-6185

CINCINNATI

Julie Godsey
265 Jupiter Dr.
921-8722

CLEVELAND

Betty K. Gardner
2329 Lyndway Rd
Beechwood Village

Perry Stevens
2208 Edgerton Rd.
University Hts.
321-0641

Marv Helfer
2130 Marshfield Rd.
449-5635

COLUMBUS, OHIO

Dave Segel
1049 Oakwood Ave.
252-5839

DETROIT

Al Abrams
2648 W. Grand Blvd.
TR 1-3340

Sheldon Brown
3942 3rd Ave.
TE 3-5383

IBA Enterprises
Ian Gaum
19961 Prest
831-7326/342-8022

FAIR LAWN, N. J.

Mike Siegel
796-4192

FARMINGTON, CONN.

Dave Fox
22127 Malden

JERSEY CITY

James Buckowski
158 Woodlawn Ave.
HE 3-7693

KEY WEST

Steve Keegan
P. O. Box 810

LAS VEGAS

Mary DuBose Reetig
5035 S. Tamarus
RE 3-1570

LOS ANGELES

Barbara Best
6223 Selma
HO 6-4246

Jay Berbsteln
435 N. Bedford
Beverly Hills

Chuck Blore
10439 Valley Spring Lane
N. Hollywood
761-9844

Brandy & Pam
226 So. Beverly Dr.
CR 4-6928

Braverman-Mirisch
9255 Sunset Blvd.
CR 5-5169/BR 2-8608

Carter/Carr
9155 Sunset Blvd.
CR 3-8500

Colbert & Edwards
6257 Leland Way

Contemporary Public Relations
P.O. Box 1406
CR 1-9179

Corcoran-Tanner & Co.
161 W. 54 St.
765-0528

Enyart & Rose
5735 Melrose Ave.
HO 6-1176

Ernie Farrell
999 N. Doheny Dr.
CR-1-7858

Fields Unlimited
Barney Fields
5750 Melrose Ave.
HO 7-0450

Maury Foladare Assoc.
1717 No. Highland

Freeman-Sutton Assoc.
6606 Sunset Blvd.

Tim Gayle
6376 Yucca St.
HO 3-2151

Dave Gershenson
Capitol Tower

Great Western Assoc.
Pat Shields
1737 Northwestern Ave.
HO 6-0874

Hanson & Schwam
6705 Sunset Blvd.
HO 6-9222

Hoenig-Edwards
7185 W. Sunset

Honeycomb Productions
6606 Selma Ave.

Jerry Hoffman & Paladino
9165 Sunset Blvd.

Arthur Jacobs
9229 Sunset Blvd.

(Continued on next page)

NATIONAL RECORD PROMOTION

Complete Disc Jockey coverage
Radio & T.V. Interviews, Records hops.

TRADE PAPER PUBLICITY

News, Items, reviews, corporate image.

CONSULTATION

All questions answered . . . Distribution, Pricing, Recordings, Union Rules, Music Publishing

PRESSING

No Job too small.

DISTRIBUTION ARRANGED



MORTY WAX
PROMOTIONS
A DIVISION OF THE HOUSE OF WAX

1650 B'way • N.Y. 19, N.Y. • CI 7-2159

CHARLOTTE ROGERS

Publicity
Exploitation - Public Relations

+++

HOLLYWOOD ROOSEVELT
HOTEL

700 Hollywood Blvd.,
Hollywood, Calif. 90028
HO. 6-3443 HO. 9-2442

THE MERRICK COMPANY

Public Relations

New York: 18 East 48th Street, New York, N.Y. 10017

PL 2-4111

Los Angeles: 9000 Sunset Blvd., Los Angeles, Calif. 90069

CR 8-1211

JERRY SIMON

RSVP

RECORD SALES VIA PROMOTION

SALES CONDITIONED PROMOTION

WITH DIRECT EMPHASIS ON

DISTRIBUTORS—RADIO STATIONS—ONE STOPS

1650 Broadway, New York 19, N.Y., JUdson 6-6707



RECORD PROMOTION & PUBLICITY OFFICES

George Jay
6290 Sunset Blvd.
HO 9-5838

Jerry Johnson
5645 Radford Ave.
FO 2-6951
N. Hollywood

Bob Jones
Box 38530
Bernard F. Kamins
190 N. Canon Dr.
CR 1-8141

Kragen-Carroll
451 N. Canon Dr.
Beverly Hills
273-5011

Sam Laine
9012 Sunset Blvd.

Frank Liberman
8733 Sunset Blvd.

Mann Scharf & Co.
9056 Santa Monica Blvd.
CR 4-6222

Bernice Mason
6223 Selma Ave.
HO 7-3084

McFadden, Strauss, Eddy,
Irwin & Goodman
1017 N. La Cienega Blvd.
OL 7-4330

Stan Pat Promo
6269 Selma Ave.
HO 6-4439

Prestige Promotions
Derek Taylor
6290 Sunset Blvd.
NO. 9-3641

Charlotte Rogers
7000 Hollywood Blvd.

Rogers & Cowan
250 No. Canon Dr.

Glenn Rose
8440 Sunset Blvd.
654-3800

George Russell
1308 N. Martel
PO 6-7161

Lenny Salamone Promo
24320 Calvert St.
TR 7-5441

Robert Sande
7141 No. Ivar Ave.

Gene Shefrin Assoc.
141 El Camino
CR 3-6226

Sloan Co.
8979 Sunset Blvd.

Studio City Advertising
Sandy Beck
2559 W. Pico Blvd.
388-3251

Talco Ent.
6201 Santa Monica Blvd.

Tres Promotions
6223 Selma Ave.

View Music Co.
Marvin Liblick
965 So. Magnolia Ave.
383-0226

Winter & Kafafian
1551 N. La Brea

Irwin Zucker
6515 Sunset Blvd.

LOUISVILLE, KY.

Orbit Radio
P.O. Box 1644

LURAY, VA.

Earl Rothgeb Promo
P.O. Box 208
RI 3-5394

MIAMI

National Entertainment
2805 Biscayne Blvd.
374-1231

Professional Programming
Robert R. Harris
9701 Southwest 77th Terrace
271-0839

NEW YORK

Floyd F. Ackerman Assoc.
145 West 55th St.
CO 5-4122

Adrian Associates
130 West 42nd St.
OX 5-7965

Advance Public Relations, Inc.
234 West 44th St.
LO 3-4370

Allstan Enterprises, Inc.
255 W. 55 St.
JU 6-2948

Sidney Ascher Assoc.
1545 Broadway
LT 1-2287

David O. Alber
44 East 53rd St.

N. W. Ayer & Son
Florence McDermott
1271 Ave. of The Americas
PL 7-5700

Buddy Basch
17 East 45th St.
MU 7-8351

Joyce Becker
c/o Pioneer
1650 Broadway
LT 1-0030

Doc Berger
931 E. 28th St.
DE 8-5965

Ivan Black
400 Madison Ave.
PL 5-4760

Raysa Bonow
523 E. 78th St.
TN-7-2260

Tim Boxer
1650 Broadway
CI 7-6646

Mal Braveman
15 East 48th St.
EL 5-7752

Breakout Promotions
Bob Yorey
1650 Broadway
CI 5-2772

Chuck Brown
400 Madison Ave.
HA 1-4580

Paul Brown
507 5th Ave.
MU 7-3071

Budd Prod.
Budd Hellawell
157 W. 57th St.
CI 7-4896

Connie DeNave
200 West 57th St.
JU 6-1330

Bill Doll
1700 Broadway
JU 6-8894

Henry O. Dorman
55 East End Ave.
EL 5-0400

Marvin Drager
424 Madison Ave.
MU 8-1078

Austin Drew, Inc.
Phillip Austin
P.O. Box 131—White Plains
WH. 9-5263

Charlie Earle
1776 Broadway
JU 6-6994

Jack Egan
45 Wendover Rd.
Yonkers
YO 8-7969

Ehrlich & Gluck
200 W. 57th St.
LT 1-6342

Alan Eichler Assoc.
864 Broadway
AL 4-7604

Harold Ettus
Hotel Empire
Broadway & 63rd St.
CO 5-7400

Alan Foshko
350 W. 52nd St.
JU 2-2417

The Lynn Farnol Group
50 Rockefeller Plaza
JU 6-5777

Mildred Fields
67-11 Parsons Blvd.

Fourbees Enterprises, Inc.
Buddy Friedlander
850 7th Ave.
JU 6-8790

Chester Fox
18 W. 70th St.
SU 7-1597

Kim Garfield Assoc.
527 Madison Ave.
HA 1-0225

Richard Gersh Assoc.
Dick Gersh
200 W. 57th St.
CI 7-4161

Glenn Productions
Ben Arrigo
157 W. 57th St.
CO 5-6585

Gordon-Mansfield Ent.
250 West 57th St.

Ren Grevatt
200 W. 57th St.
247-4163

Gurtman-Vandervort & Bob Cochran
161 W. 54th
CI 5-4771

Jim Harrison
110 W. 47th St.
JU 6-6300

Dave Hepburn Ent.
1697 Broadway
CI 6-2398

Ell Lloyd Hoffman
16 Court St.
875-6825

Constance Hope Assoc.
225 W. 57th, N.Y.C.

Bernie Ilson
400 Madison Ave.
HA 1-4580

Arthur P. Jacobs Co.
17 East 54th St.
TE 8-0730

Eddie Jaffe
156 W. 48 St.

JLJ Enterprises
40 Central Pk. So.

Milton Karle
440 East 56th St.
MU 8-8788

The Kalmus Corp.
445 Park Ave.

Monte Kay
200 W. 57th St.

Kragen-Carroll
39 W. 55th St.
CO 5-5938

Philip Leshin Assoc.
565 5th Ave.
TN 7-5080

John Levy Ent.
119 West 57th St.
CI 5-2488

Jim Mahoney
510 Madison Ave.
PL 1-2060

(Continued on next page)

TIM GAYLE and Associates

WEST COAST and NATIONAL

... Top level PUBLICITY
... Solid Push PROMOTION
... Effective Public Relations

Years of Experience/Know-How/
Contacts/Ability/Results

From lead sheet to studio, to
pressings and distribution . . .
we've had the experience!

6372 Yucca Street
Hollywood, Cal. 90028
Area code 213, Tel. HO 3-2151

PROMOTION IN MOTION

So. Calif. — West Coast — National



IRWIN ZUCKER & Associates

K. Terry • Steve Adler • Cathy Britton

6515 Sunset Blvd.
Hollywood, Calif. 90028
(213) HO 6-9594

LOOKING FOR BREAKOUT ACTION In The DETROIT Market?

CONTACT

SAMMY KAPLAN, INC.

RECORD PROMOTION & PUBLICITY

NORTHLAND TOWERS—SUITE 106—SOUTHFIELD, MICHIGAN

TEL: (313) 442-5938

Proudly representing distinguished artists
and companies in the music industry

CARTER/CARR

Public Relations
9155 Sunset Boulevard, Los Angeles, California
Telephone: CR-3-8500

For the most effective promotion
on the West Coast
LENNY SALAMONE
24320 Calvert St., Woodland Hills, Calif.
213-TR-7-5441

RECORD PROMO & PUBLICITY OFFICES

Whit Marshall
Hotel Somerset
150 W. 47th St.
PL 7-2780

Merrick-Shefrin
18 E. 48th St.
PL 2-4111

Jim McCarthy
1619 Broadway

McFadden, Strauss, Eddy & Irwin
509 Madison Ave.
421-7610

Dick Miller
1545 Broadway
LT 1-9161

Joe Morgan
50 Central Park W.

Walter J. Murphy
336 E. 86th St.
TR 9-6148

Music Makers
Joey Sasso

Shelton Towers,
49th & Lexington
PL 3-4951

Bert Nevins, Inc.
527 Madison Ave.

Henry Okun
157 W. 47th St.

Larry Penzell
501 Madison Ave.
PL 9-3890-1-2

Bob Perilla
745 5th Ave.

Fred Perri
1472 Broadway
BR-99642

Joe Petralia
Park Sheraton Hotel
JU-66935

Arthur Pine Assoc.
1780 Broadway
CO 5-7330

Gerald Purcell
210 E. 53rd St.
PL 3-7602

Queen Artist Corp.
1697 Broadway
CI 6-2398

Public Relations Corp. of America
Saul Richmond
151 E. 50th St.
PL 2-0040

Reggie Riccardi
135 W. 55th St.
CI 7-1233

Saul Richfield
1697 Broadway
CI 7-5907-8

Richard H. Roffman Assoc.
675 West End Ave.
RI 9-3647

Rogers & Cowan
598 Madison
PL 9-6272

Dorothy Ross
300 W. 55 St.
247-5560

Seven Investors Co.
Tom Della Corte
P.O. Box 348—Yonkers
BE 7-0381

Eve Siegel Assoc.
35 West 53rd St.
MU 8-4598

Don Simmons & Assoc.
1841 Broadway
JU 2-6311

Jerry Simon
RSVP
1650 Broadway
JU 6-6707

Solters, O'Rourke & Sabinson
62 W. 45th St.
TN 7-8500

Bill Spitaisky
40 West 57th St.
246-4280

John Springer Assoc.
667 Madison Ave.
421-6720

SRO Artists
240 Central Park South

Gary Stevens
Al Thal
42 E. 52nd St.
PL 3-1755

Mario Trombone
40 E. 49th St.
PL 2-8660

William F. Treadwell, inc.
Time & Life Bldg.
PL 7-7656

Universal Public Relations
342 Madison Ave.

Harriet Wasser
2850 Clafin Ave.
Bronx, N.Y.

Morty Wax
1650 Broadway
CI 7-2159

Gene Weber Assoc.
730 5 Ave.
JU 2-3925-6

Jay Weston
50 Central Park West
TR 4-2060

Al Wilde
240 Central Park So.
CI-5-7450

Irving Zussman
400 Madison Ave.
EL 5-5773

PALISADES, N.J.

Sol Abrams
Palisades Amusement Park
WH 5-1000

PELHAM, N.Y.

Public Relations Int'l.
Bill Smith
P.O. Box 155
738-9862

PHILADELPHIA

George E. Costello
232 Jamestown St.

Ed Coliar
723 Spruce St.
MA 7-7826

Buzz Curtis
2201 Brynmawr
GR 3-4030

Ross Associates
250 So. Broad St.
PE 5-1050

R/P Radio Promotions
2200 Pine St.
HO 2-7993

PITTSBURGH

Jane Oliver
9 Club Drive, East
884-4172

SAN FRANCISCO

Kathy Furness & Assoc.
703 Market St.
PR 5-3905—DO 2-0106

SAN RAFAEL, CAL.

Ted Ponseti
221 Knight Dr.
453-4388

SILVER SPRINGS, MD.

Tri-Fi Productions
Cal Hackett
9419 Georgia Ave.
587-3965

SUMTER, S. CAR.

Trend Records
Merrill Warner
P.O. Box 1647
773-7081

VIRGINIA BEACH, VA.

Creative Services
Robert Gheza
2022 Atlantic Ave.
428-0548

POLY BAG MANUFACTURERS

••Western Record Pressers Assn.

••Allied Record Dist. Co.
1041 N. Las Palmas
Hollywood, Calif.

Celanese Plastic Co.
744 Broad St.
Newark 2, N. J.

Chicago Trans. Bag Co.
4806 W. Chicago Ave.
Chicago, Ill.

Clear Print Co.
3639 Dyre Ave.
New York, N. Y.

Cari Cordover & Co.
104 Liberty Ave.
Mineola, N. Y.

D. & A. Transparent Bag Co.
550 Fifth Ave.
New York, N. Y.

Diamond Cellophane
2724 S. Michigan
Chicago, Ill.

Mehi Mfg. Co.
2057 Reading Rd.
Cincinnati 2, Ohio

••Research Craft Corp.
1011 N. Fuller Ave.
Los Angeles 46, Calif.

Whitaker Paper Co.
Eggleston Ave., 6th & Lock
Cincinnati, Ohio

- RECORD ENVELOPES, all sizes
- CORRUGATED BOARDS AND RECORD MAILERS
- STOCK LEGAL CONTRACTS for Music Publishers and Record Companies
- PRESSURE-SENSITIVE LABELS (for Recording Studios)
- FAN CLUB PHOTO CARDS

Sleeves—Stationery—Album Jackets
Invoices—Business Cards
Offset and Letterpress Printing
Custom Designed for the Music Industry
Price Lists Available Upon Request
ONE STOP SERVICE, INC.
133 E. 84th St. New York, N.Y. 10028
BU 8-4338 — Adam Gary

WEST COAST AND NATIONAL PROMOTION

representing

Tony Bennett—Columbia Della Reese—ABC Par.
Burl Ives—Decca Lou Rawls—Capitol
M 3's—United Artists

FIELDS UNLIMITED



BARNEY FIELDS

5750 Melrose Ave.
Hollywood 38, Calif.
213 HO 7-0450



studio city advertising

2559 West Pico Blvd. Los Angeles 6, California
Phone 388-3251

- THE RECORD GUIDE (Weekly)
- THE SURVEY OF HITS (Weekly)
- KRLA (Pop)
- KGFJ (R & B)
- KWKW (Latin American)
- FRONT & CENTER (Monthly) (Label Directory)
- OLDIES BUT GOODIES (Annually)
- TIN PAN ALLEY—WEST (Annually)

PUBLICATIONS SERVING THE MUSIC INDUSTRY

Specializing in...

PUBLIC RELATIONS FOR THE RECORD INDUSTRY

BRAVERMAN-MIRISCH, INC.

David Mirisch

Jack Devaney

9255 Sunset Blvd.

Los Angeles 69, Calif.

Phone: BR 2-8608

For The Fastest Play In The West

Contact

ERNIE FARRELL

(who's always at his best)

999 N. Doheny Drive, Los Angeles, Calif., Cr-1-7858

for excellence

in publicity and public relations

barbara best and associates

suite 209
6223 selma avenue

hollywood, california 90028
hollywood 64246

RACK JOBBERS

ALABAMA

Music Center
416 N. 19th St.
Birmingham, Ala.

Victory Record Service
1028 N. 1st. Ave.
Birmingham, Ala.—Joe Vetrano

Dixie Record Service
700 North Conception St.
P.O. Box 1192
Mobile, Ala.
Floyd E. Hall—Ed Farver

Reliable Records
103 Springdale Court
Gadsden, Ala.—C. R. O'Neal

M&F Record Suppliers
1630 6th Ave. North
Birmingham, Ala.—Fred Filippone

Music City
567 Houston St.
Mobile, Ala.—Albert Pardo

ARIZONA

•Arizona Sundries Co.
2949 N. 30th Ave.
Phoenix, Ariz.—George Souvall

•Record Service, Inc.
7140 North 11th Place
Phoenix, Ariz.

ARKANSAS

•Siebert's News Agency
6301 Forbing Road
Box 4375 Asher Statlon
Little Rock, Ark.—Sieg Siebert

CALIFORNIA

•National Record Service
1081 North Harbor Blvd.
Anaheim, Calif.—Wally Hill

Western One-Stops, Inc.
1461 Park Ave.
Emeryville 8, Calif.

•Record Service Co.
3517 Harmony Drive
Bakersfield, Calif.—Sam Clark

M&M Records
23 Mary Court
Danville, Calif.—Gordon C. George

•Tip Top Music Co.
2043 East Sierra Madre
Fresno, Calif.—Dave Urban

Western News Supply
461 North Weber
Fresno, Calif.—Bob Tenscher

Mel-Q-Disc Record Co.
16228 South Ball St.
Gardena, Calif.—Charles Burk

•Pic-A-Tune, Inc.
1461 Park Ave.
Emeryville, Calif.
John Edgerton

•Bertel Distributing Co.
5414 West Washington Blvd.
Los Angeles, Calif.—Herb Slegel

Julian Brown Enterprise
9106 S. Western Ave.
Los Angeles, Calif.
Lorin Wilson—Lloyd Thompson

•Cal Raks, Inc.
1499 West Washington Blvd.
Los Angeles, Calif.—George Hartstone

California Record Rack
2933 W. Pico Blvd.
Los Angeles, Calif.

Dale Record Service, Inc.
2940 West Pico Blvd.
Los Angeles, Calif.—
Sam Ricklin

•Leader Sales
3416 West Pico Blvd.
Los Angeles, Calif.—Len Silver

M&M Record Distributors
7070 Waring Ave.
Hollywood, Calif.—Milt Levine

•Music City Records Racks Inc.
4444 Sunset Blvd.
Los Angeles 27, Calif.
Glen C. Becker—Stuart Burnat

•Record Rack Service, Inc.
5873 Rodeo Road
Los Angeles 29, Calif.—Ed Mason

•Record Service
911 East 59th St.
Los Angeles, Calif.—Larry Nunes

Barbary Coast Record Rack Service
2556 Grove St.
Oakland, Calif.

•Tip Top Music Co.
1224 North "B" St.
Sacramento, Calif.

•Nor Cal
1175 Howard St.
San Francisco, Calif.—Leon Hartstone

Record Supply Dist.
154 S. Van Ness Ave.
San Francisco, Calif.

•Record Wholesalers, Inc.
2000 Oakdale
San Francisco, Calif.—Don Ayres

•Tip Top Music Co. Inc.
900 Minnesota St.
San Francisco, Calif.—Monroe Goodman

COLORADO

Gorman Dist. Co.
1303 Harlan St.
Denver (Lakewood), Colo.
Jim Gorman

Le Mac Distribution Corp.
2180 South Jason St.
Denver 23, Colo.—Lee Cantrell

•Mershaw Midwest
1950 Arapahoe
Denver, Colo.—Paul Marcus

Morton Record Co.
945 East Evans
Pueblo, Colo.—Herb & Max Martin

•Music Merchandisers Of
Denver
3825 Newport
Denver 7, Colo.—
Bill Turner
Pan American Record Supply
77 Kalamath St.
Denver, Colo.
•Western Merchants Wholesale
6265 E. Evans St.
Denver, Colo.—Robert Baker

CONNECTICUT

Music City Co.
959 State St.
Bridgeport, Conn.—Bill Bileca

Beacon Records
76½ Tolland St.
East Hartford, Conn.

•Park Record Dist.
313 Park Ave.
East Hartford, Conn.—Ed Steln

Trinity Records
477 Park Ave.
East Hartford, Conn.—Ed Di Nallo

Thompson Records, Inc.
Box 101
Quinebaug, Conn.

DELAWARE

Delaware News Agency
9th & Locust St.
Wilmington, Delaware—Stanley Borner

DISTRICT OF COLUMBIA

•District Records, Inc.
2146 24th Place NE
Washington, D.C.—Jay Jacobs-
James Schwartz

Richray Dists., Inc.
2400 17th St., N.W.
Washington 9, D.C.
D. Custer

Stacey Distributing Co.
1100 "F" Street N.W.
Washington, D.C.—Ed Fitch

FLORIDA

•Mershaw Co. Inc.
P.O. Box 3213
Jacksonville 6, Fla.

Budisco One Stop
280 N.W. 29th St.
Miami, Fla.

•L & F Record Service
3645 N.W. 7th St.
Miami, Fla.

•Mershaw of America
6771 N.W. 37th Court
Miami, Fla.—Murray Jacobs

Gold State Record Dist.
4504 N.W. 36th Ave.
Miami, Fla.—Marvin Lieber

Hicks News Agency
1316 N. Palm Ave.
Ocala, Fla.—Clarence Hicks

•Record Supply Co.
2634 Taft St.
Orlando, Fla.—R. Stultz

•Sunshine State Rec. Dists.
8170 N.W. 36th Ave.
Miami 47, Fla.
Charles Peters

Orange News Co.
122 Canal St.
Tallahassee, Fla.

D & M Post Cards & Records
5011 Georgia Ave.
West Palm Beach, Fla.—Don Ebbert

GEORGIA

All Purpose Service Co.
1456 Northside Drive N.W.
Atlanta 18, Ga.—Peter Parls

•Gate City Record Service
1209 Techwood Drive N.W.
Atlanta, Ga.—Jake &
Gerald Friedman

Sound Marketing, Inc.
1319 Spring St. NW
Atlanta, Ga.—Don Comstock

Budget Merchandising
207 Walker St. SW
Atlanta, Ga.

•L & F Record Service
1227 Spring St., N.W.
Atlanta, Ga.—Jack Geldbart

Clarksville Record Sales
P.O. Box 198, Washington St.
Clarksville, Ga.—Peter Roseffy

Southeast Record Sales
138 East 5th St.
Tifton, Ga.—Gus Statiras

HAWAII

Music-Hawaii, Inc.
474 Ena Road
Honolulu 15, Hawaii

Rack Service Hawaii
1354-A Kapiolano Blvd.
Honolulu, Hawaii—Bill Shipman

ILLINOIS

•Musical Isle Record
239 Ensenada Ave.
Carpentersville, Ill.—Robert Fleck

Brason Associates
512 S. Peoria
Chicago, Ill.—Dave Lande

Chicago Drug Co.
1335 W. Altgeld
Chicago 14, Ill.—Moe Handleman

Consolidated Record Sales
101 S. Cicero Ave.
Chicago 44, Ill.

•Hit Records
133 W. 111th St.
Chicago 14, Ill.—Charles Stevens

•Mid-America Specialty Dist.
752 N. Milwaukee Ave.
Chicago, Ill.—Howard Rosen

Randolph Enterprises
1130 E. Eldorado
Decatur, Ill.—Harvey Randolph

•Musical Isle Record Corp.
410 Elgin St.
Forest Park, Ill.—Bob Fleck

•R & R Record Dist.
7059 W. Addison St.
Chicago, Ill.—Robert Kennedy

Illinois News Service
507 N. Franklin
Peoria, Ill.

Paul Allen Rack Sales
111 Sun Valley Ct.
Peoria, Ill.

The Record Bar
109 N. Glendale Ave.
Peoria, Ill.

INDIANA

Midwest Dist.
933 Nuttman Ave.
Fort Wayne, Indiana

Tri-State Dist.
933 Nuttman Ave.
Fort Wayne, Ind.
Indiana Merchandise Co.

Associated Distributors, Inc.
210 South Meridian St.
Indianapolis, Ind.—L. E. Randle, Jr.

IOWA

Iowa News
115 7th St. S.E.
Cedar Rapids, Iowa—Stanley Seldler

(Continued on next page)

PROFIT VENDORS, INC.

Records & Accessories
3216 W. Lawrence Ave.
Chicago 25, Illinois
(Phone: IR 8-1441)

Presently Supplying...

Record Shops
Department Stores
Variety Shops
Appliance Stores
Furniture Stores
Drug Stores
Discount Centers
Advertising Agencies
Schools & Studios
All Little Al Record Shops

One Delivery, One Invoice,
Guaranteed Sale—
Guarantees Profit

RACK JOBBERS

Mid-State Dist.
1501 First Ave. S.E.
Cedar Rapids, Iowa—Bob Pockrandt

Mars Sales Corp.
1630 Locust St.
Des Moines, Iowa—Jack Mishler

•Quality Record Service Co.
1234 Harding Road
Des Moines 14, Iowa
Ralph Anderson

•Record Service Co.
326 Sycamore
Waterloo, Iowa—Don Belzer

KANSAS

•Rak Sales
609 Quincy St.
Topeka, Kansas

•Pioneer Dist. Co.
2955 S. Kansas
P.O. Box 2059
Wichita, Kansas
Alvin M. Driscoll

KENTUCKY

A. J. Eyl Co.
Industry Road
Lexington, Ky.

Handleman Co.
1023 S. 21st St.
Louisville, Ky.

Joy Record Co.
P.O. Box 126
Midway, Ky. 40347—Bill Buster

Pepton's Inc.
716 W. Main St.
Louisville 2, Ky.

LOUISIANA

Top Rak Record Service
524 Lafayette St.
Gretna, La.

Record Rack Sales
P.O. Box 10386
Jefferson Parrish, La.

•Modern Record Service
P.O. Box 3727
Lafayette, La.

Hel-lo Record Co., Inc.
912 Trudeau Dr.
Metairie, La.

Record Rack Service
108 Frisco Ave.
Metairie, La.

•Modern Record Service
755 Central Ave.
New Orleans, La.—Geo. Berry

MAINE

The Boyd Corp.
84 W. Cove St.
Portland, Maine—Bill Hill

Caron Co.
73 India St.
Portland, Maine—Jules Abramsor

Diamond Corp.
212 Anderson St.
Portland, Maine

MARYLAND

B & D Music
2342 E. Monument St.
Baltimore, Md.—Bill Gerhardt

Jalen Amusement Co., Inc.
1215 South Howard St.
Baltimore 18, Md.—J. Jones

Ellis Distributing Co.
5216 Fairlawn Ave.
Baltimore, Md.—Edgar Ellis

Stacey Distributing Co.
2275 Reiserstown Road
Baltimore, Md.—Ed Fitch

Interstate Record Distributors
116 North Potomac St.
Hagerstown, Md.—
Melvin & Richard Greenwald

Coronet Music
4724 Bonnie Brae Rd.
Pikesville, Md. 21208—Sam Anoff

MASSACHUSETTS

Boston Record Dist.
450 Harrison Ave.
Boston 18, Mass.

Disco Inc.
141 Milk St.
Boston, Mass.—Fred Traub

Boyd Corp.
33 Moulton St.
Cambridge 38, Mass.—James Boyd II

Temple Sales
4 Gordon St.
Jamaica Plain, Mass.—Myer Tannenbaum

•Somerset Corp.
203 Plymouth Ave.
Fall River, Mass.
Louis Freedman

U. S. Records
185 Riverside Ave.
Somerset, Mass.—Dan Gittleman

Lesley Sales Corp.
330 Reservoir St.
Needham Heights, Mass.
Abraham Levine—Arthur Govastès

•Recordwagon Inc.
30 Nashua St.
Woburn, Mass.—Cecil H. Steen

Alan Sales Co.
45 Stoughton Ave.
Webster, Mass. 01570—John Stolarczyk

Thompson Record Dist. Co.
Perryville Road
Webster, Mass.—H. Hammond

MICHIGAN

Cornell Records
13380 Capital Ave.
Oak Park, (Detroit), Mich.

Handleman Co.
670 E. Woodbridge
Detroit 26, Mich.
David Handleman—David Strome

Ludington News
1600 E. Grand Boulevard
Detroit, Mich.—Joe Sandifer

Monroe Dist. Co.
100 Hall St. S.W.
Grand Rapids, Mich.—Herman Rubin

Keego Dist.
12866 Woodward Ave.
Highland Park, Mich.

•Canfield Supply
210 Mill St.
Lansing, Mich.—Robert R. Canfield

Handleman Co.
1307 Turner St.
Lansing, Mich.

McGregor News
212 W. Michigan
Mount Pleasant, Mich.

Publisher News
U. S. at Grand Beach
New Buffalo, Mich.

Cornell Records
13380 Capital Ave.
Oak Park (Detroit), Mich.—Harry Levin

MINNESOTA

Dasco, Inc.
410 12th Ave. N.
Minneapolis, Minn.—Ken McGowan

Dart Records
730 Lyndale Ave. N.
Minneapolis, Minn.—Jack Taylor

•J. L. Marsh Co.
7600 Wayzata Blvd.
Minneapolis, Minn.
Dan & Amos Heilicher

•Rapid Merchandising Co.
8175 Lewis Road
Minneapolis, Minn.
Herbert Sandel—Noel Korengold

•Record Service Co.
1913 Plymouth Ave. N.
Minneapolis 11, Minn.—Donald Belzer

Twin City Novelty Co.
321 Plymouth Ave. North
Minneapolis, Minn.
David Lieberman—Richard Moerbitz

MISSISSIPPI

Record Rak, Inc.
110 Rear Cedars of Lebanon Road
Jackson, Miss.—John Reeves

MISSOURI

Top Notch Record
1415 Bobolink Place
Brentwood 17, Mo.

•K. C. Rak Sales, Inc.
701 W. 34th St.
Kansas City, Mo.

Reco Dist. Co.
4931 S. Benton
Kansas City, Mo.

Bootheel Music
201 First St.
Kennett, Mo.—
Dick Hillburs, John McMullan

Decatur Rak Sales
2721 Pine St.
St. Louis, Mo.
John Pohl

Missouri Disc
1906 Washington Ave.
St. Louis, Mo.

•Rak Sales Inc.
2549 Sullivan Ave.
St. Louis 7, Mo.
Sanford Goldman, Ed Ockel

MONTANA

Playhouse Inc.
1015 Poplar
Helena, Montana—Ben Hopkins

NEVADA

Music City Racks Of Nevada
5409 Gypsy Ave.
Las Vegas, Nevada—Alex Fox

Ranchito Dist. Co.
5680 S. Virginia Road
Reno, Nevada—D. Jones

NEW HAMPSHIRE

Sullivan News
9 Odd Fellows Ave.
Concord, N. H.

Verham News
75 Main St.
W. Lebanon, N. H.

NEW JERSEY

A. L. Fairbanks Co.
818 High St.
Burlington, N. J.
A. L. Fairbanks

Record Distributors
1050 Sherman Ave.
Elizabeth, N. J.—Frank Arace

•Edge Ltd.
Route 168
Glendora, N. J.

•Metropolitan Supermarket Services
1601 W. Edgar Rd.
Linden, N.J.—Charlie McAllister

Handleman Co.
1300 Elizabeth Ave., E.
Linden, N. J.—Frank Bernstein

•National Merchandising Services
Stokes Road
Medford, New Jersey

Market Merchandisers Inc.
14-20 Wharton St.
Newark, N.J.

•Garden State Record Dist.
68 West Passaic St.
Rochelle Park, N.J.
Carl Medici

NEW MEXICO

Sandy's Record Sales
4115 Silver SE
Albuquerque, N. M.—Sandy Kahn

NEW YORK

Bee Gee Dist. Co.
28 N. 3rd. St.
Albany, N. Y.—Tom Markowski

•Mershaw Of America
100 Watervliet St.
Albany, N. Y.
Charles Schlang-

•Almor Playtime Co. Inc.
P.O. Box 111
Amsterdam, N.Y.—Albert Hyman

•Platters Inc.
496 Chenango St.
Binghamton, N. Y.
M. Fein—S. Fine

Akorn Housewares Corp.
502 Flushing Ave.
Brooklyn 5, N. Y.

Candy Stripe Records
674 Midwood St.
Brooklyn, N. Y. 11203—Bernard Keil

Met Richmond Record Sales
723 E. 81st St.
Brooklyn 36, N.Y.

Rack Profits
24 E. 52nd St.
Brooklyn, N. Y.—Sy Friedman

Tiechner & Co.
70 Strong St.
Bronx 68, N. Y.

(Continued on next page)

THE FINEST AND
OLDEST RECORD RACK
MERCHANDISER
OF ALL LABELS
IN NORTHERN CALIFORNIA

PARTICULAR ATTENTION
TO SPECIAL ORDERS
FOR REGULAR ACCOUNTS

PROMOTION MERCHANDISE

FAST EFFICIENT SERVICE

PIC-A-TUNE, Inc.

MAIN OFFICE AND WAREHOUSE
1461 Park Ave., Emeryville, Calif. 94608
415-654-0773

Service Branches at:
SANTA ROSA, Liberty 2-2001
SACRAMENTO, 927-1256
FRESNO, 229-1400
SAN JOSE, 259-1237

RACK JOBBERS

Disceries Inc.
861 Washington St.
Buffalo, N. Y.—Carl Glazer

Willard Record Mdse. Corp.
1785 Walden Ave.
Buffalo 25, N. Y.
Ed Jay—Ben Polk

Transcontinent Record Sales
961 Main St.
Buffalo, N. Y.—
Leonard Silver, Steve Brodie

National Bag-O-Tunes, Inc.
224-09 Linden Blvd.
Cambria Heights 11, N. Y.

Tak-A-Toy Inc.
102-05 Northern Blvd.
Corona, N. Y.—Jack Israel

Bocar Sales
124 W. 10th St.
Deer Park, L. I., N. Y.
William Bernstein

Guy Barry Ent.
13 Wesley Drive
East Rockaway, N.Y.

Merco Distributors
750 Stewart Ave.
Garden City, New York
Jack Grossman

Service Housewares
102 4th Ave.
Garden City Park, L. I., N. Y.

Variety House
12 Copeland Ave.
Geneva, N. Y.

Reliable Record Co.
P.O. Box 136
Glen Oaks, N.Y.

Variety Records
15 Bond St.
Great Neck, L. I., N. Y.

New Deal Record Service Corp.
45-18 Court Square
Long Island City, N. Y.
Lou Klayman—Al Levine

Arrow Record Services
P.O. Box 316 Times Sq. Sta.
New York, N. Y. 10036—George Kurtz

Eastern Record Sales & Dist. Inc.
751 Tenth Ave.
New York 19, N. Y.

Kaco Ent.
2444 Throop Ave.
Bronx, N. Y.

Independent Record Promotions
258 W. 18th St.
New York, N. Y. 10011—Larry Guttenplan

National Record Dist.
111 8th Ave.
New York, N. Y.—Ed Stein

New York Record Distributors
15 West 20th St.
New York, N. Y.—Manny Wells

Toy House Of Hudson Valley
Manchester Rd.
Poughkeepsie, N. Y.—Lou Kustas

Finger Lake Home Mdse. Co.
240 Hemingway Dr.
Rochester, N. Y.

Rochester Record Service
196 Ward St.
Rochester, N. Y.—Bill Cyrkin

Statewide Record Sales
119 Rosewood Terrace
Rochester, N. Y.—Len Friedman

Universal Record Sales
1326 Clinton Ave. N.
Rochester, N. Y.

Superior Mdse. Co.
350 Nassau
Roosevelt, L. I., N. Y.

Almor Co.
207 Irving Ave.
Syracuse, N. Y.

Mershaw Of N. Y. Inc.
468 S. Salina St.
Syracuse 3, N. Y.

Platters, Inc.
1411-A W. Genessee St.
Syracuse, N. Y.

Toyman
70 Fallsade Ave.
Yonkers, N. Y.

NORTH CAROLINA

Alexander News Co.
25 Carolina Lane
Asheville, N. C.
Clarence Shuttle—William Alexander

C & M Distributing Co.
100 Southside Drive
Charlotte, N. C.—Ted Conder

Dixie News Co.
2100 Freedom Dr.
Charlotte, N. C.
Tim Braswell—DeWitt Brown

Handleman Co.
320 Isley St.
Greensboro, N. C.—Charles Justice

Rocky Mount News
2900 S. Church Ave.
Rocky Mount, N. C.

J. B. Armstrong News
601 South Broad St.
Winston Salem, N. C.

OHIO

Halmore Distributors
910 N. Main St.
Akron, Ohio—Ross Halamay

Associated Records
101 S. Union
Bedford, Ohio

Valley Enterprises
868 E. Washington
Chagrin Falls, Ohio

Joyce Dist.
1111 Paxton
Cincinnati, Ohio

K. C. Dist.
4508 Homer St.
Cincinnati 27, Ohio

All Label Record Service
1464 West 9th St.
Cleveland, Ohio—Hess Budin

Handleman Co.
6116 Broadway
Cleveland 27, Ohio—Carl Lombardo

Mid West Music
2112 Payne Ave.
Cleveland, Ohio

Modern Record Rack Service
1958 E. 101 St.
Cleveland 8, Ohio
J. W. Burke

Stark Record Service
2321 Scranton
Cleveland, Ohio—Charles Murray

Universal Music
5270 Euclid Ave.
Cleveland, Ohio

Handleman & Co.
550 E. Mound
Columbus, Ohio—Joe Glaser

John J. Getreu & Son Inc.
212 N. 4th St.
Columbus 15, Ohio

Dayton Record Service
2223 Springboro Pike
Dayton 39, Ohio

M. P. Record Co.
5934 Beechwood Dr.
Poland, Ohio

Service Dist.
24 Union St.
Portsmouth, Ohio—Wilburn Carrington

Stark Record Service
1331 Erie St. South
Massillon, Ohio

Hoffman News Agency
25 W. Washington Ave.
Springfield, Ohio

Bartley Co.
921 Brown Ave.
Toledo, Ohio—Richard Bernard

Buckeye Specialties
1102 Summit St.
Toledo, Ohio—Ruth Redfox

Northwest Dist.
1020 Sylvania Ave.
Toledo, Ohio—George LaCorse

Wells Market Service
5053 Stickney Ave.
Toledo 12, Ohio

National Records
Cedar Center Rd.
University Heights, Ohio

Handleman Co.
4018 Simon Rd.
Youngstown 12, Ohio

Samco Co.
1483 S. Ave.
Youngstown, Ohio—Sam Couch

OKLAHOMA

Mid Continent News Co.
Box 985
324 N.W. 11th St.
Oklahoma City 3, Okla.
Don Byers—C. Albro

Southwest Dist. Co.
1159 Madison Ave.
Oklahoma City 3, Okla.
Ken Hensley—M. Woodruff

Oklahoma News Co.
909 W. 23rd St.
Tulsa 7, Okla.
Glenn White—Stan White

OREGON

McDonald Candy Co.
2250 W. B'way
Eugene, Ore.

Patty Day Inc.
326 N. River Rd.
Milwaukie, Ore.

Austin Brothers
9300 N.E. Multnomah
Portland, Ore.—John Turner

Jullan Brown Enterprise
3560 N.E. Kinningsworth
Portland 11, Ore.—Wm. G. Blackburn

Record Mdse. Service
105 N.E. 62nd Ave.
Portland 13, Ore.

Tip Top Music Co.
7501 N.E. Glisan
Portland, Ore.

Paul Jackson Co.
1308 N.W. Park St.
Roseburg, Ore.

Hick Sundries Co.
3060 N. River Rd.
Salem, Ore.

PENNSYLVANIA

Rec O Rac
1011 Baltimore Ave.
East Lansdowne, Pa.—Harry Blaufield

E. P. Records Of Erle
3103 Garland St.
Erle, Pa.

Record Bar Rock
1127 State St.
Erle, Penna.

D&H Distributing Co.
2525 North 7th St.
Harrisburg, Pa.
David Press—Endo Corsetti

Shulman Distributors
912 Henrietta Ave.
Huntington Valley, Pa.

Lebanon News Agency
33 N. 8th St.
Lebanon, Pa.

Triangle News Co.
301 Muson Ave.
McKees Rocks, Pa.—George Fine

Richmark Sales Co.
3806 O'Neil Blvd.
McKeesport, Pa.

Bandstand Record Service
5019 North 5th St.
Phila., Pa.—Jerry Rappaport

Handleman Co.
727 Sedgley St.
Phila., Pa.

I. J. Morgan Co.
511 North Broad St.
Phila, Pa.—Irv Perlman

Slotkin's
4095 Lancaster Ave.
Philadelphia, Pa.—Herb Slotkin

All Brands
213 Galveston Ave.
Pittsburgh 19, Pa.—Robert Roche

Brux Co.
351 Freeport Road
Pittsburgh, Pa.—Charles Wright

Handleman Co.
129-30 First Ave.
Pittsburgh, Pa.

(Continued on next page)

Records for the Family at a Family Price

AN IMPORTANT, PROFITABLE, QUALITY
BUDGET ALBUM LINE

Monaural & Stereo

FAMILY RECORDS CORP.

64 Mechanic St., New Rochelle, N. Y.

Telephone: 914 NE 3-6055

FASTEST GROWING RACK JOBBER IN DETROIT & MICHIGAN

CORNELL RECORDS, INC.

13380 CAPITAL AVE. — Tel: 548-3171
OAK PARK, MICH. (DETROIT) 48237

RACK JOBBERS

Mid-Penn News Agency
100 Eck Circle
Williamsport, Pa.—C. Mayer

RHODE ISLAND

H. V. Papazian & Co.
803 Broadway
East Providence, R. I.
Harold V. Papazian

●Beacon Record Dist.
725 Branch St.
Providence, R. I.—Milton Israeloff

SOUTH CAROLINA

●Brown Sales Co.
1423 Ellerbe St.
Columbia, S. C.—Grady Brown

TENNESSEE

●Knox Record Rack Co.
2000 Western Ave.
Knoxville 21, Tenn.—Sam Morrison

Volunteer Dist. Co.
1108 17th Ave.
Nashville, Tenn.—Weber Parrish

Bill's Music Co.
Union City, Tenn.

TEXAS

●Western Merchandisers
1601 W. Third
P.O. Box 1969
Amarillo, Texas
Dick Williamson—Ed Perry

Nueces News
414 S. Port
Corpus Christi, Texas

●Mershaw of America
1327 Chemical
Dallas, Texas—Kerry Charlton

●Pioneer Dist. Co. of Texas
2406 Irving Boulevard
Dallas 7, Texas
Guy E. Willard

Records Of Dallas Inc.
4912 Vicksburg
Dallas, Texas

●Souvall Dist. Co.
1351 Conant
Dallas, Texas

B & C Record Sales
427 W. San Antonio St.
El Paso, Texas—Herbert Berg

Trinity News
1320 W. B'way
P.O. Box 1806
Ft. Worth 4, Texas—Louis Page

Rec Rac
3438 Leeland
Houston, Texas

Lubbock News
1001 Ave. B
Lubbock, Texas

Melo-D-Lane
3422 Ave. H
Lubbock, Texas—Paul Brink

●Recordland U.S.A.
607 Broadway
Lubbock, Texas—Allan Rosen—Bob Israel

J's Music Land
1209 W. Washington
Midland, Texas

Johnson News Agency Inc.
300 E. Indiana
Midland, Texas

Panhandle Dist. Co.
206 S. Main St.
Perrytown, Texas

Rack Suppliers
519 Gibson St.
Seagoville, Texas—Gene Ackerman

Weiner News Co.
101 Menchaca
P.O. Box 12093
San Antonio, Texas—Stan Weiner

UTAH

●Billinis Distributing Co.
3575 South 700 West
South Salt Lake, Utah—John Billinis

VIRGINIA

Turner Candy Co.
516 Rorer Ave. S.W.
Roanoke, Va.—Andy Turner

Valley Food Co.
Paper Mill Rd.
Box 564
Winchester, Va.

WASHINGTON

●Tip Top Music Co.
529 Dayton
Edmonds, Wash.

●Gordon Sales Co.
100 First Ave. So.
Seattle, Wash.
Stanley Jaffe

Major Record Service
1712 Market St. NW
Seattle, Washington—
Wally Tolles

Pacific Records
1541 Thordyke St.
Seattle, Wash.

●Souvall Dist. Co.
804 6th Ave. S.
Seattle, Wash.—Harry Bradley

United Record Supply
Box 7459, Bitter Lake Station
Seattle 3, Wash.

Austin Brothers Inc.
N 2925 Martin St.
Spokane, Wash.
Bill Austin—Bob Clark

Randle-Brewer Co.
108 W. Mead
Yakima, Wash.

Yakima News Agency
1011 Pitcher St.
Yakima, Wash.—Bill Ring

WEST VIRGINIA

Handleman Co.
5606 McCorkle S.E.
Charleston 4, W. Va.—Bill Hanson

F. P. Kirby
M. B. Dist. Co.
822 6th Ave.
Huntington, W. Va.

H. B. Dist.
4541 Piedmont Rd.
Huntington, W. Va.

WISCONSIN

Arrow Racks
417 S. Barstow St.
Eau Claire, Wisc.

●Record City Record Racks
5600 West North Ave.
Milwaukee, Wisc.—Harold Rietz

Rapid Sales Co.
2702 Monroe
Madison, Wisc.—Rolf Voeglin

●Musical Isle Record Corp.
2429 W. Fond du Lac Ave.
Milwaukee, Wisc.
James Tiedjens

CANADA

Continental Rec. Co., Ltd.
1244 Caledonia Rd.
Toronto 19, Ont.

●Fireco Sales, Ltd.
33 Racine Road
Rexdale, Ont., Canada
Barney G. Ryan

●Western Rack Services Ltd.
120 W. Hastings
Vancouver 3, British Columbia
John MacMillan

MACHINE SHOPS

●●Western Record Pressers Association

●●Adams & Associates
1062 N. Orange Grove
Hollywood, Calif.

American Packaging Co.
P. O. Box 71743
Florence Branch
Los Angeles 1, Calif.

Aragon Products, Inc.
72 Concord St.
Newark 12, N. Y.

●●Beckstrand Hoffman Machine & Tool
4126 E. Anaheim
Long Beach, Calif.

●●Coast Export Co.
2846 W. Pico Blvd.
Los Angeles, Calif.

Eckstein Recording Products Co.
8637 W. Washington Blvd.
Culver City, Calif.

Finebilt Mfg. Co.
2846 W. Pico
Los Angeles, Calif.

Garden City Mfg.
Garden City, L. I.

Garden States Hydraulics Corp.
189 Mail Dr.
North Plainfield, N. J.

Holland Electroplating Equipment
475 Keap St.
Brooklyn, N. Y.

Indus Manufacturing Co.
Indianapolis, Ind.

●●Johnson Machine & Tool
1702 W. 134th St.
Gardena, Calif.

King Records and Royal Plastics
1540 Brewster Ave.
Cincinnati, Ohio

M G M Records
Bloomfield, N. J.

Palmer M. May
3117 Cambridge Road
Charlotte, N. C.

RCA Victor
Hollywood, Calif.

RCA Victor
501 N. LaSalle St.
Indianapolis, Ind.

RCA Victor
Route 46, Franklin Ave.
Rockaway, N. Y.

RCA Victor
155 E. 24th St.
New York 10, N. Y.

Standard Paper Box Machine
476 Broome St.
New York, 13 N. Y.

Standard Tool & Die
Kearny, N. J.

(Continued on next page)

AUTHENTIC TAHITIAN RECORDS

New LP's

OTUITUI-TAHITI Mono \$4.98
Hit Parade of Tahiti Stereo \$5.98

New EP's

TAHITIAN LANGUAGE RECORDS

Unique conversation course \$2.00
PAUMOTU! Recorded in Tahiti
by Teaitu Mariterangi \$2.00

Best Selling LP's

DRUMS OF BORA BORA Mono \$4.98
TAMURE! TAMURE! Stereo \$5.98

and
TA'U TAHITI TAHITI FETE!
BEAT OF TAHITI TAHITI DANCES
BEACHCOMBER SERENADE
Mono \$4.98

Send for record Catalogue.

THE STECHESON classified SONG DIRECTORY

over 100,000 titles—400 categories

Steve Sholes of RCA says: "Every one of our A&R men has this book on his desk at all times."

Indispensable to the record business.

Send for brochure.

Price: \$25.00 in the USA

CRITERION MUSIC CORPORATION

6124 Selmo Ave. Hollywood 28, Cal.
Michael H. Goldsen, Pres.

SUPERSONIC SOUND
FROM
JET SET RECORDS

JET SET RECORDS, INC.
519 Davis Bldg.
Washington, D.C. 20006

A SERVICE FOR THE RACK JOBBERS

☆☆☆

All Types of INDEX STRIPS and PRICE LABELS
"TAILOR MADE" for your needs.

SEND FOR A COMPLETE BROCHURE TODAY.

★

STAR TITLE STRIP COMPANY, INC.

842 Western Avenue Area Code 412 231-4314 Pittsburgh, Pa. 15233

ALBUM JACKET MANUFACTURERS

©Independent Record Mfrs. Association
©Western Record Pressers Association

AA-1 Products
245 7 Ave.
New York, N. Y.

Bert Co. Press
9862 Santa Monica Blvd.
Los Angeles 29, Calif.

Calcraft Album Co. Inc.
1211 N. Western
Los Angeles 29, Calif.

Chicago Album Specialty Co.
426 S. Clinton
Chicago, Ill.

The Chromart Co.
711 Spring Garden St.
Philadelphia, Pa.

Coburn & Co.
732 South Federal St.
Chicago 5, Illinois

Cole Corp.
823 S. Wabash Ave.
Chicago, Ill.

Community Press
6047 Woodland Ave.
Philadelphia, Pa.

●●Container Kraft
801 E. 61 St.
Los Angeles, Calif.

County Box & Albums
201 S. 2nd Ave.
Mt. Vernon, N. Y.

Crown Album Corp.
1217-1241 Carpenter St.
Philadelphia, Pa.

Fi-Hi Rec. Saver
P. O. Box 6417
Cleveland, Ohio

Gailyn Packaging
1475 Southern Blvd.
New York, N. Y.

Gem Album Co.
1119 Worthen St.
New York 59, N. Y.

●Globe Albums
1255 Oak Point Ave.
New York 59, N. Y.

Imperial Paper Box Corp.
252 Newport St.
Brooklyn 12, N. Y.

Imperial Paper Box Corp.
733 W. Heary
Indianapolis, Ind.

King Records
1540 Brewster
Cincinnati, Ohio

●Modern Album & Finish. Co.
119-01 22 Ave.
College Point, N. Y.

Modern Album & Finish. Co.
2011 S. Third St.
Terre Haute, Ind.

Modern Album & Finish. Co.
3116 Van Owen St.
Burbank, Calif.

Queen City Album Co.
7200 Colerain Ave.
Cincinnati, Ohio

J. Radley Metzger Co.
119 E. 38th St.
New York, N. Y.

Record Packaging Corp.
1 Ivy Hill Rd.
Bklyn, 11, N. Y.

Record Printing Co.
1418 W. Florence Ave.
Los Angeles, Calif.

Southern Envelope Mfrs.
794 Berry Rd.
Nashville, Tenn.

Strathmore Sales
56 S. 11th St.
Brooklyn, New York

T. Packaging
214 Sullivan St.
New York, N. Y.

U.S. Envelope Co.
3 Ann St.
Hartford 1, Conn.

Wakefield Industries
Lowell,
Mass.

TRADE ASSOCIATIONS

American Guild of Authors & Composers (AGAC)
158 W. 55 St.
New York, N. Y. PL 7-8833

American Guild of Variety Artists (AGVA)
551 Fifth Ave.
New York, N. Y. TN 7-5600

Assoc. of Record Merchants & Dist. (ARMADA)
7600 Wayzata Blvd.
Minneapolis, Minn. 544-4201

Country Music Assoc. (CMA)
801-16th Ave. South
Nashville, Tenn. 615-244-2840

Electronic Industries Assoc.
1721 De Sales St., N.W.
Washington 36, D.C.

Int'l Record & Music Mens Club (IRMMC)
c/o Walter Hofer
221 West 57th St.
New York, N. Y. JU 2-5030

Magnetic Recording Industry Assoc. (MRIA)
See Electronic Industries Assoc.

Music Operators of America (MOA)
228 N. La Salle St.
Chicago 1, Ill. 726-2810-1

Music Publishers Protective Assoc. (MPPA)
460 Park Ave.
New York, N. Y. PL 1-1930

National Association of Retail Record Dealers (NARRD)

Joe Goldberg
Variety Record Shop
Wheaton Plaza, Md.

National Assoc. of Music Merchants (NAMM)
222 W. Adams
Chicago 6, Ill. AN 3-0679

Nat'l Academy of Recording Arts & Sciences (NARAS)
New York: 21 W. 58 St., PL 5-1535
Hollywood: 1741 Ivar Ave., HO 5-2124
Chicago: 46 E. Walton, MI 2-6465
Nashville: Box 6155, Acklen Station
255-6535

Nat'l Assoc. of Radio Announcers (NARA)
2332 South Michigan
Chicago, Ill. 326-5080

Nat'l Assoc. of Record Merchandisers (NARM)
Suite 703 Trianon Building
20 Conshohocken State Rd.
Bala Cynwyd, Pa. 19004

Professional Music Men, Inc.
1270 Sixth Ave.
New York 20, N. Y. CO 5-7362

Record Industry Assoc. of America (RIAA)
1 E. 57 St.
New York 22, N. Y. MU 8-3778

Record One-Stop Assoc. (ROSA)
Galaxy One Stop
3236 Lawson Blvd.
Oceanside, New York 516-OR 8-6180

Queen City

OFFERS A
**COMPLETE
PACKAGE**

PURE
VINYL
RECORDS

STOCK JACKETS

CUSTOM DESIGNING

FABRICATING

SHRINK WRAPPING

CUSTOM
DESIGNED
JACKETS

LABELS

MASTERING

PROCESSING

CUSTOM PRESSING

WRITE FOR OUR ILLUSTRATED CATALOG
CONTAINING PACKAGE PRICES.

QUEEN CITY ALBUM COMPANY
7200 COLERAIN AVE. CINCINNATI, OHIO
PHONE: 513-931-3232

RECORD SLEEVE MFRS.

●Independent Record Mfrs. Assn.
●●Western Record Pressers Assn.

P. L. Andrews
Andrews Rd.
Hicksville, L. I., N. Y.

Alemo Ltd.
737 Drake St.
New York 59, N.Y.

Arlington Sales
1334 Webster Ave.
Bronx, N. Y.

Berto Press
4862 Santa Monica Blvd.
Los Angeles, Calif.

Chuiterman Paper Co.
517 W. 21st St.
Chicago 8, Ill.

Cohoes Envelope Co.
Cohoes, N. Y.

Cole Corp.
823 S. Wabash Ave.
Chicago, Ill.

●●Container-Kraft
Carton & Paper Supp. Co.
801 E. 61st St.
Los Angeles, Calif.

Creative Sound Prod.
9000 Sunset Blvd.
Los Angeles, Calif. 90069

Crown Album Corp.
1217 Carpenter St.
Philadelphia, Pa.

D & G Transparent Bag Co.
550 Fifth Ave.
New York, N. Y.

Diamond Cellophane
2724 S. Michigan
Chicago, Ill.

Dual Phono Record Env. Co.
148 Broadway
Melrose Park, Ill.

Equitable Paper Bag Co.
45-50 Van Dam
Long Island City, N. Y.

Fine-Tone
7111 20th Ave.
Brooklyn, N. Y.

●Globe Albums
1255 Oak Point Ave.
New York 59, N. Y.

RECORDING STUDIOS

- Independent Record Mfrs. Assn.
- Western Record Pressers Assn.

A-1 Sound Studios
234 W. 56th St.
New York, N. Y.

• A & R Recording, Inc.
112 West 48th St.
New York, N. Y.

Academy Record Co.
3035 W. Fullerton
Chicago, Ill.

Agency Recording
20 N. Wacker
Chicago, Ill.

Air Check Services
1743 W. Nelson
Chicago, Ill.

Allegro Sound Studios, Inc.
1650 Broadway
New York, N. Y.

Austin Drew Inc.
P.O. Box 131
White Plains, N. Y.

Tommy Allsup
Box 6406, 5600 E. Country Rd.
Odessa, Texas

American Music
Bennie Dillon Building
Nashville, Tenn.

American Recording Co.
11386 Ventura
N. Hollywood, Calif.

Apex
1023 N. La Brea Ave.
Hollywood, Calif.

Artists Recording Co.
2931 W. Touhy
Chicago, Ill.

Ashna Music
115 3rd Ave. N.
Nashville, Tenn.

Assoc. Rec. Studios
723 7 Ave.
New York, N. Y.

Atlanta Sound
524 Plasters Ave. N.E.
Atlanta, Ga.

Atlantic Recording Studio
11 W. 60th St.
New York, N. Y.

Audio Arts
5607 Melrose Ave.
Hollywood 38, Calif.

Audio Craft
11359 S. Lothar
Chicago, Ill.

Audio Engineering Assoc.
477 Alexander Rd.
Elmhurst, Ill.

Audio Recording
Four New Hyde Park Rd.
Franklin Square, Long Island, N. Y.

Audio Recording
2227 Fifth Ave.
Seattle, Washington

Audio Recorders of Ariz.
3830 N. 7th St.
Phoenix, Ariz.

Audio Techniques
247 W. 46th St.
New York, N. Y.

Austin McCoy's Studio
13221 S. Avalon
Los Angeles, Calif.

Authentic Recordings
110 S. Dearborn
Chicago, Ill.

Balkan Music Co.
6917 Cermak
Berwyn, Ill.

Barney Kugel Sound
161 E. Grand
Chicago, Ill.

Bell Sound Studios
237 West 54th St.
New York, N. Y.

Beltone Recording Corp.
4 West 31st St.
New York, N. Y.

Belvedere Recording Studio
319 W. 48th St.
New York, N. Y.

Boulevard Recording Studios
632 N. Dearborn
Chicago, Ill.

Bradley's Studios
804 16 Ave., S.
Nashville, Tenn.

Broadway Recording Studios
1697 Broadway
New York, N. Y.

Capitol Records
Capitol Tower
Hollywood, Calif.

Capitol Records
806-16th Avenue S.
Nashville, Tenn.

Capitol Records, Inc.
151 West 46th St.
New York, N. Y.

Dick Charles Recording Studios
729 7th Ave.
New York 19, N. Y.

Chess Record Corp.
2120 S. Michigan
Chicago, Ill.

Cinematation
Paul-Helen Building
Iowa City, Iowa

Coast Recording
960 Bush St.
San Francisco, Calif.

Coast Recording
2534 W. Pico
Los Angeles, Calif.

Columbia Recording
630 No. McClurg
Chicago, Ill.

Columbia Records
799 Seventh Ave.
New York, N. Y.

Columbia Records
6121 Sunset Blvd.
Hollywood, Calif.

Conway Recorders
1441 No. McCadden Pl.
Hollywood, Calif.

Cook & Associates Recorders
3905 W. Stauson Ave.
Los Angeles 43, Calif.

Concert Classics
111 W. 57th St.
New York, N. Y.

Criteria Recording Studios
1755 N.E. 149th St.
Miami 61, Fla.

Crystal Studios
36 W. Randolph
Chicago, Ill.

Custom
4 Column St.
Greenville, S. C.

Custom Recorders
5151 Strohm
Los Angeles, Calif.

Decca Records
50 West 57th St.
New York, N. Y.

8 TRACK

4 TRACK

3 TRACK

2 TRACK

MONO



COLUMBIA RECORDING STUDIO HOLLYWOOD

Phone HOLLYWOOD 62481

(Continued on next page)

RECORDING STUDIOS

Decca Records
803-16th Avenue S.
Nashville, Tenn.

Delsey Sound Studios
2509 N. Front St.
Philadelphia, Pa.

Delta Recording Corp.
236 W. 55 St.
New York, N. Y.

Delta Records
4304 W. Fullerton
Chicago, Ill.

Delta Recording Center
3225 West Fourth St.
Fort Worth, Texas

Deryck Waring Recordings
37 E. 49 St.
New York, N. Y.

Dial Records
905-16th Avenue S.
Nashville, Tenn.

Dulcet
4334 Stern Shoks
Los Angeles, Calif.

Dynamic Sound
One Woodcrest Rd.
Hicksville, N. Y.

Electrovox Recording Studios
5546 Melrose Ave.
Hollywood, Calif.

Empire Broadcasting
480 Lexington Ave.
New York, N. Y.

Fidelity Recording Studios
1354 Vine
Los Angeles, Calif.

Film City
1485 Vine St.
Los Angeles, Calif.

Filmtown
1354 Vine St.
Los Angeles

Fine Recording Co., Inc.
118 West 57th St.
New York, N. Y.

Fink Recording
2732 Beachmont
Norfolk, Va.

Fortune Recordings
3942 3rd Ave.
Detroit, Mich.

Gaity Record Studio
1501 Newton Ave.
Minn. 11, Minn.

Galewood Records
333 N. Michigan
Chicago, Ill.

Garrison Recording Studios
6252 Santa Monica Blvd.
Hollywood, Calif.

Globe Recording
230 N. Michigan
Chicago, Ill.

Globe Recording Studio
420 A Broadway
Nashville, Tenn.

Golden State Recorders
665 Harrison St.
San Francisco, Calif.

●●Gold Star Recording Studios
6252 Santa Monica Blvd.
Hollywood, Calif.

Gotham Rec. Corp.
2 West 46th St.
New York, N. Y.

Hall Recording
307 S. Wabash
Chicago, Ill.

Harmony Recorders
1479 N. Vine St.
Hollywood, Calif.

Hartnett National Music Studios
210 West 42nd St.
New York, N. Y.

Hickory Records
25-10 Franklin Rd.
Nashville, Tenn.

●●Hollywood Central Studios, Inc.
1538 Cahuenga Blvd.
Hollywood, Calif.

Hollywood Recording Guild
166 No. La Brea
Los Angeles, Calif.

Ind-O-Pro Recording Assocs.
1733 B'way
New York, N. Y.

International Recording
5619 W. Division St.
Chicago, Ill.

International Sound, Inc.
5539 Sunset Blvd.
Hollywood 28, Calif.

J.A.C. Recording Service
152 West 58th St.
New York, N. Y.

Jay Jay Recording
2452 So. Kedzie
Chicago, Ill.

Jaysina Ent.
143 W. 51 St.
New York, N. Y.

Jimmy Jones
148 No. Pasadena
Pasadena, Calif.

Joy Recording Studios
111 E. Ontario
Chicago, Ill.

KM Studios
Palmer Hill Road
Port Crane, New York

Knickerbocker Studios
146 W. 47th St.
New York, N. Y.

King Records
1540 Brewster Ave.
Cincinnati, Ohio

Kiski Recording Co.
Box 116
North Apollo, Pa.

Little Nashville Record Corp.
45 Allen Drive
Charleston Hgts., South Carolina

Location Recording Service
2201 W. Burbank
Burbank, Calif.

Lynn Oliver Studios
250 W. 89th St.
N.Y.C.

MacQuarrie Ent.
2696 Santa Rosa
Altadena, Calif.

C. P. MacGregor
729 So. Western
Los Angeles, Calif.

Manhattan Sound Corp.
New York, New York

Mastertone Recording Studios
130 West 42nd St.
New York 36, N. Y.

M.B.S. Recording Studios
228 S. Wabash
Chicago, Ill.

Metcalfe's (Thesaurus)
116 West Franklin St.
Dayton, Ohio

Mills Recording Co.
161 N. Michigan
Chicago, Ill.

Mirasound Studio
145 W. 47th St.
New York, N. Y.

Monument Records
530 W. Main St.
Hendersonville, Tenn.

Mass Recording Studios
1908-1910 California St.
Omaha 2, Nebr.

Music City Recorders
821 19th Ave. S.
Nashville, Tenn.

Nashville, West
505 Melrose
Hollywood, Calif.

National Recording Corp.
2871 E. Ponce De Leon Ave.
Decatur, Ga.

Nola Studios
111 West 57th St.
New York, N. Y.

Nugget Studios
Finnen Rd.
Nashville, Tenn.

O-D-O Recording
254 West 54th St.
New York 19, N. Y.

Olmsted Sound Studios, Inc.
1 East 54th St.
New York, N. Y.

Orbison Associates
530 W. Main St.
Nashville, Tenn.

Orbit Radio
P.O. Box 1644
Louisville, Ky.

Original Sound Studios
7120 Sunset Blvd.
Hollywood, Calif.

Park Recording
200 East 66th St.
New York, N. Y.

Parliament Records
Box 341-A R.D.2
Parkesburg, Pa.

Pepper Sound Studio
62 South Diana
Memphis 4, Tenn.

Petrucchi & Atwell
21 Carver Rd.,
Newton, Mass.

Norman Petty Studios
Clovis, N. Mexico

Pharaoh Records
P.O. Box 969
McAllen, Texas

Sam Phillips Studios
639 Madison Ave.
Memphis, Tenn.

Sam Phillips Studios
319 7th Ave. No.
Nashville, Tenn.

Phonotone Recording Service
176-11 Jamaica Avenue
Jamaica, N. Y.

Michael Piorek
625 Burnside Ave.
Bridgeport, Conn.

Plastic Products
1746 Chelsea Ave.
Memphis 7, Tenn.

Plaza Sound Studios
55 W. 50th St.
New York, N. Y.



LET US
DEAL YOU
THE
WINNING
HAND . . .

FINE TONE AUDIO PRODUCTS CO., INC. 7111 20th Ave., Brooklyn 4, New York
(212) CL 6-7876-7-8

HITS ARE MADE
AT THE
**VIRTUE
RECORDING
STUDIO**

1618 North Broad
Philadelphia, Pa. 19121
Frank Virtue 215-PO 3-2825

**ROSSI ENT.
RECORDING STUDIO**

- ★ 2 Track Ampex ★ 3 Echo System Used
- ★ Dealer for Hagstrom Guitars & Hilgen Amps.
- ★ Guitars Expertly Repaired

PHONE ES 2-2605
2005 West 8th St.
Brooklyn 23, New York

A-1 SOUND STUDIOS INC.

234 W. 56th St.
New York 19, N.Y.
CI 6-3594

**3 & 4 Track Selsync
Master Recording**

**CELEBRATING ANOTHER
YEAR OF MAKING TOP HITS
FOR OUR CLIENTS**

**REASONABLE RATES!
PERSONAL ATTENTION!
HERB ABRAMSON, PRES.**

**ALLEGRO
SOUND STUDIOS
INC.**



COMPLETE FACILITIES AVAILABLE
UP TO 4 TRACKS!

• DAY & NIGHT RECORDING •

1650 BROADWAY
NEW YORK, N. Y. 10019
Circle 6-5560

RECORDING STUDIOS

●●Radio Recorders
7000 Santa Monica Blvd.
Hollywood, Calif.

R.J. Recorders
6359 Selma Ave.
Hollywood, Calif.

RCA Custom Record Sales
155 East 24th Street
New York 10, New York
MU 9-7200

RCA Custom Record Sales
800 17th Avenue South
Nashville 3, Tennessee
AL 5-5781

RCA Custom Record Sales
445 North Lake Shore Drive
Chicago 11, Illinois
WH 4-3215

RCA Custom Record Sales
6363 Sunset Blvd.
Hollywood 28, California
HO 1-9171

Reco-Art Sound Recording
212 N. 12th St.
Philadelphia 7, Pa.

Record Broadcast
237 S. Bent. Ave.
San Maros, Calif.

Recordings, Inc.
1130 E. Cold Spring Lane
Baltimore 12, Md.

Recording of Nashville
115 1/2-3rd Avenue N.
Nashville, Tenn.

Recording Studios, Inc.
Capitol Theatre Bldg.
1639 Broadway
New York, N. Y.

Reeves Sound Studios, Inc.
304 East 44th St.
New York, N. Y.

Regent Sound Studios
25 West 56th St.
New York, N. Y.

Replica Transcriptions
37 West 57th St.
New York, N. Y.

Richcraft Recording
2314-63rd St.
Brooklyn, N. Y.

Rite Records Productions, Inc.
3930 Spring Grove Ave.
Cincinnati 23, Ohio

Rockhill Recording
18 East 50th St.
New York, N. Y.

Rol Recording
821-19th Avenues
Nashville, Tenn.

Ronson Recording
1521 Texas Ave.
Lubbock, Texas

Ross Ent.
2005 W. 8th St.
Brooklyn 23, N.Y.

Sanders Rec. Studios, Inc.
167 West 48th St.
New York, N. Y.

Sara Sound Studios
123 Water St.
Sauk City, Wisc.

Seely John Associates
1717 N. Highland
Los Angeles, Calif.

Sheldon Recording Studios
1725 N. Wells
Chicago, Ill.

Shelley Products
220 Broadway
Huntington Station, L. I., N. Y.

Fletcher Smith Studios
259 S.W. 21st Terrace
Ft. Lauderdale, Fla.

Sonic Arts
333 N. Michigan
Chicago, Ill.

Sonico Recording Studios
319 7th Ave.
Nashville, Tenn.

Sound Makers
6 W. 57th St.
New York, N. Y.

Sound Studios
230 N. Michigan
Chicago, Ill.

Sound Unlimited
906 Lynn Drive
Valley Stream, New York

Soundings Recording Service
215 East 12th St.
New York, N. Y.

Spectra-Sound, Inc.
6110 Santa Monica Blvd.
Hollywood 38, Calif.

Star Production
398 Main St.
Orange, N. J.

Stark Records
628 South St.
Mount Airy, N. C.

Starday Sound Studios
Dickerson Rd.
Madison, Tenn.

Stea-Phillips
781 7th Ave.
New York, N. Y.

Stereo Masters
5538 Melrose
Los Angeles, Calif.

Stereo-Sonic
226 S. Wabash
Chicago, Ill.

Stereo Sound Studios
238 East 26th St.
New York, N. Y.

Studio & Artists
6087 Sunset Blvd.
Hollywood, Calif.

Studio Center
1721 B'way
N.Y.C.

Studio F
6021 W. Sunset
Los Angeles, Calif.

Studio 3 Inc.
146 East 57th St.
New York 22, N. Y.

Sumet Sound Studios
5652 Daniels Ave.
Dallas, Texas

Sunset Sound Recorders
6650 Sunset Blvd.
Los Angeles, Calif.

Swallow Studios
434 E. Main, Box 506
Ville Platte, La.

Talentmasters
126 West 42nd St.
New York, N. Y.

Ter-Mar Recording Studios
2120 S. Michigan
Chicago 16, Ill.

Texas Sound Studios
506 W. Hildebrand Ave.
San Antonio 12, Texas

Titra Sound Corp.
1600 Broadway
New York, N. Y.

Todd Recording
1719 Westend Ave.
Nashville, Tenn.

Tower Sound Studios
1697 Broadway
New York, N. Y.

David Trimble
205 West 57th St.
New York, N. Y.

True Tone Rec. Co.
160 West 73rd St.
Studio 4-F
New York, N. Y.

Ultimate Sound Recorders
7619 W. Sunset Blvd.
Hollywood, Calif.

United Recording Co. of Nevada
3143 Industrial Rd.
Las Vegas, Nev.

United Recording Corp.
6052 Sunset Blvd.
Hollywood, Calif.

United Rec. Labs, Inc.
681 Fifth Ave.
New York, N. Y.

Universal Recorders
6757 Hollywood Blvd.
Hollywood, Calif.

Universal Recording
46 E. Walton
Chicago, Ill.

Universal Recording Studios
26 Colton Ave.
W. Springfield, Mass.

Variety Sound Corporation
225 West 46th St.
New York 36, N.Y.

Virtue Recording Studio
1618 N. Broad St.
Phila., Pa.

Wally Helder Recording
6373 Selma Ave.
Hollywood, Calif.

John W. Welland
16 E. 23rd St.
New York, N. Y.

W.R.S. Recording Labs
1479 Vine St.
Hollywood, Calif.

WTTW Recording Services
5400 North Saint Louis
Chicago, Ill.

Webb Recording
812 N. Dearborn
Chicago, Ill.

West Coast Sound
1721 N. Vermont
Los Angeles, Calif.

Western Recorders
6000 Sunset Blvd.
Hollywood, Calif.

World Artists United
1595 Broadway
New York, N. Y.

World Pacific Studio
8175 W. 3rd
Los Angeles, Calif.

Wye Productions
625 Warwick Ave.
Warwick, R. I.

Wynwood Music
102 E. Fairfax St. (P.O. Box 505)
Falls Church, Va.

BROOKS ARTHUR



RECORDING STUDIO
Serving the Record Industry

- MASTERING
- DEMO SESSIONS
- MONAURAL OR STEREO PHONIC
- 4 TRACK RECORDING
- ON LOCATION RECORDING

Stereo-Sonic

RECORDING CORPORATION
226 S. Wabash, Chicago, Ill.
Phone: 922-0132

SOUND? SERVICE?

For Best Sound
and Service
Leading Independents
use

*associated
recording
studios*

723 Seventh Ave. N. Y. C. 19
Circle 5-7640

RECORDING IN HOLLYWOOD?

For a great new sound at the most reasonable rates try:

R. J. RECORDERS

Time	Live Recording & Overdubbing			Dubdown Editing Playback
	Mono	2/track	3/track sel-sync	
9:00 am—6:00 pm	\$15.00	\$17.50	\$20.00	\$15.00
6:00 pm—Midnight Saturday until 6:00 pm	\$17.50	\$20.00	\$22.50	\$17.50
Midnight Saturday from 6:00 pm Sundays & Holidays	\$20.00	\$22.50	\$25.00	\$20.00

Engineer: Phil A. Yeend

demonstration records recorded at R. J. RECORDERS sent upon request.

R. J. RECORDERS 6359 Selma Avenue, Hollywood, Calif. 90028 area code
213-469-3525

Telephone:
90028 area code
213-469-3525

ASCAP PUBLISHERS

- A Bar 3 360 N. Camden Beverly Hills, Cal.
A-H 1501 Broadway, N.Y.C.
A.M.C. 30 W. 60th St., N.Y.C.
AMG 309 S. Broad St., Phila., Pa.
A-M 609 Fifth Ave., Apt. 101 W. 55th St., N.Y.C.
AALborg 10 E. 49th St., N.Y.C.
Aadvark 30 Rockefeller Pl., N.Y.C.
Abbey 6533 Hollywood Blvd., H'wood, Calif.
Abcoa 507 Fifth Ave., N.Y.C.
Ablene 100 W. 42nd St., N.Y.C.
Acacia 292 Madison Ave., N.Y.C.
Academy 710 W. Maple Dr., Beverly Hills, Cal.
Acamor 233 E. 32nd St., N.Y.C.
Accadia 9926½ Robbins Dr., Beverly Hills, Calif.
Accolade 351 Veteran Ave., L.A., Cal.
Active 3170 S. W. 8th, Miami
Addax c/o Leeds 322 West 48th, N.Y.C.
Ad-Lib 6300 Craner Ave., N. Hollywood
Adrienne 222 West 83rd St., N.Y.C.
Ad-Staff 9122 Sunset Blvd., Hollywood
Adams, George 681 Fifth., N.Y.C.
Adams, Stanley 3 Wood Pl., Great Neck, L.I., N.Y.
Adamson 420 S. Beverly Dr., Beverly Hills, Cal.
Adaros 170 S. Elm St., Denver, Colo.
Active 322 W. 48th St., N.Y.C.
Adler, Henry 136 West 46th St., N.Y.C.
Admiral 6240 Tujunga Ave., N. H'wood, Cal.
Admont 2 West 45th St., N.Y.C.
Advanced 488 Madison Ave., N.Y.C.
Advertisers 54 West Randolph St., Chicago
Agrun 1619 Broadway, N.Y.C.
Ahlert-Burke 15 E. 48th St., N.Y.C.
Ahlert, Fred 15 E. 48th St., N.Y.C.
Aida 161 West 54th St., N.Y.C.
Alamo 1619 Broadway, N.Y.C.
Alanbee c/o Eli Parker 321 S. Beverly Dr., Beverly Hills, Cal.
Alanna 1409 Fifth Ave., Pittsburgh, Pa.
Alba 1650 Broadway, N.Y.C.
Alber 1428 N. Havenhurst, H'wood, Calif.
Albino 400 Seventh Ave., Bklyn, N.Y.C.
Album 123 West 57th St., N.Y.C.
Albums 1111 N. Evergreen St., Burbank, Calif.
Aldo 2046 East 21st St., Bklyn, N.Y.C.
Alexis 408 West 57th St., N.Y.C.
Alfred 530 Fifth Ave., N.Y.C.
Allegro P.O. Box 11371, L.A., Cal.
Allied 1619 Broadway, N.Y.C.
All-World 1329 S. Redondo Blvd., L.A., Cal.
Almadin 16 West 90th St., N.Y.C.
Almanac 10 Columbus Circle, N.Y.C.
Alpene 150 West 55th St., N.Y.C.
Alpep 2076 Union Ave., Memphis, Tenn.
Ama 1650 Broadway, N.Y.C.
Ambassador 480 Lexington Ave., N.Y.C.
Amelia 319 E. 48th St., N.Y.C.
American Academy of Music 1619 Broadway, N.Y.C.
"AMI" Educational Service 6341 W. 6th St., L.A., Calif.
Amco 1501 Broadway, N.Y.C.
Amigo 1851 Brunner St., Phila., Pa.
Amphion 1001 N. Bundy Dr., L.A., Cal.
- Amrita 200 W. 57th St., N.Y.C.
Amsam 400 Madison Ave., N.Y.C.
Anchor 58 W. 48th St., N.Y.C.
Andante 207 East 31st St., N.Y.C.
Andor 6381 Hollywood Blvd., H'wood, Cal.
Andover 10 Columbus Circle, N.Y.C.
Andrea 1650 Broadway, N.Y.C.
Andrew 119 West 57th St., N.Y.C.
Androzso-Thompson 92415 S. Michigan, Chicago, Ill.
Aneres 117 West 48th St., N.Y.C.
Angelica Box 2630, H'wood, Cal.
Angry 2553 Bedford Ave., N.Y.C.
Ankerford 1619 Broadway, N.Y.C.
Ann 1853¾ Canyon Dr., H'wood, Cal.
Annavic c/o Ivan Mogull 1619 Broadway, N.Y.C.
Annie-Earl 200 West 57th St., N.Y.C.
Anro c/o Eldee 33 West 42nd Street, N.Y.C.
An-Sound 6018 Henderson St., Chicago, Ill.
Antar 1651 Cosmo St., H'wood, Cal.
Antenna 185 N. Wabash Ave., Chicago
Anthony 8907 Wilshire Blvd., Beverly Hills, Cal.
Antopal P.O. Box 76, Old Chelsea Sta. N.Y.C.
Anton 449 S. Beverly Dr., Beverly Hills, Calif.
Antone 6 Carter Pl., Woburn, Mass.
Anthony, Frank c/o Frank Madden 34 Oldis St., Rochelle Park, N.J.
Anvil 57 West 56th St., N.Y.C.
Apollo 301 West 41st St., N.Y.C.
Applesed 200 West 57th St., N.Y.C.
Apple Valley 3489 Wonderview Dr., H'wood, Cal.
April 1650 Broadway, N.Y.C.
Apt 150 West 55th St., N.Y.C.
Aqua 2505 Highland Ave., Broomall, Pa.
Aragain 1003 Sunset Vine Tower Bldg., H'wood, Cal.
Arbee 475 Fifth Ave., N.Y.C.
Arcade 2733 Kensington Ave., Phila.
Arcadia c/o Rex Productions 8715 West 3rd St., L.A., Cal.
Arce 153 Manhattan Ave., N.Y.C.
Arch 25 West 56th St., N.Y.C.
Archer 30 Van Cortlandt Park S., Bronx, N.Y.
Arcot 250 West 57th St., N.Y.C.
Ardmore 1750 N. Vine St., H'wood, Cal.
Argosy 631 Orienta Ave., Mamaroneck, N.Y.
Aria 2345 Linwood Ave., No. 1E, Ft. Lee, N.J.
Arista 1650 Broadway, N.Y.C.
Arkayem 7 Winthrop Ave., Yonkers, N.Y.
Arko c/o Edwin H. Morris & Co., 31 W. 54th St., N.Y.C.
Arlou 609 Fifth Ave., N.Y.C.
Arndt, Nola 151 West 51st St., N.Y.C.
Arnel c/o John S. Kelley, Jr., 1540 Brewster Ave., Cincinnati, O.
Arovox (Leona Music) 620 West 51st St., N.Y.C.
Arpege c/o Gold, Mason & Co., 515 City National Bank Bldg., Beverly Hills, Calif.
Arrow 2576 Superior Ave., Cleve, Ohio
Arthur 125 Ocean Pkwy, Brooklyn, N.Y.
Arthur 1614 Argyle Ave., H'wood, Cal.
Artists 250 N. Canon Dr., Beverly Hills, Cal.
Arvon 7039 Sunset Blvd., H'wood, Cal.
- Asa 6920 Sunset Blvd., H'wood, Cal.
Ascher, Emil 745 Fifth Ave., N.Y.C.
Asco 9229 Sunset Blvd., Los Angeles, Calif.
Ascot-Jolon c/o Kip Records 45 West 39th St., N.Y.C.
Ascot c/o Frank Thomas 33 West 42nd St., N.Y.C.
Ashwyn c/o Edna Lewis 430 East 63rd St., N.Y.C.
Aspen c/o Valando 22 West 48th St., N.Y.C.
Aspen P.O. Box 8787, Denver, Colo.
Asset 1650 Broadway, N.Y.C.
Associated Students of Stanford University Old Union Bldg., Stanford, Calif.
Astor 103 Union St., Lodi, N.J.
Astron 1595 Broadway, N.Y.C.
Astronaut 2550 Briggs Ave., Bronx, N.Y.
Athwarn 488 Madison Ave., N.Y.C.
Atlas 488 Madison Ave., N.Y.C.
Atrium 1631 Broadway, N.Y.C.
Atterbury 7520 N. Gravenstein, Portland, Ore.
Auburndale c/o Mack H. Kay, 194-06A 39th Ave., Flushing, N.Y.
Audio 6226 Yuca St., Hollywood, Calif.
Audubon 119 West 57th St., N.Y.C.
Aut 6830 Pacific View, Los Angeles, Calif.
Avant Garde 850 7th Ave., N.Y.C.
Avalona 264 West 73rd St., N.Y.C.
Avaris, see Arch
Avas 250 West 57th St., N.Y.C.
Avenue 551 Dutch Valley Rd. N.E., Atlanta, Ga.
Ayuga 258 S. Bedford Dr., Beverly Hills, Cal.
Azar, John E. 232 West 48th St., N.Y.C.
Aztec c/o Bregman, 1428 N. Havenhurst, Hollywood, Calif.
Azure c/o Harold Plant, 449 S. Beverly Dr., Beverly Hills, Calif.
- BLB c/o Robert S. Taran 7920 East Dr., Miami Beach, Fla.
B. L. & H. 1650 Broadway, N.Y.C.
BNP c/o Four Star TV 4030 Radford Ave., N. H'wood, Cal.
B & R 17 West 71st St., N.Y.C.
B.R.B. c/o Sugarman 119 West 57th St., N.Y.C.
Bab c/o Joe Breeze 71 Grohman's La., Bethpage, N.Y.
Babell P.O. Box 375 Apple Valley, Calif.
Bae N.W. Cor. 8th & Fitzwater Sts., Phila., Pa.
Baer, Abel c/o Robbins-Feist-Miller 1540 Broadway, N.Y.C.
Baker, Murray 470 West End Ave., N.Y.C.
Baker 1270 Ave. of Americas, N.Y.C.
Bal 333 West 56th St., N.Y.C.
Bal Masque 30 Cabot Road W., Massapequa, N.Y.
Balladeer 1549 N. Vine St., H'wood, Cal.
Balladier 151 East 49th St., N.Y.C.
Ballard 900 Palmer Rd., Bronxville, N.Y.
Ballet Foundation, The 36 West 44th St., N.Y.C.
Ballet Russe De Monte Carlo 24 West 57th St., N.Y.C.
Balto 1650 Broadway, N.Y.C.
Baltor 745 S. Spaulding Ave., Los Angeles, Calif.
Banjee c/o Bob Banner Assoc., 545 Madison Ave., N.Y.C.
Bantam 15639 Woodfield Pl., Sherman Oaks, Cal.
Barbour-Lee 9157 Sunset Blvd., H'wood, Cal.
Barbrou 8008 Rodgers Rd., Elkins Park, Pa.
Barclay c/o Shapiro, Bernstein 666 Fifth Ave., N.Y.C.
Barcol 65 East 55th St., N.Y.C.
Bark 1650 Broadway, N.Y.C.
Barnaby 1500 N. Vine St., Hollywood, Calif.
Baron, M., P.O. Box 149, Oyster Bay, N.Y.
Barrister 79 West Monroe St., Chicago, Ill.
Barthel & Associates 166 W. Washington St., Chicago, Ill.
Barton 1619 Broadway, N.Y.C.
Basie, Diane 1631 Broadway, N.Y.C.
Bassman, George 292 Madison Ave., N.Y.C.
Bax 1630 N. Vine St., Hollywood, Calif.
Bayer 1650 Broadway, N.Y.C.
Bayshore 645 Larkin St., San Francisco, Calif.
Beachside 520 Fifth Ave., N.Y.C.
Beacon 441 West 49th St., N.Y.C.
Beatrice 360 N. Michigan Ave., Chicago, Ill.
Beaver 1650 Broadway, N.Y.C.
Bedack c/o Valando 22 West 48th St., N.Y.C.
Bedford 903 N. Bedford Dr., Beverly Hills, Cal.
Bee Cee P.O. Box 870, Hollywood, Calif.
Beekman 17 West 60th St., N.Y.C.
Bel-Air 608 Wlادن Dr., Beverly Hills, Cal.
Belan 4418 Spellman, Houston, Tex.
Bellino 3529 Big Dalton, Baldwin Park, Cal.
Bellmore c/o Herald Records, 150 West 55th St., N.Y.C.
Benco, see Arch
Bendoli 1153½ N. Edgemont Dr., Los Angeles, Calif.
Benello 1639 Broadway, N.Y.C.
Ben Gen 1595 Broadway, N.Y.C.
Ben-Tone 3042 Brighton 8th St., N.Y.C.
Benjamin, Bernie, 1619 Broadway, N.Y.C.
Benson, John T. 136 Fourth Avenue North, Nashville, Tenn.
Benton 896 Oneonta Dr., Los Angeles, Calif.
Bergman, Theodore 33 W. 48th St., N.Y.C.
Berklee 284 Newbury St., Boston, Mass.
Berlin, Irving 1290 Ave. of The Americas, N.Y.C.
Ber Mar 4801 Railroad Ave., E. Chicago, Ind.
Bernal 12126 Iredell St., Studio City, Cal.
Bernie, Dave 1423 North Fuller, H'wood, Cal.
Bernstein, M. 60 South Glencoe St., Denver, Colo.
Bet 1950 Tamarind, H'wood, Cal.
Beta 185 N. Wabash Ave., Chicago, Ill.
Bethany 3788 Paradise Rd., Las Vegas, Nev.
Beverly 2444 Wilshire Blvd., L.A., Calif.
Bibo 1619 Broadway, N.Y.C.
Big-B 1619 Broadway, N.Y.C.
Big Beat 22 Nelson Rd., Valley Stream, N.Y.
Big Four (4) 10740 Rancho St., Encino, Cal.
Big Island, 120 Riverside Dr., N.Y.C.
Billboard 200 West 57th St., N.Y.C.
Biltmore 345 West 58th St., N.Y.C.
Bing 35 West 53rd St., N.Y.C.
Birchard, C.C., 1834 Ridge Ave., Evanston, Ill.
Birdees 1501 Broadway, N.Y.C.
Bishop 5101 Matilija, Sherman Oaks, Cal.
- Bismark, 250 S. Broad St., Philadelphia, Pa.
Bizet 1733 B'way, N.Y.C.
Blackstone 1841 Broadway, N.Y.C.
Blen 11670 Sunset Blvd., Los Angeles, Calif.
Bloch 31 West 31st St., N.Y.C.
Bloom, Ben 1619 Broadway, N.Y.C.
Blossom 322 West 48th St., N.Y.C.
Bluebell 5659 Heiskell St., Phila., Pa.
Blue Hill 15 Rosemont Rd., Boston, Mass.
Blue Seas 166 E. 61st St., N.Y.C.
Blue Sky 7702 Hollywood Blvd., Hollywood, Calif.
Bobby Tunes 6277 Selma Ave., H'wood, Cal.
Bobcat 1650 Broadway, N.Y.C.
Boco 6319 Babcock Ave., N. H'wood, Cal.
Boda 1650 Broadway, N.Y.C.
Bond, Carrie Jacobs 116 Boylston St., Boston, Mass.
Bond Street 43 Bond St., Brooklyn, N.Y.
Bonfen 340 East 74th St., N.Y.C.
Bonnie 1631 Broadway, N.Y.C.
Bonny 733 3rd Ave., N.Y.C.
Bonnyville 7120 Sunset Blvd., H'wood, Cal.
Bonwit 990 Palm Ave., Los Angeles, Calif.
Boosey & Hawkes, 30 West 57th St., N.Y.C.
Boston 116 Boylston St., Boston, Mass.
Boulder 9 Rockefeller Plaza, N.Y.C.
Bourne 136 West 52nd St., N.Y.C.
Bourne-Rank 136 West 52nd St., N.Y.C.
Boutell 10540 Nat'l Blvd., L.A., Cal.
Box & Cox (Publications) 300 West 53rd St., Chicago, Ill.
Brazilliance P.O. Box 5265, Sherman Oaks, Calif.
Breen & De Rose 606 8th Ave., N.Y.C.
Breezy 1549 N. Vine St., Hollywood, Calif.
Bregman, Vocco & Conn 1619 Broadway, N.Y.C.
Breland 40 West 55th St., N.Y.C.
Bridgton 285 Riverside Dr., N.Y.C.
Briegel, George F. 17 West 60th St., N.Y.C.
Brigh 9547 Prospect Ave., Chicago, Ill.
Bright, Sol K. 1441 Kapiolani, Honolulu, Hawaii
Brighton 1780 Broadway, N.Y.C.
Brightwater 916 Kearney St., San Francisco, Calif.
Brisk 7634 Hampton Ave., Los Angeles, Calif.
Bristol 345 West 58th St., N.Y.C.
Broadway 135 West 50th St., N.Y.C.
Brockwin 200 West 57th St., N.Y.C.
Bromaur 6817 Tulip Hill Terrace, Wash., D.C.
Bronson, Sam 10 Columbus Circle, N.Y.C.
Brookhouse 15 West 46th St., N.Y.C.
Brooks 100 West 42nd St., N.Y.C.
Bro-Sil 959 Main, Buffalo, N.Y.
Broude Brothers 56 West 45th St., N.Y.C.
Brown, Marshall 315 West 53rd St., N.Y.C.
Brown, Robt. B., 1815 N. Kenmore Ave., Hollywood, Calif.
Buckeye 413 Race St., Cincinnati, Ohio
Buckingham 1674 Broadway, N.Y.C.
Budd 1619 Broadway, N.Y.C.
Buffington, Don 1203 West 6th St., Corona, Calif.
Bulls-Eye 6526 Selma Ave., H'wood, Cal.
Burdge & Company 5880 Hollywood Blvd., H'wood, Cal.
Burke, Joe 15 E. 48th St., N.Y.C.
Burke, Johnny, 250 W. 57, N.Y.C.
Burke & Van Heusen 250 W. 57, N.Y.C.
Burlington 539 West 25th St., N.Y.C.
Burnett, Ltd. 49 Franklin Ave., Saranac Lake, NY
Burning Bush 9100 Sunset Blvd., Hollywood, Calif.
Burthen 609 Fifth Ave., N.Y.C.
Bushkin, Joe 1740 Broadway, N.Y.C.
Butterfield 215 E. 68th St., N.Y.C.
Butterfly 1270 Sixth Ave., N.Y.C.
Buxton Hill 609 Fifth Ave., N.Y.C.
Byron Music 185 North Wabash Ave., Chicago, Ill.
- C.C. 309 S. Broad, Philadelphia, Pa.
"C.G." ("C.G." Music Div.) 9808 Wilshire Blvd., Beverly Hills, Cal.
C.M.A. c/o Alamo 1619 Broadway, N.Y.C.
C. R. 1841 Broadway, N.Y.C.
Cab 200 West 57th St., N.Y.C.
Caccamist Bros. 282 East Leroy St., L.A., Cal.
Cadence 119 West 57th St., N.Y.C.
Cadenza 1479 North Vine St., H'wood, Cal.
Caesar, Irving 1619 Broadway, N.Y.C.
Cahn Music 132 S. Rodeo Dr., Beverly Hills, Calif.
Cal 174 East 74th St., N.Y.C.
Calico Records (Calico Publishing Div.) 400 Bakewell Building, Pitts., Pa.
Callender, Red 6015 Sunset Blvd., H'wood, Calif.
Camelback Mountain 53 E. 54th St., N.Y.C.
Camelot 53 E. 54th St., N.Y.C.
Campbell-Connelly 565 Fifth Ave., N.Y.C.
Campbell, Lloyd 1806 Broadway, San Fran. Calif.
Candee 5205 Colerain Ave., Cincinnati, Ohio
Candell 84-20 51st Ave., Elmhurst, N.Y.
Candix (Sildix Music Div.) 6425 Hollywood Blvd., H'wood, Cal.
Capa 6740-42 South Clyde Ave., Chicago, Ill.
Cape 31 Linnet St., W. Roxbury, Mass.
Capital Press 556 Fifth Ave., N.Y.C.
Car-Mar 15417 Sutton St., Sherman Oaks, Cal.
Carbaugh 332 S. Michigan Ave., Chicago, Ill.
Carew, Roy J. 818 Quintana Place, NW Wash., D.C.
Carlred Radio Station WRVA, Richmond, Va.
Carlvi 511 S. Mariposa Ave., Los Angeles, Cal.
Carlyle c/o Larry Spier 1650 Broadway, N.Y.C.
Carmen 50 Broadway, N.Y.C.
Carmichael 119 West 57th St., N.Y.C.
Carol 1023 North La Brea, L.A., Cal.
Carrie 1841 Broadway, N.Y.C.
Carroll 11734 Wilshire Blvd., Los Angeles, Cal.
Carrol, David 79 W. Monroe, Chicago, Ill.
Carsan P.O. Box 19024, Houston, Texas
Case 1619 Broadway, N.Y.C.
Catawba 1619 Broadway, N.Y.C.
Cathryl 608 Fifth Ave., N.Y.C.
Cavalcade 136 East 57th St., N.Y.C.
Cecilia 63 Hamilton Terrace, N.Y.C.
Cee Bee 6636 Tujunga Ave., N. H'wood, Cal.
Cello 6650 Hollywood Blvd., H'wood, Cal.
Center 808 N. Broad, Phila., Pa.



THE VINCENT YOUMANS CO., INC.

Mode Music, Inc.

Scope Music, Inc.

Current New Releases

TAKE YOU FOR GRANTED? (No, Indeed!)

(Larry Alexander—Billy Goldenberg)

GEORGIA BROWN — CAPITOL

THE GIRL WITH THE HEATHER GREEN EYES

(Guy Wood — Mack Discant)

THE ARBORS — MERCURY

SHOULDN'T THERE BE LIGHTNING?

(Larry Alexander—Billy Goldenberg)

LIZA MINNELLI — CAPITOL

ROBERT LISSAUER

Vice President & General Manager

157 W. 57th Street

New York 10019

CI 5-2828

(Continued on next page)

ANYWHERE IN THE WORLD...

YOU'RE IN GOOD HANDS

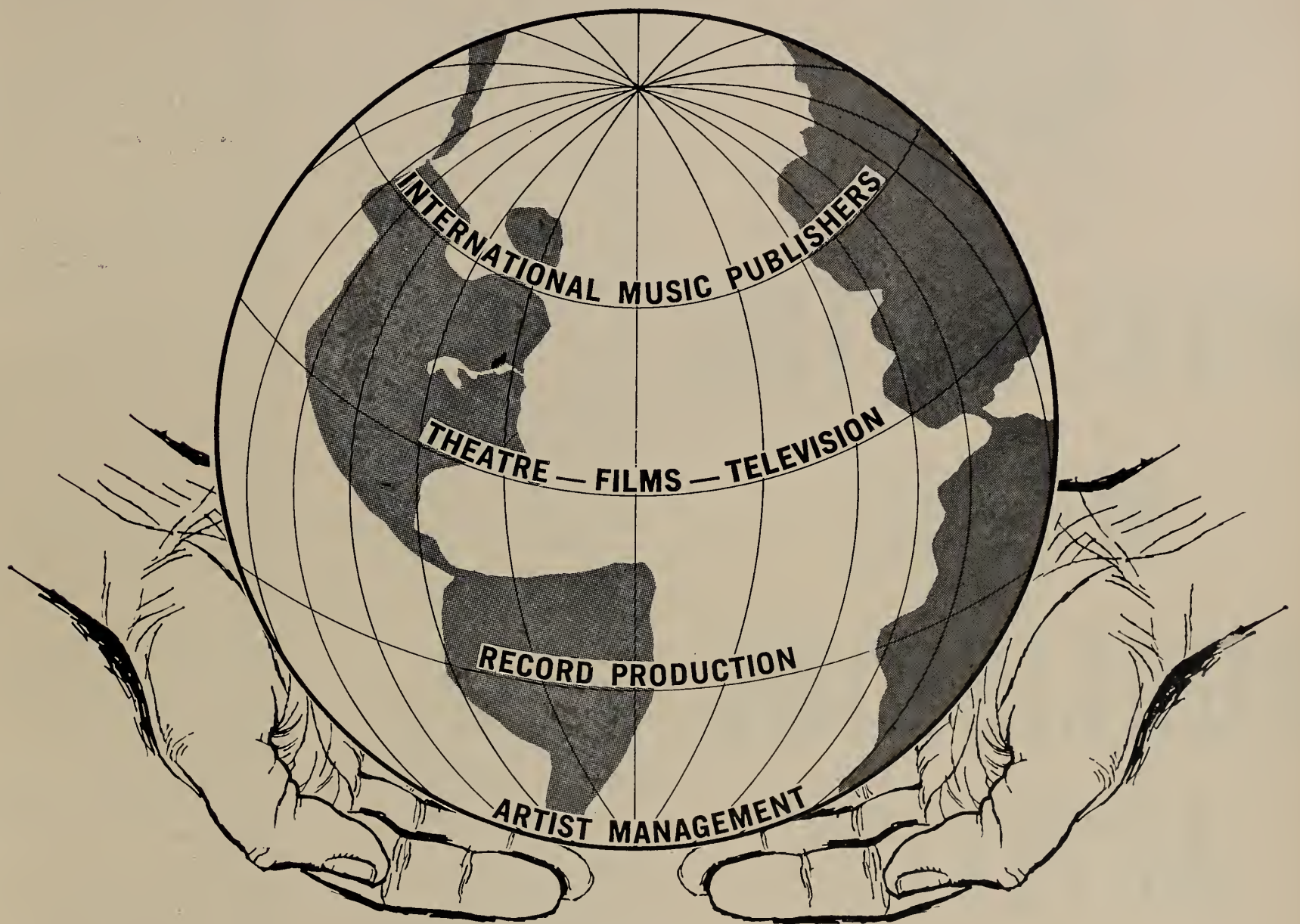

WHEN YOU'RE WITH...

A. SCHROEDER MUSIC CORPORATION



ABBY STEINBERG / WALLY GOLD / DAVID MOOK

January Music Corp./Sea-Lark Enterprises, Inc./Arch Music Co., Inc./Pitfield Music, Inc./A. Schroeder Music Publishing Co., Ltd.-England/A. Schroeder Music (Australia) Pty. Ltd.-Australia/A. Schroeder Musikverlag KG-Germany/A. Schroeder-Basart, NV-Holland/Fermata Do Brasil, Ltd.-South America/Catalogo A. Schroeder-Italy/Editions Musicales A. Schroeder-France/A. Schroeder Musikforlag-Scandinavia/A. Schroeder-Grever International S.A.-Mexico/A. Schroeder Music Limited-South Africa

New York: 25 W. 56th St./JU 2-8810—Los Angeles: 8293 Sunset Blvd./OL 4-4665

THE BIG 3



WORLD-WIDE MUSIC PUBLISHING ACTIVITY

*With Branch Offices, Affiliates
and Associates In Principal Cities*

NEW YORK • HOLLYWOOD

TORONTO • MEXICO CITY • FRANKFURT

RIO DE JANEIRO • LONDON • VIENNA

PARIS • AMSTERDAM • BUENOS AIRES

COLOGNE • BRUSSELS • MADRID • GENEVA

MILAN • STOCKHOLM • TOKYO • SYDNEY

ASCAP PUBLISHERS

Central Park 57 East 55th St., N.Y.C.
 Central Park South 1650 Broadway, N.Y.C.
 Cessna 5966 Lakeview, Detroit 13, Mich.
 Charbourne 156 E. Superior St., Chicago, Ill.
 Chadwick 6087 Sunset Blvd., H'wood, Cal.
 Chalet 1631 Broadway, NYC
 Chalen 200 East End Ave., N.Y.C.
 Chamber 168 West 48th St., N.Y.C.
 Champagne 2444 Wilshire Blvd., Santa Monica, Cal.
 Chancery 1841 Broadway, N.Y.C.
 Chandler 1043 N. Carol Dr., L.A., Cal.
 Channel 1926 N. St., Andrews Pl., H'wood, Calif.
 Chappell 609 Fifth Ave., N.Y.C.
 Chappell-Styne, 609 Fifth Ave., N.Y.C.
 Charjane Box 295, Miami Shores, Fla.
 Charling 31 West 54th St., N.Y.C.
 Charter House 6873 Yeager Pl., Hollywood, Calif.
 Chasbro 789 Ponce De Leon Ave., Atlanta, Ga.
 Chatham 1619 Broadway, N.Y.C.
 Chatsworth 1619 Broadway, N.Y.C.
 Ched 1650 Broadway, N.Y.C.
 Cherokee 18964 Pacific Coast Hwy, Malibu, Calif.
 Cherry Lane 142 E. 34th St., N.Y.C.
 Cherrypell 1615 Westwood Blvd., W. Los Angeles, Calif.
 Chesnick c/o Norman Rosemont, Plaza Hotel, N.Y.C.
 Chestnut 706 Chestnut St., St. Louis, Mo.
 Chilton 2233 Bellefontaine Blvd., Houston, Tex.
 Chippendale 6087 Sunset Blvd., H'wood, Cal.
 Chitquita 1619 Broadway, N.Y.C.
 Choice 9109 Sunset Blvd., H'wood, Cal.
 Choral 5103 Bellaire Ave., H'wood, Cal.
 Chordinators 850 7th Ave., N.Y.C.
 Christopher 14921 Tuba St., San Fernando, Cal.
 Cina-Star 2341 South 16th St., Phila., Pa.
 Cindy 157 West 57th St., N.Y.C.
 Citation 211 West 53rd St., N.Y.C.
 Claire 4331 Ithica St., Elmhurst, NY
 Clann 1650 Broadway, N.Y.C.
 Clara 120 West 57th St., N.Y.C.
 Claridge 250 West 57th St., N.Y.C.
 Clarion 421 Melrose St., Chicago, Ill.
 Claro 145-55 108th St., Springfield Gdns., NY
 Clearview 206 South 13th St., Phila., Pa.
 Clover 1619 Broadway, New York 19, NY
 Coca 19 West 44th St., N.Y.C.
 Codell 136 East 56th St., N.Y.C.
 Cohan, George M. 1776 Broadway, N.Y.C.
 Colby c/o S. J. Buzzell 460 Park Ave., N.Y.C.
 Coleman-Ross Company 550 Fifth Ave., N.Y.C.
 Col-Gems 711 5th Ave., N.Y.C.
 Collie 2054 Kenilworth Ave., L.A., Cal.
 Colombo, Franco 16 West 61st St., N.Y.C.
 Colonese 599 Walton Ave., N.Y.C.
 Colony 419 South 48th St., Phila., Pa.
 Colpix 711 Fifth Ave., N.Y.C.
 Columbia Pictures 666 Fifth Ave., N.Y.C.
 Comac 670 N. Michigan Ave., Chicago, Ill.
 Comet 250 W. 57, N.Y.C.
 Commander 1610 North Argyle, H'wood, Cal.
 Commercial 1619 Broadway, N.Y.C.
 Comparsa 756 7th Ave., N.Y.C.
 Composers (Div. of Contemporary Records) 8481 Melrose Pl., L.A., Cal.
 Composers Press 4941 Ambrose Ave., Los Angeles, Calif.
 Compton 1733 Broadway, N.Y.C.
 Comstock 711 5th Ave., N.Y.C.
 Concertone 161 West 54th St., N.Y.C.
 Congress 410 N.E. 17th St., Miami 32, Fla.
 Conley 250 West 57th St., N.Y.C.
 Connelley, Reg 1619 Broadway, N.Y.C.
 Conquest 135 West 50th St., N.Y.C.
 Consolidated 240 West 55th St., N.Y.C.
 Consonant 224 West 49th N.Y.C.
 Contemporary 488 Shurs Lane, Phila, Pa.
 Contree 1619 Broadway, N.Y.C.
 Cooper 309 West 57th St., N.Y.C.
 Copa 1650 Broadway, N.Y.C.
 Cornucopia 1270 Sixth Avenue, N.Y.C.
 Coronet 1650 Broadway, N.Y.C.
 Cosmic 171 Luring Dr., Palm Springs, Calif.
 Cosmopolitan 545 Fifth Ave., N.Y.C.
 Counselor 250 East 116th St., N.Y.C.
 Count Don 1674 Broadway, N.Y.C.
 Court c/o Fong & Tong Public Accounts, 916 Kearney St., San Francisco, Calif.
 Cover Records (Blanket Publishing Co. Div.) 1755 York Ave., Memphis, Tenn.
 Crazy 1270 Sixth Ave., N.Y.C.
 Crescendo 1619 Broadway, N.Y.C.
 Crescent 1650 Broadway, N.Y.C.
 Cressada 250 West 57th St., N.Y.C.
 Crestview 250 W. 57, N.Y.C.
 Crisscott 10807 Wellworth Ave., L.A. Cal.
 Criterion 150 West 55th St., N.Y.C.
 Gromwell 10 Columbus Circle, N.Y.C.
 Cross Keys 319 Seventh Avenue North, Nashville, Tenn.
 Crudwell 333 East 10th St., N.Y.C.
 Crystal Wilshire-Rexford Bldg., 9301 Wilshire Bldg., Beverly Hills, Calif.
 Culver 1432 N. Wilcox Ave., H'wood, Cal.
 Cunningham, Pail 60 Sutton Pl. South, N.Y.C.
 Curtain Call 518 5th Ave., N.Y.C.
 Curtis 25 Central Park W., N.Y.C.
 Cusenza, Frank J. Dada Bldg., 6525 Lincoln, Detroit, Mich.

Day 409 West 57th St., N.Y.C.
 Dayben 39 West 55th St., N.Y.C.
 Daymer 729 7th Ave., N.Y.C.
 Dayton 1800 N. Argyle Ave., Hollywood, Cal.
 Dean 4532 Ben Ave., N. H'wood, Cal.
 Deane, E. V. 4405 Macnish St., Elmhurst, N.J.
 Debbie Anne 4419 Wayne Ave., Philadelphia, Pa.
 Debbie-Jo 1608 North Argyle, H'wood, Cal.
 Debmarr 1320 Vine St., Phila., Pa.
 December c/o Ross Jungnickel 1619 Broadway, N.Y.C.
 Deekay 40 West 55th St., N.Y.C.
 Dee-Pam 4155 Mary Ellen Ave., H'wood, Cal.
 Deep River c/o Frank Sampson 155 E. 24th St., N.Y.C.
 Deerhaven 37 West 57th St., N.Y.C.
 Defranco, Joseph, Enterprises (Meloclass Music Div.) 10834 Haskell Ave., Granada Hills, Calif.
 DeLange 418 S. Roxbury Dr., Beverly Hills, Calif.
 Delaware 1674 Broadway, N.Y.C.
 Delkas Music c/o Leeds 322 West 48th St., N.Y.C.
 Delmore 550 Fifth Ave., N.Y.C.
 Delphine 157 West 57th St., N.Y.C.
 Del-Serbo 1211 Wharton St., Phila., Pa.
 Delta Research 855 Treat Ave., San Francisco, Calif.
 Dena 6758 Colgate Ave., L.A., Cal.
 Denny 146 Seventh Ave., N., Nashville, Tenn.
 Denper 119 W. 57th St., N.Y.C.
 Denric 9350 Wilshire Blvd., Beverly Hills, Calif.
 Denslow c/o Peggy Lee 2345 Kimridge Rd., Beverly Hills, Calif.
 Denton & Haskins 1650 Broadway, N.Y.C.
 Desilu 119 West 57th St., N.Y.C.
 Desmo 108 West 42nd St., N.Y.C.
 Desylva, Brown 609 Fifth Ave., N.Y.C.
 Deutsch, M.G. 110 Riverside Dr., N.Y.C.
 Devere 1483 N. Vine St., Hollywood, Calif.
 Dexter 387 6th St., San Francisco, Cal.
 Diana 619 Broadway, N.Y.C.
 Dickson 140 East 56th St., N.Y.C.
 Diana 120 E. 56th St., N.Y.C.
 Disal 119 West 57th St., N.Y.C.
 Discmakers 825 Madison Ave, N.Y.C.
 Disney, Walt 550 South Buena Vista, Burbank, Cal.
 Dolcedo 150 West 55th St., N.Y.C.
 Dolfi c/o Ross Jungnickel, 1619 Broadway, N.Y.C.
 Dolores 8115 Mulholland Terr., Los Angeles, Calif.
 Dominant 271 Central Park West, N.Y.C.
 Donald 200 West 57th St., N.Y.C.
 Donaldson 132 S. Rodeo Dr., Beverly Hills, Calif.
 Don-De 54 W. Randolph St., Chicago, Ill.
 Donde 1607 El Centro, H'wood, Cal.
 Don-Dor 785 West End Ave., N.Y.C.
 Dongon 157 West 57th St., N.Y.C.
 Dontone 461 Central Pk. W., N.Y.C.
 Dorabet 925 Wilshire Blvd., Beverly Hills, Calif.
 Dorchester 6058 Goodland Ave., N. H'wood, Calif.
 Dorella 609 Fifth Ave., N.Y.C.
 Dorothy 21843 Salmon Ave., Long Beach, Cal.
 Dorian 501 Madison Ave., N.Y.C.
 Doris 21 West Illinois St., Chicago, Ill.
 Doris Gee 515 Madison Ave., N.Y.C.
 Dornelle P.O. Box 68, Hollywood, Calif.
 Dorney Bros. 240 West 55th St., N.Y.C.
 Dorton 630 Fifth Ave., N.Y.C.
 Dottie 1225 6th Ave., N.Y.C.
 Double-A Ziegfeld Theater, N.Y.C.
 Douglas 609 Fifth Ave., N.Y.C.
 Douglas-Davilo 1619 Broadway, N.Y.C.
 Dov 445 Park Ave., N.Y.C.
 Dove 1674 Broadway, N.Y.C.
 Dovine, 1240 Northridge Rd., Columbus, Ohio
 Drake 2601 Henry Hudson Parkway, N.Y.C.
 Dralo 51 5th Ave., N.Y.C.
 Drexel Suite 420, Union Bank Bldg., Beverly Hills, Cal.
 Drysen 75 East 55th St., N.Y.C.
 Duane 2265 Fifth Ave., N.Y.C.
 Dubonnet 211 West 53rd St., N.Y.C.
 Dudley Manners 177 Beach 141st St., Bell Harbor, N.Y.
 Duet 350 West 57th St., N.Y.C.
 Dufferin 1650 Broadway, N.Y.C.
 Duncan, Jimmy (Shevrick Music Div.) 505 Melrose Bldg., Houston, Tex.
 Dunhill, 60 E. 42nd St., N.Y.C.
 Durante, Jimmy 6317 Yucca St., L.A., Cal.
 Dymor 717 5th, N.Y.C.
 Dwigar 119 W. 57th St., N.Y.C.
 Earl 111 E. 88th St., N.Y.C.
 East Hill 1003 Sunset-Vine Tower Bldg., L.A., Cal.
 East-West 1619 Broadway, N.Y.C.
 Ecaroh 400 Central Park West, N.Y.C.
 Ecco Box 1465, Beverly Hills, Cal.
 ECF 161 East Erie, Chicago, Ill.
 Ecton & Mosier 111 Broadway, Santa Monica, Calif.
 Eddie-O 8071 Selma Ave., Los Angeles, Calif.
 Edition Musicus-New York, 333 West 52nd St., N.Y.C.
 Editone 12316 Landale St., Studio City, Cal.
 Edition Omicron 475 5th Ave., N.Y.C.
 Edwards, H & S 15 E. 48th St., N.Y.C.
 Edwards 135 West 50th St., N.Y.C.
 Ego 46 Martin Dr., New Orleans, La.
 El Dorado 2990 West Pico Blvd., L.A. Cal.
 El-Jay 446 S. Maple Dr., Beverly Hills, Calif.
 El-Ray 1825 North Curson Ave., H'wood, Cal.
 Elar Music 609 Fifth Ave., N.Y.C.
 Electra 511 Fifth Ave., N.Y.C.
 Electro Sew Vax Service (E.S.V. Records Div.) 2308-B West 8th St., Cincinnati, Ohio.
 Elephant 161 W. 54th St., N.Y.C.
 Eleventh Avenue Theatricals 770 11th Ave., N.Y.C.
 Eleventh Floor 1619 Broadway, N.Y.C.
 Eliana 342 Madison Ave., N.Y.C.
 Elgin 12505 Ferris, Cleveland, O.
 Elkan, Henri 1316 Walnut St., Phila., Pa.
 Elkan-Vogel 1716 Sansom St., Phila., Pa.
 Ellipsis 1420 Walnut St., Philadelphia, Pa.
 Elm Drive 608 Fifth Ave., N.Y.C.
 Elmont 119 West 57th St., N.Y.C.
 Elmway 1270 6th Ave., N.Y.C.
 El Tee 6021 Sunset Blvd., Los Angeles, Calif.

(Continued on next page)

ASCAP

The Music of America



The American Society
of Composers, Authors and Publishers
has a membership of more than 10,000
men and women who create and publish
the music of our nation.

Our members are active
in every field of musical literature:
Broadway shows, motion pictures,
television, radio, religious, symphonic
and concert, country and folk music —
all these are included
in the ASCAP repertory.

The music which
ASCAP offers, through its
system of licensing, provides the one essential
vital to the entertainment and pleasure
of the public. In brief — ASCAP music
is the music of America.



The American Society of Composers, Authors and Publishers
575 Madison Avenue, New York, New York 10022

ASCAP PUBLISHERS

Emarcy 35 East Wacker Dr., Chicago, Ill.
 Emery 230 West 41st St., N.Y.C.
 Emes 621 North Alta Dr., Beverly Hills, Cal.
 Emily 160 West 73rd St., N.Y.C.
 Emjay 887 No. 66th St., Phila., Pa.
 Empire 227½ South Glenwood Pl., Burbank, Cal.
 Empress 119 West 57th St., N.Y.C.
 Em Ru 64 E. Van Buren, Chicago, Ill.
 Encore 4249 Bakman Ave., N. H'wood, Cal.
 Enlight 451 N. Canon Dr., Beverly Hills, Cal.
 Enterprise 11360 Dona Dorotea Dr., Studio City, Cal.
 Envoy 511 Fifth Ave., N.Y.C.
 Erica 35 West 53rd St., N.Y.C.
 Erosa 333 South Windsor Blvd., L.A., Cal.
 Essex 10 Columbus Circle, N.Y.C.
 Ecstasy 1697 Broadway, N.Y.C.
 Eta 1614 E. State St., Trenton, N.J.
 Etcetera 12315 Rye St., N. H'wood, Cal.
 Ethelbert 818 Kendall Dr., Nashville, Tenn.
 Etheleese 1595 Broadway, N.Y.C.
 Eurasia 816 Hyperion Ave., L.A., Cal.
 Evans, Redd 1619 Broadway, N.Y.C.
 Evergreen 10710 Henshaw St., Woodland Hills, Calif.
 Exeter 10 Columbus Circle, N.Y.C.
 Exotica 8721 Sunset Blvd, Los Angeles, Calif.

F & W 2534 West Pico Blvd., L.A., Cal.
 FTP 157 West 57th St., N.Y.C.
 Fabulous 1616 Argyle Ave., H'wood, Cal.
 Fain 1640 San Ysidro Dr., Beverly Hills, Cal.
 Fairbanks 250 West 57th St., N.Y.C.
 Fairlane 8625 Santa Monica Blvd., Los Angeles, Cal.
 Fairway 609 Fifth Ave., N.Y.C.
 Faith & Freedom 5901 Rose Ave., Long Beach, Cal.
 Fajob 1420 Walnut St., Philadelphia, Pa.
 Famous 1501 Broadway, N.Y.C.
 Fancy 31-50 140th St., Flushing, NY
 Fanfare 1337 North Orange Dr., H'wood, Cal.
 Fantasy 250 West 57th St., N.Y.C.
 Farel 1247 North Flores, L.A., Cal.
 Farmer 12178 Ventura Blvd, Studio City, Cal.
 Farrow 340 E. 52nd St., N.Y.C.
 Favorite 1631 Broadway, N.Y.C.
 Favorite 1674 Broadway, N.Y.C.
 Fay-Ro 118 E. 31st St., N.Y.C.
 Feist, Leo 1540 Broadway, N.Y.C.
 Features, 235 E. 45th St., N.Y.C.
 Fenner 1017 Westlake Ave., L.A., Cal.
 Fermata International 10 Columbus Circle, N.Y.C.
 Festival 1570 52nd St., N.Y.C.
 Fidelio 292 Madison Ave., N.Y.C.
 Fideree 119 West 57th St., N.Y.C.
 Fidel (FMI) 664 Hemlock St., N.Y.C.
 Fifth Avenue 7715 Sunset Blvd., Hollywood, Calif.
 Fillmore c/o Carl Fisher 56 Cooper Sq., N.Y.C.
 Fischer, J. & Bro. 119 West 40th St., N.Y.C.
 Fischer, Carl 56 Cooper Sq., N.Y.C.
 Fisher, Fred 1619 Broadway, N.Y.C.

Fitzsimmons Sunset Vine Tower Bldg., Hollywood, Calif.
 Flagstone 914B 12th St., Sacramento, Cal.
 Flamingo 1619 Broadway, N.Y.C.
 Flammer, Harold 251 West 19th St., N.Y.C.
 Flanka 119 West 57th St., N.Y.C.
 Fletcher, Tex 57 3rd Ave., N.Y.C.
 Flight 9028 Sunset Blvd., L.A., Cal.
 Flo 59 East 54th St., N.Y.C.
 Florrnce 609 Fifth Ave., N.Y.C.
 Flywheel 916 Kearny St., San Francisco, Cal.
 Foley, Charles 67 West 44th St., N.Y.C.
 Folklore 176 Federal St., Boston, Mass.
 Fontaine 445 Park Ave., N.Y.C.
 Ford P.O. Box 78, Radio City Sta., N.Y.C.
 Foremost 8983 Sunset Blvd, H'wood, Cal.
 Formosa 1650 B'way, N.Y.C.
 Forster 216 South Wabash Ave., Chicago, Ill.
 Fortuna 729 Seventh Ave., N.Y.C.
 Fortune 9028 Sunset Blvd., Hollywood, Calif.
 Foster P.O. Box 2632, Palm Springs, Cal.
 42 1619 Broadway, N.Y.C.
 Foundation 1631 Broadway, N.Y.C.
 Four Jays 9425 Sunset Blvd, Beverly Hills, Cal.
 Fox, Sam 11 West 60th St., N.Y.C.
 Frama 833 East 14th St., Denver, Colo.
 Francis 128 Central Park South, N.Y.C.
 Francon 161 West 54th St., N.Y.C.
 Frank 119 West 57th St., N.Y.C.
 Franklin 150 West 57th St., N.Y.C.
 Freberg 7781 Sunset Blvd, L.A., Cal.
 Fred 414 E. 52nd St., N.Y.C.
 French, Samuel 24 West 45th St., N.Y.C.
 Friedman, Max 1119 Melon St., Pitts., Pa.
 Funt, Allen A. 60 W. 55th St., N.Y.C.
 Fullarton 488 Madison Ave., N.Y.C.
 Funco 3456 Floyd Terrace, Los Angeles, Calif.
 Futura 6308 Sunset Blvd., Hollywood, Calif.

G & C 609 Fifth Ave., N.Y.C.
 Gayle, Tim 6376 Yucca St., Hollywood, Calif.
 G.I. 1674 Broadway, N.Y.C.
 GME 9134 Sunset Blvd, L.A., Cal.
 Galaxy 2121 Broadway, N.Y.C.
 Gallegos, 1616 Argyle, Hollywood, Cal.
 Galleon Press 94 Greenwich Ave., N.Y.C.
 Gallico, Al 1790 Broadway, N.Y.C.
 Galvo 6515 Sunset Blvd., H'wood, Cal.
 Gannon & Kent 9744 Wilshire Blvd., Beverly Hills, Cal.
 Gardner 164 Alex St., Bridgeport, Conn.
 Garrick 522 Levering Ave., W. L.A., Cal.
 Gate 117 West 48th St., N.Y.C.
 Gateway 140 West 57th St., N.Y.C.
 Gaumont 7830 Miami View Drive, North Bay Island Miami Beach, Fla.
 Gayle, Tim 1036 North Dearhorn, Chicago, Ill.
 Geopio 2939 Serantine St., New Orleans, La.
 Gem 1650 Broadway, N.Y.C.
 Gemini 2122 Massachusetts Ave., N.W. Wash., D.C.
 Gene and Mel 2307 Mack Ave., Detroit, Mich.
 General 53 East 54th St., N.Y.C.
 George 250 North Canon Dr., Beverly Hills, Cal.

Georgeoff, Evan 1650 Broadway, N.Y.C.
 Geril 101 West 55th St., N.Y.C.
 Gershwin 609 Fifth Ave., N.Y.C.
 Gibbs 250 North Canon Dr., Beverly Hills, Cal.
 Gibson 7946 South Constance Ave., Chicago, Ill.
 Gigi 2333 Marbury Rd., Pitts., Pa.
 Gilbert, Ray 7223 Selma Ave., H'wood, Cal.
 Gilead 1154 North Western Ave., H'wood, Cal.
 Gilstro 1776 Broadway, N.Y.C.
 Giovanni 157 West 57th St., N.Y.C.
 Glad-Hamp 1560 Broadway, N.Y.C.
 Gladiator 1650 Broadway, N.Y.C.
 Gladstone c/o Vee Jay 1449 South Michigan Ave., Chicago, Ill.
 Gladys 1619 Broadway, N.Y.C.
 Glamford 885 Westminster St., Providence, R.I.
 Glamorous 1619 Broadway, N.Y.C.
 Glaser, Sioma 143 West 49th St., N.Y.C.
 Glean 30 West 60th St., N.Y.C.
 Glenbrook 756 Seventh Ave., N.Y.C.
 Glenden c/o Capitol Hi Fi 1500 Broadway, N.Y.C.
 Gold, Jack 1650 Broadway, N.Y.C.
 Gold, Joe 1674 Broadway, N.Y.C.
 Golden Bell 545 Fifth Ave., N.Y.C.
 Goldmine c/o Nick Kenny, N.Y. Daily Mirror 235 East 45th St., N.Y.C.
 Gold Seal 1612 Empire Way, Seattle, Wash.
 Golden 6758 Colgate Ave., L.A., Cal.
 Goldsen, Michael H. 150 West 55th St., N.Y.C.
 Goldwyn, Samuel 609 Fifth Ave., N.Y.C.
 Goman 1650 Broadway, N.Y.C.
 Good Foot 2934 Grand Route St. John, New Orleans, La.
 Goodman 825 West End Ave., N.Y.C.
 Good-Will 1619 Broadway, N.Y.C.
 Gordelys 15 Abingdon Sq., N.Y.C.
 Gordon-Murray 60 West 68th St., N.Y.C.
 Gould, Edward E. 3655 Berryman Ave., L.A., Cal.
 Grace 2225 West Olive Ave., Burbank, Cal.
 Gradick 1650 Broadway, N.Y.C.
 Grady 6535 Wilshire Blvd., L.A., Cal.
 Graham 1270 Sixth Ave., N.Y.C.
 Graham, Roger 7050 East End Ave., Chicago, Ill.
 Granadeane 381 West 78th St., N.Y.C.
 Grand 1619 Broadway, N.Y.C.
 Grandview 14418 Osborne St., Van Nuys, Cal.
 Granite 150 West 55th St., N.Y.C.
 Gray, H.W. 159 East 48th St., N.Y.C.
 Greene Walter 6119 Lexington Ave., L.A., Cal.
 Greenhaven 100 West 42nd St., N.Y.C.
 Greenlake 109 South Flores St., L.A., Cal.
 Greenwich 8300 Santa Monica Blvd., H'wood, Cal.
 Green Wind c/o Blue Breeze 15 East 48th St., N.Y.C.
 Gregory 1841 Broadway, N.Y.C.
 Grosvenor 4315 Evanston Ave., Seattle, Wash.
 Grosvenor House El Centro, H'wood, Cal.
 Guarnieri 54 Hillside Ave., Glen Ridge, N.J.
 Guild 25 Central Park West, N.Y.C.
 Guild Publications of California 3921 Fredonia Dr., H'wood, Cal.

Gunston 400 Madison Ave., N.Y.C.
 H-Q 608 Fifth Ave., N.Y.C.
 H.R. 8425 Melrose Ave., H'wood, Cal.
 H R H TV Features 444 Madison Ave., N.Y.C.
 Hal'LeLu'Jah 736 East 105th St., Cleve., Ohio
 Hallmark 626 North Rodeo Dr., Beverly Hills, Cal.
 Halsey 1674 Broadway, N.Y.C.
 Hamar 199 Wilson St., Hackensack, N.J.
 Hamilton 1619 Broadway, N.Y.C.
 Hamlet 1608 Argyle Ave., H'wood, Cal.
 Hampshire House 10 Columbus Circle, N.Y.C.
 Handman 56 West 45th St., N.Y.C.
 Handy Bros. 1650 Broadway, N.Y.C.
 Hanover 11825 Dorothy St., L.A., Cal.
 Hansen, Charles H. 119 West 57th St., N.Y.C.
 Hap Music 200 West 57th St., N.Y.C.
 Happiness 9428 Manor Rd., Kansas City, Mo.
 Harbet 40 East 49th St., N.Y.C.
 Harding 1674 Broadway, N.Y.C.
 Hargail 157 West 57th St., N.Y.C.
 Harlene 7165 West Sunset Blvd, H'wood, Cal.
 Harman 1619 Broadway, N.Y.C.
 Harmon, Larry 649 North Bronson Ave., H'wood, Cal.
 Harmony House of San Francisco P.O. Box 339, Mill Valley, Cal.
 Harmony 270 Madison Ave., N.Y.C.
 Harms, T.B. 609 Fifth Ave., N.Y.C.
 Harms 488 Madison Ave., N.Y.C.
 Haro 271 W. 125th St., N.Y.C.
 Harriet 608 Fifth Ave., N.Y.C.
 Harris, Chas. K. 1619 Broadway, N.Y.C.
 Harris, Harry 3231 Purdue Ave., L.A., Cal.
 Harrison 6300 Orion Ave., Van Nuys, Cal.
 Harvest 554 Fifth Ave., N.Y.C.
 Harwin 31 West 54th St., N.Y.C.
 Haven House 1560 North Laurel Ave., H'wood, Cal.
 Havenford 1619 Broadway, N.Y.C.
 Hawaiian P.O. Box 2061, Honolulu, Hawaii
 Haworth 35 Burlington Rd., Tenafly, N.J.
 Hayton-Horne 1619 Broadway, N.Y.C.
 Heartbeat 410 South Michigan Ave., Chicago, Ill.
 Hecht & Buzzell 119 West 57th St., N.Y.C.
 Hefti, Neal P.O. Box 571, Encino, Cal.
 Helayne 295 Central Park West, N.Y.C.
 Helena 520 Riverside Dr., N.Y.C.
 Hendricks 120 East 56th St., N.Y.C.
 Henita Music 4319 Clark Ave., P.O. Box 56, San Antonio, Tex.
 Henmar Press 373 4th Ave., N.Y.C.
 Hensley 54 Second Ave., N.Y.C.
 Herbec 9118 Sunset Blvd., L.A., Cal.
 Herbert 51 Chambers St., N.Y.C.
 Herman 3561 Valley Meadow Rd., Sherman Oaks, Cal.
 Hillcrest 575 Lexington Ave., N.Y.C.
 Hilliard, Boh 360 Allaire Ave., Leonia, N.J.
 Hillhorc c/o Adonis Records 200 West 56th St., N.Y.C.

*All Over the
 Charts
 All Over the
 World*

ARC REGENT JEWEL
 MUSIC CORP. MUSIC CORPORATION MUSIC PUBLISHING CO., INC.

1619 BROADWAY NEW YORK, N.Y. 10019 PHONE: (212) CIRCLE 6-1990 CABLE ADDRESS: "REGENTMUS"

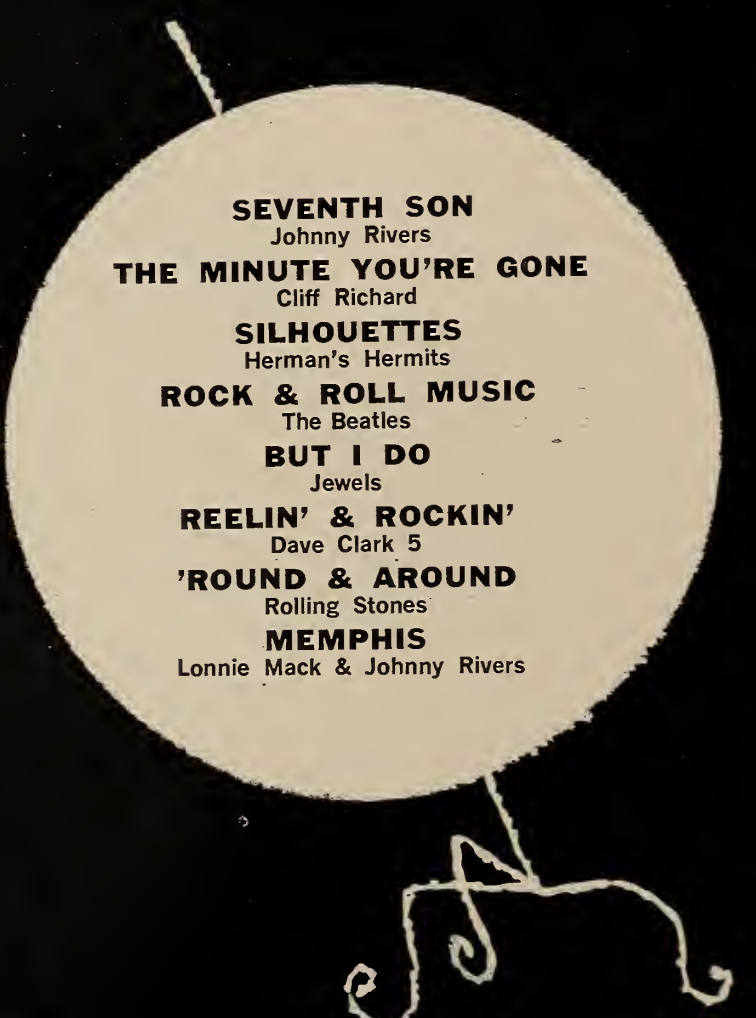

SEVENTH SON
 Johnny Rivers
THE MINUTE YOU'RE GONE
 Cliff Richard
SILHOUETTES
 Herman's Hermits
ROCK & ROLL MUSIC
 The Beatles
BUT I DO
 Jewels
REELIN' & ROCKIN'
 Dave Clark 5
'ROUND & AROUND
 Rolling Stones
MEMPHIS
 Lonnie Mack & Johnny Rivers

WEB IV

MUSIC INCORPORATED

WEAVING
IT'S
SPELL
AROUND THE WORLD

IV



PRODUCTIONS
(ARTISTS)

DRIFTERS
BEN E. KING
SOLOMON BURKE
EXCITERS
STRANGELOVES
BARBARA LEWIS
THEM
LOSERS
THE WITCHES
THE BEACH-NUTS
LAVERNE BAKER
ISLEY BROTHERS
THE McCOYS



**INTERNATIONAL
PUBLISHING
AFFILIATES**

S.A. ARMORE AND
BEECHWOOD LTD
72 QUAI DES
CHARBONNAGER
BRUSSELS, BELGIUM
(Belgium, Netherlands,
Luxembourg)

EDITION ACCORD
VERLAG UND VERTIEB FUR
INTERNATIONALS
MUSIK G.M.B.H.
KAMESKESTRA BE 31-33
(Germany, Switzerland,
Austria)

AGENCE MUSICALE
INTERNATIONALE
67 RUE DE PROVENCE
PARIS, FRANCE
(France, French Community,
Andora, Monaco)

EDITION ODEON
P.O. BOX 27053
STOCKHOLM 27 SWEDEN
(Sweden, Norway, Denmark,
Iceland, Finland)



WRITERS:
BERT RUSSELL
TWIST AND SHOUT
CRY BABY
TELL HIM
KILLER JOE
HERE COMES THE NIGHT
SLOOPY
CRY TO ME
LITTLE BIT OF SOAP
I WANT CANDY



RECORD COMPANIES ABROAD

ENGLAND—EMI
AUSTRALIA—EMI

WEB IV

MUSIC INCORPORATED 1650 BROADWAY, NEW YORK, N.Y. 10019 581-3740-1

ASCAP PUBLISHERS

Hillbrow c/o Benjamin Starr 161 West 54th St., N.Y.C.
 Hilltop 59 East 54th St., N.Y.C.
 Hillwood 2990 West Pico Blvd., L.A., Cal.
 Hintz 1674 B'way, N.Y.C.
 Hi-Point 3914 Hamilton Dr., Fort Worth, Tex.
 Hirt 165 East 66th St., N.Y.C.
 Hi-Ti 5326 Encino Ave., Encino, Cal.
 Hit 7533 Hollywood Blvd., H'wood, Cal.
 Hobby 80-15 Grenfell St., Kew Gardens, N.Y.
 Hodon 1619 Broadway, N.Y.C.
 Hoffman, Al 292 Madison Ave., N.Y.C.
 Holford 120-20 Hoffman St., Studio City, Cal.
 Hollybrook 485 Madison Ave., N.Y.C.
 Holly Hill 1744 N. Doreny Dr., L.A., Cal.
 Holly 836 West 57th Terrace Kansas City, Mo.
 Hollyjo 1650 Broadway, N.Y.C.
 Holly-Pix 4931 Alceve Ave., N. H'wood, Cal.
 Hometown 37-11 87th St., Jackson Hts., N.Y.
 Homeyer, Chas. W. 498 Boylston St., Boston, Mass.
 Honeycomb 324 South Beverly Dr., Beverly Hills, Cal.
 Hope 5707 West Lake St., Chicago, Ill.
 Hopkins 520 North Michigan Ave., Chicago, Ill.
 Horizon 6758 Colgate Ave., L.A., Cal.
 Horn, Paul c/o Jimmy McHugh 6381 Hollywood Blvd., H'wood, Cal.
 Horatio c/o Manhattan 1650 Broadway, N.Y.C.
 Horsley P.O. Box 58, Ottawa, Ontario, Canada
 House of Zog 116 South Fourth St., Las Vegas, Nevada
 Horton, Vaughn 1619 Broadway, N.Y.C.
 House of James 14739 Huston St., Sherman Oaks, Cal.
 House of Music Masters 29 Pine St., Chelsea, Mass.
 House of Nacio Herb Brown 10401 Wilshire Blvd., L.A., Cal.
 Howard, Beatrice, Hotel Alvin, Broadway & 52nd St., N.Y.C.
 Howard, Joe 5950 N. E. 22nd Ave., Fort Lauderdale, Fla.
 Howe-Lee 511 Fifth Ave., N.Y.C.
 Hub 9744 Wilshire Blvd., Beverly Hills, Cal.
 Hubert 322 West 48th St., N.Y.C.
 Hudson 205 East 42nd St., N.Y.C.
 Hummable 210 East 58th St., N.Y.C.
 Humphries, Bruce 48 Melrose St., Boston, Mass.
 Huntzinger, R. L. 124 East 4th St., Cincinnati, Ohio
 H.W.S. 1608 N. Argyle Ave., Hollywood, Cal.

Intercontinental Artist 730 Fifth Ave., N.Y.C.
 Interlude 6340 Hollywood Blvd., L.A., Cal.
 International Artists 604 Taft Blvd., H'wood, Cal.
 International Korwin 57 West 56th St., N.Y.C.
 International 509 Fifth Ave., N.Y.C.
 International 745 Fifth Ave., N.Y.C.
 International Pauline 57 West 56th St., N.Y.C.
 Intimate 1631 B'way, N.Y.C.
 Isabel 659 10th Ave., N.Y.C.
 Italamerica 322 97th St., Bklyn, N.Y.
 Invalee 6311 Yucca St., Hollywood
 Ivanhoe 415 East 52nd St., N.Y.C.
 Ivy Music 609 Fifth Ave., N.Y.C.

J-B 461 Dean St., Bklyn, N.Y.
 J & E 15 West 55th St., N.Y.C.
 J.P. 1619 Broadway, N.Y.C.
 JPB 1841 B'way, N.Y.C.
 J.V.P. 1060 Crenshaw Blvd., L.A., Cal.
 Jack-Do 1776 Broadway, N.Y.C.
 Jack Sky 7807 Farnsworth St., Phila., Pa.
 Jacobs, Walter 1540 Broadway, N.Y.C.
 Jacqueline c/o Shapiro, Bernstein 666 Fifth Ave., N.Y.C.
 Jad 411 Dubois Ave., Dallas, Tex.
 Jade 250 Wortman Ave., Bklyn, N.Y.
 Jameco 870-A South Broadway, Hicksville N.Y.
 James, Billy 4 Furness Lane, Wallingford, Chester County, Pa.
 James 1650 Broadway, N.Y.C.
 Jana 1247 Stoner Ave., L.A., Cal.
 Jandon 161 Cornell Ave., Valley Stream, N.Y.
 Jandor 100 Park Ave., N.Y.C.
 Janfra 756 Seventh Ave., N.Y.C.
 Janfred Hotel Chelsea, 222 West 23rd St., N.Y.C.
 Jan-Lee 260 El Camino Dr., Beverly Hills, Cal.
 Janmur 1740 Broadway, N.Y.C.
 Janon 8 East 48th St., N.Y.C.
 Jarrard 145 West 71st St., N.Y.C.
 Jay 12236 Hesby St., N. H'wood, Cal.
 Jaybar 1501 Broadway, N.Y.C.
 Jay-Bee 114 South Ocean Ave., Atlantic City, N.J.
 Jay IV 39 Andover Rd., Roslyn Hts., N.J.
 Jay-Kay 1270 Sixth Ave., N.Y.C.
 Jaymar 200 West 57th St., N.Y.C.
 Jaytone 13500 Crewe St., Van Nuys, Cal.
 Jayvee 31 West 54th St., N.Y.C.
 Jeannie 1129 East 15th St., Tulsa, Okla.
 Jed Music 517 N. Main St., Sidney, Ohio
 Jefferson 1619 Broadway, N.Y.C.
 Jeffrey 756 Seventh Ave., N.Y.C.
 Jen D. 540 East Walnut Lane, Phila., Pa.
 Jenkins 1217-23 Walnut St., Kansas City, Mo.
 Jenkins, Gordon 449 South Beverly Dr., Beverly Hills, Cal.
 Jennings 4130 Main St., Kansas City, Mo.
 Jericho 34 West 53rd St., N.Y.C.
 Jerry 706 Union Ave., Memphis, Tenn.
 Jewel 1619 Broadway, N.Y.C.
 Jildana 27 Stegman Pl., Jersey City, N.J.

Jim Jon 1622 South 9th St., Phila., Pa.
 JKLM 411 W. End Ave., N.Y.C.
 JimTim 1520 N. Board St., Phila., Pa.
 Jo-Al 1619 Broadway, N.Y.C.
 Jo-Art 525 Lexington Ave., N.Y.C.
 Jodi 632 Winchester Ave., Union, N.J.
 Joneil 1619 Broadway, N.Y.C.
 John Paul 2451 Nichols Canyon Rd., H'wood, Cal.
 Johnson, Jerry R. D. 1, Lebanon, N.J.
 Jo-Jon 1774 North Labrea, H'wood, Cal.
 Joleron 1270 Sixth Ave., N.Y.C.
 Joline c/o Jimmy McHugh 6381 Hollywood Blvd., H'wood, Cal.
 Joli Tinker 1619 Broadway, N.Y.C.
 Jolly 350 Fifth Ave., N.Y.C.
 Jolly 3126A Easton Ave., St. Louis, Mo.
 Jonathan 57 West 56th St., N.Y.C.
 Jones, Isham 1619 Broadway, N.Y.C.
 Jon-Tees 1614 Virginia Rd., L.A., Cal.
 Jopell 6944 Murietta Ave., Van Nuys, Cal.
 Josie 315 West 47th St., N.Y.C.
 Joy 1619 Broadway, N.Y.C.
 Juba Box 4313, Inglewood, Cal.
 Jubilee 609 Fifth Ave., N.Y.C.
 Judy 185 North Wabash, Chicago, Ill.
 Juke Box Alley c/o Tin Pan Alley Records 1650 Broadway, N.Y.C.
 Jui 3300 Lake Shore Dr., Chicago, Ill.
 Jungnickel, Ross 1619 Broadway, N.Y.C.

K & L 1507 North Vine St., H'wood, Cal.
 Kady 12143 Buckeye, San Fernando, Cal.
 Kahal, Irving 1740 Broadway, N.Y.C.
 Kahn, Gus 6223 Selma Ave., H'wood, Cal.
 Kalakaua P.O. Box 2457, Honolulu, Hawaii
 Kali 150 West 55th St., N.Y.C.
 Kali Yuga Box 305, Garden City, Cal.
 Kalman, Charles Emmerich 1619 Broadway, N.Y.C.
 Kalmann Music 1435 North 75th St., Phila., Pa.
 Kalmus, Edwin F. 154 West 57th St., N.Y.C.
 Kandy 203 Wabash North, Chicago, Ill.
 Kanes 80 Riverside Dr., N.Y.C.
 Karen 102-25 67th Dr., 1 G, Forest Hills, N.Y.
 Karin 7250 Beverly Blvd., L.A., Cal.
 Karolyn 1650 Broadway, N.Y.C.
 Kaseel Airs 6934 Firmament Ave., Van Nuys, Cal.
 Kassner, Edward 756 Seventh Ave., N.Y.C.
 Katikris P.O. Box 834, Greenwood Lake, N.Y.
 Kay, Edward 9250 Wilshire Blvd., Beverly Hills, Cal.
 Kean, Michael 50 Ridge Rd., Yonkers, N.Y.
 Keene 146 East 57th St., N.Y.C.
 Kellem, Milton 1619 Broadway, N.Y.C.
 Kelton 68 Mechanic St., New Rochelle, N.Y.
 Kendis 170-32 Cedarcroft Rd., Jamaica, N.Y.
 Kennor 4411 Sancelo Ave., N. H'wood, Cal.
 Kenam 7301-05 Harding Ave. Miami Beach, Fla.
 Kenyon 2 West 46th St., N.Y.C.
 Kenyon 1841 Broadway, N.Y.C.
 Keyboard 9350 Wilshire Blvd., Beverly Hills, Cal.

Keynote 1619 North Cherokee Ave., H'wood, Cal.
 Keystone 9615 Helen Ave., Sunland, Cal.
 Kimberly 211 West 58th St., N.Y.C.
 King Brand 1595 Broadway, N.Y.C.
 Kingsley 1619 Broadway, N.Y.C.
 Kingsway c/o Ross Jungnickel 1619 Broadway, N.Y.C.
 Kips Bay 108 W. 57th St., N.Y.C.
 Kiss 4669 Arriba Dr., Tarzana, Cal.
 Knickerbocker 1619 Broadway, N.Y.C.
 Knollwood 1619 Broadway, N.Y.C.
 Koff 1418 Bentley Ave., L.A., Cal.
 Kohn 1650 Broadway, N.Y.C.
 Koko 445 North Rossmore Ave., H'wood, Cal.
 Krader 143 Douglas Ave., Yonkers, N.Y.
 Kramer, Fred 1650 Broadway, N.Y.C.
 Kramer-Whitney 1650 Broadway, N.Y.C.
 Krashow 435 1/2 S. Oakhurst Dr., H'wood, Cal.
 Krasnor-Share 1700 Broadway, N.Y.C.
 Kuklapolitan 1335 Astor St., Chicago, Ill.
 Kulma 1619 Broadway, N.Y.C.

La Salle 1619 Broadway, N.Y.C.
 Lady Mac 136 West 52nd St., N.Y.C.
 Laerteas Box 265, Radio City Sta., N.Y.C.
 Lake Shore 612 North Michigan Ave., Chicago, Ill.
 Lamas c/o RKO Records 17 East 45th St., N.Y.C.
 Lambert P.O. Box 1071, GPD, N.Y.C.
 Landers 8303 Melrose Ave., L.A., Cal.
 Landgold 6515 Sunset Blvd., H'wood, Cal.
 Lane 2249 North Franklin St., Phila., Pa.
 Lange, John 6526 Selma Ave., H'wood, Cal.
 Lansdowne 1549 North Vine St., H'wood, Cal.
 Lansing 630 Fifth Ave., N.Y.C.
 Lantern 499 North Canon Dr., Beverly Hills, Cal.
 Lantz c/o General Music Corp. 1041 North Formosa Ave., H'wood, Cal.
 Laren c/o Ross Jungnickel 1619 Broadway, N.Y.C.
 Largo 1608 North Argyle Ave., H'wood, Cal.
 Larilee 5642 Beck Ave., N. Hollywood, Calif.
 Lassie 270 No. Cannon Dr., H'wood, Cal.
 Laurel 22 West 48th St., N.Y.C.
 Lavere 247 Fort Pitt Blvd., Pitts., Pa.
 Lawson-Gould 609 Fifth Ave., N.Y.C.
 Leajay 5056 Marine Dr., Chicago, Ill.
 Lear 1270 Sixth Ave., N.Y.C.
 Lednam 120 West 57th St., N.Y.C.
 Lee 165 West 46th St., N.Y.C.
 Leann 782 Eighth Ave., N.Y.C.
 Leeds 322 West 48th St., N.Y.C.
 Leevan 1650 Broadway, N.Y.C.
 Leeway 4042 Benedict Canyon, Sherman Oaks, Cal.
 Leftwich 659 South Orange Dr., L.A., Cal.
 Legend 210 Central Park South, N.Y.C.
 Lejo 33 Riverside Dr., N.Y.C.
 Le-Mor 823 South Wabash Ave., Chicago, Ill.
 Lenore 112 West Randolph St., Chicago, Ill.

(Continued on next page)

Thank you
Burt Bacharach and Hal David



Congratulations

TOM JONES

"Most Promising Male Vocalist" (1st)

Cash Box D.J. Poll

Current Single

WHAT'S NEW PUSSYCAT ?

9765



A DIVISION OF
LONDON RECORDS, INC



Congratulations

MARIANNE FAITHFULL

"Most Promising Female Vocalist" (2nd)

Cash Box D.J. Poll

Current Single

SUMMER NIGHTS

9780



RECORDS



Congratulations

WILLIE MITCHELL

"Most Promising Instrumentalist" (3rd)

Cash Box D.J. Poll

Current Single

BUSTER BROWNE

2091



THE AMERICAN LONDON GROUP

ASCAP PUBLISHERS

- Leonia 1619 Broadway, N.Y.C.
Lerner, Samuel 1857 N. Wilton Pl., H'wood, Cal.
Lerner 250 North Canon Dr., Beverly Hills, Cal.
Loo's 1797 Sumter St., N.W., Atlanta, Ga.
Leopold 102 North Westgate, L.A., Cal.
Lero 2990 West Pico Blvd., L.A., Cal.
Leslie, Edgar 59 West 46th St., N.Y.C.
Leslie Prod. 57 West 58th St., N.Y.C.
Leslie Music 1010 South Robertson Blvd., L.A., Cal.
Levine-McHugh Time & Life Bldg., N.Y.C.
Levine-McHugh 6381 Hollywood Blvd., H'wood, Cal.
Lewki 210 E. 53rd St., N.Y.C.
Lew-Lou 17137 Otsego St., Encino, Cal.
Lewis 39 West 60th St., N.Y.C.
Lexington 670 North Michigan Ave., Chicago, Ill.
Libby 1700 North Gardner St., H'wood, Cal.
Liberty 6920 Sunset Blvd., H'wood, Cal.
Like Young 4610 Kester Ave., Sherman Oaks, Calif.
Lilli 3 Sheridan Sq., N.Y.C.
Lin 1502 136th Ave., San Leandro, Cal.
Linalan 618 South Glenwood Pl., Burbank, Cal.
Lincoln 160 Central Park South, N.Y.C.
Lindabet 34 West 53rd St., N.Y.C.
Lindley 360 North Camden Dr., Beverly Hills, Cal.
Lion 1540 Broadway, N.Y.C.
Lionel 1 Hanson Pl., Bklyn, N.Y.
Lisa-Ann 157 West 57th St., N.Y.C.
Lisalee 21 West 55th St., N.Y.C.
Lite 136 East 55th St., N.Y.C.
Littlefield 3563 Jasmine Ave., L.A., Cal.
Livingstone and Evans 1 East 57th St., N.Y.C.
Liza 1700 Broadway, N.Y.C.
Lloyd's of Hollywood Box 407, H'wood, Cal.
Loma Vista 8330 West 3rd St., L.A., Cal.
Lombard 7953 Hollywood Blvd., H'wood, Cal.
Lombardo 1619 Broadway, N.Y.C.
Londontown 6758 Colgate Ave., L.A., Cal.
Long 6087 Sunset Blvd., H'wood, Cal.
Longridge 6087 Sunset Blvd., H'wood, Cal.
Longview 6087 Sunset Blvd., H'wood, Cal.
Loop 5065 Gaviota Ave., Encino, Cal.
Lopez, V., 769 Seventh Ave., N.Y.C.
Lord 475 Fifth Ave., N.Y.C.
Lorenz 501 East 3rd St., Dayton, Ohio
Lorin, Will 326 East 43rd St., N.Y.C.
Lotta 1650 Broadway, N.Y.C.
Louwin "I" and Schiller Sts., Phila., Pa.
Love (Love Div.) 56 3rd St., Hoboken, N.J.
Lowe 1405 Locust St., Phila., Pa.
Lowner, Eric c/o Candy Records 777 Connecticut Blvd., East Hartford, Conn.
Lugar 475 Fifth Ave., N.Y.C.
Lu-Jac 609 Fifth Ave., N.Y.C.
Lu-Mel 124 West 79th St., N.Y.C.
Luristan 723 Seventh Ave., N.Y.C.
Luxecraft 2358 Fourth St., Bklyn, N.Y.
Lyle c/o Associates Recording 723 Seventh Ave., N.Y.C.
Lynjen 1619 Broadway, N.Y.C.
Lynn 2805 65th St., Woodside, N.Y.
Lynnstorm 451 North Canon Dr., Beverly Hills, Cal.
Lyric 120 Schermerhorn St., Bklyn, N.Y.
Lyrical Miracles 226 South Beverly Dr., Beverly Hills, Cal.
M.K.T. 9110 Sunset Blvd., L.A., Cal.
M.L. 1631 Broadway, N.Y.C.
M.S.I. 8848 Sunset Blvd., H'wood, Cal.
M.S.K. 1564 Broadway, N.Y.C.
M.Z.G. 8315 Clinton, L.A., Calif.
Mabreeze 520 Fifth Ave., N.Y.C.
Mabs 8831 Sunset Blvd., L.A., Cal.
Macap 222 West 83rd St., N.Y.C.
Madrigal 9250 Wilshire Blvd., Beverly Hills, Cal.
Magidson 10464 Lindbrook Dr., L.A., Cal.
Magnificent 527 Madison Ave., N.Y.C.
Majestic 1240 Park Ave., N.Y.C.
Makeba 270 Madison Ave., N.Y.C.
George Paxton 1619 Broadway, N.Y.C.
Malloy 6425 Hollywood Blvd., H'wood, Cal.
Maltby, Richard Cold Spring Rd., Syosset, N.Y.
Malverne 4 Azalea Dr., Syosset, N.Y.
Manchester 10 Columbus Circle, N.Y.C.
Manhattan 1650 Broadway, N.Y.C.
Mann, Herbie 72-79 Yellowstone Blvd., Forest Hills, N.Y.
Manning 1229 North Olive Dr., L.A., Cal.
Manseau 226 North Canon Dr., Beverly Hills, Cal.
Mansfield 488 Madison Ave., N.Y.C.
Mansion 136 West 52nd St., N.Y.C.
Mantovani c/o Ross Jungnickel, Inc. 1619 Broadway, N.Y.C.
Mappa 6087 Sunset Blvd., H'wood, Cal.
Mara 8745 Sunset Blvd., L.A., Cal.
Maral 6757 Hollywood Blvd., H'wood, Cal.
Mara-Lane 609 Fifth Ave., N.Y.C.
Maraville 1619 Broadway, N.Y.C.
Mardel 200 West 57th St., N.Y.C.
Margery c/o Flanka 119 West 57th St., N.Y.C.
Margin 6724 Allott Ave., Van Nuys, Cal.
Marguerita c/o Larry Spier 1650 Broadway, N.Y.C.
Marimba 100 W. 42nd St., N.Y.C.
Marian 756 Seventh Ave., N.Y.C.
Marine 50 Broadway, N.Y.C.
Mark VII 4024 Radford, N. H'wood, Cal.
Mark-Jules 23 Huron St., W. Hartford, Conn.
Markell 101 West 55th St., N.Y.C.
Marks, Gerald 140 West 57th St., N.Y.C.
Marlen 408 North Rodeo Dr., Beverly Hills, Cal.
Marnel 150 West 55th St., N.Y.C.
Marlene 735 East Rittenhouse St., Phila., Pa.
Marlo 10 East 40th St., N.Y.C.
Marlong 345 West 58th St., N.Y.C.
Marmaduke 8 East 48th St., N.Y.C.
Marmol 200 West 57th St., N.Y.C.
Marpet 10 Columbus Circle, N.Y.C.
Marquette 54 West Randolph St., Chicago, Ill.
Mars Records 10 Columbus Circle, N.Y.C.
Marster-Sound 11 Riverside Dr., N.Y.C.
Marti 1520 North Hayworth, H'wood, Cal.
Martin, James H. (Cadillac) 1341 South Michigan Ave., Chicago, Ill.
Martin 1467 North Vine St., H'wood, Cal.
Martin, William 1650 B'way, N.Y.C.
Marvin 1619 Broadway, N.Y.C.
Marx, Joseph 408 2nd Ave., N.Y.C.
Mary Jane 1650 Broadway, N.Y.C.
Maser 6940 Bay Dr., Miami Beach, Fla.
Mason 130 West 56th St., N.Y.C.
Massey 60 West 68th St., N.Y.C.
Matador Records (Ferdinand Div.) 607 Grant Bldg., Pitts., Pa.
Mathis, Johnny 1619 Broadway, N.Y.C.
Maurice, Peter 101 W. 55th St., N.Y.C.
Maxana 729 Seventh Ave., N.Y.C.
Maximum 159 West 49th St., N.Y.C.
May c/o Ross Jungnickel 1619 Broadway, N.Y.C.
Mayfair 31 West 54th St., N.Y.C.
Maypole 200 West 57th St., N.Y.C.
Mc Dougle 6122 Delongpre Ave., H'wood, Cal.
Mc Ginty 235 N. W. 57th Court, Miami, Fla.
McHugh & Adamson 609 Fifth Ave., N.Y.C.
Mc Hugh, Jimmy 6381 Hollywood Blvd., H'wood, Cal.
Meadowbrook 157 West 57th St., N.Y.C.
Mecca 1619 Broadway, N.Y.C.
Medallion 58 Market St., Newark, N.J.
Melanie 295 Madison Ave., N.Y.C.
Melhedd 1780 Broadway, N.Y.C.
Melker 2618 1/2 South Western Ave., L.A., Cal.
Mellin, Judi 1650 Broadway, N.Y.C.
Melo-Art 8983 Sunset Blvd., H'wood, Cal.
Melody 667 Madison Ave., N.Y.C.
Melomusic 1650 Broadway, N.Y.C.
Melrose 31 West 54th St., N.Y.C.
Memory 108 East 96th St., N.Y.C.
Memphis 71 Union, Memphis, Tenn.
Merrifield 134 North Detroit St., L.A., Cal.
Met Music 160 West 46th St., N.Y.C.
Metropolitan 1788 South Lacienege Blvd., L.A., Cal.
Mia 1650 Broadway, N.Y.C.
Michael's 4915 West Patterson Ave., Chicago, Ill.
Mick-Rick 928 51st St., Bklyn, N.Y.
Midway 157 West 57th St., N.Y.C.
Milbee 6223 Selma Ave., H'wood, Cal.
Milene 2510 Franklin Rd., Nashville, Tenn.
Milford Loudon Arms, Albany, N.Y.
Miljay 201 West 49th St., N.Y.C.
Miller 1540 Broadway, N.Y.C.
Miller-Pearce 8473 Melrose Ave., L.A., Cal.
Mills 1619 Broadway, N.Y.C.
Milnac 1739 De Camp Dr., Beverly Hills, Cal.
Mineo, Hess 1960 Ana Maria Pl., Palm Springs, Cal.
Miracle 1260 Sixth Ave., N.Y.C.
Miriam 119 West 57th St., N.Y.C.
Mitchell 1650 Broadway, N.Y.C.
Mivan 729 7th Ave., N.Y.C.
Midas 1773 Broadway, N.Y.C.
Mode Music c/o The Vincent Youmans Co. 157 West 57th St., N.Y.C.
Model P.O. Box 925, H'wood, Cal.
Modern 450 East 63rd St., N.Y.C.
Mogull, Ivan 1619 Broadway, N.Y.C.
Monarch 465 South Beverly Dr., Beverly Hills, Cal.
Monfly c/o Ross Jungnickel 1619 Broadway, N.Y.C.
Monitor 1619 Broadway, N.Y.C.
Monmar 11 Beacon St., Boston, Mass.
Monroco 6087 Sunset Blvd., H'wood, Cal.
Monsour 11125 South Wilton Pl., L.A., Cal.
Montemar 190 North Canon Dr., Beverly Hills, Cal.
Montez c/o Pacific Ent. 8715 West Third St., L.A., Cal.
Mood 666 Fifth Ave., N.Y.C.
Moon Tunes 1647 El Centro, H'wood, Cal.
Moorpark 119 West 57th St., N.Y.C.
Moral Re-Armanent 640 Fifth Ave., N.Y.C.
Morella 11758 Blix St., N. H'wood, Cal.
Morley 1739 De Camp Dr., Beverly Hills, Cal.
Morgil 1674 Broadway, N.Y.C.
Morley 31 West 54th St., N.Y.C.
Mormax 60 East 42nd St., N.Y.C.
Morris, Edwin H. 31 West 54th St., N.Y.C.
Morrissania 250 West 57th St., N.Y.C.
Moss, Herbert M. 2 West 46th St., N.Y.C.
Mt. Tom 1841 Broadway, N.Y.C.
Move 2114 Thurman Ave., L.A., Cal.
Movietone 11 West 60th St., N.Y.C.
Muirfield 250 W. 57 St., N.Y.C.
Mulcay 2700 Hollyridge Dr., H'wood, Cal.
Munrab 6256 De Longpre, H'wood, Cal.
Murray, Ted 138 East 35th St., N.Y.C.
Musetta 1048 North Carol Dr., L.A., Cal.
Musette 113 West 57th St., N.Y.C.
Music Hall 101 West 55th St., N.Y.C.
Musicland California Bank Bldg. 9441 Wilshire Blvd., Beverly Hills, Cal.
Music Makers 1606 Vista Del Mar, H'wood, Cal.
Music Mart 1617 North El Centro Ave., H'wood, Cal.
Music Prod. 9171 Wilshire Blvd., Beverly Hills, Cal.
Musicraft 1414 Brooklyn Ave., Bklyn, N.Y.
Music and Talent 80 Broadway, N.Y.C.
Music Workshop 1619 Broadway, N.Y.C.
Musical Works 69 West Washington St., Chicago, Ill.
Musi-Chord 1479 North Vine St., H'wood, Cal.
Musitronics 6087 Sunset Blvd., H'wood, Cal.
Mutual Entertainment Agency (Donna Div.) 203 North Wabash Ave., Chicago, Ill.
Mutual Music Society 609 Fifth Ave., N.Y.C.
Myers 1920 Chestnut St., Phila., Pa.
Myron 1341 Londonderry Pl., W. Hollywood 69, Cal.
Nacia 8929 Wilshire Blvd., Beverly Hills, Cal.
(Continued on next page)

APRIL/BLACKWOOD MUSIC PUBLISHING COMPANIES

JERRY TEIFER
General Manager

DAVID ROSNER
Professional Manager

CHIP TAYLOR
Associate Professional Manager

PRESENT THE FACES BEHIND THE HITS



Estelle Levitt

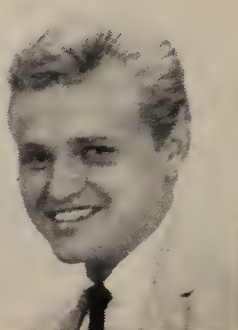

Chip Taylor



Van McCoy



Ted Daryll

WRITING EXCLUSIVELY FOR APRIL/BLACKWOOD

**MAKING
STRIDES**

THE WORLD-OVER



**THE
SCEPTER-WAND
ORGANIZATION**

**SCEPTER RECORDS
WAND RECORDS**

Florence Greenberg
Marvin Schlachter

SCEPTER-WAND INT'L

Joseph Zerga

WAND MANAGEMENT

Paul Cantor

FLOMAR MUSIC

Ed Silvers

SCEPTER-WAND RECORDS

254 W. 54th St.
New York, N. Y. 10019
Tel. (212) CI-5-2170
Cable: SCEPTERMUS

ASCAP PUBLISHERS

Nala 1674 Broadway, N.Y.C.
 Namelec 39 W. 54th St., N.Y.C.
 Nan-Paul 521 Fifth Ave., N.Y.C.
 Nascot 12610 Hortense St., Studio City, Cal.
 Nationwide 1674 Broadway, N.Y.C.
 Natson 850 Seventh Ave., N.Y.C.
 Neal P.O. Box 3294, San Bernardino, Calif.
 Neiberg, Al J. 821 W. 78th St., N.Y.C.
 Neila 6331 Hollywood Blvd., H'wood, Cal.
 Neilson 2 West 45th St., N.Y.C.
 Nelson 1717 North Highland Ave., H'wood, Cal.
 Newco Music 9350 Wilshire Blvd., Beverly Hills, Cal.
 New Hampshire 1501 Broadway, N.Y.C.
 New Man, Charles 328 South McCarty, Beverly Hills, Cal.
 Newman, Lee 11360 Dona Doratea Dr., Studio City, Cal.
 Newport 809 Little Bldg., 80 Boylston St., Boston, Mass.
 New Sounds In Modern Music 315 West 53rd St., N.Y.C.
 New World 488 Madison Ave., N.Y.C.
 New York 550 Fifth Ave., N.Y.C.
 Noble 1650 Broadway, N.Y.C.
 Noel 2360 South Veverly Glen Blvd., L.A., Cal.
 Nomat 600 Fifth Ave., N.Y.C.
 Norbett 12069 Ventura Pl., N. H'wood, Cal.
 North & Son 666 Fifth Ave., N.Y.C.
 Northern 445 Park Ave., N.Y.C.
 Northridge 6515 Sunset Blvd., H'wood Cal.
 Norwood 926 New Jersey Ave., NW, Washington, D.C.
 Noteworthy Radio City Music Hall, N.Y.C.
 Nothing 99 Lexington Ave., N.Y.C.

Oahu Box 5110, Cleve., Ohio
 Oak 1697 Broadway, N.Y.C.
 O'Connor and Miller 8779 West Pico Blvd., L.A., Cal.
 Octave Music 520 Fifth Ave., N.Y.C.
 Odette 2435 South Reese St., Phila., Pa.
 Odin 1234 North June St., H'wood, Cal.
 Official 1619 Broadway, N.Y.C.

O-Gee Hotel Bryant, 52nd St. & Broadway, N.Y.C.
 O'Kay 69 West Washington St., Chicago, Ill.
 Okun 104-40 Queens Blvd., Forest Hills 75, N.Y.
 Oleander Ent. 5880 Hollywood Blvd., H'wood, Cal.
 Oliver 200 W. 57th St., N.Y.C.
 Olman, Abe 10 Columbus Circle, N.Y.C.
 Olma Music 1650 Broadway, N.Y.C.
 Olschwanger, Berl 1531 Union Ave., Memphis, Tenn.
 Olympia 3005 Dudley Ave., Nashville, Tenn.
 Olympus 345 West 58th St., N.Y.C.
 Omar 5420 Melrose Ave., H'wood, Cal.
 Omell P.O. Box 232, Radio City Sta., N.Y.C.
 Orchestis 200 West 57th St., N.Y.C.
 Oriole 9157 Sunset Blvd., H'wood, Cal.
 Orlob 636 West 174th St., N.Y.C.
 Orten Lincoln Hotel, 1800 N. Lincoln Ave., Chicago, Ill.
 Ottilie 200 W. 57th St., N.Y.C.
 Oury, Mike 1450 South Michigan Ave., Chicago, Ill.
 Overbrook 1332 Philadelphia National Bank Bldg., Phila., Pa.
 Oviv 185 North Wabash Ave., Chicago, Ill.
 Owens-Kemp 5304 Calle Ventura, Phoenix, Ariz.
 Oxford Univ. 417 Fifth Ave., N.Y.C.
 P.D. 1138 N.E. 2nd Ave., Miami, Fla.
 P.D.S. c/o Robbins 1540 Broadway, N.Y.C.
 Pic 1650 Broadway, N.Y.C.
 P W 1425 North Dearborn Pkwy, Chicago, Ill.
 Pageant 7270-B Sunset Blvd., H'wood, Cal.
 Palace 1619 Broadway, N.Y.C.
 Paley 7900 Willow Glen Rd., L.A., Cal.
 Palm 333 Windsor Ave., L.A., Cal.
 Palm Springs 1601 N. Gower St., H'wood, Cal.
 Palmero 8321 Beverly Blvd., H'wood, Cal.
 Palomar 601 Northwest 195th Terrace, Miami, Fla.
 Pamill c/o Carlton Records 345 West 58th St., N.Y.C.
 Pemela 609 Fifth Ave., N.Y.C.
 Panorama 250 West 57th St., N.Y.C.
 Panther c/o Southern 1619 Broadway N.Y.C.
 Par 1472 Broadway, N.Y.C.
 Parakeet 1650 Broadway, N.Y.C.
 Paramount 1619 Broadway, N.Y.C.
 Paramount-Roy Rogers 1650 Broadway, N.Y.C.
 Par-Four 8665 Wilshire Blvd., Beverly Hills, Cal.
 Paris 1650 Broadway, N.Y.C.
 Park Ridge 200 East 66th St., N.Y.C.
 Parker 10850 Landale St., N. H'wood, Cal.
 Parliament 1619 Broadway, N.Y.C.
 Patore 1650 Broadway, N.Y.C.
 Pattern 6515 Sunset Blvd., H'wood, Cal.
 Patti 9350 Wilshire Blvd., Beverly Hills, Cal.
 Paxton, George 1619 Broadway, N.Y.C.
 Pell Mell 6229 Wilkinson Ave., N. H'wood, Cal.
 Penn 345 West 58th St., N.Y.C.
 Pepamar 488 Madison Ave., N.Y.C.
 Pepper, J. W. 1423 Vine St., Phila., Pa.
 Perrigo & Gayle 5712 Camellia Ave., N. Hollywood, Calif.
 Perrvin 7906 Santa Monica Blvd., H'wood, Cal.
 Petanden 420 Madison Ave., N.Y.C.
 Peters 150 West 55th St., N.Y.C.
 Petkere, Bernice 1612 North Argyle St., H'wood, Cal.
 Pett 525 Lexington Ave., N.Y.C.
 Phipps 57 West 56th St., N.Y.C.
 Photo Play 1674 Broadway, N.Y.C.
 Phyllis 1201 Taft Bldg., H'wood, Cal.
 Piantadosi 1569 South Spaulding Ave., L.A., Cal.
 Pic Music c/o Warock 400 Madison Ave., N.Y.C.
 Pickwick 322 West 48th St., N.Y.C.
 Picture c/o Ross Jungnickel 1619 Broadway, N.Y.C.
 Piedmont 136 West 52nd St., N.Y.C.
 Pilot 200 West 57th St., N.Y.C.
 Pincus, George 1650 Broadway, N.Y.C.
 Pine Ridge 1540 Broadway, N.Y.C.
 Pinkard 211 West 52nd St., N.Y.C.
 Pinkerton 10117 Washington Blvd., Culver City, Cal.
 Pinto, E. 64 East 55th St., N.Y.C.
 Piper 11449 Canton Dr., Studio City, Cal.
 Pivot 8854 Lookout Mt. Ave., H'wood, Cal.
 Plan Two 1619 Broadway, N.Y.C.
 Planetary 1621 Broadway, N.Y.C.
 Playback 1501 Broadway, N.Y.C.
 Players 609 Fifth Ave., N.Y.C.
 Playersville Box 46128, H'wood, Cal.
 Playhouse 1680 North Vine St., H'wood, Cal.
 Pleasant 68 Mechanic New Rochelle, N.Y.
 Pleasant Ridge Box 3691, Greenville, S.C.
 Plus-Minus 150 West 55th St., N.Y.C.
 Plymouth 1841 Broadway, N.Y.C.
 Pollsac 255 West 108th St., N.Y.C.
 Poncello 1412 23rd Avenue North, Nashville, Tenn.

Popular 165 West 46th St., N.Y.C.
 Positive 150 East 69th St., N.Y.C.
 Post 6425 Hollywood Blvd., H'wood, Cal.
 Preferred 225 Broadway, N.Y.C.
 Prentice 1501 Broadway, N.Y.C.
 Prentice-Hall P.O. Box 900, Englewood Cliffs, N.J.
 Prestige 2511 Mayberry St., H'wood, Cal.
 Prentiss-Clark 255 West 108th St., N.Y.C.
 Pride 810 Nat'l. City Bank Bldg., Cleveland, O.
 Princess 1650 Broadway, N.Y.C.
 Priscilla 1260 Sixth Ave., N.Y.C.
 Print 723 7th Ave., N.Y.C.
 Pro Music 1500 West 59th St., L.A., Cal.
 Producers 237 West 51st St., N.Y.C.
 Production 1674 Broadway, N.Y.C.
 Project (Marfram Div.) City National Bank Bldg., L.A., Cal.
 Prom 5404 Franklin Ave., H'wood, Cal.
 Promenade 6650 Sunset Blvd., H'wood, Cal.
 Protone 2847 Effie St., L.A., Cal.
 Putnam 609 Fifth Ave., N.Y.C.
 Pyramid 6087 Sunset Blvd., H'wood, Cal.

Quad Box 48484, L.A., Cal.
 Quartet 1619 Broadway, N.Y.C.
 Queen City Box 2588, H'wood, Cal.

"R" 4257 Bakman Ave., N. H'wood, Cal.
 R.F.D. 1619 Broadway, N.Y.C.
 Rae-Cox & Cooke 1697 Broadway, N.Y.C.
 Ragtime 1697 Broadway, N.Y.C.
 Raige Ent. (Griffon Pub. Div.) 110 Ocean Park Blvd., Santa Monica, Cal.
 Raimor 6381 Hollywood Blvd., H'wood, Cal.
 Rainbow 351 East 58th St., N.Y.C.
 Rajlon 157 West 57th St., N.Y.C.
 Randolph 6223 Selma Ave., H'wood, Cal.
 Randy-Smith 3941 Woodlawn Dr., Nashville, Tenn.
 Rap 7261 Willoughby Ave., L.A., Cal.
 Rapheal, Fred 6758 Colgate Ave., L.A., Cal.
 Raye 5425 West Division St., Chicago, Cal.
 Realm Music 1697 Broadway, N.Y.C.
 Recherche 473 West End Ave., N.Y.C.
 Recona 47 W. 57th St., N.Y.C.
 Record 1650 Broadway, N.Y.C.
 Record 450 West 24th St., N.Y.C.
 Redwine, Skip 9040 Rangely Ave., L.A., Cal.
 Reedlands 916 Kearny St., San Francisco, Cal.
 Regal 1429 Hawthorne St., Pittsburgh, Pa.
 Regaldi 279 Warwick Ave., Teaneck, N.J.
 Reliable 54 West Randolph St., Chicago, Ill.
 Reliance 1619 B'way, N.Y.C.
 Remick 488 Madison Ave., N.Y.C.
 Remsen, Alice 37 West 88th St., N.Y.C.
 Renaldo 407 Lincoln Road, Miami Beach, Fla.
 Renault 11360 Dona Doratea Dr., Studio City, Cal.
 Rene, Leon, c/o Recordo 6359 Selma Ave., H'wood, Cal.
 Rene, Otis 5048 Valley Ridge Road, L.A., Cal.
 Renee Time & Life Building, N.Y.C.
 Renhall 6365 Selma Ave., H'wood, Cal.
 Reo 3923 Jackson St., NE, Minn., Minn.
 Rest-A-While P.O. Box 78, Radio City Sta., N.Y.C.
 Revel, Harry 2435 Ocean Ave., Bklyn, N.Y.
 Revere 269 West 72nd St., N.Y.C.
 Revil 145 West 57th St., N.Y.C.
 Rex 6381 H'wood Blvd., L.A., Cal.
 Reynolds & Anthony 6500 Yuca St., H'wood, Cal.
 Reynolds 901 Eighth Ave., N.Y.C.
 Rhythm Ent. 2461 Creston Way, H'wood, Cal.
 Rialto Box 310-Cooper Sta., N.Y.C.
 Richard 1501 Broadway, N.Y.C.
 Richard Irwin 1650 Broadway, N.Y.C.
 Richion 250 South Broad St., Phila., Pa.
 Richter, William B., 6746 York Rd., Phila., Pa.
 Ricki 200 West 54th St., N.Y.C.
 Ricordi, G. 16 West 61st St., N.Y.C.
 Ric Tic 15004 Mack Ave., Detroit, Mich.

Ringle, Dave Wallpack, N.J.
 Rinimer Corp. 6400 Sunset Blvd., L.A., Cal.
 Rinn 328 Gerard Ave., Phila., Pa.
 Ritchie 1619 Broadway, N.Y.C.
 Ritter, Tex. 150 West 55th St., N.Y.C.
 Riverside 4720 Forman Ave., N. H'wood, Cal.
 Robar c/o Startford 237 West 51st St., N.Y.C.
 Robbee Records (Mary Jo Pub. Div.) Carlton House, Pitts., Pa.
 Robbins c/o Startford 237 W. 51st St., N.Y.C.
 Robbins, J. J. c/o Startford 237 West 51st St., N.Y.C.
 Robbins 1540 Broadway, N.Y.C.
 Robert 1650 Broadway, N.Y.C.
 Robertson, Don 1651 Cosmo St., H'wood, Cal.
 Roberty 1608 Hillhurst Ave., L.A., Cal.
 Robinson, H. B. 660 N. Broad St., Phila., Pa.
 Robinson, J. Russell 1619 Broadway, N.Y.C.
 Robran 1739 De Camp Dr., Beverly Hills, Cal.
 Roger 1790 Broadway, N.Y.C.
 Rojan 119 West 57th St., N.Y.C.
 Rolls 310 Madison Ave., N.Y.C.
 Roncom 1270 Sixth Ave., N.Y.C.
 Ronell, Ann 2281 De Soto Sta., Memphis, Tenn.
 Rosarita 1619 Broadway, N.Y.C.
 Rose, David, 5979 West Third St., L.A., Cal.
 Rosemeadow 1619 Broadway, N.Y.C.
 Rosemond 350 Fifth Ave., N.Y.C.
 Ross, Allan 4545 Talofa Ave., N. H'wood, Cal.
 Ross, Charles Mayflower Hotel, N.Y.C.
 Rossion 6047 Hollywood Blvd., H'wood, Cal.
 Rossi 1955 West 8th St., Bklyn, N.Y.
 Rossiter, Will 173 W. Madison St., Chicago, Ill.
 Round Table 1434 N. Genesee Ave., H'wood, Cal.
 R.D. Row 353 Newbury St., Boston, Mass.
 Roxbury 77 Crown St., Milton, Mass.
 Rual 1650 Broadway, N.Y.C.
 Rubank 5544 West Armstrong Ave., Chicago, Calif.
 Rub-Hall Sunset Vine Tower, H'wood, Cal.
 Ru'Jac 427 Laurens St., Balt., Md.
 Runnymede 6087 Sunset Blvd., H'wood, Cal.
 Russwill 1400 Bankers Securities Bldg. Phila., Pa.
 Ruxton 10 Columbus Circle, N.Y.C.
 Rylan 545 Fifth Ave., N.Y.C.
 Rytvoc 400 Madison Ave., N.Y.C.

SG 711 Fifth Ave., N.Y.C.
 S & R (Div. of Songs & Records) 6533 Hollywood Blvd., H'wood, Cal.
 SSS 200 W. 57th St., N.Y.C.
 Sacred Music Press of the Hebrew Union College—Jewish Institute of Religion 40 West 68th St., N.Y.C.
 Sacred Records (Sacred Songs Div.) 650 West Lamberi Road, Whittier, Cal.
 Saga 1619 Broadway, N.Y.C.
 Sage Prod. (Sage Div.) Box 44, Universal City, Cal.
 Sahara 609 Fifth Ave., N.Y.C.
 St. James 48 West 53rd St., N.Y.C.
 St. Nicholas 1619 Broadway, N.Y.C.
 Salter 2658 Woodhill Canyon Road, Studio City, Cal.
 Samson 400 East 59th St., N.Y.C.
 San-Dan 608 Fifth Ave., N.Y.C.
 San-Dee 3852 J St., Phila., Pa.
 San Dimo 1619 Broadway, N.Y.C.
 Sandra 1631 Broadway, N.Y.C.
 Sands 1619 Broadway, N.Y.C.
 Sanson 215 East 68th St., N.Y.C.
 Santee 165 West 10th St., N.Y.C.
 Sapphire 1619 Broadway, N.Y.C.
 Sarah 1650 Broadway, N.Y.C.
 Saturday 353 East 50th St., N.Y.C.
 Saunders 119 West 57th St., N.Y.C.
 Savitt 155 West 46th St., N.Y.C.
 Savoy 130 West 56th St., N.Y.C.
 Sawtell 5700 Rhodes Ave., N. H'wood, Cal.
 Scarsdale 666 5th Ave., N.Y.C.
 Schein 1674 Broadway, N.Y.C.
 Schillman 2317 West 80th St., Chicago, Ill.
 (Continued on next page)

WE'RE A NEW COMPANY ...

And We May Be Short on Age . . .

But We're Long on Experience.

BO-MAR ENTERPRISES, INC.

comprising

BO-MAR RECORDS

who bring you tomorrow's talent today . . .

Johnny Gilliam

Jimmy Merchant

Jimmy Interval

Phillip & Lee

INTERVALLEY MUSIC (BMI)

Attention, International Manufacturers and Publishers: We are interested in representation in your countries. Please contact us at



ENTERPRISES

550 Grant St.

Pittsburgh, Pa., U.S.A.

NAT a folio of songs recorded by NAT KING COLE

For B_b INSTRUMENTS (with Piano) 2.00
 For C INSTRUMENTS (with Piano) 2.00
 For E_b INSTRUMENTS (with Piano) 2.00
 For BASS CLEF INSTRUMENTS (with Piano) 2.00
 For ACCORDION 2.00
 For GUITAR 2.00
 For HARMONICA 1.50
 For MELODICA 1.50

Sole Selling Agent

FRED FISHER MUSIC CO., INC. 1619 BROADWAY NEW YORK, N.Y. 10019



TOP 100 LABELS

Amy	49	Laurie	88
A & M	24	Liberty	5
Arctic	41, 64	London	3, 48, 100
Argo	44	MGM	4, 31, 63, 65
Atco	1	Mala	97
Atlantic	13, 37	Mercury	32, 50, 74, 75
Aurora	36	Motown	11, 21, 25, 47
Autumn	40	Muscor	33
Bang	15, 93, 99	Old Town	70
Back Beat	100	Parkway	81
Brunswick	61	Parrot	2
Capitol	7, 8, 29, 39, 90	Philles	14, 45
Chess	62	RCA Victor	42, 56, 66, 77, 78, 79, 89
Colpix	95	Reprise	19, 43, 82
Columbia	9, 10, 17, 59, 73, 92	Ric Tic	58
DCP	23	Roulette	69
Decca	27, 51	Smash	38
Diamond	57	Soul	52
Dolton	83	Sue	72
Dunhill	80	Tamla	20, 34, 87
Epic	16, 30	Tower	55, 96
Four Bros.	86	United Artists	6, 22, 67
Gordy	35	Wand	53, 68, 71
Hickory	76	Warner Bros.	28, 85
Imperial	9, 12, 26, 54, 84, 94	White Whale	46
Kama Sutra	60		
Kapp	91, 98		
King	18		

LISTEN

to the clean,
cool sound of money as the

BELL RECORDS GROUP



tolls in another great year!

Distributor of these great labels:

AMY

AURORA

ADMIRAL

BELL

BIG TOP

DYNOVOICE

FLASHBACK

MALA

MAXX

NEW
VOICE

ROTATE

SPHERE
SOUND

SANSU

STREETCAR

VILLAGE
GATE

BELL RECORDS, INC. *the records with a ring of profits*
1776 Broadway, New York 10019

BOURNE COMPANIES
RECORDED SONGS

"Unforgettable"
SAMMY DAVIS Reprise
NAT KING COLE Capitol
LIVING STRINGS Camden
VIRKI CARR Liberty

"Smile"
ROBERT GOULET Columbia
SAMMY DAVIS Reprise
LIVING STRINGS Camden
MANTOVANI London

"This Is the Last Time"
(I'll Cry Over You)
LINDA BENNETT Victor
VIC DANA Liberty
THE MUSI-QUES Blue River

"Then I'll Be Happy"
JOE WILLIAMS Victor
MIKE DOUGLAS Epic

"Last Night When We Were Young"
FRANK SINATRA Reprise

"I Got No Strings"
BARBRA STREISAND Columbia

"When the Red Red Robin"
THELONIUS MONK Columbia
OSMOND BROS. MGM

"Me and My Shadow"
NELSON RIDDLE Reprise

"Lullaby of the Leaves"
THE VENTURES Dolton

"Oh How I Miss You Tonight"
BOBBY VINTON Epic

"That Old Gang of Mine"
DAMITA JO Epic
JIMMY ROSSELLI United Artists

"Little Brown Gal"
BURL IVES Decca

"Willow Weep for Me"
BRENDA LEE Decca
ROGER WILLIAMS Kopp
SAMMY KAYE Decca
BILLY VAUGHN Dot
LES & LARRY ELGART Columbia

"Tomorrow Night"
ELVIS PRESLEY Victor
CHARLIE RICH Victor
DAMITA JO Epic

"Bye Bye Blues"
AL HIRT Victor
JIMMY ROSSELLI United Artists

"I'm Confessin'"
THELONIUS MONK Columbia
VIC DANA Liberty

ABC MUSIC

"Rosanne"
BURT BACHARACH Gallant

"Imagination"
WALTER JACKSON Okeh

MURBO MUSIC

Hoop, Hoop, Hoop A Doo"
TITUS TURNER Murba

"Huckle Buckle Beanstalk"
TITUS TURNER Murba

"Darling Take Me Back"
LENNY WELCH Kopp
RAY POLLARD United Artists

BOURNE-FILMUSIC

"Tansy"
PEE WEE SPITELERA Victor

"Seance on a Wet Afternoon"
SIR JULIAN United Artists

BOURNE CO. 136 WEST 52 ST., N.Y., N.Y. 10019

ASCAP PUBLISHERS

Schirmer, E. C., 600 Washington St., Boston, Mass.

Schirmer, G., 609 Fifth Ave., N.Y.C.

Schroder 2027 Parkes St., Beakeley, Calif.

Schumann 980 North La Cienega Blvd., L.A., Cal.

Schwartz 35 West 45th St., N.Y.C.

Schwartz, Merrell 36 East Fifth St., Cincinnati, Ohio.

Scari 1201 S. Gramercy Pl., Los Angeles, Calif.

Scomar 370 Fulton Ave., Hempstead, L.I., N.Y.

Scott, Andrew 488 Madison Ave., N.Y.C.

Scott, Tony 875 West End Ave., N.Y.C.

Scott Michael 5900 N. Kentland, Woodland Hills, Calif.

Scroll Prod. 292 Madison Ave., N.Y.C.

Sea 1 Boylston Pl., Boston, Mass.

Sebiniano 285 East 49th St., Bklyn, N.Y.

Second 1619 Broadway, N.Y.C.

See Saw 35 West 53rd St., N.Y.C.

Segue 120 West 57th St., N.Y.C.

Select 1619 Broadway, N.Y.C.

Seneca 1042 West 81st St., L.A., Cal.

Sepe 6515 Sunset Blvd., Hollywood, Calif.

Sequence 48 West 48th St., N.Y.C.

Serena 333 Sixth Ave., N.Y.C.

Serio 1311 Needham Ave., N.Y.C.

Sewanee 8736 Sunset Blvd., L.A., Cal.

Seydell, Gypsy 2349 Devon Ave., Chicago, Ill.

Shale 1650 Broadway, N.Y.C.

Shamrock 1166 Springfield Ave., New Providence, N.J.

Shank, Bud c/o Jimmy McHugh 6381 Hollywood Blvd., H'wood, Cal.

Shapiro, Ted 695 N. E. 151st St., Miami, Fla.

Shapiro, Bernstein 666 Fifth Ave., N.Y.C.

Sharkey 505 Park Ave., N.Y.C.

Shari 120 West 57th St., N.Y.C.

Shattinger c/o Hansen 601 5th Ave., N.Y.C.

Shaw, Eddie 9128 Sunset Blvd., L.A., Cal.

Shawn 1697 B'way, N.Y.C.

Shawnee Delaware Water Gap., Pa.

Shay c/o Jimmy McHugh 6381 Hollywood Blvd., H'wood, Cal.

Shayne, Larry 1003 Sunset Vine Tower Bldg., Hollywood, Calif.

Shearing 11525 La Maida St., N. Hollywood, Calif.

Shefter, Bert 9255 Sunset Blvd., Suite 609, L.A., Calif.

Shelia 234 W. 56th St., N.Y.C.

Shelley 875 Fifth Ave., N.Y.C.

Shelley, David 150 West 55th St., N.Y.C.

Sheridan 230 Riverside Dr., N.Y.C.

Sheriton 6223 Selma Ave., Suite 204, Hollywood, Calif.

Sherman, Al 700 S. Hobart Blvd., Apt. 305, L.A., Calif.

Sherwin 1650 Broadway, N.Y.C.

Shilkret, Nathaniel Box 38 Malverne, N.Y.

Shoreham c/o General Music Corp. 1041 No. Formosa Ave., H'wood, Cal.

Show Tunes 1270 Sixth Ave., N.Y.C.

Shubert 488 Madison Ave., N.Y.C.

Shuman, Alden 341 Madison, N.Y.C.

Siana Prod. 781 7th Ave., N.Y.C.

Sight & Sound 6404 Hollywood Blvd., Hollywood, Calif.

Sigma 1619 Broadway, N.Y.C.

Silent 2109 B'way, Suite 1177, N.Y.C.

Silhouette 601 5th Ave., N.Y.C.

Silvertowne c/o Ross Jungnickel 1619 Broadway, N.Y.C.

Simon, George 250 W. 57, N.Y.C.

Sing N' Dance 68 Mechanic, New Rochelle, N.Y.

Siras 39 West 54th St., N.Y.C.

Sitara 1915 24th Rd., Astoria, N.Y.

Sixty Two Revue 240 West 55th St., N.Y.C.

Skidmore 666 Fifth Ave., N.Y.C.

Skinner Box 671, H'wood, Cal.

Skip 1722 Washington Ave., St. Louis, Mo.

Skyview 9165 Sunset Blvd., L.A., Calif.

Slen 818 6th St., Union Beach, N.J.

Smith-Foley 610 Cathedral Parkway, N.Y.C.

Smith, Fthel 601 5th Ave., N.Y.C.

Smith, Wm. J., 254 West 31st St., N.Y.C.

Snyder 1483 North Vine St., H'wood, Cal.

Soifer 1697 B'way, N.Y.C.

Somerset 12831 St. N. H'wood, Cal.

Sovarama 2033 Beachwood Dr., Hollywood, Calif.

Song-Art 1650 Broadway, N.Y.C.

Songfest 1650 Broadway, N.Y.C.

Song Shop 173 West Madison St., Chicago, Ill.

Songs 4236 Alcoeve, Studio City, Cal.

Songsellers 1619 B'way, N.Y.C.

Songsmiths 1650 Broadway, N.Y.C.

Soon 4055 Wilshire Blvd., Los Angeles, Cal.

Soremy 250 West 57th St., N.Y.C.

SoSo 628 W. Vernon Ave., L.A., Calif.

Sound & Light 35 W. 53rd St. N.Y.C.

Sound-O-Rama 1440 Broadway, N.Y.C.

Soundpost 601 5th Ave., N.Y.C.

Sounds 1619 B'way, N.Y.C.

Sounds Unlimited c/o Frank Barone 4055 Wilshire Blvd., L.A., Calif.

Southdale 1003 Sunset Vine Tower Bldg., Hollywood, Calif.

Southern 1619 Broadway, N.Y.C.

Southern 1100 Broadway, San Antonio, Tex.

South Sea 4948 Fulton Ave., Sherman Oaks, Cal.

Southwest 1951 Holby Ave., L.A., Cal.

Souvenir Box 1725, H'wood, Cal.

Sovereign 222 E. 49th St., N.Y.C.

Spar 36 Central Park So., N.Y.C.

Sparatan 1614 North Argyle, H'wood, Cal.

Spectacular 30 Rockefeller Plaza, N.Y.C.

Spectorious 161 West 54th St., N.Y.C.

Spencer, Glenn 1595 Crossroads of the World, H'wood, Cal.

Spencer 507 Fifth Ave., N.Y.C.

Spielman 51 West 81st St., N.Y.C.

Spier, Larry 1650 Broadway, N.Y.C.

Spar 36 Central Park So., N.Y.C.

Spina 2232 Vista Del Mar Place, H'wood, Cal.

Spiral Record 875 Fifth Ave., N.Y.C.

Spitzer, Henry 200 Madison Ave., N.Y.C.

Spoone 9033 Wilshire Blvd., Beverly Hills, Cal., 205 West End, N.Y.C.

Stacy 1918 S. Prairie Ave., Chicago, Ill.

Stada c/o Walter Hober 150 West 55th St., N.Y.C.

Stage Craft 551 Fifth Ave., N.Y.C.

Standish 1270 Sixth Ave., N.Y.C.

Stanley 9171 Wilshire Blvd., Beverly Hills, Cal.

Stan-Mar c/o Commander 1610 North Argyle Ave., H'wood, Cal.

Starbright 160 West 59th St., N.Y.C.

Stargen 11 West 60th St., N.Y.C.

Starlight 2211 Bowmount Dr., Beverly Hills, Calif.

Startime 6313 Peach Ave., Van Nuys, Cal.

Stasny 1619 Broadway, N.Y.C.

State 1619 Broadway, N.Y.C.

Stearns, Juian South Road, Harrison, N.Y.

Steeple-Tone 222 West 49th St., N.Y.C.

Stein & Van Stock, 2648 W. Grand Blvd., Detroit, Mich.

State 1619 Broadway, N.Y.C.

Steeple-Tone 222 West 49th St., N.Y.C.

Stelzer 1732 Whitley Ave., H'wood, Cal.

Stephens, Bob 54 West 58th St., N.Y.C.

Stepping Tones P.O. Box 64334, L.A., Cal.

Steps 638 North Belair Dr., Burbank, Cal.

Stitt 215 West Fifth St., L.A., Cal.

Stride 1619 Broadway, N.Y.C.

Stormont c/o M. G. M. 1540 Broadway, N.Y.C.

Startford 327 West 51st St., N.Y.C.

Stratford 609 Fifth Ave., N.Y.C.

Stroud 1650 Broadway, N.Y.C.

Stuart, Frank 1721 Broadway, N.Y.C.

Studio P.O. Box 46, Radio City Sta., N.Y.C.

Styne & Cahn 132 S. Rodeo Rd., Beverly Hills, Calif.

Suchan 1651 Cosmo, H'wood, Cal.

Sujan 39 West 60th St., N.Y.C.

Sulky 729 7th Ave., N.Y.C.

Summit 1619 Broadway, N.Y.C.

Sunflower 1619 Broadway, N.Y.C.

Sunset 1674 Broadway, N.Y.C.

Superb 1650 B'way, N.Y.C.

Supreme 1619 Broadway, N.Y.C.

Surrey 1674 Broadway, N.Y.C.

Sutton 415 East 52nd St., N.Y.C.

Swarthmore 1619 Broadway, N.Y.C.

Sweatman, Wilbur 1674 Broadway, N.Y.C.

Swingersville 6223 Selma Ave., H'wood, Cal.

Swing House 12130 Sherman Way, N. Hollywood, Calif.

Sylvan 323 Cedar Street, NW, Wash., D.C.

Symphony House c/o Paul Siegel Taunentzien Strasse 16, Berlin W. 30, Germany

Syosset 15 Brookwood Dr., Wyandanch, L.I., N.Y.

T-G c/o Tom Gribble 11714 Buckeye Rd., Cleveland, Ohio

TPI 4440 Lakeside Dr., Burbank, Cal.

T V 1650 Broadway N.Y.C.

Tad P.O. Box 1958, GPO, N.Y.C.

Tadmal 490 Westend Ave, N.Y.C.

Tahiti 1023 North La Brea Ave., L.A., Cal.

TAJ 1813 N. Vine St., Hollywood, Calif.

Talent 2424 South Broad St., Phila., Pa.

Talent, Leo 1650 Broadway, N.Y.C.

Talisman 9107 Wilshire Blvd., Beverly Hills, Cal.

Tamarisk 1332 1/2 Miller Dr., L.A., Cal.

Tamarin 8 E. 48th St., N.Y.C.

Tanda 10 East 49th St., N.Y.C.

Tanglewood 295 Madison Ave., N.Y.C.

Tape 6051 Harold Way, H'wood, Cal.

Tape 666 Hancock, Brooklyn, N.Y.

Tara 136 West 46th St., N.Y.C.

Tarpon 1631 Broadway, N.Y.C.

Tate 666 Hancock St., Brooklyn, N.Y.

Taubman, Paul 16 East 62nd St., N.Y.C.

Taurus Los Angeles Athletic Club, 431 West 7th St., L.A., Cal.

Taylor, Larry 136 West 52nd St., N.Y.C.

Teena 142 E. 34th St., N.Y.C.

Tee Pee 1650 Broadway, N.Y.C.

Teesdale 1479 North Vine St., H'wood, Cal.

Tele-Film 140 S. Sepulveda Blvd., L.A., Calif.

Teleklew 2444 Wilshire Blvd., Santa Monica, Cal.

Templeton c/o Shawnee Press, Delaware Water Gap, Pa.

Tempo 13310 Caine St., Cleveland, O.

Tempo 52 West 58th St., N.Y.C.

Tempo 1650 Broadway, N.Y.C.

Tempo Record Company of Amer. (Holloway House Div.) 8766 Holloway Dr., H'wood, Cal.

Tennyson 1617 R'dge Ave., Evanston, Ill.

Tepper, Saul 79 Barrow St., N.Y.C.

Terrell 32 West 82nd St., N.Y.C.

Teri 1491 N. Vine St., Hollywood, Calif.

Terrace 173 W. Madison St., Chicago, Ill.

Terry c/o Ben Arrigo 157 West 57th St., N.Y.C.

Terton 120 E. 56th St., N.Y.C.

Thank P. O. Box 416, N.Y.C.

Thirty Seven 6715 W. Olympic Blvd., Los Angeles, Cal.

Thomas, John 608 Fifth Ave., N.Y.C.

Thompson, Kay 9 East 62nd St., N.Y.C.

Thompson-Ray P. O. Box 944, H'wood, Cal.

Thornhill 67 West 44th St., N.Y.C.

Thornlee 1650 Broadway, N.Y.C.

Three Dee 3205 Bonnie Hill Dr., H'wood, Cal.

Threesome 12660 Mulholland Dr., Beverly Hills, Cal.

Thunderbird 6515 Sunset Blvd., H'wood, Cal.

Thur-Bill 1743 So. La Brea, H'wood, Cal.

Tilbilly 5 West 86th St., N.Y.C.

Timber 1617 El Centro Ave., H'wood, Calif.

Timel 1650 Broadway, N.Y.C.

Tivoi 9601 Wilshire Blvd., Beverly Hills, Cal.

T'NT 9889 Santa Monica Blvd., Beverly Hills, Calif.

Tohey 1650 Broadway, N.Y.C.

Tobias & Lewis 1650 Broadway, N.Y.C.

Tod 632 Winchester Ave., Union, N.J.

Tomad 39 West 55th St., N.Y.C.

Tomard 79 W. Monroe St., Chicago, Ill.

Tone 5 Tudor City Pl., N.Y.C.

Top Notch 1619 Broadway, N.Y.C.

Topper 119 West 57th St., N.Y.C.

Tor 408 North Rodeo Dr., Beverly Hills, Cal.

Torch Prod. c/o Monmouth-Lee 730 Fifth Ave., N.Y.C.

Totem P.O. Box 3194, N.Y.C.

Touchstone 5927 Sunset Blvd., H'wood, Cal.

Touring 55 E. 74th St., N.Y.C.

Towne 1619 Broadway, N.Y.C.

Toy Town 1841 Broadway, N.Y.C.

Trafalgar 200 W. 57th St., N.Y.C.

Tracer c/o Reco-Art Recording 212 North 12th St., Phila., Pa.

Tracie P.O. Box 849, Beaumont, Tex.

Trans American 1619 Broadway, N.Y.C.

Transcontinental 1674 Broadway, N.Y.C.

Tray 135 West 50th St., N.Y.C.

Traylmore 515 Madison Ave., N.Y.C.

Triana 1639 Broadway, N.Y.C.

Triangle 1619 Broadway, N.Y.C.

(Continued on next page)

Best Wishes

Johnny Mercer Marshall Robbins

COMMANDER PUBLICATIONS

1610 N. Argyle Ave.
Hollywood 28, Calif.
469-0878



(FOR WORLD-WIDE REPRESENTATION)

IVAN MOGULL

1619 BROADWAY NEW YORK
CABLE: IMOGULL

The Kingsmen — Ian Whitcomb — Sir Raleigh — Dave Lewis —
Don & Goodtimes — Robin Kingsley — Rocky & His Friends —
Tikis & Fabulons — Bobby Wayne.....

just a few of the artists that make

JERRY DENNON & JERDEN PRODUCTIONS
One of the hottest companies in the business!



MUSIC INC. Phone: Main 2-0470
2227 Fifth Avenue, Seattle, Washington 98121

"MR. GUITAR" **CHET ATKINS**



CURRENT
ALBUM

#1

**MOST PROGRAMMED
INSTRUMENTALIST
COUNTRY - 1965.
Cash Box DJ Poll**

EXCLUSIVELY

RCA VICTOR

RCA The most trusted name in sound 



**SOUTHERN MUSIC PUB.
CO. INC.
PEER INTERNATIONAL
CORPORATION**

**CHAS. K. HARRIS MUSIC PUBLISHING
CO., INC.**

**IVER RECORDING CORP.
LA SALLE MUSIC PUBLISHERS, INC.
MELODY LANE PUBLICATIONS, INC.
PANTHER MUSIC CORP.
PERA MUSIC CORP.
R.F.D. MUSIC PUBLISHING CO. INC.
NEW YORK-CALIFORNIA
TENNESSEE-FLORIDA**

**OFFICES IN MAJOR MUSIC
CENTERS OF THE WORLD**

ARGENTINA

—Buenos Aires

AUSTRALIA

—Sydney, N.S.W.

AUSTRIA

—Vienna

BELGIUM

—Brussels

BRAZIL

—Rio de Janeiro

CANADA

—Montreal, P.Q.

CHILE

—Santiago de Chile

COLOMBIA

—Bogota

FRANCE

—Paris

GERMANY

—Hamburg

GREAT BRITAIN

—London

HOLLAND

—Amsterdam

ISRAEL

—Tel Aviv

ITALY

—Milan

JAPAN

—Tokyo

MEXICO

—Mexico City

NEW ZEALAND

—Auckland

PUERTO RICO

—Santurce

SOUTH AFRICA

—Johannesburg

SPAIN

—Barcelona & Madrid

SWEDEN

—Stockholm

SWITZERLAND

—Zurich

VENEZUELA

—Caracas

**Mrs. RALPH PEER
President**

PROFESSIONAL DIVISION

LUCKY CARLE PAUL BARRY

ROY HORTON



ASCAP PUBLISHERS

Tribute Heller 345 West 52nd St., N.Y.C.
Tricky 1631 Broadway, N.Y.C.
Trinda 142 Fifth Ave., N.Y.C.
Trine 48 West 53rd St., N.Y.C.
Troubadour 404 West 57th St., N.Y.C.
Trulite 117 West 70th St., N.Y.C.
Tucker, Orrin 15475 Hammer Dr., L.A., Cal.
Tulip 1650 Broadway, N.Y.C.
Tune-House 1674 Broadway, N.Y.C.
Ulan 729 7th Ave., N.Y.C.
Two Dees 351 N. Palm Dr., Beverly Hills, Cal.
Tycom 1674 Broadway, N.Y.C.
Tylerson 150 West 55th St., N.Y.C.
U.S. Songs c/o Quartet 1619 Broadway, N.Y.C.
Ulan 729 7th Ave., N.Y.C.
Umbrella 3011 Beach 40th St., Brooklyn, N.Y.
United Artists 729 Seventh Ave., N.Y.C.
United 1631 Broadway, N.Y.C.
United Int'l Representatives 120 E. 56th St., N.Y.C.
University 1650 Broadway, N.Y.C.
UPA 4440 Lakeside Dr., Burbank, Cal.
Urban 1177 W. Jefferson Blvd., L.A., Cal.
Valando 22 West 48th St., N.Y.C.
Valbo 161 West 54th St., N.Y.C.
Valencia 1650 Broadway, N.Y.C.
Valentine 1697 Broadway, N.Y.C.
Valentino, Thomas 150 West 46th St., N.Y.C.
Valiant 1619 Broadway, N.Y.C.
Valley Brook 2733 Kensington Ave., Phila., Pa.
Valley Entertainment Ent. 708 North Camden Dr., Beverly Hills, Cal.
Valyr 545 Fifth Ave., N.Y.C.
Vanderbilt 22 E 49th St, NYC
Vanessa 1650 Broadway, N.Y.C.
Vandie 2480 16th St. N.W., Washington, D.C.
Van Hall 1040 N. Las Palmas Ave., Hollywood, Calif.
Van Heusen 250 W. 57, N.Y.C.
Vanilla 314 Binkley Dr., Nashville, Tenn.
Vanlee 1270 Sixth Av., N.Y.C.
Vanno 150 West 55th St., N.Y.C.
Variety 1640 Broadway, N.Y.C.
Vero 41 E. 42nd St., N.Y.C.

Varona 5400 Fieldstone Rd., N.Y.C.
Veda 5177 Pickford, L.A., Cal.
Vended 857 Wilcox H'wood, Cal.
Venus 1619 Broadway, N.Y.C.
Vera Nova 720 N. Roxbury Dr. Beverly Hills, Cal.
Verna 930 F. Street, N.W., Wash., DC
Vernon 1619 Broadway, N.Y.C.
Veronique 250 West 57th St., N.Y.C.
Versil 10736 Magnolia Blvd., N. H'wood, Cal.
Vibes c/o Jay Cooper 315 S. Beverly Dr., Beverly Hills, Calif.
Vicar 90 Riverside Dr., N.Y.C.
Vickers 6381 Hollywood Blvd., L.A., Cal.
Victoria 295 Madison Av., N.Y.C.
Victoria 488 Madison Av., N.Y.C.
VicVegas 116 S. 4th St., Las Vegas, Nev.
Vier, Shelly, P.O. Box 728, H'wood, Cal.
Vi-Jim 150 West 55th St., N.Y.C.
Villa Moret 785 Market St., San Fran, Cal.
Vim 9 Rockefeller Plaza, N.Y.C.
Vine St. 1549 N. Vine St., Hollywood, Calif.
Vinrob 501 Madison Av., N.Y.C.
Vin-Sun 1507 N. Vine St., H'wood, Cal.
Virtu 8500 Favette St., Phila., Pa.
Vista 309 W. 57th St., N.Y.C.
Vitalent, 165 West 66th St., N.Y.C.
Vogel, Jerry 112 W. 44th St., N.Y.C.
Volkwein Bros. 632-34 Liberty Av., Pittsburgh, Pa.
Vota 333 S. Windsor Blvd., L.A., Cal.
Vonzell's 5238 1/2 W. Adams Blvd., L.A., Cal.
Voss 1693 Crossroads of the World, L.A., Cal.

WPVC 190 Waverly Pl., N.Y.C.
Walk, Henry Z. 19 Union Square W., N.Y.C.
Wald, Herb 6083 Sunset Blvd., H'wood, Cal.
Walden 1841 Broadway, N.Y.C.
Waldo 1619 Broadway, N.Y.C.
Wallan, c/o Lawson-Gould 609 Fifth Av. NYC
Walton 132 S. Rodeo Dr., Beverly Hills, Calif.
Wanderlust Records (Wanderlust Div) 8640 Wonderland Av., L.A., Cal.
Wangir 351 West 52nd St., N.Y.C.
Wan-Mar 154 W. 54th St., N.Y.C.

Warcov 271 Madison Av., N.Y.C.
Ward, Jay 8218 Sunset Blvd., H'wood, Cal.
Waredown 1199 So. Bronson, L.A., Cal.
Warnow, Mark 4042 Benedict Canyon Dr. Sherman Oaks, Cal.
Warock 39 W. 54th St., N.Y.C.
Warwick 1132 S. Rodeo Dr., Beverly Hills, Cal.
Washington & Lee 1712 Angelo Dr. Beverly Hills, Cal.
Wayfarer 580 W. End Av., N.Y.C.
Webster 132 S. Rodeo Dr., Beverly Hills, Cal.
Webster & Lee 200 N. Edison, Burbank, Cal.
Wedge Wood 444 N. Camden Dr., Beverly Hills, Calif.
Weil-Brecht-Harms 488 Madison Av., N.Y.C.
Weintraub 240 W. 55th St., N.Y.C.
Weiss, Sam 6087 Sunset Blvd., H'wood, Cal.
Wellington 1674 Broadway, N.Y.C.
Wells 19 W. 44th St., N.Y.C.
Welz, 2203 Maryland Ave., Baltimore, Md.
Weizheim 234 E. 61 St., N.Y.C.
Wemy 1619 Broadway, N.Y.C.
Wendy 1650 Broadway, N.Y.C.
Wentworth 65 E. 55th St., N.Y.C.
Wes Mar 31 W. Market St., Akron, Ohio
Wespo 392 Central Park W., N.Y.C.
Wess, Richard 608 Fifth Av., N.Y.C.
West, Ray 2411 Webb Ave, Bronx, N.Y.
West Coast 8715 W. 3rd St., L.A., Cal.
West End 1650 Broadway, N.Y.C.
Westmont 1003 Sunset Vine Tower Bldg., Hollywood, Calif.
West'n 1556 N. La Brea Av., H'wood, Cal.
West'r'n 1000 Riverside Dr., N., H'wood, Cal.
Whale 229 E. 52nd St., N.Y.C.
Wharton 206 S. 13th St., Philadelphia, Pa.
Whitecup, Leonard 215 E. 68th St., N.Y.C.
White Way 101 W. 55th St., N.Y.C.
Whitney-Kramer-Zaret 1650 Broadway, N.Y.C.
Williamson 609 Fifth Av., N.Y.C.
Wilbee 160 Wood St., Wilkes Barre, Pa.
Willow 200 W. 57th St., N.Y.C.
Willowgreen 9 W. 87th St., N.Y.C.
Wilshire 9423 Beverlywood St., L.A., Cal.
Wimbledon P. O. Box 1261, G.C.S., N.Y.C.
Windy City 14 E. Jackson, Chicago, Ill.
Winslow 890 Sixth Av., N.Y.C.
Winston 315 N. Martel Av., L.A., Cal.
Wintergreen 162 E. 55th St., N.Y.C.
Winterset, c/o Valando 22 W. 48th St., N.Y.C.
Winton House 9808 Wilshire Blvd, Beverly Hills, Cal.
Wise Music 1650 Broadway, N.Y.C.
Witmark, M., 488 Madison Av., N.Y.C.
Wizell, Murray 15 Central Park West, N.Y.C.
Wolper 8720 Sunset Blvd., L.A., Cal.
Wood, B. F. 1619 Broadway, N.Y.C.
Woodbine 11224 Bellagio Rd., L.A., Cal.
Wood River 940 Wood River Rd., Dallas, Tex.
Woodrow 200 W. 57th St., N.Y.C.
Woodvale 132 S. Rodeo Dr., Beverly Hills, Cal.
Woodward 200 W. 58th St., N.Y.C.
Wooftie c/o Ross Jungnickel 1619 Broadway, N.Y.C.
Word 2033 Beachwood Dr., Hollywood, Calif.
Words & Music 1841 Broadway, N.Y.C.
World 1619 Broadway, N.Y.C.
Worth, Bobby 554 Fifth Ave., N.Y.C.
Wynne Records (Gailacy Div) Barclay Bldg., 1 Belmont Ave., Bala-Cynwyd, Pa.
Wynnfield 128 S. Reeves Dr., Beverly Hills, Cal.

**Philco Accessory Div.
Tioga & "C" Sts.
Philadelphia, Pa.**

**Pro-Sound Corp.
175—5th Ave.
New York 10, N. Y.**

**Wm. J. Purdy Co.
312 Seventh St.
San Francisco, Calif.**

**Qualitone
102 Columbus Ave.
Tuckahoe, N. Y.**

**Recoton Corp.
46-23 Crane St.
Long Island City, N. Y.**

**Robins Industries
41-08 Bell Blvd.
Bayside, N. Y.**

**Seebro Dist.
2019 S. Michigan Ave.
Chicago 16, Ill.**

**Tone King Corp.
65-55 Grand Ave.
Maspeth 78, N. Y.**

**Top Records
83 Crosby St.
New York, N. Y.**

**United Audio Products
202 East 10th St.
New York, N. Y.**

**Walco Electronics
60 Franklin St.
East Orange, N. J.**

MANUFACTURERS OF CLEANERS, CLOTHS AND BRUSHES

**Astatic
Conneaut, Ohio**

**Audiotex Mfg. Co.
400 So. Wyman St.
Rockford, Ill.**

**Paul Bennett Co.
230 E. Ohio
Chicago 11, Ill.**

**Bradley's
9130 Firestone
Downey, Calif.**

**Cadie Chemical Products, Inc.
603 West 130th St.
New York 27, N. Y.**

**Chamrox Record Cleaner
P. O. Box 532
Rochester, N. Y.**

**Chem Wipe
Manard Products
9 Echo Ave.
New Rochelle, N. Y.**

**Dexter Chemical Corp.
819 Edgewater Rd.
New York 59, N. Y.**

**Duotone Co., Inc.
Locust St.
Keyport, N. J.**

**EBY Sales
130 Lafayette St.
New York, N. Y.**

**Electro-Sonic Labs
35-54—36th St.
Long Island City, N. Y.**

**Elsam Products
P. O. Box 417
Brockton, Mass.**

**Fidelltone, Inc.
6415 Ravenswood Ave.
Chicago 26, Ill.**

**Fine-Tone Audio Products Co.
7111 20 Ave.
Brooklyn 4, N. Y.**

**Interelectronics Corp.
2432 Grand Concourse
New York 58, N. Y.**

**Jensen Industries
7333 W. Harrison
Forest Park, Ill.**

**Kirsch Music Corp.
349 W. 48th St.
New York 36, N. Y.**

**Kroll Trading Co.
133 Greene St.
New York 12, N. Y.**

**Le-Bo Products Co.
418 W. 49th St.
New York 19, N. Y.**

**Levbo Products Co. Inc.
349 West 48 St.
New York 36, N. Y.**

**LeMire Products
204 West 55th St.
New York, N. Y.**

**Librascope, Inc.
40 E. Verdugo St.
Burbank, Calif.**

**Lindberg Products
326 E. 70 St.
New York, N. Y.**

**Manard Products, Inc.
9 Echo Ave.
New Rochelle, N. Y.**

**J. W. Marsh Co.
4216 W. Jefferson Blvd.
Los Angeles, Calif.**

**Merit Products
P. O. Box 56
Highbridge Sta.
New York 52, N. Y.**

**Merlx Chemical Co.
2234 E. 75th St.
New York, N. Y.**

**M. A. Miller Mfg. Co.
4th & Church Sts.
Libertyville, Ill.**

**Nuclear Products
10173 E. Rush St.
El Monte, Calif.**

**Olympia Manufacturing
721—11th Ave.
New York 19, N. Y.**

**Ortho-Sonic Instruments
66 Mechanic St.
New Rochelle, N. Y.**

**Pfsantlehl Chemical Corp.
104 Lake View Ave.
Waukegan, Ill.**

(Con't on Next Column)

**THE HAPPY SOUND
IS THE NEW RAY CONNIFF SINGLE
"HAPPINESS IS" 4-43352**

**THE BIG SOUND
IS THIS RAY CONNIFF ALBUM**

RAY CONNIFF
AND THE SINGERS
MUSIC FROM
MARY POPPINS

FEATURING THE ACADEMY AWARD WINNER "CHIM CHIM CHER-EE"

THE SOUND OF MUSIC
MY FAIR LADY
AND OTHER GREAT MOVIE THEMES

A SPOONFUL OF SUGAR	THE SOUND OF MUSIC
CHIM CHIM CHER-EE	MY FAVORITE THINGS
SUPERCALIFRAGILISTICEXPIALIDOCIOUS	CLIMB EV'RY MOUNTAIN
FEED THE BIRDS	ON THE STREET WHERE YOU LIVE
JOLLY HOLIDAY	I'VE GROWN ACCUSTOMED TO HER FACE
PASS ME BY	DEAR HEART

CL 2366/CS 9166 STEREO

**THE SELLING SOUND
IS RAY CONNIFF
ON COLUMBIA RECORDS **

BMI PUBLISHERS

A. & A 24-19 95th E. Elmhurst, N.Y.
A.D.T. 250 W. 57 N.Y.C.
A. E. B. 1041 North Formosa Hollywood
A-1 Hotel Monterey Broadway & 94th N.Y.C.
A-Z 2332 Vista Del Mar Hollywood
Aaron 5759 Columbus Van Nuys, Cal.
Abadan 2018 Terrace Pl. Nashville, Tenn.
Bob Abbott c/o Roosevelt Music 1650 Broadway, N.Y.C.
Abco P.O. Box 1224 Nashville, Tenn.
Abel 507 Fifth N.Y.C.
Abingdon Press 201-8th Ave. S., Nashville, Tenn.
Abner 12903 Brackland Cleveland, O.
Academy 735 Santa Barbara Pasadena, Cal.
Acama 1608 Argyle Hollywood
Acapulco 2419 Burnside, L.A., Cal.
Accent 306 Third Columbus, Ind.
Acclaim, P.O. Box 128 Madison, Tenn.
Ace 203 W. Capitol Jackson, Miss.
Aceman 24-16 Bridge Plaza, N.Y.C.
Acklen 617 Exchange Building Nashville, Tenn.
Acme 1650 Broadway, N.Y.C.
Acorn 10 Columbus Circle, N.Y.C.
Acre 9171 Wilshire Blvd. Beverly Hills
Actual 1650 Broadway, N.Y.C.
Acuff-Rose 2510 Franklin Nashville, Tenn.
Adair 6158 Westminster, Houston, Texas
Adams 1697 Broadway, N.Y.C.
Adams-Ethridge Box 434 Galveston, Texas
Adams-Vee & Abbott 216 S. Wabash Ave., Chicago
Adanac (BMI Can.)
Adaris see T. M.
Addison see Trinity
Adelphi Press Box 2045, Hollywood
Adept 715 E. 111 Place, L.A., Cal.
Larry Adler 145 W. 57, N.Y.C.
Admiration 3432 Mentone, L.A., Cal.
Adonis 10 Columbus Circle, N.Y.C.
Adway, 1650 B'way, N.Y.C.
Aero 2400 West Madison Chicago
Affiliated 1619 Broadway, N.Y.C.
Agard 247 West 46, N.Y.C.
Agate 1650 Broadway, N.Y.C.
Agatha 1619 Broadway, N.Y.C.
Age (BMI Can.)
Agean 195-40 E. Peck Fresh Meadow, N.Y.
Agnola 507 Fifth, N.Y.C.
Agon 2139 Daly, N.Y.C.
Aikens & Lafayette 438 East 93 Chicago
Aim 1776 Broadway, N.Y.C.
Airbourne 1007 17 Ave S., Nashville, Tenn.
Airefield 10859 Landale No. Hollywood, Cal.
Airwaves 1619 Broadway, N.Y.C.
Aisha, 120 E 56, N.Y.C.
Ajay 150 West 58, N.Y.C.
Ala King 3044 Taylor, Detroit, Mich.
Alameda 136 West 52, N.Y.C.
Alana 250 W 57, N.Y.C.
Alanbo Box 38550 Hollywood
Albania 6365 Selma Hollywood
Albamarle 408 W 57, N.Y.C.
Albi-Long 29 Murdock Court, Brooklyn
Aldebaran Box 1223, N.Y.C.
Aldrich 233 Pleasanton San Antonio, Texas
Alert 1650 B'way, N.Y.C.

Dick Ales R.D. 2 Geneva, Ohio
Alfonso, 364 N. Madison, Pasadena, Calif.
Alger 6201 Santa Monica Hollywood
Algonquin 1650 Broadway, N.Y.C.
Algowill 152 W. 49, N.Y.C.
Alhambra 117 W 70, N.Y.C.
Alhus 1307 1/2 Tamarind, L.A., Cal.
Alibri 93 East Alexanderine Detroit, Mich.
Alice 1465 Broadway, N.Y.C.
Alicia 143 West 68 N.Y.C.
Aljean 41-28 Case Elmhurst, N.Y.
Aljo 1501 Ridge, Phila., Pa.
Alki 3514 S. W. Manning Seattle, Wash.
Allee 2119 Dowling Houston, Texas
Allegheny 1650 Broadway, N.Y.C.
Allen Intercollegiate (see Winneton)
Thornton W. Allen (see Winneton)
N.D. Allender & Sons 216 Denrock Box 1231 Dalhart, Texas
Alley & Kirsch 1115 Bonner Houston, Texas
Alliance 545 Fifth, N.Y.C.
Allmac Route #1, Hermitage, Tenn.
Allmine, 2453 Bedford, Bklyn, N.Y.
Allrite 4718 W. Stanford Dallas, Texas
Alltec 1164 74 St., Brooklyn, N.Y.C.
Almimo 237 W 54, N.Y.C.
Almor 850 Longwood, Bronx
Alnur 129 Circle Dr, Teaneck, N.J.
A Lot of Good Things 225 W 57, N.Y.C.
Alpand Bankers Sec. Bldg. Walnut & Juniper Phila., Pa.
Alpat 217 Kearny San Fran., Cal.
Alpha Film 501 Madison, N.Y.C.
Alpha 501 Madison N.Y.C.
Alphony La Paz Hotel Palm Springs, Cal.
Alrac 639 1/2 Hudson N.Y.C.
Al-Ray 1851 Fifth, San Diego, Cal.
Alrita 18 Sunnysfield Hicksville, N.Y.
Alroy 1650 Broadway, N.Y.C.
Alsi 8831 Sunset L.A., Calif.
Alskip 1722 Washington St. Louis, Mo.
Altair 5340 S. Fairfield Chicago
Alton 157 W. 57, N.Y.C.
Altoona 75-13th Wheeling, W. Va.
Joe Altschuler 1501 Broadway, N.Y.C.
Alvin 1650 Broadway, N.Y.C.
Amano 608 Fifth, N.Y.C.
Amaran 6 Deer Trail, Old Tappan, N.J.
Amboy 168 Blake, Brooklyn, N.Y.
American Composers Alliance 2121 Broadway, N.Y.C. New York, N.Y.
American Jazz 2 W. 45, N.Y.C.
American Melodies 4318 N. Monticello, Chicago
American Metropolitan 135 W. 50, N.Y.C.
American 9109 Sunset Hollywood
American Performing Rights 1619 Broadway, N.Y.C.
Americana House 18 E. Chestnut, Chicago
Ames 134 Pinewood Teaneck, N.J.
Amestoy 39 Forest Hills Woodland Hills, Cal.
Amijo 6126 W. Belmont Chicago
Amin 400 Central Park West, N.Y.C.
Amity 37 W 57, N.Y.C.
Amor 233 E. 32, N.Y.C.
Ampar, 101 W 55, N.Y.C.

Ampen 8542 Benton Phila., Pa.
Amphora 1727 Division Davenport, Iowa
Ample 157 W. 57, N.Y.C.
Amplified P.O. Box 125, Cambridge City, Ind.
Ampolaires, 116 Virginia, Bridgeport, Conn.
Amshell 1780 Broadway, N.Y.C.
Amy 570 Fifth, N.Y.C.
Anatole (see Premier Albums)
Anbee 2135 Princeton, Bethlehem, Pa.
And 15 W. 55 N.Y.C.
Ander (BMI Can.)
Andick 846 N. Cahyenga, Hollywood, Calif.
Elizabeth Andis Morristown, Ind.
Andon 605 Crest, Manhattan Beach, Cal.
Andover 32436 Tarryton Farmington, Mich.
Andrades 6511 England, Houston, Texas
Andre 839-57th Brooklyn, N.Y.
Andy Andrews Box 136 Kent, Conn.
Annual, 2480 16 St N.W., Wash., D.C.
Anfil 1360 New York, Brooklyn, N.Y.
Angel 756 7th Ave, N.Y.C.
Angelique Wilton, Connecticut
Johnny Angle 2224 Blevedere Jackson, Miss.
Angle 117 W. 48 N.Y.C.
Angle-Anderson Box 9156 Jackson, Miss.
Anika 1359 Oak San Fran., Cal.
Animation 4949 Hollywood, Hollywood
Anita 14 W. 103rd St, N.Y.C.
Annabelle 1048 N. Carol L.A., Cal.
Annandale 1695 Clear View Beverly Hills, Cal.
Ann-Dee 1133 Broadway, N.Y.C.
Annette 1440 N. Highland Hollywood
Annis 1323 S. Michigan Chicago
Anode, 3974 McClung Dr, Los Angeles, Cal.
Another, 200 W. 57, N.Y.C.
Anthem 180 Route 17 Paramus, N.J.
Anthony 1449 S. Michigan Chicago
Anthon 7601 S. Stewart Chicago
Antilleana 160 Broadway, N.Y.C.
Antoine 565 Fifth, N.Y.C.
Antupa 9600 Harvard, L.A., Cal.
Apache 12517 Hartense, Studio City, Calif.
Apex 2775 Lantz, San Jose, Cal.
Apogee 424 S. Pearl Youngstown, O.
Applejack 200 W 57, N.Y.C.
Apprentice 640 Fifth, N.Y.C.
Apreco 2326 E. Side Johnson City, Tenn.
Arc 1619 Broadway, N.Y.C.
Arch-Tone P.O. Box 3296, Scottsdale, Arizona
Arco 13500 Shaker Blvd, Cleveland
Arctic 250 W. 57th St, N.Y.C.
Arctic 415 S. New Hampshire L.A., Cal.
Arda 186 Monroe Memphis, Tenn.
Ardle 164 Waverly, N.Y.C.
Ardleigh 4627 Morro Woodland Hills, Cal.
Ar-Do Music (BMI Can.)
A-Rex Berlin W 30, Taunentzien 16, Ger.
Argo 1055 N. El Centro L.A., Cal.
Argyle 30 W. 60 N.Y.C.
Aries 3747 Ruthelen L.A., Cal.
Aristokrat Hotel President 234 W. 48 N.Y.C.
Ariston 1733 Broadway, N.Y.C.
Arkay 5646 Lemona Van Nuys, Cal.
Ark-La-Tex 1619 Broadway, N.Y.C.
Arlington Place, 105 S. La Salle, Chicago
Armada 1650 Broadway, N.Y.C.

Armel 3343 W. Crystal, Chicago
Armo see Lois
Armond Hotel Shelton, 49th & Lexington, N.Y.C.
Joseph L. Armstrong 1268 S. Bonsall Phila., Pa.
Arness 1240 Yale, Santa Monica, Cal.
Arnett 2825 Gay L.A., Cal.
Arnold Music 850 7th Av, N.Y.C.
Arren & Broderick 4149 N. Leanington Chicago
Arrex (BMI Can.)
Arrowhead See Golden West Melodies
Arroyo 1646 Lucile, L.A. Calif. Art Audio 9706
Art 1279 Queen Anne L.A., Cal.
Cameron Ave. Detroit, Mich.
Arta 1732 Amsterdam N.Y.C.
Artemis 9151 Sunset Blvd, L.A., Cal.
Edward Arthur 135 West 50th St, N.Y.C.
Arthur 55 West 74th St, N.Y.C.
Artia 1650 Broadway, N.Y.C.
Artillery 235 W. 46 N.Y.C.
Artist Band Composer 1149 W. Santa Ana, Fresno, Cal.
Artisticque 2881 Roosevelt Ave, Bronx, N.Y.C.
Artrec Box 66 Miami, Fla.
Arree 7039 Sunset Hollywood
Asbury 79 W. Monroe Chicago
Ashland 136 E. 57th N.Y.C.
Ashna 115-B Third Ave. N. Nashville, Tenn.
Ashtown 1619 Broadway N.Y.C.
Ashwood 617 Exchange Bldg. Nashville, Tenn.
Asnes 217 125th, N.Y.C.
Assembly 8 Westervelt, Tenafly, N.J.
Associated Composers 630 Ninth Ave., N.Y.C.
Associated 1 W. 47th N.Y.C.
Aster 2415 So. Ridgeley L.A., Cal.
Robert Astor 1650 Broadway, N.Y.C.
Astro 785 De Soto Ypsilanti, Michigan
At Last 2666 Ellendale Pl, LA, Calif.
Athens 1096 Lynwood Blvd. Nashville, Tenn.
Athon 26 Benton Ave. Naperville, Illinois
Atina 392 Central Park W., N.Y.C.
Atlantic 6124 Selma Ave, Hollywood
Atna Box 1707 Div. St. Nashville, Tenn.
Atomic 14743 Saticoy, Van Nuys, Cal.
Audicon 1674 B'way, N.Y.C.
Audio-Master 17 E. 45th, N.Y.C.
August 8732 Sunset, Hollywood
Aurea 1697 Broadway, N.Y.C.
Aurelio, 782 8th Av., N.Y.C.
Aurora 614 W. 51st, N.Y.C.
Austin 6124 Selma Av Hollywood
Gene Autry 1556 North La Brea Hollywood
Frankie Avalon 1320 Vine Phila., Pa.
Avalon 6124 Selma, Hollywood
Avenue See Lois
Avon 130 W. 46th, N.Y.C.
Award 3655 Berryman L.A., Cal.
Awaye 808 N. Linden Beverly Hills, Cal.
Axis 4018 S. Lake Burbank, Cal.
(Continued on next page)

POP HITS

I NEVER WILL FORGET
Shirley Ellis — Congress

WHENEVER YOU'RE READY
Zombies — Parrot

EVERYONE'S GONE TO THE MOON
Jonathan King — Parrot



COUNTRY HITS

TIGER WOMAN
Claude King — Columbia

DIG, DIG, DIG — THERE'S NO MORE WATER IN THE WELL
Merle Kilgore — Epic

LIVIN' IN A HOUSE FULL OF LOVE
David Houston — Epic



Pop Hits and Country Hits Consistently Come From . . .

AL GALICO MUSIC CORP.

NASHVILLE
Merle Kilgore, Manager
812 16th Avenue, South
256-5565

NEW YORK
Al Gallico Music Corp.
101 West 5th Street
New York, New York
JU 2-1368

LONDON
Jimmy Phillips
Peter Mauric Music Co. LTD.
21 Denmark Street
London, England

the sounds that sell

come
consistently
from . . .

JOBETTE MUSIC

2648 W. Grand Blvd.

Detroit 8, Michigan

.....Seven Month Score for '65

..... 31 Songs on The Cash Box Top 100

ASK THE LONELY

Four Tops—Motown

BABY LOVE

Supremes—Motown

BACK IN MY ARMS AGAIN

Supremes—Motown

BOOMERANG

J. Walker & All Stars—Soul

CAN YOU JERK LIKE ME

Contours—Gordy

COME ON, DO THE JERK

Miracles—Tamla

COME SEE ABOUT ME

Supremes—Motown

HE WAS REALLY SAYING

SOMETHING

Velvelettes—V.I.P.

HOW SWEET IT IS

Marvin Gaye—Tamla

I CAN'T HELP MYSELF

Four Tops—Motown

I'LL ALWAYS LOVE YOU

Spinners—Motown

I'LL BE DOGGONE

Marvin Gaye—Tamla

I'LL KEEP HOLDING ON

Marvelettes—Tamla

IT'S GROWING

Temptations—Gordy

IT'S THE SAME OLD SONG

Four Tops—Motown

LONELY LONELY GIRL

Velvelettes—V.I.P.

MY GIRL

Temptations—Gordy

NOTHING BUT HEARTACHES

Supremes—Tamla

NOWHERE TO RUN

Martha & Vandellas—Gordy

OOO BABY BABY

Miracles—Tamla

OPERATOR

Brenda Holloway—Tamla

PRETTY LITTLE BABY

Marvin Gaye—Tamla

SHAKE & FINGERPOP

Jr. Walker & All Stars—Soul

SHOTGUN

Jr. Walker & All Stars—Soul

SINCE I LOST YOU BABY

Temptations—Gordy

STOP IN THE NAME OF LOVE

Supremes—Tamla

THE TRACKS OF MY TEARS

Miracles—Tamla

TOO MANY FISH IN THE SEA

Marvelettes—Tamla

WHEN I'M GONE

Brenda Holloway—Tamla

WILD ONE

Martha & Vandellas—Gordy

WITHOUT THE ONE YOU LOVE

Four Tops—Motown

BMI PUBLISHERS

Aye & Bee 1819 Fairmount Phila., Pa.
Azmerit, 65 E 55th St, N.Y.C.
Azure 422-18th Santa Monica, Cal.

B & B Box 7816 Detroit, Mich.
B. & F. 1322 S. Michigan Chicago
B. & S. 302 Exchange Bldg., Nashville, Tenn.
BMI Canada 16 Gould Toronto, Can.
BRC 445 Park Av. N.Y.C.
B.R.S. 50 Lenox Rd. Brooklyn
B.R.S. 527 Madison, N.Y.C.
B-W Box 337 Worcester, O.
Babb 48 & Tennessee Nashville, Tenn.
Bach 135 Nassau Atlanta, Ga.
Bachelor 430 N. Rodeo Beverly Hills, Cal.
Back Beat 211 Spruce Newark, N.J.
Backus 1270 6 Ave, N.Y.C.
Backwoods Box #301 Nashville, Tenn.
Bae N.W. Cor. 8 & Fitzwater Sts, Phila.
Baha 4811 Laurel Canyon N. Hollywood
Baileys 1448 Denman Cincinnati, O.
Bainbridge Box 1326, Seattle, Wash.
Bais 50 So. Main Memphis, Tenn.
Balare 1755 B'way, N.Y.C.
Balboa 15038 Haynes Van Nuys, Cal.
Baldwin 145 W. 45, N.Y.C.
Ball Box 246, N.Y.C.
Ballantyne (BMI Can.)

Balleran 1812 Tammany Nashville, Tenn.
Bamboo 6515 Sunset, Hollywood
Bandshell 1204 Kermit Nashville, Tenn.
Bandstand 1650 Broadway, N.Y.C.
Banff (BMI Can.)
Banham 545 Madison, N.Y.C.
Banks 1411 Walnut Phila., Pa.
Bantron, 9649 Fern Ave., El Monte, Calif.
Bar 11314 1/2 S. Main L.A., Cal.
Barabash (BMI Can.)
Barbary 4430 Santa Monica Blvd. L.A., Cal.
Barbera-Hanna 3401 Cauenga L.A., Cal.
Barbizon 2935 Fenton Bronx, N.Y.
Barclay 972 Peninsula Woodmere, N.Y.
Barcone, 150 W 55, N.Y.C.
Bardell 370 Carlton Brooklyn, N.Y.
Harry Bare 413 Race Cincinnati, O.
Barham 1229 Olive Hollywood
Bari 1700 Locust Phila., Pa.
Don Barksdale 138 Grand Oakland, Cal.
Barlou 1423 N. Havenhurst, Hollywood
Bar-Mar 2120 S. Michigan Chicago
Barnegat 1733 Broadway, N.Y.C.
Barnhart Box 284, Vienna, Ohio
Barco 4421 Grimes Pl. Encino, Calif.
Paul Barrett 709 Central Tower, San Francisco
Ron Barrett 442 E. 93rd L.A., Cal.
Barrister Box 2731 Long Beach, Cal.
Barronette 3220 Audley Houston 6, Texas
Barrow 201 W. 49th New York, N.Y.
Bessie Barry 7192 Alaska, Detroit, Mich.
Barry-Michael 200 W. 57 N.Y.C.
Bart 548 Woodward Detroit, Mich.
Earl Barton 1121 S. Glenstone, Springfield, Mo.
Bass 418 Lake Dr., Hapeville, Ga.
Batir 4050 Brick Church Pike Nashville, Tenn.
Bay (BMI Can.)
Bayberry 1730 Broadway, N.Y.C.
Baves 4233 Navajo St. N. H'wood, Calif.
Johnny Baylor 850 7 Ave, N.Y.C.
Bayou Box 115 Madison, Tenn.
Bay-Tone 1509 Fillmore San Francisco
Bayview Box 1373 Port Arthur, Texas
Bayville 170 W. 74th, N.Y.C.
Beach 149 E. 97th, N.Y.C.
Beacon 25 Beacon Boston, Mass.
Beacon Hill 150 W55, N.Y.C.
Beak 5411 Lyford Memphis, Tenn.
Beale Street Box 32014 L.A., Cal.
Beam 414 W. 44th, N.Y.C.
Beamark 3109 Mermaid, Brooklyn, N.Y.C.
Be-Are 319 Seventh Ave. N. Nashville, Tenn.
The Beat 3852 Grosvenor S. Euclid, O.
Beatnick 686 Woodlawn Memphis, Tenn.
Beaumont 4113 Dixie Canyon Sherman Oaks, Cal.
Beau-Nichols 4836 Agnesaux N. Hollywood
Beau-Tex 4965 Bruce Dr. Beaumont, Texas
Bebe 1650 Broadway, N.Y.C.
Beckie 801 Dupont Bldg Memphis, Tenn.
Beckwin 57 West 75th, N.Y.C.
Beda c/o Bess Music, N.Y.C.
Bedoc 200 W. 57th N.Y.C.
Bee Cee Dee 507 S. Westgate, L.A., Cal.
Bee Gee 616 Exchange Bldg, Nashville, Tenn.

Bee Jay 100 W. 42nd N.Y.C.
Bee 565 Fifth, N.Y.C.
Beechmont 1650 Broadway, N.Y.C.
Beechwood 1750 Vine, Hollywood
Begans 1674 B'way, N.Y.C.
Begonia 4428 Calle Allegre, Phoenix, Ariz.
Beige 1010 S. Robertson Blvd., L.A., Cal.
Be-Jax 920 Walnut St., Phila, Pa.
Bejo See Lois
Bel Aire 10 S. La Salle St., Chicago, Ill.
Bel Star Music P.O. Box 1763 Hollywood 28, Cal.
Belfry 6363 Sunset Blvd., Hollywood 28, Cal.
Belhaven 11920 S. Central, L.A., Cal.
Bellage 15 E. 48th N.Y.C.
Bellerophon 1447 N. Gower Hollywood, Cal.
Belleville 17 E. 45th St. N.Y.C.
Bell-Kaye 1619 Broadway, N.Y.C.
Bell-Tone 36 W. 44th N.Y.C.
Belmar 565 West End Ave., N.Y.C.
Belmont 823 S. Wabash Chicago, Ill.
Belroy 56 W. 45th N.Y.C.
Ben Hue 241 W. Florence L.A., Cal.
Benbe 1762 W. 36th L.A., Cal.
Benbolt 565 Fifth, N.Y.C.
Benday 345 W. 58th N.Y.C.
Bendig 10 Columbus Circle, N.Y.C.
Beneficial 9151 Sunset Blvd. Hollywood, Cal.
Benell 315 W. 47th St. N.Y.C.
Bengal 2648 W. Grand Detroit, Mich.
Ben-Ghazi 515 Madison Ave., N.Y.C.
Bengo 250 East 4th N.Y.C.
Ben-Lee 15th And Market Phila, Pa.
Benmax 12202 Herbert L.A., Cal.
Ben-Meyer 1595 Broadway, N.Y.C.
Bob Bennett 1600 Chancellor St., Phila. 3, Pa.
Benral 320 W. 76th, N.Y.C.
Benson 11956 Riverside Dr., N. Hollywood, Cal.
Benton 1010 S. Robertson Blvd., L.A., Cal.
Benway 11815 Magnolia #1 N. Hollywood, Cal.
E.M. 6117 Liebig Ave., N.Y.C.
Bercon 6223 Selma Hollywood, Cal.
Berkely 1650 Broadway N.Y.C.
Berkshire 756 Seventh N.Y.C.
Bernardo Belmont Plaza Lexington & 49th St. N.Y.C.
Bernwood 1650 Broadway, N.Y.C.
Berry 630 Fifth, N.Y.C.
Bertgil 229 Park Ave. S. N.Y.C.
Bertuccini 6221 Grays Phila, Pa.
Beta 242 North Canon Dr. Beverly Hills, Cal.
Betabin 729 Seventh Ave. N.Y.C.
Bette 200 W. 49th N.Y.C.
Bettina 222 W. Rittenhouse Phila. Pa.
Bibo 1619 Broadway, N.Y.C.
Biernat & Dietz 19600 Rogge Ave. Detroit 34, Mich.
Big Bonper Box 849 Beaumont, Texas
Big Chief 618 Stahlman Bldg. Nashville 3, Tenn.
Big "D" Music, Sportatorium, Dallas, Texas
Big Jay Swings 2127 E. 110th St. L.A., Cal.
Big Pack 37 W. 57th N.Y.C.
Big Seven 1341 Broadway, N.Y.C.
Big Star 4432 Prairie Chicago, Ill.
Bigtop 1619 B'way, N.Y.C.
Big Wedge Music 3101 Fleet St. Baltimore, Md.
Big World 4601 Afton Dallas, Texas
Bigareff 10 Columbus Circle, N.Y.C.
Big-Ben Box 1571 San Francisco, Cal.
Big Mack 12867 Livernoise, Detroit
Billen 530 Carlton House Pittsburgh, Pa.
Billie Fran 5219 Madella, Ft. Worth, Texas
Billy, Jr. 1573 Sunset Plaza Dr. L.A., Cal.
Bilya-Bah 130 South Breed L.A., Cal.
Bimbo 5627 Klump Ave. N. Hollywood, Cal.
Bingo 1774 North La Brea Hollywood, Cal.
Birchdale 3007 Birchdale Dr. Memphis, Tenn.
Birdsong 592 Farnsworth Detroit, Mich.
Bishop 1650 Broadway, N.Y.C.
Bittersweet, 70 Winding Wood Rd, South, Port Chester, N.Y.
Blackburn 931 Alfred, L.A., Cal.
Blackhawk 1800 N. Argyle Hollywood, Cal.
Black Rabbit, 2221 W. Olive, Burbank, Cal.
Blackthorn 7667 Fountain Hollywood, Cal.
Blacron 10323 Santa Monica Blvd. L.A., Cal.
Blair's 1906 Clemente, Detroit, Mich.
Blanchard 1570 N. Gower Hollywood, Cal.
Blane 949 No. Beverly Dr. Beverly Hills, Cal.
Blanton 18459 Ryan Rd., Detroit, Mich.
Blazon Box 35, Nashville, Tenn.
Blecker 319 E. 8th St. N.Y.C.
Blend 252 W. 149th St. N.Y.C.
Bloor 1549 N. Vine Hollywood, Cal.
Blue Bird 32 Falmouth St., Boston, Mass.
Blue Grass 157 W. 57th N.Y.C.
Blue Indigo 3330 Barham Blvd. Hollywood, Cal.
Blue Ridge 1540 Brewster, Cincinnati, O.
Blue River 6223 Selma Hollywood 28, Cal.
Blues Beat Box 464, N.Y.C.
Bluff City 157 W. 57th N.Y.C.
Bob & Jerry c/o Bob Feldman 165 End Ave., Brooklyn 35, N.Y.
Boban 120 W. 57th N.Y.C.
Bobber 4837 Mitchell Detroit, Mich.
Bobby 1650 Broadway, N.Y.C.
Bob-Dan 271 125th N.Y.C.
Boblo 2056 Calvert Detroit, Mich.
Bobrich 39 W. 60th N.Y.C.
Bobwhite 6046 H'wood Blvd H'wood, Cal.
Bodean 6720 S.W. 57th Terrace Miami, Fla.
Boelsen, 608 Fifth Ave. N.Y.C.
Boka 1631 Broadway, N.Y.C.
J. J. Bolen 1060 Crenshaw Blvd., L.A., Cal.
Bolens 1405 E. Sixth St. Cleveland, O.
Bolmin 1236-19th Ave., East Seattle, Wash.
Bon Bon 59 Monroe St., Chicago, Ill.
Bonatemp 1810 Dryades New Orleans, La.
Bonnie Dee 920 8rd Ave Seattle, Wash.
Booker Ervin 430 W. Broadway, N.Y.C.
Boras 1619 Broadway, N.Y.C.
Bortoli 217 E. 115th St., Chicago, Ill.
Boss 25 Somerset Newark, N.J.
Bostill 3705 Palm Street St. Louis, Mo.
Boulevard 46 E. Walton St., Chicago, Ill.
Bourbon Street 2939 Serantine New Orleans, La.
Boxer Music Co. c/o Blair House 445 N. Rossmore Ave. Hollywood 4, Cal.
Boylston 1 Boylston Pl. Boston, Mass.
Bradley 1433 Citadel Dr. N.E., Atlanta, Ga.
Brad-Mar 6700 Laurel Grove, No. Hollywood, Cal.
Brakenbury 1619 Broadway, N.Y.C.
Bramble 913 17 Ave S., Nashville, Tenn.
Bramco 6410 Madison Rd., Cincinnati, O.
Brand 2 West 45th St., N.Y.C.
Branix 710 Burdette, New Orleans, La.

Branna 6087 Sunset, Hollywood, Cal.
Branston 56 W 45, N.Y.C.
Branwin 1619 Broadway, N.Y.C.
Brasiero 2 W. 45th St., N.Y.C.
Bre-Ho 408 W. 57th, N.Y.C.
Brenda 1501 Broadway, N.Y.C.
Bren-Lue Box 18882, Los Angeles, Cal.
Brenner 1619 Broadway, N.Y.C.
Brent 2 W. 45th, N.Y.C.
Brentwood 3650 Watsaka, L.A., Cal.
Bresnahan 6606 Sunset, Hollywood, Cal.
Brewster 745 Fifth, N.Y.C.
Brianbert 4862 Parker St. Detroit
Briarcliff 6365 Selma, Hollywood, Cal.
Bric 801 16 Ave S., Nashville, Tenn.
Bright Star 605 W. 156 St., N.Y.C.
Bright-Tunes Brooklyn 17, N.Y.
Brilliant 1438 N. Gower, Hollywood, Cal.
Brindise 2500 N. Campbell, Chicago, Ill.
Brio 6515 Sunset Blvd., Hollywood, Cal.
Brittany 1619 Broadway, N.Y.C.
Britton 1440 Broadway, N.Y.C.
Broadset 1650 Broadway, N.Y.C.
Broadstreet 1616 Western Sav. Fund Bldg., Broad & Chestnut St., Phila., Pa.
Brockman-Schenck 1650 Broadway, N.Y.C.
Brohun 437 Wilkins, Detroit, Mich.
Brompton 50 Central Park W., N.Y.C.
Bronjo Music Publishing Company, Inc. 39 West 60th St., New York 23, N.Y.
Brookdale 756 Seventh Ave., N.Y.C.
Brookville 345 W. 58th, N.Y.C.
Alexander Brovide, 120 W. 57th, N.Y.C.
Brown and Crane 15113 St. Clair Cleveland, O.
Brown & Green 9022 12th, Detroit, Mich.
Brown 1650 Broadway, N.Y.C.
Robert B. Brown 2320 Stanley Hills Dr., Hollywood, Cal.
T. Brown & Sons 253 Merritts Ave., Atlanta, Ga.
Brown-Regan 6356 De Longpre, Hollywood, Cal.
Brownstone 417 E. 50th St., N.Y.C.
Brownwood 1631 Broadway, N.Y.C.
Bruder 625 Madison Ave., N.Y.C.
Bruin 322 W. 48th, N.Y.C.
Bruno & Son 1650 Broadway, N.Y.C.
Brunswick 2334 S. Holt, L.A., Cal.
Bryant House 3040 S. La Brea, L.A., Cal.
Bryden 157 W. 57th St., N.Y.C.
Brynor 392 Central Park W., N.Y.C.
Al Bubis 8462 Sunset Blvd., L.A., Cal.
Buckeye 204 W. 8th St., Cincinnati, O.
Buckhorn 1309 Hildreth Nashville, Tenn.
Buddy 135 W. 125th St., N.Y.C.
Budor P.O. Box 1385, Beverly Hills, Cal.
Bugle Boy 185 N. Wabash, Chicago, Ill.
Bumarack 1023 N. 67th, Phila., Pa.
Buna 1707 Division, Nashville, Tenn.
Bundle 1650 B'way, N.Y.C.
Burden 201 W. 49th, N.Y.C.
Burdette 6515 Sunset Blvd., Hollywood, Cal.
Burdette 2227 5 Ave, Seattle, Wash.
Burke-Fader 6727 First Ave, South, St. Petersburg, Fla.
Johnny Burnette 6223 Selma, Hollywood, Cal.
Burrows 284 Newbury, Boston, Mass.
Busim 1422 E. 43 St., L.A., Cal.
Buttercup 2817 Vanderbilt, Nashville, Tenn.
Buttons 4922 Santa Monica, Hollywood, Cal.
By-Nash 115 1/2 Third Ave., N. Nashville, Tenn.
Ethel Byrd 205 W. 84th, N.Y.C.
Byron 8330 W. Third, L.A., Cal.

Entertainment At Its Best is on

JAY
JAY



and
**DRUM
BOY
Records**

Jay Jay Records Features America's No. 1 Polka Band, Lil Wally plus many other polka artists and the

New! Exciting! Jagiello Sound
Write for Free Catalog
JAY JAY—DRUM BOY RECORD CO.
2454 S. Kedzie Ave., Chicago 23, Ill.
Phone: 762-6000

Some great copyrights...

- "Blue Velvet"
- "Canadian Sunset"
- "Apples & Bananas"
- "Schatzie"
- "I Want A Girl"
- "When My Baby Smiles At Me"
- "Row Row Row"
- "Blue Christmas"
- "Shutters and Boards"
- "Turn Back The Hands of Time"
- "You're The Reason"
- "Ko Ko Mo"
- "Pistol Packin' Mama"

...and many others

Music Publishing Division

TELEKLEW PRODUCTIONS, INC.

New York Office
Frank Abramson
1619 Broadway
New York, N.Y. 10019
Lt-1-3197

California Office
Paul Weirick
2444 Wilshire Blvd.
Santa Monica, Calif.
Upton 0-7076

C And D 200 W. 57th, N.Y.C.
C. B. 1631 Broadway, N.Y.C.
CCC 8136 Wortsner N. Hollywood, Cal.
C-11 9003 Dayton Way, Beverly Hills, Cal.
C. J. 4803 S. Indiana, Chicago, Ill.
Cable 744 Broad, Newark, N.J.
Cactus Box 8626, L.A., Cal.
Cadet 5757 Franklin, Hollywood, Cal.
Cafe 1022 N. Croft, L.A., Cal.
Cajun Box 1387, Shreveport, La.
Cal 514 Franklin, Nashville, Tenn.
Calaban 7966 Beverly Blvd., L.A., Cal.
Calabar 4779 Whittier Blvd., L.A., Cal.
Calcagno 106 Southard Ave. Rockville Center, N. Y.
Caldwell 2034 Ridge, Phila., Pa.
Cal-Lee 3839 Sawtelle Blvd., L.A., Cal.
Calliope 75 E. 55th, N.Y.C.
Calumet 823 S. Wabash, Chicago
Calvin 2 W. 45th, N.Y.C.
Calyork 119 W. 57th, N.Y.C.
Camarillo 6087 Sunset Blvd., Hollywood, Cal.
Cambria 5224 Teesdale, N. Hollywood, Cal.
Cambridge 565 Fifth, N.Y.C.
Camden 6087 Sunset, Hollywood
Camel 1697 Broadway, N.Y.C.
Cameo-Parkway 1405 Locust, Phila.
Camera 540 W. 123rd, N.Y.C.
Camille 11314 1/2 S. Main, L.A., Cal.
Camino 8321 Beverly Blvd. Los Angeles
Camp And Canyon 1616 N. Argyle, Hollywood
Camrick 156 W. 44th, N.Y.C.
Cana 1707 Division, Nashville, Tenn.
Canard 1710 North La Brea, Hollywood
Candid 110 MacDougal, N.Y.C.
Candle-Glo 1124 Bennie Dillon Bldg., Nashville, Tenn.
Candle-Light 4177 4th Ave., L.A., Cal.
Canford 1619 Broadway N.Y.C.
Canjoco 511 Troy Drive, San Jose 28, Cal.
Cannon Point 1841 Broadway, N.Y.C.
Cannon 9837 Tabor, L.A., Cal.
Cannon 222 Rittenhouse Sq W., Phila., Pa.
Canoga 20955 Elkwood, Canoga Pk., Cal.
Cantata 235 W. 46th, N.Y.C.
Canterbury 344 S. Serrano, L.A., Cal.
Cantina 73 Newbury, Boston, Mass.
Canuck 6605 Hollywood Blvd., Hollywood, Cal.
Canyon 1501 Broadway, N.Y.C.
Cape Ann 801 17th Ave. S., Nashville, Tenn.
Capesana 2136 Laurel Canyon Blvd., Hollywood
Capitol City Box 8061 Nashville, Tenn.
Capizzi 618 S. Glenwood Pl., Burbank, Cal.
Capri 145 W. 45th St., N.Y.C.
Caprice 1104 N. Military, Detroit 9, Mich.
Capricorn 1031 N. Lima St., Burbank, Cal.
Car-Ano 10558 Lauriston Ave., W. Los Angeles, Cal.
Cardinal 1587 Broadway, N.Y.C.
Car-Gor 2207 N. Broad St., Phila, Pa.
Carlott 6758 Colgate, L.A., Cal.
Carlson 413 Race, Cincinnati, O.
(Continued on next page)



Thank you from the Family at Tree

TREE PUBLISHING CO.

(Exclusive Writers)

ROGER MILLER
DOTTIE WEST
JOE TEX
JOHN HURLEY
RONNIE WILKINS
DON WAYNE
CHRISTY ALLEN
BILL WEST
BOBBY MARCHAN
BOBBY BOND
JUSTIN TUBB
BILL CATES
CURLEY PUTMAN
JEAN CHAPEL
RED LANE
BILL MOORE
LARRY BUTLER
LARRY BARNES
BUDDY KILLEN
HOBAY DODD
EDDIE BENTLEY
SANDRA RHODES
KENDALL HAYES

DIAL RECORDS

(Incorporated Artists)

JOE TEX
BOBBY MARCHAN
JACK BARLOW
WAYNE KEMP
HOBAY DODD
THE ILLUSIONS
CLARENCE REID
THE RHODES SISTERS
JERRY WOODARD
STAN BEAVER
MARTY MARTELL
CHIPS MOMAN

SOME OF TREE'S 1965 HITS

KING OF THE ROAD
HOLD WHAT YOU'VE GOT
I LOVE COUNTRY MUSIC
YAKETY AXE
ONE DYIN' AND A BURYIN'
ENGINE, ENGINE
NUMBER NINE
WILD AS A WILDCAT
QUEEN OF THE HOUSE
GREEN GREEN GRASS
OF HOME
A WOMAN (CAN CHANGE
A MAN)
YOU GOT WHAT IT TAKES
ONE MONKEY DON'T STOP
NO SHOW
BELLES OF SOUTHERN BELL
BUILD YOUR LOVE
(ON A SOLID FOUNDATION)
BEERS AND TEARS
DO-WACKA-DO
YOU BETTER GET IT
IT HAPPENED JUST
THAT WAY

Congratulations
to the
TREE WRITERS
for winning
all of the
1964
(NARAS)
GRAMMY
AWARDS
in the
COUNTRY MUSIC
CATEGORY

Jack Stapp
president
W. D. (Buddy) Killen
exec. v.p.



TREE PUBLISHING CO. INC.

905 Sixteenth Ave., South
Nashville, Tennessee
represented internationally by BURLINGTON MUSIC

BMI PUBLISHERS

Carmel c/o Stanley Goldstein 122 E. 42nd St., N.Y.C.
 Carnegie 60 W. 68th, N.Y.C.
 Carney 2203 Spruce, Phila., Pa.
 Carolintone 1040 N. Las Palmas, Hollywood
 Carolyn 506 E. 35th, L.A., Cal.
 Ed Carrell 7123 Vivian, Dallas, Texas
 Carrowtown 6605 Hollywood Blvd., Hollywood
 Carsey 1560 N. La Brea, Hollywood
 Carson-Carrier 1608 N. Central, Knoxville, Tenn.
 Carte 6515 Sunset, Hollywood
 Carter 6000 Sunset, Hollywood
 Cascade 333 Sixth, N.Y.C.
 Johnny Cash 1619 Broadway, N.Y.C.
 Castle 6087 Sunset Blvd., Hollywood
 Catalina 1650 Broadway, N.Y.C.
 Cathy 9500 Goebel, L.A., Cal.
 Cattleman 200 W. 57th St, N.Y.C.
 Causeway 1441 Broadway, N.Y.C.
 Cave 817 16 Ave S., Nashville, Tenn.
 Cedarlane 818 Kendall Drive, Nashville, Tenn.
 Cedarwood 815 16th Ave. S., Nashville, Tenn.
 Cece 1318 Poplar, Memphis, Tenn.
 Celann, 119 N. 9th, Minneapolis, Minn.
 Celebrity 6758 Colgate, L.A., Cal.
 Celebs 8848 Sunset, Hollywood
 Celeste 13209 Southview, Cleveland, O.
 Centella 6425 Hollywood Blvd., Hollywood
 Central 1483 N. Vine, Hollywood
 Century Songs 1483 N. Vine, Hollywood
 Ceola 510 N. 34th, Phila., Pa.
 Cepha 2146 West View, L.A., Cal.
 Cevet 130 Newark, Jersey City, N.J.
 Chador 4512 Chouteau, St. Louis, Mo.
 Challenge 157 57th, N.Y.C.
 Cham 565 Fifth, N.Y.C.
 Champion 445 Park, N.Y.C.
 Champlain 836 E. 63rd, Chicago, Ill.
 Chance 4324 Fourth, L.A., Cal.
 Chancel 1151 S. Broadway, L.A., Cal.
 Chandler 252 Main, Ansonia, Conn.
 Chant 11358 Asbury Park, Detroit, Mich.
 Chantez 10 Columbus Circle, N.Y.C.
 Chanto 1608 N. Argyle, Hollywood, Cal.
 Charlwood 1650 B'way, N.Y.C.
 Charchris 11937 Strathern, Hollywood, Cal.
 Charill 4461 Fulton, Sherman Oaks, Cal.
 Chariot 14 Main, Monsey, N.Y.
 Charlek 235 Brooklyn, Brooklyn, N.Y.
 Charles 77 Crown, Milton 87, Mass.
 Charlene 433 Vista Drive, Falls Church, Va.
 Charles Bell 923 Adelaide, Pittsburgh 19, Pa.
 Charles Street 22 Charles N.Y.C.
 Charles 450 W. 24th, N.Y.C.
 Charlotte 307 E. 44th, N.Y.C.
 Charm 1619 Broad., N.Y.C.
 *Charran 7 Moreland, Roxbury, Mass.
 Charrich 545 Fifth, N.Y.C.
 Chart 1520 Archer Road, Bronx 62, N.Y.
 Chartbuster 1745 K St. N.W. Wash., D.C.
 Chas-Bon 3519 Kendrick Memphis, Tenn.
 Chase 8501 Remick, Sun Valley, Cal.
 Chateau 200 W. 57th, N.Y.C.

Chat-Tone 6538 S. Evans, Chicago, Ill.
 Chaz-Mar 331 W. 51st, N.Y.C.
 Frederick C. Cheatham 1108 N. 27, Richmond, Va.
 Check Mark 1615 Bren Mar Drive, Alexandria, Va.
 Check 50 West 77th, N.Y.C.
 Check-Colt 1405 Locust, Phila., Pa.
 Checker 155 E. 76th, N.Y.C.
 Cheers 404 N. Roxbury Dr., Beverly Hills, Cal.
 Chelsea 1650 Broadway, N.Y.C.
 Cheltenham 212 N. 12th, Phila., Pa.
 Chelwood 48 W. 48th, N.Y.C.
 Chemistry 6330 Lindenhurst, L.A., Cal.
 Chenar 2914 N. Cicero, Chicago, Ill.
 Cherie 3621 Heath Lane, Mesquite, Texas
 Cherie 400 Madison, N.Y.C.
 Cher-Lo 701 Seventh, N.Y.C.
 Cherritown 1607 El Centro, Hollywood, Cal.
 Cherry Hill 6 Darby Lane, Cherry Hill, N.J.
 Cherry Valley 1302 Sigel, Phila., Pa.
 Jack Chertok Television 780 N. Gower St. Los Angeles
 *Chervalin 1538 Senate, New Orleans, La.
 Cheryl 305 E. Mount Eden, Bronx 57, N.Y.
 David Cheskin 209 Sterling, Buffalo 16, N.Y.
 Albert Chesrow, 35 W. Jackson Blvd., Chicago
 Chevris 2120 S. Michigan, Chicago
 Chez 31 W. 71st, N.Y.C.
 Chicago Lake Villa, Ill.
 Chickadee 1912 Western, S. Greensburg, Pa.
 Chickasaw Music, Inc. P.O. Box 8332 Cross-town Station, Memphis, Tenn.
 Chicory 250 W 57, N.Y.C.
 Chicory 222 Rittenhouse Sq. W., Phila., Pa.
 Chontay 35 Ronald, Hicksville, N.Y.
 Chords Music Publishers, 160 W. 46th St., N.Y.C.
 Chrissy 1697 B'way, N.Y.C.
 Chrismarc 1261 N. Crescent Hgts, Hollywood
 Chuck Wagon 730 Fifth, N.Y.C.
 Chuckaluck 324 S. Beverly Dr., Beverly Hills, Cal.
 Chu-Fin 1808 West End Bldg., Nashville, Tenn.
 Edwin T. Church 8029 Willon Glen Rd., Hollywood
 Cigma Box 1202 Nashville, Tenn.
 Cimarron 206 W. Walnut, Rogers, Ark.
 Cindy 1650 Broadway, N.Y.C.
 Cini 206 S. 13th, Phila., Pa.
 Cineco 855 Treat, San Francisco
 Citadel 8731 Sunset, Hollywood
 City, 157 W. 57th, N.Y.C.
 Claiborne 4000 Montpelier Rd, Manor Club, Rockville, N.Y.
 Clairwell 7319 S. Vernon, Chicago
 Clamike 850 Seventh Ave, N.Y.C.
 Clarama 200 W. 57th, N.Y.C.
 Claridge 1841 Broadway, N.Y.C.
 Cordiality Box 66591 Houston 6, Texas
 Clarose 1475 Broadway, N.Y.C.
 Clasky 1510 S. Edris Drive, L.A., Cal.
 Class 5707 Tenth, L.A., Cal.
 Classic 521 Ave, N.Y.C.
 Clayton 12020 Hoffman, Studio City, Cal.

Clef 1028 N. Western, Hollywood
 Jack Clement 639 Madison, Memphis, Tenn.
 Clifton 2 W. 45th, N.Y.C.
 Climax 113 W. 57th, N.Y.C.
 Clipper 500 Chesterfield, Nashville, Tenn.
 Clock 946 W. Agarita, San Antonio, Texas
 Clover 12020 Hoffman St., Studio City, Cal.
 Clover 27 Spring, Elizabeth, N.J.
 Clydene 726 16 Ave S Nashville, Tenn.
 Coda 19300 Ormiston, Cleveland, O.
 Coed 1619 Broadway, N.Y.C.
 Colby 250 E. 51st, N.Y.C.
 Colca 7601 S. Stewart, Chicago
 M. M. Cole, 823 S. Wabash, Chicago
 Coleman-Secon 200 W. 57th, N.Y.C.
 Colfranc 16 W 61, N.Y.C.
 Coliseum 1619 Broadway, N.Y.C.
 Collins 1631 Broadway, N.Y.C.
 Collwill 1819 Broadway, N.Y.C.
 Colo 7515 W. Irving Park Road, Chicago
 Colonial, 163 W. 23rd, N.Y.C.
 Colortunes 1041 N. Las Palmas, Hollywood
 Colpert 1650 Broadway, N.Y.C.
 Columbia Music 799 Seventh, N.Y.C.
 Column 150 W. 55th, N.Y.C.
 Combo 506 N. Virgil Ave., L.A., Cal.
 Comma 18492 Indian, Detroit, Mich.
 Command 36 W. 44th St., N.Y.C.
 Commercial 565 Fifth, N.Y.C.
 Concord 370 W. 35th, N.Y.C.
 Condado 5812 Lemp, N. Hollywood
 Congo 9523 S. Prairie, Chicago
 Conley 1841 Broadway, N.Y.C.
 Conmar 420-A Broadway, Nashville, Tenn.
 Congressional 474 Ena Rd., Honolulu
 Commuse 1750 N. Vine, Hollywood
 Mike Conner 1048 N. Carol, L.A., Cal.
 Conrad 1449 S. Michigan, Chicago
 Conroy 155 W. 46th, N.Y.C.
 Constant 756 Seventh, N.Y.C.
 Constellation 1619 Broadway, N.Y.C.
 Conte 710 N. Maple Dr. Beverly Hills, Cal.
 Contempo 50 W. 57th, N.Y.C.
 Contemporary 8481 Melrose, L.A., Cal.
 Continent 1651 Cosmo St., Hollywood
 Continental 500 Fifth, N.Y.C.
 Contur 150 W. 55th, N.Y.C.
 Con-Trans 1650 Broadway, N.Y.C.
 Contrast 11351 Burnham, L.A., Cal.
 Cooga, 9033 Wilshire, Beverly Hills, Cal., 205 West End, N.Y.C.
 Cool 1323 S. Michigan, Chicago
 Co-Op Box 631, Elizabeth, N.Y.
 Cooperative 21 W. Illinois St., Chicago
 Co-Ordinated 160 W. 46th, N.Y.C.
 Copar-Forrest, 1619 Broadway, N.Y.C.
 Copley 1 Court, Boston, Mass.
 Cord 2403 Hubbard, Brooklyn, N.Y.
 Cordia 54 W. Randolph St., Chicago
 Cordial 1926 N. St. Andrews Pl., Hollywood
 Corelli-Jacobs 723 Seventh, N.Y.C.
 Corette Box 4222, Houston, Texas
 Corinthian 1697 Broadway, N.Y.C.
 Cornball 1650 Broadway, N.Y.C.
 Cornerstone 6920 Sunset Blvd., L.A., Cal.
 Corona 1650 Broadway, N.Y.C.
 Coronation 1619 Broadway, N.Y.C.
 Cory-Richard 119 W 57, N.Y.C.
 Cotillion 1841 Broadway, N.Y.C.
 Cotter 6201 Santa Monica, Hollywood
 Countessa 409 S. Alameda Ave., L.A., Cal.
 Country, 20 E. Jackson Blvd., Chicago
 Country 2 West 45th, N.Y.C.
 Country Gentlemen 1631 B'way, N.Y.C.
 Courien 119 W. 57th, N.Y.C.
 Craft 1650 Broadway, N.Y.C.
 Cragsmoor 1472 Broadway, N.Y.C.
 Cramart 1609 Hawkins, Nashville, Tenn.
 Crane 1826 Jewett Drive, L.A., Cal.
 Cranford 356 W. 40th N.Y.C.
 Cranstone 4548 Irvine N. Hollywood, Cal.
 Cravat 6124 Selma Ave, Hollywood
 Creation 638 N. Westmount, Hollywood
 Crep 1697 Broadway, N.Y.C.
 Crestline 1587 Broadway, N.Y.C.
 Crestwood 1650 Broadway, N.Y.C.
 Cricket 9110 Sunset, L.A., Cal.
 Criss Cross 659 Tenth, N.Y.C.
 Criss 2680 Rochester, Detroit, Mich.
 Crisstan 5215 De Longpre, Hollywood
 Cristobell Carlton House Hotel, Pittsburgh
 Al Crocker 1817 Brownell, Kansas City, Mo.
 Cross Country 1014 Ellsworth St., Phila., Pa.
 Crossbow 235 Madison, N.Y.C.
 Crossroads 56 Ferry, Newark, N.Y.
 Crosstown 157 W. 57th, N.Y.C.
 Crow 100 S. Van Ness, L.A., Cal.
 Crystal 1719 Poplar Memphis, Tenn.
 Cuban 1733 Broadway, N.Y.C.
 Cupid 1152 S. Hobart, L.A., Cal.
 Curtain (BMI Canada)
 Curtom 2203 Spruce, Phila., Pa.
 Cynthia 1631 Broadway, N.Y.C.
 Cyril 200 W. 57th, N.Y.C.

De Vorzon 1606 N. Argyle, Hollywood
 Deal 701 Seventh, N.Y.C.
 Dearborn 54 W. Randolph, Chicago
 Debrossard, 856 E. 95 St, Cleveland
 December 1697 Broadway, N.Y.C.
 Decker 4123 Cole, Dallas, Texas
 Dee Dee 318 78th, N.Y.C.
 Dee 31 N. 13th, Allentown, Pa.
 Deejay 227½ S. Glenwood Pl., Burbank, Cal.
 Dee-La-Rue Corp. 1441 Broadway, N.Y.C.
 Deep South Box 342, Birmingham, Ala.
 Degree 2580 West Pico, L.A., Cal.
 Deauville 1650 Broadway, N.Y.C.
 Deb 360 N. Michigan, Chicago
 Deb-Ann 4041 N. 12th St., Phila., Pa.
 Debin 315 W. 57th, N.Y.C.
 Debra 4625 N. 50th Drive, Phoenix, Ariz.
 Debron 1619 Broadway, N.Y.C.
 Debutante 833 N. Cole, Hollywood
 Deland 9110 Sunset Blvd., L.A., Cal.
 Delanieur 2106 Fifth, L.A., Cal.
 Delhi 124 E. 4th, Cincinnati, O.
 Delilah 6087 Sunset Blvd H'wood, Cal.
 Delisse Publishing 514 Second Ave. So., Nash-ville
 Delmar 8339 Loomis, Chicago
 Delstone 1721 Broadway, N.Y.C.
 Deluxe 3103 S. Delton, L.A., Cal.
 Demar 1674 Broadway, N.Y.C.
 Demeter 128 E. 41st, N.Y.C.
 Den 930 F Street, N.W., Washington, D.C.
 Dennis 2435 South Reese, Phila., Pa.
 Densue 5539 Sunset, Hollywood
 Derry 240 Stockton, San Francisco
 Desert Palms 3703 N. 7th St., Phoenix, Ariz.
 De-Shaf 2615 Nebraska, Detroit, Mich.
 Desiard 250 W. 57th, N.Y.C.
 Desmond 240 Stockton San Francisco
 Devereaux 408 W. 57th, N.Y.C.
 Devon 10 Columbus Circle, N.Y.C.
 Devonshire 7000 Alcovine, N. Hollywood
 Dew 2020 Ridge, Phila., Pa.
 Al Dexter General Delivery, Denton, Texas
 Diadem 1619 Broadway, N.Y.C.
 Diane 6223 Selma, Hollywood
 Diary 166 Dreger Road, Memphis, Tenn.
 Harold H. Dickinson 490 San Vincente Blvd., L.A., Cal.
 Diddy Bop 427 Laurens St. Balt.
 Diedre 951 E. 47th, Chicago
 Dig 2077 S. Harvard Blvd., L.A., Cal.
 Dijon 1416 N. La Brea, L.A., Cal.
 Dinah 1631 Broadway, N.Y.C.
 Dinero 1535 N. Serrano, Hollywood
 Ding Dong 1619 Broadway, N.Y.C.
 Dinny 1619 Broadway, N.Y.C.
 Dino 526 W. Lehigh, Phila., Pa.
 Diplomacy 9229 Sunset Blvd., L.A., Cal.
 Discovery 203 N. Wabash Ave., Chicago, Ill.
 Disk 42 E. 19th, N.Y.C.
 Distant 7514 H'wood Blvd., H'wood, Calif.
 Diva 165 E. Erie, Chicago
 Dixiana 888 Pearl St., Beaumont, Texas
 Dixsil 6425 Hollywood Blvd., Hollywood
 Docir 1650 Broadway, N.Y.C.
 Dofield 345 W. 58th, N.Y.C.
 Dollar 333 E. 34th, N.Y.C.
 Dolly Bee 1951 Holmbly, L.A., Cal.
 Dolly, 203 W. 81st, N.Y.C.
 Domain 630 Fifth Av, N.Y.C.
 Dome 1959 Broadway, N.Y.C.
 Don Carlos 2534 West Pico, L.A., Cal.
 Don 2809 Erastus, Houston, Texas
 Don-Del 54 Randolph, Chicago, Ill.
 Donlou 55 East 93rd St, N.Y.C.
 Don-Michael 780 N. Gower, Hollywood, Cal.
 Donna-Joan 101 W. 55th, N.Y.C.
 Donnawell 6124 Selma H'wood, Cal.
 Ral Donner 3322 W. Peterson, Chicago
 Donnymack 2636 S. Michigan, Chicago
 Donrey Box 359, N.Y.C.
 Don-Rob 1842 S. May, Chicago
 Doo Da 135 N. Wabash, Chicago
 Peter Doraine 3431 N.W. 169th Terrace, Opalocka, Fla.
 Doral 14132 Runnymede, Van Nuys, Cal.
 Dorcas 6113 Dorcas Pl., L.A., Cal.
 Dorchester 756 Seventh Ave., N.Y.C.
 Dored 1875 S. Beverly Glen, L.A., Cal.
 Doree, Johnny & Bill 12132 Heshy N. Holly-wood, Cal.
 Dorick 101 55th, N.Y.C.
 Lee Dorman 221 Ridgefield, Nashville
 Dornie 61 Broadway, N.Y.C.
 Dornix 1540 Brewster Cincinnati, O.
 D'oro 800 8th Ave., N.Y.C.
 Dorothy 240 W. 55th, N.Y.C.
 Dorron Box 66134 L.A., Cal.
 Dot 3581 Milwaukee Chicago
 Dot 1206 Sudokum Bldg. Nashville, Tenn.
 Double O Box 1053, Beverly Hills, Cal.
 Douglas 1619 B'way, N.Y.C.
 Dougal 41 Central Park W., N.Y.C.
 Douglas & Collins 2033 Seventh Ave., N.Y.C.
 Dow 134 W. 87th, N.Y.C.
 Down South Lyle Lane, Nashville, Tenn.
 Downey 13117 Lakewood Downey, Cal.
 Doyle 1281 Monterey Ave., Berkeley, Cal.
 Draga 251 Fayette Ave. Buffalo 23, N.Y.
 Dragonwyck 2214 No. Canyon Hollywood, Cal.
 Drama 1650 Broadway, N.Y.C.
 Draper 724 W. Oakdale Chicago, Ill.
 Dreamland 40 W. 57th, N.Y.C.
 Dresden 25 C.P.W., N.Y.C.
 DREW 6025 Washington Phila., Pa.
 Drexall 2 W. 45th St., N.Y.C.
 Drive-In 7120 Sunset Hollywood, Cal.
 Druid P.O. Box 62 Atlanta, Ga.
 Drumadown 4610 Kester Sherman Oaks, Cal.
 Drummond 3766 Woodward Detroit, Mich.
 Drury Lane 1619 Broadway, N.Y.C.
 Duane Box 174 Albany, Calif.
 Duarte 1432 E. Huntington Duarte, Cal.
 Dub 1270 Sixth Ave., N.Y.C.
 Duharry 119 W. 57th, N.Y.C.
 Ducan 217 W. 25th, N.Y.C.
 Duchess 322 W. 48th, N.Y.C.
 Duceyes 235 W. 46th St., N.Y.C.
 Du-Faye 756 Seventh Ave., N.Y.C.
 Dumont 2805 Biscayne Blvd., Miami, Fla.
 Duncan & Johnson 6124 So. Parkway Chicago
 Dundee 1313 W. Seventh Clovis, N.M.
 Dunkirk 2120 Balsam, L.A., Cal.
 Duo 424 W. 49th N.Y.C.
 Duplex 1650 Broadway N.Y.C.
 Durham 310 Wilbert Wheeling, W. Va.
 Durson 928 N. Clark L.A., Cal.
 Dyche 1309 Walnut Cincinnati, O.

The Brightest, Happiest Sound Around the World!

THE VILLAGE STOMPERS

Originators of "FOLK-DIXIE"



Current Single

"Those Magnificent Men In Their Flying Machines"

Newest Album Release

"Some Folk, A Bit of Country And a Whole Lot of Dixie"

Personal Management

DUKE NILES PRODUCTIONS

1650 Broadway, N.Y., N.Y.

Musical Direction:
Joe Sherman



Records

D And D 110 West 55th, N.Y.C.
 Dadago 2827 Vineyard St. Los Angeles
 Daisy's 135 W. 125th, N.Y.C.
 Dak 200 W. 54th, N.Y.C.
 Dakota 15 Brookwood, Wyandanch L.I., N.Y.
 Dalton 3745 S. Dalton, L.A., Cal.
 Damic 1650 B'way, N.Y.C.
 Damita 56 W. 45th, N.Y.C.
 Danbill Box 11152, Fort Worth, Texas
 Danbury 2 West 45th, N.Y.C.
 Danby 1619 Broadway, N.Y.C.
 Dandelion 1919 N. Broad St., Phila., Pa.
 Dan-John 1697 Broadway, N.Y.C.
 Dantler's 2049½ Burnside, L.A., Cal.
 Dara 1619 Broadway, N.Y.C.
 Darbnan 6700 Laurel Grove, N. Hollywood
 Darrow N.E. Corner 19th And Ritner, Phila.
 Dart 1453 N. Vine, Hollywood
 Dartmoor 244 W. 48 St, N.Y.C.
 Dark Horse 3009 Keeling Ave., Nashville, Tenn.
 Dasher 65 W. 129th, N.Y.C.
 Da-Tan 2726 S. Orange Drive, L.A., Cal.
 Davoor Box 1183, Newburgh, N.Y.
 David Music, Inc. 1450 Broadway, N.Y.C.
 Davidson 101 W. 55th, N.Y.C.
 Davilene 161 W 54th St, N.Y.C.
 Jimmie Davis 843 Delaware St., Shreveport, La.
 Darl 111 W 57 St, N.Y.C.
 Davon 2101 Ivar, H'wood, Cal.
 Dayfield 3563 Jasmine, L.A., Cal.
 Daylight Box 336 Burbank, Cal.
 Dayroll Box 397, N.Y.C.
 Daywin 250 N. Canon, Beverly Hills, Cal.
 Dazzler 301 Academy, Newark, N.J.

AROUND THE WORLD ON 3 LABELS



Kapp Records, Inc., 136 East 57th Street, New York, N.Y. 10022

BMI PUBLISHERS

Dynamic 1143 W. 17 St. Chicago
Dynasty 1650 Broadway N.Y.C.
Dzona 1370 Fifth N.Y.C.

E & E 8604 S. Maryland Chicago
E & M 2674 Steele Memphis, Tenn.
Eagle 7002 Fifth N.W., Wash. D.C.
Earl 2225 Fifth, N.Y.C.
Walter Earle 126 W. 49th N.Y.C.
Earth 1619 B'way, N.Y.C.
East End 3329 W. 6th Fort Worth, Texas
East 926 E. Mc Lemore Memphis, Tenn.
East Side 2901 Nathan Memphis, Tenn.
Eastern 554 Fifth N.Y.C.
Eastwick 1332 Phila-Natl Bank Phila., Pa.
Ebb 4521 S. Western L.A., Cal.
Ebony Box 542 San Antonio, Texas
Eby 1650 Broadway, N.Y.C.
Ecma 6407 Camelia No. Hollywood, Cal.
Ec-lar 250 W. 57th N.Y.C.
Electric 190 Waverly Place, N.Y.C.
E-D Music 6124 Selma Hollywood, Cal.
Edco 201 W. 49th N.Y.C.
Edeejay 6381 Hollywood Blvd. Hollywood
Eden 1501 Broadway, N.Y.C.
Edgevine 1619 Broadway N.Y.C.
Edgewater 1425 No. Dearborn Chicago
Edu-Lou 200 West 57, N.Y.C.
Edlee 1453 N. Vine Hollywood
Edlock 1225 Sixth N.Y.C.
Edlon 1650 Broadway N.Y.C.
Edmy Box 4259 Phila., Pa.
Edsun 719 Harvard Burbank, Cal.
Edwina 789 Ponce De Leon Atlanta, Ga.
Edwina 4615 Bellview Cincinnati, O.
Eddy-Lou 7 W. 45th N.Y.C.
Eefsee 161 W. 54th N.Y.C.
Efta 608 Fifth Ave, N.Y.C.
Egap 1270 Sixth N.Y.C.
Ejay 424 W. 49th N.Y.C.
Ek 137 Riverside Dr. N.Y.C.
Elco Box 2968 Hollywood
Eldee 33 W. 42nd N.Y.C.
Eldorado 1717 N. Vine Hollywood
Electron 6920 Sunset Hollywood
Elegant 140 W. 57th N.Y.C.
Elenda 6223 Selma Hollywood
Elite 4818 Avalon L.A., Cal.
Elizabeth 8831 Sunset L.A., Cal.
Elk 1322 S. 13th Phila., Pa.
Ellen 3010 14th N.W. Wash. D.C.
Elmhurst 1697 Broadway N.Y.C.
Elmtree 1270 Sixth Ave., N.Y.C.
Elsher 250 S. Broad Phila. Pa.
Elvira 125 W. 45th N.Y.C.
Elvitrue 306 S. 16th Wilmington, N.C.
Embassy 240 W. 55th N.Y.C.
Ember 832 Kendall Dr. Nashville, Tenn.
Emcee 1795 Riverside Dr. N.Y.C.
Emelda 1427 Carondelet St. New Orleans
Emerald 5425 W. Division Chicago
Emerson 725 Riverside Dr. N.Y.C.
Emit 165 W. 46th N.Y.C.
Emkay 1619 Broadway, N.Y.C.
Emorey 1650 Broadway, N.Y.C.

Emperor 1650 Bway N.Y.C.
Enak 1697 Broadway, N.Y.C.
End 1650 Broadway, N.Y.C.
Englewood 6650 Sunset Hollywood
English 801 17th Ave S., Nashville, Tenn.
Enrica 1697 Broadway, N.Y.C.
Enright 1070 Howard San Francisco
Entertainment 575 Madison N.Y.C.
Epitome 7611 S. Normal Blvd., Chicago, Ill.
Epps Box 4284 San Antonio, Texas
Era 1065 Willow Glen Way San Jose, Cal.
Ercolani 9614 Heather Road Beverly Hills, Cal.
Eric 6425 Hollywood Blvd. Hollywood
Ermont 800 Presido Ave, San Francisco
Escapade 1650 B'way, N.Y.C.
Esco 112 Nathan Road S.W. Atlanta, Ga.
Escort 1724 1/2 W. 36th L.A., Cal.
Esquire 400 Madison N.Y.C.
Essay 238 S. Peck Dr. Beverly Hills, Cal.
Essex 1619 Broadway N.Y.C.
Esteem 488 Madison N.Y.C.
Estella 235 W. 46th N.Y.C.
Estey 5880 Hollywood Blvd. Hollywood
Ethel Mae I and Schiller, Phila., Pa.
Ettry 1619 Bway., N.Y.C.
Eureka 115 E. 119th, L.A., Cal.
Euterpe 4104 Witzel Dr. Sherman Oaks, Calif.
Evar 5800 Third, L.A., Cal.
Eve 700 S. Dearborn Chicago
Evergreen 2001 Main Dallas, Texas
Everlast 2294 8th, N.Y.C.
Exbrook 9110 Sunset L.A., Cal.
Excellorec 177 Third Ave. Nashville, Tenn.
Exchange 119 W. 57, N.Y.C.
Expansion 201 W. 49 N.Y.C.
Explorer 239 Hillside Newark, N.J.
Expo 4209 Parkmont Baltimore, Md.
Extra 301 E 47th., N.Y.C.
Ez-win 1681 Third N.Y.C.

F.A.A. 5019 Normanide L.A., Cal.
F.M.E. 13842 Robson, Detroit, Mich.
Fab 54 W. Randolph Chicago
Fabor 2609 W. Olive Burbank, Cal.
Fabulous 1320 Vine Phila., Pa.
Fairbanks-Mellin 1650 Broadway N.Y.C.
Fairfield 916 Kearny San Francisco
Fairmount 1200 Walnut Phila., Pa.
Fairview 511 Fifth N.Y.C.
Faith 2031 Tennessee Dallas, Texas
Fall River 200 W. 57th N.Y.C.
Falstaff 7966 Beverly Blvd L.A., Cal.
Fann 5880 Hollywood Blvd., Hollywood
Fantastic 150 W46, N.Y.C.
Faro 5004 Melrose, Hollywood
Farout 64 E. 55th N.Y.C.
Fashion 844 Thomas Memphis, Tenn.
Fast 271 W. 125th N.Y.C.
Ed Fay 4934 S. Wilton Place L.A., Cal.
Fayhill 1650 Broadway N.Y.C.
Fearless 4421 Van Home, L.A., Cal.
Feather 292 Madison N.Y.C.
February 13 E. 22nd N.Y.C.
Fee Bee 4517 Wainwright Pitts., Pa.
Gertrude Feith, Box 248, Pine Bluffs, Wyo.
Fellows 1018 N. Watkins, Memphis, Tenn.

Felsted 539 W. 25th N.Y.C.
Fergus 18100 Greenlawn, Detroit, Mich.
Fern 1650 Broadway N.Y.C.
Ferncliff 1829-12th St. N.W., Wash., D.C.
Fernwood 1404 Hull So. Norfolk, Va.
Jose Ferrer 375 Park N.Y.C.
Fi-Del 305 W. 52nd N.Y.C.
Fidelity 5139 St. Antoine, Detroit, Mich.
Fiesta Box 2471 Hollywood
Fifty Third Street 815 W. 53rd, N.Y.C.
Figure 1650 Broadway N.Y.C.
Film & T.V. 11360 Dona Dorotea Dr. Studio City, Cal.
Finch Box 48 Cincinnati, O.
Fine Arts 1425 Broadway N.Y.C.
Fine Songs 1501 Bway N.Y.C.
Finnie 2078 Calvert, Detroit
Fiore, 708 5th St Struthers, O.
Fire 565 Fifth N.Y.C.
Fireball 322 W. 48, N.Y.C.
Firefy 1674 Broadway N.Y.C.
First Award 10724 Bloomfield St, N. H'wood, Calif.
H B Fisher 54 W Randolph Chicago, Ill.
Flair 9317 W. Wash. Blvd., Culver City, Cal.
Flaka 511 Fifth N.Y.C.
Flame 2611 E. 13th Brooklyn
Flamingo Box 1732, Hollywood, Cal.
Flanagan 1740 B'way, N.Y.C.
Flatt & Scruggs 201 Donna Madison, Tenn.
Ray Fleming 251 W. 42 St, N.Y.C.
Fleet 1323 S. Michigan Chicago
Flick 18559 Ryan Rd. Detroit, Mich.
Flip and Skip 41 St. Nicholas Terrace, N.Y.C.
Flipside 1607 N. El Centro Hollywood
Florence 4215 W. Fifth Chicago
Florida 1650 Broadway, N.Y.C.
Floridian 407 Lincoln Road Miami Beach, Fla.
Folk Songs 12021 1/2 Otsego, N. Hollywood
Folkways 10 Columbus Circle, N.Y.C.
Fool Killer 25 W 56, N.Y.C.
Footlight 729 Seventh N.Y.C.
Ford 132 Nassau N.Y.C.
Fore-Site 6865 Selma Hollywood
Formation 324 W. 84th St, N.Y.C.
Forrest Hills 1607 Hawkins Nashville, Tenn.
Forsay 1681 Broadway, N.Y.C.
Forty-Four 235 E. 45th N.Y.C.
Fountainhead Box 1223, N.Y.C.
Four Jays 9425 Sunset, Beverly Hills, Calif.
Four Saints 1701 16th Ave., So. Nashville, Tenn.
Four Star 1556 N. La Brea Hollywood
Four Star Television 4030 Radford Ave., No. Hollywood
Wallace-Fowler 1556 No. La Brea, Hollywood
Kim Fowley 6000 Sunset Blvd., Hollywood
Ray Fox Music 1480 Spruce Phila. Pa.
Francapp 401 Broadway N.Y.C.
Franjo 1650 Broadway, N.Y.C.
Franklin 163 W. 57th N.Y.C.
Frannan 8983 Sunset Blvd. Hollywood
Fraum 11936 Burbank Blvd., N. Hollywood
Frazier & Goodson 329 W. 60th L.A., Cal.
Frederick 1323 S. Michigan Chicago
Albert Edward Freeman 426 E. 68th N.Y.C.
Fremart 1467 N. Vine Hollywood

*Fremont 360 N. Michigan Chicago
Friday Music 1549 N. Vine Hollywood
Friendship 608 Fifth N.Y.C.
Frigate 608 Fifth N.Y.C.
Frisco 1140 N. Claiborne New Orleans, La.
Frank L. Frish 2457 S. Central Park Chicago
Frost 1631 Broadway N.Y.C.
Fulton 530 Divisadero, San Fran., Cal.
Fuqua 592 Farnsworth Detroit, Mich.
Fury 5659 Heiskell Phila., Pa.
G & H 1510 Fairmount Phila., Pa.
G and M 1220 S. Sunol Dr. L.A., Cal.
G.G. 9460 Wilshire Beverly Hills, Cal.
G-Note 1650 Broadway N.Y.C.
Gabby 127 W. 70th St, N.Y.C.
Gail Music Corp. 501 Madison, N.Y.C.
Gala 55 W. 53rd N.Y.C.
Gale & Gayles 250 W. 57, N.Y.C.
Gallatin 9033 Wilshire, Beverly Hills, Cal.
Gallon 850 Seventh N.Y.C.
Al Gallico, 101 W. 55th St., N.Y.C.
Gallo 8462 Sunset L.A., Cal.
Galrek 756 Seventh Ave., N.Y.C.
Gant 10606 Larchfield Dallas, Texas
Garcliff 9808 Wilshire Beverly Hills, Cal.
Garden of Allah 5548 S. Kildare, Chicago
Garlock 475 Fifth N.Y.C.
Garopa 3490 Wade L.A., Cal.
Garpax Box 669 Hollywood
Garrett 148 E. 47th N.Y.C.
Gaslight 1650 Broadway N.Y.C.
Gaviota 1515 Crossrds of World, Hollywood
Gavy 915 Isabel L.A., Cal.
Evelyn Gay 6544 Champlain Chicago
Gay 1518 Pine, St. Louis, Mo.
Gayjo 2526 W. Kiest Dallas, Texas
Gaystar 1443 W. 64th, L.A., Cal.
Gee-Clef 445 W. 50th N.Y.C.
Geeting 117 17th Ave. So., Nashville, Tenn.
Gezinslaw 480 Blecker, Mamaroneck, N.Y.
Julius W. Geier 522 Fifth N.Y.C.
Gele 3432 Mentone L.A., Cal.
Genson 6425 Hollywood Blvd., Hollywood
Gentry 140 W. 57th N.Y.C.
Georgal 30 E. 60th N.Y.C.
Georgette 16 W. 30th N.Y.C.
Gerald 4308 N. Spaulding Chicago
Gerson & Sullivan 743 Fifth N.Y.C.
Ghana 5216 1/2 Calumet Chicago
Giant 1617 N. El Centro Hollywood
Gil 1650 Broadway N.Y.C.
Gilbert 1619 Bway, N.Y.C.
Johnny Giles 6568 Barton Hollywood
Gil-Kay 1326 Telford Cincinnati, O.
Gillian 325 W. 45th N.Y.C.
Al Gilray 6369 Delongpre, Hollywood
Gil-Tone 5537 Irving Phila., Pa.
Glad 314 E. Eleventh Houston, Texas
Glaser 146 7th Ave., Nashville, Tenn.
Glasgow Music Box 3103 Dallas, Texas
Glen Cove 200 W. 58th N.Y.C.
Glenayre 6 East Lake Chicago
(Continued on next page)



My Sincere Thanks To You All

#1 Female Vocalist 1964
(Cash Box Year End Survey)

LESLEY GORE

LATEST HIT SINGLE

**SUNSHINE
LOLLIPOPS
&
RAINBOWS**

Mercury 72433

EXCLUSIVELY



PUBLIC RELATIONS
CONNIE DE NAVE
200 West 57th St., NYC



LONDON
PARIS
TOKYO
ROME
MILAN
FRANKFORT
MADRID
TEL AVIV
STOCKHOLM
AMSTERDAM
BUENOS AIRES

AUSTRALIA
NEW ZEALAND
SOUTH AFRICA
MEXICO
BRAZIL
PORTUGAL

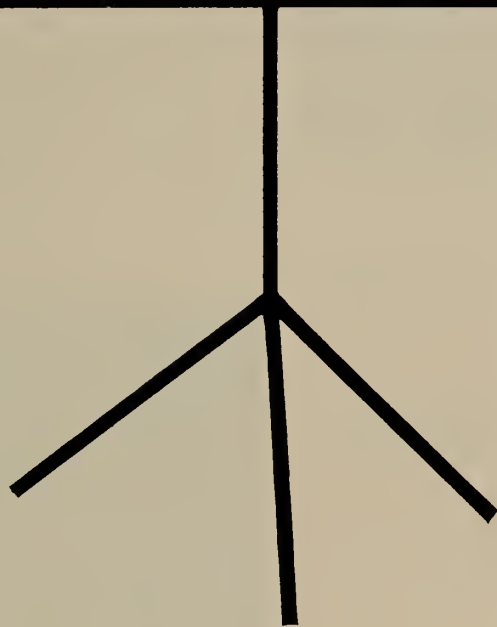

COMPLETE REPRESENTATION
THROUGH OUR WORLD-WIDE OFFICES



729 SEVENTH AVENUE, NEW YORK 10019

BMI PUBLISHERS

Jonathan Glenn 57 W. 56th N.Y.C.
 Glenn-Regan 157 W. 57th N.Y.C.
 Glen-Ron 4729 N. Campbell Chicago
 Glenville 473 West End Ave., N.Y.C.
 Glenway 2308 W. 8th Cincinnati, O.
 Glenwood 1800 N. Argyle Hollywood
 Glick 1245 N. Vine Hollywood
 Glodis 1650 Broadway N.Y.C.
 Glo-Mac 6920 Sunset Blvd., Hollywood
 Gloreco 11558 La Salle Detroit, Mich.
 Glory 6421 Moore Dr. L.A., Cal.
 Glover 1697 Broadway N.Y.C.
 Glow 756 Seventh Ave. N.Y.C.
 Gobblers 7740 Mulholland L.A., Cal.
 Go-Go 11935 Bray Ave. L.A., Cal.
 Gold Clef 27 W. Chelton, Chester, Pa.
 Gold Cup 6920 Sunset Hollywood
 Gold Label 565 Fifth N.Y.C.
 Gold Tone 150 W. 46 N.Y.C.
 Goldband 1240 Hill Dr. L.A., Cal.
 Golden Gate 48 W. 48th N.Y.C.
 Jo Golden 101 S.W. 55th Miami, Fla.
 Golden Key 3456 Floyd Terrace L.A., Cal.
 Golden Rule 5353 Indiana Chicago
 Golden State Box 115 Madison, Tenn.
 Golden Tone Box 38502, Hollywood
 Golden Tune 12661 Tuller, Detroit, Mich.
 Golden West Melodies 1556 N. La Brea, Hollywood
 Golden World 15004 Mack Ave. Detroit, Mich.
 Gold-Ridge 1556 N. La Brea Hollywood
 Gollatz 54 W. Randolph Chicago
 Good Songs 150 W. 55th N.Y.C.
 Goose 3415 McKinley L.A., Cal.
 Gopam 119 W. 57th N.Y.C.
 Gopus 48 W. 48th N.Y.C.
 Gordon & Lefleur 66 W. 87th N.Y.C.
 Gordon 408 N. Rodeo Dr. Beverly Hills, Cal.
 Gorham 470 West End Ave., N.Y.C.
 Gorjay 335 W. 84th N.Y.C.
 Gospel 1619 Broadway N.Y.C.
 The Gospel Clef 320 Broadway N.Y.C.
 Gospelstone 1001 Capitol Access Rd., Baton Rouge, La.
 Gotham 2 W. 46th N.Y.C.
 Gotopro 521 W. 57 St. N.Y.C.
 Gott 101 W. 55th N.Y.C.
 Governor 15022 Ventura, Sherman Oaks, Cal.
 Gower 711 Fifth N.Y.C.
 Gralow 60 W. 46th N.Y.C.
 Granada 200 W. 57th N.Y.C.
 Grandye 117 17th Ave. S., Nashville, Tenn.
 Grange 831 S. Wabash, Chicago
 Granite 1651 Cosmo Hollywood
 Granson 1608 Argyle Hollywood
 Grant 1650 Broadway N.Y.C.
 Greenleaf Music 1619 Broadway N.Y.C.
 Green Water 420 E 55, N.Y.C.
 Gregmark 1610 N. Argyle Hollywood
 Greg-Moore 79 W. Monroe Chicago
 Greta 1619 Broadway N.Y.C.
 Greyco 640 Fifth N.Y.C.
 Griffith 608 Fifth Ave. N.Y.C.
 Grille 617 Exchange Bldg., Nashville, Tenn.
 Groove 43 W. 61st N.Y.C.

Groovesville 2452 Calvert Detroit, Mich.
 Groton 444 Madison Ave. N.Y.C.
 Guard 665 Harrison San Francisco, Calif.
 Guild 2511 Mayberry St., L.A., Cal.
 Guitar 6515 Sunset Blvd, H'wood
 Morris Gurlek 1631 Broadway, N.Y.C.
 Dan Guy 5607 Melrose Hollywood
 Gyro 873 Beecher Cincinnati, O.
 Gyurik 232 W. 48th St., N.Y.C.

H & K 119 W. 57th N.Y.C.
 H & L 1631 Broadway N.Y.C.
 H & W 2817 W. Pico L.A., Cal.
 H. E. G. 1107 N. El Centro Hollywood
 Ha-So 13938 Vanowen, Van Nuys, Calif.
 Hackney 629 Waveland Chicago
 Haimish 1607 Vista Del Mar, Hollywood
 Frank J. Halama 2346 W. Thomas, Chicago
 Halbrook 1697 Broadway N.Y.C.
 Hall Clement 888 Pearl St., Beaumont, Texas
 Hall of Fame Box 921 Beverly Hills, Cal.
 Hallie 4736 Sancelo N. Hollywood
 Hal-Rudd 1607 El Centro Hollywood
 Hama and Rhodes 2339 So. Coats, Los Angeles
 Hamblen 7740 Mulholland Dr., L.A., Cal.
 Hambone 2885 W. 14th Cleveland, O.
 Hammock 948 N. 4th Knoxville, Tenn.
 Hampton 136 W. 52nd N.Y.C.
 Hand Bennie Dillon Bldg., Nashville, Tenn.
 Hannibal Box 232 N.Y.C.
 Happy Hearts 1619 Broadway N.Y.C.
 Hara 632 Madison Memphis, Tenn.
 Har-Bock 8715 W. 3rd L.A., Cal.
 Harco 149 W. 48th N.Y.C.
 Louis Hardin 101 W. 44th N.Y.C.
 Franck Harding 136 W. 52nd N.Y.C.
 Harlan 1332 Phil. Nat. Bank Bldg. Phila. Pa.
 Harlequin 505 Ardmore Dr. Minneapolis, Minn.
 Harley 3432 Mentone L.A., Cal.
 Harold & Dimple 1241 W. 60th L.A., Cal.
 Harold 442 W. 57th N.Y.C.
 Harper & Brothers 49 E. 33rd N.Y.C.
 Harris & Vavrin 54 W. Randolph Chicago
 Harrose 12626 Kling N. Hollywood
 Hartsdale 2 W. 45th N.Y.C.
 Alan Hartwell 825 Madison N.Y.C.
 Harvard 1619 Broadway N.Y.C.
 Harvey 1518 No. Gower, Hollywood
 Hastings 1540 Broadway N.Y.C.
 Hawaii Revue Studios, Universal City, Cal.
 Hawk 1733 Broadway N.Y.C.
 Haymarket 6515 Sunset Hollywood
 Lee Hazlewood 6515 Sunset Hollywood
 Heatherfield 1697 Broadway N.Y.C.
 Heatherton 853 Seventh Ave., N.Y.C.
 Hebraica-Glantz 156 W. 44th St. N.Y.C.
 Heigh-Ho 507 Fifth Ave., N.Y.C.
 Heiress 1631 Broadway, N.Y.C.
 Helios 1619 Broadway, N.Y.C.
 Hemlock Box 2243 Nashville, Tenn.
 Henderson 125 Windemere Rd., Staten Island, N.Y.
 Hennessey 1650 Broadway, N.Y.C.
 Henry 25 W. 56th N.Y.C.

Henry-Wade 3941 Woodlawn Dr. Nashville, Tenn.
 Herb-Hunt 1032 Fourteenth Ave. N., Nashville, Tenn.
 Herb-Mor 1545 No. Las Palmas, Hollywood
 Ray Herbert 1650 B'way, N.Y.C.
 Hercules 1270 Sixth N.Y.C.
 Hermes 6408 1/2 Hollywood Blvd, Hollywood
 Dolph Hewitt 1230 W. Washington, Chicago
 Ersel Hickey 1619 Broadway N.Y.C.
 Hickory Lake 905 16th Ave, Nashville
 Hidden Valley 292 Madison N.Y.C.
 Hide 1600 N. La Brea Hollywood
 Hi-Fi 5712 Camellia N. H'wood, Cal.
 High Mountain 226 7th Ave, Nashville
 Highridge 916 Kearney San Francisco
 Hi-Hoss 1697 Broadway N.Y.C.
 Hilldale 14801 Piedmont, Detroit, Mich.
 Hildy 1650 Broadway N.Y.C.
 Hill and Range 1619 Broadway N.Y.C.
 Mary Hill 8500 Fayette, Phila. Pa.
 Hillart 2854 W. Pico L.A., Cal.
 Hillary 1481 N. Vine Hollywood
 Hillbilly 14 E. 77th N.Y.C.
 Hilliard 1717 N. Highland Hollywood
 Hillsboro Box 275 Nashville, Tenn.
 Hillside 1626 No. Vine Hollywood
 Hill-Town 628 Exchange Bldg. Nashville Tenn.
 Hi-Lo 639 Madison Memphis, Tenn.
 Hilton-Gregg 1651 Cosmo Hollywood
 Hi-Mi 7750 S. Calumet Chicago
 Hinds, Hayden & Eldredge 589 Fifth, N.Y.C.
 Hinkle 1040 N. Las Palmas Hollywood
 His 19273 Warrington, Detroit, Mich.
 Hit Tunes 4211 Madison Culver City, Cal.
 Hi-Tone 1733 Broadway N.Y.C.
 Hits of Tomorrow Box 841, Hammond, Ind.
 Hitsville 1697 Broadway N.Y.C.
 Hob 111 Mack Detroit, Mich.
 Hob & Nob 158 W. 15th, N.Y.C.
 Hoffman House 1549 N. Vine Hollywood
 Hollenden 1631 Broadway N.Y.C.
 Hollis 10 Columbus Circle, N.Y.C.
 Holly House 1321 W. Seventh Clovis, N.M.
 Hollycrest 3058 Hollycrest Pl., Hollywood
 Hollyvale 1607 El Centro, Hollywood
 Hollyvine 8597 Appian Way Hollywood
 Hollywood Star 557 N. Kenmore, L.A., Cal.
 Homer 3725 Woodward Detroit, Mich.
 Homer & Jethro 3308 S Manor Drive, Lansing, Ill.
 Hood 12251 Crewe, N. Hollywood
 Hopewell 1619 Broadway N.Y.C.
 Horizon 1619 Bway, N.Y.C.
 Horn 962 N. Ardmore Hollywood
 Sampson Horton 1697 Broadway N.Y.C.
 House of Fior 6365 Selma Hollywood
 House of Fortune 6557 Barton Hollywood
 House of Sound 130 S. Breed L.A., Cal.
 Jack Howard 2733 Kensington, Phila, Pa.
 Hullabaloo 6223 Selma Hollywood
 Hummingbird 1612 Vista Del Mar Hollywood

Ross Hunter 250 N. Canon Dr. Beverly Hills, Cal.
 Husky 806 16th Ave. S., Nashville, Tenn.
 Hut P.O. Box 6 Memphis 4, Tenn.
 Hutchinson 119 W. 57th N.Y.C.

Iantha 136 W 52, N.Y.C.
 Iberia 1733 Broadway N.Y.C.
 Ichabod 550 Fifth N.Y.C.
 Ichi-Ban 1650 Broadway N.Y.C.
 Immediate 1841 B'way, N.Y.C.
 Impromptu Tunes 4413 Visla Place, La Canada, Calif.
 Indigo 1501 Broadway N.Y.C.
 Autry Inman 2821 Druid Dr. Nashville, Tenn.
 Inspirational 1619 Broadway N.Y.C.
 Integrity 2 West 46th St. N.Y.C.
 Intermountain 135 S. Third East, Salt Lake City, Utah
 International Tunes 1036 N. Dearborn Chicago
 Interstate 630 Fifth N.Y.C.
 Intrinsic 4401 W. Verdugo No. Hollywood
 Inxie 250 W. 57th N.Y.C.
 Iola 1697 Broadway N.Y.C.
 Iraci 119 W. 57th N.Y.C.
 Iris-Trojan 37 W. 57th N.Y.C.
 Irving 8255 Sunset Los Angeles
 Island 15609 Damon Cleveland, O.
 Islip 120 West Bayberry Rd. Islip, L.I., N.Y.
 Ivel 200 W. 57th N.Y.C.
 Ivy-Gee 1650 Broadway N.Y.C.
 Iza 1650 B'way, N.Y.C.

J. Little 1650 Broadway N.Y.C.
 J.V.B. 8620 12th Detroit Mich.
 Jack Box 2423 Beaumont, Texas
 Jadco 5 S. 60th Phila, Pa.
 Jaep 221 W 57, N.Y.C.
 L.B. Jaffe 14722 Broadway N.Y.C.
 Jaglea 1650 Broadway N.Y.C.
 Jaguar 8582 Sunset, Los Angeles
 Jalo 1916 Fairbank Rd., Baltimore, Md.
 Jalynne 2203 Spruce Phila, Pa.
 Ahmad Jamal 1525 E. 53rd Chicago
 James 6223 Selma Hollywood
 Jambicoor 236 7th Ave., N.Y.C.
 Jamboree 5050 W. Fletcher Chicago
 Dick James Music 221 W 57, N.Y.C.
 Jamie 1919 N. Broad St., Philadelphia, Pa.
 Jandee 2124 Cabuenga Hollywood
 Jane 405 E. 54th N.Y.C.
 Janes-Robinson 1692 Madison Memphis, Tenn.
 Jania 1155 Milwaukee Chicago
 Janice 200 W. 57th N.Y.C.
 Janie 7947 S. Constance Chicago
 Janjo 54 W. Randolph Chicago
 January 25 W 56, N.Y.C.
 Jar 136 W. 52nd N.Y.C.
 Jason 157 W. 57th N.Y.C.
 Jat 1556 N. La Brea Hollywood

(Continued on next page)

CONGRATULATIONS TO CASH BOX

on your
23rd

From

STU PHILLIPS

his orchestra
and chorus

and many more,

Stu Phillips



BMI PUBLISHERS

thanks
to
all
my
friends



Brook Benton

current single

**"LOVE
ME
NOW"**

Mercury #72446

personal management

Buddy Friedlander
FOUR BEES ENTERPRISES, INC.
850 Seventh Ave.
New York, N. Y.
JU 6-8790



Jay & Cee, see Lois
Jay Jay 2452 S. Kedzie Chicago
Jaybee 40 E. 49th N.Y.C.
Jay-Boy 1790 Broadway N.Y.C.
Jayco 157 W. 57th N.Y.C.
Jayde 36 W. Randolph Chicago
Jay-El 1616 N. Argyle Hollywood
Jaymond 222 E. 46th N.Y.C.
Jayson 1650 Broadway N.Y.C.
Jazz Standard 235 W. 46th N.Y.C.
Jazz Workshop 2186 Fifth N.Y.C.
Jeanick 1916 Fairbanks Rd., Baltimore, Md.
Jee 308 Poplar Memphis, Tenn.
Jeeo 1650 Bway N.Y.C.
Jeff-Paul Carlton House Pittsburgh, Pa.
Jefmark 200 W. 57th N.Y.C.
Jehad Productions 49 W. 19 St. N.Y.C.
Jen-Shem 2640 S. Kildare Chicago
Jepalana 723 Seventh N.Y.C.
Jess 369 Lexington Ave., N.Y.C.
Jet 7332 S. Calumet Ave., Chicago
Jimber 8588 West Pico L.A. Cal.
Jim-Jam 1650 Broadway N.Y.C.
Jimskip 136 W. 52nd N.Y.C.
Joaneline 1619 B'way, N.Y.C.
Jo-Bar 756 7 Ave., N.Y.C.
Jobete 2648 West Grand Detroit, Mich.
Jodax 119 W. 57th N.Y.C.
Joel 511 5th Av., N.Y.C.
Jo-Gene Shelton Towers Hotel N.Y.C.
John L. 1520 E. 67th Pl., Chicago
Johnstone-Monteil 6087 Sunset Hollywood
Joi-See 1717 N. Vine Hollywood
Joli 1619 Broadway N.Y.C.
David Jones 345 W. 58th N.Y.C.
Joni 1449 S. Michigan Chicago
Jon-Jay 1619 Broadway N.Y.C.
Jonware 515 Madison N.Y.C.
Kappy Jordan 575 West End N.Y.C.
Josette 1207 E. 53rd Chicago
Joshua 50 W. 57th N.Y.C.
Joslow 131 South Croft, Los Angeles
Jot 2203 Spruce Phila., Pa.
Jowcol 120 E. 56th N.Y.C.
Joyall 1435 Huffine Nashville, Tenn.
Joyce 6087 Sunset Hollywood
Judge 232 W. 48th N.Y.C.
Judoe 525 Lexington N.Y.C.
Judson 1650 Broadway N.Y.C.
Judy-Jim 2712 Hartford Dr. Nashville, Tenn.
Julie 120 W. 57th N.Y.C.
Julmer 521 Fifth N.Y.C.
Juno 6734 1/2 Selma Hollywood
Just 35 W. 45th N.Y.C.
Justis 639 Madison, Memphis, Tenn.

K and G 200 W. 57th N.Y.C.
K & S 1740 Broadway N.Y.C.
K-M 19 E. 53rd N.Y.C.
Kags 6425 Hollywood Blvd Hollywood
Kalet-Nelson 118 W. 57th St., N.Y.C.
Kalin 333 E. 34th N.Y.C.
Kalith 1619 Broadway, N.Y.C.
Kam 410 Park, N.Y.C.
Kamar Box 115, Madison, Tenn.
Kampus 616 S. Michigan, Chicago
Les Kangas 7902 Dewey, San Gabriel, Cal.
Kansoma 6418 Camrose Ter., Bethesda, Md.
Kapa 3232 Clairmount, Detroit, Mich.
Kapen 1485 N. Vine, Hollywood
Karel 3215 Ave H B'klyn, N.Y.
Kari 3380 Pasadena, Detroit, Mich.
Karlan 1449 S. Michigan, Chicago
Karyn Helene 507 Fifth, N.Y.C.
Kasen 461 8 Ave, N.Y.C.
Katrina 1970 Lauretta, Memphis, Tenn.
Kavelin 7250 Beverly, L.A., Cal.
Kayak 207 E. 31st, N.Y.C.
Kaybee 9100 Sunset, Hollywood
Kayro, Revue Studios, Universal City, Cal.
Keble 1501 Broadway, N.Y.C.
Keel 1595 Broadway, N.Y.C.
Keetch, Caesar & Dino 1650 B'way, N.Y.C.
Keg 12762 Sherman Way, N. Hollywood
Kelco Inc. 250 W. 57th., N.Y.C.
Kelly 20 E. Jackson, Chicago
Pete Kelly 4024 Radford, No. Hollywood
Kemo 6087 Sunset, Hollywood
Kemp 1165 Broadway, N.Y.C.
Kempto 2 W. 45th St., N.Y.C.
Ken Marlow 617 Exchange Bldg., Nashville, Tenn.
Kendall 7732 Claremont Dr., Dallas, Texas
Kenmar 617 Exchange Bldg., Nashville, Tenn.
Kenmel 2218 S. 19th, Phila., Pa.
Kennecott 1650 Broadway, N.Y.C.
Kenneth 4538 1/2 Russel, Hollywood, Cal.
Kennetta 12118 Louis Ave., Whittier, Calif.
Kenny 1674 Broadway, N.Y.C.
Ken-Rick 4965 Bruce, Beaumont, Texas
Kensington 1501 Broadway, N.Y.C.
Kenson 200 W. 57th., N.Y.C.
Kentucky 1619 Broadway, N.Y.C.
Kenwood 1619 Broadway, N.Y.C.
Bob Kerr 1270 6th., N.Y.C.
Ketchy 1697 Broadway, N.Y.C.
Keva 604 Exchange Bldg., Nashville, Tenn.
Keystone 1619 Broadway, N.Y.C.
Kildare 35 E. Wacker Dr., Chicago, Ill.
Kilt 150 W. 55th., N.Y.C.
Kilynn 392 Central Park W., N.Y.C.
Kimberly 686 W. 246th., Riverdale, N.Y.
King Ring 150 W. 55th., N.Y.C.
Kingsland, 2742 E Tremont, N.Y.C.
Kingle 2211 Bowmont, Beverly Hills, Cal.
Kingswood 1525 McGavock St. Nashville
Jack Kinney 3349 Cahuenga Blvd., Hollywood
Kips Bay 157 W. 57th., N.Y.C.
James E. Kirchstein 123 Water., Sauk City, Wis.
Kismet 131 W. 28th., N.Y.C.
Klick 4828 Greenville Ave., Dallas, Texas
Klive 6425 Hollywood, Hollywood
Knightsbridge 1650 B'way, N.Y.C.
Buddy Knox 6920 Sunset., Hollywood
Knox 639 Madison, Memphis, Tenn.
Koe-Gray 2037 W. 79 L.A., Cal.
Konvan 8605 So Bennett, Chicago
Kooba 45 W. 45th., N.Y.C.
Koolwood 125 Addison, Chicago
Koss 6012 1/2 Eleanor, Hollywood
Kostate 119 W. 57th., N.Y.C.
Kram 836 E. 63rd., Chicago
Kreg-Lincoln 1626 North Vine, Hollywood
Kryder 1790 Broadway, N.Y.C.

Lennie La Cour 3330 N. Lake Shore Dr., Chicago
Edward La Mont 3254 W. Grace, Chicago
Label 6500 Yucca, Hollywood
Labeth 185-40 Ilion, St. Albans, L.I. N.Y.
Labonte 5928 Melrose L.A. Cal.
Lach 6223 Selma, Hollywood
Ladnardet 101 W. 55 St., N.Y.C.
Ladnor 1650 Broadway, N.Y.C.
Laine-Simms 8983 Sunset., Hollywood
Lakal 6087 Sunset, Hollywood
Lake Erie 2259 Brush Rd., Cleveland, O.
Lakeside 8736 Sunset Blvd., L.A., Cal.
Lamaja 4159 S. Ellis, Chicago
Lana 1650 Broadway, N.Y.C.
Lancaster 806-16th Ave. S., Nashville, Tenn.
Lancelot, 6515 Sunset, Hollywood
Lancer 1314 Hellerman St., Phila., Pa.
Lanco 6636 Hollywood Blvd., L.A., Cal.
Land Mark, 172 S. Military, Detroit, Mich.
Lan-Den Box 8213, Memphis, Tenn.
Lanfair 1501 S. Wooster, L.A. Cal.
Langley 101 W. 55th., N.Y.C.
Lanier 1225 Sixth, N.Y.C.
Lansdale 1023 N. 67 St., Phila., Pa.
Lar Jan 2817 West Pico, L.A., Cal.
Lar-Bell 9110 Sunset, L.A., Cal.
Larco 1650 Broadway, N.Y.C.
Laredo 1001 N. Lincoln, Burbank, Cal.
Lark 1650 Broadway, N.Y.C.
Larrabee 6381 Hollywood Blvd., Hollywood
Larraha Box 3368, El Paso, Texas
Lash 1326 Kerper, Phila., Pa.
Lasker 3300 Lake Shore Dr, Chicago
Lasso 1306 S. Garnet, Phila., Pa.
Lastar 1549 N. Vine St., Hollywood
Laucan 12044 Chandler, No. Hollywood
Lava 2102 W. 24th., L.A., Cal.
Laval (BMI Canada)
Lavalier 1556 No. La Brea, Hollywood
Tony Lavelli 13 E. 55th., N.Y.C.
Lawana 2549 S. Spaulding, L. A. Cal.
Lawn 4008 S. Ellis, Chicago
Le Bill Box 11152, Fort Worth, Texas
Le Rage 1733 Broadway, N.Y.C.
Le Rue 6404 Hollywood Blvd. Hollywood
Lealan 618 S. Gienwood Pl., Burbank, Cal.
Ernie Lee 36 E. Fifth, Cincinnati, O.
Jay Lee 1650 Broadway, N.Y.C.
Lee-Tee 118 W. 57th., N.Y.C.
Lee-Wall 157 W. 57th., N.Y.C.
Pinky Lee 262 N. Crescent Dr. Beverly Hills, Calif.
Legion 1650 Broadway, N.Y.C.
Leisure 5380 Hollywood Blvd., Hollywood
Lejean 6110 Mayflower, Maywood, Cal.
Lendrof 2105 N. Springfield, Chicago
Lenelle 203 N. Wabash, Chicago
Lenmar 6757 Hollywood Blvd., Hollywood
Lennerts 16055 Warwick Rd., Detroit, Mich.
Lenoir 1538 E. 62 St, Los Angeles
Lenson 781 7th Ave, N.Y.C.
Leopard 1650 Broadway, N.Y.C.
Lerita, SEE January
Lescay 1650 Broadway, N.Y.C.
Lesgor 1619 B'way, N.Y.C.
Levington 157 W. 57th., N.Y.C.
William L. Lewis 2540 W. Pico Blvd., L.A., Cal.
Lido 6266 Sunset, Hollywood
Lighthouse 1650 Broadway, N.Y.C.
Lightning 1248 S. Berendo, L.A., Cal.
Li-Hess 1630 Broadway, N.Y.C.
Liletta 5328 S. Central Ave. Los Angeles
Lillian 2707 W. Pico, L.A., Cal.
Lilly-Jo 2065 Union, Memphis, Tenn.
Liltone 485 Madison, N.Y.C.
Lily 1501 Broadway, N.Y.C.
Limax 618 S. Ridgeley Dr., L.A., Cal.
Limro 1523 W. Flournoy, Chicago
Linco Public Sq., Fayetteville, Tenn.
Linden 1650 Broadway, N.Y.C.
Linduane 240 Central Park S., N.Y.C.
Harry Link R.F.D. New Hyde Park, L.I., N.Y.
Lion 2809 Erastus, Houston, Texas
Lisa 9010 Roselawn, Detroit, Mich.
Lisart 6626 Sunset, Hollywood
Litchfield 6533 Hollywood Blvd., Hollywood
Little Darlin' 7947 Fareholm Dr., L.A., Cal.
Little Dipper 1631 Broadway, N.Y.C.
Little M Box 73542, L.A., Los Angeles 3, Cal.
Little Star Box 26141, Dallas, Texas
Lizann 8983 Sunset, Hollywood
Lloyd and Logan 608 Fifth, N.Y.C.
Loadstone, 163 Orizaba, San Francisco, Calif.
Lobar Music 155 W. 46th., N.Y.C.
Lochmoor 13380 Capital Ave., Detroit, Mich.
Lochrae 485 Madison, N.Y.C.
Locomotive 620 Boscobel Nashville, Tenn.
Locust 11 So. 56th., Phila., Pa.
Lode 812-A N. Hobart, Hollywood
Lois 1540 Brewster Cincinnati, O. 146 W. 54th., N.Y.C.
Lola 457 W. 45th., N.Y.C.
Lollipop 225 W. 36 St. N.Y.C.
Lomer 25 Central Park West N.Y.C.
Lo-Mill 9224 Figuero, L.A., Cal.
Londonderry 275 W. 4th St. N.Y.C.
Lonesome Pine Box 11, Vienna, Va.
Lonette 6515 Sunset, Hollywood
Longbow 1560 N. La Brea, Hollywood
Longhorn 1902 Leeland, Houston, Texas
Lonnie 45 W. 39th., N.Y.C.
Lonzo and Oscar Box 64, Hendersonville, Tenn.
Loom 200 W. 57th., N.Y.C.
Lorelei 124 N. Naomi, Burbank, Cal.
Lorin 1750 N. Vine, Hollywood
Loring 1048 No. Carol Dr. L.A., Cal
Lorob South Road, Harrison, N.Y.
Lorrac 5617 Brushton, L.A., Cal.
Lost 1619 Broadway, N.Y.C.
Loubarry 119 W. 57th., N.Y.C.
Loudwi 6331 Hollywood Blvd., Hollywood
Lovlee 408 W 57, N.Y.C.
Lovlane 15794 Steel, Detroit, Mich.
Low-Ab Box 9687, Atlanta, Ga.
Lowery Box 9687, Atlanta, Ga.
Low-Ja Box 9687, Atlanta, Ga.
Low-Twi Box 9687, Atlanta, Ga.
Loyal 10410 Lagrange, L.A., Cal.
Lucky Duck 826 7 Ave., N.Y.C.
Lucky Hit 511 Fifth, N.Y.C.
Luetta 156 W. 44th., N.Y.C.
Lu-Mar 4755 S. Kenneth Chicago
Lupal 501 Madison, N.Y.C.
Lupine 2930 Boston Blvd., W. Detroit, Mich.
Lu-Tal 2605 Niles Street Bakersfield, Cal.

(Continued on next page)

THANK YOU DJ'S

FOR MAKING ME
ONE OF THE MOST
PROMISING MALE
VOCALISTS OF 1965



RONNIE DOVE

LATEST HIT

"I'LL MAKE ALL YOUR
DREAMS COME TRUE"

DIAMOND 188

CURRENT ALBUM



Personal Management
Phil Kahl —
John O'Donohoe
1650 Broadway
NEW YORK CITY
Ju 6-3876

Exclusive Booking
**ASSOCIATED
BOOKING CORP.**
Joe Glaser

DIAMOND
RECORDS INC

BMI PUBLISHERS

Luther 200 East End Ave., N.Y.C.
Lux 1619 Silverlake, L.A., Cal.
Lyc0 3903 Olive, St. Louis, Mo.
Lyc0ming 101 W. 55th., N.Y.C.
Lynbrook 105-24 63rd Dr., Forest Hills, N.Y.
Kenny Lynch 1619 B'way, N.Y.C.
Lynd 160 W. 46th., N.Y.C.
Lyndale 101 W. 55th., N.Y.C.
Lynve Lewis Tower, 15th & Locust, Phila., Pa.
Lynlou 1270 Sixth, N.Y.C.
Lynn 100 W. 42, N.Y.C.
Ly-Rann 4916 Franklin Rd., Nashville, Tenn

M.J.Q. 881 Tenth, N.Y.C.
MRC 35 E. Wacker Dr., Chicago
MS 2017 No. Argyle, L.A., Cal.
Mable 535 W. 44th., N.Y.C.
Mac-Avery 1697 Broadway, N.Y.C.
Macklin 1610 Camden, L.A., Cal.
Maclen 221 W 57, N.Y.C.
Macmar 3051 Kingston, Memphis, Tenn.
Madchen 157 W. 57th., N.Y.C.
Maddin 2426 Silverlake, L.A., Cal.
Madelon 5607 Melrose, Hollywood
Maestro 1467 N. Vine, Hollywood
Magdon 1040 N. Las Palmas, Hollywood
Maggie 1650 Broadway, N.Y.C.
Magic Circle 604 Commercial Bldg., Shreveport, La.
Magnifico 151 Gertrude Rd. Mamaroneck, N.Y.
Magnolia 14155 Magnolia, Van Nuys, Cal.
Main 589 Fifth, N.Y.C.
Mainstay 101 W 55, N.Y.C.
Main Street 322 W. 48th., N.Y.C.
Major Melodies 1441 Broadway, N.Y.C.
Major Minor 110 W. 55th., N.Y.C.
Mal-Che 35-51 85th., Jackson Heights, N.Y.
Malcom 1776 Broadway, N.Y.C.
Malibu 10756 Wellworth, L.A., Cal.
Mall 427 S. Broad, Phila., Pa.
Malver 424 W. 49th., N.Y.C.
Mamaleen 1800 N. Argle, Hollywood
Management 200 W. 57th., N.Y.C.
Manger 200 West 57th St. N.Y.C.
Manheim 146 E. 57, N.Y.C.
Manistee 9110 Sunset, L.A., Cal.
Manna 1595 Crossrds Of World, Hollywood
Manncy 1 E. 42nd., N.Y.C.
Mansfield 1023 S. Mansfield, Los Angeles
Manu 415 W. 52nd., N.Y.C.
Maple Leaf 1650 Broadway, N.Y.C.
Mar Cal 42 W. 76th., N.Y.C.
Marathon 1607 N. El Centro, Hollywood
Maravilla 6277 Selma, Hollywood
J. T. Marble 1650 Broadway, N.Y.C.
Marcel Box 19581, L.A., Cal.
Marcella 20 W. Alexandrine, Detroit 1, Mich.
Marchester 250 S. Broad, Phila., Pa.
Marcia 1619 B'way, N.Y.C.
Marc-Jean 8831 Sunset, L.A., Cal.
Marcus 1600 N. La Brea, Hollywood
Mardon 6367 Selma, Hollywood
Mares 3308 E. 55th, Cleveland, O.
Marfan 1619 Broadway, N.Y.C.
Margaret 1650 Broadway, N.Y.C.
Margie Carol 2534 W. Pico, L.A., Cal.
Margol 155 W. 46th, N.Y.C.
Marianca 713 Eighteenth Ave., Nashville, Tenn.
Marielle 119 W. 57th, N.Y.C.
Marigold 35 W. 53rd, N.Y.C.
Mariposa 713 18 Ave., S., Nashville, Tenn.
Marizona 713 18th Ave., Nashville, Tenn.
Marjay 1631 Broadway, N.Y.C.
Mark Nine 1900 5th Ave, N.Y.C.
Markham 408 N. Rodeo Dr., Beverly Hills, Cal.
E. B. Marks 136 W. 52nd, N.Y.C.
Marla 34 Leroy St., Tenafly, N.J.
Marlane 52 Remsen Rd., Great Neck, N.Y.
Marlboro 1619 Broadway, N.Y.C.
Marlinda 27 Stegman Pl., Jersey City, N.J.
Marlyn 550 Fifth, N.Y.C.
Marmaduke, 8 & 48th, N.Y.C.
Marna 12333 Ventura, Studio City, Cal.
Marneshek 1650 Broadway, N.Y.C.
Mar-Nick 1320 Vine, Phila., Pa.
Marpat 200 W. 57th St., N.Y.C.
Mar-Pet 1814-22 S. 11th, Phila., Pa.
Marsal 518 2nd, Phila., Pa.
Marsh 14637 Huston, Sherman Oaks, Cal.
Marshall 565 Fifth, N.Y.C.
Martel 24 Terrace Dr., Huntington Station, L.I., N.Y.
Martin & Morris 4315 Indiana, Chicago
Troy Martin, James Robertson, Seventh Ave. No., Nashville, Tenn
Martrick 350 Madison, N.Y.C.
Marty's 713 18th Ave., Nashville, Tenn.
Marville 408 W. 57th, N.Y.C.
Mary 3456 Flovd Terrace, L.A., Cal.
MaryJune 7165 Sunset, Hollywood
Maryland 5415 Lynview, Baltimore, Md.
Mason & Dixon 1557 W. 123rd, L.A., Cal.
Massa 112 E. Walton Pl., Chicago
Massarella 2749 S. Archer, Chicago
Masterclassics 1529 N. Brood St., Phila.
Masterworks 240 Cherokee Rd., Nashville, Tenn.
Matador 768 Eleventh, N.Y.C.
Mataram 4348 Lockwood, L.A., Cal.
Maureen 1697 Broadway, N.Y.C.
Maverick Box 669, Hollywood
Maxine 1650 Broadway, N.Y.C.
Ray Maxwell 6359 Selma Ave., Hollywood
Mavco 225 Broadway, N.Y.C.
Maygar 165 West End Ave, N.Y.C.
Mavhew 8 E. 48th, N.Y.C.
May-Loo 6087 Sunset, Hollywood
Maytime 6087 Sunset, Hollywood
Maywood 5499 Lime, Long Beach, Cal.
Maze 6064 Hollywood, Hollywood
Mazzan 1321 S. Michigan, Chicago
McClellan 1650 Broadway, N.Y.C.
McClure 6526 Selma, Hollywood
Walter Brownie McGhee 254 E. 125, N.Y.C.
Jack Meakin 3338 Waverly Dr., Hollywood
Medal 234 W. 56th, N.Y.C.
Media 211 W. 58th, N.Y.C.
Melba 200 W. 54th, N.Y.C.
Mel-Hi 1650 Broadway, N.Y.C.
Melhouse 119 W. 57th, N.Y.C.
Melinda 60 W. 68th, N.Y.C.
Melissa 1637 Vista Del Mar, Hollywood
Robert Mellin 1650 Broadway, N.Y.C.
Mellow 1650 Broadway, N.Y.C.
Melmar 3017 Vista, Phila., Pa.
Mel-Mat 215 Davis, Taylor, Texas
Melody House 958 W. Edgemont Dr., San Bernardino, Calif.

Melody Lane 1619 Broadway, N.Y.C.
Melody Trails 10 Columbus Circle, N.Y.C.
Melotone Box 3194, N.Y.C.
Melva 2148 S. St. Louis, Chicago
Memo 157 W. 57th, N.Y.C.
Merc-Del 31 W. Illinois, Chicago
Mercedes 1554 N. Gower, Hollywood
Merge 136 E. 57th, N.Y.C.
Meridian 31 W. 54th, N.Y.C.
Mermaid 200 W. 57th, N.Y.C.
Merrick 237 W. 51st, N.Y.C.
Merrimac 1619 Broadway, N.Y.C.
Merry Bell 1714 N. Ivar, Hollywood
Merymount 47 W. 63rd, N.Y.C.
Mesa 1151 S. Broadway, L.A., Cal.
Mester Box 7753, Detroit, Mich.
Met 1794 Chelsea, Memphis, Tenn.
Meteor 6533 Hollywood Blvd., Hollywood
Metorion 117 W. 48th, N.Y.C.
Metric 6920 Sunset, Hollywood; 1650 B'way, N.Y.C.
Mezzo 7633 S. Indiana, Chicago
Mia Sola 156 W. 44th St, N.Y.C.
Miecl's 450 N. May, Chicago
Michele 6724 Allott, Van Nuys, Cal.
Michigan 1501 Broadway, N.Y.C.
Midgeys 393 Seventh, N.Y.C.
Mid-West 667 W. Hancock, Detroit, Mich.
Midwood 1619 Broadway, N.Y.C.
Mighty Magic 9301 Wilshire Blvd, Beverly Hills, Calif.
Miglow 130 W. 42nd., N.Y.C.
Miken 516 Fifth, N.Y.C.
Milbern 723 Seventh, N.Y.C.
Milky Way 608 Fifth, N.Y.C.
Miller Songkraft 1597 Broadway, N.Y.C.
Millie 8 E. 48th, Street, N.Y.C.
Milma 788 Columbus, N.Y.C.
Milsat 608 Fifth Avenue, N.Y.C.
Mimosa 801-17th Ave, Nashville
Minaret 200 W. 57th St, N.Y.C.
Mindyl 624 S. Michigan, Chicago
Mingo 756 Seventh, N.Y.C.
Minit 6425 Hollywood Blvd., Hollywood
Miraj 3322 W. Peterson, Chicago
Miramar 6417 W. 84th., L.A., Cal.
Miss Marcie 15 W. 55th., N.Y.C.
Mission 7936 Santa Monica, L.A., Cal.
Missie 2428 S. Broad, Phila., Pa.
Missouri 1650 Broadway, N.Y.
Mist 108 E. 30th., N.Y.C.
Mitoma 468 W. 58 St., N.Y.C.
Mitti 104-20 Queens Blvd., Forest Hills, N.Y.
Miv 1650 B'way, N.Y.C.
Miyako 2186 5th Ave, N.Y.C.
Mobile 1626 No. Vine, Hollywood
Moccison 1637 Vista Del Mar, Hollywood
Modern 9317 W. Washington, Culver City, Cal.
Mohawk 2741 Shacklett Dr., Nashville, Tenn.
Mojo 2258 Monroe, Memphis, Tenn.
Monitor 1337 Washington, Boston, Mass.
Mono 4720 Forman, N. Hollywood
Monocle 507 Fifth, N.Y.C.
Montauk 1650 Broadway, N.Y.C.
Montclare 1800 N. Argle, Hollywood
Montecito Box 2471, Hollywood
Monterey 1114 N. Sweetzer, Hollywood
Monty 5209 Haverford, Phila., Pa.
Moomoo 119 W. 57th., N.Y.C.
Moon Mist 1697 Broadway, N.Y.C.
Moonbeam 1614 N. Argle, Hollywood
Moonchild 211 W. 53rd., N.Y.C.
Moonlight 9155 Sunset, Hollywood
Jose Morand 1619 Broadway, N.Y.C.
Morey 4724 W. Washington, L.A., Cal.
Morgan 1529 Pine, Phila., Pa.
Morgan-Shelley 226 Capitol Blvd., Nashville, Tenn.
Morkane 3906 Mary Ellen, Studio City, Calif.
Morning Sun 608 Fifth, N.Y.C.
Morro 1733 Broadway, N.Y.C.
Morton 565 Fifth, N.Y.C.
Moss Rose 806-16th. Ave. So., Nashville, Tenn.
Mother Bertha 440 E. 62nd, N.Y.C.
Motion 1631 Broadway, N.Y.C.
Mount Royal 1549 N. Vine, Hollywood
Mount Rushmore 1607 N. El Centro, Hollywood
Mountain City Dome Building, Chattanooga, Tenn.
Mountain 1595 Crossrds of World, Hollywood
Mundial 6710 Northing St. Houston, Texas
Munson 2 W. 45th., N.Y.C.
Muse 1256 So. Orange, Glendale, Cal.
Music Development 101 W. 55th., N.Y.C.
Music International 1619 Broadway, N.Y.C.
Music Maestro's 1674 Broadway, N.Y.C.
Music Mill 5880 Hollywood Blvd., Hollywood
Music Row 117 West 46 St, N.Y.C.
Music of Today 119 W. 57th., N.Y.C.
Music Products 1501 Broadway, N.Y.C.
Music World 6087 Sunset, Hollywood
Musicians 6087 Sunset, Hollywood
Musictime U.S.A. 9 Rockefeller Plaza, N.Y.C.
Musonic 458 Cornish Dr., Nashville, Tenn.

Nagy 785 West End Ave., N.Y.C.
Najac 1631 Broadway, N.Y.C.
Najo 5840 Second Blvd., Detroit, Mich.
Nam 511 Fifth Ave., N.Y.C.
Nanc0z 1270 Sixth, N.Y.C.
Narwood 40 E. 49th., N.Y.C.
Nash-Beau 888 Pearl St., Beaumont, Texas
Nasta 8497 Sunset, Hollywood
Natchez Trace 2911 Harlin Dr., Nashville, Tenn.
Nathan 1650 Broadway, N.Y.C.
Navajo 1800 N. Argle, Hollywood
Navarre 1721 Broadway, N.Y.C.
Near North 35 East Wacker Dr, Chicago
Neil 8566 Sunset, Hollywood
Herbert Nelson 250 W. 57th., N.Y.C.
Nestor 156 W. 44th., N.Y.C.
New Chamber 461 Sixth Ave, N.Y.C.
New Christy 1614 N. Argle, Hollywood
New Lyric 46 East Superior St, Chicago
New Era 322 W. 48th., N.Y.C.
New Hope 150 W. 58th., N.Y.C.
New Keys Box 507, Nashville, Tenn.
New Ventures 390 W. 57th., N.Y.C.
New Wave 1619 B'way, N.Y.C.

Bob Newhart 79 W. Monroe, Chicago
Newmark 1639 Broadway, N.Y.C.
Newroads 119 W. 57th., N.Y.C.
Niagara 320 W. 55, N.Y.C.

(Continued on next page)

BMI PUBLISHERS

Nibs 1639 Broadway, N.Y.C.
 Tom Neilsen 1416 N. New Hampshire
 Nicolet 328 East 58th St., N.Y.C.
 Nimny 205 W. 84th., N.Y.C.
 Nite-Life 2090 Seventh, N.Y.C.
 Nobil 150 W. 58th., N.Y.C.
 Nocturne 1674 Broadway N.Y.C.
 Nola Box 52287, New Orleans, La.
 Nole 720 N. Michigan, Chicago
 Nom 1631 Broadway, N.Y.C.
 Noma 1619 Broadway, N.Y.C.
 Non-Stop 19 East 76th St., N.Y.C.
 Nor Va Jak Music, Inc., 1813 W. Seventh,
 Clovis, N.M. and 50 West 57th St., N.Y.C.
 Norad 3510 Hampton, Nashville, Tenn.
 Norbay 185 Wabash, Chicago
 Nor-Cliff 521 Fifth, N.Y.C.
 Norlam 9 E. 40th., N.Y.C.
 Norles 1501 Broadway, N.Y.C.
 Norman 1353 N. Highland, Hollywood
 Norman-Leanord 442 W. 57th., N.Y.C.
 North Star 1936 University, St. Paul, Minn.
 Northeastern 1650 Broadway, N.Y.C.
 Nosruc 140 E. 7th., N.Y.C.
 Nottingham 6381 Hollywood Blvd., Hollywood
 Novel 419 Boylston St., Boston, Mass.
 Nu-Dey Musical 17823 Collins, Encino, Cal.
 Nubia 616 Exchange Building, Nashville
 Nuca 1697 B'way, N.Y.C.
 Nugget 1414 Commerce Title Bldg., Memphis,
 Tenn.
 Numart 6757 Hollywood Blvd., Hollywood
 Nu-Star 298 Brown, Nashville, Tenn.
 Nu-Way 1650 Broadway, N.Y.C.

Oak Route #2, Box 60, Elm City, N.C.
 Oakcrest 1126 Jeanette St., Abilene, Texas
 Oakhurst 366 No. Camden Dr., Beverly Hills,
 Cal.
 Oakwood 2809 West Linden Ave., Nashville,
 Tenn.
 Obie 1650 Broadway, N.Y.C.
 Obyte 175 Fifth, N.Y.C.
 Oceanic 58 W. 48th., N.Y.C.
 Odeon 200 W. 57th., N.Y.C.
 Odile 1607 No. El Centro, Hollywood, Cal.
 Off Beat 146 Seventh Ave., Nashville, Tenn.
 Ogram 247 West 72nd. St., N.Y.C.
 Okra 35 W 53, N.Y.C.
 Okun P.O. Box 2605, Hollywood, Cal.
 Olbert 1650 Broadway, N.Y.C.
 Old Beachcomber 6639 San Vicente, Compton,
 Cal.
 Old Judge 1458 Getwell, Memphis, Tenn
 Old Lyne 101 W. 55th., N.Y.C.
 Sy Oliver 400 Madison, N.Y.C.
 Olowola 664 West 163rd St., N.Y.C.
 Otto Norman Olsen 1239 Gordon, Hollywood,
 Cal.
 Omanid 1952 South Muskego, Milwaukee, Wis.
 Omni 817 16th Ave, Sq. Nashville
 Omnibus 50 W. 8th., N.Y.C.
 One O'Clock 225 W. 57th., N.Y.C.
 One, Two, Three 128 Thompson, N.Y.C.
 One-Way 1206 Sudekum Bldg., Nashville,
 Tenn.

Onko 6612 N. Lightfoot, Chicago, Ill.
 Opal 6308 Sunset Blvd., Los Angeles, Cal.
 Open Road P.O. Box 128, Madison, Tenn.
 Optimist 13325 Victory Blvd., Van Nuys, Cal.
 Opus 200 W. 57th., N.Y.C.
 Orange 18 E. 50th., N.Y.C.
 Orbey 8044 Winnemac Ave, Norridge, Ill.
 Orbit 4010 W. Olympic, L.A., Cal.
 Orchard Box 1408, G.P.O., N.Y.C.
 Ordell 1619 Broadway, N.Y.C.
 Origatunes 10337 East Beach, Bellflower, Cal.
 Original 1721 Broadway, N.Y.C.
 Orjae 6514 So. San Pedro St., L.A., Cal.
 Ormon 1258 Gordon St., Hollywood, Cal.
 Orpheus 2 Sickles, N.Y.C.
 Orquidia 928 Orme, Los Angeles, Cal.
 Ortega 9034 Sunset Blvd., Los Angeles, Cal.
 Orvin 534 W. 150th., N.Y.C.
 Osborne 2076 Union Ave., Memphis, Tenn.
 Oscar 745 Fifth, N.Y.C.
 Othello 365 West 20th., N.Y.C.
 Johnny Otis 1631 Broadway, N.Y.C.
 Outpost 6277 Selma Avenue, Hollywood, Cal.
 Oval 15 Central Park West, N.Y.C.
 Ovation 2019 St. Charles, New Orleans
 Overland 2 West 45th St., N.Y.C.
 Overture 119-33 147th, Jamaica, L.I., N.Y.
 Overture 428 Gretna Green, Los Angeles, Cal.
 Owaisa 14536 Roscoe, Panorama City, Cal.
 Owen P.O. Box 842, Bakersfield, Cal.
 Don Owens 319 Adams, Memphis, Tenn.
 Owl Music 32 West Randolph St., Chicago, Ill.
 Ozy 137 W 52, N.Y.C.

P & M 48 W. 53rd. St., N.Y.C.
 P-G 4648 S. Cottage Grove, Chicago, Ill.
 P.N.P. 1595 Broadway, N.Y.C.
 P.P.X. 565 Fifth Ave., N.Y.C.
 Paberne 756 7th. Ave., N.Y.C.
 Pace 117 W. 48, N.Y.C.
 Pacific Coast P.O. Box 38631, Hollywood, Cal.
 Pacific-International 16427 Harvard, Gardena,
 Cal.
 Padre 407 West 40th., St., N.Y.C.
 Padua 5004 Melrose Ave., Hollywood, Cal.
 Page 523 W. 6th., Los Angeles, Cal.
 Paget Time & Life Bldg., N.Y.C.
 Pagoda 6035 Le Doux Rd., Los Angeles, Cal.
 Painted 666 Fifth, N.Y.C.
 Pal 928 Western, Broad & Chestnut, Phila.,
 Pa.
 Palisades 11 West 60th St., N.Y.C.
 Palladium 6229 Sunset, Hollywood, Cal.
 Tommy Palm 85 Second, Brooklyn, N.Y.
 Palmer 5101 Matilija, Sherman Oaks, Cal.
 Palmira 1703 Jackson St., Phila., Pa.
 Palmira N.W. Cor. 8th & Fitzwater Sts.,
 Phila., Pa.
 Pam 1650 Broadway, N.Y.C.
 Pamasons 6022 Bay Parkway, Brooklyn, N.Y.
 Pamco 1501 Broadway, N.Y.C.
 Pamela 588 Alston, Memphis, Tenn.
 Pamlee 1323 S. Michigan, Chicago, Ill.
 Pamper 119 Two Mile Pike, P.O. Box 96,
 Goodlettsville, Tenn.
 Pan 242 N. Canon Drive, Beverly Hills, Cal.

Pandora (See Lois)
 Panfa 1757 N. Serrano, Hollywood, Cal.
 Pan-World 1543 S. Canfield Dr., Los Angeles,
 Cal.
 Papaleo 1639 Broadway, N.Y.C.
 Paper 8462 Sunset Blvd, Los Angeles
 Parade 120 South Valley, Burbank, Cal.
 Param 1501 B'way, N.Y.C.
 Parasol 3011 Beach 40th B'klyn., N.Y.
 Park 351 East 53th., N.Y.C.
 Barry Parker 1710 Ave., Brooklyn, N.Y.
 Charlie Parker 8 East 48th., N.Y.C.
 Johnny Parker 15 W. 84th., N.Y.C.
 Park-Lane 2043 Wellington, Westbury, N.Y.
 Gene Parson 7023 Oxford, Oaklawn, Ill.
 Pasadena 148 N. Pasadena, Pasadena, Cal.
 Pasca National Bank Bldg., Market St.,
 Phila., Pa.
 Paskal 7561 Waring, Los Angeles, Cal.
 Paso 100 No. La Salle, Chicago, Ill.
 Pastel 112-25 34th., Corona, L.I.,
 Pastor 1790 Broadway, N.Y.C.
 Pat 2 Wayland Rd., Plainview, N.Y.
 Patmar 6233 Wilshire, Los Angeles, Cal.
 Patone 237 Chestnut St., Westville, N.J.
 Patricia 1631 Broadway, N.Y.C.
 Patsy Ann 224 West 49th., N.Y.C.
 Pattern 16 South Broad, Phila., Pa.
 Jack Patton 1924 W. 7, Hollywood, Cal.
 Paty 618 So. Western, Los Angeles, Cal.
 Paula 5420 Corbin, Tarzana, Cal.
 Paulette South Rd., Harrison, N.Y.
 Paulus 654-660 Chelsea, Memphis, Tenn.
 Paul-Marc 1607 North El Centro, H'wood, Cal.
 Paulric 6623 Ridge, Brooklyn, N.Y.
 Pawnee 137 Riverside, N.Y.C.
 Pawwin 1619 Broadway, N.Y.C.
 Peach Box 115, Madison, Tenn.
 Peanuts 150 West 55th., N.Y.C.
 Peargay 11622 Canton Pl. Studio City, Calif.
 Pearl 1619 Broadway, N.Y.C.
 Pearlford 4163 Central Ave., Los Angeles, Cal.
 Pearson 729 S. Western, Los Angeles, Cal.
 Pecke 1220 N. Broad, Phila., Pa.
 Peer Int'l. 1619 Broadway, N.Y.C.
 Peerless 3547 Dahlia, Los Angeles, Cal.
 Pegasus 1607 North El Centro, Hollywood, Cal.
 Pel Music 612 Patterson, Chicago, Ill.
 Pelican 912 Front St., P.O. Box 444, Morgan
 City, La.
 Pelton 1650 Broadway, N.Y.C.
 Pemora 1619 Broadway, N.Y.C.
 Pen 507 Fifth Ave., N.Y.C.
 Pendarvis P.O. Box 41, Old Town, Fla.
 Pendulum 499 N. Canon, Beverly Hills, Cal.
 Penguin 210 W. 79th., N.Y.C.
 William Penn 150 W. 55th St, N.Y.C.
 Pennjay 3476 Amber, Phila., Pa.
 Penny 130 So. 4th., St., Las Vegas, Nev.
 Penobscot 250 Prospect, Revere, Mass.
 Penrose 5911 South Broadway, L.A., Cal.
 Pep 5452 Pelleur St., Compton 2, Cal.
 Perception 524 Poinsettia Place, L.A., Cal.

Perdue & Perdue 1735 Seward 3D, Detroit,
 Mich.
 Perfection 1429 Hawthorne, Pittsburgh, Pa.
 Peri-Lee 22 W. 670 Sidney, Glen Ellyn, Ill.
 Periscope 89 Hollingsworth Boston, Mass.
 Pernie 11 East Delaware Pl. Chicago
 Perry P.O. Box 131, 500 Adams, Vidalia, Ga.
 Personality 1055 N. El Centro, L.A., Cal.
 Petal Pat 128 E. 65th., N.Y.C.
 C. F. Peters 373 Park Ave., S., N.Y.C.
 Petko 1141 North Highland Ave., H'wood, Cal.
 Petone 25 W. 56, N.Y.C.
 Max Pfeffer 45 W. 45th St., N.Y.C.
 Philadelphia 550 Fifth Ave., N.Y.C.
 Philaine 1628 W., Los Angeles, Cal.
 Phoebe 1170 Broadway, N.Y.C.
 Phoenix 50 West 57th., N.Y.C.
 Piccadilly 756 Seventh, N.Y.C.
 Pickford 107 W. 43rd., St., N.Y.C.
 Pico 1332 S. Flower, L.A., Cal.
 Picturetone 1650 Broadway, N.Y.C.
 Hilda Piehl 54 W. Randolph, Chicago, Ill.
 Pierre 2659 Milwaukee, Chicago, Ill.
 Pinebrook 1650 Broadway, N.Y.C.
 Pine Knob 45 W. 56, N.Y.C.
 Pinelawn 756 Seventh Ave., N.Y.C.
 Pink Lady 6235 N. Lowell, Chicago, Ill.
 Pinpoint Crestview, Nashville, Ind.
 Pioneer 8665 Wilshire, Beverly Hills, Cal.
 Pirouette 2222 So. Western, Los Angeles, Cal.
 Pitfield See January
 P.S. Pitts, 1415 E. 18th. St., Los Angeles, Cal.
 Pixie 123 Toluca Lake, Hollywood, Cal.
 Place 565 Fifth, N.Y.C.
 Plainview 119 West 57th. St., N.Y.C.
 Platter 1650 Broadway, N.Y.C.
 Plaudit 1841 S.W. 29th Miami, Fla.
 Play 1501 Broadway, N.Y.C.
 Playette 401 West 42nd, N.Y.C.
 Playmate 616 Laverne Wilmette, Ill.
 Plav-Mor 52-87 79th Elmhurst, L.I., N.Y.
 Playnote 306 51st, N.Y.C.
 Playrite 201 W. 49th, N.Y.C.
 Pleasant Valley 14143 Chandler Van Nuys, Cal.
 Pleasure 2936 Baker St., Baker, Ore.
 Plectrum 6087 Sunset Hollywood, Cal.
 Neely Plumb 6463 Firmament Van Nuys, Cal.
 Pluto 1518 Wilton Pl. Los Angeles, Cal.
 Podium 10935 Mc Vine Sunland, Cal.
 Podler 1104 Roscomare Los Angeles, Cal.
 Pokvan 150 W. 55th St, N.Y.C.
 Poochum 4515 W. 29th St, Los Angeles
 Poodle 161 W 54 N.Y.C.
 Practical 538 So. Berendo, #4, Los Angeles
 Potomac 2103 Penn. Ave. N.W., Wash. D.C.
 Power X Music 1650 Broadway, N.Y.C.
 John Lowell Pratt 232 Madison, N.Y.C.
 Premier Albums 356 West 40th St., N.Y.C.
 Premium 1600-10 S. LaSalle Chicago, Ill.
 Elvis Presley 1619 Broadway, N.Y.C.
 Press 827 Thomas Memphis, Tenn.
 Prestige 203 S. Washington Bergenfield, N.J.
 Presto 6223 Selma Ave. Hollywood, Cal.
 Pretty 611 South 11th Las Vegas, Nev.

(Continued On Next Page)

THE CONSISTENT "CHART SOUND" OF THE **RAY CHARLES SINGERS**

Starting their 14th year on the Perry Como TV Show



JUST RELEASED
 AND THEIR BEST YET!

"SONGS FOR LATIN LOVERS"

Command RS 886



Exclusively: **COMMAND RECORDS**

BMI PUBLISHERS

Price & Associates 48 W. 138th St., N.Y.C.
Henry Price 2058 Watsonia Terrace Hollywood, Cal.
Frigan 608 Fifth Ave., N.Y.C.
Primary 1501 Broadway, N.Y.C.
Prince 111-35 76th Forest Hills, N.Y.
Princeton 4402 Vineland N. Hollywood, Cal.
Prin-El 2639 East Broadway Long Beach, Cal.
Pringle 1125 Sarah St., Hollywood, Cal.
Prior 129 Front St., N.Y.C.
Prism 6920 Sunset Hollywood, Cal.
Pritchett P.O. Box 2908 Hollywood, Cal.
Private Library 35 West 53rd St., N.Y.C.
Prix 235 46th St., N.Y.C.
Pro Musica 1215 Fifth Ave., N.Y.C.
Process 114 N. Front Franklin, Pa.
Profile 218 W. 47th N.Y.C.
Progressive 1619 Broadway, N.Y.C.
Prolific 841 E. 25th Los Angeles, Cal.
Prologue 15 Park Row, N.Y.C.
Promar 1842 Dudley Phila., Pa.
Promotions Of Memphis 1490 Mink Memphis, Tenn.
Prompt 5835 So. San Pedro Los Angeles, Cal.
Prop-er 833 E. Parkway Brooklyn, N.Y.
Prosper 768 Broad St., Newark 1, N.J.
Proven 1585 Broadway, N.Y.C.
Prytania P.O. Box 5053, Chicago, Ill.
Pub 1650 Broadway, N.Y.C.
Pulse 1360 North Lakeshore Chicago, Ill.
Pure Gold 297 N. Main Memphis, Tenn.
Pure 185 N. Wabash Chicago, Ill.
Purple Flamingo 220 W. 13th St., N.Y.C.

Raleigh 345 W. 58th N.Y.C.
Ra-Leen 3021 Carmona Los Angeles, Cal.
Italkelaw 4155 Mary Ellen Ave., N. Hollywood, Cal.
Ralla 12 Warren St., N.Y.C.
Ram 250 E. 116th N.Y.C.
Rama 650 N. Bronson Ave., Hollywood, Cal.
Rambled 1320 Vine St., Phila., Pa.
Ramitary 1740 B'way, N.Y.C.
Rammus Box 164 Mc Allen, Texas
Rampart 902 Pine Winnetka, Ill.
Al Randolph 2588 Seventh N.Y.C.
Random 9350 Wilshire Beverly Hills, Cal.
Rangel 505 W. Commerce San Antonio, Texas
Ranger-Lee P.O. Box 322 N. Hollywood, Cal.
Rapture 2943 Western Los Angeles, Cal.
Rare 1716 Tisinger Dallas, Texas
Raskind 155 W. 46th N.Y.C.
Rave 1253 N. Laurel Los Angeles, Cal.
Raybird 49 W. 57th N.Y.C.
Rawson 4712 S. Penn., Okla. City, Okla.
Ray-Dor 1153 1/2 N. Edgemont Los Angeles, Cal.
Ray-Gee 1650 Broadway, N.Y.C.
Raymar 345 W. 58th N.Y.C.
Raymon 631 No. Morada West Covina, Cal.
Raytrue 9503 Broadmoor Pleasanton, Cal.
Rayven 1650 Broadway, N.Y.C.
Reba
Reben 60 E. 42nd Room 4106 N.Y.C.
Rebus 335 West 11th St., N.Y.C.
Recco 320 E. 54th St., N.Y.C.
Robert Recker (E.B. Marks)
Recordo 6359 Selma Hollywood, Cal.
Red Ball 3914 Hamilton Fort Worth, Texas
Red River 1001 N. Lincoln Burbank, Cal.
R-d Seal 801 17 Ave. S., Nashville, Tenn.
Red Stick 100 Spain P.O. Box 2306 Baton Rouge, La.
Red, White & Blue P.O. Box 5314 San Diego, Cal.
Reddev 801 N. Labrea, Los Angeles, Cal.
Redheads 119 W. 57th St., N.Y.C.
Redstone 9163 Sunset Blvd. Los Angeles, Cal.
Reed's 54 W. 116th St., N.Y.C.
Regal 1342 No. Orange Hollywood, Cal.
Regency 1040 N. Las Palmas Hollywood, Cal.
Regent 1619 Broadway, N.Y.C.
Regina 507 Fifth N.Y.C.
Regnis 201 W. 77th N.Y.C.
Rego Park 61-15 98 St., Rego Park, N.Y.
Rehml 433 Savier Knoxville, Tenn.
Herh Reis 1619 Broadway, N.Y.C.
Release 450 W. 147th N.Y.C.
Rell-Tom-Pol 1650 Broadway, N.Y.C.
Remarque 180 W. 58th N.Y.C.
Rembrandt 59 E. 54th N.Y.C.
Renaldo's 46 W. 116th N.Y.C.
Renato 4622 S. Mozart, Chicago
Rencoll 18617 St. Aubin Detroit, Mich.
Renda 3708 No. Seventh Phoenix, Ariz.
Anthony Renfro 1895 W. 22nd St., Los Angeles, Cal.
Reno 180 Bay 32 Brooklyn, N.Y.
Renown P.O. Box 1674, Durham, N.C.
Renraw 21617 Reynolds Torrance, Cal.
Renrel 3351 N. Green Bay, Milwaukee, Wis.
Rensark 1887 Bay Atlantic Beach, N.Y.
Repeat 1050 S. Gramercy Los Angeles, Cal.
Republic 1619 Broadway, N.Y.C.
Res-erve 6522 Tanglewood Seven Hills, Ohio
Retta 9820 Yoakum Beverly Hills, Cal.
G.M. Reuss 630 N. Columbia Naperville, Ill.
Revilo 199 Botsford Hempstead, N.Y.
George W. Rex 1107 Commerce Tacoma, Wash.
Rexford 408 North Rodeo Beverly Hills, Cal.
Rey 478 Central Park W., N.Y.C.
Rey Reid 1697 Broadway, N.Y.C.
Reynolds & Andrews 1816 W. Adams Los Angeles, Cal.

Rhodes 8715 W. Third Hollywood, Cal.
Rhombus P.O. Box 47 Hollywood, Cal.
Rhoton, 439 Brewer, Nashville, Tenn.
Rhythmetime 226 S. Beverly, Beverly Hills, Cal.
Rhythm Int'l. 451 W. 47th N.Y.C.
Rhythm Tamers 21834 Grace Torrance, Cal.
Rhythms Of West 11 Palm Circle Rd., Redwood City, Cal.
Mareno Ricci 934 Tree Phila., Pa.
Rice Mill 1405 Locust Phila., Pa.
Scott P.O. Box 6 Belen, N.M.
Charles Rich 639 Madison, Memphis, Tenn.
Bob Richards 116 W. 45, N.Y.C.
Safari 12340 So. Curson, Los Angeles, Cal.
Richben 1650 Broadway, N.Y.C.
Richcraft 2314 63rd Brooklyn, N.Y.
Richfield 206 12th Ave. San Francisco, Cal.
Richtone Box 6081, Dallas, Texas
Ricky 1501 Broadway, N.Y.C.
Ric-O-Lac 3330 N. Lake Shore Dr., Chicago, Ill.
G. Ricordi 16 W. 61st N.Y.C.
Riddle 4819 Gentry N. Hollywood, Cal.
Ridge 850 Seventh N.Y.C.
Ridgefield 1619 Broadway, N.Y.C.
Ridgegaw 6087 Sunset Hollywood, Cal.
Riff-Time 2706 Ford Brooklyn, N.Y.
Rigmor 154 W. 106th N.Y.C.
Rikpage 7417 Melrose Los Angeles 46, Cal.
Riley 400 Madison N.Y.C.
Rim 1293 Dean Brooklyn, N.Y.
Gene Ring Bank Of Galesburg Bldg. Galesburg, Ill.
Charles Rinker 1610 N. Argyle Hollywood, Cal.
Rinky Dink 1726 N. Occidental Los Angeles, Cal.
Rio 28 E. 10th N.Y.C.
Ripley 1776 Broadway, N.Y.C.
Rittenhouse 1617 North Broad Phila., Pa.
TexRiHev 6124 Selma Ave., H'wood, Calif.
Rival 6240 A. Wilcox Bell, Cal.
River 1323 So. Michigan Ave., Chicago, Ill.
Riverdale 145 Linn Yonkers, N.Y.
Roadside 151 East 49th St., N.Y.C.
Ro-An 535 N.E. 113th St., Miami, Fla.
Roar 2125 N. Commonwealth Hollywood, Cal.
Rohand 165 W. 46th N.Y.C.
Rob-Ann 254 W. 54th N.Y.C.
Robbie P.O. Box 117 Westminster, Cal.
Robin Hood 5916 Carleton Way, Los Angeles, Cal.
Floyd Robinson 154 Eighth N. Nashville, Tenn.
Robinson 34-36 E. 32nd N.Y.C.
Robinsons 180 W. 58th N.Y.C.
Roblar 8400 Sunset Hollywood, Cal.
Robot 2095 San Jacinto Beaumont, Texas
Robyn Renee 2016 Terrace Nashville, Tenn.
Rock Masters 56 W. 45th N.Y.C.
Rock 5244 Whitsett N. Hollywood, Cal.
Rock 'N Roll 707 S. 55th Phila., Pa.
Rockaway 1631 Broadway, N.Y.C.
Rockford 149 W. 48th N.Y.C.
Rockingham 12198 Ventura Studio City, Cal.

Rockland 2 W. 45th N.Y.C.
Rockville 1619 Broadway, N.Y.C.
Rocky Hill 3435 Alta Vista Dr., Chattanooga, Tenn.
Roc-Mar 193 Bay 40th Brooklyn, N.Y.
F.W. Rode P.O. Box 430 Santa Cruz, Cal.
Rodel 2615 Woodhill Cleveland, Ohio
Gene Rodgers 134 W. 53rd N.Y.C.
Rodney 7619 Sunset Hollywood, Cal.
Roe 60 E. Bellevue, Chicago, Ill.
Roeday 748 S. 10th Newark, N.J.
Rogers & Van Buren P.O. Box 64431, Los Angeles, Cal.
Ro-Gor 5135 St. Antoine Detroit, Mich.
Rojo 255 Crooks Clifton, N.J.
Rolling Hills 2311 Gentry Houston, Texas
Rollins 1619 Broadway, N.Y.C.
Rolly 1692 Madison Memphis, Tenn.
Romance 154 W. 54th N.Y.C.
Rome Rox 31 Sutton Place S., N.Y.C.
Romeo 1047 1/2 W. 52nd Los Angeles, Cal.
Rom 333 W. 56th N.Y.C.
Romola 949 N. Clark Los Angeles, Cal.
Ron P.O. Box 866 New Orleans 12, La.
Rona 1739 De Camp Beverly Hills, Cal.
Rondeau 254 W. 49th N.Y.C.
Rondell 6515 Sunset Los Angeles, Cal.
Rondo P.O. Box 2367 Hollywood, Cal.
Rondon 1721 Broadway, N.Y.C.
Ronlor 461 Eighth Ave., N.Y.C.
Rook 119 W. 57th St., N.Y.C.
Room Seven 6365 Selma Ave., Hollywood, Cal.
Roosevelt 1650 Broadway, N.Y.C.
Rorrie 6061 Hollywood, Hollywood, Cal.
Ror-Ron 2333 Marbury Pittsburgh, Pa.
Maria Rosa 7021 Hollywood, Hollywood, Cal.
Rosarch 119 W. 57th N.Y.C.
George F. Rosche 337 W. Madison St., Chicago, Ill.
Fred Rose 2510 Franklin Nashville, Tenn.
Martin Rose 123 W. Madison Chicago, Ill.
Rose City 150 W. 55th N.Y.C.
Rose Hill 150 W. 55th N.Y.C.
David Rosen P.O. Box 94 Bloom Hall, Pa.
Rosenberg 414 North Vista Los Angeles, Cal.
Rosewood 254 W. 49th N.Y.C.
Leo Ross 443 W. 50th N.Y.C.
Ross 9222 Allwood Houston, Texas
E. Rossi 127 Mulberry, N.Y.C.
Rossmore 6241 Camellia No. Hollywood, Cal.
Rossongs 1650 Broadway, N.Y.C.
Rotine 2835 West Los Angeles, Cal.
Rouze 218 W. 49th N.Y.C.
Rox 1619 Broadway, N.Y.C.
Royal American 1200 Howard Bellaire, Texas
Royal Crest 3919 Roxanne Los Angeles, Cal.
Royal Crown 160 W. 46th N.Y.C.
Rozell 605 S. Normandie Los Angeles, Cal.
Rozzo 6087 Sunset Hollywood, Cal.
Mark Rubens 1687 Broadway, N.Y.C.
Rubill 295 Madison, N.Y.C.
Rudder 15 J. Morrissey Teaneck, N.J.
Rue 7436 Genesta Van Nuys, Cal.
Rugby 1343 S. Michigan Chicago, Ill.
Rujantar 5231 Biloxi No. Hollywood, Cal.
Rumhalero 1619 Broadway, N.Y.C.
Rumson 1426 N. Beechwood, Hollywood, Cal.
Rupert Music 1601 No. Gower, Hollywood, Cal.
Rush 756 Seventh N.Y.C.
Russell 1631 Broadway, N.Y.C.
Russer 1630 Broadway, N.Y.C.
Russ-Dale 155 W. 46th N.Y.C.
Willard Russell 2130 Feger Fresno, Cal.
Russ-Hix 121 Bank N.Y.C.
Rusthoi Gospel P.O. Box 647, Pasadena, Cal.
Rustic 5454 Mesmer Culver City, Cal.
Ruth 3437A No. 24th Milwaukee, Wis.
Ryerson 154 W. 14th N.Y.C.

Quan P.O. Box 42115 Los Angeles, Cal.
Quasimodo P.O. Box 2122, Williamsburg, Va.
Queensbury 1631 Broadway, N.Y.C.
Quest 9 Lorraine New City, N.Y.
Quilted 1755 York Memphis, Tenn.
Quinn 5100 Calenda Woodland Hills, Cal.
Quintet 1619 Broadway, N.Y.C.

R.A.O. 5420 Melrose Hollywood, Cal.
R & R 214 Tower Life Bldg., San Antonio, Texas
R & S 137-59 70th Flushing, N.Y.
R & T 2341 18th Vero Beach, Fla.
R.E.T.J. 121 E. Olive Monrovia, Cal.
R.F.T. 150 W. 46th St., N.Y.C.
R.G. 45 W. 45th N.Y.C.
R.G.A. 410 1/2 N. Palm Beverly Hills, Cal.
R.P.D. 100 W. 42nd N.Y.C.
RSVP 1650 Broadway, N.Y.C.
R-T (See Lois)
RTD 537 Dunn Pittsburgh, Pa.
RTL 1962 West 29th Los Angeles, Cal.
R-V 6600 N. Broad St., Phila., Pa.
Rachel 8665 Wilshire Beverly Hills, Cal.
Radcliffe 855 Treat San Francisco 10, Cal.
Radiant 185 N. Wabash Chicago, Ill.
Radio Active P.O. Box 558 N. Hollywood, Cal.
Radioir 150 W. 55th N.Y.C.
Radon 173 W. Madison Chicago, Ill.
Ragmar 41 W. 72, N.Y.C.
Rags 450 W. 24th N.Y.C.
Rainbow 1975 Davidson, N.Y.C.

SAAB 850 Seventh Ave. N.Y.C.
S & H 5143 W. 58th Pl., Los Angeles, Cal.
S & S (See Lois)
S and W P.O. Box 135, Riverside, Cal.
SG 711 Fifth Ave., N.Y.C.
S-G 90 Charles, N.Y.C.
S N M 6940 Bay Miami Beach, Fla.
S-P-R 1619 Broadway, N.Y.C.
Sabra 109 South Flores Los Angeles, Cal.
Sacramento 160 W. 46th N.Y.C.
Sacred 1619 Broadway, N.Y.C.
Sa-Day 247 W. 72nd N.Y.C.
Sadie 505 Fifth N.Y.C.
Safari 1234 N. June Hollywood, Cal.
Sag Harbor 1619 Broadway, N.Y.C.
Sagamore 1650 Broadway, N.Y.C.
Saginaw 1619 Riverside Nashville, Tenn.
Sahara 3570 Atlantic Long Beach, Cal.
Saima 8831 Sunset Los Angeles, Cal.
St. Lawrence 6087 Sunset Hollywood, Cal.
St. Louis 1619 Broadway, N.Y.C.
Salaam 4659 S. Drexel Chicago, Ill.
Sally 101 W. 55th N.Y.C.
Salm 1619 Broadway, N.Y.C.
Sam 96 Perry N.Y.C.
Sambek 2928 Prospect Cleveland, Ohio
Sambra 145 W. 47th N.Y.C.
Sampson 155 E. 24th N.Y.C.
San Juan 1650 Broadway, N.Y.C.
San Remo 853 Seventh N.Y.C.
Sanada 1631 B'way, N.Y.C.
Sanama 8601 Lone Star Rd., Jacksonville, Fla.
Sanco 1617 El Centro Hollywood, Cal.
Sand & Surf 612 15th Belmar, N.J.
San-Del 410 So. Michigan Ave., Chicago, Ill.
L. O. Sanderson 1619 Broadway, N.Y.C.
Sandette P.O. Box 664 Knoxville, Tenn.
Sandle 229 W. 52, N.Y.C.
Sandra 297 N. Main Memphis, Tenn.
Sandusky 12th & Walnut Bldg., Kansas City, Mo.
Sanford 506 Seventh Buffalo, N.Y.
Sanga 200 W. 57th N.Y.C.
Santo Box 433 Memphis, Tenn.
Sanwood 10 W. 74th St., N.Y.C.
Sapphire 533 Canal New Orleans, La.
Saracen 1607 North El Centro Hollywood, Cal.
Saran 2631 Fonville Dallas, Texas
Saratoxa 150 W. 55th N.Y.C.
Sardonvix 2648 Hillger Detroit 14, Mich.
Sark Music 1270 Sixth St., Memphis, Tenn.
Sar-Lib 107 Beale St., Memphis, Tenn.
Art Satherley 3507 Landa Los Angeles, Cal.
Saturday 1841 B'way, N.Y.C.
Satum 1650 Broadway, N.Y.C.
Satyr 3611 Buena Park Studio City, Cal.
Sausalito 608 Fifth Ave., N.Y.C.
Saxon 1697 Broadway, N.Y.C.
Scale 120 E. 56th St., N.Y.C.
Scarlet 307 South Wahash Chicago, Ill.
Peter Schaeffer's 756 Seventh N.Y.C.
Scherer 1619 Broadway, N.Y.C.
Max Schooner 6114 W. Vernor Highway, Detroit, Mich.

Schoppe 2942 Longwood Jacksonville, Fla.
Schulman 2643 S. 3rd St., Phila., Pa.
Wally Schuster 1650 Broadway, N.Y.C.
Scope 157 W. 57th St., N.Y.C.
Score 345 W. 53th St., N.Y.C.
Scorpio 6535 Wilshire Los Angeles, Cal.
Jay Scott 2200 N. Glenoaks Burbank, Cal.
Sculptone 119 W. 57th St., N.Y.C.
Sea Of Tunes 3701 W. 119th Hawthorne, Calif.
Sea-Bee 2531 W. Broadway P.O. Box 24 Louisville, Ky.
Seahreeze 2733 Kensington Phila., Pa.
Sea-Lark 25 West 56th St., N.Y.C.
Seaman 55 Liberty St., N.Y.C.
Sebastian 25 E. 67th St., N.Y.C.
Second Sound 1650 Broadway, N.Y.C.
Secor 1841 Broadway, N.Y.C.
Seelie 79 W. Monroe St., Chicago 3, Ill.
Seemac 119 W. 57th St., N.Y.C.
Dan Segal 915 Second N.Y.C.
Segario 270 W. 123rd, N.Y.C.
Segno 9729 Granger Garfield Hgts., O.
Selbourn 630 Lenox Ave., N.Y.C.
Paul Selden 850 W. 55th N.Y.C.
Sella 3236 Clarksville Highway Nashville, Tenn.
Sellstar 2110 N. Main Fort Worth, Texas
Selma 1650 Broadway, N.Y.C.
Semprini 1619 Broadway, N.Y.C.
Senator 210 W. 55th N.Y.C.
Sencha 720 Riverside, N.Y.C.
Sendme 1154 N. Wilton Los Angeles, Cal.
Senut 56 W. 45th St., N.Y.C.
Sepulveda 390 S. Hauser Blvd., Los Angeles, Cal.
Sequoia 224 W. 49th N.Y.C.
Serenade 1608 Hillhurst Los Angeles, Cal.
Serenidity 640 Fifth Ave., N.Y.C.
Session 1650 Broadway, N.Y.C.
Seven Seas P.O. Box 564 Nashville, Tenn.
Seven-Eleven 666 Fifth N.Y.C.
Seven-Teen 17 Ellis St., Lincoln Park, N.J.
Seventh Ave. 1650 Broadway, N.Y.C.
Seventy Second 306 E. 72nd N.Y.C.
Sewell 411 West End N.Y.C.
Sexton 5308 Laurel Canyon N. Hollywood, Cal.
Seymor Co. 119 57th N.Y.C.
Shac 109 W. 42nd N.Y.C.
Shadows 1619 Broadway, N.Y.C.
Shag 1861 W. Adams Los Angeles, Cal.
Shaggy 185 N. Wabash Chicago, Ill.
Sha-Lee's 1578 Adelia Place N.W. Atlanta, Ga.
Shalom 119 West 57th St., N.Y.C.
Shane 1141 S. Beverly Los Angeles, Cal.
Shannon 185 N. Wabash Chicago, Ill.
Sharolyn 915 North Clark Los Angeles, Cal.
Shasta P.O. Box 5203, Phoenix, Ariz.
Shat-Shep 7215 Hillside Hollywood, Cal.
Herman Shavers 5419 S. Michigan Chicago, Ill.
C. Shaw 1674 Broadway, N.Y.C.
Shaw Music 19 E. 48th N.Y.C.
Shaysee 1631 Broadway, N.Y.C.
Shealy 240 W. 55th N.Y.C.
Shelfield 666 Fifth N.Y.C.
Vernon Shelby P.O. Box 423 Jacksonville, N.C.
Sheldon-Mitchel 28 W. 38th N.Y.C.
Shell 4333 Bakman N. Hollywood, Cal.
Shelros 250 S. Broad St., Philadelphia, Pa.
Shenan 13013 Venice Los Angeles, Cal.
Jean Shepard 234 W. 48th N.Y.C.
Shepan P.O. Box 32114 Cincinnati, O.
Sheplev 150 W. 55th N.Y.C.
Shepmike 8961 Sunset Hollywood, Cal.
Sherco 280 Riverside Dr., N.Y.C.
Sherbourne 8745 Sunset Hollywood, Cal.
Sheridan 1650 Broadway, N.Y.C.
Sherlyn 495 S.E. 10th Court Hialeah, Fla.
Shermack 1650 Broadway, N.Y.C.
Sherman 1606 Argyle Hollywood, Cal.
Sherod 802 Linden Memphis, Tenn.
Sherrylvale 6124 Selma Ave. Hollywood
Shidel 1740 Broadway, N.Y.C.
Shields 54 W. Randolph Chicago, Ill.
J. Shink 729 Seventh N.Y.C.
Shirgus 5250 Appian Way Long Beach, Cal.
Shoe 1741 Market Oakland, Cal.
Shoe-String 1619 Broadway, N.Y.C.
Shorn 1619 Broadway, N.Y.C.
Short 101 W. 55th N.Y.C.
Show Music 1619 Broadway, N.Y.C.
Shuggie 2077 So. Harvard Los Angeles, Cal.
Shuler 607 Lauricella New Orleans, La.
Shumac 224 Canon Beverly Hills, Cal.
Albert Shutt 1333 Kansas Topeka, Kan.
Shwae 501 N. Sycamore Los Angeles, Cal.
Sid-Lee 756 Seventh N.Y.C.
Sidney 239 Central Park W., N.Y.C.
Siegf 7825 Ranchito Panorama City, Cal.
Siegfried-Charles 357 W. 55th N.Y.C.
Sierra 12824 Indianapolis Los Angeles, Cal.
Signal 210 S. 95th Petersburg, Ind.
Signature 4155 Mary Ellen N. Hollywood, Cal.
Signal 1674 Broadway, N.Y.C.
Sikorski 250 W. 57th N.Y.C.
Sildar 150 W. 55th N.Y.C.
Silken-Satin 155 W. 46th N.Y.C.
Silmo 13618 Addison Sherman Oaks, Cal.
Silver Screen 152 W. 49th N.Y.C.
Silver Tone 213 East 6th Austin, Texas
Silverbell Music 215 E. 68 St., N.Y.C.
Silyn Music 1821 De Loz Hollywood, Cal.
Simco 1630 Broadway, N.Y.C.
Simeck 457 W. 54th N.Y.C.
Simon House 250 W. 57th N.Y.C.
Simon-Jackson 6920 Sunset Hollywood, Cal.
Simplicity 1912 W. 138th Compton, Cal.
Sinclair 745 Fifth N.Y.C.
Singoey 1650 Broadway, N.Y.C.
Murray Singer 1674 Broadway, N.Y.C.
Singleton 1650 Broadway, N.Y.C.
Singmo 916 Kearney St. San Francisco, Cal.
Singular 250 S. Broad Phila., Pa.
Sir Music 4861 Fulton Sherman Oaks, Cal.
Siran 5840 Second Blvd., Detroit, Mich.
Sitma 365 W. 125th N.Y.C.
Sito 1619 Broadway, N.Y.C.
Sixty Six 660 N. Broad Phila., Pa.
Jimmie Skinner P.O. Box 493 Cincinnati, O.
Skinton 14958 Ardmore Ave. Detroit
Skudrink 5417 Fleet Cleveland, O.
Skylark P.O. Box 2837 Dallas, Texas
Skyrocket 342 E. 9th N.Y.C.
Skyway Box 133 Hollywood, Cal.
Slag 1072-5 Lynch Jackson, Miss.
Arthur Slater 1100 Glendale Los Angeles, Cal.
Slo-Motion 161 Fifth Bethpage, L.I., N.Y.
Slotkin 209 Glen Arbor Havertown, Pa.
Small-Loft 260 W. 72nd N.Y.C.
Smart 54 Wall Metuchen, N.J.
Smash 313 Pecan Dr., Monroe, La.

**34 YEARS SPECIALIZING
IN RECORDING SONGS
AND DANCES OF
23 NATIONALITIES**

The Best Selling Labels
of this Type of Music
"Colonial" and "Standard"
LP's
Monaural and Stereo

All Recordings Made
Under Personal
Supervision of
Tetos Demetriades

Ask for Our General Catalog
Containing the Following:

- CZECHOSLOVAKIAN
- FINNISH
- GERMAN
- GREEK
- HUNGARIAN
- IRISH
- ITALIAN
- JAPANESE
- JEWISH
- LATIN AMERICAN
- LEBANESE
- LITHUANIAN
- NORWEGIAN
- POLISH
- PORTUGUESE
- RUSSIAN
- SCANDINAVIAN
- DANCES
- SPANISH
- SWEDISH
- SYRIAN
- TURKISH
- UKRAINIAN
- YUGOSLAVIAN
- ACCORDION MUSIC
- CONTINENTAL MUSIC

**STANDARD
PHONO CORP.**

163 West 23rd Street
New York 11, N. Y.
Phone: CH 2-0880

BMI PUBLISHERS

Harrison Smith 254 New York Brooklyn, N.Y.
 Solidarity 12254 Montana Los Angeles, Cal.
 Some 511 Fifth N.Y.C.
 Somerset 1617 El Centro Hollywood, Cal.
 Sonark 1606 North Argyle Hollywood, Cal.
 Sonata 554 Fifth N.Y.C.
 Song Craft 8564 Hillside Los Angeles, Cal.
 Sonny Smith 1544 W. York Philadelphia, Pa.
 Snapper 1631 Broadway, N.Y.C.
 Snaive 1697 Broadway, N.Y.C.
 Snowflake Sound 410 Main St., W Orange, N.J.
 Hank Snow 1619 Broadway, N.Y.C.
 Rosina Soback 210 W. 7th Los Angeles, Cal.
 Sobel 1 East 28th St., N.Y.C.
 Society Of Jewish Composers, Publishers And
 Songwriters 54 Second N.Y.C.
 Soland Music P.O. Box 78243 Los Angeles, Cal.
 Songbird P.O. Box 25133 Los Angeles, Cal.
 Song-Ranch P.O. Box 287, Hollywood, Cal.
 Songs Of Spain 38 E. 57th N.Y.C.
 Songs Of The Country 245 W. 51st N.Y.C.
 Sonlo (See Lois)
 Sonnet 3237 N.W. 47th Oklahoma City 12,
 Okla.
 Sonny Boy, 1616 Argyle, Hollywood
 Sophisticate 1619 Broadway, N.Y.C.
 Sorority Fraternity 12 W. 117th St., N.Y.C.
 Soulhouse 620 N. Maple Dr., Beverly Hills,
 Cal.
 Sound Lab 3030 Post St., Jacksonville, Fla.
 Sound 6533 Hollywood, Hollywood 23, Cal.
 Soundercraft 21300 Pacific Coast Highway Mali-
 bu, Cal.
 Source 916 Kearney San Francisco, Cal.
 South Eastern European 35 W. 92nd N.Y.C.
 South Mountain 237 W. 54, N.Y.C.
 South Philadelphia 1549 Mc Kean Phila., Pa.
 Southeast 2712 Dickerson Rd., Nashville, Tenn.
 Southern Belle 3324 W. End Nashville, Tenn.
 Southland 2577 Oxford S., Memphis, Tenn.
 Southside 1650 Broadway, N.Y.C.
 Spangle 115-B Third Ave. N. Nashville, Tenn.
 Spanish 127 W. 48th N.Y.C.
 Spanka 119 W. 57th N.Y.C.
 Spare Rib 200 W. 57th N.Y.C.
 Spark 145 N. Canyon Monrovia, Cal.
 Sparkling 319 Seventh Ave. N. Nash., Tenn.
 Spartacus 150 W. 55th N.Y.C.
 Spartus 123½ E. Tennessee St. P.O. Box 740
 Florence, Ala.
 Spearhead 370 W. 35th N.Y.C.
 Specialty 1453 N. Vine Hollywood, Cal.
 Bill Spencer's 3759 Third Los Angeles, Cal.
 Spindel 305 E. 93rd N.Y.C.
 Spendo 3009 W. Vernon Los Angeles, Cal.
 Sphinx 6263 Saylin Los Angeles, Cal.
 Spindletop 157 W. 57th N.Y.C.
 Spinnet 1205½ S. La Cienega Los Angeles, Cal.
 Spinmill 15th & Locust Phila, Pa.
 Spinning Wheel 511 Fifth N.Y.C.
 Spiral 200 W. 57th N.Y.C.
 Spitzer 270 Madison N.Y.C.
 Ruth Spivak 806 Seventh N.Y.C.
 Spivey 443 Waverly Brooklyn, N.Y.
 Spook 815 Sixteenth S. Nashville, Tenn.
 Sportin Life 3606½ Bagley Los Angeles, Cal.
 Spring Valley 659 Tenth N.Y.C.

Sprite P.O. Box 38444 Hollywood Cal.
 Spur 10560 Wilshire Los Angeles, Cal.
 Square Deal 13027 Lorne, N. Hollywood, Cal.
 Square 1650 Broadway N.Y.C.
 Sta-ber 400 E. 33rd Chicago, Ill.
 Stacey 11016 Kittridge N. Hollywood, Cal.
 Stadium 1601 N. Gower Hollywood, Cal.
 Staff Box 32, Steamboat, Nev.
 Stafford 4812 Carmen Las Vegas, Nev.
 Stag 10 Marlo Belleville, Ill.
 Stahl 145 W. 57th N.Y.C.
 Stairway P.O. Box 1224 Mobile, Ala.
 Stamps-Baxter (see Affiliated)
 Stan 1697 Broadway N.Y.C.
 Stand-Out 717 Washington Gary, Ind.
 Stanford 2 W. 45th N.Y.C.
 Stanger P.O. Box 297 Maple Shade, N.J.
 Stanrick 1569 Sunset Los Angeles, Cal.
 Stanson 185 N. Wabash Chicago, Ill.
 Staple 649 E. 89th Chicago, Ill.
 Star Tunes 1607 El Centro, Hollywood
 Starday Box 115 Madison, Tenn.
 Stardom 942 W. 32 Pl. Chicago, Ill.
 Stardust 1650 Broadway N.Y.C.
 Starfire 511 Fifth N.Y.C.
 Starflite 271 W. 125th N.Y.C.
 Starflower 1225 Sixth N.Y.C.
 Starmaker 4469 Charleswood Memphis, Tenn.
 Starrite 314 E. 11th Houston, Texas
 Stars P.O. Box 9687 N. Atlanta, Ga.
 Star-Shun Flood Bldg San Francisco, Cal.
 Starstan 742 South Hill Los Angeles, Cal.
 Milt Staviv 756 Seventh N.Y.C.
 Stazybo 1650 Broadway N.Y.C.
 Steary 1270 6th N.Y.C.
 Stebrita (see Lois)
 Ted Steele 1440 Broadway N.Y.C.
 Stefani 226 E. 36th N.Y.C.
 Steinway 2 W. 45th N.Y.C.
 Stelen 8809 Oakwild Lane Hollywood, Cal.
 Steller 139 E. 33rd N.Y.C.
 Stermar 7250 Beverly Los Angeles, Cal.
 Sternick 318 W. 48th N.Y.C.
 Stept Bros. 203 N. Wabash Chicago, Ill.
 Stereo 456 N. Mansfield Los Angeles, Cal.
 Jos. W. Stern & Co. (E. B. Marks)
 Stern 215 Banks San Francisco, Cal.
 Shepard Stern 823 S. Wabash Ave. Chicago
 Arthur Steven 1018½ South Norton Los An-
 geles, Cal.
 Stevil 1650 Broadway N.Y.C.
 Stevo 308 Lenox Ave., N.Y.C.
 Stillman S 1715 Broadway N.Y.C.
 Stillran 134 N. 55th St, N.Y.C.
 Stinson 5966 Lakeview Detroit Mich.
 Stock 1619 Broadway N.Y.C.
 Stonestrow 17 Minetta St., N.Y.C.
 Stonewall 815 Sixteenth Nashville, Tenn.
 Stoneybrook 917 Sydney St. Philadelphia
 Storm Jordan 1700 Broadway, N.Y.C.
 Storm King 121 47th N.Y.C.
 Straight Ahead 1650 Broadway N.Y.C.
 Strato-Muse 1650 Broadway N.Y.C.
 Street 185 N. Wabash Chicago, Ill.
 String 929 West End N.Y.C.
 Stringer 1204 Dallas Nashville, Tenn.
 Strobi 890 Sixth N.Y.C.

Studio 157 W. 57th N.Y.C.
 Style and Song 291 Broadway N.Y.C.
 Style 20 E. Jackson Blvd., Chicago, Ill.
 Styletone 1650 Broadway, N.Y.C.
 Su Mu Pub. 1041 N. Formosa, Hollywood, Cal.
 Suarez 6605 Hollywood Blvd., Hollywood, Cal.
 Suburban 550 Fifth N.Y.C.
 Sudbury 6224 Teesdale N. Hollywood, Cal.
 Suero 1697 Broadway N.Y.C.
 Suffolk 10 Columbus Circle, N.Y.C.
 Sugar Ray 1475 Broadway, N.Y.C.
 Sulpat 1607 Broadway, N.Y.C.
 Sultan 255 West 55th St, N.Y.C.
 Sun Valley 632 N. Dearborn, Chicago, Ill.
 Sunbeam 22 W. 48th N.Y.C.
 Sun-Crest 1614 N. Argyle Hollywood, Cal.
 Sunday 1 N. La Salle Chicago, Ill.
 Sundown 3035 W. 38th Chicago, Ill.
 Sunno 150 W. 58th N.Y.C.
 Sunny 439 S. Wabash, Chicago, Ill.
 Sunnyside 1619 Broadway, N.Y.C.
 Sunnyside 1650 Broadway N.Y.C.
 Sunrise 1619 Broadway N.Y.C.
 Sunshine 408 N. Rodeo Beverly Hills, Cal.
 Sun-Vine 1507 N. Vine Hollywood, Cal.
 Sure 1619 Broadway N.Y.C.
 Sure-Fire 801 16th Ave. S., Nashville, Tenn.
 Surf Music 21 W. Illinois Chicago, Ill.
 Surimi 1479 Vine Hollywood, Cal.
 Susan 79 W. Monroe Chicago, Ill.
 Suto 1135 S. Beverly Dr. Los Angeles, Cal.
 Sutter 756 7 Ave, N.Y.C.
 Suwal 150 W. 55th N.Y.C.
 Sweo 250 W. 57th N.Y.C.
 Sweet & Swing 9655 S. Prairie Ave, Chicago
 Sweetheart 1650 Broadway N.Y.C.
 Sweetheart 1650 Broadway N.Y.C.
 Swing & Tempo 1560 Broadway N.Y.C.
 Swingin 150 W. 55th N.Y.C.
 Sycamore P.O. Box 1654 Hollywood, Cal.
 Sylvia 1650 Broadway N.Y.C.
 Symbol 1055 N. El Centro, Los Angeles, Cal.
 Symbolic 320 W. 76th N.Y.C.
 Syndicate 6869½ Fountain, Hollywood, Cal.
 T-C 1614 N. Cherokee Hollywood, Cal.
 T. M. 101 W. 55th N.Y.C.
 T. N. T. 1422 W. Poplar an Antonio, Texas
 TPA 555 Madison N.Y.C.
 Tacit 1644 Veteran Los Angeles, Cal.
 Taffy 1570 N. Gower Hollywood, Cal.
 Taggie 119 W. 57th N.Y.C.
 Tailormade 1783 S. La Cienega, Los Angeles,
 Cal.
 Tajah 200 W. 57th N.Y.C.
 Tal 1919 S. Tenth Phila, Pa.
 Talcoa Hollywood Knickerbocker Hotel, Holly-
 wood, Cal.
 Tallard 8303 Melrose Ave. Los Angeles
 Tamara 343 W. 58th N.Y.C.
 Tamkoda 5004 Meirose Hollywood, Cal.
 Tampico 1170 Broadway, N.Y.C.
 Tangerine 100 W. 42nd N.Y.C.
 Tangier 1674 Broadway N.Y.C.
 Tani-Lori P.O. Box 2331 Hollywood, Cal.

Tannen 850 Seventh N.Y.C.
 Tanridge 850 Seventh N.Y.C.
 Irving Tanz 836 Eastern Pkwy., Bklyn., N.Y.
 Taps 1619 Broadway N.Y.C.
 Tara Claire 154 Bristol Ave. N., L.A., Calif.
 Ta-Rah 3322 W. Peterson Chicago, Ill.
 Tarheel P.O. Box 115 Madison, Tenn.
 Tarry-Town 1619 Broadway N.Y.C.
 Tartan 673 Palm Dr., Glendale, Cal.
 Task 2300 N.W. 56 Terrace, W. H'wood, Fla.
 Tatlin 2959 4th Los Angeles, Cal.
 Taurus 301 E. 47th N.Y.C.
 Tecumsseh P.O. Box 9687, N. Atlanta, Ga.
 Teen Ager 6407 S. Kedzie Chicago, Ill.
 Tejas 5513½ E. Grand, Dallas, Texas
 Telecast 69 W. Washington Chicago, Ill.
 Tele-Graff 3 Sheridan Sq. N.Y.C.
 Tele-Reco 3455 Cahuenga, Los Angeles, Cal.
 Tejas 5513½ E. Grand, Dallas, Texas
 Temopic Ent. S.A., 780 Gower, H'wood Cal.
 Temple 5 S. 60th Phila, Pa.
 Tempus 423 1st Natl. Bank Bldg., Peoria, Ill.
 Tenneva 300 W. 33rd, N. Little Rock, Ark.
 Tenn-Tex 319 Seventh Av. N., Nashville, Tenn.
 Tenor 248 Sherer Blvd., Franklin Sq., N.Y.C.
 Tentap 627 Madison N.Y.C.
 Tepajo 19 Arlington St, Boston
 Teresa 1479 N. Vine Hollywood, Cal.
 Terese 200 E. Superior Chicago, Ill.
 Tereve-Laen 35 E. Wacker Chicago, Ill.
 Terry 1001 Garden Hwy., N. Sacramento, Cal.
 Terra-Orb 6064 Hollywood Blvd., H'wood, Cal.
 Lou Terrasi 254 W. 47th N.Y.C.
 Terry-Wilkins 152 W. 49th N.Y.C.
 Tetlon 1243 N. Virgil Los Angeles, Cal.
 Tex 9028 Sunset Blvd., Los Angeles, Cal.
 Textical 962 N. Ardmore Hollywood, Cal.
 Thalia 804 E. Imperial Highway, L.A., Cal.
 Tharpe 1619 Broadway N.Y.C.
 Thayer 2031 Thayer Los Angeles, Cal.
 Theatre 1619 Broadway N.Y.C.
 Thelma's 8040 Dexter, Detroit, Mich.
 Thimble 200 W. 57th N.Y.C.
 Ray J. Thomas 846 N. Cahuenga, H'wood, Cal.
 Thomas-Cole 117 W. 48th N.Y.C.
 Thompson 2836 W. Harrison Chicago, Ill.
 Thornwood 11 Charlton N.Y.C.
 Three Boys 1270 Ave. of Americas, N.Y.C.
 Three Speed 8 E. 48th N.Y.C.
 Three Star 143 W. 51st N.Y.C.
 Thrush 2991 Ingledeale, L.A., Cal.
 Thunder 3013 Wingate, Nashville, Tenn.
 Thunderbird 140 E. 56th N.Y.C.
 Thursday 1619 Broadway N.Y.C.
 Tiara 1650 Broadway N.Y.C.
 Tibor 200 W. 57th N.Y.C.
 Tickson 8462 Sunset Blvd. Los Angeles
 Richard Ticktin 501 Tenth N.Y.C.
 Tidal 2675 Federal, W. Los Angeles, Cal.
 Tideland 756 Seventh N.Y.C.
 Tiffany 3048 School, Oakland, Cal.
 Tiger 1841 Broadway N.Y.C.

(Continued on next page)

ELLA SINGS

"She's Just A Quiet Girl (Mae)"

The new Riz Ortolani song
 from the MGM Motion Picture
 and Anatole DeGrunwald
 Production

THE Yellow Rolls-Royce

b/w "We Three" VK-10359



Verve Records is a division of
 Metro-Goldwyn-Mayer, Inc.

BMI PUBLISHERS

Tiki Music 616 Exchange Bldg., Nashville, Tenn.
Timbrea 1680 N. Vine Hollywood, Cal.
Time 1790 Broadway N.Y.C.
Timpkin 1405 E. Sixth Cleveland, O.
Tin Pan Valley, 1508 Dickerson, Nashville, Tenn.
Tinadele 13221 S. Avalon, Los Angeles, Cal.
Tiparm 200 W. 57th N.Y.C.
Tippy 408 W. 57th N.Y.C.
Tirod 729 Seventh N.Y.C.
Titan 3020 Hollyridge Hollywood, Cal.
Titanic 706½ W. Florence, Los Angeles, Cal.
Tito 826 7 Ave., N.Y.C.
Tivador 1064 E. 12th Jacksonville, Fla.
T.M., 1619 Broadway, N.Y.C.
Tobby 3121 Castle Heights, Los Angeles, Cal.
Tobi-Ann 1650 Broadway N.Y.C.
To-da 202 Hirst, E. Lansdowne, Pa.
Todd 1719 W. End Nashville, Tenn.
Tog 6920 Taylor Rd., Cincinnati, O.
Tojam 335 E. 10th N.Y.C.
Toland 5 So. 60th Phila. Pa.
Toles 60 E. 42nd N.Y.C.

Toluca 10058 Valley Spring Lane, N. Hollywood, Cal.
Tomac 200 W 108, N.Y.C.
Tom Cat P.O. Box 121 Abbeville, Ala.
Tomahawk 98 Scobey Nashville, Tenn.
Tomboy Petroleum Center San Antonio, Texas
Tomkins 1075-5 Lynch, Jackson, Miss.
Tomm 2360 S. Beverly Glen Los Angeles, Cal.
Tommy 15 W. 84th N.Y.C.
Tomorrow's 353 E. 50th N.Y.C.
Tom-Tom Post Office Box 4734 Compton, Cal.
Tone 511 Fifth N.Y.C.
Tone-Craft 2709 Germantown Phila, Pa.
Tonecraft 12412 Ventura Blvd, Studio City, Calif.
Tonto 11735 Hatteras, N. Hollywood, Calif.
Toole 500 E. 33 1906 Chicago, Ill.
Top Flight 3828 Grove Oakland, Cal.
Top Talent 617 Exchange Building, Nashville
Top Ten 231 Lincoln New Rochelle, N.Y.
Topaz 9171 Wilshire Beverly Hills, Cal.
Topper 6619 Northumberland, Pittsburgh, Pa.
Tornado 525 W. Vernon Los Angeles, Cal.
Torpedo 356 40th N.Y.C.

Torrington 88 Water Torrington, Conn.
Torso 134 W. 58th N.Y.C.
Toussaint 616 W. 116th N.Y.C.
Herbert G. Tovey 1619 Broadway, N.Y.C.
Tower Hill 305 W. 45th N.Y.C.
Tower 3621 Floral Nashville, Tenn.
Tower of Gold 2226 N. Alvarado Los Angeles, Cal.
Towles 367 E. Paces Ferry Rd., N.E., Atlanta, Ga.
Town and Country 756 Seventh N.Y.C.
Townsend-Shayne 1619 Broadway N.Y.C.
Tracey 1451 Madison Memphis, Tenn.
Trade Mark 4707 Broadway Chicago, Ill.
Traff 916 Kearny San Francisco, Cal.
Tragan 6332 Brynhurst Los Angeles, Cal.
Trail 3921 McComas Fort Worth, Texas
Trailers End 146 7th Ave N., Nashville, Tenn.
Tramer P.O. Box 5314 San Diego, Cal.
Tranco 742nd Acwron, Zapata Afsta, Zapata, Texas
Trans-America 474 Daniels Beverly Hills, Cal.
Trans-Music 1619 Broadway N.Y.C.
Trans-Pacific 1619 Broadway N.Y.C.

Trans-World 1719 W. End Nashville, Tenn.
Transglobal 56 West 45th St, N.Y.C.
Trauma 6122 Delongpre Hollywood, Cal.
Travis 6425 Hollywood, Hollywood, Cal.
Traymore 1650 Broadway N.Y.C.
Tredlew 200 W. 57th N.Y.C.
Tree 905 16th Ave. N., Nashville, Tenn.
Trianon 3942 Third Detroit, Mich.
Tribute 250 W. 57th N.Y.C.
Tri-City 225 W. 57th N.Y.C.
Trickle 14812 Saticoy Van Nuys, Cal.
Tri-Dec State Bank-Haines City, Fla.
Tridon 237 West 54th St, N.Y.C.
Trigo 244 E. 13 N.Y.C.
Trim 81 Spring Valley Paramus, N.J.
Trinity (see T.M.)
Trio 1619 Broadway N.Y.C.
Tri-Park 101 W. 55th N.Y.C.
Triphi 588 Farnsworth Detroit, Mich.
Triple EEE 1619 Broadway N.Y.C.
Triplet 404 N. Roxbury, Beverly Hills, Cal.
Triple-Tone 1650 Broadway N.Y.C.
Tri-Staff 508 University Fairfax, Va.
Tri-Staff 1730 Eureka Way Redding, Cal.
Triumph 111 W. 57th N.Y.C.
Triumvirate 812 17 Ave. S., Nashville, Tenn.
Triway 224 N. Canon Beverly Hills, Cal.
Trojan 1356 W. San Madele, Fresno, Cal.
Tronic Box 115 Madison, Tenn.
Trophy 554 Fifth Ave. N.Y.C.
Tropical 2400 N.W. 27 St. Miami, Fla.
Trubill 13019 Cordary Hawthorne, Cal.
Truman 65 W. 129th N.Y.C.
Try Me 200 W 57, N.Y.C.
Tryton 1650 Broadway N.Y.C.
Tsoaris 224 W. 49th N.Y.C.
Ernest Tubb 1619 Broadway N.Y.C.
Tuckahoe P.O. Box 128 Madison, Tenn.
Tudor 1631 Broadway N.Y.C.
Tula 9033 Wilshire Beverly Hills, Cal.
Tulip Time 100 Seventh Pittsburgh, Pa.
Tulsa 747 E. Walnut Pasadena, Cal.
Tune-Art 156 W. 44th N.Y.C.
Tunecrafters 1607 El Centro, Hollywood
Tunetone 1650 Broadway N.Y.C.
Tuneville 3910 Baxter Nashville, Tenn.
Tu-Po 1604 E. 33rd Los Angeles, Cal.
Tupper 20 E. Tupper Buffalo, N.Y.
Turban 255 W. 55th N.Y.C.
Turntable 1697 Broadway N.Y.C.
Turvy 723 7th N.Y.C.
Tweety 420 E. 64th N.Y.C.
Twilight 223 W. 52nd N.Y.C.
Twin 1697 Broadway N.Y.C.
Twin Peaks 2166 Market San Francisco, Cal.
Twin-Star 2862 Horseshoe Drive S.E., Atlanta, Ga.
Twist P.O. Box 2921 Hollywood, Cal.
Two Jays 131 Garden Teaneck, N.J.
Two Minute 2025 N. Allen Altadena, Cal.
Two-Beat 445 Park N.Y.C.
Tybee 100 W. 42nd N.Y.C.
Tycora 134 W. 91, Los Angeles, Cal.
Typort 3 W. 57th N.Y.C.
Tyrol 1631 Broadway N.Y.C.
Ty-Tex P.O. Box 3321 Tyler, Texas

RECORD CARRYING CASE MFRS.

Aragon Products, Inc.
639 Island View Dr.
Santa Barbara, Calif.

Beckstrand Hoffman Machine & Tool
4126 E. Anaheim
Long Beach, Calif.

Coast Export Co.
2846 W. Pico Blvd.
Los Angeles, Calif.

Eckstein Recording Products Co.
8637 W. Washington Blvd.
Culver City, Calif.

Finebilt Mfg. Co.
2846 W. Pico
Los Angeles, Calif.

Garden City Mfg.
Garden City, L. I.

Garden States Hydraulics Corp.
189 Mall Dr.
North Plainfield, N. J.

Holland Electroplating Equipment
475 Keap St.
Brooklyn, N. Y.

Indus Manufacturing Co.
Indianapolis, Ind.

Johnson Machine & Tool
1702 W. 134th St.
Gardena, Calif.

King Records and Royal Plastics
1540 Brewster Ave.
Cincinnati, Ohio

M G M Records
Bloomfield, N. J.

RCA Victor
Hollywood, Calif.

RCA Victor
501 N. LaSalle St.
Indianapolis, Ind.

RCA Victor
Route 46, Franklin Ave.
Rockaway, N. Y.

RCA Victor
155 E. 24th St.
New York 10, N. Y.

Standard Paper Box Machine
476 Broome St.
New York 13, N. Y.

Standard Tool & Die
Kearny, N. J.

Alan Insulated Mfg.
1107 McCarter Highway
Newark 4, N. J.

Amberg File & Index
1637 Duane Blvd.
Kankakee, Ill.

Astatlc
252 Harbor St.
Conneaut, Ohio

Beard Mfg. Co., Inc.
4553 W. Harlison
Chicago, Ill.

Capitol Records
(see local distributors)

Samuel Caplan
Philadelphia, Pa.

Carol Industries
335 Carroll St.
Brooklyn 31, N. Y.

Casecraft (Div. of Red Rope Stationery)
70 Washington Ave., Brooklyn, N. Y.

Dick Clark Cases
Raye Productions
2522 N. Broad St.
Philadelphia 32, Pa.

Cole Publishing Co.
823 So. Wabash Ave.
Chicago, Ill.

Columbia Records
(see local distributor)

Columbus Plastic Prod. Inc.
1625 W. Mound St.
Columbus, Ohio

Deccafle
Decca Records, Inc.
445 Park Ave.
New York, N. Y.

Disc Mate Cases
Red Rope Industries
70 Washington St.
Brooklyn 1, N. Y.

Embro Mfg. Co.
P.O. Box 407
908 Lawrence Rd., N.E.
Canton, Ohio

Enterprise
Toronto, Ont., Canada

Fine-Tone
7111 20th Ave.
Brooklyn 4, N. Y.

Freedman Aircraft Record
Display Fixtures
Charlevoix, Mich.

Hillcraft, Inc.
11 West 30th St., N.Y.C.

Knight Industries
164 Liberty Ave., Brooklyn, N. Y.

Le-Bo Products Co.
418 West 49th St., N.Y.C.

Machlon
780 E. 134 St., N.Y.C.

Melody Record Supply Co.
693—10th Ave., N.Y.C.

Metalcraft Prod. Co., Inc.
Mascher & Lippincott Sts.
Philadelphia 33, Pa.

Monroe Novelty
383 Bridge
Grand Rapids, Mich.

Nachman Products
780 E. 134th St.
Bronx, N. Y.

Olsen Wire Products
Baltimore, Md.

Olympia
721—11th Ave., N.Y.C.

Pic-A-Disc
Art & Industry, Inc.
11 West 30th St., N.Y.

Platter Porter
Columbus, Ohio

Qualitone Ind., Inc.
102 Columbus Ave.
Tuckahoe, N. Y.

Record Accessories Corp.
693 — 10th Ave.
New York 36, N. Y.

Renard Royce
825 So. Wabash Ave.
Chicago 5, Illinois

Replogle Globes, Inc.
1901 N. Narragansett Ave.
Chicago 39, Ill.

Seebro Products Co.
2019 S. Michigan Ave.
Chicago 16, Ill.

Seebro Warner Bros.
4000 Warner Blvd.
Burbank, Calif.

H. Roger Smith
10 Walnut St.
Phila. 7, Pa.

Specialty Case Mfg. Co.
1701 N. 8th St.
Philadelphia, Pa.

Standard Products
741 West Front St.
Plainfield, N. J.

Sturbridge Industries, Inc.
258 Irving St.
Framingham, Mass.

Wakefield Industries
Lowell, Mass.

Walce-Clevite
60 Franklin St.
E. Orange, N. J.

Warner Bros.
666 Fifth Ave., N.Y.C.

Una 206½ Union Nashville, Tenn.
Unamic P.O. Box 8705 Nashville, Tenn.
Unart 729 7th N.Y.C.
Unbelievable 1650 Broadway N.Y.C.
Underwood 7155 Hawthorne, Hollywood, Cal.
Universal 4403 Sheridan Rd., Chicago, Ill.
Up 639 Madison Memphis, Tenn.
Up Town 1737 W. Monroe Chicago, Ill.
Upa 440 Lakeside Burbank, Cal.
Upam 119 W. 57th N.Y.C.
Up Tight 2109 Lake Ave., Baltimore, Md.
Uptrend 3020 Hollyridge Hollywood, Cal.
Uranus 7th Ave. & 50th St., N.Y.C.
Max Urban 1651 Cosmo Hollywood, Cal.
Urso 882 E. 57th Los Angeles, Cal.

V.I.P. P.O. Box 38444 Hollywood, Cal.
Vadim 13141 Oxnard St. Van Nuys, Calif.
Val-Art 1614 N. Cherokee, Hollywood, Cal.
Valbar 1650 Broadway N.Y.C.
Val-Dare 5743 Cahuenga, N. Hollywood, Cal.
Valjean 5136 W. 41 Denver 12, Col.
Valjo (see Lois)
Valley 1619 Broadway N.Y.C.
Valley 1740 Broadway N.Y.C.
Valley 6087 Sunset Hollywood, Cal.
Valleydale 1619 Broadway N.Y.C.
Valtone 910 N. Foothill Rd. Beverly Hills, Cal.
Vamp 963 First National Bldg., Detroit, Mich.
Van Brunt 6330 Sunset Blvd., Hollywood, Cal.
Van Doe 5909 Melrose Hollywood, Cal.
Van Houton 6500 Charlesworth, N. Hollywood
Van Lee 1343 E. Harvard St. Glendale, Cal.
Van Winkle & Darian 1549 N. Vine Hollywood, Cal.
Vanadore 1537 McGavock Pike Nashville Tenn.
Vanguard 6087 Sunset Hollywood, Cal.
Vanjo Box 516 Goodlettsville, Tenn.
Van-Nauert 1620 Margate Rd., Palos Verdes, Cal.
Vapac 2642 S. Michigan Chicago, Ill.
Variety 145 Linn Yonkers, N.Y.
Varnes 3547 N. 21st Phila., Pa.
Varsity 2643 South Third Phila., Pa.
Vaughn 1692 Madison Memphis, Tenn.
Stuart Vavrin 2119 W. 54th Chicago, Ill.
Benjamin Veal 4209 Western Los Angeles Cal.
Veda 1724th N.Y.C.
Vedco 2721 A. E. 6th Long Beach, Cal.
Vedel 209 Fourth, W. Hendersonville, N.C.
Vegas 3788 Paradise Rd., Las Vegas, Nev.
Vejac 8462 Sunset, Hollywood, Cal.
Emil Velazco 723 Seventh N.Y.C.
Velloro P.O. Box 38530, Hollywood, Calif.
Venetia 1501 W. Cortland Chicago, Ill.
Venice 8300 Santa Monica Hollywood, Cal.
Verbo 2751 McConnell Los Angeles, Cal.
Vernal 240 Central Park So., N.Y.C.
Vertigo 727 N. Kedzie Chicago, Ill.
Vibra 1036 Hilldale Los Angeles, Cal.
Vicki 850 7th Ave., N.Y.C.
Videorama 156 W. 44th N.Y.C.
Vidor 1001 N. Lincoln Burbank, Cal.
Vier P.O. Box 723 Hollywood, Cal.
View 1570 N. Edgemond Los Angeles, Cal.
Vijay 2215 Edison Detroit, Mich.
Villa 1619 Broadway N.Y.C.
Village 37-11 87th Jackson Heights, N.Y.
Villanova 1619 Broadway N.Y.C.

(Continued On Next Page)

BMI PUBLISHERS

Vincent 1323 S. Michigan Chicago, Ill.
 Peter Vincent 250 N. Canon Beverly Hills.
 Viola 522 Patterson Nashville, Tenn.
 Violet 4411 S. Mettler Los Angeles, Cal.
 Vir-Cel 5938 Kimble Ave., Phila., Pa.
 Virgo 2586 N. Beachwood Hollywood, Cal.
 Viscount 1619 Broadway N.Y.C.
 Vision 119 W. 57th N.Y.C.
 Vista 1674 Broadway N.Y.C.
 Vivo Music 185 N. Wabash Chicago, Ill.
 Voca 1650 Broadway N.Y.C.
 Vogue 1619 Broadway N.Y.C.
 Vokes New Kensington, Pa.
 Vol 920 Sutton Hill Rd., Nashville, Tenn.
 Volo 1650 Broadway N.Y.C.
 Voltage 8230 Hollywood, Hollywood, Cal.
 Volunteer 56 Ferry Newark, N.J.
 Vondart 887 Chatwood Memphis, Tenn.
 Vonglo 1674 Broadway, N.Y.C.
 Vulcan 96 Perry N.Y.C.

W. W. 11360 Dona Dorotea, Studio City, Cal.
 Wabbit 5880 Hollywood, Hollywood, Cal.
 Wade 20 Beekman N.Y.C.
 Wajoma 157 W. 57th N.Y.C.
 Wakabe 271 Madison N.Y.C.
 Walaine 8912 Firestone Plaza Los Angeles.
 Walhridge 154 W. 57th N.Y.C.
 Harold Wald 146 W. 54th N.Y.C.
 Ed Waller 13603 S. Avalon Los Angeles, Cal.
 Wallis 4450 N. Jefferson Miami Beach, Fla.
 Walnut 148 W. 126th N.Y.C.
 Wal-rich 3351 W. 43rd Pl. Los Angeles, Cal.
 Wanda 429 W. Hortter, Phila., Pa.
 Wanellen 850 7 Ave. N.Y.C.
 Wanessa 154 W. 54th N.Y.C.
 Ward & Sears 1790 Broadway N.Y.C.
 Billy Ward 6000 Sunset Hollywood, Cal.
 Clara Ward 3800 N. 13th Phila., Pa.
 Jay Ward 8218 Sunset Los Angeles, Cal.
 Warden Box 8061 Nashville, Tenn.
 Ward-Marks 1258 N. La Brea Hollywood, Cal.
 Ware's 6112 Selma Hollywood, Cal.
 Warren 349 E. 49th N.Y.C.
 Warwood, 2712 Dickerson Road, Nashville
 Waterfall 1208 Lee Ave., Morristown, Tenn.
 We Three 1650 Broadway N.Y.C.
 Waymore 1619 Broadway N.Y.C.
 Roger Wayne 1650 Broadway N.Y.C.
 Weddington 14707 McCormick Van Nuys, Cal.
 Wedlaw 5606 Beer Ave, Los Angeles
 Weger 1650 Broadway N.Y.C.
 Weiss & Barry 1556 N. La Brea Hollywood.
 Welcome Music 31 W. 54th N.Y.C.
 Welden and Weiss 8833 Sunset Blvd., L.A.
 Welland 6311 Yucca St, Hollywood
 Wellesley 1050 Fifth Ave, N.Y.C.
 Maurice O. Wells 3816 N. Clark Chicago, Ill.
 Welton Music 2847 Effie Los Angeles, Cal.
 Wemar 1619 Broadway N.Y.C.
 Wendell 9229 Sunset Blvd, Los Angeles
 Wensley 3 Wensley Ave, Great Neck, N.Y.
 Werber 608 Fifth Ave. N.Y.C.
 Bobe Wes 4542 Live Oak Mesquite, Tex.
 Weslu 1650 B'way, N.Y.C.
 West Coast 340 N. Camden Beverly Hills, Cal.
 Ted West 2809 W. Linden Nashville, Tenn.
 Westbury 2 W. 45th N.Y.C.
 Westfield 10859 Landale, N. Hollywood, Cal.
 Westgate 9350 Wilshire Blvd. Beverly Hills.
 West-Higgins 2930 Boston Detroit, Mich.
 Westlake 7190 Sunset Los Angeles, Cal.
 Westside 729 Seventh N.Y.C.
 Westwall Box 115 Madison, Tenn.
 Westwind 8510 Sunset Hollywood, Cal.
 Wheel of Fortune 6100 Afton Hollywood, Cal.
 Whimsy Box 1415 Hollywood, Cal.
 White Castle 1650 Broadway N.Y.C.
 Elmore White 1650 Broadway N.Y.C.
 Mack White 1026 Market San Francisco, Cal.
 Whiteman 1520 N. Hayworth, Hollywood, Cal.
 Wian 511 Fifth N.Y.C.

Wil 14318 Wilfred Detroit, Mich.
 Wilberton 203 W. 126th N.Y.C.
 Wilbur's 55 W. 19th N.Y.C.
 Wildcat 1619 Broadway N.Y.C.
 Wilderness 913-17th Ave, So. Nashville
 Wildon 2 Park N.Y.C.
 Wildrick & Miller 630 Fifth N.Y.C.
 Wildwood 30 W. 60th N.Y.C.
 Wiley 1650 Broadway N.Y.C.
 Wilkay 1650 Broadway N.Y.C.
 Slim Willet 9109 Sunset Hollywood, Cal.
 Dootsie Williams 9512 S. Central Los Angeles.
 Kae Williams 3214 W. York, Phila., Pa.
 Williams 46 E. Walton Chicago, Ill.
 Ralph Williams 203 N. Wahash Chicago, Ill.
 Richard M. Williams 4532 Cimarron L.A.
 Willin 553 W. 51st N.Y.C.
 Willis-Woodward (E. B. Marks)
 Willstar 521 East Fifth St., # 18, N.Y.C.
 Wilshire 10558 Lauriston W. Los Angeles, Cal.
 Winco P.O. Box 972 Hollywood, Cal.
 Window 720 17th Ave. S., Nashville, Tenn.
 Wing Ding 1650 Broadway N.Y.C.
 Winlyn 200 W. 57th N.Y.C.
 Winneton 1619 Broadway N.Y.C.
 Winona Box 7256, Nashville
 Winsor 1220 N. Gardner Hollywood, Cal.
 Winter 1650 Broadway N.Y.C.
 Wise-O-Man P.O. Box 7006 Nashville, Tenn.
 Wistadala 1546 29th Phila., Pa.
 Wisto (see Lois)
 Milton G. Wolf 25 E. Jackson Chicago, Ill.
 Wolverine Box 5054 Detroit, Mich.
 Wonderland 500 S. Buena Vista Burbank, Cal.
 Woodbury 6087 Sunset Hollywood, Cal.
 Woodman 2077 S. Harvard Los Angeles, Cal.
 Woodstock 1697 Broadway N.Y.C.
 Woolf 13304 S. Norfolk Detroit, Mich.
 Woolcott 8448 Ridpath Los Angeles, Cal.
 Worart 550 Grant St., Pittsburgh, Pa.
 Wow 505 E. 87th N.Y.C.
 Wrath 270 N. Canon Beverly Hills, Cal.
 Wren 715 E. 111th Pl. Los Angeles, Cal.
 Mac Wright 200 W. 57th N.Y.C.
 Peter Wright 143 W. 54th Los Angeles, Cal.
 Wright-Gerstl 7118 Coldwater Canyon, N. Hol-lywood, Cal.
 Wrist 8215 Romaine Los Angeles, Cal.
 Wyndham 200 W. 57th N.Y.C.
 Wynmar 114 W. 70th N.Y.C.
 Wynne 1619 Broadway N.Y.C.

The X Plus Y 271 W. 125th N.Y.C.
 X-L 607 S. Commonwealth Los Angeles, Cal.
 Xenophon 4264 S. Central Los Angeles, Cal.

Yanden 3494 Obion Dr., Memphis
 Yellow Sand 3852 N Euclid Tucson, Ariz.
 Yenom 1781 Hauser Blvd, Los Angeles, Calif.
 Yonah P.O. Box 425 Louisville, Ga.
 Young Peoples 100 Sixth N.Y.C.
 Yucca 8134 S. Alameda Los Angeles, Cal.
 Yuki 4182 Farmdale, N. Hollywood, Cal.
 Yvonne 9328 S. Parnell Chicago, Ill.

Z-12 5211 Santa Monica Hollywood, Cal.
 Zarak 501 E. 32 St., Chicago, Ill.
 Zarpac 11680 Pendleton Sun Valley, Cal.
 Zarr 1674 Broadway N.Y.C.
 Zayo P.O. Box 1173 Hollywood, Cal.
 Zeld 335 W. 78th N.Y.C.
 Bob Zieff 2477 Cheremoy Hollywood, Cal.
 Zim Music 236 W. 55th N.Y.C.
 Zira 271 W. 125th N.Y.C.
 Zodiac 1733 Broadway N.Y.C.
 Zondervan Music 1619 Broadway N.Y.C.
 Zordun Music Co. 52 St. Nicholas, N.Y.C.

PHONOGRAPH NEEDLE MFRS.

Admiral
 3800 W. Cortland
 Chicago, Ill.

American Laubscher
 250 West Fifty-Seventh St.
 New York, N. Y.

American Stylus
 Pageant Needles
 436 Wyoming Ave.
 Scranton, Pa.

Astatic
 Harbor & Jackson Sts.
 Conneaut, Ohio

Capps
 20 Addison Place
 Valley Stream, N. Y.

Columbia Accessories
 799 7th Ave.
 New York, N. Y.

Cleartone Reproductions Corp.
 18-06 127 St.
 College Pt., N. Y.

Duotone
 Locust St.
 Keyport, New Jersey
 Electro-Voice
 Buchanan, Michigan

Fidelltone
 6415 Ravenswood Ave.
 Chicago, Illinois

Fine-Tone
 7111 20th Ave.
 Brooklyn, N. Y.

Heart Products
 Box 6267
 Philadelphia, Penn.

Jensen Industries
 7333 W. Harrison St.
 Forest Park, Ill.

M. A. Miller
 Fourth & Church Sts.
 Libertyville, Ill.

Olympia Mfg.
 614 51st St.
 New York, N. Y.

PRINTERS AND LITHOGRAPHERS

•Independent Record Mfrs. Assn.
 ••Western Record Pressers Assn.

Alemo Ltd.
 737 Drake St.
 New York, N.Y.

Audio Paks
 Swarthmore Industrial Center
 Box 486
 Swarthmore, Pa.

Bertco Press
 4862 Santa Monica Blvd.
 Los Angeles, Calif.

Colorcraft
 200 Henry St.
 Stamford, Conn.

••Container Kraft
 Carton & Paper Supp. Co.
 801 E. 61st St.
 Los Angeles, Calif.

Design and Printing
 207 W. 25th St.
 New York, N.Y.

Globe Productions
 1255 Oak Pt. Ave.
 New York, N.Y.

Gopher Litho of Calif.
 Box 812
 Berkeley, Calif.

Gregg Moore Lithographing
 111 N. Whacker Dr.
 Chicago 6, Ill.

Harrison Art Advg.
 2032 W. 16th St.
 Philadelphia, Pa.

Ivy Hill
 1 Ivy Hill Lane
 Brooklyn 11, N.Y.

Kaumagraph
 1214 Walnut St.
 Philadelphia, Pa.

Community Press
 6047 Woodland Ave.
 Phila., Pa.

King Records
 1540 Brewster Ave.
 Cincinnati, Ohio

Lee-Myles Assoc.
 40 W. 57th St.
 New York, N.Y.

Lithographer Corp. of America
 1501 State St.
 Bridgeport, Conn.

Mac Murray Press, Inc.
 22 Jones St.
 New York, N.Y.

Mehl Manufacturing Co.
 2057 Reading Rd.
 Cincinnati, Ohio

Micitone Printing Corp.
 11 Ave. D
 New York, N.Y.

•J. Monheimer & Co., Inc.
 108 Fulton St.
 New York 38, N.Y.

One Stop Service, Inc.
 100 W. 42 St.
 New York, N.Y.

Photo Press
 Congress Expressway
 Gardner Rd.
 Broadview, Ill.

Queen City Album Co.
 2774 Blue Rock Rd.
 Cincinnati, Ohio

Queens Litho
 Kaltman Press
 52-25 Barnett Ave.
 Long Island, N.Y.

••Records Labels
 6201 Santa Monica Blvd.
 Hollywood, Calif.

Rite Records Products
 3930 Spring Grove Ave.
 Cincinnati, Ohio

Shorewood Press
 305 E. 45th St.
 New York, N.Y.

Sterling Title Strip
 1175 Broad St.
 Newark, N.J.

Supreme Printing Service
 130 W. W. 46th St.
 New York, N.Y.

PHONOGRAPH NEEDLE MFRS.

Pfanstiehl
 104 Lake View Ave.
 Waukegan, Illinois

Philco Accessory Div.
 Tioga & "C" Sts.
 Philadelphia, Pa.

Qualitone Industrles, Inc.
 102 Columbus Ave.
 Tuckahoe, N. Y.

Recoton
 46-23 Crane St.
 Long Island City, N. Y.

Televox
 46 Lakeview Ave.
 Yonkers, N. Y.

Transcriber Co., Inc.
 Dept. C-Box 478
 Attleboro, Mass.

Tetrad Co.
 62 St. Mary St.
 Yonkers, N. Y.

Walco
 60 Franklin St.
 East Orange, N. J.



RECORD SALES COMPANY

2437 E. 57TH ST., LOS ANGELES, CALIF. 90058. PHONE: 582-0841. CABLE: ALLRECORD

**CUSTOM PRESSING • PLATING • MASTERING
 LABEL PRINTING • SHIPPING • WAREHOUSING
 ALL SIZES AND SPEEDS**

SERVICED MAJOR AND PRIVATE LABELS FOR OVER 30 YEARS

**FAST—DEPENDABLE SERVICE
 RELIABLE**

SESAC PUBLISHERS

Abernathy, Briarcliff Hotel, 1050 Ponce de Leon Ave., N.E., Atlanta, Ga. 30383
Accordion, 133 Seventh Ave., So., New York, N. Y. 10014
Albright, 77 West Washington St., Chicago 2, Ill.
Amanda, Inc., 235 46th St., New York, N. Y. 10036
A.M.S. 7044 S. Cornell, Chicago 5, Ill.
Amso, 240 West 55th St., New York, N. Y. 10019
Andrea, 925 N. Third St., Philadelphia, Pa. 19123
Augsburg, 426 South Fifth St., Minneapolis 15, Minn.
Avalon, 10 Laurel Place, Yonkers, N. Y. 10704
Aztec, 61 Church Street, Malverne, L.I., N.Y.

Babwin, P. O. Box 145, Beaumont, Calif. 92223
Barnhouse, C. L., 110 B Ave., East, Oskaloosa, Iowa 52577
Bartlett, E. M., Powell, Mo. 65730
Bass, Company, The, 351 West 52nd Street, New York, N. Y. 10019
Bates & Bates, Box 1281, Nashville, Tenn.
Bava's, John Music, Davis, West Virginia
Beirly, Alfred Company, 1834 Ridge Ave., Evanston, Ill.
Bendix, 77 West Washington St., Chicago 2, Ill.
Better Choirs, Inc., 4145 Kalamazoo, S.E., Grand Rapids, Mich. 49508
Bilruth, 11 Riverside Drive, New York, N. Y. 10023
Blackwood, Cecil, 209 North Lauderdale, Memphis, Tenn.
Blackwood, James, 209 North Lauderdale, Memphis, Tenn.
Blue Coast, 1401 Avenue Y, Brooklyn, New York
Braun, Hubert J., 240 West 55th Street, New York, New York 10019
Braun Music Company, 240 West 55th Street, New York, N. Y. 10019
Braun Music, Inc., 240 West 55th Street, New York, N. Y. 10019
Braun Organization, The, 240 West 55th Street, New York, N. Y. 10019
Brenbar, Box 7001, Tampa, Fla. 33603
Briar Hill, 630 West 246th St., Room 1431, New York, N. Y.
Broadcast, 77 West Washington St., Chicago 2, Ill.
Broadman Press, 127 Ninth Ave., N., Nashville 3, Tenn.
Bronze, 801 16th Avenue, South, Nashville, Tenn. 37203
Brumley, Albert E. & Sons, Powell, Missouri 65730

Canyon, Box 516, Goodlettsville, Tenn.
Capitol, 77 West Washington St., Chicago 2, Ill.
Cardilli, M. V., 351 West 52nd Street, New York, New York 10019
Carlton, 557-59 East 140th St., Cleveland, Ohio 44110
Carter, Roy D., 4115 Vance Road, Fort Worth, Texas 76118
Castion, 2265 Fifth Ave., Apt. M.D., New York, N. Y. 10037
Catholic, 252 Huntington Ave., Boston 15, Mass.
Central, 20209 Labrador St., Chatsworth, Calif. 91311
Century, Inc., 39 West 60th St., New York, N. Y. 10023
Century Press, 412 N. Hudson, Oklahoma City, Okla. 73102
Cerrutti, John M., 351 West 52nd Street, New York, New York 10019
Chantry, Box 425, Fremont, Ohio 43420
Chart, Inc., 1834 Ridge Ave., Evanston; Ill.
Choral, 251 West 19th St., New York, New York 10011
Church, P. O. Box 329, Neosho, Missouri
Circle, 812 16th Ave., South, Nashville, Tenn.
Clayton, Norman J., Winona Lake, Indiana
Clef, 351 West 52nd Street, New York, N. Y. 10019
Clyde's, 726 16th Ave., South, Nashville, Tenn.
Coanacher, B., 1834 Ridge Ave., Evanston, Ill.
Coleman, Robert H., 127 Ninth Ave., N., Nashville 3, Tenn.
Colin, Charles, 315 West 53rd St., New York, N. Y. 10019
Concord, Inc., P. O. Box 1391, Studio City, Calif.
Concordia, 3558 South Jefferson Ave., St. Louis, Mo. 63118
Concourse, 630 West 246th St., Room 1431, New York, New York
Continental, Box 341, Madison, Tenn.
Convention, Inc., Box 3715, Birmingham, Ala.
Convention Press, 127 Ninth Ave., N. Nashville 3, Tenn.
Cooper, Wendell B., and Mrs. Camella, RFD 1, Box 316, Cullman, Alabama
Cooper, W. Oliver, RFD 1, Box 316, Cullman, Alabama
Copley, c/o Pryor, Braun & Cashman, 640 Fifth Ave., New York, New York 10019
Country Gentleman, Powell, Mo. 65730
Crawford, Percy B., 7913 Louise Lane, Wyndmoor, Philadelphia, Pa. 19118
Cummings, M. Homer, 130 Cedar St., Huntington, W. Va. 25705

Daniel, John, 3706C Hillsboro Road, Nashville, Tenn.
Dash, James Allan, 1834 Ridge Ave., Evanston, Ill.
Davis, Marion, Fayette, Alabama
Dawson, William L., P. O. Box 1052, Tuskegee Institute, Ala. 36088
Dean, Emmet, S., P. O. Box 77, Austin 61, Texas
Dean & Edmiaston, P. O. Box 77, Austin 61, Texas
Dean & Evridge, P. O. Box 77, Austin 61, Texas
Dean & Franklin, P. O. Box 77, Austin 61, Texas
Dean & Hensley, P. O. Box 77, Austin 61, Texas
Dean & Morgan, P. O. Box 77, Austin 61, Texas
Dean & Sebren, P. O. Box 77, Austin 61, Texas

Diero, Pietro, 133 Seventh Ave., So., New York, N. Y. 10014
Deiro, Pietro, 133 Seventh Ave., So., New York, N. Y. 10014
Delhi, 440 Main St., Cincinnati, Ohio 45201
Denison, T. S., & Company, 321 Fifth Ave., S., Minneapolis, Minn. 55415
Denson-Parris, Cleveland, Tenn.
Denson Trio, Cleveland, Tenn.
Di Bella, O., 162 East 116th St., New York, N. Y. 10029
Dicker, 26-33 Alderton St., Rego Park, L.I., N. Y.

Ellis, 1645 S. Carson, Tulsa, Okla.
Ellis, V. B. (Vep), 1645 S. Carson, Tulsa, Okla.
Ellis, "Vep" Songs, Briarcliff Hotel, 1050 Ponce de Leon Ave., N.E., Atlanta, Ga. 30383

Fairbank, H. W., 77 West Washington St., Chicago 2, Ill.
Faith Music, Briarcliff Hotel, 1050 Ponce de Leon Ave., N.E., Atlanta, Ga. 30383
Ferrill, J. W., 77 West Washington St., Chicago 2, Ill.
Firm Foundation, P. O. Box 77, Austin 61, Texas
FitzSimons, H. T., 615 N. LaSalle St., Chicago, Ill. 60610
Forecast, 77 West Washington St., Chicago, Ill.
Foreststorn, 3788 Sixth Ave., Los Angeles, Calif. 90018
Fouts, S.G., 428 12th St., Cookeville, Tenn.
Fouts-Payne, 428 12th St., Cookeville, Tenn.
Frador, 133 Seventh Ave., So., New York, New York 10014
Future, 77 West Washington St., Chicago 2, Ill.

Gaines, N. J., 143 Windsor Drive, Muskogee, Okla. 74401
Gaither, William J., P. O. Box 143, Alexandria, Indiana 46001
Gale, 5653 1/2 Hollywood Blvd., Hollywood, Calif. 90028
General Council of the Assemblies of God, 1445 Boonville Ave., Springfield, Mo. 65802
Georgi & Vitak, 4815 South Ashland Ave., Chicago, Ill. 60609
Glaco, Inc., 801 16th Ave., South, Nashville, Tenn.
Golden, 5653 1/2 Hollywood Boulevard, Hollywood, Calif. 90028
Gospel, 77 West Washington St., Chicago 2, Ill.
Gospel, 1445 Boonville Ave., Springfield, Mo. 65802
Gospel Quartet, 386 N. Highland Ave., Memphis, Tenn.
Gospel Songs, c/o Norman Clayton Publishing Co., Winona Lake, Indiana
Grammer, Frank, P. O. Box 329, Neosho, Missouri
Gramophone, 1140 S. Robertson Blvd., Suite 1, Los Angeles, Calif. 90035
Gregorian Institute of America, Inc., 2130-32 Jefferson Ave., Toledo 2, Ohio
Gurley, Robert G., 440 Main Street, Cincinnati, Ohio 45201
Gurley, 440 Main Street, Cincinnati, Ohio 45201

Hackett, Bobby, 34-21 84th Street, Jackson Heights, New York
Hall, Connor B., 897 Trunk St., N. E., Cleveland, Tenn.
Hall House of Harmony, 897 Trunk St., N.E., Cleveland, Tenn.
Hall & McCreary Company, 527 Park Avenue, Minneapolis, Minn. 55415
Hall Music, P. O. Box 636, Maryville, Tenn.
Harbot, 6117 Bresslyn Road, Nashville, Tennessee
Hartford, The, Powell, Missouri 65730
Hart's, 77 West Washington St., Chicago 2, Ill.
Harvest Time, 1217 Weston Drive, Decatur, Georgia
Hathaway, Franklin Earl, 77 West Washington St., Chicago 2, Ill.
Henson, J. M., Briarcliff Hotel, 1050 Ponce de Leon Ave., N. E., Atlanta, Georgia 30383
Heritage, Inc., 29 W. 60th Street, New York, N. Y. 10023
Highland, 1311 N. Highland Ave., Hollywood 28, Calif.
Howlin, P. O. Box 5356, Sherman Oaks, Calif. 91413
Huffer, Fred K., 1834 Ridge Ave., Evanston, Ill.
Huntzinger, R. L., Inc., Lawson Court, P. O. Box 85, Cincinnati, Ohio 45201
Hymntime, 411 Murray Hill Drive, Lancaster, Pa.

Inspiration, Box 13352, Fort Worth 18, Texas

Jaworski-Pandy, 179 Robert Drive, Wapping, Connecticut
Jeffress, Crossett, Arkansas
Jewell, Fred, Worthington, Indiana
Jusko, Ralph, 440 Main Street, Cincinnati, Ohio 45201
Jusko, Ralph, 440 Main St., Cincinnati, Ohio 45201

Ka-Cov, c/o Harry Weber & Co., 271 Madison Ave., New York, N. Y. 10016
Kanner, 74 Riverside Drive, New York, N. Y. 10024
Keene, Hank, 12 El Portal Drive, Jupiter, Florida
Keller, Hal, 6034 Vantage Ave., N. Hollywood, California 91606
Kelman, 470 West End Ave., New York, N. Y.
Kendor, Delevan, New York 14042
Keyboard, 39 West 60th St., New York, N. Y. 10023
King, K. L., Fort Dodge, Iowa 50502
King, 351 West 52nd Street, New York, N. Y. 10019

Kjos, Neil A., 525 Busse Highway, Park Ridge, Ill. 60068
Krone, Max T. & Beatrice P., Box 38, Idyllwild, California

Lair, John, Renfro Valley, Kentucky
Langdon, 1745 Washington Ave., Huntington 4, W. Va.
Le Fevre Trio, Box 400, Atlanta, Georgia 30301
Lena, Suite 507, 1619 Broadway, New York, New York 10019
Lillenas, Box 527, Kansas City, Mo. 64141
Lister, Hovie, Briarcliff Hotel, 1050 Ponce de Leon Avenue, N. E., Atlanta, Ga. 30383
Lister, Mosie, P. O. Box 644, Tampa, Fla. 33601
Lit, c/o Elgart, 55 East 74th St., New York, N. Y. 10021
Littig, Frank, 1834 Ridge Avenue, Evanston, Ill.
Luturgical, 252 Huntington Ave., Boston 15, Mass.
Lloyd, Suite 823, Sunset and Vine Tower, Hollywood, Calif. 90028
Ludwig, 557-59 East 140th St., Cleveland, Ohio 44110
Lutheran Free Church, 426 So. Fifth Street, Minneapolis 15, Minn.

Maricopa, Inc., 713 18th Ave., South, Nashville, Tenn.
Mat-Co, 8890 N. Florida Ave., Tampa, Florida
Mathews, John, 8890 N. Florida Ave., Tampa, Florida
McKinley, 351 West 52nd St., New York, New York 10019
McLaughlin & Reilly, 252 Huntington Ave., Boston 15, Mass.
Melody-Aire, 4145 Kalamazoo, S.E., Grand Rapids, Mich. 49508
Mercury, 17 West 60th Street, New York, N. Y. 10023
Messenger Press, 426 So. Fifth Street, Minneapolis 15, Minn.
Misty, 6034 Vantage Ave., N. Hollywood, Calif. 91606
Moore, David, Powell, Missouri 65730
Morris-Henson, Briarcliff Hotel, 1050 Ponce de Leon Ave., N.E., Atlanta, Ga. 30383
Mosti, Joe, Accordion, 133 Seventh Ave., So., New York, N. Y. 10014
Music Press, P. O. Box 1052, Tuskegee Institute, Ala. 36088
Music Press, Inc., 17 West 60th Street, New York, New York 10023
Music Products, P. O. Box 145, Beaumont, Calif. 92223
Musical Melody, Davis, West Virginia
Musical Window, 720 17th Ave., South Nashville, Tenn. 37203
Musicountry Tunes, 9018 Rangely Ave., Los Angeles 48, Calif.

National Music Company, Route 2, Box 193, Jefferson, Texas 75657
National Music Co., Inc., 77 West Washington St., Chicago 2, Ill.
Natrass-Schenck, 61 So. Division St., New Rochelle, N. Y.
Nazarene, Box 527, Kansas City, Missouri 64141
Nemmers, M. L., 2936 N. Hackett Ave., Milwaukee, Wisc. 53211
Network, 74 Riverside Drive, New York, N. Y. 10024

Ott, Doy, Briarcliff Hotel, 1050 Ponce de Leon Ave., N. E., Atlanta, Ga. 30383

Pagani, O., & Bro., 289 Bleecker St., New York, N. Y. 10014
Pallma, P. O. Box 145, Beaumont, Calif. 92223
Pallma Music Products Corp., P. O. Box 145, Beaumont, Calif. 92223
Pallma, Frank, P. O. Box 145, Beaumont, Calif. 92223
Panella, 273 Clearview Ave., Pittsburgh, Pa. 15205
Paragon, 57 Third Ave., New York, N. Y. 10003
Paris, Oren, Box 13352, Fort Worth 18, Texas
Parks, J. A., 525 Busse Highway, Park Ridge, Ill. 60068
Parris, 916-18 W. Jefferson Blvd., Dallas 8, Texas
Parris, O. A., 916-18 W. Jefferson Blvd. Dallas 8, Texas
Peach, 806 17th Avenue, South, Nashville, Tennessee
Perry, F. Clark, Cleveland, Ohio
Perry's Sons, A. W., 712 S. Kentucky Avenue, Sedalia, Missouri 65301
Peterson, John W., 4145 Kalamazoo, S. E., Grand Rapids, Mich. 49508
Pioneer, 975 South West Temple, Salt Lake City 4, Utah
PJD Music, c/o Mr. Lawrence Uttal, 141 East 88th Street, New York, New York
Podgorski, I., 2233 Orthodox St., Philadelphia 37, Pa.
Pompano, c/o Jack Hooke, 1631 Broadway, New York, N. Y. 10019
Poole, Inc., 11-A Lawyers Building, Greenville, South Carolina
Popular, 77 West Washington St., Chicago 2, Ill.
Porter, Rue, P. O. Box 329, Neosho, Missouri
Pound Ridge, 630 West 246th St., Room 1431, New York, N. Y.

Quartet, 77 West Washington St., Chicago 2, Ill.

Rainbow, 143 Windsor Drive, Muskogee, Okla. 74401
Ramola, 1615 Homewood Place, Dallas, Texas 75224
Ramsey, Will M., 20209 Labrador Street, Chatsworth, Calif. 91311
Ramsey & Parker, P. O. Box 77, Austin 61, Texas

Revival, P. O. Box 16, Searcy, Ark. 72143
Roat, Chas. E. 240 West 55th Street, New York, N. Y. 10019
Rolseth, 240 West 55th Street, New York, N. Y. 10019

Sage and Sound, 5653 1/2 Hollywood Blvd., Hollywood, Calif. 90028
Sajewski, W. H., Inc., 1227 Milwaukee Ave., Chicago 22, Ill.
Schmidt, Arthur P., The, 1834 Ridge Ave., Evanston, Ill.
Schmitt, Hall & McCreary, 527 Park Ave., Minneapolis, Minn. 55415
Schmitt, Paul A., 527 Park Ave., Minneapolis, Minn. 55415
Schmitt Publications, 527 Park Ave., Minneapolis, Minn. 55415
Schuberth, Edward, & Company, 39 West 60th Street, New York, New York 10023
Sebren, George W., Cleveland, Ohio
Select, 77 West Washington St., Chicago 2, Ill.
Showalter, A. J., P. O. Box 77, Austin 61, Texas
Showalter, G.P.H., P. O. Box 77, Austin 61, Texas
Simon, Frank, c/o Southern, 1100 Broadway, P. O. Box 329, San Antonio 6, Texas
Singspiration, 4145 Kalamazoo, S. E., Grand Rapids, Mich. 49508
Sioux Way, c/o Abe Turchin, 200 West 57th Street, New York, N. Y. 10019
Sister, 10 Maple Street, Brooklyn, N. Y. 11225
Skyrite, 209 North Lauderdale, Memphis, Tenn.
Slater, 3520 Boulder Drive, Dallas, Texas 75233
Slaughter, Henry, 1217 Weston Drive, Decatur, Georgia
Slip & Slide, 10 East 49th St., 3rd Floor, New York, N. Y. 10017
Smith, Alfred B., 4145 Kalamazoo, S. E., Grand Rapids, Mich. 49508
Southern, Hal, 5653 1/2 Hollywood Blvd., Hollywood, Calif. 90028
Southern Music Plate, Briarcliff Hotel, 1050 Ponce de Leon Ave., N. E., Atlanta, Georgia 30383
Speer, Ben, P. O. Box 9201, Nashville, Tenn. 37204
Spire, 1846 Westwood Ave., Cincinnati, Ohio 45214
Stamps Quartet, Inc., Box 4366, 916-918 West Jefferson, Dallas, Texas
Standard, 77 West Washington St., Chicago, Illinois
Standard Songs, 77 West Washington St., Chicago, Ill.
Stanphill, Ira, 411 Murray Hill Drive, Lancaster, Pa.
Stirling, 10 Laurel Place, Yonkers, N. Y. 10704
Stoker, 3706C Hillsboro Road, Nashville, Tenn.
Sumner, J. D., 209 North Lauderdale, Memphis, Tenn.
Sunday School Board of the Southern Baptist Convention, 127 Ninth Ave., N., Nashville 3, Tenn.
Sword & Shield, Div. of Wills Family, Inc., 1417 East Abram Street, P. O. Box 211, Arlington, Texas

Tennessee, Cleveland, Tennessee
Thomas, Alvis O., 77 West Washington St., Chicago 2, Ill.
Thomas, J. E., 77 West Washington St., Chicago 2, Ill.
Thompson, Route 5, Box 137B, Lake Charles, Louisiana
Top Music, 74 Riverside Drive, New York, N. Y. 10024
Traficante, 1834 Ridge Ave., Evanston, Ill.
Travelon, 728 16th Ave., South, Nashville, Tenn.
Trio, P. O. Box 77, Austin 61, Texas
Triplett, Bennie S., P. O. Box A, Cleveland, Tenn.

Vaughan, James D., 209 North Lauderdale, Memphis, Tenn.
Velva, 200 East End Ave., New York, N. Y. 10028
Vitak-Elsnic, 4815 South Ashland Ave., Chicago, Ill. 60609

Walls, W. M., P. O. Box 16, Searcy, Ark. 72143
Warde, Harry, 1834 Ridge Ave., Evanston, Ill.
Warner, F. Eugene, 1834 Ridge Ave., Evanston, Ill.
Weaner-Levant, 17 West 60th Street, New York, N. Y. 10023
Weatherington, Jim, Briarcliff Hotel, 1050 Ponce de Leon Ave., N. E., Atlanta, Ga. 30383
Westcott, P. O. Box 7473, 816 East 11th St., Houston, Texas 77008
Western Accordion, 1834 Ridge Ave., Evanston, Ill.
Western Swing, 221 West 4th St., Tulsa, Okla. 74103
Wheelwright, Lorin F., 975 South West Temple, Salt Lake City 4, Utah
Willis, 440 Main Street, Cincinnati, Ohio 45201
Windsor, 77 West Washington St., Chicago 2, Ill.
Winsett, R. E., 128 East 2nd Ave., P. O. Box 327, Dayton, Tenn. 37321
WJB, 250 Tryon Ave., Teaneck, N. J.
Woodard, M. H., 305 First Ave., W., Cullman, Ala. 35055
World Library of Sacred Music, 1846 Westwood Ave., Cincinnati, Ohio 45214

Zellner, Harry, 216 West 102nd St., New York, N. Y. 10025



it's
a
big
small
world...

and our broad and diverse repertory is constantly expanding to meet the demands of new international musical trends and to extend the scope of existing standards.

Through performance and mechanical rights, programing and sales aids to the broadcaster and our special projects department, we are dedicated to serving the needs of the music user everywhere.

SESAC INC.

one of the world's foremost
music licensing organizations



SESAC INC.

CABLE: SESACOM

NEW YORK: 10 COLUMBUS CIRCLE • NEW YORK, NEW YORK 10019 • 212-586-3450
NASHVILLE: 806 16th AVENUE, SOUTH • NASHVILLE, TENNESSEE 37203 • 615-254-5703

A Record To Watch!

FRED FOLEY



"SO LONG, BABY"

31831

Theme from the Ross Hunter Production
"The Art of Love"
A Universal-Ross Hunter-Cherokee Picture



COUNTRY REVIEWS

B+ very good
B good

C+ fair
C mediocre

THE CASH BOX BULLSEYE



BRIGHT LIGHTS AND COUNTRY MUSIC (2:35)
[Moss Rose, Champion BMI—Anderson, Gately]

BORN (2:30) [Moss Rose BMI—Anderson]

BILL ANDERSON (Decca 31825)

Following up his recent charter, "Certain," Bill Anderson should be right back in hitsville with this self-penned deck. The side to watch, "Bright Lights And Country Music," is a rhythmic, stompin' woe-er of a feller trying to wipe out his heartaches with high living. "Born" is a lowdown, forlorn ballad of a man who has heartaches written in his stars.

HELLO VIETNAM (3:06) [New Keys BMI—Hall]

MEXICO CITY (2:00) [Kitty Wells BMI—Anglin]

JOHNNY WRIGHT (Decca 31821)

Not far behind his "Blame It On The Moonlight" success, Johnny Wright aims for a chart position once again with this timely tune, called "Hello Vietnam." The item is a heartfelt, patriotic, chorus-backed ballad of a man ready to leave his home to defend freedom. "Mexico City" is a lilting, happy-sounding ditty about a man heading south to see his woman.

LIVIN' IN A HOUSE FULL OF LOVE (2:12)
[Al Gallico BMI—Sherrill, Sutton]

COWPOKE (2:05) [Al Gallico, BMI—Franks, Houston]

DAVID HOUSTON (Epic 9831)

No newcomer to hitsville, David Houston makes another strong bid for chartdom with this bouncer, titled "Livin' In A House Full Of Love." The tune is a barrellin', high-falutin' rip-snorter about a feller whose dismal life has been brightened up since his gal came along. The flip, "Cowpoke," is a haunting, bittersweet lament of cowboy who's lonely but happy.

JUST A STATE OF MIND (2:33) [Buckhorn BMI—Gantry, Hass]

IT'S ALL OVER NOW, BABY BLUE (2:45)
[Witmark & Sons ASCAP—Dylan]

LEROY VAN DYKE (Warner Bros. 5650)

Vet country chanter Leroy Van Dyke, with lots of hits behind him, should have another money-maker with this lonely sound, called "Just A State Of Mind." Tune is a sad, haunting story of a man who has to leave his woman to follow the call of his wandering feet. The flip, "It's All Over Now, Baby Blue," is a harsh, anti-war, Bob Dylan comp that could make noise in both country and pop areas.

STOP THE WORLD (And Let Me Off) (2:00)
[4 Star Sales BMI—Belew, Stevenson]

THE DARK SIDE OF FAME (2:30) [Harbot BMI—Harris]

WAYLON JENNINGS (RCA Victor 8652)

Waylon Jennings could make a big noise with this catchy number, called "Stop The World (And Let Me Off)." Side is a well-done, contagious heartbreaker of a fella who played the game of love and lost. "The Dark Side Of Fame" is a slowed down, grief-stricken tale of a man who gains recognition but loses the things that really matter.

LET'S WALK AWAY STRANGERS (2:38)
[Cedarwood BMI—Joy, Tillis]

AIN'T LOVE A HURTING THING (2:49) [Pamper BMI—Pennington]

CARL SMITH (Columbia 43361)

Carl Smith should generate plenty of sales excitement with this top-notch outing, dubbed "Let's Walk Away Strangers." This one is a tender, shuffle-beat lament that deals with a feller who's calling a halt to a cheatin' romance. Undercut, "Ain't Love A Hurting Thing," is also a shufflin' weeper with plenty of potential.



WITCHES BREW (2:20) [Dolfi, AMG, ASCAP—Edwards, Joseph]

JOHN BROWN'S TEN LITTLE INDIANS (2:15)
[Dolfi, AMG—Edwards, Joseph]

RUSS EDWARDS (Musicor 1104)

Russ Edwards stands a real good chance to bust out with this fast-moving stanza, titled "Witches Brew." This one is a pounding, light-hearted spiel of a man trying to find a way to win his gal's love. The undercut, "John Brown's Ten Little Indians" is a rollickin', rousin' saga of a man who weds a young Indian maiden and wants a tribe of his own.

JEANNIE SEELY (Challenge 1250)

(B+) WHAT AM I DOING IN YOUR WORLD (2:07) [4 Star Sales BMI—Belew, Bush Moore] Newcomer Jeannie Seely has an excellent femme answer to the current Eddie Arnold giant, and could easily make a national name for herself with this one.

(B+) TODAY IS NOT THE DAY (2:19) [4 Star Sales BMI—Seely, Talley] The lark comes across with more of the same good stuff with this feelingful, dual-track blueser about a gal who can't rid herself of her heartaches.

GRADY MARTIN (Decca 25676)

(B+) FOREVER (2:27) [Tree BMI—Killen] Vet guitarist Grady Martin has come up with an excellent revival of the oldie. Should get plenty of airing on stations and juke boxes.

(B+) RING OF FIRE (2:32) [Painted Desert BMI—Carter, Kilgore] Another topnotch updating on this side. Either lid could make a big breakout.

GINNY WRIGHT (Chart 1250)

(B+) (The Answer To) THE BRIDGE WASHED OUT (2:06) [Peach SESAC—Louis, David, Melshee] Ginny Wright may very well step right into the national spotlight with this impressive answer to the current Warner Mack biggie.

(B+) UNDECIDED (2:21) [Yonah BMI—Josey] Here the lark does a nice job with a real slow, touching tune about a gal who's cheating ways have left her up in the air.

KITTY HAWKINS (Capa 127)

(B+) LOVE ME BEFORE IT'S TOO LATE (2:32) [Law BMI—Allen] Kitty Hawkins shines nicely with this pretty, bittersweet ballad of a gal pleading with her man not to break up their romance.

(B+) MY EVERYTHING (2:21) [Law BMI—Hawkins] This lid is a swaying, self-penned tale of a couple that's forced to break up their illicit affair.

LON COLLINS (Monument 895)

(B+) TWO WORDS ENDED IT ALL (2:23) [Acuff-Rose BMI—Bryant, Bryant] Lon Collins could make a lot of coin with this thumpin', bluegrass-flavored wooser about a fella whose gal has said goodbye.

(B) COMING BACK FOR MORE (2:35) [Pamper BMI—Carter] Flip is a rhythmic, twangy pounder of a man who refuses to be put down by gals' cold shoulder.

SONNY JOE IVY (Jewel 1352)

(B+) TAKE ME BACK (2:06) [Su-Ma BMI—Dupin] Sonny Joe Ivy might get a lot of reaction to this plaintive, heartfelt plea of a man begging for forgiveness from his girl.

(B+) BEGGING FORGIVENESS (2:25) [Su-Ma BMI—Dupin] On this side the chanter comes across with more of the same.

BOBBY LEE TRAMMELL (Sims 8821)

(B+) I TRIED (2:15) [English BMI—Trammell] Bobby Lee Trammell makes a nice effort for attention with this self-penned deck. Top side is a real lowdown, hurtin' tale of a man predicting heartbreak for his fickle gal.

(B) AM I SATISFYING YOU (2:00) [English BMI—Trammell] This one is a hard-paced, twin-market stomper which could attract sales.

JACK CAMPBELL (Jubilee 9008)

(B+) I'LL TRADE MY GAL FOR A TIGER (2:09) [Carwin BMI—French, Campbell] Jack Campbell could get a big reaction to this rompin', stompn' answer to all the smash "tiger" tunes. Lots of potential.

(B+) I GUESS I LEARNED A LOT FROM YOU (2:34) [Carwin BMI—French, Campbell] This side is a slowed down, sentimental, shuffler about a man who's happy with his new love.

JOHNNY SCOGGINS (K-Ark 645)

(B) BABY'S BOSS (2:17) [Moss-Rose BMI—Scoggins] Johnny Scoggins might make some noise with this raunchy, pop-flavored danceable about a man who lets his gal rule the roost.

(B) SICK OF MYSELF (2:03) [Tronic BMI—Scoggins] The flip is a troublin', medium-paced item of a feller who lacks what it takes to be successful.

CECIL BAYSINGER (Nashville 5226)

(B) WHEN THE BUP HITS THE FAN (1:58) [Starday BMI—Ellis, Hill] Cecil Baysinger could grab some spins with this light-hearted, humorous ditty about an inebriated man who wants to get out of sight before his wife finds him.

(C+) THAT'S WHAT MAKES THE JUKE BOX PLAY (2:58) [Acuff-Rose BMI—Work] This side is a downhearted story about what makes the world go round.

Chart Bound!

BILL ANDERSON



"BRIGHT LIGHTS AND COUNTRY MUSIC"

31825



THE BIG THREE

COUNTRY WINNERS IN EACH CATEGORY OF CASH BOX DISK JOCKEY POLL

MOST PROGRAMMED RECORD

1. I'VE GOT A TIGER BY THE TAIL—BUCK OWENS—CAPITOL—BLUEBOOK BMI
2. KING OF THE ROAD—ROGER MILLER—SMASH—TREE BMI
3. ONCE A DAY—CONNIE SMITH—RCA VICTOR MOSS ROSE BMI

MOST PROGRAMMED MALE VOCALIST

1. BUCK OWENS—(CAPITOL)
2. JIM REEVES—(RCA VICTOR)
3. GEORGE JONES—(MUSICOR)

MOST PROGRAMMED VOCAL GROUP

1. THE BROWNS—(RCA VICTOR)
2. WILBURN BROTHERS—(DECCA)
3. FLATT & SCRUGGS—(COLUMBIA)

MOST PROGRAMMED BAND

1. HANK THOMPSON'S BRAZOS VALLEY BOYS—(CAPITOL)
2. LEON McCAULIFFE'S CIMMARON BOYS—(CAPITOL)
3. TEXAS TROUBADORS—(DECCA)

MOST PROMISING MALE VOCALIST

1. DICK CURLESS—(TOWER)
2. RAY PILLOW—(CAPITOL)
3. DEL REEVES—(UNITED ARTISTS)

MOST PROGRAMMED ALBUM

1. I DON'T CARE—BUCK OWENS—(CAPITOL)
2. BEST OF JIM REEVES—JIM REEVES—(RCA VICTOR)
3. I'VE GOT A TIGER BY THE TAIL—BUCK OWENS—(CAPITOL)

Thanks Dee Jays for the LUCKY 13th

For the 13th Year In A Row
#1 Most Programmed Country Band
(Cash Box Disk Jockey Poll—1965)

For the 14th Consecutive Year a
Featured Attraction at the
Texas State Fair



JIM HALSEY ARTIST MANAGEMENT
Agency
PROFESSIONAL BUILDING
INDEPENDENCE, KANSAS
Area Code 316 ED 1-0310 ED 1-3468

current single

**THEN I'LL START
BELIEVING IN YOU**

b/w

IN THE BACK OF YOUR MIND

Capitol #5422

current album

BREAKING IN ANOTHER HEART

(S) T-2274



HANK THOMPSON & HIS BRAZOS VALLEY BOYS

CHET ATKINS

**MOST PROGRAMMED
INSTRUMENTALIST
(PAST 12 MONTHS)**



Chet's great talent keeps him in the winner's circle year after year. Check to be sure you're well stocked up on his chart-climbing single "Yachety Ace" c/w "Letter Edged in Black" (# 8598) and on his most recent album "My Favorite Guitars" (LPM/LSP-3316) A Winner—on **RCA Victor** The most trusted name in sound



THANKS
FOR A
GREAT YEAR

CARL & PEARL BUTLER



AND A SPECIAL THANKS
FOR SPINNING

"JUST THOUGHT I'D LET YOU KNOW"

Columbia 4-43210

AND OUR BRAND NEW ONE

"CAN I DRAW THE LINE"

b/w

"BEERS & TEARS"

COL. 4-43335

MOELLER TALENT AGENCY

Bookings:

W. E. MOELLER, personal direction
815 16th Ave., So. Nashville, Tenn.
phone: 255-6611

Publishing Company:
PEARL DEE
Route 1, Franklin, Tennessee

COLUMBIA 

THE BIG THREE

COUNTRY WINNERS IN EACH CATEGORY
OF CASH BOX' DISK JOCKEY POLL

MOST PROGRAMMED FEMALE VOCALIST

1. LORETTA LYNN-(DECCA)
2. CONNIE SMITH-(RCA VICTOR)
3. KITTY WELLS-(DECCA)

MOST PROGRAMMED INSTRUMENTALIST

1. CHET ATKINS-(RCA VICTOR)
2. FLOYD CRAMER-(RCA VICTOR)
3. PETE DRAKE-(SMASH)

MOST PROMISING FEMALE VOCALIST

1. CONNIE SMITH-(RCA VICTOR)
2. LORENE MANN-(RCA VICTOR)
3. DOTTIE WEST-(RCA VICTOR)

MOST PROMISING INSTRUMENTALIST

1. PHIL BAUGH-(LONGHORN)
2. ROY CLARK-(CAPITOL)
3. PETE DRAKE-(SMASH)

MOST PROMISING VOCAL GROUP

1. GEORGE JONES & GENE PITNEY-(MUSICOR)
2. TOMPALL & THE GLASER BROTHERS-(DECCA)
3. ROY DRUSKY & PRISCILLA MITCHELL-(MERCURY)

MOST PROMISING BAND

1. BUCK OWENS' BUCKAROOS-(CAPITOL)
2. TEXAS TROUBADORS-(DECCA)
3. BLUE BOYS-(RCA VICTOR)

THE BROWNS

MOST PROGRAMMED VOCAL GROUP (PAST 12 MONTHS)



The Browns show why they're such consistent favorites with their new single, "You Can't Grow Peaches on a Cherry Tree" c/w "A Little Too Much to Dream"

[#8603] and with the top-selling album "Three Shades of Brown" [LMP/LSP-2987] A Winner—on

RCA Victor
The most trusted name in sound

THREE SHADES OF BROWN

THE BROWNS

featuring
Jim Edward Brown



COUNTRY POLL WINNERS

COUNTRY RECORDS PLAYED MOST

I'VE GOT A TIGER BY THE TAIL—BUCK OWENS
KING OF THE ROAD—ROGER MILLER
ONCE A DAY—CONNIE SMITH
The Race Is On—George Jones
Dang Me—Roger Miller
I Guess I'm Crazy—Jim Reeves
This Is It—Jim Reeves
Don't Be Angry—Stonewall Jackson
Welcome To My World—Jim Reeves
What's He Doing In My World—Eddy Arnold

COUNTRY ALBUMS

I DON'T CARE—BUCK OWENS
BEST OF JIM REEVES—JIM REEVES
I'VE GOT A TIGER BY THE TAIL—BUCK OWENS
Connie Smith—Connie Smith
Together Again/My Heart Skips A Beat—Buck Owens
Jim Reeves—Jim Reeves
Buck Owens Sings Tommy Collins—Buck Owens
Fabulous Sound Of Flatt & Scruggs—Flatt & Scruggs
Dang Me—Roger Miller
R.F.D.—Marty Robbins

COUNTRY MALE VOCALISTS

BUCK OWENS
JIM REEVES
GEORGE JONES
Roger Miller
Ray Price
Sonny James

Marty Robbins
Johnny Cash
Stonewall Jackson
Eddy Arnold
Jimmy Dean
Carl Smith

COUNTRY FEMALE VOCALISTS

LORETTA LYNN
CONNIE SMITH
KITTY WELLS
Dottie West
Jean Shepard
Norma Jean
Skeeter Davis

Melba Montgomery
Lorene Mann
Patsy Cline
Wanda Jackson
Marion Worth
Jan Howard

COUNTRY VOCAL GROUPS

THE BROWNS
WILBURN BROS.
FLATT & SCRUGGS
Osborne Bros.
Anita Kerr Singers
Sons Of The Pioneers

Glaser Bros.
Willis Bros.
The Jordanaires
Johnny & Jonie Mosby
Carl Butler & Pearl

COUNTRY BANDS

HANK THOMPSON'S BRAZOS VALLEY BOYS
LEON MCCAULIFFE'S CIMMARON BOYS
TEXAS TROUBADORS
Buck Owens & The Buckaroos
Foggy Mountain Boys
Blue Boys
George Jones & The Jones Boys
Judy Lynn Show
Grady Martin
Floyd Cramer

COUNTRY INSTRUMENTALISTS

CHET ATKINS
FLOYD CRAMER
PETE DRAKE
Joe Maphis
Leon McCauliffe
Texas Troubadors

Roy Clark
Phil Baugh
Buddy Emmons
Merle Travis
Don Reno

COUNTRY UP & COMING MALE VOCALISTS

DICK CURLESS
RAY PILLOW
DEL REEVES
Roger Miller
Jack Greene
Don Bowman

Waylon Jennings
Earl Scott
Charlie Louvin
Stan Hitchcock
Johnny Sea
Warner Mack

COUNTRY UP & COMING FEMALE VOCALISTS

CONNIE SMITH
LORENE MANN
DOTTIE WEST
Jody Miller
Jan Howard

Norma Jean
Priscilla Mitchell
Pamela Miller
Loretta Lynn
Wilma Burgess

COUNTRY UP & COMING INSTRUMENTALISTS

PHIL BAUGH
ROY CLARK
PETE DRAKE
Texas Troubadors
Walter Hensley
Rocky Caple
Grady Martin

Buddy Charlton
Bobby Thomas
Boots Randolph
Billy Grammer
Harold Bradley
Curly Fox

COUNTRY UP & COMING BANDS

BUCK OWENS & THE BUCKAROOS
TEXAS TROUBADORS
BLUE BOYS
Jim & Jesse & The Virginia Boys
George Jones & The Jones Boys

Leon McCauliffe's Cimmaron Boys
Hank Thompson's Brazos Valley Boys
Homesteaders
Bill Anderson's Po' Boys
Texas Playboys

COUNTRY UP & COMING VOCAL GROUPS

GEORGE JONES & GENE PITNEY
TOMPALL & THE GLASER BROS.
ROY DRUSKY & PRISCILLA MITCHELL
Osborne Bros.
Ernest Tubb & Loretta Lynn

Blue Boys
Bobby Bare & Skeeter Davis
Johnny & Jonie Mosby
Canadian Sweethearts
Homesteaders
Merle Haggard & Bonnie Owens

CONNIE SMITH



MOST PROMISING FEMALE VOCALIST

The little gal with the big, big talent keeps right on winning more fans and honors! Here are two of the best reasons: Connie's recent single, "I Can't Remember" e/w "Senses" [# 8551] and her exciting album "Connie Smith" [LHM/ LSP-3341] A Winner—on





COUNTRY ROUND UP

There aren't enough days in the year to have a special one for each of our favorite country artists, but once in a while some of our top names are deservedly honored by having their "days." One of the latest to come to our attention was "Bill Anderson Day," held down in the Peach State on July 17 by two all-country stations, WZYX-Atlanta and WAIA-Hapeville. The two outlets devoted the entire day to the chanter's records, topping off the event with a big show in the Atlanta Auditorium, where Anderson and the Po' Boys played to a crowd of 4,000. Another day for the same artist is being planned for Sept. 16 in Commerce, Ga., where he started his career as a deejay. . . . Meanwhile, deejays across the country and even up into Canada, will dedicate Aug. 9th to one of the all-time great country stars, Webb Pierce, who began his big-time career 14 years ago with a little tune called "Wondering," and has been turning out biggies ever since.

Taking a look at our country stations, we notice a bit of shifting here and there. Out at that big West Coast outlet KSON-San Diego, Noel Kelly has been promoted to program director, while vet artist-deejay Texas Bill Strength has been named music director of KTCR-Minneapolis. Smilin' Eddie Briggs has moved out of his deejay chores with KSON and shifted over to spin the music at KUZZ-Bakersfield, and Dusty Miller, who used to handle the country turn table at WCSS-Amsterdam, N.Y., is now taking care of the same duties at WAFS in the same city. And finally, vet newsman Abe Albright has moved from WHEN-Syracuse to WWVA-Wheeling, while Curt Dunn has left his spot with KSNN-Pocatello, Idaho.

It's hard to think of Johnny Cash as being a beginner, but after his recent powerhouse show at Carnegie Hall the artist has been besieged with offers for deals in many areas that are a little new to him. Tops on the list of bids are an offer for the lead in an upcoming Broadway musical and also a shot at a forthcoming TV series. Other deals that call for his attention include plans for a major movie and a possible tour throughout Europe, where his record sales have taken a pronounced upsurge.

Down in Baltimore, WBMD prexy Carl Brenner will be presenting the Fall season series of Country Jubilees, kicking off on Sept. 4 with George Jones and the Jones Boys, Johnny Paycheck, Loretta Lynn, Ray Price and his Cherokee Cowboys, Buddy Emmons, Leroy Van Dyke, Archie

Campbell, Ernest Tubb and his Texas Troubadors, with Buddy Charlton and Jack Green. It looks like a real good show, with four of the top country bands on the stage of the Baltimore Civic Center.

Carlton Haney also has a Labor Day weekend spectacular being set up. This one will be a Bluegrass spectacular and run from Sept. 4-6 at Cantrell's Country Music Park in Finscastle, Va., just outside of Roanoke. Headlining the hoedown will be Bill Monroe &

Russell Sims, head man of the Sims label, seems to have more time on his hands now that he's signed a long-term contract with Atlantic Records for distribution of his catalog. With his extra time he'll now be taking on the promotion for Boone Records, the newly-formed diskery in Union, Ky. The Boone label has had several releases thus far, but it's biggest success to date is Tex Willioiams' biggie, "Too Many Tigers." Owned and operated by Bobby Bobo, the label is open for new talent.



GEORGE JONES



JOHNNY PAYCHECK



WEBB PIERCE

His Bluegrass Boys, Doc Watson, the Osborne Bros., Don Reno and Red Smiley reunited with the Tennessee Cut-Ups, Jimmy Martin & His Sunny Mountain Boys, Mac Wiseman, Howdy Forrester and many surprise guest stars.

All you country deejays out there can do a great service to the industry by sending along your playlists to an ol' buddy of ours by the name of Dick Heard. He's right in the middle of laying the groundwork for a brand new, wide-ranging music service which is due out pretty soon. Among other things, he'll be sampling C & W preferences around the country, so send those station lists to him c/o "For The Record" at 250 W. 57 St., in New York City.

Dan Johnson, general manager of the Atlanta Sound Recording Studios, has dropped a line telling us that he has just signed a five-year production contract with the Ron Blackwood Quartet of Memphis. The studio is now only nine months old, but has already produced 43 albums and is looking to be an all-time great in gospel recording. They picked the right place to start, since Atlanta is considered to be the gospel music center of the world. Lots of luck to the gang down there.

You can't beat the loyal fans of country music for devotion to their artists. For instance, Sandy Orwig and Barbara Huss, both officers of the Bill Phillips Fan Club, had to fly to the aid of their hero a short time ago when the songster was slated to tour the midwest with the Kitty Wells Show. The two Harrisburg, Pa. residents made the trip down to Nashville to "babysit" with Bill's wife Anita, who is recuperating at home from minor throat surgery. A tip of the hat to country music fans . . . long may they reign.

Johnny Talley, sales manager of Ric Records, has informed us that the label will now be handled by Campus Records Distributors in Miami. The label is riding pretty high with Mel Tillis' "Wine," and is also reporting strong reaction to Red Sovine's "Salt On My Eggs."

We'd like to offer our best wishes to a real fine country performer, Porter Wagoner, who'll be celebrating a birthday this week. The hooter will be (???) years old on Aug. 12. (Well, old enough to vote, anyway). Once again, congratulations. Hope there are lots more coming.

We hear from Hank Snow that he has just signed two new artists, Juanita Rose and Patti Kent, to his Silver Star label. Both artists have already been recorded, and the former has just had a release called "A Pillow Filled With Tears." The RCA Victor chanter and his veep-executive manager Troy L. Martin expect big things from both artists.

Ever heard of Paramaribo, Suriname, S.A.?? . . . Neither had the Cedarwood pubbery until it received a letter from Paul Munski, president of the Country Music Organization, requesting the firm's aid in the promotion of country music in Suriname. Munski stated that the CMO has a membership of 250 persons and is growing strong. The publishing house is doing all they can to help the organization and hopes that others will join them. . . . If you give up we'll tell you. The country is Dutch Guiana.

It looks as if Columbia chanter Stonewall Jackson has joined the steady stream of country artists heading for the personal appearance circuit in Europe. Jackson, currently riding on the charts with his new single, "Trouble And Me," will be touring for the first two weeks in Oct. in a deal arranged by his manager, Bob Neal, in cooperation with Hubert Long. Details for his new publishing operation will be announced shortly by the Neal office.



CHECKING IN ADVANCE—Mr. and Mrs. Martin Gilbert of the Gilbert Advertising Agency present Tex Ritter, president of CMA, with a check for \$25,000 as an advance on royalties for the "Country Music Premium" LP while Columbia Records exec Jack Loetz smiles approval.

WE GOT ONE BY THE TAIL!
"THE FRIENDLY UNDERTAKER"

JIM NESBITT

Chart #1240

CHART RECORDS

806 17th Ave., So. Nashville, Tenn.
Peach Music (SESAC)

Many Thanks for your support

PHIL BAUGH

voted

#1

MOST PROMISING INSTRUMENTALIST

(C&W)

by the nation's DJ's in the 1965 Cash Box Disk Jockey Poll

current hit

"Country Guitar"

#559

exclusively on:

LONGHORN RECORDS

2631 Fonville Dr.,
Dallas 27, Tex.



**2 GREAT ACTS!
2 GREAT SONGS!**

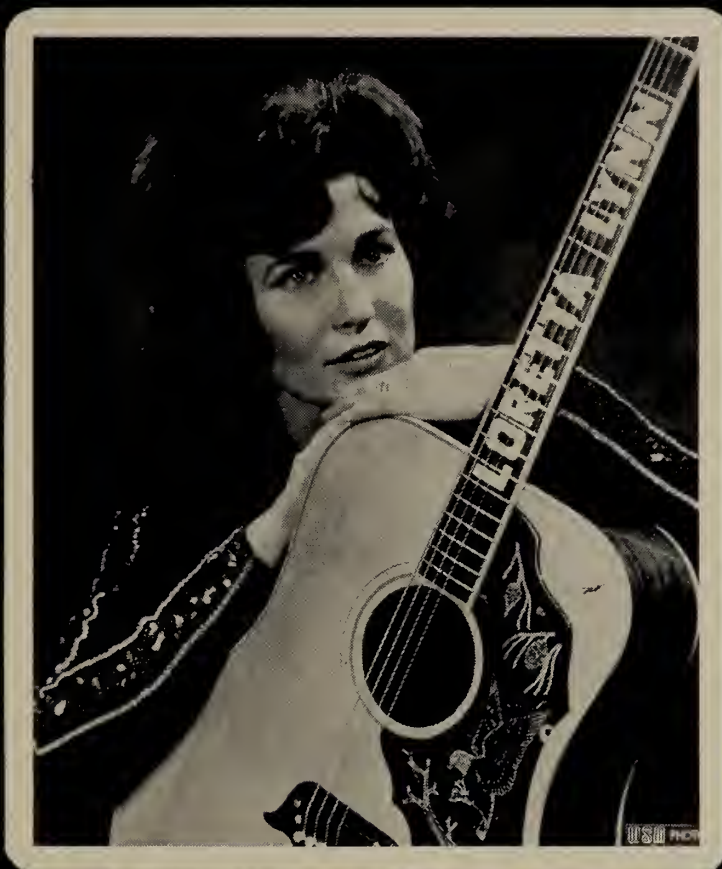

**Loretta *
Lynn**

**"The Home You're
Tearing Down"**

(Decca 31836)

Thanks Dee Jays for Voting Me
#1 Most Programmed Female Vocalist (C&W)
for the 2nd Year in-a-row

***the
Wilburn
Brothers**

It's Another World"

(Decca 31819)



The Wil-Helm Agency

801 - 16th Avenue S. Nashville 4, Tennessee

Ph. - 244-1403





TOP COUNTRY ALBUMS

1	CONNIE SMITH (RCA Victor LPM/LPS 3341)	1	13	FROM THIS PEN Bill Anderson (Decca DL 4646/DL 7 4646)	8
2	I'VE GOT A TIGER BY THE TAIL Buck Owens (Capitol T/ST 2283)	4	14	WESTERN STRINGS Roy Price's Cherokee Cowboys (Columbia CL2339/CS 9139)	22
3	THIRD TIME AROUND Roger Miller (Smash MGS 27068/SRS 67068)	9	15	HANK WILLIAMS SR. & HANK WILLIAMS, JR. (MGM E/SE 4276)	10
4	I'LL KEEP ON HOLDING ON Sonny James (Capitol T/ST 2317)	2	16	SONGS FROM MY HEART Loretta Lynn (Decca DL 4620/7 4620)	17
5	THE JIM REEVES WAY (RCA Victor LPM/LPS 2968)	5	17	HERE COMES MY BABY Dottie West (RCA Victor LPM/LSP 3368)	18
6	EASY WAY Eddy Arnold (RCA Victor LPM/LSP 3361)	3	18	TOMBSTONE EVERY MILE Dick Curless (Tower ST 5005)	19
7	THE RETURN OF ROGER MILLER (Smash MGS 27061/SRS 67061)	7	19	CROSS THE BRAZOS AT WACO Billy Walker (Columbia CL 2331/CS 9131)	21
8	WORLD OF COUNTRY MUSIC Various Artists (Capitol NPB/SNPB 5)	11	20	YOUR CHEATING HEART Soundtrack (MGM E 4260/SE 4260)	13
9	QUEEN OF THE HOUSE Jody Miller (Capitol T/ST 2349)	15	21	ORANGE BLOSSOM SPECIAL Johnny Cash (Columbia CL 2309/CS 9109)	14
10	THE RACE IS ON George Jones (United Artists UAL 3422/UAS 6422)	6	22	BEST OF SKEETER DAVIS (RCA Victor LPM/LSP 3374)	25
11	BLUE KENTUCKY GIRL Loretta Lynn (Decca DL 4665/74665)	16	23	TEN LITTLE BOTTLES Johnny Bond (Starday SLP 333)	23
12	RED ROSES FOR A BLUE LADY George Morgan (Columbia CL 2333/CS 9133)	12	24	MR. & MRS. USED TO BE Loretta Lynn & Ernest Tubb (Decca DL 4639/ DL 74639)	—
			25	COUNTRY GUITAR Phil Baugh (Long Horn LP W 02)	—



COUNTRY TOP 50

		Pos. Last Week			Pos. Last Week
1	THE FIRST THING EVERY MORNING (AND THE LAST THING EVERY NIGHT) (Plainview Music—BMI) Jimmy Dean (Columbia 43263)	1	26	BLUE KENTUCKY GIRL (Sura-Fire—BMI) Loretta Lynn (Decca 31769)	25
2	YES MR. PETERS (Screen Gems-Columbia—BMI) Roy Drusky & Priscilla Mitchell (Mercury 72416)	2	27	YOU CAN GROW PEACHES ON A CHERRY TREE (April—ASCAP) Browns (RCA Victor 8603)	37
3	THE BRIDGE WASHED OUT (Ipeach—SESAC) Warner Mack (Decca 31774)	5	28	WINE (Cedarwood—BMI) Mel Tillis (Ric 158)	20
4	YAKETY AXE (Tree—BMI) Chet Atkins (RCA Victor 8590)	7	29	WILD AS A WILDCAT (Tree—BMI) Charlie Walker (Epic 9799)	21
5	BEFORE YOU GO (Bluebook—BMI) Buck Owens (Capitol 5410)	3	30	BEHIND THE TEAR (Central Songs—BMI) Sonny James (Capitol 5454)	39
6	THE OTHER WOMAN (Pamper—BMI) Ray Price (Columbia 43264)	4	31	THE DAYS GONE BY (S&J—ASCAP) Eddy Arnold (RCA Victor 8632)	40
7	TIGER WOMAN (Al Gallico—BMI) Claude King (Columbia 43298)	8	32	WALKIN' THE FLOOR OVER YOU (Leeds—ASCAP) George Hamilton IV (RCA Victor 8608)	27
8	ONE DYIN' AND A BURYIN' (Tree—BMI) Roger Miller (Smash 1994)	11	33	RIBBON OF DARKNESS (Witmark & Sons—ASCAP) Marty Robbins (Columbia 43258)	28
9	WHAT'S HE DOING IN MY WORLD (4 Star Sales—BMI) Eddy Arnold (RCA Victor 8516)	6	34	THIS IS IT (Acclaim—BMI) Jim Reeves (RCA Victor 8508)	31
10	I CAN'T REMEMBER (Moss-Rose—BMI) Cannie Smith (RCA Victor 8551)	9	35	YOU DON'T HEAR (Johnny Cosh—BMI) Kitty Wells (Decca 31749)	29
11	OUR HEARTS ARE HOLDING HANDS (Moss-Rose—BMI) Ernest Tubb & Loretta Lynn (Decca 31793)	14	36	ONLY YOU (CAN BREAK MY HEART) (Blue Book—BMI) Buck Owens (Capitol 5465)	47
12	AGAIN (Acuff-Rose—BMI) Don Gibson (RCA Victor 8589)	15	37	I'LL KEEP HOLDING ON (Morson—BMI) Sonny James (Capitol 5375)	32
13	IT'S ALRIGHT (Wormwood—BMI) Bobby Bare (RCA Victor 8571)	12	38	GO ON HOME BOY (Acuff-Rose—BMI) Bob Luman (Hickory 1307)	34
14	THAT AIN'T ALL (Acuff-Rose—BMI) John D. Loudermilk (RCA Victor 7579)	16	39	BELLES OF SOUTHERN BELL (Tree—BMI) Del Reeves (United Artists 890)	45
15	ENGINE, ENGINE #9 (Tree—BMI) Roger Miller (Smash 1983)	10	40	I WOULDN'T BUY A USED CAR FROM HIM (Wilderness—BMI) Norma Jean (RCA Victor 8623)	49
16	TRUCK DRIVIN' SON OF A GUN (Raleigh—BMI) Dave Dudley (Mercury 72442)	17	41	TOO MANY TIGERS (Screen Gems-Columbia—BMI) Tex Williams (Boone 1028)	33
17	IS IT REALLY OVER (Tuckohoe—BMI) Jim Reeves (RCA Victor 8625)	36	42	NOTHING LEFT TO LOSE (Husky—BMI) Faron Young (Mercury 72440)	—
18	MR. GARFIELD (Southwind—BMI) Johnny Cosh (Columbia 43313)	19	43	SILVER THREADS AND GOLDEN NEEDLES (Central—BMI) Jody Miller (Capitol 5429)	38
19	HICKTOWN (Central Songs—BMI) Tennessee Ernie Ford (Capitol 5425)	22	44	THE HOBO AND THE ROSE (Cedarwood—BMI) Webb Pierce (Decca 31816)	—
20	COUNTRY GUITAR (Deep Cross Music—BMI) Phil Baugh (Longhorn 559)	13	45	MEANWHILE, DOWN AT JOE'S (Wilderness—BMI) Kitty Wells (Decca 31817)	—
21	I HEARD FROM A MEMORY LAST NIGHT (Rondy-Smith—ASCAP) Jim Edward Brown (RCA Victor 8566)	23	46	CRYSTAL CHANDELIER (Harbol—SESAC) Carl Belew (RCA Victor 8633)	—
22	GREEN, GREEN GRASS OF HOME (Tree—BMI) Porter Wagoner (RCA Victor 8623) Johnny Darrell (United Artists 869)	30	47	TROUBLE AND ME (Forest Hills—BMI) Stonewall Jackson (Columbia 43304)	35
23	DIG, DIG, DIG, DIG (THERE'S NO MORE WATER IN THE WELL) (Lorne Green—BMI) Merle Kilgore (Epic 9816)	26	48	MULE SKINNER BLUES (Peer Int'l—BMI) Hank Williams, Jr. (MGM 13353)	41
24	SIX TIMES A DAY (Aroostook—BMI) Dick Curless (Tower 135)	18	49	THE DEEJAY CRIED (Acuff-Rose—BMI) Ernest Ashworth (Hickory 1325)	—
25	LOUISIANA MAN (Acuff-Rose—BMI) George Jones & Gene Pitney (Musicor 1097)	24	50	HELLO VIET NAM (New Keys—BMI) Johnny Wright (Decca 31821)	—

If you are reading someone else's copy of **Cash Box** why not mail this coupon today!

CASH BOX
1780 BROADWAY
NEW YORK, N. Y. 10019

Enclosed find my check.

\$15 for a full year (52 weeks) subscription (United States, Canada, Mexico)

\$30 for a full year (Airmail United States, Canada, Mexico)

\$30 for a full year (other countries)

\$45 for a full year (Airmail other countries)

NAME

FIRM

ADDRESS

CITY STATE ZIP #

(Check One)

I AM A
DEALER

ONE STOP

DISTRIB

RACK JOBBER

PUBLISHER

RECORD CO.

DISK JOCKEY

COIN FIRM

OTHER

Be Sure To Check Business Classifications Above!



Thank you,
Dee Jays . . .

for voting me
#1

**MOST PROMISING
MALE VOCALIST** (C&W)

DICK CURLESS

current
single

**"SIX
TIMES
A DAY"**

Tower #135
current LP

**"A
TOMBSTONE
EVERY
MILE"**

T (ST) 5005

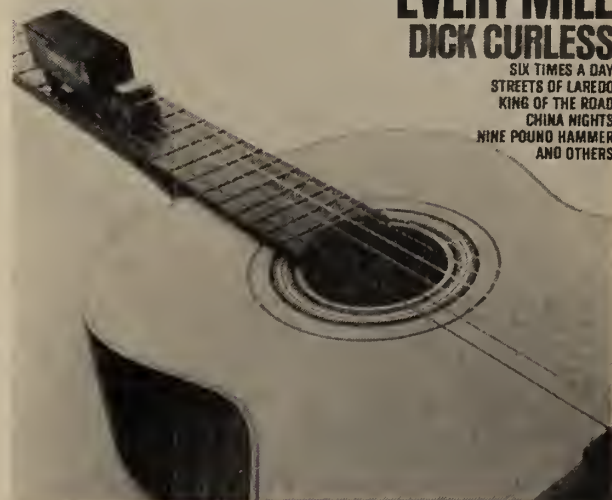

**TOMBSTONE
EVERY MILE
DICK CURLESS**

SIX TIMES A DAY
STREETS OF LAREDO
KING OF THE ROAD
CHINA NIGHTS
NINE POUND HAMMER
AND OTHERS

**THE
DICK CURLESS
SHOW**

P.O. Box 1811
Bangor, Me.
(207) 942-9637

DAN FULKERSON,
Supervisor

Exclusively on



Rolling Stones, Oldham Ink \$1 Mil,

5-Year Pact With British Decca

U.S.-Canadian Deal Expected This Week

NEW YORK—The Rolling Stones and their producer, Andrew Oldham, have re-signed with British Decca in a deal said to guarantee the group \$1 million over a period of five years, the length of the new contract. The agreement is billed as the largest guarantee ever offered an English act.

The new pact covers the entire world, with the exception of the U.S. and Canada. Allen Klein, business rep for the Stones and Oldham, made the deal with British Decca's Sir Edward Lewis.

The big guessing game—expected to be answered this week—is the name

of the label that will release the group's disks in the U.S. It's understood that negotiations are in progress that may well keep the team on the London label, which, of course, is the U.S. affiliate of British Decca. Oldham and two members of the Stones, Mick Jagger and Keith Richard, will join Klein in further discussions here this week.

It's understood that the U.S. deal is closely related to the boys' appearances in films, which would mean that the label which takes on the group would have to agree to help finance film projects featuring the Stones.

'Kapp Is For Profit' Push: 17 New LP's

NEW YORK—Kapp Records has embarked on its "Kapp Is Product For Profit" fall sales campaign, termed "the most extensive and ambitious drive in the company's history." Diskery head Dave Kapp emphasized that the 17 albums unveiled in the program make up "the most well-rounded product we've ever released." Thirteen of the LP's are being issued this month, with the remaining four due to hit the market Sept. 1.

The campaign is being introduced this week in 23 separate presentations throughout the country at distributors warehouses. The unique method of presentation of product, promotion and merchandising plans incorporates both a new method: having four executives get directly to the front line of sales—the distributors and salesmen themselves—via visits to separate regions with synchronized slide and sound equipment to make an individualized presentation; and by use of segments of tape made at the product announcement meeting of the Kapp A&R department in the company's New York offices.

The ad program will focus in a special magazine featuring headlines, copy and cuts of the album covers and prices. All the material is printed on perforated pages enabling the user to make up his own ads. Allowances for advertising are expected to exceed \$300,000 during the life of the program.

Distributors will also receive colorful litho books and sales tip inserts and distributor salesmen will all receive complete album samples at their homes. Special product selections will be sent to dealers and rack jobbers. A complete series of merchandising aids for in-store use is available to retailers. Disk jockeys at most key stations will receive mailed material and samples, supplemented by station mailings from distributor promotion men and Kapp's own field promotion staff.

Special discounts on new and catalog product has been put into effect, and will remain in operation until the end of the year. Also, dated billing arrangements are available with special advertising allowances for both dealers and rack merchandisers.

Phase one of the album release consists of fourteen new packages. Highlighting the new release are Jack Jones' "There's Love and THERE'S LOVE," arranged by Nelson Riddle; "Summer Wind and Your Special Requests" from Roger Williams; and the Do-Re-Mi Children's Chorus in their tenth LP "Playing Games and Having Fun." Also in the new release are: a collection of the year's hits performed by Hugo Winterhalter, a new set from Robertino, a new comedy LP from the producers of "The First Family," entitled "You Don't Have To Be Jewish," an instrumental platter from organist John Gart, the debut of trumpet star Jimmy Sedlar, and a collection of prize-winning Carnival songs from Rio. There are also four c&w packages: Billy Edd Wheeler's newie; "Country Buddies;" a Warner Mack outing; and "Saturday Night at the Old Barn Dance."

The second part of the release, due in Sept., includes efforts from the Searchers, the Waikikis, the Boss Guitars and the Greenwood County Singers.

Handleman Makes 1st Qtr Gains, Shift Mgmt Posts

NEW YORK—A continued trend of growth in sales and earnings was forecast at the Handleman Co. (AMEX) annual stockholder meeting last week in Detroit.

Joseph Handleman, president of the huge rack-jobber, told stockholders: "We expect sales for the first quarter ended July 31, 1965 to increase approximately 15 per cent over the \$6,074,931 reached last year and earnings should be nicely ahead of the \$225,803 or 22¢ per share earned for the same period a year ago." He added, "We anticipate a continued trend of growth in both sales and earnings."

Following the annual meeting a series of top management changes for the company were announced by the board of directors.

Joseph Handleman was elected chairman of the board. Handleman, who was formerly president, will devote his time to "long range planning and to seeking important acquisitions for the company."

Paul Handleman, formerly executive vice-president, was elected president of the company. He will move from Cleveland to the firm's headquarters in Detroit.

David Handleman was elected executive vice-president. He was formerly secretary-treasurer. He is in charge of the record division of the company.

Moe Handleman, formerly vice-president, was elected secretary-treasurer.

Floyd Golden was elected assistant-secretary as was Sophie Kutlov.

Joseph Handleman told stockholders attending the meeting that he expects improved sales and earnings to come from both internal growth from expansion into new geographical markets. He announced Handleman Co. has opened, for the first time, a new branch facility in Los Angeles, Calif. The new branch will initially distribute records in Southern California and then will expand into distribution throughout the West Coast. The new Calif. branch is located at 1550 Knowes St. in Los Angeles. Moe Handleman, newly-elected secretary-treasurer will move from the company's Chicago offices to Los Angeles to direct the western operation.

The exec also announced that the company is going to expand its oper-

(Continued on page 206)

Capitol Fills Mgmt.-Financial Posts

NEW YORK—George R. Jones, vice president of Capitol Records' manufacturing and engineering division, has announced the appointment of Allen W. Murphy, as the firm's national plant controller, effective Aug. 1, 1965.

Murphy, who joined the firm in Jan. 1963, will be responsible for the coordination of the general and cost accounting functions of the three manufacturing plants. He will also act as liaison between the manufacturing and engineering division and other divisions of CRI regarding accounting and related activities. He will report directly to Jones and will continue to maintain his office at the Tower.

In addition, Eugene L. Mueller, general controller of Capitol Records, just announced the following organization appointments:

James E. Fallon joins the firm as director of data processing and James E. Dougherty begins his association with Capitol as director of corporate taxes.

Fallon will be responsible for the direction and coordination of central data processing center operations to provide all data and reports covering accounting and other designated company operations on a national basis. He will also direct the development of new computer programs, EDP systems and applications.

Fallon joins CRI after a six-year association with the County of Orange where he served as director of data processing. He is past president and national director of Data Processing Management Association; a member of the Systems and Procedures Association and the Association for Computer Machinery.

As director of corporate taxes, Dougherty will be responsible for the direction and coordination of all tax activities for CRI, including long-range tax planning.

He comes to Capitol from private practice as an attorney at law in Orange, Cal. where he specialized in the fields of corporate, tax, international business, and real estate law.

Both Dougherty and Fallon will report directly to Mueller.

Mueller also announced the following organizational staff changes within CRI:

P. Vaughn Burdick, executive staff assistant; Lloyd F. Hawe, director of

cost & price analysis; John Macedo, director of corporate accounting; Neil W. Kelly, general auditor; Thomas J. Davis, manager of central data processing.

Mueller advised that the establishment of the organization is designed to provide the company with the most effective financial support, and to assure timeliness and accuracy of documentation as well as full protection of the firm's interests and assets.

Messrs. Burdick, Hawe, Macedo, and Kelly will report directly to Mueller. Davis will report to Fallon.

Vaughn Burdick, as executive staff assistant, will be responsible for the coordination of operations and planning of the general controller's division, and will act as liaison between the general controller and other divisions of CRI. He will conduct special research and make recommendations with respect to finance and other related matters.

Lloyd Hawe, as director of cost and price analysis, will be responsible for the design, formulation and control of cost and inventory accounting systems and accounting procedures. In addition, Hawe will provide financial advice to sales management in the design of sales policies, incentive programs, contests, and all other related financial matters.

John Macedo, as director of corporate accounting, will be responsible for directing and coordinating activities of the corporate accounting group, including general ledger, royalty and license accounting, Hollywood data processing center, and related staff services.

Neil Kelly, in his position as general auditor, will be responsible for conducting audits of all financial and operational activities of the Capitol family of companies. In addition, he will be responsible for the review and analysis of reports of show investment companies, non-consolidated music publishing companies, and other companies where CRI has a financial interest.

Thomas J. Davis, as manager of central data processing, will have responsibility for the operation of the data processing center at Scranton, and will provide technical and administrative support to Fallon in Hollywood.

Enoch Light To Leave Command After Sept.

NEW YORK—Enoch Light, founder and creative head of the Command label, is leaving the diskery at the end of Sept., according to a joint announcement by Light and Larry Newton, president of ABC-Paramount Records.

Light, who sold Grand Award Records, producer of the Command line, to ABC-Par in 1959, said that he will continue in the music and disk producing field. His new activities will be announced around Oct. 1. When he moved over to ABC-Par, Light was named vp of Grand Award and managing director of Command. At the later label, he had a direct hand in the company's various recording projects, including a series of stereo recordings that were the basis of a wave of "sound" LP's in the late 50's and early 60's. He also led an orchestra on a number of best-selling Command albums.

Atlantic Sets Distrib Meet

NEW YORK—Atlantic Records has set dates for its annual Atlantic and Ato distributor sales meetings. The confabs of both of the labels will be held in Chicago at the Continental Plaza Hotel, immediately after the NARM convention. The Atlantic meeting is on Friday (Sept. 10), and the Ato meet is set for Saturday (Sept. 11). New product for the two firms will be introduced, as well as the fall sales plans for the two labels. Attending the meetings will be Atlantic-Ato executives Ahmet Ertegun, Nesuhi Ertegun, Jerry Wexler, Bob Kornheiser, Len Sachs and George Funness. Fieldmen George Bodansky and Clarion Records exec Milt Ross will also attend.

Senate Subcommittee Drops Copy'rt Hearings For Indefinite Period

WASHINGTON—The Senate Judiciary Subcommittee considering the Copyright Bill has postponed hearings on the matter for an indefinite period. Word of the Subcommittee's move came after it had called off hearings scheduled for last Tues. (3) and Wed. (4). Prime reason for the cancellation seems to be the discussion on the floor of the Senate of the proposed amendment to the Constitution involving proportional representation. A House Judiciary Subcommittee has previously conducted hearings on the Copyright Bill.

MPHC Acquires Rights To 'Skyscraper' Score

NEW YORK—Victor Blau, president of Music Publishers Holding Corporation, has announced that the firm has acquired the music from the forthcoming Sammy Cahn and James Van Heusen musical "Skyscraper." Julie Harris and Victor Spinetti will star in the show produced by Feuer and Martin with a book by Peter Stone. "Skyscraper" will play a six week engagement at the Fischer in Detroit prior to its New York opening at the Lunt Fontanne Theatre on October 23. The Harms wing of MPHC will handle the music. Capitol is releasing the soundtrack LP.



CHARTS SCHMARTS

"HANG ON SLOOPY"

by the McCoy's

on **BANG** #506

IS THE HIT!

HERE'S THE ACTION

WIBG—Philly
WAEB—Philly
WPGC—Wash, D.C.
WEAM—Wash, D.C.
KRUX—Phoenix
KDWB—Minneapolis
WDGY—Minneapolis

KXOK—St. Louis
WIL—St. Louis
WLAC—Nashville
WKDA—Nashville
KIMN—Denver
KFWB—Los Angeles
KHJ—Los Angeles

WHK—Cleveland
WKYC—Cleveland
WMCA—New York
WLIB—New York
WNJR—Newark
WFUN—Miami
WPLO—Atlanta

WBZ—Boston
WMEX—Boston
WORC—Worcester, Mass.
WRIT—Milwaukee
WCPO—Cincinnati
WCOL—Columbus
WING—Dayton

WAKR—Akron
WHOT—Youngstown
CKLW—Detroit
WXYZ—Detroit
WICE—Providence
WPRO—Providence
WHYN—Springfield

WPOP—Hartford
WDRC—Hartford
KDKA—Pittsburgh
WAMO—Pittsburgh
KQV—Pittsburgh
WLS—Chicago
WCFL—Chicago
WVON—Chicago



... There's gonna be egg on a lot of faces

when this thing is over. **Sloopy.**

1650 BROADWAY NEW YORK N. Y. 10019 TEL: (201) LT 1-3747



PLATTER SPINNER PATTER

BIOS FOR DEEJAYS

Eddie Hodges



Eddie Hodges, who is presently scoring with "New Orleans" on the Amy/Mala-distributed Aurora label, is a show business veteran even though he's only eighteen years old.

Eddie was first catapulted into the national spotlight via his appearances on the now-defunct "Name That Tune" TV'er a decade ago. His engaging manner and youthful exuberance landed him several important television spots (e.g. "Arthur Godfrey," "Andy Williams," "Pat Boone," etc.) as a singer and entertainer as opposed to a contestant.

In 1957 he widened his horizons and accepted a featured role in the main stem production of "The Music Man." An enthusiastic response from the critics firmly established Eddie as a multi-talented threat.

Since then he has appeared in one other Broadway show, "Critic's Choice," plus several highly-touted flicks including "A Hole In The Head" and "Summer Magic."

David Jones



David Jones, who is currently clicking with his Colpix recording of "What Are We Going To Do," was born seventeen years ago in Manchester, England near the factory where his father worked as an engineer. Davy was just another boy growing up in a big city until he and one of his sisters started entertaining friends and relatives with their concerts. Davy sang while his sister played the piano and it wasn't long before they were starring at local talent shows, church socials and weddings. However, he regarded his performing as a hobby, and he soon left school to train to become a jockey.

The lure of a show biz career was too much, and a short time later Davy started performing on British radio and TV shows. In the spring of 1962 he landed the role of the Artful Dodger in the West End production of "Oliver." He quickly became the toast of London. It was no surprise then when David repeated his British stage success on Broadway that he received the coveted Tony Award for the best supporting actor in a main stem show.

Screen Gems executives saw Davy's performance in "Oliver" and realized how popular he would be with American audiences. As a result he was inked to a TV-flick-recording pact with the company.

Clyde Beatty-Cole Brothers Circus recently lost a hippopotamus while moving from Niagara Falls to Hamburg, N.Y. WEBR-Buffalo morning man Bill Kimble began broadcasting "Lost and Found" announcements until one of his listeners spotted the missing animal, with its tractor-trailer transport and driver in a field. The driver had lost his way the night before and decided to park the rig and wait for daylight. The WEBR listener gave him directions and the hippo arrived in Hamburg in time for the show.

Speaking of personalities, KVI-Seattle has initiated a new one, Namu. Namu is a very unusual personality in that he is an 8,000 pound killer whale. The modern Moby Dick, caught several weeks ago by a pair of Canadian fishermen, was purchased at a dollar a pound by the Seattle Marine Aquarium and was towed 400 miles from British Columbia to Seattle, followed at a safe distance by Mrs. Namu and the two kids. From then on in, the radio station has been keeping a close watch on the progress of the big fish, which, by the way, is the first healthy, unharmed animal of its type ever to be captured. . . . Meanwhile, the

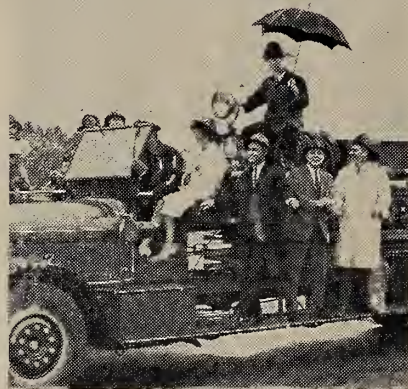

FIREMAN, FIREMAN, SAVE MY CHILD—During Seattle's First Annual Grand Concourse of Antique Fire Apparatus and Firemen's Muster Parade, KING TV and radio personalities decided to hop on the bandwagon and help make the blowout a big success. TV-ites Margy Grennan and Mike Rhodes, along with airmen Tracy Smith and Frosty Fowler (with umbrella), acted as "Honorary Parade Fire Chiefs" while Al Cummings was dubbed "Honorary Fire Captain-Grand Marshal." However, the real highlight of the whole affair was the lineup of over 40 vintage fire-fighting rigs dating back to 1880 including horse-drawn steamers, hook-and-ladder rigs and antique pumpers, which drew a huge crowd to line the shore of Lake Washington for the parade.

Our hearty thanks go out to one of the most important stations in the Los Angeles area, KHJ, for its hour-long salute to Cash Box and the deejays of America, broadcast on Aug. 7. The show, heralded by a week of special announcements, was handled by deejay Robert Morgan and was highlighted by the results of the Cash Box anniversary poll of top record artists. Of course, we must also express our thanks to all the deejays who sent in their returns and made the poll a success. Without your great response, there would be no poll at all.

VITAL STATISTICS:

Alan Henry resigns as veep-general manager of KLAC-Los Angeles. . . . Fred Mac exits WLTH-Gary, Ind. to join the deejay staff at WAAF-Chicago. . . . Johnny Mitchell, former program director and music director with KCBQ-San Diego, moves over to deejay staff with KHJ-Hollywood. . . . Jon Day, ex-staffer with WPOP-Hartford, steps in as program assistant-staff announcer at KRAK-Sacramento.

ATTENTION

RECORD MANUFACTURERS

If you believe in Progress
then have your records distributed by

LAVAL RECORDS, LTD.

649 Beaumont St.
Montreal, Canada

The most progressive distributor
In Canada Today!

Top-notch staff and sales force

We can lease masters to you or from you.

LET'S GROW TOGETHER

Contact: Tony Choma or Dave Grief

CONGRATULATIONS TO CASH BOX

on 23rd Anniversary



MAHALIA JACKSON

Exciting New Album Release!

"THE RUGGED CROSS"

COLUMBIA RECORDS

JODY MILLER - HOME OF THE BRAVE THE BEST RECORD - THE FIRST RECORD!

Already on the air at: WORC Worcester • WMEX Boston • WWOC Washington • WNOE
New Orleans • KBOX Dallas • KNUZ Houston • KBLA Los Angeles • WDRG Hartford

Home Of The Brave (written by Barry
Mann and Cynthia Weil)
b/w This Is The Life
(from "Golden Boy")



5483

JODY MILLER
Home of The Brave 5483 



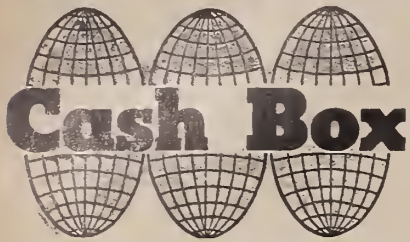

RECORD REVIEWS

• best bet B+ very good B good C+ fair C mediocre

only those records best suited for commercial use are reviewed by Cash Box

Pick of the Week

RIDE AWAY (3:26) [Acuff-Rose, BMI—Orbison, Dees]

WONDERING (2:13) [Acuff-Rose, BMI—Orbison, Dees]

ROY ORBISON (MGM 13386)

Roy Orbison gets his new MGM career off to an excellent start with this initial blockbuster candidate from the label tagged "Ride Away." The side is a rhythmic teen-angled ode about a somewhat ego-oriented lad who cuts-out on romance. "Wondering" is a plaintive, slow-shufflin' country-ish tearjerker.

ROUNABOUT (2:51) [Leeds, ASCAP—Roundabout]

BOSSA NOVA HAND DANCE (2:05)

[Francon, ASCAP—Menezes, Arthur]

CONNIE FRANCIS (MGM 13389)

Deejays will certainly not let this new Connie Francis outing tabbed "Roundabout" pass them by 'cause it has that money-in-the-bank sound plastered all over it. The Tony Hatch-produced date is an easy-going romancer which delineates all of the ambiguities of love. Flip is "Bossa Nova Hand Dance."

MOVE IT ON OVER (2:48) [Vicki, BMI—Shannon, Dennis, Coffey]

SHE STILL REMEMBERS TONY (2:26)

[Vicki & Bright Tunes, BMI—Force, Parson]

DEL SHANNON (Amy 937)

The Amy chanter should really strike paydirt with this top-flight follow-up to his "Break-Up" best-seller called "Move It On Over." The side is rollicking, fast-moving, rhythmic hand-clapper with an extremely contagious multi-dance beat. "She Still Remembers Tony" is a bluesy, medium-paced jumper about a love-sick gal who can't get over her ex-boyfriend.

NERVOUS (2:42) [Burdette, BMI—Whitcomb]

THE END (2:21) [Burdette, BMI—Whitcomb]

IAN WHITCOMB (Tower 155)

Hot-on-the-heels of his "You Turn Me On" smash, Ian Whitcomb comes up with another sure-fire success candidate. This one's called "Nervous" and it's a self-penned low-down, funky romantic blueser delivered in a contagious stammering style by the chanter. The undercut, "The End," is an easy-going heart-throbber about a romance which goes kaput.

CAN'T LET YOU OUT OF MY SIGHT (2:17)

[Screen-Gems, BMI—Miller, Atkins]

DON'T GO (2:48)

[Fleamar & Chuck & Betty, BMI—Simpson, Ashford, Armstead]

CHUCK JACKSON & MAXINE BROWN (Wand 191)

Last-time-out the wax marriage of Chuck Jackson and Maxine Brown resulted in the "Something You've Got" smasher and there's no reason why this potent newie, "Can't Let You Out Of My Sight," can't also become a blockbuster. Side is a rollicking, rhythmic pop-r&b contagious romancer about a very-much-in-love duo who seem aptly suited to each other. "Don't Go" is a plaintive slow-shufflin' tradition-styled blues tearjerker.

HOME OF THE BRAVE (2:50)

[Screen Gems-Columbia, BMI—Mann, Weil]

THIS IS THE LIFE (2:05)

[Morley, ASCAP—Strouse, Adams]

JODY MILLER (Capitol 5483)

HOME OF THE BRAVE (2:50)

[Screen Gems-Columbia, BMI—Mann, Weil]

OUR SONG (2:00)

[Mother Bertha, BMI—Riopell]

BONNIE & TREASURES

(Phi-Dan 5005)

Here are two fine versions of a new Barry Mann-Cynthia Weil message-song tabbed "Home Of The Brave" which both have that money-in-the-bank sound. Jody "Queen Of The House" Miller reads the emotion-packed opus which puts down the philosophy of mass conformity in a blues-drenched slow-moving style while Bonnie and the Treasures, a crew of newcomers, dish-up the tune in rhythmic, rollicking manner enhanced by a rhythmic repeating danceable riff. Take your pick. Jody's coupler is a high-spirited reading of "This Is The Life" from "Golden Boy." The Phi-Dan group back up their "Home" entry with "Our Song," a lyrical easy-going instrumental.

Pick of the Week

SOMEONE IS WATCHING (2:50)

[Web IV-Falart, BMI—Floyd, Isbell, Burke]

DANCE, DANCE, DANCE (2:40) [Cotillion-DeFaith, BMI—Burke]

SOLOMON BURKE (Atlantic 2299)

The vet blues songster can have one of his most successful money-makers in quite a while with this new Atlantic powerhouse tabbed "Someone Is Watching." Tune is a plaintive, slow-moving chorus-backed shuffler about a lad who prays that a very special gal he digs will take notice of him. "Dance, Dance, Dance," is a warm-hearted rhythmic r&b romancer about a fella who has girlfriend who lives for terpsichorean pleasures.

LOVE IS STRANGE (2:50) [Ben Ghazi, ASCAP—Smith]

MAN WITH MONEY (2:17) [Acuff-Rose, BMI—D. & P. Everly]

EVERLY BROS. (Warner Bros. 5649)

The Everly Bros. can certainly get back in their money-making ways with this top-drawer updating of the years-back Mickey and Sylvia smash, "Love Is Strange." The duo reads the bluesy romancer in an affectionate, soulful emotion-packed style. An excellent Top 40 prospect. The undercut, "Man With Money," is a hard-driving original about a poor boy who is in love with a very rich gal.

TOO HOT TO HOLD (2:08)

[Flomar, BMI—Simpson, Ashford, Armstead]

I DIDN'T HURT ANYMORE (2:47)

[Hill & Range, BMI—Robertson, Rollins]

BETTY EVERETT (Vee Jay 8670)

Betty Everett should reach the charts in no time flat with this ultra-commercial Vee Jay release "Too Hot To Hold." The tune is a rhythmic, fast-moving, chorus-backed pop-blues affair about a lass who has a somewhat tempestuous relationship with her fella. "I Didn't Hurt Anymore" is a soulful affair about a lucky girl who finally stops carrying the torch for her ex-guy.

I'M LIVING GOOD [Fame, BMI—Penn, Oldham]

RECIPE FOR LOVE [Rise, BMI—Yates]

OVATIONS (Goldwax 117)

The Ovations made a big sales-splash with their first effort, "It's Wonderful To Be In Love," in both the pop and r&b markets and this blue-ribbon follow-up should have no difficulty in reaching the winner's circle. The "A" side, "I'm Living Good," is an easy-going, laconic ode about a lucky guy who doesn't need any money 'cause he's met the girl of his dreams. "Recipe For Love" is a catchy, medium-paced warm-hearted blues romancer.

I WON'T BE BACK THIS YEAR (2:38) [Regent, BMI—Kusik, Lorber]

YOUNG HEARTS (1:58) [Judy-Jim & Florentine, BMI—Wray]

JIMMY VELVET (Philips 40314)

Jimmy Velvet, who clicked recently with "It's Almost Tomorrow," can well go the whole chart-distance with this power-packed Philips release tabbed "I Won't Be Back This Year." The tune is a tender, slow-moving countryish weeper about an unfortunate lad who has to leave his gal because he found a job out of town. "Young Hearts" is a pretty, medium-paced teen-angled romancer with a nostalgic years-back sound.

HEY HO WHAT YOU DO TO ME (2:10)

[Flomar, BMI—Simpson, Ashford, Armstead]

GOODNIGHT GOODNIGHT (2:25)

[Expressions & Flomar, BMI—R. & R. Bachman]

GUESS WHO (Scepter 12108)

The Guess Who are a natural to repeat the success of their recent hit, "Shakin' All Over," with this excellent item labeled "Hey Ho What You Do To Me." The tune is a rollicking, fast-moving, rhythmic high-spirited romancer about a guy who is on cloud nine ever since he met his girl. "Goodnight Goodnight" is a raunchy, feelingfully essayed lament about a love gone wrong.

Newcomer Pick

YOU DON'T KNOW (3:00) [Trio, BMI—Barry, Greenwich, Morton]

BABY (2:20) [Trio, BMI—Barry, Greenwich, Morton]

ELLIE GREENWICH (Red Bird 10-034)

The wife half of the hot cleffing team of Barry and Greenwich makes an auspicious bow as a vocalist on this most impressive Red Bird entry called "You Don't Know." The tune is a blues-tinged effectively-building lament about a gal who is still hung-up on her ex-boyfriend even though he rejected her. "Baby" is a catchy, chorus-backed multi-beat happy-go-lucky teen romancer.

ROSES & RAINBOWS

**DANNY
HUTTON**

HBR-447

B/W MONSTER SHINDIG

**ACTION
ACTION
ACTION**

TWO, (COUNT 'EM, 2)-BIG ACTION RECORDS FROM "HBR" WITH NATIONWIDE TV EXPOSURE: LLOYD THAXTON □ SHINDIG □ HOLLYWOOD A-GO GO □ WHERE THE ACTION IS □ 9th STREET WEST □ AMERICAN BANDSTAND.

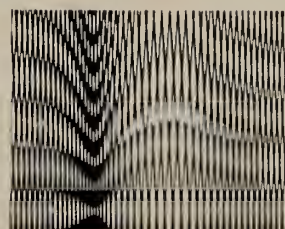

HBR®

HANNA-BARBERA RECORDS
3400 CAHUENGA BLVD. HOLLYWOOD, CALIFORNIA



**I
DON'T
BELIEVE**

the
GUILLOTEENS
HBR 446
B/W HEY YOU



RECORD REVIEWS

● best bet B+ very good B good C+ fair C mediocre

only those records best suited for commercial use are reviewed by Cash Box

Newcomer Pick

THE GIRL IN THE BLACK BIKINI (2:51)
[Mimosa & JDA BMI—Duncan]

DO THE SURFER JERK (2:08) [Mimosa & JDA BMI—Duncan]
IN CROWD (Musicor 1111)

The In Crowd should move swiftly up the charts with this seasonal-themed Musicor bow named "The Girl In The Black Bikini." Tune is a lyrical, slow-moving heart-throbbing ode done in a harmony-and-counterpoint Beach Boys style about a lass who mourns her surfin' fella who will never return. "Do The Surfer Jerk" is a rollicking, fast-moving rhythmic affair which intros a new teen dance.

THE COLOR OF HIS LOVE IS BLUE (2:30)
[Central Songs, BMI—Stone, Turner]

DRIVING WHEELS (1:53) [Lion, BMI—Wainwright, Wyler]
ODESSA HARRIS (Uptown 711)

Odessa Harris can establish both herself and the Uptown label with this excellent blues-treatment of Roy Clark's while-back "The Color Of His Love Is Blue." The side is a slow-shufflin' funky after-hours romantic lament which builds to a dramatic emotion-packed pitch. Coupler, "Driving Wheels," is a low-down, rhythmic traditional blues weeper.

HURT ME TO MY SOUL (2:28) [Harmony Hill, ASCAP—Peabody]
THAT'S WHERE LOVE HAS GONE (2:47)
[Harmony & Emjay, ASCAP—Peabody]
FIRST FOUR (Strata 103)

The First Four have an excellent chance of establishing national reputations as 'record salesmen' on this basis of top-rung Strata release tabbed "Hurt Me To My Soul." The tune is a blues-drenched lament about a romance which ends up on the rocks with a contagious repeating rhythmic riff. Blockbuster potential here. Flip, "That's Where Love Has Gone," is a slow-moving folkish affair with a hauntingly pretty melodic undercurrent.

Best Bets

JONATHAN KING (Parrot 9774)

● EVERYONE'S GONE TO THE MOON (2:30) [Mainstay BMI—King] Newcomer Jonathan King should attract the fancy of many a deejay with this lovely, slow-moving lyrical ballad which describes in rather plaintive terms how life has changed because of the Atomic Age.

(B+) SUMMER'S COMING (2:30) [Mainstay BMI—King] Pretty, seasonal-themed romancer sold with loads of poise by the chanter

HERB ALPERT (A&M 775)

● 3rd MAN THEME (2:29) [Chappell ASCAP—Krans] Herb Alpert can get some new sales-mileage out of the haunting flick theme. The orkster, along with the Tijuana Brass, swings up a storm and gives the familiar item a fresh high-spirited flavor. Loads of programming appeal.

(B+) TASTE OF HONEY (2:43) [Songfest ASCAP—Scott, Marlow] Lilted reading of the bluesy film theme.

BUBBLES & CO. (Blue Cat 120)

● UNDERNEATH MY PILLOW (2:58) [Essex BMI—Van Dyke] Here's a catchy, easy-going lyrical British affair about a lad who spends most of his nights dreaming about a gal who doesn't even know that he exists. Could become a giant.

(B+) JUST ONE GIRL (3:02) [Roar BMI—Fennings] Tender, slow-moving emotion-packed teen romancer.

TOMMY ROE (abc 10706)

● WISH YOU DIDN'T HAVE TO GO (2:15) [Fame BMI—Penn, Oldham] Tommy Roe has a good chance of hitting the charts with this easy-going, chorus-backed romantic ode about a love-sick fella who tries to convince his gal to stay out a little longer with him. A real nice effort.

(B+) I KEEP REMEMBERING (THINGS I FORGOT) (2:40) [Unart BMI—Buie, Adkins] Low-down blues-drenched heart-throber.

LEE GARRETT (World Artists 1061)

● I NEED SOMEBODY (3:20) [Screen Gems—Columbia BMI—Fisher] Lee Garrett can quickly zoom up the hitsville path with this top-rung tender, slow-shufflin' chorus-backed pop-r&b plea for romance which effectively builds to an exciting dramatic pitch. Wide-spread appeal here.

(B+) SO FAR AWAY (2:55) [Screen Gems BMI—Fisher, Boggess] Plaintive, tradition-styled blues tale of woe.

SAM & BILL (Joda 100)

● FOR YOUR LOVE (2:47) [Beechwood BMI—Townsend] Sam and Bill get their Joda career off to a flying start with this soulful, slow-shufflin' item about a love-sick fella who claims that he'll do anything for the girl of his dreams. Both pop and r&b potential here.

(B+) BEAUTIFUL BABY (2:45) [And BMI—Nash, Gary Johnson] Catchy, low-down funky pledge of devotion.

Best Bets

ZENA FOSTER (Veep 1222)

● MAKE IT ME (2:39) [RK, BMI—Adams, Kusik] Zena Foster turns on a powerhouse of blues charm in this potent reading of a solid r&b sound. The tune features a catchy shuffle appeal with mid-tempo dance beat, and her vocal could turn this into a sizeable sales item.

(B+) BABY, LET ME TEACH YOU (2:21) [RK BMI—Adams, Kusik] Up-tempo throber.

GARY FARR AND THE T-BONES (Epic 9832)

● GIVE ALL SHE'S GOT (2:43) [B. Feldman ASCAP—Mason, Beades] Low down English-blues orking and a solid sounding vocal team up to form a sound that could capture the market on both pop and r&b fronts. Nice build at the close of each stanza on a fine sounding effort.

(B+) DON'T STOP AND STARE (2:29) [B. Feldman ASCAP—T-Bones] Steady paced rocker.

BOBBY LILE (Almo 227)

● MAN OF THE WORLD (2:35) [Kavelin-Rollo BMI—Lile] Pounding semi-English orking with a light trace of Latin flavoring makes for fine listening on this dance angled side in a rockable way. Nifty teen tilted lyrics should add to the sales impact.

(B+) (I'M GONNA) BREAKAWAY (2:15) [Irving/Kavelin-Rollo BMI—Lile] Off-beat stomper.

IVY LEAGUE (Cameo 377)

● TOSSING & TURNING (2:25) [Southern ASCAP—Carter, Lewis, Ford] Flashy orking and a lively stylish group sound could make a big showing on this carefree bouncing ditty. The Ivy League is likely to push its way up the pop charts via this deck.

(B+) GRADUATION DAY (2:16) [Southern ASCAP—Carter, Lewis, Ford] Four Seasons-y romp here.

BROUGES (Twilight 408)

● BUY NOW I FIND (2:15) [Duane BMI—Campbell, Elmore] The Brouges are already getting some spins with this first-rate Mersey Beat affair and the side could well go the whole chart distance. Tune is hard-driving raunchy blueser about an unfortunate lad who has problems with an unfaithful gal.

(B+) SOMEDAY (2:13) [Duane BMI—Rodrigues] Quick-paced item about a guy who thinks that he's not good enough for his girl.

PETE FOUNTAIN (Coral 62460)

● THE WHIFFENPOOF SONG (2:32) [Miller ASCAP—Minigerode, Pommeroy, Galloway] The vet instrumentalist is sure to get some middle-of-the-road and Top 40 spins with this impressive re-working of the Rudy Vallee-associated sturdie. Fountain's mellow clarinet is effectively spotlighted in a lush orchestral setting nicely enhanced by a wordless chorus.

(B+) RAVE ON (1:46) [Garpax BMI—Paxton] Clever, catchy, teen-oriented instrumental.

AL McCARTHER (Two Guitars 900)

● HIS TRUE LOVE FOR YOU (2:40) [Roosevelt, BMI—Daryll, Taylor] This lightly shuffling ditty spiced with a bit of Latin-jazz flutework comes on strong with a sweet vocal from Al McCarther. The side is a good shot for spinning and could grab a chunk of the teen market.

(B+) IN THIS ROOM (2:01) [Two Guitars, BMI—Taylor, Daryll] Soft ballad.

TULIPS (MGM K 13375)

● YOU BETTER STAY AWAY FROM MY BABY (2:14) [Wanessa, BMI, Allen, Merrell] The Tulips could plant roots on the top 100 charts and find this pleasant moving finger snapping shuffler growing on the teens. Watch for a solid deejay and teen response.

(B+) HOLD ME CLOSE (2:27) [T.M., BMI—Clark] Ballad in the blues vein.

DENNA JOHNSON & RICKY DAVIS (Simpson 101)

● THERE'S GONNA BE A SHOWDOWN (2:08) [Simco, BMI—Herring] Both artists turn in fine showings on this mid-tempo with gobs of r&b appeal. The side has dance and lyrical draw that could send it well on its way up to the blues charts with pop following possible.

(B+) WHO ME? YEAH YOU! (2:10) [Galrek, BMI—Herring, Steward, Simpson] Pounding multi-dance stomper.

CORKY WILKIE (HBR 448)

● LITTLE BY LITTLE (2:03) [Leeds BMI—Mills] Platter spinners should speedily add this fine affair to their playlists. Side is a rollicking, fast-moving, pop-blues thumper about a fella who thinks that every romantic situation should be taken one step at a time.

(B+) SOMETHING SWINGING (2:05) [Anihanbar & Triffid BMI—Ayres] Extremely funky slow-moving instrumental stanza.

JOE SOUTH (Apt 25084)

● I WANT SOMEBODY (2:53) [Lowery BMI—South] Joe South can well do Top 100 biz with this potent blueser about a determined guy who wants to become famous so the very special girl that he digs will respect him. A standout performance.

(B+) DEEP INSIDE ME (2:25) [Lowery BMI—South] Easy-going, laconic tale of heartbreak sold with poise and feeling by South.

LIVERPOOL SET (Columbia 43351)

● MUST I TELL YOU (I LOVE YOU) (2:26) [Red River, BMI—Lancing, Donnell] Slow shuffle sounds and a rock-a-cha beat make for easy listening on this softly sung English sounder. Has enough of what it takes to catch fire. Keep an eye on this one.

(B+) MISS YOU SO (2:35) [Blackwood, BMI—Lancing, Hunt] Scintillating ballad.

OUR SYMPATHY TO
"THE GIRL IN THE BLACK BIKINI"
WHO LOST HER LOVER IN THE SURF AT MALIBU



HOLD YOUR OWN SERVICES AT YOUR LOCAL BEACH

MUSICOR RECORD NO. 1111



RECORD REVIEWS

● best bet B+ very good B good C+ fair C mediocre

only those records best suited for commercial use are reviewed by Cash Box

Best Bets

CLAY HUNT (Kapp 695)

● **IN THE CITY SQUARE** (2:26) [Ken Kirk BMI—Fann] Newcomer Clay Hunt could well score in the loot dept. with this fast-moving, chorus-backed hand-clappin' pop-r&b affair with a real infectious rhythmic multi-dance teen-oriented beat. Eye it.

(B+) **SINCE I'VE LOST YOU** (2:38) [Jobete BMI—Whitfield] Laconic, shuffle-beat blues-drenched tale of remorse.

NANCY ADAMS (RCA Victor 8650)

● **I'M GONNA BUILD A FENCE** (2:26) [Miniature Musicals ASCAP—Huddleston] Nancy Adams can finally establish herself sales-wise with this easy-going, chorus-backed updating of the romantic evergreen about a gal who has no intention of letting anyone else get a chance to steal her fella away from her.

(B+) **GO ON!** (2:40) [Devon BMI—Barkan] Plaintive, medium-paced country-ish ode.

JAMES GRESHAM (Decca 31832)

● **WHAT DID I DO** (2:11) [Vendo BMI—Gresham] Here's an attractive pop-r&b item which stands a good chance of garnering plenty of airplay activity. Side is a rhythmic lament about a confused guy who can't understand why his romance is turning sour.

(B+) **MR. WIND** (2:37) [Vendo BMI—Avery] Effective inspirational soulfully read by Gresham.

KAREN KELLY (Sound 7 Stage 2544)

● **PARTY TALK** (2:31) [Tamrose BMI—Carson, Hampton] Karen Kelly unleashes her potent, wide-range vocal talents full-blast on this rollicking, dual-track teen-oriented ode which claims that some boys don't reveal their true feelings in a party setting. Immediate response indicated here.

(B+) **HE PASSES BY** (2:26) [Screen Gems—Columbia BMI—Lee, Reynolds] Interesting item about a gal who wishes that a special fella she digs will notice her.

OLYMPICS (Loma 2017)

● **BABY I'M YOURS** (2:25) [Regent BMI—Elgin] The Olympics have had pop-r&b hits in the past and they can score again with this tender, slow-shufflin' about a love-sick guy who has a real hard time getting through his days without his gal. Watch it.

(B+) **NO MORE WILL I CRY** (2:55) [Towles & Aries BMI—Shaw] Raunchy, hard-driving traditional blues weeper.

OVERLANDERS (Hickory 1327)

● **RAINBOW** (2:29) [Leeds ASCAP—Mason, Bartholomew, Friswell] The Overlanders can speedily move up the hitsville path with this hauntingly lovely English item which takes a somewhat euphoric viewpoint on modern life.

(B+) **TAKE THE BUCKET TO THE WELL** (1:53) [Acuff-Rose BMI—Stough, Rainwater] Clever, medium-paced country-ish romancer.

BERNARD CRIBBENS (United Artists 907)

● **RIGHT, SAID FRED** (2:20) [Unart BMI—Dicks, Rudge] Newcomer Bernard Cribbens can create a sales stir on the basis of this easy-going happy-go-lucky novelty rendered in an infectious Midlands accent. Deejays should really dig it.

(B+) **QUIETLY BONKERS** (2:02) [Noel Gray BMI—Dicks, Rudge] Catchy, British music hall-type romancer.

FIVE EMPREES (Freeport 1001)

● **LITTLE MISS SAD** (2:15) [Radford BMI—D. & D. Ad-drisi] The Five Empees are an odds-on bet to have hit on their hands with this rollicking, fast-moving bluesey opus with a contagious multi-beat danceable beat. Loads of potential here.

(B+) **HEY LOVER** (2:46) [Roosvelt BMI—Berry, Covay] Moody, slow-moving pledge of romantic devotion.

BARONETS (Vee Jay 701)

● **THAT'S THE WAY LOVE HAPPENS** (2:25) [Saturday BMI—Cane] The Baronets are destined to make national names for themselves with this rhythmic, medium-paced twister which claims that everything turns out all right when a couple is in love.

(B+) **MINE ALL MINE** (2:10) [7th Ave. Music BMI—Kasha, Thomas] Mersey Beatish teen-angled romancer.

D MEN (Kapp 691)

● **SO LITTLE TIME** (2:16) [Waterview, Ashland, BMI—Askew, Wadhams, Gavin] The wild ork opening and catchy group work on this mid-tempo, low-keyed driving side could snag plenty of spins and sales in the rock field. Kevin Gavin gets production credit on the fine side.

(B+) **EVERY MINUTE OF EVERY DAY** (2:37) [Waterview, Ashland, BMI—Askew, Wadhams, Gavin] Nifty light-hearted romp.

STEVIE WONDER (Tamla 54119)

● **HIGH HEEL SNEAKERS** (2:58) [Medal, Higgenbotham] Culled from the "Motortown Review In Paris" LP, this up-tempo mover could put Stevie Wonder back on the pop charts. The side features a 'live' driving reading of the blues tune which hit about a year back for Tommy Tucker.

(B+) **MUSIC TALK** (2:57) [Jobete, BMI—Hull, Paul, Wonder] Low down throbber.

VEJTABLES (Autumn 15)

● **I STILL LOVE YOU** (2:22) [Taracrest, BMI—Errico, Ashton] Sad lyrics set to a happy bouncing beat make for interesting material on this side, one that should find a welcome from many deejays. Could break wide open, heading up the hitsville path.

(B+) **ANYTHING** (2:22) [Taracrest, BMI—Bailey] Hefty beat on this semi-English styled side.

Best Bets

ROGER MILLER (RCA Victor 8651)

● **IF YOU WANT ME TO** (1:53) [Tree BMI—Miller] Roger Miller can create a lot of noise with this infectious pop-country ditty which was cut during the chanter's stint with Victor. Side is a warm-hearted, dual-track romantic opus about a fella who is head-over-heels in love with his girlfriend.

(B+) **HEY LITTLE STAR** (2:22) [Tree BMI—Miller] Pleasant low-key reading of Miller's old c&w hit.

LINDA GAYLE (Columbia 43359)

● **STOP, LOOK, LISTEN** (1:50) [Hill & Range, BMI—Byers] Potent driving pseudo-jug band blues bounce on this deck provides it with an unusual flavoring that could catch the extra attention needed to send it way into the winner's listings. May crack wide open.

(B+) **GOODNIGHT, IRENE** (2:18) [Ludlow, BMI—Ledbetter, Lomax] Up-tempo shuffle version of the folk standard.

LYN ROMAN (Mercury 72473)

● **G. B. DAY** (2:34) [Wellmade, Leatherneck, BMI—Ott] This catchy shuffle blueser packs a finely building sound with some great singing in an effort that could well attract loads of attention in the r&b and pop marketplace. The Ed Townsend produced deck may click.

(B) **MY LIFE STORY** (2:56) [Leatherneck, BMI—Townsend] Unusual ballad.

GEORGE SMITH (Turntable 713)

● **I'VE HAD IT** (2:30) [Benny Benjamin, ASCAP—Benjamin, Marcus] Smooth bluesy vocal and interesting orking on this fine tune could send the side skyrocketing on both the pop and r&b fronts. Good production work by Earle Robinson, with fine arrangements from Dave Ward.

(B+) **WHEN LOVE TURNS TO PITY** (2:07) [Joy, ASCAP—Lee, Goehring] Soft shuffle ballad.

LEMME B. GOOD (Mercury 72470)

● **I CAN'T STOP MYSELF** (2:48) [Southern, ASCAP—Carter, Lewis] Slow, steady throbbing beat and a somewhat plaintive vocal team up to form a sound that could take the r&b areas by storm and carry plenty of pop sales as well. Merits close attention for possible break.

(B+) **MOTHER MAY I** (2:55) [MRC, BMI—Good, Lantz] Cute lyrics on this jerk tune.

GARY BONDS (Legrand 1039)

● **DO THE BUMPSIE** (2:24) [Rockmasters, BMI—Guilda, Butts] Solid beat rhythm and driving ork sounds have created clicks for Gary Bonds before, and he may well pop back in the spotlight via this outing in his familiar style. Merits attention.

(B+) **BEACHES, U.S.A.** (3:04) [Rockmasters, BMI—Guilda, Anderson] More move music.

B+ REVIEWS

LITTLE ROSE LITTLE (Blue Rock 4022)

(B+) **PAPA, DON'T YOU WORRY 'BOUT YOUR DAUGHTER** (2:25) [Anita, MRC, BMI—Watts, Davis] Soulful blues chant.

(B+) **BYE BYE BIG BOY** (2:43) [Edwin H. Morris, ASCAP—Ballard, Jr.] Ballad throbber.

SPATS (ABC Paramount 10711)

(B+) **GO GO YAMAHA** (2:00) [Lansdowne, Winston, ASCAP—Mace, Renard] Hot rod-surf sound.

(B+) **HAVE YOU EVER SEEN ME CRYING?** (2:29) [Lansdowne, Winston, ASCAP—B. Johnson, D. Johnson] Pretty ballad with subdued build.

EASTSIDE KIDS (Philips 40295)

(B+) **SUBWAY TRAIN** (2:02) [Ra-leigh, BMI—Gentile, Moehrl, Carl] Clever Shuffle-rock instrumental.

(B) **SUNDAY STRANGER** (2:23) [Metric, BMI—Strange] Up-tempo mover.

KINGS AND QUEENS (Ascot 2185)

(B+) **I CAN FEEL IT** (2:36) [Meager, BMI—King] Good beat r&b item.

(B) **STUCK IN THE MUD** (2:25) [Meager, BMI—King] Blues with a Coasters-like sound.

GEORGE McCANNON (Fun '45 008)

(B+) **SEVEN MILLION PEOPLE** [(2:15) Screen Gems—Columbia, BMI—Greenfield, Miller] Big bouncy ballad.

(B+) **YOU CAN'T GROW PEACHES ON A CHERRY TREE** (2:31) [April, ASCAP—Levitt, Gargoni] Similar stuff with a country flavor.

DENNIS JONES (Plug 3226)

(B+) **THIS IS THE TIME** (2:09) [White Orchid, BMI—Jones] Bluesy side with potent vocal showing.

(B+) **I CAN'T UNDERSTAND IT** (2:20) [White Orchid, BMI—Jones] More of the same.

PATTI DREW (Quill 101)

(B+) **WHERE IS DADDY?** (2:58) [Shapiro, Bernstein, ASCAP—Randell, Pelaez, Puglisi] Slow blues lament.

(B+) **SUFFER** (2:10) [Camelback Mountain, ASCAP—Ballard, Jr., Riela] Up-tempo blues-waltz.

LEADERS (Fontana 1519)

(B+) **NIGHT PEOPLE** (2:24) [Painted Desert, BMI—Spencer, Cooper, D'Errico, Rabbit] Catchy semi-English stomper.

(B) **LOVE WILL FIND A WAY** (2:19) [Painted Desert, BMI—Marcs, Spindel] Soft ballad.

Evitez les Confusions
(Avoid Confusion)

This ad is being taken out
in behalf of the original
recording of
"HOME OF THE BRAVE"
by BONNIE & THE TREASURES
on PHI DAN Records #5005-
a master which I purchased.
To avoid any confusion, there
is no doubt that this is
the original recording and
original creativity is still the
backbone of our industry,
isn't it?

Thanks,
PHIL SPECTOR



RECORD REVIEWS

• best bet B+ very good B good C+ fair C mediocre

only those records best suited for commercial use are reviewed by Cash Box

B+ REVIEWS

INTENTIONS (Uptown 710)

(B+) COOL SUMMER NIGHT (2:01) [Beechwood, BMI—Gibson, H. Bell, L. Bell, Ivey, Jackson] Blues rock-a-cha.

(B+) TIME (2:11) [Beechwood, BMI—Gibson, H. Bell, L. Bell, Ivey, Jackson] Same here.

BEVERLY McMURRAY (Associated Artists 1264)

(B+) THE IMAGE (2:37) [Lou-Keith, BMI—Hodges] Potent vocal on this buesy ballad.

(B) TAKING MY BABY'S LOVE (2:34) [Lou-Keith, BMI—Douglas, Hodges] Lilted side.

BENNIE THOMAS (RCA Victor 8648)

(B+) HERE COMES MY BABY (2:25) [Tree, BMI—D. West, B. West] Cover of the recent Dottie West c&w hit.

(B) YOUNG AND LONELY (2:14) [Helios, BMI—Raleigh, Barkan] Easy moving shuffler.

JOEL JOHNSON (Hall-Way 1209)

(B+) WAIT AND SEE (1:52) [Big Bopper, BMI—Johnson] Interesting mid-tempo ballad.

(B) IF I HAD A HAMMER (2:24) [Ludlow, BMI—Hays, Seeger] Rock version of the folk standard.

SATISFACTIONS (Radiant 1515)

(B+) (I GET LOTS OF) SATISFACTIONS (3:30) [Immediate, BMI—Jagger, Richard] Late cover sound of the Rolling Stones side.

(B) THE ANGRY DESERT (2:27) [Pattern, BMI—Howard] Strange instrumental-choral lid.

CHEATERS (Wax 210)

(B+) GIRL I WANT (2:04) [Delta R&E, Goetzl, Landau] Wild driving stomp number.

(B) TAKE IT EASY (2:01) [Merrie - Making, Centner] Cricket-styled rocker.

JODY DANIEL (N-Joy 1011)

(B+) THE THE GO, GO (1:52) [Rocrob, Daniel] Multi-dance rhythmic outing.

(B) QUANDO CALENTIA EL SOL (2:07) "Love Me With All Your Heart" in an ork cushioned setting.

JOHN LEE HOOKER (Vee-Jay 670)

(B+) BIG LEGS, TIGHT SKIRT [Conrad, BMI—Hooker] Blues sound with a solid beat.

(B) YOUR BABY AIN'T SWEET LIKE MINE [Conrad, BMI—Hooker] Steady rockin' city blues.

FOUR FRESHMEN (Capitol 5471)

(B+) OLD CAPE COD (2:38) [George Pincus & Sons, ASCAP—Rothrock, Yakus, Jeffrey] Beautiful coin-op item on this softie.

(B) THOSE MAGNIFICENT MEN IN THEIR FLYING MACHINES (1:58) [Miller, ASCAP—Goodwin] Rollicking rock romp through the movie theme.

ROCKIN' RAMRODS (Southern Sound 205)

(B+) WILD ABOUT YOU (2:02) [Chicory, BMI—Hunter, Boulanger] Infectious up-tempo driver.

(B) CRY IN MY ROOM (2:40) [Claridge, ASCAP—Campisi] Downhearted rock lament.

ROY ETZEL (MGM K13381)

(B+) THE SILENCE (3:02) [Embassy, BMI—Celeste, Brezza] Beautiful trumpet-chorale side.

(B) MELANCHOLY (2:58) [Canta Gallo Int'l, BMI—Fuchsberger] Lovely lilter.

TWILIGHTS (Parrot 45013)

(B+) TAKE WHAT I GOT (2:04) [Tree, BMI—Tex] Rollicking middle tempo rocker.

(B+) SHE'S THERE (2:11) [Bodean, BMI—Moss] Potently orked blues bouncer.

YOUNGFOLK (United Artists 906)

(B+) MR. TAMBOURINE (2:05) [Circle Seven, Unart, BMI—Perkins, Bradshaw] Driving rock side.

(B) THAT LOLLYPOP FEELING (2:12) [H.W.S., United Artists, ASCAP—Hooven, Winn] Happy-go-lucky rollicker.

PROFILES (Gait 1444)

(B+) NEVER (2:36) [Gaitwood, David, BMI—Watson] Driving pop-r&b mover.

(B) RIGHT BY HER SIDE (2:28) [Gaitwood, David, BMI—Divila, Martinez] Way back ballad.

DON & THE GOODTIMES (Dunhill 4008)

(B+) LITTLE SALLY TEASE (2:40) [Burdette, BMI—Valley] Hard moving deck.

(B) LITTLE GREEN THING (1:40) [Burdette, BMI—Lewis] Funky organ showcasing blueser.

LIZ BRADY (Capitol 5479)

(B+) HEY O DADDY O (2:17) [Acuff-Rose, BMI—Turnbow, Finnicum, Parks, Bernet] Up-tempo French tune.

(B) COMME TU ES JEUNE (3:18) [B.I.E.M., Perf. Rts. Free—Gerard, Bernet] Pretty, throaty ballad.

H. B. BARNUM (Capitol 5477)

(B+) I CAN'T HELP IT (2:35) [Fred Rose, BMI—Williams] Lovely pop waxing of the Hank Williams hit.

(B) DANCE WITH ME (2:26) [Gulla, BMI—Buchanan, Hollins] Easy moving lilter.

BRITAIN BROTHERS (TCF-Hall 108)

(B+) 300 DAYS (2:28) [Dixianna, BMI—Wilson, Moore] Lively side.

(B) MARY-GO-ROUND (2:21) [Dixianna, BMI—Wilson, Moore] Teen cha-cha ballad.

B+ REVIEWS

ARTHUR GODFREY (Admiral 765)

(B+) DIG, DIG, DIG (2:11) [Lorne Greene, BMI—C. Spencer, H. Spencer, Galla] Bouncy revival of the c&w hit.

(B) I'D GIVE A MILLION TOMORROWS (2:21) [Oxford, ASCAP—Berle, Livingston] Light reading of the oldie.

COMPLIMENTS (Congress 243)

(B+) YOU ARE MY SUNSHINE (2:35) [Peer Intl, BMI—Mitchell] Bouncy blues revamping of the sturdie.

(B) SHAKE IT UP, SHAKE IT DOWN (2:21) [Ashland, BMI—Ferrigno, Bonnadonna, Prano] Moving side.

THE STONE HENRY SINGERS (Kapp 693)

(B+) THAT WONDERFUL FEELING OF LOVE (2:20) [Camelback Mountain ASCAP—Kelly, Cox, Ballard] Wailing ballad, nicely handled by the chorus.

(B) YOU KILLED THE THRILL IN MY HEART (2:10) [Camelback Mountain ASCAP—Kelly, Ballard] Funky blues material on this lid.

SEDATIOUS BROWN (Roulette 4636)

(B+) WE AIN'T GONNA MAKE IT (2:20) [Ferneliff BMI—Bowie, Miles] Artist comes across with a well-orked item for the r&b fans.

(B) WHERE THERE'S A WILL THERE'S A WAY (3:17) [Ferneliff BMI—Bowie] Pretty, philosophical stanza here.

MIKI DALLON (RCA Victor 8649)

(B+) I CARE ABOUT YOU (2:41) [Millwick BMI—Dallon] Real soft orking on a screaming blueser.

(B) I'LL GIVE YOU LOVE (2:16) [Millwick BMI—Segal] Barrelling, pounder for the dance set.

DONDI (Challenge 1243)

(B+) BUZZ, BUZZ, BUZZ (2:05) [Cash BMI—Byrd, Gray] Lots of dance potential on this driver.

(B) S & L (2:59) [Zulu, 4 Star Sales BMI—Henderson, Benay] Switch to a percolatin' instrumental on the flip.

GERALD WILSON ORCHESTRA (World-Pacific 434)

(B+) IN THE LIMELIGHT (2:16) [Amestoy BMI—Wilson] Groovy jazz piece culled from the artist's LP, "On Stage."

(B) COULD BE (2:22) [Jana BMI—McCann] Satin-soft jazz blueser, good for late night programming.

ROUND ROBIN (Domain 1009)

(B+) I'M THE WOLF MAN (2:35) [4 Star Sales BMI—Baker, Knight] Crashing teen item with heaps of danceability.

(B) SIT AND DANCE (2:10) [Popcorn BMI—Romans, Fink] Lots more dance material with this fruggin' instrumental.

RUTH McFADDEN (Sure-Shot 5011)

(B+) DO IT UP RIGHT (2:13) [Don BMI—Fann, Roberts, Mosley] Lark does a nice job with a snapping jerker.

(B) I'LL CRY (2:28) [E. B. Marks BMI—McCoy, Steward] Change of pace to soulful blues styling.

SYL JOHNSON (TMP-Ting 115)

(B+) I'VE GOT TO GET OVER (2:22) [Toddmark BMI—Scott] Melancholy wooser with catchy backing.

(B) FALLING IN LOVE AGAIN (2:25) [Toddmark BMI—Goldberg] Slightly more up-tempo on this finger-snapper.

BOB & BOBBY (Tower 154)

(B+) TWELVE-O-FOUR (2:55) [New Executive, BMI—Norberg] Mid-tempo multi-dance duet.

(B) BABY WHAT YOU WANT ME TO DO (2:12) [Conrad, BMI—Reed] Big beat revival of the Jimmy Reed oldie.

STAN KENTON (Capitol 5480)

(B+) THEME FROM PEYTON PLACE (2:09) [Robbins ASCAP-Waxman] Vet orkster dishes up his usual fine stuff. Just right for smooth programming.

(B+) 007 (2:30) [Anton ASCAP-Kenton] Thrills and chills in the secret agent vein.

THE DENIMS (Columbia 43367)

(B+) EVERYBODY LET'S DANCE (2:02) [Fame BMI—Hall] Hard, bashing teen sound for the 'monkey' lovers.

(B) SAD GIRL (2:14) [Screen Gems-Columbia BMI—Curry, John, Duff, Zaccor, Arnell, Super] Forlorn, sentimental ballad.

SUSAN KING (Turntable 711)

(B+) DRUM RHYTHM (2:18) [Sentimental BMI—King, Gibbs, Lucie] Spirited, teen-slanted mover.

(B) YOU GOT ME IN A FIX (2:14) [Playnote BMI—Wright, Lucie] Smooth job on a jerkin' lament.

THE VAGRANTS (Southern Sound 204)

(B+) OH THOSE EYES (2:34) [Claridge ASCAP-Storch] A real pretty ballad gets the 'Mersey' treatment.

(B) YOU'RE TOO YOUNG (2:00) [Claridge ASCAP-Tyson, Abrahams] This side is the same, but slightly more uptempoed.

SOUL INC (Joli 075)

(B+) IT REALLY DOESN'T MATTER NOW (2:10) [Bingo BMI-Sullivan] Harsh vocal backed by a pounding combo.

(B) YOU BETTER GET A MOVE ON (2:10) [Bingo BMI-Sullivan] Wailing multi-danceable.

HOMER & JETHRO

These wild and wacky musicians (!) are at it again in "Homer & Jethro Sing Tenderly" (LPM/LSC 3357). It's an album that's loaded with laughs—H. & J. do their most with ballads like "Fly Me to the Moon" and "Arrivederci, Roma." Give this one feature promotion and watch it take off!

RCA Victor
The most trusted name in sound

HOMER & JETHRO
sing
TENDERLY
and
**OTHER GREAT
LOVE BALLADS**





LOOKING AHEAD

A compilation, in order of strength, of up and coming records showing signs of breaking into the Cash Box Top 100. List is compiled from retail outlets.

- | | | | |
|---|--|---|--|
| <p>1 YOU'VE BEEN IN LOVE TOO LONG
(Jobete—BMI)
Martha and the Vandellas (Gordy 7045)</p> <p>2 HEARTACHES BY THE NUMBERS
(Pamper—BMI)
Johnny Tillotson (MGM 13376)</p> <p>3 LIAR LIAR
(Celann—BMI)
Castaways (Soma 1433)</p> <p>4 THE LOSER
(Wemar—BMI)
Skyliners (Jubilee 5506)</p> <p>5 I'LL TAKE YOU WHERE THE MUSIC IS
(Trio—BMI)
Drifters (Atlantic 2298)</p> <p>6 TRUCK DRIVIN' SON OF A GUN
(Raleigh—BMI)
Dave Dudley (Mercury 72442)</p> <p>7 TOO HOT TO HOLD
(Dakar—BMI)
Major Lance (Okeh 7726)</p> <p>8 WE'RE DOING FINE
(Leatherneck-Wellmade—BMI)
Dee Dee Warwick (Blue Rock 4027)</p> <p>9 IF YOU WAIT FOR LOVE
(Unart—BMI)
Bobby Goldsboro (United Artists 908)</p> <p>10 THE TRACKER
(Crazy Cajun—BMI)
Sir Douglas Quintet (Tribe 8310)</p> <p>11 I LEFT MY HEART IN SAN FRANCISCO
(General—ASCAP)
Fats Domino (Mercury 72463)</p> <p>12 THE WORLD THROUGH A TEAR
(Bergman, Vocco & Conn.—ASCAP)
Neil Sedaka (RCA Victor 8637)</p> <p>13 YOUR BABY DOESN'T LOVE YOU ANYMORE
(High Wood—BMI)
Ruby & Romantics (Kapp 665)</p> | <p>14 I DON'T BELIEVE YOU
(Anihanbar—BMI)
Guilloteens (HBR 446)</p> <p>15 BOSS LOVE
(Mah's—BMI)
Lee Rogers (D-Town 1050)</p> <p>16 TWO DIFFERENT WORLDS
(Princess—ASCAP)
Lenny Welch (Kapp 689)</p> <p>17 LOVE ME NOW
(Benday, Motherneck—BMI)
Brook Benton (Mercury 72446)</p> <p>18 MOHAIR SAM
(Acclaim—BMI)
Charlie Rich (Smash 1993)</p> <p>19 THAT GOES TO SHOW YOU
(Flomar-Baby Monica—BMI)
Garnet Mimms (United Artists 887)</p> <p>20 GOOD TIMES
(Chi-Sound-Jalynne—BMI)
Gene Chandler (Constellation 160)</p> <p>21 LOUIE LOUIE
(Limax—BMI)
Kingsmen (Wand 143)</p> <p>22 FOR YOUR LOVE
(Beachwood—BMI)
Sam and Bill (Joda 100)</p> <p>23 I NEED YOU
(Chi-Sound—BMI)
Impressions (ABC 10710)</p> <p>24 99 + 1
(Bonatemp, Rated—BMI)
J. Gardner (Blue Rock 4026)</p> <p>25 FIRST, I LOOK AT THE PURSE
(Jobete—BMI)
Contours (Gordy 7044)</p> <p>26 IF I HAD MY LIFE TO LIVE OVER
(General—ASCAP)
Lloyd Price (Monument 887)</p> | <p>27 THESE HANDS (SMALL BUT MIGHTY)
(Don—BMI)
Bobby Bland (Duke 385)</p> <p>28 LAUGH AT ME
(Five-West, Cotillion—BMI)
Sonny (Atco 6369)</p> <p>29 YOU CAN'T BE TRUE DEAR
(Bilmore—ASCAP)
Patti Page (Columbia 43345)</p> <p>30 SOUTHERN COUNTRY BOY
(Dublin—BMI)
Carter Bros. (Jewel 745)</p> <p>31 THE TURNAROUND
(Blue Horizon—BMI)
Hank Mobley (Blue Note 1915)</p> <p>32 MOONGLOW (THEME FROM PICNIC)
(Mills—ASCAP)
Esther Phillips (Atlantic 8203)</p> <p>33 STORM WARNING
(Stil-Ran-Dandelion Music)
The Volcanos (Arctic 106)</p> <p>34 I WANT TO (DO EVERYTHING FOR YOU)
(Tree—BMI)
Joe Tex (Dial 4016)</p> <p>35 PEOPLE SAY
(Morglo—BMI)
John and Paul (Tip Top 1021)</p> <p>36 LET'S HAVE A BEACH PARTY
(RSVP & Kev-Ton—BMI)
Pleasures (RSVP 1113)</p> <p>37 LITTLE MISS SAD
The Five Impressions (Freeport 1001)</p> | <p>38 JOYRIDE
(Bright Tunes—BMI)
Randy & Rainbows (Rust 5101)</p> <p>39 DO THE 45
(Jobett—BMI)
Sharpies (One-Derful 4835)</p> <p>40 MY SHIP IS COMIN' IN
(January—BMI)
Jimmy Radcliffe (Aurora 154)</p> <p>41 GREAT -GOO-GA-MOO-GA
(Chi-Sound & Payton—BMI)
Tom and Jerrio (ABC-Paramount 10704)</p> <p>42 CAN'T GET YOU OUT OF MY SIGHT
(Screen Gems Columbia—BMI)
Chuck Jackson and Maxine Brown (Wand 191)</p> <p>43 THE WAY OF LOVE
(Chappell—ASCAP)
Kathy Kirby (Parrot 9775)</p> <p>44 YOU'VE GOT YOUR TROUBLES
(Mills—ASCAP)
Fortunes (Press 9973)</p> <p>45 WHOLE LOTTA WOMAN
(Chevis—BMI)
Radiants (Chess 1939)</p> <p>46 WHITTIER BLVD.
(Conte BMI)
Thee Midnighers (Chattahoochee 684)</p> <p>47 DO YOU BELIEVE IN MAGIC
(Faithful Virtue—BMI)
Lovin' Spoonful (Kama Sutra 201)</p> <p>48 WHERE DOES LOVE GO
(Radford—BMI)
Charles Boyer (Valiant 719)</p> <p>49 TIGER WOMAN
(Al Gallico BMI)
Claude King (Columbia 43298)</p> <p>50 I DON'T WANT TO LIVE (WITHOUT YOUR LOVE)
(Leeds—ASCAP)
Bobbi Martin (Coral 62457)</p> |
|---|--|---|--|

BARRY YOUNG

"ONE HAS MY NAME"

b/w

"SHOW ME THE WAY"

SHINDIG
LLOYD THAXTON SHOW
HOLLYWOOD A-GO-GO
AMERICAN BANDSTAND
9TH STREET WEST
SHIVAREE
WHERE THE ACTION IS
SHEBANG



PERSONAL MANAGER
ROBERT P. MARCUCCI

THANK YOU . . .

EVERYBODY!

Wayne Newton



CURRENT SINGLE:

"SUMMER WIND"

Capitol 5470

FORTHCOMING ALBUM

"SUMMER WIND"

PRODUCED BY:



MUSIC INC.

NEW YORK-LOS ANGELES

released by:



RCA "VICTROLA" PRESENTS FOUR WAYS TO BRIGHTEN YOUR PROFIT PICTURE

Here are four more sales-boosting albums from "Victrola." Stock up now, to meet your customers' requests.



1.



3.



2.



4.

1. **BEETHOVEN: Symphony No. 4/WAGNER: Siegfried Idyll**, Pierre Monteux, the London Symphony and the San Francisco Symphony Orchestras. This new addition to the "Victrola" catalog is sure to be greatly sought after by Monteux's enormous following. VIC/VICS-1102
2. **BACH: Violin Concerto No. 1/MOZART: Violin Concerto No. 3**, Jaime Laredo, the Boston Symphony under Munch, the National Symphony under Mitchell. Two great violin concertos superbly played by the distinguished Bolivian-born violinist. VIC/VICS-1129
3. **DELIBES: Sylvia and Coppélia Ballet Suites**, Paris Conservatory Orchestra, Hugo Rignold. Classical ballet music at its most appealing. Very pleasant listening, especially as played by Rignold and the Paris Conservatory Orchestra. VIC/VICS-1130
4. **Overtures and Intermezzos from Famous Operas**, Royal Opera House Orchestra, Covent Garden, Georg Solti. The sort of album opera lovers delight in. Well-loved melodies beautifully performed by one of the world's finest opera house orchestras. VIC/VICS-1119

RCA **VICTROLA**®



TOP 100 Albums

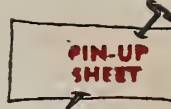

AUGUST 14, 1965

Pos.	Last Week	Album	Pos.	Last Week	Album	Pos.	Last Week	Album	Pos.	Last Week	Album
1		BEATLES VI (Capitol T/ST 2358)	1		MEANWHILE BACK AT THE WHISKY 'A GO GO Johnny Rivers (Imperial LP 9284/LP 12284)	51		HAVING A WILD WEEKEND 96 Dave Clark Five (Epic LN 24162/BN 26162)	76		RAMBLIN' ROSE 58 Nat King Cole (Capitol T/ST 1793)
2		HERMAN'S HERMITS ON TOUR (MGM E/SE 4295)	2		FIDDLER ON THE ROOF 23 Original Cast (RCA Victor LCO/LSO 1093)	52		PEOPLE 43 Barbra Streisand (Columbia CL 2215/CS 9015)	77		DO I HEAR A WALTZ? 62 Original Cast (Columbia KOL 6370/KOS 2770)
3		MARY POPPINS Soundtrack (Buena Vista BV 4026/4026)	3		WOOLY BULLY 26 Sam The Sham And The Pharaohs (MGM E/SE 4297)	53		THE LOVE ALBUM 46 Trini Lopez (Reprise R/RS 6165)	78		BEATLES '65 64 (Capitol T/ST 2228)
4		SUMMER DAYS AND SUMMER NIGHTS Beach Boys (Capitol T/ST 2354)	5		WHAT'S NEW PUSSYCAT? 40 Soundtrack (United Artists UAL 4128/UAS 5128)	54		YOU TURN ME ON 51 Ian Whitcomb (Tower T 5004)	79		LOVE AFFAIR — Ray Conniff & Singers (Columbia CL 2352/CS 9152)
5		SOUND OF MUSIC Soundtrack (RCA Victor LOCD/LSOD 2005)	4		KING FAMILY SHOW 33 (Warner Bros. W/WS 1601)	55		CHIM CHIM CHEREE 50 New Christy Minstrels (Columbia CL 2369/CS 9169)	80		AN HISTORIC RETURN HOROWITZ AT CARNEGIE HALL 66 Vladimir Horowitz (Columbia M2L 328/M2S 728)
6		MY NAME IS BARBRA Barbra Streisand (Columbia CL 2336/CS 9136)	6		THE LATIN SOUND OF HENRY MANCINI 36 (RCA Victor LPM/LSP 3356)	56		EARLY MORNING RAIN 48 Ian & Sylvia (Vanguard VRS 9175/VSD 79175)	81		MONSTER 70 Jimmy Smith (Verve V/V6 8616)
7	11	OUT OF OUR HEADS Rolling Stones (London LL 3429/PS 429)	11		INTRODUCING HERMAN'S HERMITS 24 (MGM E/SE 4282)	57		BABY THE RAIN MUST FALL 53 Glenn Yarbrough (RCA Victor LPM/LSP 3422)	82		BLOCKBUSTERS 84 Jay & Americans (United Artists UAL 3417/UAS 6417)
8	7	MR. TAMBOURINE MAN Byrds (Columbia CL 2372/CS 9172)	7		WHERE DID OUR LOVE GO 27 Supremes (Motown MT 621/S 621)	58		SOUL SAUCE 60 Cal Tjader (Verve V/V6 8614)	83		LOUIE LOUIE 87 Kingsmen (Wand LP/S 657)
9	8	BRINGING IT ALL BACK HOME Bob Dylan (Columbia CL 2328/CS 9128)	8		THE ROAR OF THE GREASEPAINT—THE SMELL OF THE CROWD 28 Original Cast (RCA Victor LOC/LSO 1109)	59		FOR YOUR LOVE 69 Yardbirds (Epic LN 24167/BN 26167)	84		MR. STICK MAN 86 Pete Fountain (Coral CRL 57473/CRL 757473)
10	10	THE BEACH BOYS TODAY! (Capitol T/ST 2269)	10		CAST YOUR FATE TO THE WIND 32 Sounds Orchestral (Cameo P/PS 7046)	60		MY KIND OF TOWN 54 Jack Jones (Kapp KL 1433/KS 3433)	85		SOMEBODY ELSE IS TAKING MY PLACE 83 Al Martino (Capitol T/ST 2312)
11	9	DEAR HEART Andy Williams (Columbia CL 2338/CS 9138)	9		THREE O'CLOCK IN THE MORNING 42 Bert Kaempfert (Decca DL 4670/DL 74670)	61		THE NEW SEEKERS 57 (Capitol T/ST 2319)	86		RED ROSES FOR A BLUE LADY 71 Wayne Newton (Capitol T/ST 2335)
12	14	MY FAIR LADY Soundtrack (Columbia KOL 8000/KOS 2600)	14		IT'S NOT UNUSUAL 39 Tom Jones (Parrott PA 61004, PAS 71004)	62		I DO LOVE YOU 61 Billy Stewart (Chess 1496)	87		BOBBY VINTON SINGS FOR LONELY NIGHTS 88 (Epic LN 24154/BN 26154)
13	12	ROLLING STONES NOW! (London LL 3420/PS 420)	12		THIS IS NEW 49 Righteous Bros. (Moonglow 1003)	63		GREATEST HITS FROM THE BEGINNING 56 The Miracles (Motown MT/S 254)	88		GERRY AND THE PACEMAKERS GREATEST HITS 80 (Laurie LLP/SLP 2031)
14	13	THE GENIUS OF JANKOWSKI Horst Jankowski (Mercury MG 20993/SR 60993)	13		THE IN CROWD 94 Ramsey Lewis (Argo LP 157/S 157)	64		RAY CONNIFF PLAYS MARY POPPINS 59 (Columbia CL 2366/CS 9166)	89		HALF A SIXPENCE 81 Original Cast (RCA Victor LOC/LSO 1110)
15	16	JUST ONCE IN MY LIFE The Righteous Bros. (Philly LP/S 4008)	16		THE RETURN OF ROGER MILLER 31 (Smash MGS 27061/SRS 67061)	65		KINKS SIZE 65 (Reprise R/RS 6158)	90		SEPTEMBER OF MY YEARS — Frank Sinatra (Reprise F/F5 1014)
16	17	SINATRA '65 Frank Sinatra (Reprise R/RS 6167)	17		INTRODUCING THE BEAU BRUMMELS 34 (Autumn LP/ST 103)	66		BEACH BOYS IN CONCERT 68 (Capitol TAO/STAO 2198)	91		AN EVENING WITH BELAFONTE/MAKEBA 90 Harry Belafonte & Miriam Makeba (RCA Victor LPM/LSP 3420)
17	15	WHIPPED CREAM AND OTHER DELIGHTS (Tijuana Brass (A & M LP/SP 110)	15		THE NEARNESS OF YOU 55 John Gary (RCA Victor LPM/LSP 3349)	67		BLUE MIDNIGHT 63 Bert Kaempfert (Decca DL 4569/DL 74569)	92		ELGART A GO GO 98 Les & Larry Elgart (Columbia CL 2355/CS 9155)
18	29	THIRD TIME AROUND Roger Miller (Smash MGS 27068/SRS 67068)	29		FOUR TOPS 47 (Motown M/S 622)	68		SUMMER SOUNDS 79 Robert Goulet (Columbia CL 2380/CS 9180)	93		GENTLE IS MY LOVE — Nancy Wilson (Capitol T/ST 2351)
19	18	GIRL HAPPY Elvis Presley (RCA Victor LPM/LSP 3338)	18		THE BEST OF AL HIRT 37 (RCA Victor LPM/LSP 3309)	69		CANADIAN SUNSET 72 Andy Williams (Columbia CL 2324/CS 9124)	94		YELLOW ROLLS ROYCE 97 Soundtrack (MGM E/SE 4202)
20	19	TODAY MY WAY Nancy Wilson (Capitol T/ST 2321)	19		AL HIRT, LIVE AT CARNEGIE HALL 52 (RCA Victor LPM/LSP 3416)	70		THE GOLDEN HITS OF LESLEY GORE 73 (Mercury MG 21024/SR 61024)	95		HERE THEY COME 100 Paul Revere & Raiders (Columbia CL 2307/CS 9107)
21	20	MARIANNE FAITHFULL (London LL 3423/PS 423)	20		THE SCENE CHANGES 41 Perry Como (RCA Victor LPM/LSP 3396)	71		TRUE LOVE WAYS 76 Peter & Gordon (Capitol T/ST 2368)	96		THE TEMPTATIONS SING SMOKEY 91 (Gordy G/S 912)
22	22	THE VENTURES ON STAGE (Dolton BLP 2035/BST 8035)	22		HUSH, HUSH, SWEET CHARLOTTE 38 Patti Page (Columbia CL 2353/CS 9153)	72		ONE KISS FOR OLD TIMES SAKE 78 Ronnie Dove (Diamond S/SD 9160)	97		CAT BALLOU 97 Nat Cole (Capitol T/ST 2340)
23	25	A SONG WILL RISE Peter, Paul and Mary (Warner Bros. W/WS 1589)	25		ZORBA THE GREEK 44 Soundtrack (20th Fox TFM 3167/TFS 467)	73		CATCH THE WIND 75 Donovan (Hickory LPM 123)	98		YOU WERE ONLY FOOLING 99 Vic Damone (Warner Bros. W/WS 1602)
24	21	GOLDFINGER Soundtrack (United Artists UAL 4117/UAS 5117)	21		SONGS FOR THE JET SET 45 Tony Bennett (Columbia CL 2343/CS 9143)	74		EDDIE FISHER TODAY 77 (Dot DLP 3631/DLP 25631)	99		I KNOW A PLACE 92 Petula Clark (Warner Bros. W/WS 1598)
25	35	BEFORE AND AFTER Chad & Jeremy (Columbia CL 2374/CS 9174)	35		THEM 67 (Parrott PA 61005/PAS 71005)	75		JR. WALKER & THE ALL STARS PLAY SHOTGUN 74 (Soul 1701)	100		HOW TO BE A JEWISH MOTHER — Gertrude Berg (Amy 8007)

LOOKING AHEAD ALBUMS

1	MORE HITS BY THE SUPREMES (Motown 627/S 627)	7	JAMES BOND THRILLERS Robert Shaw Orch. (London LL 3412/PS 412)	13	KISMET Lincoln Center Original Cast (RCA Victor LOC/LSO 1112)	19	LOVE AT HOME King Family (Capitol T/DT 2352)
2	SOUL SERENADE Gloria Lynne (Fontana MGF 27541/SRF 67541)	8	THE TURNAROUND Hank Mobley (Blue Note 4186)	14	BEST OF HUGO WINTERHALTER (RCA Victor LPM/LSP 3379)	20	MISS MORGANA KING Mainstream (M 56052/S 6052)
3	THOSE MAGNIFICENT MEN IN THEIR FLYING MACHINES Soundtrack (20th Century Fox TFM 3147/TFS 4147)	9	HOW TO STUFF A WILD BIKINI Kingsmen (Wand LP/S 671)	15	TONY'S GREATEST HITS VOL. III Tony Bennett (Columbia CL 2373/CS 9173)	21	THE ART OF LOVE Cy Coleman (Capitol T/ST 2355)
4	SONG FOR MY FATHER Horace Silver (Blue Note 4185)	10	ENGLAND'S GREATEST HITMAKERS Various Artists (London LL 3430/PS 430)	16	FEELS LIKE LOVIN' Stu Phillips (Capitol T/ST 2356)	22	MUSIC FROM SHIP OF FOOLS Arthur Feidler (RCA Victor LM/LSC 2817)
5	I LOVE YOU SO Bobbi Martin (Coral CRL 57478/CRL 75748)	11	HIS HAND IN MINE Elvis Presley (RCA Victor LPM/LSP 2328)	17	IF I LOVED YOU Johnny Mann Singers (Liberty LRP 3411/LST 7411)	23	FOR YOU FROM US Astronauts (RCA Victor LPM/LSP 3359)
6	DOUBLE HEADER Arthur Prysock (Old Town LP 2009)	12	STRANGERS & COUSINS Pete Seeger (Columbia CL 2334/CS 9134)	18	ANGEL EYES Dave Brubeck Quartet (Columbia CL 2348/CS 9148)	24	LOVE IS EVERYTHING Johnny Mathis (Mercury MG 20991/SR 60991)

POP PICKS

ELVIS FOR EVERYONE—Elvis Presley—RCA Victor LPM/LSP 3450

Sitting pretty in the top twenty with "Girl Happy," and already boasting fifteen LP's that have passed the \$1,000,000 sales mark, Elvis Presley has come up with another sure-fire item that should pull in enough attention to rocket up the LP charts. The world famous swinger puts together a gathering of up-tempo and soft sounds, highlighted by "I Met Her Today" and "Summer Kisses, Winter Tears." Hauling in singles exposure with 2 top 100 items, the songwriter's hitsville path is paved.

GENTLE IS MY LOVE—Nancy Wilson—Capitol T/ST 2351

Currently holding down a top twenty spot with her last LP, Nancy Wilson is sure to grab loads of attention with her new sampling, "Gentle Is My Love." The romantic setting brilliantly sets a silken mood that is aptly suited to her velvet vocal talent, and her exquisite reading of songs like "If Ever I Would Leave You," "There Will Never Be Another You" and the title track make it a package likely to be added to many programming schedules on pop outlets. Overwhelmingly beautiful.

I'M THE ONE WHO LOVES YOU—Dean Martin—Reprise R/RS 6170

Clicking with sales on both the pop and teen fronts, Dean Martin has cultivated a following that makes each of his efforts one that is a sure bet to reach the best seller charts. This new LP is no exception, packing all the smoothness and sophistication that has endeared the chanter to millions. Among the enchanting selections to be found here are his latest hit ("Remember Me) I'm the One Who Loves You" with other recent "King of the Road" and "Birds And The Bees."

LOOKING BACK—Nat "King" Cole—Capitol T/ST 2361

A phenomenal seller for over a decade, the late Nat Cole is shown in all his brilliance on this collection of softies in his own inimitable style. The chanter's satin voice is showcased with eleven ballads against a lush orchestral and soft choral backdrop. Among the outstanding selections included on this set are "Time and the River," "Sweet Bird of Youth" and "Just as Much as Ever." Sure to be a strong catalog item, the LP should follow the hit footsteps of his last "L-O-V-E" outing.

UP THROUGH THE YEARS—Jim Reeves—RCA Victor LPM/LSP 3427 (e)

An artist whose sales have not dwindled even now, a year after his death, Jim Reeves' popularity on the pop scene as well as in the c&w field should turn this offering into a hit LP. Spot-lighting a dozen of the chanter's best known tunes, it showcases his talents in a most appealing set. Highlight tracks include "Bimbo," his "Nooitjé Van Die Ou Transvaal" and "Two Shadows on Your Window." Chart spot is almost certain for this LP.

HOW TO STUFF A WILD BIKINI—Orig. Soundtrack—Wand 671

The fifth in producers' Nicholson and Arhoff's series of "Beach Party" films has more to recommend it than a teen-star-studded cast; it features a score that could turn up a best selling album for Wand Records. Spot-lighting the talents of the Kingsmen and Annette among others, the set should see a sizeable sales showing. Among the tunes that show up nicely on this recording are: "Give Her Lovin'," "Better Be Ready" and the title track, "How to Stuff a Wild Bikini."

JOHNNY CASH SINGS THE BALLADS OF THE TRUE WEST—Columbia C2L 38/C2S 838

An artist whose fan clubs range from the country to the pop to the folk idiom, Johnny Cash could very well score with all these areas via this package of musical stories of the old west. An impressive double record set, this album features the chanter narrating and singing some of the best known ballads to spring from the wild and wooly days in our country's history, including such epics as "The Shifting, Whispering Sands" and both sides of his current c&w chart single, "Mr. Garfield" and "The Streets Of Laredo."



14 ORIGINAL CHART TOPPERS—Various Artists UAL 3440/UAS 6440

Seven artists familiar to rock fans are represented by two hits apiece on this United Artists set which includes oldies, newies, English and blues. The all-star lineup features Jay and the Americans with their recent "Come A Little Bit Closer," Bobby Goldsboro's "Little Things" and Frankie Avalon singing "Dede Dinah." Manfred Mann, Danny Williams, Johnny Rivers and Garnet Mimms are also represented in a package that should see a considerable teen turnout.



MORE AMOR—Eydie Gorme and the Trio Los Panchos—Columbia CL 2376/CS 9176

The overwhelming success of the first teaming of Eydie Gorme and the Trio Los Panchos, "Amor," has precipitated another magnificent set of lovelies spiced with Latin fire. The blend of voices and guitars on this Columbia LP should find a large welcome with pop, good music and Spanish-speaking deejays, prompting perky sales responses both north and south of the border. Among the outstanding tunes beautifully handled are: "Flores Negras," "Mas Amor" and "Guitarra Romana."



ONLY THE BEST—Ferrante & Teicher—United Artists UAL 3434/UAS 6434

Excitingly lovely fare from the piano pairing of Ferrante and Teicher is nothing new, and as they prove again, the tunes may be selected from almost any musical area. Using three movie themes, an idiom that established their reputation, a handful of pop items, and several Broadway songs, the duo come up with some elegant spinning on this outing. Included on the platter are: "Red Roses For a Blue Lady," "Chim Cheree" and "Fiddler on the Roof." Should become an active LP.

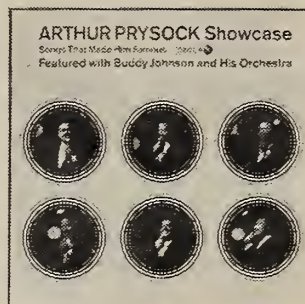

ARTHUR PRYSOCK SHOWCASE—Decca DL 4623/4623

A bright name among today's romantic vocalists, Arthur Prysock is featured on this album with many of the original recordings of the tunes that brought him to the successful position he now holds. Backed by Buddy Johnson and his orchestra, the chanter displays some of his range and versatility as he gently handles the tender, romantic love songs highlighted in the disk, including "We'd Only Start It All Over Again" and "Ever Since the One I Love's Been Gone."



MR. PHYLLIS—Joan Rivers—Warner Brothers W/WS 1610

A bright new comedienne who has been the center of much attention since her debut on the "Tonight" show in Feb., Joan Rivers is represented on nine tracks in a display of her sharp wit. The artist's first set is likely to find a large reception, with many of the stories brief enough for airplay to afford good exposure. Among the tales included here are: "Present for Mr. Phyllis," "The Drunk Dog" and "The Fat Girl." Chartbound.

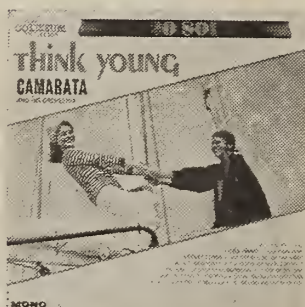

THINK YOUNG—Camerata—Coliseum D 41001/DS 51001

Vibrant musical interpretations of thirteen current and recent teen hits, by Camerata and Tutti's Trombones, comes across with a lively sophistication that should make for plenty of appeal to the "jet" and "Discotheque" sets. The London distributed LP features tunes like "(I Can't Get No) Satisfaction," "What's New Pussycat" and "Sunshine, Lollipops and Rainbows" for highly intriguing fare. Could find enough attention to break wide open.



BEAT & SOUL—Everly Brothers—Warner Brothers W/WS 1605

A pair that has already shown proficiency in many of the varied forms that rock has taken on the popular scene, the Everly Brothers turn on their full harmonic charm in this collection of the leading r&b hits of the past few months, with a number of blues standards thrown in for good measure. Among the outstanding spinners are: "People Get Ready," "Hi Heel Sneakers" and "The Girl Can't Help It." Plenty of programming and sales reactions are in store for this set.

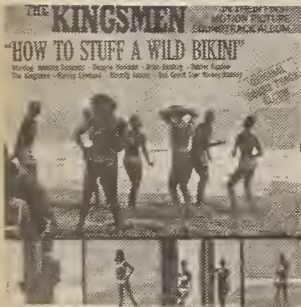
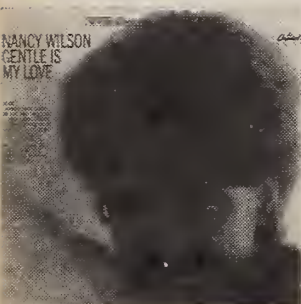

HELP! IS HERE

THE
SOUNDTRACK
ALBUM!

AIRPLAY BEGINS: AUGUST 9!
NATIONAL RELEASE: AUGUST 13!

NEW IMPROVED FULL DIMENSIONAL STEREO

ORIGINAL MOTION PICTURE SOUNDTRACK

THE
BEATLES



HELP!

HELP! · THE NIGHT BEFORE · YOU'VE GOT TO HIDE YOUR LOVE AWAY · I NEED YOU
ANOTHER GIRL · TICKET TO RIDE · YOU'RE GONNA LOSE THAT GIRL
And Exclusive Instrumental Music From the Picture's Soundtrack

SMAS-2386



FROM THE BEATLES!

NEW ALBUMS FOR AUGUST

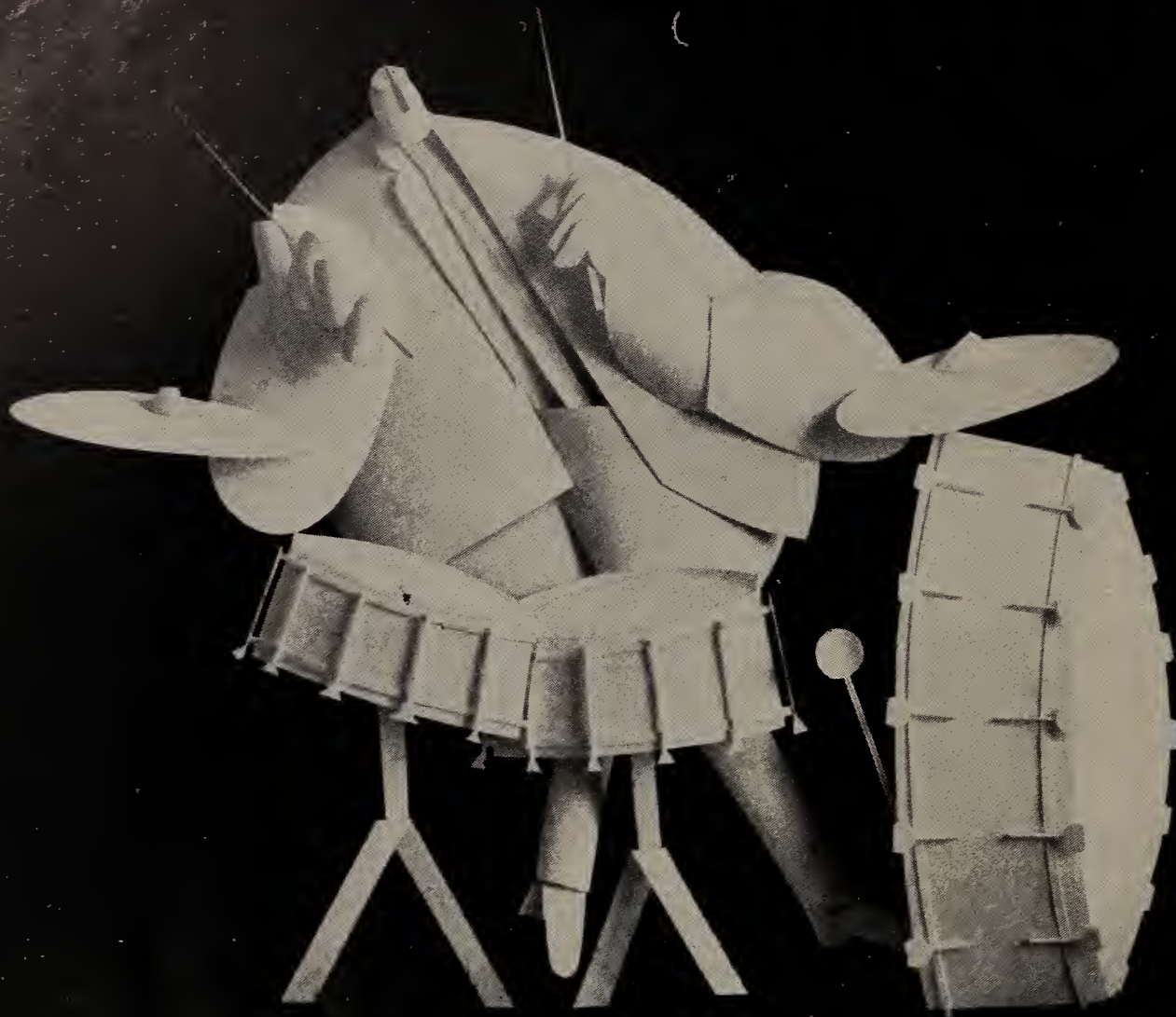

12 hits in his best selling style includes "Shindig," "Laughing Guitar," "The Restless Pack" and "Rebel Soul." In Dynagroove sound. LPM/LSP-3432



Official band of the World's Fair in 6 Broadway overtures. "The Sound of Music," "Fiddler On the Roof," more. In Dynagroove sound. LPM/LSP-3403



Big teen attraction. "Blue on Blue," "Not Every Day of the Week," "I Love You So Much It Hurts," 9 other hits. In Dynagroove sound. LPM/LSP-3408



A highly acclaimed and swinging new singer does "Misty," "Take Five," "The Song Is You," "Hello, Dolly!" 8 more. In Dynagroove sound. LPM/LSP-3397

OUTSTANDING NEW RED SEAL RECORDINGS



Signals a renaissance of interest in this exotic and fascinating music. Lewenthal's performances are great! In Dynagroove sound. LM/LSC-2815

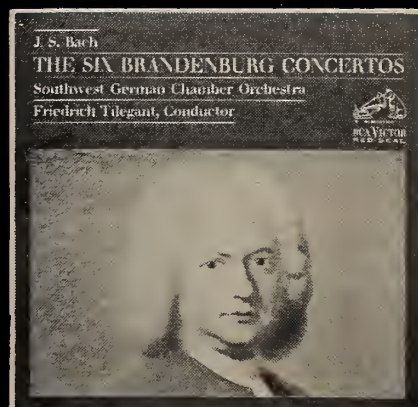



Distinguished artist-musicians presenting these Baroque treasures in the great European tradition. Six concertos on 2 L.P.s. LM/LSC-7038



A dynamic collaboration, the only recording of the two musicians together. Kapell's mastery contributes to the legend. LM-2831 (Mono only.)

ON RCA VICTOR

TMK/S B
 The most trusted name in sound 

EXCITING NEW POP ALBUMS



Top material by this hit country artist includes "Kentucky Waltz," "She Reads Me Like A Book," plus 10 more. In Dynagroove sound. LPM/LSP-3381



Floyd adds big band sound for big appeal in "Downtown," "Red Roses For A Blue Lady," "Mr. Lonely" and 9 more. In Dynagroove sound. LPM/LSP-3405



6 traditional native songs on 1 side and 6 modern songs on the other, recorded at Tahiti's top tourist spot, Quinn's Waterfront Bar. LPM/LSP-3344

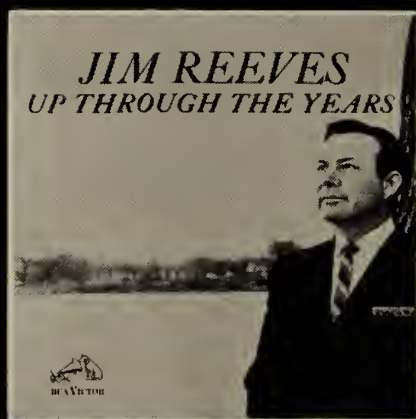

12 songs that trace Jim's career. "I Know One," "Bimbo," "Ichabod Crane," "Tweedle O' Twill," "Jimbo Jenkins," "I'm Hurtin' Inside." LPM/LSP-3427(e)



Great artists, great songs, great album. "Harbor Lights," "You're Breaking My Heart," "La Novia," 9 others. In Dynagroove sound. LPM/LSP-3413

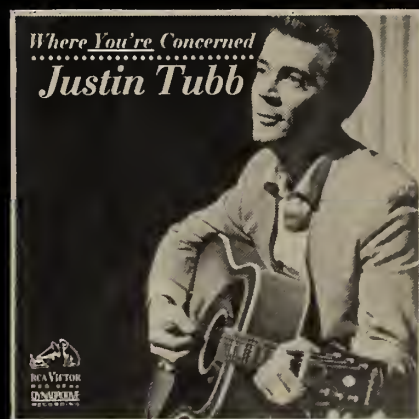

Carrying on the family name with his own hits. "Lonesome 7-7203," "Prematurely Blue," "If I Miss You," 9 more. In Dynagroove sound. LPM/LSP-3399



His many fans will welcome this addition to his recordings. Tenor Peter Pears joins him to sing six of Dowland's most charming lute songs. LM/LSC-2819



Rubinstein's ever-growing art glows in these warm, elegant performances. 2 L.P. set contains 8-page insert. In Dynagroove sound. LM/LSC-7037

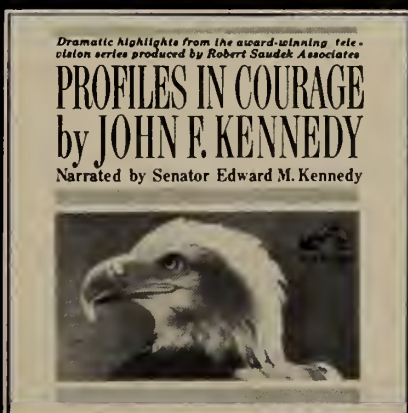

Finely acted performances of seven climactic moments from the widely hailed TV series. Sen. Edward Kennedy provides the narration. VDM-103



From the sell-out Carnegie Hall recital. Includes her great performance of the Mozart "Alleluia" and four Russian songs (in Russian). LM/LSC-2835



ONE MORE TIME WITH FEELING—Damita Jo—Epic LN 24164/BN 26164

Damita Jo really goes to town with this extremely varied collection of pop favorites, evergreens and a sprinkling of r&b oldies and newies, all handled in her distinctively emotion-packed blues style. Her rich, wide-ranged voice carries her in good stead on this package, one of the best disks she has cut in a long time. Some of the top offerings herein are "Ain't Nothing' Wrong With That" and "Gotta Travel On," as well as "Make Someone Love You."



MY KIND OF BROADWAY—Woody Herman—Columbia CL 2357/CS 9157

Hefty big band stylings and the best of the recent Broadway scores combine forces to turn up a set that has unlimited appeal. Woody Herman and his Swinging Herd's newest Columbia effort features tunes from hot mainstemmers like "Roar" ("Who Can I Turn To"), "The Sound of Music" ("My Favorite Things") and "The Boys From Syracuse" ("This Can't Be Love"). Moving in high style, the album captures all the liveliness and poignance of the songs in a sparkling showcase.

POP BEST BETS



SHENANDOAH—Original Soundtrack—Decca DL 9125/79125

The conflict and the poignancy of the new Universal Pictures release, "Shenandoah," has been powerfully complemented by a wonderful score composed by Frank Skinner. The film, starring James Stewart, Doug McClure and Rosemary Forsyth, deals with the problems faced by one family that tries to remain neutral during the Civil War, and the soundtrack is a strong musical interpretation of the film's drama. Top tracks include "Horse Play" and the Jimmy Stewart narration, "The Legend of Shenandoah."



THE BEST OF LIBERACE—Coral 7CXSB 9

The well-known piano stylings of Liberace have come to the fore once again in this delightfully pleasant two-record Coral LP. Backed by the orchestra under the baton of Gordon Robinson, the pianist dusts the keyboard in his interpretations of two dozen of the biggest tunes of the last few decades, including twinkling versions of "Love Is A Many Splendored Thing" and "Me And My Shadow," as well as a lively run with "Mack The Knife."



SENTIMENTAL JOURNEY—Doris Day—Columbia CL 2360/CS 9160

The perennially young and sparkling voice of Doris Day is stunningly highlighted on this lush, romantic "Sentimental Journey" LP which showcases the songstress before arrangements by Mort Garson. A dozen sturdies, particularly soft ballads, provide the fare, with tunes like: "The More I See You," "I'm Beginning to See the Light" and "It's Been a Long, Long Time." Long a programmer's favorite, the lark's latest outing should be one that will see active sales action.

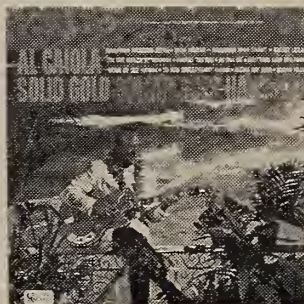

SOLID GOLD GUITAR GOES HAWAIIAN—Al Caiola—United Artists UAL

The money-making guitar of Al Caiola, which has chalked up many a hit with melodies from the Mainland, has turned its attention to the tropical shores of the Hawaiian Isles and delivered another easy-to-listen-to performance. Conducted by Nick Pietro, the session is arranged by Caiola, who picks and strums some of the loveliest tunes to stem from the 50th state. Highlighting the album are such items as "Sweet Leilani" and "On The Beach At Waikiki."



ERNEST TUBB & LORETTA LYNN—Decca DL 4639/DL 74639

The combo of Ernest Tubb and Loretta Lynn, currently climbing up the country charts with a single called "Our Hearts Are Holding Hands," use the same tune to highlight this package, which is destined for a quick trip to country hitsville. The huge fan clubs of both of these top bluegrass specialists should get on the scent of this one and bring it on home in short order. Other top notch tracks include the flip of the hit single, "We're Not Kids Anymore" and the well-known "A Dear John Letter."



THE REAL GEORGE KIRBY—Argo 4045

Renowned as a comic and mimic, George Kirby steps out in a legitimate setting on this straight singing performance. The jokester injects humor in a few of the lighter tunes, but shows a capability with ballad and easy swing songs as well. Likely to sell a good many on his reputation, the chanter could pick up the sales pace with a bit of exposure. Among the stand-outs are: "Get Me To The Church On Time," "The Joker" and "This Is The Life."



FEELING GOOD—Xavier Cugat—Decca DL 4672/DL 74672

An artist long associated with Latin-flavored liveliness, Xavier Cugat turns the attention of his volatile orchestra to an assortment of some of the biggest tunes to burst from the current Broadway and rock avenues, all handled with a tropical treatment. Some of the biggies from the Broadway belt include "Hello Dolly" and "Fiddler On The Roof," while the rock area is represented with the recent biggies "Game Of Love" and "Downtown."



NANA—Nana Mouskouri—Fontana MGF 27545/SRF 67545

An artist who has already won critical acclaim throughout Europe for her powerful and sensitive renditions of folkloric material, Nana Mouskouri should establish herself even more strongly here in the U.S. with this thoroughly impressive selection of melodies, handled in her fresh, warm-hearted style. Each tune in this album gets the ful, rich Mouskouri treatment, making the LP a highly enjoyable musical display. Featured tunes include "Johnny" and "I Gave My Love A Cherry."



THAT'S ALL—Mel Torme—Columbia CL 2318/CS 9118

One of the finest romantic chanters, Mel Torme outdoes himself on his latest Columbia offering of selections geared for late night and "good" pop programming. The "velvet fog" drifts in over the exotic Robert Mersey arrangements, and lingers in a gorgeous haze that should find a great appeal both to fans of the vet, and the younger crowd not familiar with his brilliance. Selections include: "The Nearness of You," "The Second Time Around" and "Do I Love You Because."



SKITCH . . . TONIGHT!—Skitch Henderson—Columbia CL 2367/CS 9167

Long a noted orkster, Skitch Henderson's reputation has climbed well beyond its earlier high point via his work on the NBC-TV "Tonight" show, and this could exert a considerable effect on the popularity of this superb Columbia LP. The soft big band selections capture a freshness and vitality on this set that includes softies and swingers. Highlight samplings feature: Hoagy Carmichael's "Heart And Soul," "So What Else Is New?" by Clark Terry, and Henderson's own "Curacao."



TRUMPETS' GREATEST HITS—Bobby Hackett—Epic LN 24155/BN 26155

One of the brightest hornmen around in his own right, Bobby Hackett has recorded a musical tribute to some of the greatest trumpeteers of alltime, including Bix Beiderbecke, Bunny Berigan, Billy Butterfield, Clyde McCoy, Harry James and Ray Anthony, among others. Backed by a lush string orchestra, Hackett does a superb job as he takes on the "theme" songs of the greats and sets them in his own style. Top efforts include "And The Angels Sing" and "Memories Of You."

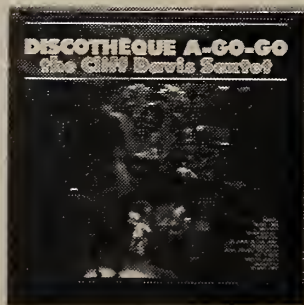

DISCOTHEQUE A-GO-GO—The Cliff Davis Sextet—Epic LN 21173/BN 26173

The percolating percussion of the discotheque dance craze has received another walloping treatment on this Epic outing by the Cliff Davis Sextet. A lively and refreshing group, the sextet lets loose with a raunchy sound and uninhibited beat that's just right for the turbulent steps that have conquered the dance floors around the country. A wild party package, this LP is highlighted by "Twine Time" and "Shot Gun."

A Million Thanks!

... for the tremendous
reception at the Copacabana

... for Five Number One
records in-a-row

... we're hoping

NOTHING BUT HEARTACHES

Motown
1080

will be our sixth.

With Love,

THE **SUPREMES**





BROADWAY BEAT—Stan Worth—RCA Victor LPM/LSP 3362

Stan Worth is a young and relatively unknown performer who, judging from this RCA Victor LP, will soon have a flock of fans to call his own. On this package he displays some of his wide-ranging versatility as he vocalizes some of the biggest tunes to come forth from the Broadway stage, accompanying himself on a very swinging, jazz-flavored piano. Among the grooves that really wail are "Seventy Six Trombones," from "Music Man," and "Sit Down You're Rockin' The Boat," from "Guys And Dolls."



LUCKY 'LEVEN—Jimmy Gilmer—Dot DLP 3642/25643

Jimmy Gilmer and the Fireballs are making a bid for a lot of attention with this package of rhythmic bluesers and rompers, one short of a dozen. The boys kick off the album with a pounding tune called "Boom Boom and continue throughout the session with a whole bunch of raunchy, raucous sounds and "peanut butter" beat. More sides to keep an eye on in this one include the way-backer "The Fool" and the off-cut "High Heeled Sneakers."



THE ELECTRIFYING GUITAR OF WALTER RAIM—Mercury MG 21021/SR 61021

The electric guitar is used to its utmost in this lovely tour de force by Walter Raim, whose magic handling of the instrument makes this an LP that could catch a good deal of pop and good music attention. Basically soft in its tempo and tone, the LP never lacks a liveliness which makes for fine entertainment. Among the finest of the twelve tracks included are: "The Teacher," "I Will Wait For You" from "The Umbrellas of Cherbourg" and "Amen."

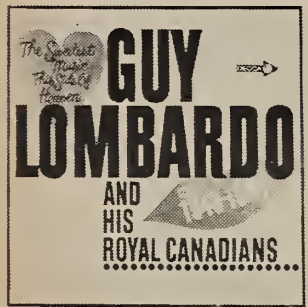

THE SWEETEST MUSIC THIS SIDE OF HEAVEN—Guy Lombardo & His Royal Canadians—Decca DL 4329/74329

The fourth album in a series of Guy Lombardo's pleasurable musical biography, this one covers the years 1949-1954, and features the maestro leading his Royal Canadians through some of the biggest hits of those years. Just right for the collectors of Lombardo music, this album is filled with an abundance of the orkster's easy music, highlighted by such memorables as "Enjoy Yourself" and "A Thousand And One Nights," in addition to "Young At Heart" with a vocal by Bing Crosby.

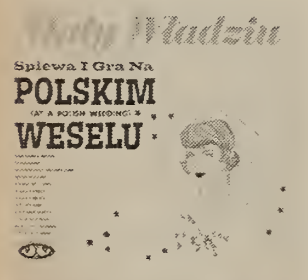

POLISH WEDDING ALBUM—Li'l Wally—Jay Jay 1089

Long standing leader in the polka album field, Li'l Wally bows another set loaded with appeal to the Polish fans and other admirers of the lively dance. Featuring favorites with Ethnic appeal on this "Polish Wedding Album," the orkster serves up some splendid somewhat soft and highly lively selections. Among those included are: "Dzisiaj Jesta Wesele" (Today Is The Wedding), "W Sali Karuzeli" (Wedding At The Carousel) and "Zapoznanie" (Get Acquainted).



NIGHT AND DAY—Parris Mitchell Strings—Pickwick 33 PC/PCS 5005

Quickly becoming a popular orchestral unit, the Parris Mitchell is well represented on this outing in the budget priced Pickwick 33 line by lovely readings of ten standards. Tailor made for late night spinning, the set features the lush sound of the string combo in performances of romantic tracks like: "You Stepped Out Of A Dream," "Heart And Soul" and "I Dont Want To Walk With You." Beautifully packaged, the line itself is a draw to consumers, and this package is easily worth twice its price.

JAZZ PICKS

UP TO DATE WITH EARL HINES—RCA Victor LPM/LSP 3380

Since his New York concert series of last year, Earl Hines has rocketed on the recognition scene, with LP's coming hot and heavy from several diskeries. The latest of these releases heads up the RCA Victor jazz drive, and features "Fatha" swinging with Bud Johnson, Ray Nance and Jimmy Crawford. Showcasing the genius of Hines, the LP spotlights tracks like: "A Cottage For Sale," "The Hour Of Parting" and "Wrap Your Troubles In Dreams."



ERIC DOLPHY IN EUROPE, VOL. 2—Prestige 7350

The wealth of material that has been released as a result of the death of Eric Dolphy has been responsible for bringing out both the best and the worst of this sax-flautist. Showing the musician nearing the peak of his genius, this selection of tracks, recorded in Denmark, presents Dolphy in the company of three Scandinavian sidemen who are well worthy of note. Keeping with the leader during these wide open sessions, all four performers stand out, with amazing showings on "The Way You Look Tonight" and "Miss Ann."

JAZZ BEST BETS



TESTIFYIN' TIME—Bunky Green—Argo 753

Sax wailing steeped in the r&b tradition marks the sound of Bunky Green and the sextet that turns in a fine series of performances on this wide open and wild moving session. Featuring a collection of swing and rock tunes, the combo works up a storm of up-tempo tempters fitted for lively spinning. Among the eight tracks are: "Silver Dollar," "Tweedlee Dee" and a quartet reading of "On Green Dolphin Street." Sweet stuff here.



GREAT MOMENTS IN JAZZ RECREATED AT THE NEWPORT JAZZ FESTIVAL—Various Artists—RCA Victor LPM/LSP 3369

The collector's item sound recorded on this LP was a recreation of some of the high spots in the late dixie-early swing era. Cut at the '64 edition of the Newport Jazz Festival, the set features tracks offered as an homage to the figures of the bygone age, with the greats performing their famous selections. Among the tunes included are "Sweet Georgia Brown," "Big Noise From Winnetka" and "Stars Fell On Alabama." Should attract jazz faithfuls.

CLASSICAL PICKS



BRAHMS: SONATA NO. 3 FOR VIOLIN AND PIANO/SINDING: SUITE/RAVEL: TZIGANE; Heifetz; RCA Victor LM 2836

The unique collaboration of Heifetz and Kapell on the three sonatas for violin and piano by Brahms has long been a collector's item, and the final work is highlighted on this reissue of the 1950 recording. Also including the "Suite, Op. 10" by Christian Sinding and the remarkably performed "Tzigane" of Maurice Ravel, this RCA Victor set should become a much sought after catalog item. Orchestral support is rendered by the Los Angeles Philharmonic, Alfred Wallenstein conducting.



CARNEGIE HALL RECITAL; Shirley Verrett; RCA Victor LM/LSC 2835

A mezzo-soprano who has earned every bit of the overwhelming critical acclaim she has received, Shirley Verrett is exquisitely spotlighted in this recording made at her Carnegie Hall recital of Jan. 30, 1965. The artist performs a wide range of material, including art songs and folk ballads as well as aria excerpts. Tracks include: Mozart's "Alleluia" from the "Exsultante, Jubilate;" "He's Goin Away" and several songs by Schubert. Excellent performance.

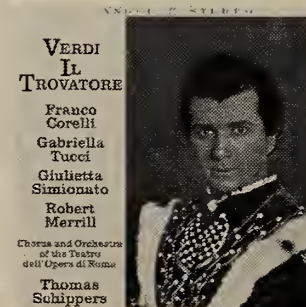

VERDI: IL TROVATORE; Corelli, Tucci, Merrill; Angel SCL 3653

Featuring an excellent cast, superior recording techniques and magnificent orchestral support by the Orchestra of the Teatro dell'Opera di Roma conducted by Thomas Schippers, this should become an extremely popular performance of the well-known Verdi opus. Artists include Franco Corelli (the subject of an intensive promotion), Gabriella Tucci and Robert Merrill. An excellent reading of the complete work on three-disks, including photographic text.



MADRIGALS AND INSTRUMENTAL MUSIC—Telemann Soc. Chorus—Counterpoint/Esoteric 618/5618

The only American organization that has been regularly recording music of the English Renaissance and following era, the Telemann Society has approached the authentic presentation of this music through the development of "pararhythmic integration." In its latest series of packages, the ensemble performs in precise and brilliant style, here presenting works of Morley, Pilkington and others. Fanciers of Madrigals will be enthusiastic over this offering.

You must hear

CONNIE FRANCIS

sing **ROUNDABOUT**

K-13389

Arranged & Conducted by Tony Hatch

MGM Records is a division of Metro-Goldwyn-Mayer, Inc.

MGM



RECORDS





RADIO ACTIVE CHART

A survey of key radio stations in all important markets throughout the country to determine by percentage of those reporting which releases are being added to station play lists this week for the first time and also the degree of concentration combining previous reports. Percentage figures on left indicate how many of the stations reporting this week have added the following titles to their play list for the first time. Percentage figures on right include total from left plus the percentage title received in prior week or weeks. (SURVEY COMPLETED TO AUGUST 4TH)

% OF STATIONS ADDING TITLES TO PROG. SCHED. THIS WEEK	TITLE	ARTIST	LABEL	TOTAL % OF STATIONS TO HAVE ADDED TITLES TO PROG. SCHED. TO DATE
41%	Danger Heartbreak Dead Ahead—	Marvelettes—	Tamla	41%
40%	It Ain't Me Babe—	Turtles—	White Whale	96%
39%	Houston—	Dean Martin—	Reprise	90%
35%	Annie Fanny—	Kingsmen—	Wand	48%
34%	Heartaches By The Number—	Johnny Tillotson—	MGM	34%
33%	Who'll Be Next In Line—	Kinks—	Reprise	45%
32%	I Don't Wanna Lose You Baby—	Chad and Jeremy—	Columbia	61%
31%	We Gotta Get Out Of This Place—	Animals—	MGM	38%
30%	Action—	Freddie Cannon—	Warner Bros.	39%
29%	Since I Lost My Baby—	Temptations—	Gordy	49%
28%	I Need You—	Impressions—	ABC Paramount	28%
27%	Sad, Sad Girl—	Barbara Mason—	Arctic	60%
26%	Simpel Gimpel—	Horst Jankowski—	Mercury	34%
25%	Moonlight And Roses—	Vic Dana—	Dolton	41%
25%	Eve Of Destruction—	Barry McGuire—	Dunhill	25%
24%	Two Different Worlds—	Lenny Welch—	Kapp	50%
23%	Heart Full Of Soul—	Yardbirds—	Epic	91%
22%	The In Crowd—	Ramsey Lewis—	Argo	86%
22%	Colours—	Donovan—	Hickory	54%
21%	Shake And Fingerpop—	Jr. Walker and All Stars—	Soul	67%
21%	I'll Take You Where The Music's Playing—	Drifters—	Atlantic	49%
20%	Give All Your Love To Me—	Gerry and Pacemakers—	Laurie	20%
19%	You've Got Your Troubles—	Fortunes—	Press	19%
18%	These Hands (Small But Mighty)—	Bobby Bland—	Duke	18%
17%	Only Those In Love—	Baby Washington—	Sue	46%
16%	You've Been In Love Too Long—	Martha & Vandellas—	Gordy	16%
15%	The Sweetheart Tree—	Johnny Mathis—	Mercury	29%
14%	I'm A Happy Man—	Jive Five—	UA	88%
13%	It's The Only Way To Fly—	Jewel Akens—	Era	25%
12%	Summer Nights—	Marianne Faithfull—	London	21%
11%	Oowee, Oowee—	Perry Como—	RCA	58%
10%	Sugar Dumplings—	Sam Cooke—	RCA	76%

LESS THAN 10% BUT MORE THAN 5%

TITLE	ARTIST	TOTAL % TO DATE	TITLE	ARTIST	TOTAL % TO DATE
Where Were You When I Needed You	Jerry Vole (Columbia)	17%	Lough At Me	Sonny (Atco)	9%
If You Wait For Love	Bobby Goldsboro (UA)	16%	Do You Believe In Magic	The Lovin' Spoonful (Komo Sutra)	8%
Mohair Som	Charlie Rich (Smash)	9%	Too Hot To Hold	Mojo Lince (Okeh)	8%
			The World Through A Tear	Neil Sedaka (RCA)	7%
			What Are We Going To Do	David Jones (Colpix)	32%

Jackie Ross

WE CAN DO IT

CHESS 1940

Ramsey Lewis Trio

THE "IN" CROWD

ARGO 5506

The Radiants

WHOLE LOT OF WOMAN

CHESS 1939

James Phelps

LA DE DA I'M A FOOL IN LOVE

ARGO 5509

Little Milton

Without My Sweet Baby

CHECKER 1118

CHESS

RECORDS

DUNHILL

NOT JUST A COMPANY THAT MAKES RECORDS
...BUT A RECORD COMPANY



THE EVE OF DESTRUCTION

**JUST THE BEGINNING
FOR A GREAT ARTIST**

BARRY MCGUIRE

D-4009

AND A GREAT WRITER

P. F. SLOAN

EXCLUSIVELY DISTRIBUTED BY ABC PARAMOUNT

Starday Appoints Campus Its Florida Distributor

NASHVILLE—Jim Wilson, national sales manager of Starday Records, announced last week that Campus Record Distributors of Miami, Fla. has been appointed distributor for all the label's product in the Sunshine State.

A Truly Inspiring Performance

STEREO

stevie hawkins



THE SPIRITUAL SOUL OF A CHILD
STEVIE HAWKINS
CHECKER LP/LPS 10010

CHESS

RECORDS



Old Town Inks Bubber Johnson

NEW YORK—Old Town Records has inked Bubber Johnson, songwriter and writer, to a disk pact, according to the label's Hy Weiss. Johnson will cut his first sides for the label on Aug. 15. Weiss said that plans call for Johnson to be developed both as a singles and LP attraction.



ALBUM PLANS

Deals, discounts and programs being offered to dealers and distributors by record manufacturers.

ABC PARAMOUNT—IMPULSE

12½% discount offered on all album product including new and catalog items. Expiration date indefinite.

AMY-MALA

One album free with every seven purchased, offer good on all catalog LP's. No termination date given.

AUDIO FIDELITY

2 on 10 sales deal for new and catalog product except 'First Component Series,' which is offered on a special deal. Offer continues through Sept. 30.

DECCA-CORAL

Special terms available on new and catalog product through distrib. Offer ends Sept. 3.

DIAMOND

Buy 7, get 1 free on special LP's Offer good through Sept. 30.

FORTUNE

1 free album when 6 are purchased in any combination. No time limit.

FOUR CORNERS

15% discount available on new and catalog LP's. Dated billing offered to qualified dealers. Terminates Sept. 25.

GATEWAY

Two free for every 10 albums purchased on entire catalog. Expiration date indefinite.

KAPP

Special discounts and dated billing arrangements available through distrib. Effective until the end of the year.

MERCURY

10% discount catalog LP's and 12% on new releases. Expiration date unknown.

NASHBORO

Buy-7-get-one-free on entire catalog including new LP's. 100% exchangeable. No expiration date has been set.

ORIGINAL SOUND

1 LP free for each 10 purchased less 3% cash discount. No expiration date.

PRESTIGE-STATUS

15% discount on all Prestige LP product until further notice. Discount on Status albums, details through distrib.

REQUEST

LP catalog available on a buy-10-get-2-free basis. Described as a limited-time offer.

ROULETTE

15% discount in free merchandise. Expiration date indefinite.

SCEPTER-WAND

2 Albums free with every ten purchased. No termination date announced.

SMASH-FONTANA

Special discounts available through distrib. Expiration date not announced.

TAMLA-MOTOWN-GORDY

Buy-7-get-1-free. Expires: No time limit.

VANGUARD

Aug. Re-Stocking Plan: 10% discount on folk and Everyman LP's, mono and stereo; 20% discount on Bach Guild and Vanguard classics, mono and stereo.

VEE JAY

10% discount on LP's.

WORLD ARTISTS

10% discount on LP's. No expiration date announced.

WORLD PACIFIC

10% discount, extra 5% on LP orders of 100 or more on any item.

REDD FOX

on Dooto's
Best Selling
Comedy Albums



★ **Load Up Now For** ★
Big Holiday Sales!

DEALERS ORDER NOW! 5 plus 1 DEAL!

Over 50 Red Hot Catalog Items

DOOTO RECORDS 9512 S. Central, Los Angeles 2, Calif.

SO FAR OUT IT'S OUT OF SIGHT!

Listen To It . . . You'll Never Believe

"HUNGRY FOR LOVE"

by the **SAN REMO GOLDEN STRINGS Ric-Tic 104**

THE R & B SLEEPER OF THE YEAR!

GOLDEN WORLD RECORDS

3246 West Davison
Detroit, Mich.
(313) 883-7843



AUDIO-VISUAL SPECIAL PRODUCTS PERSONNEL—Columbia Records' newly formed Audio-Visual section poses for a "team" photo with Joseph Carlton, who was just named executive producer directing A&R activities for the unit, coordinating the literary and musical production with creative and technical activities. Having produced over 22 gold records during his career, Carlton (back row, second from right) is shown with his associates: (standing, left to right) William Levy, manager of marketing services; Sondra Bianca, recording supervisor; and Norman Dahl, account exec. Seated are: Albert Shulman, CSP vice president; Joel O'Hayon, section manager; Sue Atkins, systems analyst; Martin Weiss, premium sales administration manager; and Roger Minkoff, account executive.

NOW... SONNY HAS A HIT OF HIS OWN... WITH A POWERFUL MESSAGE!



LAUGH AT ME

Atco 6369

Arranged and Produced by: SONNY BONO
A YORK-PALA Production
Chas. Greene/Brian Stone

THE SHINDIG PICK OF THE WEEK!
Watch Sonny perform it August 11

LAUGH AT ME
WHY CAN'T I, BE LIKE ANY GUY
WHY DO THEY TRY TO MAKE ME RUN, SON OF A GUN
WHAT DO THEY CARE, ABOUT THE CLOTHES I WEAR
WHY GET THEIR KICKS FROM MAKIN' FUN
THIS WORLD GOT A LOT OF SPACE
AND IF THEY DON'T LIKE MY FACE
IT AIN'T ME THAT'S GOIN' ANYWHERE
SO I DON'T CARE
THEN LAUGH AT ME,
IF THAT'S THE FARE I HAVE TO PAY TO BE FREE
THEN BABY, LAUGH AT ME
AND I'LL CRY FOR YOU
AND I'LL PRAY FOR YOU
AND I'LL DO ALL THE THINGS
THAT THE MAN UPSTAIRS SAYS TO DO
I'LL DO 'EM FOR YOU, I'LL DO 'EM FOR YOU
IT'S GOTTA START SOMEPLACE
IT'S GOTTA START SOMETIME
I'LL MAKE THAT OTHER CHEEK MINE,
AND MAYBE THE NEXT GUY, THAT DON'T WEAR A SILK TIE
HE CAN WALK BY AND SAY HI, SAY HI, INSTEAD OF WHY

© 1965 Cotillion Music Inc., and Five West Music Publishing Corp.
Words and music by Sonny Bono

Current
SONNY & CHER
Smash:
I GOT YOU BABE

Atco 6359

JUST RELEASED!
SONNY & CHER'S
FIRST LP
LOOK AT US

Atco LP 33-177 (mono & stereo)



ATCO RECORDS · 1841 Broadway · New York, New York 10023 (212) PL 7-6306

26 Years
BLUE NOTE
1st Name in Jazz
RECENT RELEASES



SONG FOR MY FATHER
HORACE SILVER
BLP 4185

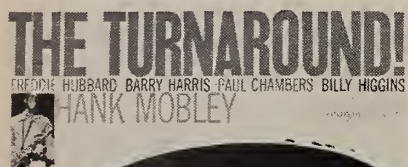

THE TURNAROUND
HANK MOBLEY
BLP 4186



FREE FOR ALL
ART BLAKEY & THE JAZZ MESSENGERS
BLP 4170

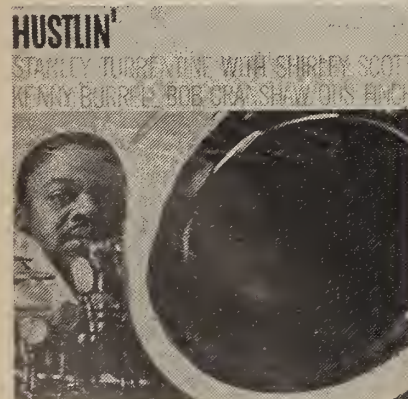

HUSTLIN'
STANLEY TURRENTINE
BLP 4162

COMPLETE CATALOG ON REQUEST

BLUE NOTE
43 W. 61st St., N.Y. 23, N.Y.



TOP 50
IN
R&B LOCATIONS

- 1 PAPA'S GOT A BRAND NEW BAG 7
James Brown (King 5999)
- 2 RIDE YOUR PONY 1
Lee Dorsey (Amy 927)
- 3 IN THE MIDNIGHT HOUR 6
Wilson Pickett (Atlantic 2289)
- 4 TRACKS OF MY TEARS 11
Miracles (Tamla 54118)
- 5 TONIGHT'S THE NIGHT 2
Solomon Burke (Atlantic 8816)
- 6 NO PITY IN THE NAKED CITY 10
Jackie Wilson (Brunswick 55280)
- 7 I CAN'T HELP MYSELF 4
Four Tops (Motown 1076)
- 8 I'LL ALWAYS LOVE YOU 8
Spinners (Motown 1078)
- 9 NOTHING BUT HEARTACHES 13
Supremes (Motown 1080)
- 10 IN CROWD 15
Ramsey Lewis (Argo 5506)
- 11 PRETTY LITTLE BABY 3
Marvin Gaye (Tamla 54117)
- 12 IT'S A MAN DOWN THERE 19
G. L. Crockett (Four Brothers 445)
- 13 BOOT-LEG 9
Booker T & MG's (Stax 169)
- 14 IT'S TOO LATE, BABY, TOO LATE 16
Arthur Prysock (Old Town 1183)
- 15 SINCE I LOST MY BABY 22
Temptations (Gordy 7043)
- 16 WHO'S CHEATING WHO 12
Little Milton (Checker 1113)
- 17 SUGAR DUMPLING 28
Sam Cooke (RCA Victor 863)
- 18 YES I'M READY 14
Barbra Mason (Arctic 105)
- 19 UNCHAINED MELODY 27
Righteous Bros. (Phillys 129)
- 20 ONLY THOSE IN LOVE 18
Baby Washington (Sue 129)
- 21 WE'RE DOING FINE 30
Dee Dee Warwick (Blue Rock 4027)
- 22 YOU'RE GONNA MAKE ME CRY 34
O. V. Wright (Back Beat 548)
- 23 I WANT CANDY 17
Strangeloves (Bang 501)
- 24 IT'S THE SAME OLD SONG 20
Four Tops (Motown 1081)
- 25 WATERMELON MAN 21
Gloria Lynne (Fontana 1511)
- 26 AGENT OO SOUL 37
Edwin Starr (Ric Tic 103)
- 27 LOVE ME NOW 25
Brook Benton (Mercury 72446)
- 28 I'VE CRIED MY LAST TEAR 33
O'Jays (Imperial 66121)
- 29 SAD, SAD GIRL 39
Barbara Mason (Arctic 108)
- 30 ONE STEP AT A TIME 23
Maxine Brown (Wand 185)
- 31 I'LL TAKE YOU WHERE THE MUSIC'S PLAYING 40
Drifters (Atlantic 2298)
- 32 HERE I AM 24
Dionne Warwick (Scepter 12104)
- 33 GOOD TIMES 42
Gene Chandler (Constellation 160)
- 34 TAKE ME BACK 26
Little Anthony & Imperials (DCP 1136)
- 35 GOT TO FIND A WAY 45
Harold Burridge (Impact 7228)
- 36 LET'S DO IT OVER 41
Joe Simone (Vee Jay 694)
- 37 SHAKE AND FINGERPOP 48
Jr. Walker & All Stars (Soul 35013)
- 38 BABY I'M YOURS 31
Barbara Lewis (Atlantic 2283)
- 39 IF I DIDN'T LOVE YOU 43
Chuck Jackson (Wand 188)
- 40 DO THE 45 46
Sharpees (One-Der-Ful 4835)
- 41 I WANT TO (DO EVERYTHING FOR YOU) —
Joe Tex (Dial 4016)
- 42 YOU'VE BEEN IN LOVE TOO LONG —
Martha & Vandellas (Gordy 7045)
- 43 COME BACK BABY 47
Nella Dodds (Wand 187)
- 44 THESE HANDS (SMALL BUT MIGHTY) —
Bobby Bland (Duke 385)
- 45 THAT GOES TO SHOW YOU 50
Garnet Mimms (United Artists 887)
- 46 DANGER HEARTBREAK DEAD AHEAD —
Marvelettes (Tamla 54120)
- 47 TOO HOT TOO HOLD —
Major Lance (Okeh 7726)
- 48 FOR YOUR LOVE —
Sam & Bill (Joda 100)
- 49 WHOLE LOTTA WOMAN —
Radiants (Chess 1939)
- 50 I NEED YOU —
Impressions (ABC Paramount 10710)



JUKE BOX OPS'
RECORD GUIDE

ACTIVE with OPS

(Selections NOT on Cash Box Top 100 reported going strongly with ops.)

- THE SWEETHEART TREE**
Debbie Reynolds (ABC Paramount 10709)
- TILL THE END OF TIME**
Tams (ABC Paramount 10702)
- ALLEY CAT DANCE**
Bent Fabric (Atco 6363)
- DON'T CRY JOE**
Georgia Gibbs (Bell 626)
- THE TURNAROUND Part I**
Hank Mobley (Blue Note 1915)
- LOVE THEME FROM "THE SANDPIPER"**
Peggy Lee (Capitol 5469)
- MY DOG CAN'T BARK**
Muddy Waters (Chess 13935)
- WHOLE LOT OF WOMAN**
Radiants (Chess 1939)
- (THE RING ON MY FINGER IS) WHAT JOHNNY GAVE ME**
Pete Seeger (Columbia 43349)
- THAT'S ALL/I LOVE YOU**
Mel Torme (Columbia 43220)
- MILLIONS OF ROSES**
Steve Lawrence (Columbia 43362)
- WALKIN' DOWN THE LINE**
Joe & Eddie (Crescendo 353)
- 1-2-3**
Len Barry (Decca 31827)
- SALT WATER GUITAR**
Burl Ives (Decca 31811)
- STAND BY ME**
Earl Grant (Decca 25674)
- TEN SECONDS TO HEAVEN**
Ventures (Dolton 308)
- WHEN I WAS YOUNG**
Eddie Fisher (Dot 16753)
- NOBODY KNOWS YOU WHEN YOU'RE DOWN & OUT**
Damita Jo (Epic 9821)
- TWO LITTLE LOVE BIRDS**
Travis Wammack (Era 210)

- LONELY STREET**
Gloria Lynne (Everest 2059)
- YOU CAN'T BUY ME LOVE**
Barbara Lynn (Jamie 1301)
- SPOOTIN'**
Bill Black's Combo (Hi 2094)
- IT'S BREAK UP TIME**
Sue Thompson (Hickory 1328)
- IT'S STARTING TO GET ME**
Irma Thomas (Imperial 66120)
- I'M HENRY THE VIII**
Danny Davis & Nashville Strings (MGM K 13374)
- GOT TO FIND A WAY**
Harold Burridge (M-pac 7225)
- I LEFT MY HEART IN SAN FRANCISCO**
Fats Domino (Mercury 72463)
- DON'T WISH YOUR HEARTBREAK ON ME**
Lou Monte (Reprise 0384)
- ME & MY SHADOW**
Nelson Riddle (Reprise 0386)
- THERE THEY GO**
Exciters (Roulette 4632)
- I'LL TAKE SWEDEN**
Jack LaForge (Regina 1330)
- HEARTACHE (HURRY ON BY)**
Roy Hamilton (RCA Victor 8641)
- THE FAT CAT**
Si Zentner (RCA Victor 8634)
- THE SILENCE**
Al Hirt (RCA Victor 8653)
- LIFE**
Joe Leahy (Tower 150)
- THE KNACK**
Ferrante & Teicher (United Artists 903)
- ONE DAY LOVE**
Tommy Dodson (Uptown 709)
- RAINY DAY**
Rooftop Singers (Vanguard 35029)
- THE SHADOW OF YOUR SMILE**
Astrud Gilberto (Verve 10358)

NEW ADDITIONS to TOP 100

- 65—**WE GOTTA GET OUT OF THIS PLACE**
Animals (MGM 13382)
- 79—**TICKLE ME (EP)**
Elvis Presley (RCA EPA 4383)
- 80—**EVE OF DESTRUCTION**
Barry McGuire (Dunhill 4009)
- 85—**ACTION**
Freddie Cannon (Warner Bros 5645)
- 86—**IT'S A MAN DOWN THERE**
G. L. Crockett (Four Bros 445)
- 87—**DANGER HEARTBREAK DEAD AHEAD**
Marvelettes (Tamla 54120)
- 88—**GIVE ALL YOUR LOVE TO ME**
Gerry & Pacemakers (Laurie 3313)
- 97—**MY GIRL SLOOPY**
Little Caesar & Consuls (Mala 512)
- 99—**HANG ON SLOOPY**
McCoys (Bang 506)
- 100—**YOU'RE GONNA MAKE ME CRY**
O. V. Wright (Back Beat 548)
- 100—**SUMMER NIGHTS**
Marianne Faithfull (London 9780)



Arnold Maxim To Meet European Affiliates

NEW YORK—Arnold Maxim, executive head of the Big Three pubbery took off for England last week to discuss the firm's current overseas musical action with Fred David, Bert Corri and Eddie and David Day of Francis, Day & Hunter; Ben Nisbet of B. Feldman & Co. and Alan Holmes of Robbins Music.

KING FOR A DAY—Bill Tallant, vice president and national sales manager of Capitol Records' Distributing Corp., was congratulated by diskery head Alan Livingston during the recent festivities that celebrated his 20th anniversary with the firm. The celebration, held in the Capitol tower, was highlighted by the presentation of a 20 year pin to the day's kingpin.

He will also confer with Maurice Jarre who is completing the "Dr. Zhivago" score, and will then hop to the Continent for confabs at the firm's Paris branch. Big 3 continental affiliates are currently riding high in France, Belgium and Holland with music from "Zorba The Greek."

thanks a million, deejays.

"IF I DIDN'T LOVE YOU"

Wand 188

*your strong support has
made the record a smash!*

CHUCK JACKSON



ITINERARY

July 22 - 24
Basin Street East, N.Y.C.
July 26 - Aug. 1
Forty Thieves, Hamilton,
Bermuda
Aug.
6 - Indianapolis, Ind.
7 - Youngstown, Ohio
8 - Saginaw, Mich.
9 - Detroit, Mich.
10 - Advise
11 - Milwaukee, Wisc.
12 - Minneapolis, Minn.
13 - Advise
14 - Dayton, Ohio
15 - Columbus, Ohio
16-17 Open
18 - Oklahoma City, Okla.
19 - Longview, Texas
20 - Beaumont, Texas
21-22 Houston, Texas
24 - Lubbock, Texas
25 - El Paso, Texas
26 - San Antonio, Texas
27 - Galveston, Texas
Sept. 2
Clay Cole TV Show
Sept. 3 - 9
Apollo Theatre, N.Y.C.
Sept. 10
Newburgh, N. Y.—
Tradewinds
Sept. 11 - Oct. 10
One Nighter Tour—
Cities to be announced

Personal Management:

Wand Management Corp.

254 West 54 Street
New York, N.Y. 10019
Paul Cantor, Vice President

Direction:

SHAW ARTISTS CORPORATION
565 Fifth Avenue
New York 17, N.Y.



RECORD RAMBLINGS

NEW YORK:

The shifting scene at the Forest Hills Music Festival covered two major areas previously not represented at the program's sessions, rock and jazz. The bill featured Trini Lopez, with Stan Getz and Woody Allen, certainly headliners in their own right, as warm-up attractions. Due to an airline "hang up," Getz was unable to make the show, but providing ample satisfaction to the jazz buffs on hand, Herbie Mann turned up with a team of "the fastest dressing musicians in the business." Allen covered for a bit of spare time in an extra stint prior to the sextet's session; and from then on it was Latin-pop-folk-romancer fare from the vivid Reprise artist. Lopez proved once more that his flare for entertaining is not limited to recording studios or nighteries, as he brought the concert crowd to life eliciting support in the form of finger-snapping, hand-clapping and a series of sing-alongs. Aside from his artistic talents, the chanter's most useful asset is his ability to invigorate his audience, leaving each viewer with the pleasure of both hearing, and participating. Most of the folk will be happy to hear that Lopez' new outing "The Rhythm and Blues Album" is now in release. Meanwhile, he was off to Monaco for a Red Cross charity show last week. . . . The 15,000 seat stadium was also sold-out for the Sun. (8) edition of Barbra Streisand's concert. . . . Jody Miller was in town to do her second stand on the Al Hirt "Fanfare" Show bowing her new outing, "Home of the Brave." While in Gotham she made the rounds under the wing of Capitol promo rep Tom Rogan. . . . Another alumnus of the hornman's TV'er, Lesley Gore showcased her "Sunshine, Lollipops and Rainbows" in tapings of an Aug. "Shindig" and

a Sept. "Hullabaloo" stanza. . . . Murray the K has added Jordan Christopher and the Wild Ones and the Supremes to the cast of his half-hour WOR-TV spec. . . . Mary Wells heads at the Hejaz Grotto in New Haven (14) to be followed by a showing at the Minnesota State Fair for five nights starting Aug. 28. . . . The Paulette Sisters are set for a stand this week (11-13) at the Gouverneur in the N. Y. Fair. . . .

A pleasure meeting the Righteous Bros. last week while they were in town for a couple of TV shots, including the "Tonight" show (3). . . . Norman Dello Joio, whose music for the NBC-TV special "The Louvre" has been awarded an Emmy nomination, is busy prepping portions of the score for band. The opus will be published by Marks Music when ready. He's currently at work on a new project for the upcoming ABC drama series, "Moment of Decision" to bow this fall. . . . The Dukes of Dixieland, newly affiliated with Decca, are skedded for a Dean Martin spot Oct. 14. . . . Sue jazz organist Jimmy McGriff is following his Antibes Jazz Fest showing with one-nighters around the French and Italian Riviera. . . . Henny Youngman has cut "The Wreck," his first waxing out of the comedy vein. The tune, recorded for the Brighton label, was inspired by the Wreck Bar at the Castaways in Miami Beach. . . . Otis Polard gets the production credit on the Jive Five's UA hit, "I'm a Happy Man." . . . Mercury's national promo director Morris Diamond honeymooning in New York with his new missus. . . . Al Altman beaming over placement of two Metric tunes in the new Trini Lopez LP, also proud about the action of Chuck Jackson's "If I Didn't Love You" (Wand). . . . Comic George Kirby makes a return appearance on the "Tonight" show (9), where he'll

be doing a couple of songs from his first LP as a vocalist. The Argo offering is tabbed "The Real George Kirby." . . . George Maharis has been signed for a Dec. stand at the Persian Room. The actor-vocalist, who has been cutting with Epic for three years, recently completed a highly successful tour of South America. . . . Al Gaitwood, prexy at Gait Records, announced the pacting of the Profiles, who are currently making promo appearances on behalf of their "Never" and "Right By Her Side" deck. . . . Serendipity Singers back in town at the Bitter End (13) for ten-days. . . .

Talent manager Roy Silver has teamed with Sheldon Schultz to form Triple S Productions, the first project to be a one hour special starring Bill Cosby and featuring Joan Rivers. The

CHICAGO:

The Down Beat Jazz Festival gets underway at Soldier Field 8 (13) for three evenings. A special matinee performance on Saturday (14) will feature a line-up of local stars in "The Evolution Of Chicago-style Jazz." . . . E. Rodney Jones, program director of WVON, and deejay Pervis Spann recently took over management of The Club, a southside nitery located on the site of the old Club DeLisa. Current show spotlights the Syl Johnson Revue starring McKinley Mitchell. . . . The Johnny Dee III, formerly billed as the Pepper Pots, opened at the Villa Moderne in Highland Park. . . . Mahalia Jackson will be waxing a new Columbia album in Chi this week. . . . Argo artist Willy Wright returned to

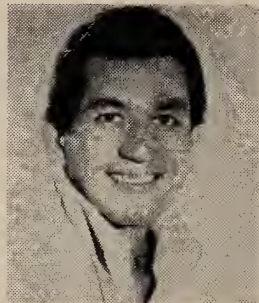

TRINI LOPEZ



PROFILES



SERENDIPITY SINGERS

firm is also working on a series for the new comedienne, whose Warner Brothers debut hit the market this month along with Cosby's third for the diskery. . . . Oscar Brown, Jr. opened at the Cafe Au Go Go for a month. . . . Jerry Ross, formerly of Portem Distribs, buzzes that he's looking for local, label or distrib promo work. . . . Bernie Gurtman and Chuck Brown have merged publicity outfits with headquarters located at 850 Seventh Ave. . . . Denise Germaine headlines at the Three Rivers Inn, Syracuse. . . . Hershy Kay has been signed to do the orchestrations for the new Broadway musical, "Drat! the Cat!", opening at the Martin Beck Oct. 9. His last credits in a similar capacity were for "Milk and Honey" and "110 In the Shade." . . .

the La Montmartre for an indefinite stay. . . . Local promo men gathered at the Carriage House last Tuesday (3) to toast WLS' Gene Taylor on the occasion of his appointment as station manager of the outlet. His former p.d. post will be filled by morning spinner Clark Weber. . . . Summit's Ron Jongsma has been on the move here with White Whale outing "It Ain't Me Babe" by the Turtles. . . . Latest card from Li'l Wally and his troupe is post-marked Belgium. Next stop, England! . . . Paul Gallis stopped by to give us the lowdown on Tony Bennett's new Columbia LP "Tony's Greatest Hits Vol. III"; and singles "I Never Will Forget" by Shirley Ellis (Congress), "King Of The Road" by Bobby Chris-

(Continued on page 200)



ADD A
NEW NAME
TO EPIC'S
GROWING LIST OF
HIT ENGLISH GROUPS

** Gary Farr &
The T-Bones

THEIR FIRST AMERICAN RELEASE
IS A CHARTBUSTER

"Give All She's Got" 5-9832

**GARY FARR IS THE SON OF FORMER BRITISH
HEAVYWEIGHT CHAMPION TOMMY FARR



THE FASTEST
GROWING NAME
IN RECORDED
ENTERTAINMENT



Skeeter Davis
has a new hit single
"Sun Glasses"
c/w "He Loved Me Too Little" - 8642

RCA Victor
The most trusted name in sound

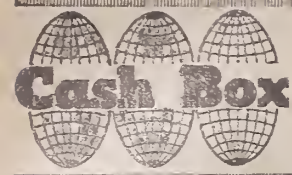

RECORD RAMBLINGS

(Continued from page 198)

tion (Mal) and "Never Again Will I Fall In Love" by Dick Sarlo (Glen). . . . A hearty "welcome back" to Morrie Price, Glenn Miller, and the entire crew of MGM/Verve's new Chi branch Metro Record Dist. . . . In the Dot spotlight, according to Erwin Barg, are Mike Manor's "She's Just A Quiet Girl," Pat Boone's "Rainy Days," Eddie Fisher's "When I Was Young" and "Surfer Joe" by The Surfaris. . . . Sig Sakowicz (WGN-WTAQ) is off on a two weeks vacation trip with his family. . . . Deek Atkins has high hopes for the new Gene Chandler deck "Good Times" (Constellation). . . . Roy Wood (WVON) was guest deejay at Lucky's Inn last week. . . . Decca's Frank Scardino reports hefty action hereabouts on the powerful Dukes of Dixieland package cut "Live At Bourbon Street" and the James Stewart narration "Legend Of Shenandoah" from the current flicker. . . . Julie Godsey was appointed promo rep for Summit Dist.'s line in the Cincy and Southern Ohio area and is currently working on "Let's Have A Beach Party" by the Pleasures (RSVP). . . . With Bobby Garmisa the big ones to watch are "Wish You Didn't Have To Go" by Tommy Roe (ABC) and "Eve Of Destruction" by Barry McGuire (Dunhill).

HOLLYWOOD:

L.A. continues to bang away with bullets—ten of the top 30 singles and fifteen of the top 30 albums on this week's CB chart were cut here. . . . We wonder if the Righteous Bros. are aware of the fact that their current hit "Unchained Melody" was in the CB top ten just ten years ago this week. The artist was Al Hibbler. . . . Fashion note —Sonny Bono, wearing

his new three-quarter length skunk skinned jacket, and with Cher, waved farewell to 2000 fans at International Airport here last week. We now hear that they were refused admittance to the Hilton Hotel when they arrived in London. This, just two weeks to the day that Sonny was booted from Martoni's Restaurant and was thereupon inspired to write "Laugh At Me." Now there's a rumor that Mario and Tony, who own the eatery, are about to cut an "answer" record! . . . If you'd like to fall in love again may we suggest you sample a song—or even a breath—from Nancy Wilson's latest Capitol LP "Gentle Is My Love." She's currently taping the Dean Martin Show and she's our "West Coast Girl Of The Week." . . . Incidentally, Capitol's Bill Tallant is celebrating his 20th anniversary with the firm this week. . . . Snuff Garrett, completing an indie session with Ed Brown of Joe and Eddie for GNP Crescendo, reports the new Gary Lewis album for Liberty will ship this week. . . . Herman's Hermits film the Danny Kaye Show on Aug. 12 and head for Honolulu and the Arena. . . . Freddy Cannon, set for The American Bandstand on Aug. 21, makes San Fernando Valley his home—new address is in Tarzana. . . . Dave McCallum, Emmy nominee for "The Man From U.N.C.L.E.," will co-star with Carol Channing and George Burns in a CBS special to be filmed here on Aug. 29. . . . Ernie Freeman arranged sessions for Dot and Eddie Fisher last week, Edie Adams on Sunday, Chipmunks this Monday, Connie Francis on Wednesday and Connie Stevens on Thursday—what happened to Tuesday? . . . Sam Riddle's "Hollywood A Go Go" TV series, seen in 25 U.S. markets and 10 overseas, has been

inked for another 26 weeks. . . . Don Bohanan, V.P. and General Manager for Hanna Barbera Records, returns this week from a two-week 15-city business tour. . . . Larry Goldblatt and Ken Raphael meeting with N.Y. TV toppers on their Jan and Dean-Roger Christian video special "Beat Beat" which was premiered here last week on KTTV. . . . High on the charts in Modesto, Bakersfield and Stockton with local play on the way are the Brogues whose Twilight Record is titled "But Now I Find." Several local labels bidding for the master. . . . Bob Holliday, promo man and publisher, requests press releases on current artists—address is WKDA in Nashville. . . . There's a new teenage nightclub on the strip with Bobby "Let Her Dance" Fuller the current attraction.

HERE AND THERE:

PHILADELPHIA—Matty's "Humdinger" Singer tabs Barry McGuire's "Eve of Destruction" the "biggest deck of the year." More goodies from the ABC studios include Tom and Jerrio's "Great Goo-Ga-Moo-Ga" and "I Need You" by the Impressions. This week's advice: "Be yourself! If that doesn't satisfy, improve yourself." . . . Buzz Curtis touts smash sales showings by the Exceptions with "Down by the Ocean" (Cameo); "Do You Believe in Magic" by the Lovin' Spoonful (Kama-Sutra); Dean Martin's "Houston" (Reprise); and "What Are We Going to Do" from David Jones (Colpix). . . . Hefty movers in this area according to Ron Singer are: "Who'll Be Next in Line"



SONNY & CHER



NANCY WILSON

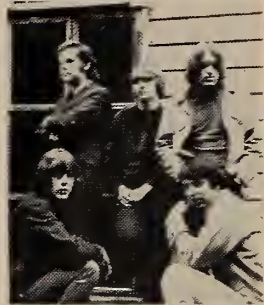

BROGUES

Club was formerly—alas—the redolent Giro's. . . . Currently at The Dunes in Vegas is Bill Carey whose initial outing for Dot is "That Girl" b/w "I Am," the Tony Bennett hit of yesteryear. . . . Johnny Mandel has been signed by producer Jimmy Komack to compose the original theme for WB's "Mr. Roberts" series starring Roger Smith. . . . The Supremes will be arriving here later this month to cut their Xmas album. . . . And the Smother Bros.' latest Mercury album, we hear, is being tested by The National Education Association in S.F. as a kindergarten teaching device—it's titled "Aesop's Fables"—and we'd guess that the press release from McFadden, Strauss, Eddy and Irwin belongs in the LP.

by the Kinks, James Darren's "Because You're Mine" and "Action" with Freddy Cannon. . . .

Joe Bertotta of P&R Distribs sends along word about HBR singles stirring up a lot of excitement here: "Roses and Rainbows" from Danny Hutton, and "I Don't Believe You" by the Guilloteens. . . .

BALTIMORE—This city has given the high sign to both sides of the Righteous Bros. "Hung On You" and "Unchained Melody" deck according to Dave Carrico, whose other sales leaders at Marshall-Mangold include: "Ride Your Pony" from Lee Dorsey, Eddie Rambeau's "My Name is Mud" and he ecstatically touts smash for "What Are We Going to Do" from David Jones.

"I Got You Babe"

Sonny & Chér

Atco #6359

"All I Really Want To Do"

Chér

Imperial #66114

Arranged & Produced by

Sonny Bono

york-pala
RECORDS

CHARLES GREENE

BRIAN STONE

THE PUBLIC DEMANDED IT!

OVER 150,000 ADVANCE ORDERS!

A SMASH BEFORE RELEASE

NOW AVAILABLE AS A SINGLE

“CATCH US IF YOU CAN”

5-9833

THE DAVE CLARK FIVE

Released from their hit album, HAVING A WILD WEEKEND



LN 24162/BN 26162 STEREO



THE FASTEST GROWING NAME IN RECORDED ENTERTAINMENT

Tillotson On Tour Of Country Fairs

NEW YORK—Johnny Tillotson, will start an extensive six week tour of the nation's county fairs on Aug. 12. The tour will carry the MGM chanter into nine states and he'll appear at 11 fairs, with the final appearance at the Rutland, Vt. Fair on Sept. 7.

On his list of scheduled stops are the Indiana Fair in Bloomington, Aug. 12; Iowa Fair in Davenport, Aug. 14; Michigan Fair in Escanaba, Aug. 17; Illinois Fair in Pocatonia, Aug. 21; Ohio Fair in Lisbon, Aug. 26; New York Fair in Bath, Aug. 27; Indiana State Fair, Aug. 28-29; and then the Vermont Fair in Rutland, Sept. 7.

Tillotson will also appear at the Monticello Country Club in Monticello, Iowa on Aug. 25.

2 POWERFUL GOSPEL ALBUMS

SWANEE QUINTET Singing

"SONGS THAT LIFT THE SOUL"

NASHBORO LP 7026

Nashboro LP 7026

Living Gospel Songs

by EDNA GALLMON COOKE

Nashboro LP 7025

177 3rd Ave. No., Nashville, Tenn.

The Jagiello SOUND

IS COMING TO TOWN!



4 Corners Fall Drive Features 5 New LP's

NEW YORK—At sales conferences in New York and Los Angeles, Bud Katzell, head of Four Corners Records, announced the label's plans for its fall drive. The program will include discounts available to distributors and dealers and a new promotion incentive plan both focusing around the new product, which will include five LP's.

In addition to the sales aids being offered for the new product, the label initiated a "4 Corners . . . 4 Market Bonus" program which will operate in the following manner: Specific singles will be designated for the plan. After an initial order of 1,000 or more has been made for these decks, a re-order of a thousand or more will earn the promotion man covering that distributor's market a bonus of \$100. When the side begins to reach the Cash Box Top 100 charts, the first four men to have earned bonuses on that record will be awarded additional checks of \$100 when the record reaches the top 50, again as it hits the top 20, yet again if it climbs into the top ten, and another \$100 if it reaches the top 5. The promotion men can thus earn as much as \$500 on a single disk. Should a specific "cut" in an LP attract enough attention to be released as a single it would automatically be designated a "bonus" record. In this event, the promo man responsible for reporting the reaction, thus starting consideration of the release, will be entitled to earn in the cash bonus program. The plan does not apply to records sold on a guarantee basis.

The Four Corners catalog is available at a 15% discount during the sales program's duration, which will be effective through Sept. 25. In addition, dated billing is being offered to qualified customers, with payments of 1/2 due on the tenth of Sept., Oct., and Nov.

Five new LP's were also announced for the fall drive. The quintet consists of a new offering from the Gunter Kallman German Chorus and Orch. with Bells, tabbed "Serenade For A Lady In Love," a follow-up to the label's best seller to date, "Serenade For Elisabeth;" and "Maid In Paris" with Francoise Hardy; "Great Themes From Foreign Films" performed by Philip Dante and his Ork; Sergio Franchi's "La Bella Italia;" and "Theme From 'Zorba The Greek' and More Greek Dance Music" by Kyriakos and his Orchestra.

Sizzling So. Calif. Breakout!

THE TORQUAYS

"STOLEN MOMENTS"

b/w

"IMAGE OF A GIRL"

Colpix 782

Produced by Bill Bellman

NEW YORK, NEWARK BREAKOUT

Our Mosquito Forced at Gunpoint To Attend a . . .

"SHOTGUN WEDDING"

by ROY "C"—Black Hawk 12101

JAMEGO RECORDS, INC. 9102 Sutphin Boulevard
Jamaica 35, N.Y. (212) 526-2266

CONTEMPORARY PUBLIC RELATIONS RECORD PROMOTION

representing: Gemcor Records, The Challengers, Mike Clifford, Jack Nitzsche, Sonny and Cher, The Turtles, Barry Young and—why not—YOU?

National publicity 213-CR-1-9179

AF Spotlights 12 Albums In Fall Release Plan

NEW YORK—Herman D. Gimbel, the new president of Audio Fidelity Records, has announced the label's fall program, the first of his projected plans for the expansion and promotion of the label. Harold Drayson, vice president, and Barry Oslander, A&R director, have also come up with a twelve album release package for the drive. Gimbel, in addition to giving his staff the "green light" in exploiting the release and procuring new artists, has stressed that the high standards of quality associated with the firm will be maintained at all times, regardless of the artist or material being recorded.

In conjunction with the Aug. program, the firm is offering a 2-on-10 deal for the entire catalog, with the exception of the "First Component Series," which will be offered on a special deal.

The twelve new albums being included in the company's sales and promotion campaign are spearheaded by five classical LP's, the first activity that the diskery has exhibited in this area. The packages include: Beethoven's Symphony No. 6. "The Pastoral;" Brahms' Concerto No. 2 in B Flat; Schumann's Symphony No. 1 and Concerto in A Minor; Brahms' Symphony No. 1; and a collection of Von Suppe Overtures and Strauss Waltzes.

Other platters being offered simultaneously include: "Among the Stars" the debut of South African lark Renee Raff; "The Singing Priest" by Father Columba McManus; "A Sound Of Their Own" by the Folk Four; "Jazz Tempo-Latin Accents;" a "Library Of Sound Effects" and "More From The Gay 90's."

WB Re-links Connie Stevens; Signs Jobim And Doravil

BURBANK—Mike Maitland, president of Warner Bros. Records, announced last week that Connie Stevens has re-signed an exclusive recording contract with the label.

The lark-thespian, who recently completed filming "Never To Late" on the Warner Bros. lot, will record her first singles, under the new arrangement, in Hollywood on Aug. 11. Connie Stevens has had several best-selling singles for the label including her recent "Now That You've Gone" and "16 Reasons." Producer for the forthcoming sessions will be Jimmy Bowen.

At the same time, Maitland noted that WB had signed agreements with Ray Gilbert and Louis Oliveira, of Rio Cali Productions, calling for the recording services of two of Brazil's foremost composers and conductors, Antonio Carlos Jobim and Doravil Caymmi.

Gilbert and Oliviera, who manage and represent Jobim and Caymmi as well as a number of other Brazilian performers, were largely responsible for the success already enjoyed by Jobim in the U. S.

Jobim's first LP, "The Wonderful World Of Antonio Carlos Jobim," has just been released by the label. Ray Gilbert provided the English lyrics to the Jobim songs in collaboration with the Brazilian author.

Plans are currently being made for the recording and subsequent release of an album by Caymmi, the latter being supervised by Louis Oliviera in Brazil.

MGM Brass To Tour European Offices

NEW YORK—MGM Prexy Mort Nasatir and DGG general manager Jerry Schoenbaum left last week for a round of business meetings with EMI officials and MGM Record reps in England, France and Germany. This will be the label chief's first meeting with his overseas reps and affiliates since taking over the company reins on June 1.

The duo will be accompanied in part by Arnold Maxim, head of the Robbins, Feist and Miller pubbery, who will formally introduce Nasatir to England's top EMI brass, Sir Ted Lewis and Sir Leonard Wood. In addition to which, Maxim, the former MGM topper, will also be conducting his own series of business meets (see separate story).

From England, the MGM execs will then look over the Polydor operation in Paris, holding meetings with Andre Poulain. A greater part of their visit will be spent with DGG officials Kurt Kinkele, Heinz Voigt and Henning Rintelen in Hamburg.

Nasatir plans to make frequent overseas visits so that he can keep in personal contact with the ever expanding overseas operations of the record division.



GOLD IN THEM THAR TRILLS—Mort Nasatir, president of MGM Records, added another gold disk to the growing collection being formed by Herman's Hermits, this one for over one million dollars in sales of their recent smash "Mrs. Brown, You've Got A Lovely Daughter." The team received the award at the Plaza Hotel in New York during the diskery's distributor convention. Shown with Nasatir are: Barry Whitwam, Derek Leckenby, Herman (Peter Noone), Karl Green and Keith Hopwood. Their current hit, "I'm Henry VIII, I Am," which last week topped the Top 100, is currently up for RIAA certification and another plaque.





Phono Sales Show General Decline

WASHINGTON, D.C.—The latest reports from the Electronic Industries Association show that the sales of portable and console phonographs for the month of May have taken a general dip.

Distributor sales of portable/table models totaled 138,662 for May, 1965 as opposed to 136,669 for the same month in 1964 and 194,959 for Apr., 1965. Distributor sales for the January-May period this year totaled 1,036,681, compared with a figure of 771,839 for the comparable period of last year.

Distributor sales of console phonographs in May totaled 51,152, a decline from the 70,682 units sold in the same month last year and the 81,916 units sold in April, 1965. Sales for the first five months of this year totaled 499,617, as compared with the 532,309 figure for the same period last year.

Fowler To Gotham

NEW YORK—Ray Fowler, former producer and chief engineer for Riverside Records, has joined the Gotham Recording Corporation in New York City.

At Gotham, Fowler will report to veep-creative services director Fred Hertz, and will be heavily involved in the firm's regular schedule of public service radio programs and spots, produced for various U.S. government agencies. He will also be involved in several new projects, now being developed.

Prior to his nearly 10-year stint at Riverside, Fowler spent over four years at Reeves Sound.

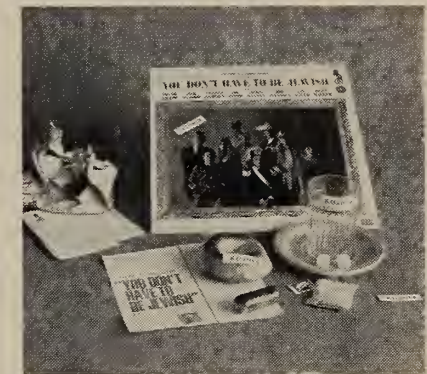

EVERYTHING'S KOSHER — A strictly kosher campaign kit has been issued by Kapp Records to make deejays, dealers and rack jobbers aware of the diskery's new comedy set, "You Don't Have to Be Jewish." The elements shown above set the stage for an 'in' feeling while hearing the LP from the producers of the smash "First Family" platter. The set includes: A genuine kosher salami (for eating while hearing the record); A glass, saucer, tea bag and two lumps of sugar (to wash down the salami); A newspaper wrapped around the contents (for reading, and afterwards to cover freshly waxed floors); A bagel (also handy as a spare skate board wheel); A one-cent stamp (with matzoh ball flavored mucilage); "Kosher" stickers, and the album itself. Word has it that so many of the salamis were eaten by the Kapp (or is it Knapp) staff during packing that an extra supply had to be rushed over for shipping.



AT LIBERTY—The 10th Anniversary celebration party for Liberty Records was marked by a fine turnout of distributors, salesmen, promo hands and diskery V.I.P.'s as can be seen in this photographic record of the welcoming reception, business meeting and dinner dance at the Ambassador Hotel in Los Angeles staged July 30-31. Photos depict: (top row, left to right) Eli Bird (partially obscured), Cleveland promo; Gerry Lacoursiere, midwest promo; Phil Skaff, executive vice president; Mary Dorfman, LDRC of Ohio Sales, and Joe Simone, branch manager with LRDC of Ohio. (Pic. 2) Dick Bowman, southern district manager; Imperial's general manager Ken Revercomb; Liberty gm. Don Blocker; and Big State reps Wright Bordelin, Gene Flores, Ed Broadhurst, Dottie Revercomb, Paul Sheffield and Roy Rogers. (3) Saul Starr and Henry Droz, both of Arc Distributors, Detroit, with president Al Bennett and LRDC of Missouri promo man Jim Saltzman. (4) Mr. & Mrs. Dick Holm, Music Service, Great Falls. (Second row, left to right) Liberty national sales manager Bob Fead, Lou Lavinthal, C&C Distributors in Seattle, Bob Skaff, Liberty veep, and Nate Neves; Bill Biggs, Memphis Record Sales, Phil Skaff, J. P. Bennett and Howard Allison of Southern Distributors; Dottie Revercomb, Harry Rosen of Philadelphia's David Rosen Distributors, Ken Revercomb, and Al Bramey of Melody Sales in San Francisco; Mort Locker, Marie Forsek, Joe Sulich and Betty Ridgewood from Hamburg Bros., Pittsburgh. (Third row) Liberty veep Sy Zucker, Lee Hartstone, Ralph Parsons, Craig Simpson, John Harper and Mrs. Hartstone, Bay Dist., S.F.; Imperial sales manager Rick Frio, Amos Heili-

cher, of Heilicher Bros. in Minneapolis, and Al Bennett; Phil Skaff, Robert Levinson, Herb Dale of Dumont Distributors, Boston, and Jack Pearce, World Pacific national sales manager; Henry Hildebrand, All South Dist., New Orleans, Sy Zucker, Wayne Bennett, Al Bennett, Stan Terry, Memphis Record Sales, Bill Biggs, Lindsley Chandler of Record Sales. (Fourth row) Bernie Block, branch manager of LRDC, New York, Liberty veep Hal Linick, Harry Levin of Cadet in Detroit, and Al Bramey, S.F.'s Melody Sales; International sales director Jerry Thomas, Frasier Jamieson, London Records of Canada, and Al Bennett; Jerry Winston, Wendy Distributors, Newark, Marilyn Fead, Mrs. Jerry Winston and Bob Fead; Al Bennett addressing the audience with Ken Revercomb, Rick Frio, Jack Pearce, World Pacific general manager Dick Bock, Bob Fead, Don Blocker and Sy Zucker seated at the table. (Fifth row) Among others who addressed attendees were: Bob Skaff, marketing director Lee Mendell, Don Blocker, Ken Revercomb and Bob Fead. (Far right) Ross Bagdasarian and Al Bennett admiring special presentation awarded to the Chipmunk creator for record sales in excess of 25 million dollars. (Sixth row) Seated during a speech are Hal Linick, Al Bennett, Bob Skaff, Lee Mendel, Dave Pell and Al LaVinger; new Liberty pactees the Two People; Mel Carter performing "Hold Me, Thrill Me, Kiss Me;" Bobby Vee, who offered a medley of his hits; Al Bennett lighting the cigarette of Julie London while engaged in conversation with Gerald Wilson, whose orchestra was one of the evening's highlights; and Phil Skaff delivering one of the key speeches at the meeting.

Dot Signs Stafford

HOLLYWOOD—Dot Records has signed Jo Stafford to a long-term exclusive recording pact, it was announced by Randy Wood, the label's president.

Several albums are already in the planning stage with arranging and conducting to be performed by the lark's husband, Paul Weston. In recent years she has appeared on the Reprise and Capitol labels.

Name Change

NEW YORK—The Five Empressions, who have been garnering some spins with their Freeport bow of "Little Miss Sad," will heretofore be known as the Five Empees. Change of name was announced last by the label's parent firm, the Buddy Brown Co.

Brook Benton's Brother Dies

NEW YORK—Alfred Peay, brother of singer Brook Benton, died here last week (4) of a cerebral hemorrhage at the age of 36. He is survived by his widow and three children.

Walden Signs Sam & Dave

MACON, GA.—Exclusive Stax recording artists Sam & Dave, of Miami, Fla., were signed Aug. 2 to a long term management contract by Phil Walden of Macon, Ga. The duo, with a new single due in the next few weeks, have joined a roster that includes Otis Redding, Jimmy Hughes, Billy Young, the Dellacardos and Arthur Conley.

SIMS STEPS IN—Steve Lawrence (left) and manager Ken Greengrass (right) congratulate Lester Sims as he joins their GLG production firm. Sims, with 15 years as general professional manager with Big 3 behind him, will be general manager of GLG's music publishing interests. The pubbery deals with every market product from rock 'n' roll tunes to standard quality ballads and is also involved with Broadway scores, television works and recordings.

- | | |
|--|--|
| SUCH AN EASY QUESTION | RCA VICTOR |
| ELVIS PRESLEY | Valley Publshers, Inc. |
| CRYING IN THE CHAPEL | RCA VICTOR |
| ELVIS PRESLEY | Elvis Presley Music, Inc. |
| I CAN'T BELIEVE IT | MGM |
| THE ANIMALS | SLAMINA MUSIC, INC. |
| (REMEMBER ME) I'M THE ONE WHO LOVES YOU | REPRISE |
| DEAN MARTIN | Hill & Range Songs, Inc. |
| IT FEELS SO RIGHT | RCA VICTOR |
| ELVIS PRESLEY | Gladys Music, Inc. |
| NO ONE | DECCA |
| BRENDA LEE | EFSEE Music, Inc./Hill & Range Songs, Inc. |
| CATCH THE BOUQUET | COLUMBIA |
| DORIS DAY | Ross Jungnickel, Inc. |
| I'M LOSING YOU | COLUMBIA |
| ARETHA FRANKLIN | Valley Publshers, Inc. |
| SUMMERTIME GIRL | RED BIRD |
| THE TRADE WINDS | Bigtop Records, Inc. |
| JUST DANCE ON BY | COLUMBIA |
| EYDIE GORME | Valley Publshers, Inc. |
| MY CAROUSEL | COLUMBIA |
| ANDY WILLIAMS | Noma Music, Inc. |
| TRAVELIN' LIGHT | MGM |
| HERMAN'S HERMITS | Alamo Music, Inc. |
| FARE THEE WELL | COLUMBIA |
| CHAD AND JEREMY | Chad and Jeremy Music, Inc./Noma Music, Inc. |
| THE THRILL OF LOVING YOU | WARNER BROS. |
| VIC DAMONE | Blen Music, Inc./Tiparfillo Music, Inc. |
| THE ABERBACH GROUP | Eleventh Floor Music, Inc. |
| 1619 Broadway, New York, N. Y. | |

The **Jagiello** SOUND IS COMING TO TOWN!

MILLS MUSIC Publishing
Million-Sellers
MILLIONS OF ROSES
 STEVE LAWRENCE (Columbia)
 JAMES DARREN (Warner Bros.)
 Happy-Go-Lucky Hit!!
"HAPPINESS IS"
 Ray Conniff and The Singers (Columbia)
MILLS MUSIC, INC.

GARNET MIMMS
"THAT GOES TO SHOW YOU"
 UA 887
 on the one to watch
UNITED ARTISTS RECORDS

The MGM Recording Miracle You Must Hear to Believe!

Hank Williams and Hank Williams, Jr. Singing together for the first time!

the startling realism of

HANK WILLIAMS, SR. & HANK WILLIAMS, JR.

singing together in a recording miracle



Read the exciting story of this recording miracle on the inside of this album

E/SE-4276

Only in the magical world of records could an event like this occur. Hank Williams, Jr. sings across the years with his father on some of the famed star's biggest hits, among them, *Honky Tonk Blues*, *I Won't Be Home No More*, and *Lovesick Blues*. MGM Records is a division of Metro-Goldwyn-Mayer, Inc.

Mercury Retains PR Services Of Kimberly-Dormann

NEW YORK—Irving B. Green, president of Mercury Records, last week announced that the company has retained The Kimberly-Dormann Corporation to handle corporate public relations and supplement the activities of the diskery's internal publicity staff.

Green emphasized that the representation of the new PR counsel will extend to artists and activities of all nine labels within the Mercury structure. These include: Mercury, Philips, Smash, Fontana, Wing, Cumberland, Limelight, Emarcy and Blue Rock.

Assisting label PR director John Sippel, and coordinating press activity with K-D from the New York offices will be Charlotte Gilbert, classical; Martin Hoffman, pop; and Myrna Greenfield, jazz.

Handleman 1st Qtr Gains

(Continued from page 168)

Florida market. He said a new record distribution center has been opened at 3979 North West 24th St., Miami. In addition, he said the company's Dallas facilities are being expanded and a new building has been leased in Dallas, in addition to present space, for record distribution. The new plant is at 8005 Sovereign Row in Dallas.

The corporation recently reported a record high in sales and earnings for the year ended April 30, 1965. Sales reached \$34,932,453 up 24 per cent over \$28,259,240 last year and earnings climbed 39 per cent to \$1,516,528 or \$1.51 per share from \$1,088,487 or \$1.09 the year before. During the past year, Handleman increased the quarterly, common stock, cash dividend to 20¢ from 17¢ per share.

With offices in both New York and Chicago, Kimberly-Dormann long has been active in the public relations field with extensive emphasis in the entertainment industry as well as with corporate and industrial clients. In addition to corporate and general publicity they will, from time to time, undertake special project assignments for the firm.

Epic Secures Hot Davey Daye Deck

NEW YORK—Epic Records has acquired the national distribution rights of Davey Day's single, "South Side Pittsburgh, Pennsylvania" b/w "Little Polish Boy." The record was released in the Pittsburgh area a few weeks ago, and, according to the label, became an immediate local hit.

The **Jagiello** SOUND IS COMING TO TOWN!



SURE SHOTS

The Cash Box "Sure Shots" highlight records which reports from retail dealers throughout the nation indicate are already beginning to sell quantity or else give every indication of doing so.

- WE GOTTA GET OUT OF THIS PLACE**
ANIMALS MGM 13382
- ONLY THOSE IN LOVE**
BABY WASHINGTON Sue 129
- TICKLE ME (EP)**
ELVIS PRESLEY RCA Victor 4383
- EVE OF DESTRUCTION**
BARRY McGUIRE Dunhill 4009
- WHO'LL BE THE NEXT IN LINE**
KINKS Reprise 0366
- MOONLIGHT AND ROSES**
VIC DANA Dolton 309
- ACTION**
FREDDIE CANNON Warner Bros. 5645
- IT'S A MAN DOWN THERE**
G. L. CROCKETT Four Bros. 445
- DANGER HEARTBREAK DEAD AHEAD**
MARVELETTES Tamla 54120
- GIVE ALL YOUR LOVE TO ME**
GERRY AND PACEMAKERS Laurie 3313

Jensen Survey Shows Disk Collecting Top Hobby

NEW YORK—A recently-concluded survey by Jensen Industries indicates that collecting records is the number one hobby of today's teenagers. The kids also play records more than any other single age group. Collecting and playing records ranked far ahead of such other teenage hobbies as card playing, photography, stamp and coin collecting and movie-TV magazines.

Estimates are that teenagers spend 40 cents out of every dollar spent for records in the U. S. They also account for 80 per cent of the sales of 3,500,000 portable phonographs annually.

The teenage influence on records is reflected in statistics showing that less than 20 per cent of all records sold are in the classical field, according to the survey.

Mills Names McKinven Veep Of Marketing

NEW YORK—John A. McKinven has been named vice-president of marketing and promotion of Mills Music, it was announced last week by Richard L. Rosenthal's the firm's president.

The addition in staff is another step in a continuing program to tap the wealth of material in the Mills catalog of classical and popular music, according to Rosenthal, who is also president of Utilities & Industries, which bought the pubbery last year.

He will report to Warren Ling, vice-president and general manager of the firm.

HERE WE ARE!

PAUL REVERE and THE RAIDERS



stars of



Brand new release:

"STEPPIN' OUT"

Also Starring on ABC's

"Where The Action Is"

A Dick Clark Production

PAUL REVERE ASSOCIATES:

Management:
Roger Hart
6290 Sunset Blvd.
Suite 414
Hollywood
HO 4-5161

Publicity:
Derek Taylor
9000 Sunset Blvd.
Suite 407
Hollywood
CR 8-1911

Booking:
Pat Mason
Box 286
Seaside, Oregon
503-RE-8-7512



PRICE PAID A TRIBUTE—Morrie Price, who left New York last week to manage MGM Records' new distributors branch in Chicago, was given a surprise luncheon at Rosoff's Restaurant and was presented with a special "Great Guy" award plaque signed by his fellow staff members. Shown at the gathering are: (first row, left to right) Gene Moretti, Sol Handwerger, Val Valentin, Tom White, Mort Nasatir, Morrie Price, Arnold Maxin, Ed Barsky, Irv Stimler, Dave Seidman, and Irv Trencher. The top row shows: Jim Vienneau, Jack Maher, Sid Dicker, Art Denish, Sid Love, Sol Greenberg, Jim Frey, Al Lewis, and George Figler.

Thanks,
Jockeys
for the
recognition

FRANKIE RANDALL

Voted

**MOST PROMISING
NEW
AMERICAN
MALE
VOCALIST**

(Cash Box Disk Jockey Poll—1965)

current single

**“YELLOW HAURED
WOMAN”**

b/w

“THE ART OF LOVE”

RCA Victor #8587



latest album

Starring in the soundtrack album

“WILD ON THE BEACH”

RCA Victor LPM/LSP-3441

RCA VICTOR

 The most trusted name in sound 

Personal Management
LEONARD S. PONCHER
VARIETY & MUSIC
1800 N. Argyle Ave.
Hollywood, Calif.
(213) HO-5-5101



WORLD WIDE!

ACUFF-ROSE PUBLICATIONS, INC.

2510 FRANKLIN ROAD
NASHVILLE, TENNESSEE 37204

ACUFF-ROSE PUBLICATIONS, PTY. LTD.

P.O. Box 513-J, Melbourne, Australia
(Australia and New Zealand)

EDITIONS ACUFF-ROSE BENELUX

13 Modeleine, Brussels, Belgium
(Holland, Republic of Congo and Luxembourg)

EDITORA BRASILEIRA DE

MUSICA ACUFF-ROSE, S. A.

Rua Quintino Bocaiuva No. 22, Sao Paulo, Brazil

ACUFF-ROSE SCANDI

247 Vesterport, Copenhagen V., Denmark
Norway, Sweden, Denmark, Finland and Iceland

ACUFF-ROSE MUSIC, LTD.

15 St. George Street, London W.1, England
South Africa, British Isles, Gire, Poland,
Czechoslovakia, Hungary and Jugoslavia

EDITIONS ACUFF-ROSE FRANCE

28 Boulevard Poissonniere, Paris, France
(France, Monaco, Andorra and such other
territories where S.A.C.E.M. collects public
performance fees directly from users.)

ACUFF-ROSE MUSIKVERLAGE

K. G.

Am Biederstein 7, Munich 23, Germany
(Germany and Austria)

EDIZIONI ACUFF-ROSE S. R. L.

Galleria Del Corso 4, Milan, Italy

ACUFF-ROSE FAR EAST, INC.

2510 Franklin Road, Nashville, Tennessee 37204
(Japan, Philippines and South East Asia)

ACUFF-ROSE VERLAG A.G.

Baarenstrasse 334, Postbox, 377
Zurich, Switzerland

EDITORIAL JULIO KORN

Morron 5000, Carrizal Aires, Argentina
(Argentina, Uruguay & Chile)

MORRO MUSIC CORP.

250 West 57th Street, New York, N. Y. 10019
(Mexico, Colombia, Venezuela and Ecuador)

EDICIONES HISPAVOX, S. A.

Cuesta Sto. Domingo 11
Madrid, Spain
(Spain and Portugal)

HICKORY RECORDS, INC.

2510 FRANKLIN ROAD
NASHVILLE, TENNESSEE 37204

AUSTRALIAN RECORD COMPANY, LTD.

11-19 Hargrave Street
East Sydney, N. S. W.
Australia

QUALITY RECORDS, LTD.

380 Birchmount Road
Scarborough, Ontario
Canada

MORKS MUSIKFORLAG

247 Vesterport, Copenhagen V., Denmark
(Scandinavia, Norway, Sweden, Denmark,
Finland and Iceland)

PYE RECORDS, LTD.

A. T. V. House, Gt. Cumberland Place
London W.1., England
(Ireland and British Isle)

ELECTRIC & MUSICAL INDUSTRIES, LTD.

Blyth Road, Hayes, Middlesex, England
(New Zealand)

EDITIONS ACUFF-ROSE FRANCE

28 Boulevard Poissonniere, Paris 9, France

CBS SCHALLPLATTEN GMBH

6000 Frankfurt/Main
Palmengartenstrasse 4, Germany
(Germany, Switzerland and Austria)

ARTONE GRAMOPHONE N. V.

Kruisstraat 8-10, Haarlem, Holland
(Holland, Belgium, Indonesia and Luxembourg)

DISCHI RICORDI S.P.A.

Via Biancamano 2, Milan, Italy

GALLO (AFRICA), LTD.

161 President Street, Johannesburg, South Africa
(Union of South Africa, Central Africa
Federation, S. W. Africa, Uganda, Kenya,
Tanganjika, Canga, Mozambique and Angola)

ACUFF-ROSE ARTISTS CORPORATION

2508-B FRANKLIN ROAD
NASHVILLE, TENNESSEE 37204

ROY ACUFF

ERNEST ASHWORTH

DON ARGO

BILL CARLISLE

DEAN & MARK

DONOVAN

JIMMY ELLEDGE

BOB GALLION

DON GANT

DON GIBSON

GEORGE HAMILTON IV

LARRY HENLEY

KRIS JENSEN

TOM JONES

GENE KENNEDY

WILMA LEE & STONEY COOPER

MIA LEWIS

BOBBY LORD

BOB LUMAN

JOE MELSON

BARBARA MILLS

THE NEWBEATS

ROY ORBISON

TEX RITTER

LONNIE "POP" WILSON



ANNUAL

World Wide

INTERNATIONAL SECTION

DIRECTORY

1965-1966

23rd Anniversary Edition



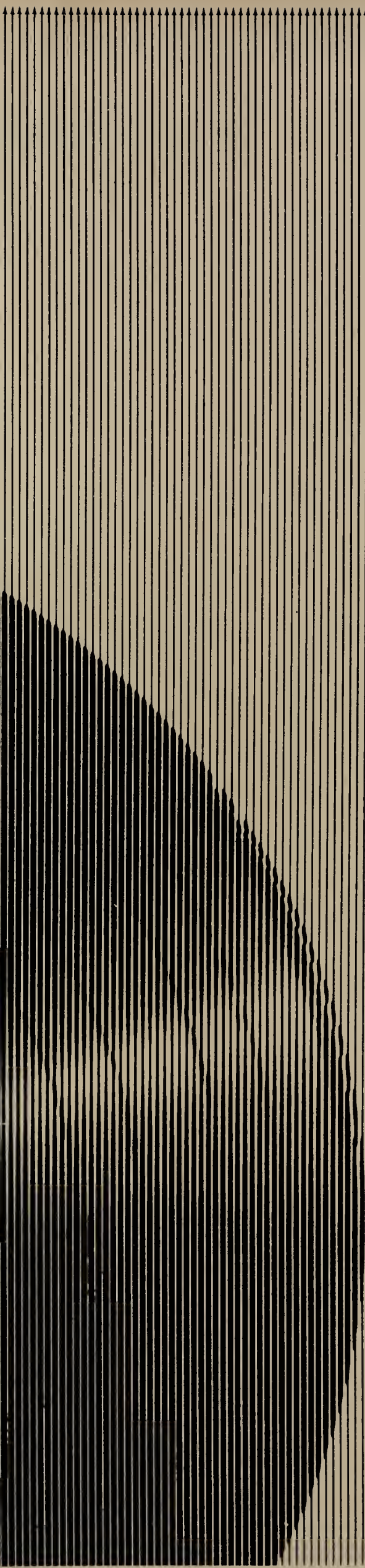

It's been a CBS Records year.

The word is spectacular for the sales, growth and chart-rated hits achieved by CBS Records during the past year.

The CBS Records list of accomplishments is unparalleled in the industry.

And the stunning success of the last twelve months is merely a starter.

The future promises even greater and more exciting gains for CBS Records and its major subsidiaries and affiliates throughout the world.

CBS Records/Entertaining the Entire World

Argentina—Discos CBS, S. A./Australia—Australian Record Company Limited/Austria—Amadeo Osterreichische Schallplatten A.G./Belgium—Disques CBS Fonoplaten/Bolivia—"Discolandia" Dueri & Cia. Ltda./Brazil—Discos CBS, S. A./Canada—Columbia Records of Canada Ltd./Central America—Industria de Discos Centroamericana Ltda./Chile—Goluboff Industrias Fonograficas S. A./Colombia—Discos CBS/Denmark—Nordisk Polyphon Aktieselskab/Ecuador—Emporio Musical S. A./England—CBS Records Limited/Finland—Music Fazer/France—ARTECO/Germany—CBS Schallplatten GmbH/Greece—Columbia Graphophone Company of Greece, Ltd./Hong Kong—Colonial Trading Company/Israel—CBS Records (Israel) Ltd./Italy—Dischi Ricordi s. p. a./Jamaica—West Indies Records Ltd./Japan—Nippon Columbia Company, Limited/Malaysia—Hup Hup Limited/Mexico—Discos CBS, S. A./The Netherlands—CBS Gramofoonplaten/New Zealand—Philips Records (N. Z.) Ltd./Norway—Norsk Phonogram A/S/Peru—Industrial Sono-Radio, S. A./The Philippines—Mareco, Inc./Portugal—Radio Triunfo, Lda./Republic of South Africa—Gramophone Record Company Limited/Spain—Hispavox, S. A./Sweden—A. B. Philips-Sonora/Switzerland—CBS Schallplatten/United States—Miami Records/Uruguay—Sondor S. A./Venezuela—La Discoteca, C. A.

England - The Past Twelve Months

REVIEW OF THE YEAR

At this time last year when the Cash Box 22nd Annual World Wide Directory went to press the British record industry was enjoying the biggest boom in its long and eventful history. Britain's transatlantic chart supremacy was at its height with 22 entries in the Cash Box American

Top 100, and 9 out of the top 15 in the British singles charts and 7 out of 10 in both the E.P. and L.P. ratings. Disks were spinning and sales were soaring as never before. In fact this time last year the spiral of the 60s was at its zenith as can be seen by the following quarter by quarter analysis issued by the Board of Trade.

PRODUCTION AND SALES

	Number of records pressed Thousands			Value of Sales £ Thousand		
	78 r.p.m.	45 r.p.m.	33 1/3rd r.p.m.	Total	Total	For Export
1963						
1st. qtr.	447	15,506	6,128	22,080	4,552	£669
2nd. qtr.	329	11,846	4,055	16,230	3,834	£566
3rd. qtr.	485	13,786	4,463	18,734	4,682	£585
4th. qtr.	585	20,204	7,621	28,410	8,697	£777
1964						
1st. qtr.	181	20,276	6,664	27,121	5,993	£766
2nd. qtr.	116	16,755	6,346	23,217	5,063	£624
3rd. qtr.	116	16,442	6,619	23,177	6,309	£713
4th. qtr.	174	19,368	8,200	27,742	8,236	£860

Although the 4th quarter of 1964 was down on 1963 the total sales for the year reached the all time high of £25,602,000, an increase of £4,000,000 on the previous year and £10,000,000 more than the total for the first year

of the decade. However, what goes up must come down and that, alas, brings us to 1965.

Again Board of Trade figures serve to illustrate month by month the comparison between the first quarter of boom year 1964 and doom year 1965.

1964						
January	101	7,864	2,758	10,723	2,223	£248
February	49	6,471	1,801	8,321	1,825	£271
March	31	5,941	2,105	8,077	1,946	£247
1965						
January	43	5,921	2,858	8,822	2,137	£237
February	51	4,707	2,030	6,788	1,834	£366
March	34	5,461	2,474	7,969	1,872	£259

The year started off with a four per cent drop in January for both home and export sales. February rallied with a three per cent increase accounted for by export sales which rose by one third. Home sales were again down by three per cent. March sales were four per cent lower than in the same month last year and again all the decrease was in home sales which fell by five per cent. Export sales were five per cent higher. Taking the first three months of 1965 as a whole home sales were four per cent lower than a year earlier although export sales increased by thirteen per cent. April figures turned out to be even worse. Sales valued at £1,543,000, were a quarter lower than in April last year. Home sales fell by over a quarter and export sales were also down by nearly one fifth. 1965 has also seen a tremendous drop in production with the axe falling heaviest on 45 r.p.m. singles. Production of 33 1/3rd L.P.s was up and in the months January to March output at this speed rose by one tenth compared with a year earlier. Again production, like sales, reached its lowest level in April and it is expected that official figures for May will be no better. A gloomy prelude to the summer holiday season when sales, even in a normal year, are expected to fall off. However, in comparing the 1965 figures with those of 1964 we are up against the most phenomenal year in record history. The comparison is necessary for the books but a much more realistic picture is obtained by comparing the first quarter of this year with the first quarter of 1963. Here again Board of Trade figures are enlightening and show a considerable increase all round both in sales and production. Therefore, although down we are far from out and have clearly benefited by the boom of yesterday. In any case after the recent tendency towards overproduction a cut in this direction will be welcomed by dealer and consumer alike provided the motives are artistic and not economic.

A multitude of reasons and explanations for the current slump have

been put forward—some more valid than others—and although it is impossible to lay the blame at any one particular door, the villains getting the most hisses seem to be pirate radio stations, taping of pop programmes, a decline in beat and the absence of a new or exciting sound, the credit squeeze, a teenage switch in spending habits, etc., etc. Although not necessarily listed in order of appearance the villain in chief does seem to be pirate radio. However, it is interesting to note that EMI carried out a nation wide sales survey amongst record dealers, 50 per cent of them in areas where pirate reception was good and 50 per cent in areas where pirate reception was bad. Sales were down in both areas but were down 20 per cent more in the first area. Some manufacturers in continental countries like Holland and Belgium where pirate reception is also good consider them a contributory factor to falling sales. The year has also seen an extension of the BBC's needle time which includes a number of pop record programmes. As to the absence of a new and exciting sound The Beatles brought musical integrity and enthusiasm into the business and a sound not violently different but refreshing—an off-shoot of rock nevertheless. In their wake came only a number of excellent groups but also a considerable amount of mediocrity. A year ago at the height of the sales bonanza everything and everyone was selling—today, as the charts testify, only the quality groups remain and quality material is becoming more and more important. The same thing happened in 1961/62 with trade jazz. The seeds sown by Acker Bilk and Kenny Ball spawned so many imitators that the sound was strangled. There are no signs that 'beat' music will suffer the same fate. The milk has been skimmed but the cream remains floating happily on the top of the transatlantic charts. As far as America is concerned the tremendous success of British artistes is evidenced by the results of the Disk Jockey survey of Most Programmed and Promising Artistes of the Year published elsewhere

in this issue. British artistes occupy the No. 1 position in no less than 6 out of the 11 categories and claim second place in four of them and figure prominently throughout. Let's have a look at the top talent of the year and the artistes scene in general.

In America British groups continue to make their presence felt in the Top 100 with The Beatles still in command. However, many of their contemporaries, household names in the States a year ago, have fallen by the wayside or have been replaced by a new wave. The most successful groups in terms of Gold and Silver Cash Box International Awards have been, besides The Beatles, The Animals, Manfred Mann, The Zombies, Herman's Hermits, Freddie and the Dreamers, Wayne Fontana, The Rolling Stones and The Searchers. In the solo field on both sides of the Atlantic the British female singer has been more successful than the male. In America the ratio was nine to six. On the distaff side success came to Cilla Black, Shirley Bassey, Millie LuLu, Julie Rogers, Sandie Shaw, Marion Faithfull, Dusty Springfield and biggest success of all Petula Clark. The opposite sex was represented by Cliff Richard, Adam Faith, Ian Whitcomb, Matt Monro, Donovan and Tom Jones.

In Britain The Beatles, The Rolling Stones and The Searchers have maintained their popularity in the beat group stakes. However, not without considerable opposition from their contemporaries both old and new. The Beatles biggest hits for EMI were with "A Hard Day's Night"; "I Feel Fine" and "Ticket To Ride" whilst The Stones took Decca to the top with "The Last Time"; "Little Red Rooster" and "It's All Over Now." The year also gave The Stones their first American No. 1 with "Satisfaction." The Searchers on Pye also had their biggest American hit to date with "Love Potion No. 9." In the home charts they scored with "When You Walk In The Room"; "Someday We're Gonna Love Again" and "Goodbye My Love." Other groups who have figured prominently in the Top Three places in the British charts are The Animals with "House of the Rising Sun" and "Don't Let Me Be Misunderstood"; Herman's Hermits "I'm Into Something Good" and "Silhouettes"; Wayne Fontana "Um, Um, Um, Um, Um" and "The Game of Love"; Manfred Mann "Do Wah Diddy Diddy" and The Hollies finally made the really big time with "I'm Alive" as did the Yardbirds with "For Your Love" and more recently "Heart Full of Soul." From Ireland Them burst on the scene with "Here Comes the Night" while another new group Unit Four Plus Two hit the jackpot with their first disk "Concrete and Clay." The Honeycombs had their moment of glory with "Have I The Right" as did Georgie Fame with "Yeh Yeh" and The Moody Blues with "Go Now." The Seekers brought a refreshing folk sound to the hit parade with two Tom Springfield compositions "I'll Never Find Another You" and "A World of our Own." The Baron Knights, a group with a satirical difference got to No. 3 with their send up of the pop scene "Call Up The Groups" and The Bachelors added "No Arms Can Ever Hold You" to their long and impeccable list of quality recordings. Last but not least in the group category Herman's Hermits made a terrific impact on both sides of the Atlantic with "You Really Got Me"; "All Day And All of the Night" and "Tired of Waiting For You." The past twelve months has seen a resurgence of the solo artiste, particularly the female of the species. Way out in front has been Petula Clark's recording of the Tony Hatch composition "Downtown" voted by American d.j.'s "The Most Programmed Single of the Year" and also won her the title of "The Most Promising Female Vocalist of the

Year" (an award not without its humorous side when one remembers that Pet has been around as a true professional since she was a child star). The title of the most promising female artiste of the year as far as Britain is concerned must surely go to yet another Pye artiste Sandie Shaw whose debut disk in the autumn of 1964—a cover of the American song "There's Always Something There To Remind Me" took her to No. 1 since when all her records have made the Top Five and her latest release "Long Live Love" gave her another chart topper. The husky voice of Marion Faithfull took her into the charts with three successive hits "As Tears Go By"; "Come And Stay With Me" (both did very well in America) and "This Little Bird." Her albums, too, have been in great demand. Yet another Pye artiste Jackie Trent topped the charts with "Where Are You Now" and on Mercury Julie Rogers landed a No. 3 with "The Wedding" as did "Twinkle with Terry." On the male side we are happy to report that Cliff Richards has not only maintained his popularity but proved himself still capable of reaching the No. 1 slot with "The Minute You're Gone" and has further enhanced his screen reputation via the box office hit "Wonderful World." The only other British male to make a No. 1 was newcomer Tom Jones with his unique recording "It's Not Unusual" which also established him in America and paved the way for his major hit "What's New Pussycat." American artistes made their biggest impact in the British charts for some considerable time. Roy Orbison had a No. 1 with "Oh Pretty Woman"; The Supremes with "Baby Love"; The Righteous Brothers with "You've Lost That Lovin' Feeling" and Elvis Presley returned to the top with "Crying In The Chapel." Other Americans to make the Top Three were Gene Pitney, P. J. Proby, Roger Miller, The Everly Brothers, The Four Seasons and the late Jim Reeves. Folk music had its biggest boost to date sparked off by the Bob Dylan releases backed by p.a.'s and TV. At the same time Britain's folkster of the year Donovan came on the scene with his own compositions bringing about a Dylan-Donovan controversy which resulted in big sales for both contenders. Many of the artistes mentioned have found their way into the charts on both sides of the Atlantic by the efforts and foresight of independent producers whose voices during the past 12 months have successfully penetrated more attentive ears than ever before.

One of the most successful of the younger indies has been Micky Most who during the year entered into an agreement whereby EMI get first refusal of his material excluding the U.S.A. where he has separate deals with CBS and MGM. Most has produced a string of hits by top artistes such as The Animals, Herman's Hermits and The Nashville Teens. The latter group are now handled by another young independent Andrew Loog Oldham who is, of course, responsible for all The Rolling Stones successes. Oldham, whose personal image is almost as well known as that of his artistes, was also responsible for the early Marion Faithfull waxings now handled by Bron Associated. Shel Talmy, American born indie producer has made his reputation via The Kinks recordings—Joe Roncoroni and Ken Jones of Marquis Enterprises have produced all The Zombies hits—Bunny Lewis of Ritz Records produced a couple of hits for The Pretty Things and FXB Productions under the guidance of Tom Springfield has been responsible for The Seekers chart entries.

On the question of R.P.M. the British record industry, as expected, confirmed its intention to resist the abolition of R.P.M. and lodged its claim for exemption with the Registrar (Continued on page 10)

WORLD WIDE MUSIC TRADE DIRECTORY

THE MOST COMPLETE DIRECTORY OF RECORD AND MUSIC
MARKETS INCLUDING NAMES OF COMPANIES AND INDIVIDUALS
IN ALL COUNTRIES THROUGHOUT THE WORLD

EXPLANATIONS

All countries are listed in alphabetic order.

All labels listed appears in alphabetic order.

As main addresses appears P. O. Box (English), Apartado (Spanish), Boite Postale (French), Postfach (German), etc., while street addresses—if known—appears within ().

Labels (domestic) refer to names of labels on which are made and released local domestic recordings. If any of the major labels appears under "domestic," it is understood that the company also is releasing whatever foreign recordings there might be available at the same label. The name of the label is not repeated under "Labels (others)."

Labels (others) refer to names of imported/foreign labels imported by the companies under which they are listed.

Remark: In some countries, mainly Central and South America and Asian countries, certain leading retailers have their own import from major European and American manufacturers, which explain why in certain cases certain labels might be listed under more than one company in each country.

All informations appearing in this Directory originates from the companies themselves, who have listed the informations published on the questionnaires they have received.

If and when a certain company is not listed in this Directory, it might depend upon the fact that the company itself has failed in returning the questionnaire which has been sent to them. If and when so is the case, Cash Box hopes to see these companies listed in next year's Directory.

ADEN

RECORD MFERS

IMPERIAL MUSIC HOUSE—Steamer Point—ADEN
Phone: 3945
Cable: CARASSELLOS ADEN
Pres.: Mr. Emm. J. Carassellos
Labels (domestic): Adenphone
Labels (others): ABC-Paramount, Artone, Audio Fidelity, Bell, Cairophone, Cameo-Parkway, Capitol, CBS, Columbia, Command, Coral, Deutsche Grammophon, Dooto, Dot, Dunia, Electrola, Fax, Gallotone, Heliador, Imperial, Liberty, Mercury, M.G.M., Cdeon, Plus One, Polydor, Pye, Rave, RCA Victor, Renown, Reprise, Ridge, Top Rank, U.A.L., Vee Jay, Walkiki, Wallis.

AFGHANISTAN

RECORD MFERS

SIEMENS AFGHANISTAN LTD.—P.O. Box 7—KABUL
(Rue Mouzino de Albuquerque 69—Luanda)
Phone: 21911, 21912, 24003
Cable: SIEMENS KABUL
Pres.: Mr. H. H. Hellhoff
Labels (others): Archiv-Produktion, Brunswick, Coral, Deutsche Grammophon, Heliador, M.G.M., Polydor, United Artists.

ANGOLA

RECORD MFERS

ADOLF ZAGEL—Caixa Postal 2755—LUANDA
(Rua Mouzino de Albuquerque 69—Luanda)
Phone: 4811
Cable: ZAGEL LUANDA
Pres.: Mr. Adolf Zagel
Labels (others): Archiv-Produktion, Deutsche Grammophon, Polydor.

ARGENTINA (See Index)

AUSTRALIA (See Index)

AUSTRIA

MUSIC PUBLISHERS

EBERLE-VERLAG—Seilergasse 12—VIENNA I
Phone: 52 27 51
Cable: WELTMUSIK VIENNA
Pres.: Mr. Joseph Hochmuth

FRIEDRICH HOFMEISTER-FIGARO VERLAG GES.
m.b.H.—Seilergasse 12—VIENNA I
Phone: 52 49 77
Cable: MUSIKFIGARO VIENNA
Directors: Mr. Stefan G. Harpner & Dr. Johann Juranek

HERMANN SCHNEIDER BÜHNEN—u. MUSIKALIEN-
VERLAGS KG—Gluckgasse 1—VIENNA I
Phone: 52 63 46
Cable: SCHNEIDERMUSIK VIENNA
Pres.: Mr. Hermann Schneider

JOSEF HOCHMUTH VERLAGSGESCHAFT—Seilergasse
12—VIENNA I
Phone: 52 27 51
Cable: WELTMUSIK VIENNA
Pres.: Mr. Josef Hochmuth

JOSEF WEINBERGER G.m.b.H.—Mahlerstrasse 11—
VIENNA I
Phone: 52 11 45
Cable: WEINJOS VIENNA
Pres.: Mr. Edmund W. Hauke

METROTON-VERLAG—Seilergasse 12—VIENNA I
Phone: 52 27 51
Cable: WELTMUSIK VIENNA
Pres.: Mr. Josef Hochmuth

SOUTHERN MUSIC G.m.b.H.—Seilergasse 12—
VIENNA I
Phone: 52 27 51
Cable: SOUTHMUSIC VIENNA
Pres.: Mr. Josef Hochmuth

WELTMUSIK EDITION INTERNATIONAL—Seilergasse
12—VIENNA I
Phone: 52 27 51
Cable: WELTMUSIK VIENNA
Pres.: Mr. Josef Hochmuth

WIEN-MELODIE, ERNST SCHEBELLA K.G.—Mahler-
strasse 11—VIENNA I
Phone: 52 11 45
Cable: WEINJOS VIENNA
Pres.: Mr. Ernst Schebella

WIENER BOHEME VERLAG—Seilergasse 12—
VIENNA I
Phone: 52 27 51
Cable: WELTMUSIK VIENNA
Pres.: Mr. Josef Hochmuth

RECORD MFERS

AMADEO OSTERREICHISCHE SCHALLPLATTEN A.G.
—Untere Donaustrasse 17—VIENNA II
Phone: 24 35 98
Cable: AMADEODISC VIENNA
Pres.: Dr. Heinrich Haerdil
Labels (domestic): Amadeo
Labels (others): Artone, Bärenreiter, Cadence, CBS, Christiana, Christophorus, Erato, Funckler, Palette, Piccadilly, Pye, Roulette, Tivoli, Valois.

ARIOLA SCHALLPLATTEN G.m.b.H.—Rosenturm-
strasse 5-9—VIENNA I
Phone: 63 55 97, 63 55 98
Telex: 3271
Pres.: Mr. Egmont Lütftner
Labels (domestic): Ariola, Athena, Baccarola, Eurodisc
Labels (others): Bel-Air, Cameo-Parkway, Colpix, Cetra, Fonit, Kapp, Laurie, Reprise, Starday, Time.

CENTROCORD SCHALLPLATTENVERTRIEBS-GES.
m.b.H.—Johannesgasse 4—VIENNA I
Phone: 52 99 55
Cable: CENTROCORD VIENNA
Director: Mr. Helmut Bischof
Labels (others): Contrepoint, Durium, Elite Special, Osea, Pop, Recordi, Sonet, Storyville, Tempo, Triola, Vogue.

MUSICA SCHALLPLATTEN VERTRIEB G.m.b.H.—
Neustiftgasse 3—VIENNA VII
Phone: 44 76 86
Cable: MUSICA VIENNA
Gen. Mgr.: Mr. Rudolf Friedman
Publicity: Mr. Franz Hochner
Labels (others): Argo, Barclay, Bel Air, Carina, Decca Festival, Linda, London, L'Oiseau-Lye, RCA Victor, Seeco, Telefunken, Véga, Warner Bros.

OESTERREICHISCHE COLUMBIA GRAPHOPHON
G.m.b.H.—Postfach 95—VIENNA I
(Fürichgasse 2—Vienna II)
Phone: 52 88 09
Cable: COLPHO VIENNA
Pres.: Mr. J.-Cl. Reymond
Labels (others): Angel, Capitol, Columbia, Concert-Classic, Electrola, Ember, Encore, English by Radio, Epic, Gloria, His Master's Voice, Imperial, Liberty, Magic Notes, Monitor, Musica Sacra, Odeon, Parlophon (el), Pathé, Regal, Stateside, Supraphon, 20th Century Fox.

OTTO G. PREISER & CO.—Fischerstiege 9—VIENNA I
Phone: 63 62 28, 63 18 53
Telex: (07) 4432
Cable: PREISERRECORDS VIENNA
Pres.: Mr. Otto G. Preiser
Labels (domestic): Die Prominente Stimme, Favorit, Kabarett aus Wien, Lebendiges Wort, Unikum.
Labels (others): Calig, Eterna, Experience, Fidelity, Harmonia Mundi, Heritage, Horoskop, Lyricord, Parliament, Saga, Scala, Somerset, Vox.

POLYPHON SCHALLPLATTEN G.m.b.H.—Potsfah
265—VIENNA 56
(Mariahilferstrasse 127—Vienna VII)
Phone: 56 35 06
Cable: POLYPHON VIENNA
Pres.: Mr. Gerhard Gebhardt
Labels (domestic): Philips, Polydor
Labels (others): ABC-Paramount, Archiv-Produktion, Audio Fidelity, Brunswick, Contemporary, Coral, Deutsche Grammophon, Fontana, Good Time Jazz, Heliador, Jazzland, Literarische Archiv, Mercury, M.G.M., Riverside, United Artists, Vee Jay, Verve, Westminster, World Pacific Jazz.

SYMPHONIA—WIENER SYMPHONIKER TONAUFNAHME
G.m.b.H.—Lothringerstrasse 20—Konzertthaus
—VIENNA III
(Vienna Symphony Orchestra Recording Corp.)
Phone: 72 44 48, 57 72 41
Cable: SYMPHONIA VIENNA
Pres.: Mr. Herbert Wegricht
Produces tape recordings for commercial use by record mfrs with the Vienna Symphony Orchestra.

BAHAMAS

RECORD MFERS

BAHAMA RECORDS, LTD.—P.O. Box 942—NASSAU
(c/o Carib Shop—George Street—Nassau)
Phone: 2201
Pres.: Mr. T. R. Pyfrom
Labels (domestic): Bahama

BAHAMIAN RHYTHMS, LTD.—P.O. Box 942—NAS-
SAU
(c/o Carib Shop—George Street—Nassau)
Phone: 2201
Pres.: Mr. T. R. Pyfrom
Labels (domestic): Bahamian Rhythms

CARIBBEAN FOLK MUSIC, LTD.—P.O. Box 174—
NASSAU
Phone: 94370, 94371
Cable: TROPICAL NASSAU
Pres.: Mr. Tom Y. Jacobs
Labels (domestic): Carib

BAHREIN

RECORD MFERS

AMBASSADOR STORES—P.O. Box 237—MANAMA
Phone: 3513
Cable: AMBASSADOR BAHREIN
Pres.: Mr. Victor Murad
Labels (others): Audio Fidelity, Brunswick, Capitol, CBS, Command, Deutsche Grammophon, Fontana, Golden Guinea, Mercury, M.G.M., Philips, Polydor, Pye, RCA Victor, United Artists, Verve.

THE NATIONAL MUSIC HOUSE—P.O. Box 174—
MANAMA
(Shaikh Abdulla Road—Manama)
Phone: 4819
Cable: KHAWRAN BAHREIN
Pres.: Mr. A. Hussain Mahmood Sa'aty
Labels (domestic): Al-Nasr, Alshark, Arabphone
Labels (others): Columbia, His Master's Voice, Parlophone

BERMUDA

RECORD MFERS

EDMAR RECORDS—Harrington Hundreds—HAMIL-
TON
Cable: EDMAR RECORDS BERMUDA
Pres.: Mr. Edward De Mello
Labels (domestic): Duane, Edmar

MASTERS LTD.—Front Street —HAMILTON
Phone: 2-3000
Cable: MASTAND HAMILTON
Pres.: Mr. W. H. Freisenbruch
Labels (domestic): Mastertone

BOLIVIA

RECORD MFERS

JOHANSSON & CIA., S.A.—Casilla 678—LA PAZ
(Calle Mercado, Esquina Socabaya, Avenida Santa Cruz—La Paz)
Phone: 5700, 8700, 9846, 10646
Cable: JOHANSSON LAPAZ
Pres.: Mr. Einar Johansson
Representing Deutsche Grammophon G.m.b.H. (Hamburg) in Bolivia

PHILIPS SUDAMERICANA S.A.—Cajón Postal 2964
—LA PAZ
(Avenida Santa Cruz 1365—5° piso.—La Paz)
Phone: 5664, 8029, 5270

Cable: PHILIPS LAPAZ
Mgr.: Mr. W. Carp
Labels (others): ABC-Paramount, Columbia (Argentina), Decca, Deutsche Grammophon, Fontana, Mercury, Philips, Polydor, Roulette, Sinter (Brazil), Westminster.

BULGARIA

EXPORT & IMPORT

RAZNOIZNOS—Boite Postale 615—SOFIA
(1, rue Tzar Assen—Sofia)
Phone: 8-02-11/18
Cable: RAZNOIZNOS SOFIA
Man. Dir.: Mr. D. Gorostanov
Only organization to be contacted in questions of export or import of ready-made cultural goods (records and sheet music editions).

MUSIC PUBLISHER

NAOUKA I ISKOUSTVO—Boulevard Rouski 6—
SOFIA
Phone: 7-57-01
Pres.: Mr. Tsonjou Botev

RECORD MFERS

BALKANTON—2 rue Hajdoushka Poljana—SOFIA
Phone: 5-24-45, 5-22-34, 5-31-96
Cable: BALKANTON SOFIA
Pres.: Mr. Encho Dimitrov
Labels (domestic) Balkanton

BURMA

RECORD MFERS

NEONLITE MANUFACTURING & TRADING CO., LTD.
—P.O. Box 1023—RANGOON
(59, 38th Street—Rangoon)
Phone: 14340, 15770
Cable: NEONLITE RANGOON
Pres.: Mr. Harbans Singh
Labels (domestic): Aung Tha Bye, Bay Lu Wa, HRC, Tet Toe, Toe Na Ya.

THAN INDUSTRIES—P.O. Box 971—RANGOON
(17/19) Shwedagon Pagoda Road—Rangoon)
Phone: 15787, 30490
Cable: THANCORP RANGOON
Pres.: U Aung Than
Labels (domestic): Mount Everest, Toe Naing

CEYLON

RECORD MFERS

CARGILLS (CEYLON) LTD.—P.O. Box 23—COLOM-
BO 1
(York Street—Colombo 1)
Phone: 79331
Cable: CARGILLS COLOMBO
Pres.: Mr. J. L. M. Fernando
Labels (others): Angel, Audio Fidelity, Capitol, Columbia, His Master's Voice, Mercury, MGM, Parlophone, Pathé.

MILLERS LTD.—P.O. Box 100—COLOMBO 1
(York Street—Colombo 1)
Phone: 79251
Cable: MILLERS COLOMBO
Pres.: Mr. Cyril Gardiner
Labels (domestic): Columbia (Sinhalese)
Labels (others): Fontana, Nixa, Philips, Pye, RCA-Italiana, Vanguard.

CHILE

COLLECTING SOCIETY

DEPARTAMENTO DEL PEQUEÑO DERECHO DE
AUTOR
DE LA UNIVERSIDAD DE CHILE—Apartado 1072—
SANTIAGO DE CHILE
(San Antonio 427—Santiago De Chile)
Phone: 34914, 36375
Pres.: Mr. Diego Barros Ortiz

MUSIC PUBLISHERS

EDICIONES MUSICALES FERMATA—Los Alpes 916—
SANTIAGO DE CHILE
Pres.: Mr. Enrique Lebendiger

RECORD MFERS

CORPORACION DE RADIO DE CHILE S.A.—Casilla
1407—SANTIAGO DE CHILE
(Vicuña Mackenna 3333—Santiago de Chile)
Phone: 50081
Cable: VICTOR SANTIAGO CHILE
Pres.: Mr. Julio Del Rio Bretignere
Labels (domestic): CRC, Demon, RCA Victor
Labels (other): Artone, Atlantic, Cetra, Decca, Disc Jockey, Discophiles Français, Dot, Ducretet-Thomson, Fermata, Fonit, Hispavox, Music Hall, Telefunken, Tropicana.

(Continued on page 22)

EMI ... record

... press

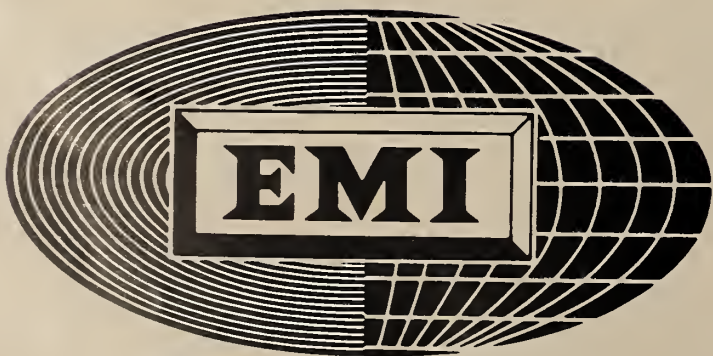
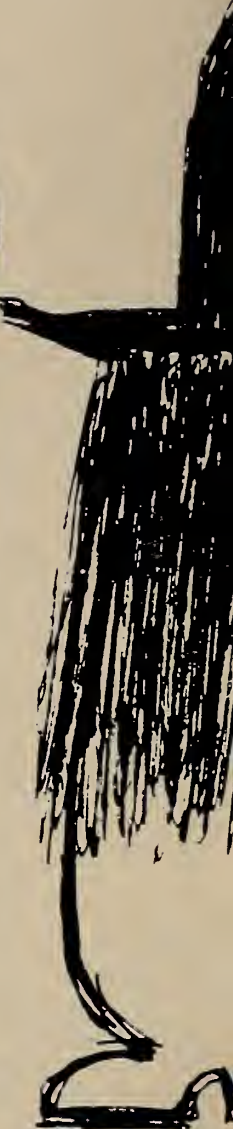

THE GREATEST RECORDING ORGANISATION

... market
records
all over
the
world

... promote

... import

... export

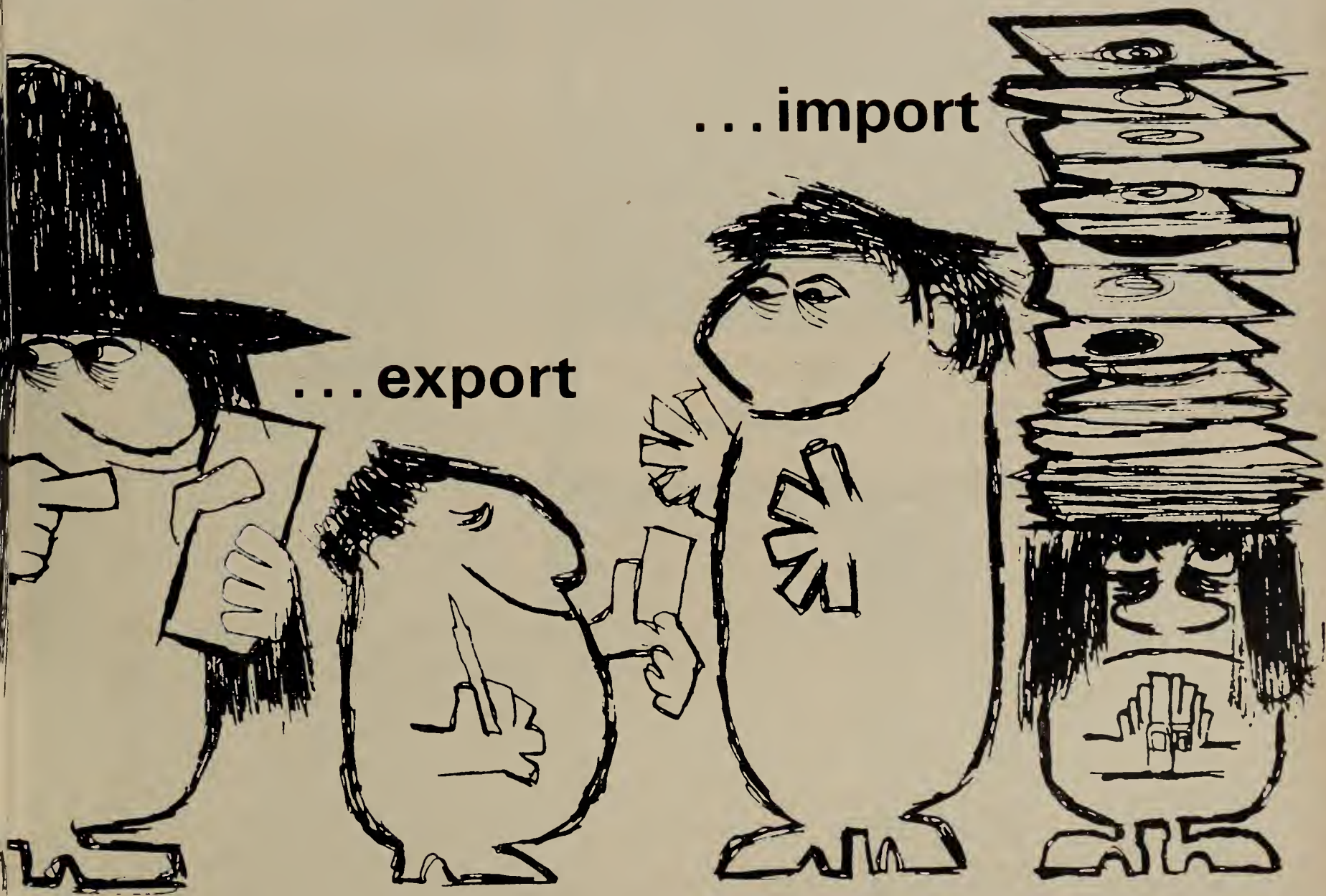

... IN THE WORLD / EMI LIMITED · HAYES · MIDDLESEX · ENGLAND

PIX and CLIPS

A random selection from hundreds of news items about artists and personalities on the EMI international scene



ROYAL VISIT TO HAYES Sir Joseph Lockwood, Chairman of E.M.I. Ltd., greets Princess Margaret and her husband, the Earl of Snowdon, when they visited E.M.I.'s headquarters at Hayes, in Middlesex, earlier this year. The Princess and Lord Snowdon toured E.M.I.'s Electronics and Research Laboratories, the Record Factory and the Company's Museum.



CALLAS A PARIS INTERNATIONAL operatic star Maria Callas, who has recorded for E.M.I. such best-selling albums as Bizet's "Carmen" and Puccini's "Tosca", is pictured here in the Paris recording studios of Pathe-Marconi, E.M.I.'s associate company in France.

The Koran on Records

Mrs. Devan, E.M.I. Records' A and R Manager for Malaysia, presenting a set of recent E.M.I. recordings from the Koran to Tunku Abdul Rahman, Prime Minister of Malaysia. The recordings were made by Ustad: Ishmail Haji Hashini, winner of the Malaysian National Koran Reading Competition for the past two years. With Mrs. Devan and the Prime Minister is Mr. J. B. Stevenson, Deputy Managing Director (Technical), of E.M.I. Records.

SIR JOSEPH LOCKWOOD, Chairman of E.M.I. Ltd., presents SIR MALCOLM SARGENT with an album of LPs from his repertoire recorded on the His Master's Voice and Columbia labels. The occasion was a luncheon given by E.M.I. at the Savoy Hotel, in London, to celebrate Sir Malcolm's 70th birthday. Among the guests was Prince Philip.



THE GREATEST RECORDING ORGANISATION IN THE WORLD

E.M.I. LIMITED · HAYES · MIDDLESEX · ENGLAND





French maestro **FRANK POURCEL**; a Pathe Marconi artiste, is presented with his **TEN-MILLIONTH RECORD** at a reception in Paris to mark this tremendous sales achievement. Proudly looking on is Frank's daughter, while the all-important record is held by top French singer Enrico Macias. Extreme right is M. Rouzies, vice-president of Pathe Marconi, an associate E.M.I. company.



SONG FESTIVAL WINNER

His Master's Voice recording artiste Kenny Lynch with the trophy he won at the first-ever British Song Festival held at Brighton, English South coast holiday resort. Kenny wrote the winning song, "I'll stay by you", with Hal Shaper—and sang it himself in the Festival.



BEACH BOYS IN BRITAIN The Beach Boys—Carl, Brian and Dennis Wilson, Mike Love and Al Jardine photographed when visiting Great Britain for personal appearances. Top disc stars on both sides of the Atlantic, they record for Capitol, E.M.I.'s associate company in the United States.

The Beatles with Miss Rimiko Hoshika, Chief Editress of Japan's "Music Life" magazine after she had presented them with two plaques (awarded by "Music Life") for Top Artists of the Year and Top Title ("I want to hold your hand"). The presentation took place at E.M.I.'s St. Johns Wood, London, recording studios.



The celebrated German-born baritone **DIETRICH FISCHER-DIESKAU**, who has been featured on several outstanding E.M.I. albums, is seen here recording for E.M.I. at the Kingsway Hall, in London.



VOCE DEL CLIFF

Recording—in Italian—at E.M.I.'s Lisbon, Portugal, studios is British song star Cliff Richard. Cliff gets a helping hand with the Italian language as John Lee (left), head of the A & R Division of Voce del Padrone Columbia-Marconiphone, E.M.I.'s associate company in Italy, looks on.



England — The Past Twelve Months

(Continued from page 4)

trar of Restrictive Trading Agreements. The result which rests with the special tribunal is not expected for several months. Meantime the industry continues to maintain price structure. Several of Britain's smaller but active independent record companies have acquired wider distribution via EMI depots during the year including Ember, Delyse, Island, R & B and Waverley.

Stereo sales have increased and the L.P. field account for approximately 20 per cent of total sales. Not as high as in some continental countries but it is estimated that in this country the number of machines fitted with mono only stylus represents around 70 per cent of the record producing equipment in use. Therefore, at the moment, it seems unlikely that the U.K. could or would follow the German practice (planned also by Denmark) of producing only stereo L.Ps. The E.P. has assumed greater importance in recent months and disks at this speed by artistes such as The Beatles, The Rolling Stones and Manfred Mann have been selling in quantities reserved usually for singles. Regarding the future of the E.P. manufacturers and dealers beg to differ. Some consider it harmful to L.P. sales particularly when tracks are taken from album sellers others favour the E.P. provided it is not used as an excuse for off-loading spare album tracks and repeats of singles already issued.

Amongst one of the less successful events of the year must be numbered the 1965 meeting of the Gramophone Record Retailers Association. Once again the affair was supported by a mere 40 or 50 dealers out of a membership numbering almost 2000. Dissension within the ranks of the Association at Committee level did little to help the cause and resulted in the resignation of six outgoing executive members. The G.R.R.A. and record retailers need each other and it is hoped that the newly formed executive under the leadership of Reg Reed (President) with Harry Tipple as Secretary will, with the support of their members, adopt a united-we-stand-divided-we-fall policy at a time when the wind of change is blowing through the industry.

RECORD COMPANIES

For EMI, as the company's annual report confirmed, 1964 was the best year in the group's history with sales up by 12 per cent and the profits before tax of £9,104,000—an increase of 80 per cent on the previous year. The record division's contribution to the group was considerable and the promotion of British artistes which has built up over the years paid off handsomely. Besides The Beatles MBE (one of whose American releases sold 3.5 million copies in under three months whilst another sold 1 million in one week—both staying at No. 1 in the Top 100 for 12 weeks) many other EMI artistes helped the company's sales including Cliff Richard, The Shadows, Cilla Black, Freddie and the Dreamers, Herman's Hermits, The Dave Clark Five, Gerry and the Pacemakers, Billy J. Kramer etc. etc. During the year EMI have renewed contracts with American labels Laurie, Epic and Verve and extended their contract with United Artists. A major event of the EMI year was the launching of Tamla Motown in the U.K. on its own label previously issued by EMI on Stateside. The launching in March this year was attended by top executives of the Tamla Motown label and artistes including The Supremes, Martha and the Vandellas, The Miracles, The Temptations and Earl Van Dyke. The Tamla Motown package also made an extensive 24-day tour of Britain. Organisational changes included the marshalling of the company into four separate divisions—A & R, Produc-

tion, Commercial & Financial and the formation of West One Entertainment Ltd. to handle their agency, personal management and exploitation activities. Chairman Sir Joseph Lockwood told Cash Box that EMI's world record sales for the year ended June 1965 would be up on the world figure for 63 and 64. As far as the United Kingdom is concerned the percentage for the first quarter of 1965, although down on last year, is only slightly so and only in the singles field. L.P. sales have been greater than ever. Sir Joseph added that EMI classical sales in the U.S.A. were greater than those of any other company and that during the past twelve months EMI has outsold all other companies in total retail sales. EMI occupies a unique position in the world market with its own subsidiaries established in every major country of the world during the last 60 years except in Mexico where Capitol Records and EMI are now jointly opening up.

For Decca as for England and indeed the world the year 1964/65 will be forever linked with the death of Sir Winston Churchill. In November 1964 to coincide with the Statesman's 90th birthday Decca bequeathed to posterity a magnificent set of twelve L.P.s "Churchill Speaks" comprising speeches and readings from Sir Winston's works and memoirs. Two thirds of the recordings which provide 11 hours listening had never been heard before and the complete set represents more than 12 months research and construction. After the death of Sir Winston, Decca issued a two-disk set of the funeral service with tributes by General Eisenhower, Sir Robert Menzies and Harold Wilson. During the year Decca completed a deal with Atlantic Records of America to distribute their product in this country on its own label. In January they acquired the American Ava catalogue for release on the London label. The Fred Astaire catalogue was previously released here by EMI on the MGM label. In April Decca launched their third Ace series—a new low-priced label Ace of Diamonds companion to Ace of Clubs and Ace of Hearts, comprising recordings previously issued on higher priced Decca labels. Earlier this year rumours that Decca was once again the subject of a take over bid sent the shares soaring but came to nothing. Artiste wise Decca had a remarkably successful year with The Rolling Stones at the top of the roster as controversial and successful as ever. Their singles, L.Ps and E.Ps continue to sell in vast quantities. Other chart stalwarts on Decca have included The Bachelors, The Nashville Teens and Unit Four Plus Two. Two new solo artistes emerged on the label Marianne Faithfull with three-in-a-row and Tom Jones.

1964 was Philips Records best year to date with an overall increase of 17 per cent. They renewed contracts with Vanguard for a further five years and also with Caedmon. Philips, like many other companies, has taken a fall in single sales but General Manager, Leslie Gould, reports a considerable increase in the company's tape recorder sales which he attributes to wide spread taping of the non-stop air play on pirate stations, London and Caroline. In December Philips concluded a world wide agreement with Vee Jay Records of America to release their powerful catalogue of authentic r & b, and gospel material on the Fontana label. They have also had their biggest American success to date with Wayne Fontana's No. 1 hit "The Game of Love." Dusty Springfield has gone from strength to strength as a solo artiste and has realised the brilliant future we predicted for her this time last year. After her smash hits "I Just Don't Know What To Do With Myself" and the follow up "Losing You" Dusty had a sticky patch and was out of the hit parade for a while

but has now made a come back with "In The Middle of Nowhere." Her biggest American success came with "Wishin' and Hopin'" which took her to No. 4 and earned her a Cash Box Silver Award. Other artistes who have contributed to the Philips/Fontana run of hits include Millie, Julie Rogers, The Pretty Things and The Four Pennies. The biggest L.P. sellers have been by Les Swingle Singers, Frankie Vaughan and Harry Secombe. The original cast album "Pickwick" stary Secombe sold 10,000 more than any other British musical whilst the single "If I Ruled The World" notched up 250,000 and is now expected to repeat its success in America when the show opens on Broadway. Fontana have enjoyed considerable success with its Blue series and has stepped up releases to become the biggest jazz label in the country. In March Philips introduced a new low-priced "Wing" series of L.Ps ranging from pops to classics. The same month they announced that in future their products would be distributed exclusively through their own depots.

Pye Records climaxed five years of marked progress by announcing that for the year ending June 1965 record sales both single and L.Ps were going up at a time when industry sales generally were in decline. Consolidation of the company's five year build up policy or organisation and catalogue plus the nurturing of talents such as Tony Hatch and John Schroeder has resulted in items like "Downtown" and The Sounds Orchestral. During the past year Pye artistes have enjoyed greater chart success both here and in America than ever before. They had no less than six No. 1s in Britain, the most spectacular being "Downtown" which took the writer, Pye A & R Manager Tony Hatch and recording star Petula Clark to the top of the world charts. In January Pye occupied the No. 1 and 2 slots in the Cash Box American Top 100 with "Downtown" and "Love Potion No. 9" by The Searchers. Their growing prestige in the international record market has brought a renewal of the Reprise contract and the acquisition of Dot Records, Command, Redbird, Durium and Vogue and more recently Warner Brothers, previously handled by Decca plus many other important American catalogues. A major step in Pye's administration takes place this August when Jim Bailey, late of Dot Records, joins the company's International Department. Their confidence in the talents and growing importance of the independent record producer has given Pye such artistes as The Kinks, The Honeycombs, Sandie Shaw and Donovan. During the year their factory has been enlarged and distribution expanded in line with the company's increasing output. The studios are in great demand producing records not only for Pye and its associates but its competitors as well. At one time no less than 9 out of the Top 30 were produced in the Pye studio. In August this year Pye undertakes their biggest ever catalogue promotion with the introduction of Warner Brothers and the re-introduction of Reprise. Executives and artistes from both companies will visit the U.K. for this prelude to the winter season to be followed in September and October by similar campaigns for all catalogues controlled by Pye Records.

After 20 years as Britain's leading independent label Oriole this year became CBS with Morris Levy, founder and boss of Oriole as its Managing Director. The changeover began in the fall of 1964 when the CBS catalogue had to be transferred from the previous licencees Philips Records. The official CBS launching party held at the Dorchester was a major highlight of the current record year. At the time of writing Levy reports that in spite of the enormous problems involved in the transference of such a vast catalogue the inevitable teething

troubles have almost been eliminated. CBS immediately established itself in the singles E.P. and L.P. charts notably via Bob Dylan and more recently with The Byrds. Big dividends have been paid by the success of artistes such as Tony Bennett, The New Christy Minstrels, The Clancy Brothers, Robert Goulet and many others whose personal appearances have greatly enhanced their record sales. They plan to maintain a constant flow of visiting artistes and expected in the near future are Johnny Cash and Andy Williams whose own TV shows are currently being screened by the BBC. British talent already registering for CBS includes writer/artiste John Barry and Chad and Jeremy. New names are being signed to strengthen the home roster and indie producers are also getting encouragement. Distribution has been strengthened and despite the changes being contemplated by the industry CBS are confident that their nationwide coverage will not only be maintained but improved. Their export activities are being further developed for the benefit of their overseas affiliates. Looking to the future Morris Levy indicated that great emphasis will be placed on the CBS bread and butter catalogue of L.Ps and is confident that with a fair share of jam in the singles field the company looks to the future with optimistic confidence.

In the realm of spoken word recordings it is gratifying to report that for Argo Records it has been another year of satisfaction both artistically and financially. Hopes that sales for 1963/64 would be maintained in 1964/65 have been fulfilled and exceeded. Released of the burden of compiling the Shakespeare Cannon (137 L.Ps) in time for the Quarter-centenary Argo have been able to diversify their activities and devote greater production facilities to music recordings. These include four albums ranging from music by Bach and Mozart to a pop organ album "Crown Imperial" by Simon Preston, sub organist of Westminster Abbey and the most outstanding organist to arrive on the music scene of 1964/65. He will tour America in the fall. The year has also seen the emergence of St. John's College Choir of Cambridge as serious challengers to the established Kings College Choir whose L.Ps have been Argo best sellers for over a decade. Of the 70 albums scheduled in Argo's "English Poets" series 20 have been completed and released with production continuing at the rate of 6 albums a year. Top names of the British theatre who have contributed to the series include Peggy Ashcroft, Richard Johnson, Max Adrian, Alan Bates, Michael Hordern and Patrick Wymark. Another poetry series of 6 L.Ps has just been completed entitled "The Poet Speaks" containing the voices of some 30 contemporary English poets and is scheduled for transatlantic release in the Autumn in association with The British Arts Council and The Lamont Poetry Library of Harvard University.

Smaller in scope but admirable in content is the output of Jupiter Records, consistent and acknowledged specialists in the release of spoken word and childrens recordings. Their latest venture is the release of a new E.P. series "Poets Set To Jazz" featuring a host of leading singers and jazzmen.

During the year Leomark have completed their new English Bible recordings of the New Testament. The fruits of four years continuous recording, under the direction of Frederick Bradshaw, the Leomark spoken bible series comprises 31 12" L.Ps. The albums feature many top British actors including Margaret Rawlings, Dame Flora Robson, Barbara Jefford, Dame Sybil Thorndyke, Paul Rogers etc. etc. Leomark are released in the States by Word Records of Texas, in Canada by J. Lyons & Co. as well

(Continued on page 12)

THE DECCA RECORD COMPANY LIMITED

FOUNDED 1929

and its USA subsidiary

LONDON RECORDS INC.

FOUNDED 1948

ONE OF THE WORLD'S GREAT RECORD GROUPS



The Decca Record Company Limited
Decca House
Albert Embankment London S E 1

England — The Past Twelve Months

(Continued from page 10)

as by companies in several major European territories, the latest addition being Finland.

For Delyse Records who celebrated their tenth anniversary in October it has been another year of progress. A major event was the achievement of complete nationwide distribution for their product by adding EMI's facilities to their existing arrangements with Selecta. This blanket coverage has already doubled the company's turnover. Delyse, with a predominantly Welsh catalogue have extended their sights across the Irish sea and are now building up a comparable repertoire of showband, folk and choral material. Their most recent release is a 12" L.P. "In Dublin's Fair City" by The Guinness Choir. A single by The Little Dublin Singers waxed at the same time is now on release. Back to Wales—in April this year Delyse released a sequel to their 50,000 best selling album "A Nation Sings" Vol. 1. Like its predecessor, Volume 2 was recorded live in the Royal Albert Hall by a 6,000 strong choir. Within two weeks of release sales exceeded 20,000 copies. During the past twelve months the company has, for the first time, acquired material recorded abroad by other companies for release here on the Delyse and Envoy labels. They plan to extend this activity considerably in the coming year.

Transatlantic Records Ltd. report a year of remarkable progress during which they have moved to spacious new offices in the West End of London. Last August they took over production and distribution of the Danish based Storyville label and since then riding the booming interest in blues they have released 41 L.Ps and 17 E.Ps on the folk/blues/jazz label. In October Transatlantic launched their Xtra line, the first budget line (retailing at 21/—) specialising in folk and jazz. Xtra has featured over the past nine months artistes such as Pete Seeger, Woody Guthrie, Carlos Montoya, Charlie Parker, Budd Powell, Big Bill Broome, Brownie McGhee and Sonny Terry and Art Tatum. Local British folk artistes are also being introduced to the label although for local folk talent the showcase is primarily the Transatlantic label itself. Here two of Britain's top folk groups, The Ian Campbell Folk Group and The Dubliners have enjoyed further successful L.Ps and two exciting new talents Bert Jansch and Owen Hand have been launched. The Campbell group also reached the charts for several weeks with their version of Dylan's "The Times They Are Achanging." This was the first time a British independent company, without any distribution aid at all from the majors, had pierced the British Top 50. In November Transatlantic obtained the distribution rights of the Soviet MK label and added artistes such as Richter, Rostropovitch, David Oistrakh, Ashkenazy and The Bolchoi Opera Company to their roster. Agreements were concluded during the year with CNR Holland, Discobell Belgium and Deutsche Vogue for distribution of Transatlantic lines in Germany, Austria and Switzerland and Transatlantic artistes such as The Campbells, The Dubliners and Bert Jansch were licensed to companies in the U.S.A., Canada, Holland, Australia, New Zealand, Denmark and Sweden. Transatlantic also formed Heathside Music Ltd., a publishing subsidiary which has had a promising first year. Managing Director Nathan Joseph reports an increase in their turnover in 1964/1965 of 350 per cent.

For Jeff Kruger's British independent Ember Records the year has seen continued expansion and increasing interest both in Europe and the U.S.A. At home just four years after its inception the company moved into new premises in Wembley, Middlesex. Artiste wise Chad Stuart and Jeremy Clyde, besides earning dollars for the label in the United States, began to break through in their native Britain. The duo had five consecutive singles and 2 L.Ps in the American Top 100.

John (Goldfinger) Barry with his original soundtrack from the film "Zulu" and his single "From Russia With Love" also garnered sales for Ember on both sides of the Atlantic. Early this year Kruger signed a five-year agreement with Mike Stewart and Murray Deutsch of United Artists Corporation under which the Ember product gets major exposure in the U.S., Canada, Mexico and South America on the U.A. label. In Finland Kruger signed an agreement with Sandia Music for the release of Ember in that territory. In February Ember, previously distributed by Selecta and other independents increased their national distribution facilities with the addition of EMI depots. They expect 1965/66 to be a vintage year.

Polydor (DGG) subsidiary of the parent company in Hamburg, Germany, having entered the production field are steadily building a roster of British artistes and material. Several organisational changes have taken place and the company is stepping up its output particularly in the pop field. Future plans include a release programme of some 70 pop singles within the next 12 months. Internationally produced disks suitable for this market will also be issued. Recently Polydor International released a 12" L.P. "The Best of Bert Kaempfert" which included the German artiste's million seller "Wonderland by Night."

For Melodisc Records after the bluebeat boom of 1963/64 it has been a year primarily devoted to the establishment of their folk line, particularly L.Ps. In this category the label's best seller has been the Woody Guthrie Sings L.P. They also had a great success with two African albums featuring West African music by The West African Rhythm Brothers. In the r & b field they had a major success with the Neutrons "The Very Best Things In Life Are Free." Melodisc future plans include their first venture into the low-priced field with the autumn release of a series of L.Ps comprising classical, folk, jazz and r & b material retailing at 20/—.

Carlo Kramer whose Esquire and Starlite labels remain dormant formed a new company Talent Records Ltd. He also concluded an agreement with Bob Koester of America to release material from his catalogue of authentic traditional and modern jazz in this country on his own Delmark Records label.

R & B Discs, already successful with the Ska-Beat, King, R & B and Prima labels, acquired two more American catalogues, Downey of California and Buhl International for release here whether on the pop King label or on the R & B label. The year has also marked a strengthening of the company's distribution system previously distributed by Selecta they are now available through EMI depots as well.

Collector Records, specialists in folk, blues and flamenco with an annual release programme of 20/30 E.Ps and L.Ps this year introduced a new label "Range." Essentially concerned with country and western, blue grass and rhythm and blues, Range is a low priced label at present confined to E.Ps. But plans are being made to extend the Range output into the L.P. field.

Island Records further enhanced their reputation as a leading company in the field of Jamaican music with a mass of authentic ska rhythm releases imported from Jamaica. Although Island Records lost the Sue label in November they strengthened their position by licensing several other American companies including Ace Records with a roster of artistes including Otis Redding, Joe Tex, James Brown, Hughey (Piano) Smith, Elmore James and Larry Williams. The latter also cut a single and L.P. in this country. Island have also brought over a number of r & b artistes including Charles and Inez Foxx, The Soul Sisters and Donnie Elbert, for p.a.'s and TV. In January

the company formed a new label Aladdin exclusively for pop releases which is building steadily with productions by Charles Blackwell and Guy Stevens. The Surprise label also proved highly successful particularly with "Rugby Songs" which sold over 100,000 copies and entered the L.P. charts.

From Island to Ireland where Emerald Records Ltd. report by far their most successful year to date. A major achievement was the discovery of the Belfast group Them now signed to Philip Solomon Organisation and released by Decca. Emerald also had a number of their albums and singles released by various companies around the world including London Records of America, Compo of Canada, W & G of Australia and Gallo of Africa. In June they released the 2nd L.P. by The Glenfolk Four and expect in the coming months to achieve considerable success with the recordings by the Irish showbands which they will sub lease overseas. Pickwick International marked their second year's activities in the low-priced field by moving to larger premises. Boss Monty Lewis reports a considerable advance in business particularly in the first quarter of 1965. During the year Pickwick concluded a major deal with W. H. Smith & Sons (Britain's largest chain of bookshops) as a result of which the Pickwick product released here on Allegro is handled by some 450 Smiths branches including many sited on railway stations.

PUBLISHING

Over to publishing where, once again, the accent has been predominantly British richly coloured by overtones of Liverpool and Bow Bells. The world wide demand for British artistes and material manifested in 1963 and 1964 has continued unabated. In America the pro-British cult initially sparked off by the pop group invasion has spread to other fields and many of Britain's trendsetters from coiffeurs to coutouriers have crossed the Atlantic with considerable success. Just how successful British artistes and songs have been in America during the last year may be judged by the fact that exactly twice as many artists entered the Cash Box Top 100 as in previous years. Out of a total of 126 titles 76 were British compositions, again just double the number for the preceding year. Local compositions also accounted for 50 per cent of the Best Selling Sheet Music sales in Britain during the year. All this had added more power to the British publishers elbow enabling him to call a more profitable tune. However, every sliver lining has a cloud and the other side of Tin Pan Alley is not so sunny. Sheet music sales which have been in decline for several years have now dropped so low to be (except on rare occasions) almost non-existent. A major hit might sell 10,000 plus but for an average chart entry 4-5,000 would be good. A far cry from the days when a major hit would sell over 100,000 copies of sheet music. However, in recent years what the publisher with a hit has lost in low sheet sales he has gained in royalties from increased record sales. But as reported at the beginning of this review these, too, are now falling. Whereas a year ago a No. 1 might easily earn a Gold Disk (1,000,000) today the same No. 1 would have to be content with a Silver (250,000). Nevertheless there has been plenty of progressive thinking and quite a lot of action in and around the alley particularly in the field of independent recordings. More and more companies are making their own masters and, as in America, the charts are peppered with indie produced hits issued by major manufacturers who, like Canute, find themselves unable to stem the advancing tide. Thanks to the efforts of the Music Publishers' Association the first British Song Festival was born at Brighton in May this year—a welcome but unruly infant that needs a lot of wetnursing if it is to

grow into an annual event to rival San Remo. However, if the M.P.A. can profit by this year's mistakes and Brighton hoteliers improve their menus and amenities maybe the many overseas publishers and music men who supported the event can be persuaded to come again next year. Meantime let's take a look at the publishing scene in Britain over the past twelve months.

For Southern Music one of the first and most consistent publishing houses to plug British talent and material it has been another year of patriotic endeavour. The company's remarkably high percentage of chart entries have included disks by some of the biggest names in the business—The Nashville Teens with "Tobacco Road"; Dave Berry "The Crying Game"; The Pretty Things "Don't Bring Me Down" and Peter and Gordon "True Love Ways." Bob Kingston, Southern's active London Manager is also delighted with the emergence of Iver Recording Co., the pubbery's independent production set-up with on-the-spot studios right in the heart of Tin Pan Alley. During the year Iver has produced some resounding hits notably "Colours" by British folkster Donovan and three home grown products from contract writers John Carter, Ken Lewis and Perry Ford who, as The Ivy League, went into the charts with "Funny How Love Can Be"; "That's Why I'm Crying" and more recently with their British Song Festival entry "Tossin' and Turnin'". Many of Southern's hits have also been recreated in America and throughout to world, to whit Brenda Lee's "Is It True" a British composition recorded in this country and destined to become an international hit.

Around the corner in Charing Cross Road Francis Day & Hunter have also had an active year with the formation of two new subsidiary companies, Donna Music set up in association with hit writer and arranger Les Reed (who supplied Tom Jones with his transatlantic smash "It's Not Usual." Donna Music will handle all future compositions and they are currently lining up recordings by big name artistes. The second new company, Ventura Music, is headed by composer Ivor Slaney who last year won the Ivor Novello Award for "Carlo's Theme" and more recently penned the score for "A King's Story." Record wise F. D. & H. enjoyed their biggest hits with "Silhouettes" by Herman's Hermits high in the charts on both sides of the Atlantic which was followed by "Henry The VIII" the British oldie originally made famous at the turn of the century by comedian Harry Champion. The disk has not yet been issued here. F. D. & H. also had a couple of bullseyes with "Tokyo Melody" by Helmut Zacharias and "Marie" by The Bachelors. Bert Corri, a Director of the company is at present pre-occupied with the production of the debut disk by Roger (The Saint) Moore. Over to Robbins Music where Alan Holmes has enjoyed success with some major film score by British composer Ron Goodwin including "Operation Crossbow"; "Of Human Bondage" and the highly successful MGM movie "Those Magnificent Men In Their Flying Machines." Another screen score handled by Robbins was the box office hit "Zorba The Greek." Pop wise they took second place at the Eurovision Song Contest in Naples with Kathy Kirby's "I Belong" and have recently clicked in America via Jay and the American's revival of the oldie "Cara Mia." At Feldman Ben Nisbet ecstatic with the success in America of Freddie and the Dreamers who topped the Cash Box Top 100 with "I'm Telling You Now" an original Feldman copyright penned by Freddie in collaboration with Mitch Murray. Freddie also climbed high in America with "You Were Made For Me." Georgie Fame topped the British charts for the company with "Yeh Yeh" and made the American Top 100 with the same number. More recently

(Continued on page 14)

Philips Records Limited
Stanhope Place
London W2 England



PHILIPS



fontana

**THE BEST NEW BRITISH TALENT IS ON
PHILIPS, MERCURY AND FONTANA!!!**



England - The Past Twelve Months

(Continued from page 12)

the pubbery has had another transatlantic smash via The Yardbirds "For Your Love."

The Chappells publishing group of companies has had another highly successful year particularly with their extensive film and show music catalogue. Screen wise their hits have been "Mary Poppins"; "My Fair Lady" and "The Sound of Music." Theatrical scores have included "Little Me"; "Camelot" and "Robert and Elizabeth"—which collected an Ivor Novello Award for "The Year's Outstanding Score of Stage Musical." Chappells and its subsidiaries have also been continuously represented in the pop charts with titles such as "I'll Never Find Another You" and "A World Of Our Own" both by The Seekers; "Crying In The Chapel" by Elvis Presley; and "You're Breaking My Heart" by Keeley Smith. Via the Acuff Rose catalogue Chappells had a further run of luck with numbers like "You've Lost That Lovin' Feelin'"; "The Price Of Love"; "This Little Bird" and Roy Orbison titles "It's Over" "Pretty Woman" and "Pretty Paper." During the year Jimmy Henney, Professional Manager of Chappells for 20 years left the firm to join the Public Relations company of John Heyman. Louis Dreyfus paid his usual annual visit to London.

Dick James has added another chapter to one of the most fantastic publishing success stories of all time. The year has seen consolidation at home and expansion overseas with the establishment of his own companies in the United States of America, Australia and France and the conclusion of short term exclusive catalogue deals throughout the world. It was the year that Northern Songs went public causing as much controversy as speculation but subsequently bringing credit to the Dick James Board of Directors. Northern also concluded through its American subsidiary Maclen Music Inc. an agreement with King Features TV Cartoon

Co. for the use of a minimum of 60 songs from the series of 26 programmes being produced. Metric Music had two outstanding hits "When You Walk In The Room" by The Searchers and "Come And Stay With Me" by Marianne Faithfull; both Jackie de Shannon compositions. The outstanding Lennon-McCartney compositions of the year were "A Hard Day's Night"; "I Feel Fine" and "A Ticket To Ride." As we go to press their latest film "Help" is about to open accompanied by single and L.P. releases. Pacer Music had a major hit with the score of "Ferry Cross The Mersey" the title song by Gerry and the Pacemakers hitting charts all over the world. "It's Gonna Be All Right" also gave Pacer a transatlantic smash. Jaep had a powerful year with many numbers waxed by Billy J. Kramer. The Fourmost, Cilla Black and Cliff Bennett. During the year Dick James set up a joint company with Vic Lewis and Don Black, Lords Music, with Vic and Don writing exclusively for the company. The first number "My Child" was recorded by Connie Francis. Another new company, Gralto was also formed in association with Graham, Alan and Tony of The Hollies.

Cyril Simons of Leeds Music reports a triumphant year and a renewal of his contract with Welbeck Music for a further four years. Both companies have enjoyed consistent chart ratings over the past twelve months. Universal Pictures took over Leeds giving the pubbery all use of U.P.s catalogue of film and TV copyrights. Leeds number amongst their hits all the Bob Dylan numbers including "The Times They Are A-changing" and "Subterranean Home-sick Blues" as well as Cliff Richard's "I'm The Lonely One"; Tom Jones' "It's Not Unusual" (Leeds have also taken over Tom Jones' Valley Music Co.) Kags Music, a subsidiary of Leeds struck hard with The Rolling Stones "It's All Over Now." The biggest hit of the year for Welbeck Mu-

sic was certainly "Downtown" which took Petula Clark to the top of the world charts with total record sales around the three million mark. Welbeck had the follow-ups "I Know A Place" and "You'd Better Come Home." They also had the No. 1 smash by Jackie Trent "Where Are You Now." Elstree Music published the score of the new Frank Ifield film "Once A Jolly Swagman."

For Ardmore & Beechwood, EMI's publishing house, the sudden death in April of their General Manager and European Supervisor, Sid Coleman, was a tragic loss to the company and overshadowed their year's activities. The veteran music man's death was deeply felt throughout the industry. He has been exceeded by Harry Lewis who, until recently, presided over his own Marlyn Music Co. At home Ardmore & Beechwood have enjoyed moderate success with number such as "Rag Doll" by The Four Seasons and "Walk Away" by Matt Monro. Their latest hit has been with the Marianne Faithfull single "Summer Nights." During the year they opened a new company in Greece, Arion.

Roy Berry of Campbell Connelly Group reports a tremendous year all round. Major chart entries have been by The Honeycombs with "Have I The Right"; The Bachelors "I Believe"; The Animals "I'm Crying" and all the Dave Clark numbers including his latest single, the title number from his film "Catch Us If You Can." More recently they handled "Moonglow" film from the film "Picnic" by The Sounds Orchestral. The firm's independent production set up CeeCee have achieved remarkable success with The Downliners Sect whose single "Little Egypt" took them high in the Scandinavian charts. The group also cut an E.P. "The Sect Sings Sick Songs" and two L.P.s "The Sect" and "The Country Sect." Campbell Connelly also acquired the Pictoretone catalogue of America with all the Wes Farrell compositions.

For Shapiro Bernstein the year has

brought the company its first No. 1 hit since opening up in London. The number "I'm Alive" by The Hollies follows a string of chart entries during the past twelve months including a No. 2 with Wayne Fontana's "The Game of Love" (which made No. 1 in America); "Walk Tall" and "The Special Years" by Val Doonican and "Like A Child" by Julie Rogers. To cap their success "Leave a Little Love" waxed by Lulu which came second in the British Song Festival has now taken the artiste and the publisher high in the charts.

Bron Associated also report their most successful year so far with numbers such as Gene Pitney's "I Must Be Seeing Things" and Cliff Richard's "On My Word" as well as numbers by The Ian Campbell Folk Group and Cilla Black. Bron recently signed an agreement with Musicor of America to represent their interests in this country. They have expanded their interest into artistes management and have Marianne Faithfull under exclusive contract as well as American artiste Gene Pitney. They have also signed a new group The Quiet Five.

Sparta Music, under the energetic direction of Hal Shaper, has swung ahead. Highlights of the year have been three successive hits by The Moody Blues including "From The Bottom of My Heart" which also clicked on the continent where Sparta have stepped up their activities during the past twelve months. They recently enjoyed success with Sheila's "Il Fait Chou" and "No Tears for Johnny" by Marie Lafouret. The crowning achievement of Sparta's first year was winning the British Song Festival with "I'll Stay By You" by Kenny Lynch and Hal Shaper with covers set in France and Italy. Shaper also expanded into management with names including Cash McColl and Ray Singer and founded a new indie recording company with disks by The Brothers Grimm, Dick Haynes and The Pussycats.

(Continued on page 15)

THE INTERNATIONAL PUBLISHER OF WORLD HITS

LONDON

138-140, Charing Cross Road, London, W.C.2.

PARIS

Publications Francis-Day Societe Anonyme, 5, Avenue de l'Opera 1^{er}

AMSTERDAM

Francis-Day Muziekuitgevers N.V. Amstel 52

FRANKFURT/MAIN

Francis Day & Hunter G.M.B.H. Oederweg 26

ZURICH

Francis-Day Produktion Brunnwiesenstrasse 26

MADRID

Canciones Francis-Day Carmen 20

NEW YORK

Francis Day & Hunter Inc. 745 Fifth Avenue

BRUSSELS

Editions Francis-Day S.A. 25, Place Saint-Gery

MILAN

Edizioni Musicali Francis-Day S.R.L. Piazza Del Liberty 2

AGENTS

AUSTRALIA

J. Albert & Son Pty Ltd. 137-9, King Street, Sydney.

JAPAN

Eastern Music Publishing Company, Kyowa Building, 34, Kotochira-cho, Shiba, Minato-ku, Tokyo, Japan.



England — The Past Twelve Months

(Continued from page 14)

Noel Rogers of United Artists was the fortunate publisher of John Barry's "Goldfinger" score which topped the American L.P. charts for weeks on end and took Shirley Bassey high in the Top 100 singles stakes. United Artists also had another John Barry score "The Knack" the award winning film at Cannes Film Festival. Other film scores of the year came from "Mister Moses"; "I'll Take Sweden" and "The Greatest Story Ever Told."

For Lawrence Wright the year's highlight came with the Ivor Novello Award for "The Kipling Theme" from the BBC's TV series. Voted "The Most Outstanding Orchestral Composition of the Year" certificates of honour were presented to the composer Max Harris and to Lawrence Wright Music.

For Freddie Poser of Poser Music it has been the year of Sandie Shaw and contract writer Chris Andrews whose compositions "Girl Don't Come"; "I'll Stop At Nothing" and the chart topper "Long Live Love" has kept the songstress in the charts for months on end.

Bourne Music has just competed their first year of independent publishing in the U.K. under the management of Len Taylor. One of the highlights was the inclusion of a Bourne copyright "All The Angels Sang" by Maureen Evans in Britain's first Song Festival. As we go to press the company is riding high with "To Know You Is To Love You" by Peter and Gordon. They also had a big year with Jim Reeves "I Love You Because."

Eddie Rogers of Mediant Music had his biggest success with the British musical "Instant Marriage" which enjoyed a nine-month run in London and is now playing in Australia where the score is handled by Gil Music.

For Mills Music a year which came in like a lamb is going out like a lion. At presstime besides a couple of versions of "Shakin' All Over" and the French hit "Donna Donna" by Dana Gillespie and Chad and Jeremy, the pubbery has a formidable line up of hit potentials.

For Lionel Bart's Apollo Music an important copyright was "As Tears Go By" immortalised by Marianne Faithfull. But even more important was the success of Unit Four Plus Two with "Concrete and Clay" by top contract writers Brian Parker and Tommy Moeller. The number became an enormous success on both sides of the Atlantic as did the follow up "You've Never Been In Love Like This Before." Plans are afoot for Unit Four Plus Two to visit America in September for p.a.'s and TV.

Meantime the group's manager John L. Barker (of John L. Barker Associates) has signed a new group The Pentad whose first recording for Parlophone "Silver Dagger" is also published by Apollo. These pop successes mark a new phase in the pubbery's success story and indicate a breakaway from the exclusivity of musicals. In this direction "Maggie May" continues its long run and is scheduled for Broadway presentation in 1966 after which it will be filmed. "Oliver" is still playing to capacity both in London and New York and Bart's latest stage epic "Twang" based on the Robin Hood story with book by Harvey Orkin is due for its London premiere in October.

Essex Music expanded their staff, installed a mechanised accounting system and are currently planning to move into larger premises. They acquired the Lakeview catalogue which includes the score of Lionel Bart's "Oliver." They also took over Matt Monroe's publishing company, Contango.

The Burlington-Palace group of companies have had a long list of hits by many top artistes from both sides of the Atlantic. From America the late Jim Reeves provided them with "I Won't Forget You" (with sheet music sales nearing 30,000) "There's A Heartache Following Me"; "Not Until The Next Time" and the latest Reeves single "This World Is Not My Home." The pubbery also chalked up some healthy sheet music sales with Roger Miller's "King of the Road" which also achieved very high record sales reaching the No. 2 position and they also have the follow up "Engine Engine No. 9." Also from America came two Beachboys hits "I Get Around" and "Dance Dance Dance." British hits included "Someone Someone" by Brian Poole and the Tremeloes and "No Arms Can Ever Hold You" by The Bachelors. During the year Burlington acquired several new catalogues including Sagatarium Acclaim and Tuchae.

The Belinda (London) Aberbach group of companies has been well represented in chartsville. Belinda with "What Do You Want With Me" by Chad and Jeremy; "Sha La La" by Manfred Mann; "Sweet William" Millie and The Searchers smash "Love Potion No. 9." Aberbach had The Beatles "Matchbox" and 17 Savile Row cashed in "Trains and Boats and Planes."

Philip Solomon who has recently taken over complete control of the Philip Solomon group of companies has had a bumper year both in the recording and publishing fields. His indie record company has notched up hits with three successive disks by Twinkle "Terry"; "Golden Lights" and "Tommy" and Belfast group Them established themselves with "Baby Please Don't Go"; "Here Comes The Night" and "One More Time," all issued here on Decca and in America

on London. A succession of hits for The Bachelors included "I Wouldn't Change You For The World"; "No Arms Can Ever Hold You"; "True Love For Evermore" and their latest transatlantic smash "Marie." As record producers the company also had a good year in the Irish Hit Parade via Showbands such as The Capitol Showband, The Cadets and The Pacific. However, the biggest hit in Ireland was with the Emerald Isle's first entry in the TV song contest "Walking The Streets in the Rain" (now waxed in the United States by Jane Morgan) which Solomon also publishes. Other publishing hits for the 142 group of companies included "Terry"; "I Wouldn't Change You For The World" and the Jim Reeves charter "It Hurts So Much."

Harold Geller of Lynn Music reports that the company's second year has been most rewarding. Highlights being half a million records sold of Richard Anthony's "Come To Me" and the Gold Disk in Japan for The Honeycombs "That's The Way." Lucky on the home front Geller is equally pleased with his American tie up with Andy Badelle and Frank Stanton.

K.P.M. had a boomerang success with "The Wedding" by Julie Rogers. The original melody "La Novia" published by Fermato Music in Buenos Aires was acquired by KPM from the Bendig Music Corp of America in 1961—stayed at the top of the Best Selling Sheet Music Lists for several weeks. They also handled "She Loves To Be Loved" by The Falling Leaves and had the first big hit for Shirley Ellis in Britain "The Clapping Song"—a just reward after failing to make it here with her American successes.

Mellin Music had the first Top 20 hit by Cliff Bennett "One Way Love." They also had Del Shannon's "Do You Want To Dance" and "It's All Over" (Continued on page 18)

Congratulations from
Lionel Bart

APOLLO

MUSIC LIMITED

Subsidiary Companies:

TRELION MUSIC CO., LTD.

FORWARD MUSIC LTD.

SOLIHULL MUSIC LTD.

Telephone:—TEMPLEBAR.—0022

Telegrams:—APOLLOMUSE LONDON.

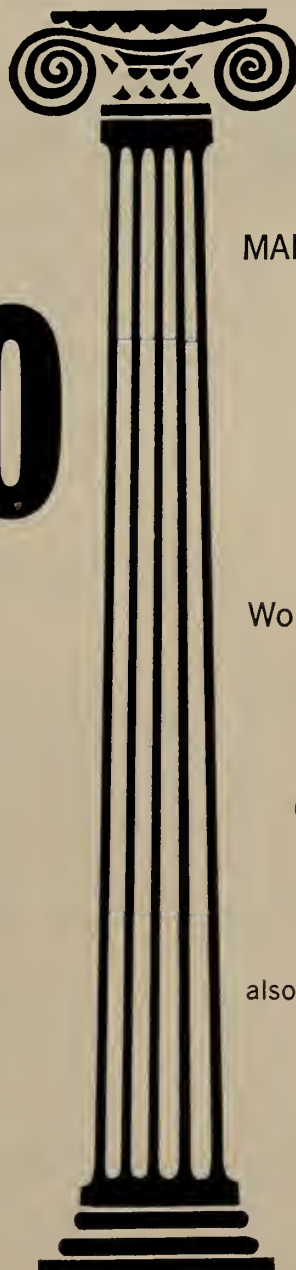

JOHN BARKER

ASSOCIATES LTD.

MANAGEMENT • AGENCY • RECORD PRODUCTION

SOLELY REPRESENTING: —

UNIT FOUR PLUS TWO

World hits:

"CONCRETE AND CLAY"

and their current release:

"YOU'VE NEVER BEEN IN LOVE LIKE THIS BEFORE"

also representing:— THE PENTAD
THE POOR SOLES
BOZ

164 SHAFTESBURY AVE.
LONDON W.C.2.

Telephone:—COVENT GARDENS:—0572

**WE
SELL
THEM
HERE!**

DISC WEEKLY, June 5, 1965

**DISC
weekly**

- 1 LONG LIVE LOVE..... Sandie Shaw(Pye)
- 2 POOR MAN'S SON....Rockin' Berries(Piccadilly)
- 3 WHERE ARE YOU NOW?..... Jackie Trent(Pye)

Cash Box TOP 100

**WE SELL
THEM
THERE!**

1	DOWNTOWN	1/16	1/9
	☆PETULA CLARK-Warner Bros.-7194	4	12
2	LOVE POTION NO. 9		
	☆SEARCHERS-Kapp-KJB-27	3	4
3	YOU'VE LOST THAT LOVIN' FEELING		
	☆RIGHTEOUS BROS.-Philles-124	5	7
4	I FEEL FINE		
	Capitol-5327	1	
5	TIRED OF WAITING FOR YOU		
	☆FREDDIE & DREAMERS-Tower-125	1	1
	☆KINKS-Kapp-0347	7	12
17	CAST YOUR FATE TO THE WIND		
	☆SOUNDS ORCHESTRAL-Parkway-942	23	30
18	BUMBLE BEE		
	☆SEARCHERS-Kapp-49	21	26

WE SELL RECORDS EVERYWHERE!

We also make quite good stuff too - the following are a few of the recordings made in the Pye Studio's - we hope you have heard of one or two of them.

**DOWNTOWN, PETULA CLARK - BUMBLE BEE,
THE SEARCHERS - TIRED OF WAITING, THE KINKS
YEAH YEAH, GEORGIE FAME - TOBACCO ROAD,
THE NASHVILLE TEENS - LOVE POTION NO. 9,
THE SEARCHERS - I KNOW A PLACE, PETULA
CLARK - CAST YOUR FATE TO THE WIND,
SOUNDS ORCHESTRAL**

ALL ENQUIRIES: THE STUDIO MANAGER, PYE RECORDS STUDIOS, A.T.V. HOUSE, GREAT CUMBERLAND PLACE, LONDON, W.1. TELEPHONE: AMBASSADOR 5502

AMERICAN REPRESENTATIVE: IRVING CHEZEAR, 555 MADISON AVENUE, NEW YORK CITY 22
TELEPHONE: PLAZA 52100

DELYSÉ

for
fine
RECORDS

DELYSÉ

for
good
SERVICE

DELYSÉ

for
superb
sound

DELYSÉ

for
dynamic
distribution

DELYSÉ

for
International
Repertoire

DELYSÉ

for
Every Taste

DELYSÉ

the Independent
Recording
Company
of
25 Marylebone
Road, N.W.1.
London,
England.

England—

The Past 12 Months

(Continued from page 15)

Now" by Ben E. King. Mellin also acquired the Tender Tunes catalogue for all territories outside the USA and Canada which soon brought them a sustained hit with "Remember (Walking In The Sand)" by The Shangri Las and their follow up "Leader of the Pack."

Another pubbery with recording interests for whom 1964/65 has been a notable year of progression is marquis Enterprises under the direction of Joe Roncoroni and Ken Jones. The Zombies have triumphed on both sides of the Atlantic with numbers such as "She's Not There" which after six weeks in the British Top 20 shot to No. 1 in America and won the group a Cash Box International Gold Award. "Tell Her No" and "She's Not There" were both penned by group member Rod Argent. The latest artiste and copyright to be handled by Marquis is Jonathan King's own composition "Everyone's Gone to the Moon."

Lee Pincus of Ambassador Music has made several tours of the continent during the year acquiring such copyrights as the Italian hits as "Amore Scusami"—a John Foster composition retitled in English "My Love Forgive Me." Another John Foster composition "Cominciamo Ad Amarci" retitled "Begin to Love" was also handled by Ambassador with recordings by Robert Goulet, The Bachelors and John Foster. One of the pubbery's biggest hits came this year with The Shadows "Stingray." Pincus signed a new group The Shades of Blue to a management deal with a debut disk "Voodoo Blues."

The Rank Organisation relinquished their interest in their publishing subsidiary Filmusic but the company has remained fully operative under the guidance of Harold Shampan who has been General Manager since the formation of Filmusic six years ago. Shampan is continuing to build the pubbery's strong catalogue of film music and is also active on the agency/recording side. His artistes include The Zephyrs. He also formed Pall Mall Music for the exploitation of pop music.

Active in all branches of the business Tito Burns has had a successful year in publishing (Toby Music), Lindon Records (Indie Production) and in artistes management and promotion. On the publishing side Toby Music has had its biggest seller with The Searchers latest single "He's Got No Love." Lindon Records latest production was Alma Cogan's "Snakes & Snails." On the Agent/Management side Tito Burns Productions has taken a creative stand rewarded by successful T.V. Specials by top world artistes

such as Burt Bacharach, Dusty Springfield, Dione Warwick, Bob Dylan etc. Burns also introduced new names into Britain including Woody Allen, Roger Miller, Peter Nero and Vikki Carr.

For John Fields Music the year has seen a move into new offices and the company is now in the heart of Soho. Early this year Harold Fields made one of his periodical visits to America which combined discussions with publishers and a quest for new composer/arranger talent and exchange deals. One of the pubberies numbers of the year was "I Will Never Let You Go" by the U.K.s.

Since the demise of Baton Music here Roy Pitt has been appointed General Manager of Good Music which is now operated within the aegis of the Essex Music publishing house.

As always the year has seen the formation of several new companies amongst them Millwick Ltd. managed by Jack Heath who is delighted with the first year's operation. The firm's owner/director Lionel Segal, writer, composer and record producer has been responsible for Millwick copyrights "As I Watch You Walk Away" by Martha Smith; "I've Often Wondered" by Maureen Evans and Monty Babson; "A Woman Needs" by Peter Elliott and waxed for America by Keeley Smith. Segal has just completed a new British musical "My Girl" based on the book "Little Women" and is scheduled for production this coming season. Millwick has signed five young writers including Miki Dallon, and one of his songs "Take A Heart" has already been released.

Another important new company Shadam was set up by The Shadows and three new British writers Chris Arnold, David Martin and Geoff Morrow in association with Aberbach Music. The firm which operates from 17 Savile Row already has recordings lined up by Cliff Richard and Frank Ifield.

The year has seen the formation in Britain of a new Screen Gems set-up previously handled here by Dominion Music. The newly formed company is under the direction of Jack Magraw and will handle all Screen Gems—Columbia Music copyrights in the U.K. The company is already negotiating for a number of European catalogues. They also aim to establish a team of British writers. The firm kicked off 1965 with "You've Lost That Lovin' Feelin'" and the new set-up which took effect from July 1st immediately went into the charts with The Animals "We've Gotta Get Out Of This Place."

EMERALD RECORDS LTD.

are pleased to announce that we provide masters for some of the world's largest recording organisations. Masters now available on LPs both stereo and mono for territories all over the world. The Irish invasion is already high on the world charts today. For further information contact:

MERVYN A. SOLOMON, 67-69 ANN ST., BELFAST 1, NORTHERN IRELAND
Members of the International Federation of the Phonographic Industry

SERVING THE INTERNATIONAL MUSIC BUSINESS

FASTEST RECORD DELIVERY THROUGHOUT THE WORLD BY AIR MAIL
COMPLETE LINE OF ALL AMERICAN LABELS

ALL NEW RELEASES

Every quantity shipped. Prices on request.

AIRDISC U.S.A.

Box 545, Radio City Station
New York, N. Y. 10019

SINGLES • ALBUMS

Payments by bank draft or International Money Order or on account.

DELYSÉ

for
fine
RECORDS

DELYSÉ

for
good
SERVICE

DELYSÉ

for
superb
sound

DELYSÉ

for
dynamic
distribution

DELYSÉ

for
International
Repertoire

DELYSÉ

for
Every Taste

DELYSÉ

the Independent
Recording
Company
of
25 Marylebone
Road, N.W.1.
London,
England.

BRITISH RECORD MANUFACTURERS

ARGO RECORD COMPANY
113, Fulham Road,
London, S.W.3.
Tel: Knightsbridge 4256
Managing Director: H. J. Usill
Label: Argo

ASSOCIATED RECORDINGS COMPANY
326, Kensal Road,
London, W. 10.
Tel: Ladbroke 6651
Managing Director: Marcel Rodd
Labels: Saga, Dandy, Language Records,
Heritage, Fidelity, Eros, Opus, Society
Lyrique, Presto, Silver Dollar

COLLECTOR RECORDS
39, Greenford Gardens,
Greenford, M'sex.
Tel: Waxlow 1545
Managing Director: Colin Pomeroy
Labels: Collector, Jazz Collector, Range

CBS RECORDS LTD.
104, New Bond Street,
London, W.1.
Tel: Grosvenor 5301
Managing Director: Morris Levy
Labels: CBS, Oriole, Realm, Embassy, Senator,
Oriole-Eurodisc, Time-Oriole.
Distributors of: CBS, Time, Savoy, Ariola

CROSSBOW RECORDS
47, Dean Street,
London, W. 1.
Tel: Regent 7451
Managing Director: Allan Crawford
Labels: Crossbow, Sabre, Carnival

THE DECCA RECORD COMPANY LTD.
Decca House,
9, Albert Embankment,
London, S.E.1.
Tel: Reliance 8111
Chairman: Sir Edward Lewis
Director & Commercial Manager: W. W.
Townsend
Labels: Decca, Ace of Clubs, Ace of Diamonds,
London, Atlantic, London Globe, RCA
Victor, RCA Victrola, RCA Camden, Brunsw-
wick, Ace of Hearts, London Editions de
L'Oiseau Lyre, Argo, Telefunken, Coral,
Vocalion, Contemporary, Good Time Jazz,
Beltona
Distributors of: Atlantic, Bigtop, Carlton,
Challenge, Del-Fi, Era, Kapp, King Group,
Monument, Sun, Starday, American Decca
Group, American London Group, Ava, Con-
gress, Philips and others.

DELYSE-ENVOY RECORDS LTD.
27, Marylebone Road,
London, W. 1.
Tel: Hunter 4266
Managing Director: Isabella Wallich
Labels: Delyse, Envoy.

**DEUTSCHE GRAMMOPHON (GREAT BRI-
TAIN) LTD.**
12/12, Rathbone Place,
Oxford Street, London, W.1.
Tel: Langham 8156/7/8/9
Labels: Deutsche Grammophon, Archive Pro-
duction, Heliodor, Polydor
Managing Director: W. Reimer

EMBER RECORDS
York House,
Empire Way,
Wembley, M'sex.
Tel: Diligence 1077
Managing Director: Jeffrey Kruger
Label: Ember
Distributors of: Circa, Ambassador, Sun,
Aravel, LMI, Barclay, Kapp, Pallette,
Davon, Bethlehem, Request, King, Starday,
Rondo, Transglobal, Flip, Everest, Kent.

EMERALD RECORDS LTD.
67/69, Ann Street,
Belfast 1,
Northern Ireland
Tel: 31616
President: Mervyn A. Solomon
Label: Emerald

EMI RECORDS
EMI House,
20, Manchester Square,
London, W. 1.
Tel: Hunter 4488
Managing Director: L. G. Wood
Labels: HMV, Capitol, Columbia, Parlophone,
Regal-Zonophone, Encore, Stateside, M.G.M.,
Liberty, United Artists, Verve, Tamla Mo-
town
Distributors of: ABC Paramount Inc (USA),
Amy-Mala (USA), Ascot (USA), Apollo
(USA), Buenavista (USA), DCP (USA),
Disneyland (USA), Diamond (USA), Dol-
ton (USA), Epic (USA), Festival (Austra-
lia), Global (USA), Imperial (USA), Im-
pulse (USA), Institute for Language Study
(USA), La Forge Regina (USA), Laurie
(USA), Metronome (Denmark), Musicor
(USA), Okeh (USA), Prestige (USA),
Rendezvous (USA), Rooset (USA), Roulette
(USA), Sonet (Sweden), Swan (USA), Tico
(USA), Tower (USA), Twentieth Century
Fox (USA), Westminster (USA), World
Artists (USA).

EVEREST PLASTICS LTD.
Victoria Works,
Edgware Road,
London, N.W.2.
Tel: Dollis Hill 7746/50
Managing Director: Monty Lewis
Labels: Rainbow, Instant Learning

ISLAND RECORDS
108, Cambridge Road,
London, N.W.6.
Tel: Kilburn 1922
Managing Director: Christopher Blackwell
Labels: Island, Surprise, Jump-Up, Black
Swan, Sue.

JUPITER RECORDINGS LTD.
140, Kensington Church Street,
London, W. 8.
Tel: Bayswater 9531
Artistic Director: V. Clinton-Baddeley
Label: Jupiter

LEOMARK LTD.
Winchester House,
77, London Wall,
London, E.C.2.
Tel: London Wall 1815
Secretary: S. Thackray
Label: Leomark

MELODISC RECORDS LTD.
12, Earham Street,
London, W.C.2.
Tel: Covent Garden 2848
Managing Director: Emil Shalit
Labels: Melodisc, Bluebeat, Dice, Kalypso

PHILIPS RECORDS LTD.
Stanhope House,
Stanhope Place,
London, W. 1.
Tel: Ambassador 7788
General Manager: Leslie Gould
Labels: Philips, Fontana, Riverside, Caedmon,
Mercury
Distributors of: Vanguard, VeeJay, Jay Gee,
Mercury, Smash

**PICKWICK (INTERNATIONAL) GREAT
BRITAIN LTD.**
Victoria Works,
Edgware Road,
London, N.W.2.
Tel: Dollis Hill 7746/50
Managing Director: Monty Lewis
Labels: Pickwick, Happy Time, Allegro,
Bravo

PYE RECORDS LTD.
A.T.V. House,
Great Cumberland Place,
London, W. 1.
Tel: Ambassador 5502
Managing Director: Louis Benjamin
Labels: Cameo-Parkway, Colpix, Golden
Guinea, Hickory, Red Bird, Piccadilly, Pye,
Pye International, Pye Jazz, Reprise, War-
ner Bros., Dot, Vogue, Durium, Pye Com-
mand, Marble Arch, Face to Face
Distributors of: Miller International (USA),
Scepter (USA), Wand, Mace, A & M, Almo,
Autumn, Jerden, Crusader, Charger, Try,
Palette, Deutsche Vogue, Blue Cat, Daisy,
Tiger, Dimension, Paula, Wyncote.

R & B DISCS LTD.
282, Stamford Hill,
London, N. 16.
Tel: Stamford Hill 4127
Managing Directors: Mr. & Mrs. Isen &
M. Hitchen
Labels: R & B, Prima, Ska-Beat.
Distributors of: Delta (Holland), Sonet
(Sweden), Tremore, Kent

77 RECORDS LTD.
77, Charing Cross Road,
London, W.C.2.
Tel: Gerard 4197
Managing Director: Doug Dobell
Labels: 77, Folklore

TALENT RECORD COMPANY
76, Bedford Court Mansions,
Bedford Avenue,
London, W.C.1.
Tel: Museum 1810
Managing Director: Carlo Kramer
Label: Talent
Distributors of: Delmark

TOPIC RECORDS LTD.
27, Nassington Road,
London, N.W.3.
Tel: Hampstead 9983
Managing Director: G. Sharp
Label: Topic

TRANSATLANTIC RECORDS LTD.
120/122, Marylebone Lane,
London, W. 1.
Tel: Hunter 4353/6
Managing Director: Nathan Joseph
Labels: Transatlantic, Xtra, Storyville
Distributors of: Folkways, Conversaphone,
M.K. (USSR)

VOGUE RECORDS LTD.
113/115, Fulham Road,
London, S.W.3.
Tel: Knightsbridge 4256
General Manager: E. Mills
Labels: Vocalion, Contemporary, Emerald,
Good Time Jazz

VOX PRODUCTIONS (G.B.) LTD.
231, Oxford Street,
London, W. 1.
Tel: Gerard 7482
Managing Director: P. Fejer
Label: Vox

WAVERLEY RECORDS
6/8 Bread Street,
Edinburgh 3,
Scotland
Tel: Fountainbridge 8389
Managing Director: T. B. Laing
Labels: Waverley, Talisman

WORLD RECORD CLUB
Parkbridge House,
Little Green,
Richmond, Surrey,
Tel: Richmond 3646
Chairman: Norman Lonsdale
Labels: World Record Club, Conquest

The Greatest **INTERNATIONAL** Publishing Business



LINKS THE WORLD

IN EUROPE

LONDON:

**SOUTHERN MUSIC PUBLISHING CO.
LTD.** and associated companies
8, Denmark Street.

PARIS:

**S.E.M.I.
LES NOUVELLES EDITIONS
MERIDIAN**
5 Rue Lincoln.

HAMBURG:

PEER MUSIKVERLAG and associated
companies
Klaerchenstrasse 11.

EDITION MARBOT
Bornstrasse 12.

MILAN:

EDIZIONI SOUTHERN MUSIC and
associated companies
Piazzetta Pattari 2.

BARCELONA:

**SOUTHERN MUSIC
ESPANOLA**
Diputacion 337.

MADRID:

MUSICA DEL SUR
Hortaleza 18.

STOCKHOLM:

SOUTHERN MUSIC A.B.
Grev Turegatan 38.

AMSTERDAM:

HOLLAND MUSIC
Singel 500.

BRUSSELS:

SOUTHERN MUSIC (BELGIUM) S.A.
13 Rue de la Madeleine.

VIENNA:

SOUTHERN MUSIC WIEN GmbH
Seilergasse 12.

SWITZERLAND:

SOUTHERN MUSIC A.G.
Hausmelodie, 8604 Volketswil.

and all over the world.

BRITISH INDEPENDENT RECORD PRODUCERS

THE HUB OF ENGLAND'S MUSIC BUSINESS

THE WORLD WIDE ORGANISATION OF DICK JAMES MUSIC LTD.

GRALTO MUSIC LTD.
JAEP MUSIC LTD.
LORDS MUSIC LTD.
NORTHERN SONGS LTD.
PAGERMUSIC LTD.

JAMES HOUSE, 71-75 NEW OXFORD ST. LONDON W.C.1.
Tel. TEMple bar 1687
Cables DEJAMUS, LONDON

ANDESOUND LTD.
138, Ivor Court, Gloucester Place,
London, N.W.1.
Tel: Ambassador 1811
Andrew Loog Oldham

J.B. INDEPENDENT PRODUCTIONS LTD.
19, Great Newport Street,
London, W.C.2.
Tel: Temple Bar 4718
John Barry

SYDNEY BRON MUSIC CO. LTD.
133a, Charing Cross Road,
London, W.C.2.
Tel: Gerrard 5063
Gerry Bron

TONY CALDER LTD.
147, Ivor Court, Gloucester Place,
London, N.W.1.
Tel: Ambassador 2701
Tony Calder

CEE CEE PRODUCTIONS LTD.
10, Denmark Street,
London, W.C.2.
Tel: Temple Bar 1653
Mike Collier

CITY MUSIC
8, Radnor House,
93/97, Regent Street,
London, W.1.
Tel: Regent 5351
B. A. Palmer

FXB PRODUCTIONS LTD.
9, Daver Court,
Chelsea Manor Street,
London, S.W.3.
Tel: Flaxman 7398
Tom Springfield

IVER RECORDING CO. LTD.
8, Denmark Street,
London, W.C.2.
Tel: Temple Bar 4524
Terry Kennedy

MARQUIS ENTERPRISES LTD.
37, Soho Square,
London, W.1.
Tel: Gerrard 9405
Joe Roncoroni & Ken Thorne

MILLWICK LTD.
Suite 15, 43, Upper Berkeley Street,
London, W.1.
Tel: Ambassador 3583
Jack Heath

LINDON RECORDS LTD.
3, Vere Street,
London, W.1.
Tel: Hyde Park 8751
Tito Burns

MANFREDISCS LTD.
35, Curzon Street,
London, W.1.
Tel: Grosvenor 7905
Manfred Mann

DEUTSCHE GRAMMOPHON (G.B.) LTD.
12, Rathbone Place,
London, W. 1.

E.M.I.
11/15, William Road,
London, N.W.1.

E.M.I.
17, Fazeley Street,
Birmingham 5.

E.M.I.
Regent House,
30, Cannon Street,
Manchester 4.

E.M.I.
131, Renfield Street,
Glasgow.

E.M.I.
26, Progress Way,
Purley Way,
Croydon, Surrey.

KEITH PROWSE & COMPANY LTD.
Wholesale Record Division,
202, Tooting High Street,
London, W. 1.

LUGTON & CO. LTD.
209/212, Tottenham Court Road,
London, W. 1.

PHILIPS RECORDS LTD.
Stanhope House,
Stanhope Place,
London, W. 1.

PHILIPS RECORDS LTD.
P.O. Box 90,
Beddington Farm Road,
Croydon, Surrey.

PHILIPS RECORDS LTD.
P.O. Box 450,
Lloyd Street,
Manchester 2.

PHILIPS RECORDS LTD.
P.O. Box 131,
Floodgate Street,
Birmingham 5.

PHILIPS RECORDS LTD.
26, Bothwell Street,
Glasgow C.2.

ORBIT UNIVERSAL MUSIC CO.
34, Greek Street,
London, W.1.
Tel: Regent 2148
Shel Talmy

RAK RECORDS LTD.
Mayfair House, 101, Dean Street,
London, W.1.
Tel: Gerrard 6671
Micky Most

RIOT PRODUCTIONS
39/41, New Bond Street,
London, W.1.
Tel: Hyde Park 1251
Roy Pitt

RECORD SUPERVISION LTD.
Lansdowne House, Lansdowne Road,
London, W.11.
Tel: Park 0041
Denis Preston

RITZ RECORDS
Flat 6, Albert Gate Court,
124, Knightsbridge,
London, S.W.1.
Tel: Knightsbridge 8801
Bunny Lewis

R.G.M. SOUND LTD.
304, Holloway Road,
London, N.7.
Tel: North 4074
Joe Meek

MEEKSVILLE SOUND
304, Holloway Road,
London, N.7.
Tel: North 4074
Joe Meek

RYEMUSE SOUND STUDIOS
64, South Molton Street,
London, W.1.
Tel: Grosvenor 7173
Johnny Gregory

SCOTT-SOLOMON PRODUCTIONS LTD.
73/75, New Oxford Street,
London, W.C.1.
Tel: Temple Bar 1801
Tommy Scott & Philip Solomon

STANLEY SCHOFIELD PRODUCTIONS LTD.
6/8, Old Bond Street,
London, W.1.
Tel: Mayfair 4642
Stanley Schofield

STRAND RECORDS LTD.
41, Kingsway,
London, W.C.2.
Tel: Temple Bar 3611
Tony Hiller

ROBERT STIGWOOD INTERNATIONAL LTD.
41, Kingsway,
London, W.C.2.
Tel: Temple Bar 3611
Robert Stigwood

BRITISH GRAMMOPHONE RECORD DISTRIBUTORS

PYE RECORDS LTD.
132, Western Road,
Mitcham, Surrey.

PYE RECORDS LTD.
Ralli Buildings,
Salford 3.

PYE RECORDS LTD.
9a, Upper Accommodation Road,
Leeds 9.

PYE RECORDS LTD.
80, York Street,
Glasgow C.2.

PYE RECORDS LTD.
1a, Dora Road,
Small Heath,
Birmingham.

PYE RECORDS LTD.
Silcocks Bros. (Bristol) Ltd.
227, Cheltenham Road,
Bristol 6.

PYE RECORDS LTD.
Symphola Ltd.
14, Adelaide Street,
Belfast 2.

PYE RECORDS LTD.
24, Mountjoy Square,
Dublin.

SELECTA GRAMMOPHONES LTD.
50, Southwark Bridge Road,
London, S.E.1.

SELECTA (MIDLANDS) LTD.
Leicester.

SELECTA (NORTHERN) LTD.
Newcastle-upon-Tyne.

SELECTA (MANCHESTER) LTD.
Failsworth,
Manchester.

SOLOMON & PERES
67/69, Ann Street,
Belfast 1,
Ireland.

SOLOMON & PERES,
2, Dame Lane,
Trinity Street,
Eire,
Dublin.

H. R. TAYLLOR (BIRMINGHAM) LTD.
34, Pershore Street,
Birmingham 5.
(Also branch at Liverpool)

VOGUE RECORDS LTD.
113/115, Fulham Road,
London, S.W.3.

E. A. WOOD LTD.
7, Freeman Street,
Birmingham 5.

PHILIP WOOLFSON & CO. LTD.
633, Cadogan Street,
Glasgow C.2.

BRITISH TAPE MANUFACTURERS

AMPEX Ltd.
72, Berkeley Avenue, Reading, Berkshire.

AGFA Ltd.
27, Regent Street, London, W.1.

AUDIOTAPE Ltd.
14, Clifton Street, London, W.C.2.

BASF Chemicals Ltd.
York House, 199, Westminster Bridge Road, London, S.E.1.

BRAND FIVE FERRODYNAMIC,
Electro Techro Dynamics, 101, Leadenhall Street, London, E.C.3.

EMITAPE E.M.I. Sales & Service Ltd.
Blyth Road, Hayes, Middlesex.

GEVASNOR Gevaert Ltd.
Great West Road, Brentford, Middlesex.

DESMOND BURGESS Ltd.
Watling House, Watling Street, London, E.C.3.

ILFORD Ltd.
Ilford, Essex.

KODAK Ltd.
Kingsway, London, W.C.2.

MASTER TAPES M.S.S. Recording Co. Ltd.
Colnbrook, Buckinghamshire.

PHILIPS Philips Electrical Ltd.
Century House, Shaftesbury Avenue, London, S.W.1.

SCOTCH Minnesota & Mining Manufacturing Co.
3M House, Wigmore Street, London, W.1.

SONOCOLOUR, Tape Recorders (Electronics)
784, High Road, Tottenham, N.11.

TELEFUNKEN Ltd.
27, Chancery Lane, London, W.C.2.

MANUFACTURERS BRITISH LABEL & SLEEVE

COCKAYNE & COMPANY LTD.
268/282, Waterloo Road, London, S.E. 1

GARROD & LOFTHOUSE LTD.
6, Langley Street, London, W. C. 2.

GRAPHIS PRESS LTD.
1/3, Highbury Station Road, London, N. 1.

HAYCOCK PRESS LTD.
2, Exmoor Street, London, W. 10.

E. HANNIBAL & CO. LTD.
Pinfold Road, Thurmaston, Leicester.

HARRISON & SONS LTD.
Printing House Lane, Hayes, Middlesex.

HOWARD PRINTERS (SLOUGH) LTD.
51, Chandos Street, Slough, Buckinghamshire.

ST. JAMES PRESS
Fircroft Way, Edenbridge, Kent.

CHARLES H. STARLIGH & CO. LTD.
St. Brelades Works, Printing House Lane, Hayes, Middlesex.

ROBERT STACE & CO. LTD.
Industrial Estate, Tunbridge Wells, Kent.

WEST BROTHERS PRINTERS LTD.
186/190, Streatham Road, Mitcham, Surrey.

BEST SELLING SHEET MUSIC IN BRITAIN JUNE 1964 to JUNE 1965

TITLE	PUBLISHER
B A Hard Day's Night	Northern Songs
B All Day And All Of The Night	Kassner
B A World Of Our Own	Springfield
A Cast Your Fate To The Wind	Robert Mellin
B Catch The Wind	Southern
A Crying In The Chapel	Edwin Morris
A Do Wha Diddy Diddy	West One
B Downtown	Welbeck
A Go Now	Sparta
A Hello Dolly	Edwin Morris
B Have I The Right	Ivy
B It's Not Unusual	Leeds
B I'll Never Find Another You	Springfield
A It's Over	Acuff Rose
A It's All Over Now	Kags
A I'm Into Something Good	Rogers
A I Wouldn't Trade You For The World	142 Music
A I Won't Forget You	Palace
B I Feel Fine	Northern Songs
B Juliet	Flamingo
A King Of The Road	Burlington
B Long Live Love	Glissando
A Little Red Rooster	Jewel
A Oh Pretty Woman	Acuff Rose
A Someone Someone	Burlington
A Sha La La	Belinda
A Silhouettes	Francis Day & Hunter
B Tired Of Waiting For You	Kassner
A The Special Years	Shapiro Bernstein
A Trains & Boats & Planes	17 Savile Row
B The Last Time	Mirage
A The Minute You're Gone	Jewel
B Ticket To Ride	Northern Songs
F/B This Is My Prayer	Chappell
B The House Of The Rising Sun	Keith Prowse
F/B The Wedding	Peter Maurice
B Where Are You Now	Welbeck
F/B Walk Away	Ardmore & Beechwood
A Walk Tall	Shapiro Bernstein
F/B You're My World	Aberbach
B You Really Got Me	Kassner
A Yeh Yeh	Feldman
A You've Lost That Lovin' Feelin'	Screen Gems

B British copyrights

A American copyrights

F/B Foreign/British



Following on Argo's triumphant recording of the complete works of William Shakespeare on 137 LPs we have now started on

THE ENGLISH POETS from Chaucer to Yeats

recorded in association with The British Council
and Oxford University Press

Directed by George Rylands and read by some of the
most illustrious actors and actresses in the
English-speaking theatre including

Peggy Ashcroft
Alan Bates
Richard Burton
Richard Johnson
Michael Redgrave
Patrick Wymark

The first 20 records are now available

'A SPLENDOR OF ENGLISH SPEECH'

J. C. Trewin, Birmingham Post

Please write for details to

ARGO RECORD COMPANY LTD.

113 Fulham Road London SW 3
A DIVISION OF THE DECCA GROUP

IN ONLY 5 Years
We are handling
MORE Labels, MORE
Records, MORE
Artists than
any other
British independent
transatlantic records Ltd
folkways • storyville • xtra • mk •
transatlantic • conversaphone
PRODUCTION • PROMOTION • DISTRIBUTION
120 MARYLEBONE LANE W.1

TOBY MUSIC

(A Division of Tito Burns Prods. Ltd.)

LINDON RECORDS

(A Division of Tito Burns Prods. Ltd.)

3, VERE STREET
LONDON, W.1.

Tel. Hyde Park: 8751

Cables: TITOBURNS London



ember records
YORK HOUSE - EMPIRE WAY
WEMBLEY - MIDDLESEX

ENGLAND
Cable: KRUGENT WEMBLEY
Phone Diligence 1077

the company that gave
the record world ...

***Chad and
Jeremy**

5 consecutive single hits
2 LP chart successes USA

***John Barry**

the composer of all the
James Bond film music

hit ember single
"From Russia With Love"
c/w "007"

hit album—original
soundtrack motion picture
"ZULU"

and soon
2 great new LPs
"John Barry plays 007"
"John Barry meets
Chad & Jeremy"

*the company that launched
the Award Winning LP
"Fool Britannia"

**Peter & Anthony
Sellers & Newley**

*A top ten album
in England in 1964

"the exciting sounds of
Roy Orbison"

*Coming soon in the
United States on
Columbia Records
a great new British talent

Ray Singer

*a star-studded new
comedy album

starring
**Noel & Mel
Coward & Ferrer**

ember records
York House — Empire Way
Wembley — Middlesex — England
phone: Diligence 1077

**BEST SELLING SINGLES FROM E.M.I.
JUNE 1964 to JUNE 1965**

A Hard Day's Night	The Beatles	Parlophone
Baby Love	The Supremes	Tamla Motown
Call Up The Groups	The Barron Knights	Columbia
Come Tomorrow	Manfred Mann	H.M.V.
Do Wah Diddy Diddy	Manfred Mann	H.M.V.
Don't Let Me Be Misunderstood	The Animals	Columbia
From a Window	Billy J. Kramer	Parlophone
Ferry Cross The Mersey	Gerry and the Pacemakers	Columbia
For Your Love	The Yardbirds	Columbia
House Of The Rising Sun	The Animals	Columbia
It's For You	Cilla Black	Parlophone
I Get Around	The Beach Boys	Capitol
I'm Into Something Good	Herman's Hermits	Columbia
I'm Crying	The Animals	Columbia
I'm Gonna Be Strong	Gene Pitney	Stateside
I Understand	Freddie and the Dreamers	Columbia
I Feel Fine	The Beatles	Parlophone
I Could Easily Fall	Cliff Richard	Columbia
I'll Never Find Another You	The Seekers	Columbia
I Must Be Seeing Things	Gene Pitney	Stateside
Keep Searchin'	Del Shannon	Stateside
Looking Thru The Eyes Of Love	Gene Pitney	Stateside
Message To Martha	Adam Faith	Parlophone
On My Word	Cliff Richard	Columbia
Pop Go The Workers	The Barron Knights	Columbia
Sha La La	Manfred Mann	H.M.V.
Somewhere	P. J. Proby	Liberty
Silhouettes	Herman's Hermits	Columbia
Thinking Of You Baby	Dave Clark Five	Columbia
Twelfth Of Never	Cliff Richard	Columbia
The Minute You're Gone	Cliff Richard	Columbia
Ticket To Ride	The Beatles	Parlophone
True Love Ways	Peter and Gordon	Columbia
Where Did Our Love Go	The Supremes	Tamla Motown
We're Through	The Hollies	Parlophone
Walk Away	Matt Monro	Parlophone
Yes I Will	The Hollies	Parlophone
World Of Our Own	The Seekers	Columbia
Yeh Yeh	Georgie Fame	Columbia
You've Lost That Lovin' Feelin'	Cilla Black	Parlophone

**BEST SELLING L.P.s FROM E.M.I.
JUNE 1964 to JUNE 1965**

A Hard Day's Night	The Beatles	Parlophone
Aladdin	Cliff Richard	Columbia
Animal Tracks	The Animals	Columbia
Beatles For Sale	The Beatles	Parlophone
Cilla	Cilla Black	Parlophone
Collection Of Tamla Motown	Various Artists	Tamla Motown
Cliff Richard	Cliff Richard	Columbia
Dance With The Shadows	The Shadows	Columbia
Fame At Last	Georgie Fame	Columbia
Ferry Cross The Mersey	Gerry and the Pacemakers	Columbia
Goldfinger	Soundtrack	United Artists
Gene Pitney's Big 16	Gene Pitney	Stateside
Mary Poppins	Soundtrack	H.M.V.
Meet The Supremes	The Supremes	Tamla Motown
Please Please Me	The Beatles	Parlophone
Seven Faces Of Manfred Mann	Manfred Mann	H.M.V.
Spotlight On The Black And White Minstrels	Black & White Minstrels	H.M.V.
Unforgettable	Nat King Cole	Capitol
The Animals	The Animals	Columbia
Wonderful Life	Cliff Richard	Columbia

**BEST SELLING E.P.s FROM E.M.I.
JUNE 1964 to JUNE 1965**

All My Loving	The Beatles	Parlophone
A Hard Day's Night	The Beatles	Parlophone
A Hard Day's Night Vol: 2	The Beatles	Parlophone
Animals Is Here	The Animals	Columbia
Beatles For Sale	The Beatles	Parlophone
Beatles For Sale No: 2	The Beatles	Parlophone
Dynamic Shirley Bassey	Shirley Bassey	United Artists
Eine Kleine Beate Musik	Barock and Roll Ensemble	Parlophone
Four By The Beachboys	The Beach Boys	Capitol
Groovin' With Manfred Mann	Manfred Mann	H.M.V.
Long Tall Sally	The Beatles	Parlophone
Mrs. Brown You've Got A Lovely Daughter	Herman's Hermits	Columbia
Rhythm 'n Blues At The Flamingo	Georgie Fame	Columbia
Rhythm And Greens	The Shadows	Columbia
Twist And Shout	The Beatles	Parlophone
These Brilliant Shadows	The Shadows	Columbia
Themes From Aladdin	The Shadows	Columbia
Unforgettable	Nat King Cole	Capitol
Walkin' Alone	Richard Anthony	Columbia
Wonderful Life	Cliff Richard	Columbia

**WORLD WIDE MUSIC
TRADE DIRECTORY**

(Continued from page 5)

GOLUBOFF INDUSTRIAS FONOGRAFICAS S.A.—
Casilla 2471—SANTIAGO DE CHILE
(Miraflores 119—Santiago de Chile)
Phone: 381952, 392238, 461520
Cable: GODAV SANTIAGO CHILE
Pres.: Mr. Diego Goluboff S.
Labels (domestic): Vivart
Labels (others): CBS, Ricordi, Sono Radio.

INDUSTRIAS ELECTRICAS Y MUSICALES ODEON S.A.
Casilla 186-D—SANTIAGO DE CHILE
(Compañia 2045—Santiago de Chile)
Phone: 85565
Cable: TURNTABLE SANTIAGO CHILE
Man. Dir.: Mr. H. Epple
Labels (domestic): Odeon
Labels (others): Angel, Capitol, Columbia, Coral,
Decca, Electrola, His Master's Voice, London,
Musidisc, Nilser, Parlophone, Pathé, Warner Bros.

**ORPAL, EDITORA CHILENA DE DISCOS (PATIÑO Y
ORTIZ LTDA.)—**Casilla 6117—SANTIAGO DE CHILE
(Irarrazaval 3349—Santiago de Chile)
Pres.: Mr. Carlos Patiño Iturrieta & Mr. Leonidas R.
Ortiz Farías
Labels (domestic): Capait, Carrusel, L. R. Orpal
Labels (others): Calesita, Folkways, Microfón, Opus
Serenata, Surco, TK.

PHILIPS CHILENA S.A. DE PRODUCTOS ELECTRICOS
—Casilla 2687—SANTIAGO DE CHILE
(Avenida Santa Maria 0760—Santiago de Chile)
Phone: 35081/8
Cable: PHILCHISA SANTIAGO CHILE
Mgr. Record Dept.: Mr. Alain Trossat
Labels (domestic): Philips
Labels (others): ABC Paramount, Ansonia, Deutsche
Grammophon, Durium, Dusa, Fiesta, Gordy, Mag,
Mercury, M.G.M., Motown-Tamla, Peerless, Poly-
dor, Riverside, Seeco, United Artists, Virrey.

CHINA

EXPORT & IMPORT

GUOZI SHUJIAN, CHINA PUBLICATIONS CENTRE—
P.O. Box 399—PEKING
(Hsi Tan Building—Peking)
Cable: GUOZI PEKING
Mgr: Mr. Shao Kung-wen
Only organization to be contacted in questions of
export or import of ready-made cultural goods (rec-
ords and sheet music editions).

The
SYDNEY BRON
Group of companies in
LONDON

Sydney Bron Music Co. Ltd.
Yale Music Corporation Ltd.
Hit Songs Ltd.
Sheridan Music Co. Ltd.
Song Favourites Ltd.
B.V.F. Anglo-Continental Music
Co. Ltd.
Carrie Music Ltd.
Debmar Publishing Co. Ltd.

29-31 OXFORD STREET
LONDON, W.I. ENGLAND

Congratulations
from
CYRIL SHANE
and
THE STAFF

SHAPIRO BERNSTEIN
and Company Ltd.

WARWICK HOUSE
38, SOHO SQUARE
LONDON W.I. ENGLAND

Congratulations
from
LEN TAYLOR
of
BOURNE MUSIC LTD.

34-36 MADDOX STREET
LONDON W.1. ENGLAND
Telephone: HYD: 6412/6583
Cables: BOURNEMUSIC,
LONDON, W.I.

Congratulations
to **Cash Box**
from **CYRIL GEE**

Mills Music Ltd.
LONDON

and to their contract writers
Roger Greenaway
and
Roger Cook

for their hit song:
"You've Got Your Troubles"

20 DENMARK ST. LONDON. WC2

INTERNATIONAL REPRESENTATION

THROUGH

**THE BURLINGTON-PALACE
MUSIC GROUP**

BRITISH ISLES

BURLINGTON MUSIC CO. LTD. PALACE MUSIC CO. LTD.
9 Albert Embankment, and 9 Albert Embankment,
London, SE 1. London, SE 1.

U.S.A.

BURLINGTON MUSIC CORPORATION FELSTED MUSIC CORPORATION
539 West 25th Street and 539 West 25th Street
New York 1, N.Y. New York 1, N.Y.

CANADA

BURLINGTON MUSIC OF CANADA FELSTED MUSIC OF CANADA, LTD.
190 Graveline Road, LTD. and 190 Graveline Road,
St. Laurent, P.Q. St. Laurent, P.Q.

AUSTRALASIA

PALACE MUSIC (PTY) LIMITED
299-301, Castlereagh Street,
Sydney, N.S.W.

BENELUX COUNTRIES

N.V. PALACE MUSIC HOLLAND
Vondelstraat 90,
Amsterdam-W

SCANDINAVIA

PALACE MUSIC (SWEDEN) A.B.
Brahögatan 24,
Stockholm O.

ITALY

EDIZIONI MUSICALI PALACE Srl.
Piazzetta Pattari 2,
Milano.

SOUTH AFRICA

BURLINGTON MUSIC (AFRICA)
a division of:
MUSIC PUBLISHING CO. OF AFRICA
(PTY) LIMITED

161, President Street,
Johannesburg.

GERMANY & AUSTRIA

BURLINGTON MUSIKVERLAG GmbH.
Hoehenweg 22,
8211 Rimsting (Chiemsee),
Bavaria, Germany.

**FRANCE &
FRENCH UNION**

EDITIONS MUSICALES PALACE Sarl.
14, Avenue Hoche,
Paris VIII.

BEST SELLING SINGLES FROM PHILIPS

JUNE 1964 to JUNE 1965

Black Girl	The Four Pennies	Philips
Don't Bring Me Down	The Pretty Things	Fontana
Game Of Love	Wayne Fontana	Fontana
Hawaiian Wedding Song	Julie Rogers	Mercury
Honey I Need	The Pretty Things	Fontana
I Just Don't Know What To Do With Myself	Dusty Springfield	Philips
I Found Out The Hard Way	The Four Pennies	Philips
King Of The Road	Roger Miller	Philips
Like A Child	Julie Rogers	Mercury
Losing You	Dusty Springfield	Philips
Maybe I Know	Lesley Gore	Mercury
Rag Doll	The Four Seasons	Philips
Sweet William	Millie	Fontana
Um, Um, Um, Um, Um, Um	Wayne Fontana	Fontana
The Wedding	Julie Rogers	Mercury
Wishin' and Hopin'	The Merseybeats	Fontana

BEST SELLING L.P.s FROM PHILIPS

JUNE 1964 to JUNE 1965

A Girl Called Dusty	Dusty Springfield	Philips
It's Just A Matter Of Time	Brook Benton	Mercury
Joan Baez	Joan Baez	Fontana
Joan Baez In Concert	Joan Baez	Fontana
Joan Baez In Concert No: 2	Joan Baez	Fontana
Joan Baez No. 5	Joan Baez	Fontana
Jazz Sebastian Bach	Les Swingle Singers	Philips
Oscar Trio Plus One	Oscar Peterson	Mercury
Pretty Things	The Pretty Things	Fontana
Sing Bach, Handel & Vivaldi	Les Swingle Singers	Philips
Sacred Songs	Harry Secombe	Philips
Sound Of Julie	Julie Rogers	Mercury
Their First L.P.	Spencer Davis	Fontana
Um, Um, Um, Um, Um, Um	Wayne Fontana	Fontana

BEST SELLING E.P.s FROM PHILIPS

JUNE 1964 to JUNE 1965

Dusty	Dusty Springfield	Philips
Don't Think Twice	Joan Baez	Fontana
I Only Want To Be With You	Dusty Springfield	Philips
Julie	Julie Rogers	Mercury
Jazz Sebastian Bach	Les Swingle Singers	Philips
Once I Had A Sweetheart	Joan Baez	Fontana
The Pretty Things	The Pretty Things	Fontana
Passing Strangers	Sarah Vaughan & Billy Eckstein	Mercury
Pretty Boy Floyd	Joan Baez	Fontana
Silver Dagger	Joan Baez	Fontana
Um, Um, Um, Um, Um, Um	Wayne Fontana	Fontana

BEST SELLING E.P.'s FROM PYE

Bumble Bee	The Searchers	Pye
C'est Fab	Francois Hardy	Pye
Don't Make Me Over	Dionne Warwick	Pye
Francois Hardy Sings In English	Francois Hardy	Pye
Kinks Size Hits	The Kinks	Pye
Lawrence Of Arabia Vol: 1	Soundtrack	Pye
The Searchers Play The System	The Searchers	Pye
The Best Of Chuck Berry	Chuck Berry	Pye
There's Always Something There	Sandie Shaw	Pye
Kinks Size Session	The Kinks	Pye

BEST SELLING L.P.'s FROM PYE

Bonnie Scotland	The Alexander Brothers	Pye
Hello Dolly & 14 Other Big Hits	Kenny Ball	Pye
Francois Hardy	Francois Hardy	Pye
Highland Fling	The Alexander Brothers	Pye
Hancock	Tony Hancock	Pye
Kinks	The Kinks	Pye
Haste Ye Back	The Alexander Brothers	Pye
Kinda Kinks	The Kinks	Pye
Keely Smith Sings The Lennon/McCartney	Song Book	Reprise
It's The Searchers	The Searchers	Pye
Highland Fling	The Alexander Brothers	Pye
It Might As Well Be Swing	Frank Sinatra	Reprise
Lawrence Of Arabia	Soundtrack	Pye
Let's Have A Ceilidh	The Alexander Brothers	Pye
Make Way For Dionne Warwick	Dionne Warwick	Pye
More Junk From Steptoe & Son	Wilfred Bramble & Harry H. Corbett	Pye
Presenting Dionne Warwick	Dionne Warwick	Pye
Rhythm & Blues All Stars	Various Artistes	Pye
Rhythm And Blues	Various Artistes	Pye
Sounds Like The Searchers	The Searchers	Pye
Sandie	Sandie Shaw	Pye
The Hit Makers	Various Artistes	Pye
Tchaikovsky Double Pack	Trini Lopez	Pye
Trini Lopez At P.J.'s	Donovan	Reprise
What's Bin Did And What's Bin Hid		Pye

BEST SELLING SINGLES FROM PYE

JUNE 1964 to JUNE 1965

All Day And All Of The Night	The Kinks	Pye
All Over The World	Francois Hardy	Pye
Bread And Butter	The Newbeats	Hickory
Cast Your Fate To The Wind	So Unds Orchestral	Picadilly
Catch The Wind	Donovan	Pye
Colours	Donovan	Pye
Down Town	Petula Clark	Pye
Everybody Loves Somebody	Dean Martin	Reprise
Everybody's Gonna Be Happy	The Kinks	Pye
Funny How Love Can Be	The Ivy League	Picadilly
Girl Don't Come	Sandie Shaw	Pye
Goodbye My Love	The Searchers	Pye
Have I The Right	The Honeycombs	Pye
He's In Town	The Rockin' Berries	Pye
I'll Stop At Nothing	Sandie Shaw	Pye
I Know A Place	Petula Clark	Pye
Long Live Love	Sandie Shaw	Pye
Nobody's Child	The Alexander Brothers	Pye
Poor Man's Son	The Rockin' Berries	Pye
Remember Walkin' In The Sans	The Shangri-Las	Redbird
Set Me Free	The Kinks	Pye
There's Always Something There To Remind Me	Sandie Shaw	Pye
Someday We're Gonna Love Again	The Searchers	Pye
When You Walk In The Room	The Searchers	Pye
Where Are You Now	Jackie Trent	Pye
What Have They Done To The Rain	The Searchers	Pye
Tired Of Waiting	The Kinks	Pye
You Really Got Me	The Kinks	Pye
You're Breaking My Heart	Keeley Smith	Pye
You'll Never Get To Heaven	Dionne Warwick	Pye

**YOUR
CONTACT**

**FOR THE
WORLD
OUTSIDE U.S.A.**

**KEITH PROWSE
MUSIC PUBLISHING CO. LTD.
THE PETER MAURICE
MUSIC COMPANY LIMITED**

U. K. Companies &
Associates

Clinton Music Co.
Cooper Music Ltd.
Gallico Music Ltd.
Imperia Music Co.
K.P.M. Music Ltd.
Lois Music Ltd.
MacMelodies Ltd.
Marlboro Music Ltd.
Moss-Rose Music Ltd.
Reynolds Music
Sam Fox Publishing Co.
(London) Ltd.

Spanka Music Ltd.
Television Music Ltd.
The World Wide Music
Co. Ltd.
World Copyrights Ltd.
Foreign Companies
Edizioni Musicali
Peter Maurice (Milan)
Edition Excelsior
Hans Gerig (Cologne)
Editions Musicales
Peter Maurice (Paris)
Peter Maurice
Belgolux S.A. (Brussels)

21, DENMARK STREET, LONDON, W.C.2.

Telegrams & Cables: MAURITUNES, LONDON, W.C.2
Telephones: TEMPLE BAR 3856 (7 Lines)

BEST SELLING SINGLES FROM CBS

I Left My Heart In San Francisco	Tony Bennett	CBS
If I Ruled The World	Tony Bennett	CBS
It Ain't Me Babe	Johnny Cash	CBS
Maggie's Farm	Bob Dylan	CBS
Mr. Tambourine Man	The Byrds	CBS
Subterranean Homesick Blues	Bob Dylan	CBS
The Times They Are A-Changin'	Bob Dylan	CBS

BEST SELLING L.Ps FROM CBS

Almost There	Andy Williams	CBS
Another Side Of Bob Dylan	Bob Dylan	CBS
Bob Dylan	Bob Dylan	CBS
Bringing It All Back Home	Bob Dylan	CBS
Freewheelin'	Bob Dylan	CBS
My Fair Lady	Soundtrack	CBS
The Times They Are A-Changin'	Bob Dylan	CBS
West Side Story	Soundtrack	CBS

CASH BOX INTERNATIONAL AWARDS

GOLD

(Awarded to Non-American artistes reaching No. 1 in Cosh Box Top 100)

JANUARY 1963	THE TORNADOS	TELSTAR	CAPITOL
JUNE 1963	KYU SAKAMOTO	SUKIYAKI	PHILIPS
NOVEMBER 1963	THE SINGING NUN	DOMINIQUE	E.M.I.
FEBRUARY 1964	THE BEATLES	I WANT TO HOLD YOUR HAND	E.M.I.
MARCH 1964	THE BEATLES	SHE LOVES YOU	E.M.I.
MARCH 1964	THE BEATLES	TWIST AND SHOUT	E.M.I.
APRIL 1964	THE BEATLES	CAN'T BUY ME LOVE	E.M.I.
MAY 1964	THE BEATLES	LOVE ME DO	E.M.I.
JUNE 1964	PETER & GORDON	A WORLD WITHOUT LOVE	E.M.I.
JULY 1964	THE BEATLES	A HARD DAY'S NIGHT	E.M.I.
SEPTEMBER 1964	THE ANIMALS	HOUSE OF THE RISING SUN	E.M.I.
OCTOBER 1964	MANFRED MANN	DO WAH DIDDY DIDDY	DECCA
DECEMBER 1964	THE ZOMBIES	SHE'S NOT THERE	E.M.I.
JANUARY 1965	THE BEATLES	I FEEL FINE	PYE
JANUARY 1965	PETULA CLARK	DOWNTOWN	E.M.I.
MARCH 1965	THE BEATLES	EIGHT DAYS A WEEK	E.M.I.
APRIL 1965	HERMAN'S HERMITS	CAN'T YOU HEAR MY HEARTBEAT	E.M.I.
APRIL 1965	FREDDIE & THE DREAMERS	I'M TELLING YOU NOW	VOCEA
APRIL 1965	WAYNE FONTANA	GAME OF LOVE	PHILIPS
APRIL 1965	HERMAN'S HERMITS	MRS. BROWN YOU'VE GOT A LOVELY DAUGHTER	E.M.I.
MAY 1965	THE BEATLES	TICKET TO RIDE	E.M.I.
JULY 1965	SATISFACTION	THE ROLLING STONES	DECCA

SILVER

(Awarded to Non-American artistes reaching No. 2 to No. 20 in Cosh Box Top 100)

JULY 1963	ROLF HARRIS	TIE ME KANGAROO DOWN, SPORT	E.M.I.
DECEMBER 1963	THE CARAVELLES	YOU DON'T HAVE TO BE A BABY TO CRY	DECCA
MARCH 1964	THE BEATLES	PLEASE, PLEASE ME	E.M.I.
MAY 1964	THE BEATLES	DO YOU WANT TO KNOW A SECRET	E.M.I.
MAY 1964	DANNY WILLIAMS	WHITE ON WHITE	E.M.I.
MAY 1964	THE DAVE CLARK FIVE	BITS & PIECES	E.M.I.
MAY 1964	THE DAVE CLARK FIVE	GLAD ALL OVER	E.M.I.
MAY 1964	BILLY J. KRAMER	LITTLE CHILDREN	E.M.I.
JUNE 1964	THE BEATLES	P.S. I LOVE YOU	E.M.I.
JUNE 1964	THE DAVE CLARK FIVE	DO YOU LOVE ME	E.M.I.
JUNE 1964	THE BACHELORS	DIANE	DECCA
JULY 1964	GERRY & THE PACEMAKERS	DON'T LET THE SUN CATCH YOU CRYING	E.M.I.
JULY 1964	MILLIE (SMALL)	MY BOY LOLLIPOP	FONTANA
JULY 1964	BILLY J. KRAMER	BAD TO ME	E.M.I.
JULY 1964	DAVE CLARK FIVE	CAN'T YOU SEE THAT SHE'S MINE	E.M.I.
JULY 1964	DUSTY SPRINGFIELD	WISHIN' & HOPIN'	PHILIPS
JANUARY 1965	THE SEARCHERS	LOVE POTION NO. 9	PYE
APRIL 1965	PETULA CLARK	I KNOW A PLACE	PYE

SONG WRITERS — PUBLISHERS ! ! ! !

YOUR SONG ARRANGED — RECORDED AS DEMO DISC.
MUSIC COMPOSED FOR LYRICS IF REQUIRED.

CITY MUSIC 8 RADNOR HOUSE, 93-97 REGENT ST., LONDON, W1.

THE ROBERT MELLIN LTD.

GROUP OF COMPANIES

64, NEW BOND STREET,
LONDON W.1. ENGLAND

Telephone: MAYFAIR 3272.

Cables: MELLINMUS — LONDON

THE CAMPBELL CONNELLY

WORLD-WIDE GROUP OF COMPANIES

LONDON

ROY BERRY
10 DENMARK STREET
LONDON WC 2.

Branches in:-

NEW YORK • PARIS • HAMBURG
COPENHAGEN • AMSTERDAM • BUENOS AIRES
MILAN • BARCELONA • BRAZIL • SYDNEY
• JOHANNESBURG •

ENGLAND'S NEWEST & MOST PROGRESSIVE PUBLISHERS
and RECORD PRODUCERS

MILLWICK LTD.

IN ONE YEAR: MUSIC PUBLISHING CATALOGUE DEALS MADE ALL OVER THE
WORLD, FRANCE, GERMANY, SWEDEN, ITALY, U.S.A. & CANADA.

Artistes Independently Produced By Us Are Contracted
To Pye, Decca, HMV, RCA, ABC Paramount, Roulette, Etc.

TWO MUSICALS COMPLETED & NEGOTIATING PRODUCTION!
(WATCH THIS SEASON'S COMING ACTIVITIES)

"We believe that our team of writers will emerge
amongst the finest in the world."

MILLWICK LTD., Suite 15, 43 Upper Berkeley Street
London W.1. Amb: 0563/3588

President: LIONEL SEGAL
Gen. Man.: JACK HEATH

A HAPPY ANNIVERSARY

To Cash Box

from

NOEL ROGERS UNITED ARTISTS MUSIC LTD.

Film Music Successes Of The Year Include:

"GOLDFINGER"

"THE KNACK"

"WHAT'S NEW PUSSYCAT"

FLAT 5, ALBERTGATE COURT
125 KNIGHTSBRIDGE, LONDON, S.W.1.

BRITISH PRESSING PLANTS

ALLIED RECORDS LTD.
326, Kensal Road,
London, W.10.

BRITISH HOMOPHONE CO. LTD.
Excelsior Works,
Rollins Street,
London, S.E.15.

CBS RECORDS LTD.
Chamberlain Road, Aylesbury,
Buckinghamshire.

THE DECCA RECORD COMPANY LTD.
Albert Road, New Malden,
Surrey.

E.M.I. LTD.
Blyth Road, Hayes,
Middlesex.

ORLAKE LTD.
Sterling Works,
Rainham Road South, Dagenham,
Essex.

PHILIPS RECORDS LTD.
Record Works,
Walthamstow Avenue,
London, E.4.

THAMES VALLEY MOULDERS
Woolpact Lane, Braintree,
Essex.

TRANSCRIPTION MANUFACTURING &
RECORDING CO. LTD.
James Estate,
Western Road, Mitcham,
Surrey.

MELODISC RECORDS LTD

Specialists in:-

RHYTHM & BLUES
COUNTRY & WESTERN
FOLK MUSIC AND
JAZZ!

Would like to hear from
American Manufacturers
seeking outlets in the U.K.

12 EARLHAM STREET
LONDON. WC2 ENGLAND

ENGLAND — Music Publishers

AIRBORNE LTD.
26, D'Arbly Street,
London, W. 1.
Tel: Gerrard 3745

AMBASSADOR MUSIC LTD.
(Gil Music)
(George Pincus & Sons Music)
(In Music)
(Davon Music)
(Cash Songs Pub. Co.)
23-24, Greek Street,
London, W. 1.
Tel: Gerrard 7053

APEX MUSIC COMPANY
33, D'Arbly Street,
London, W. 1.
Tel: Mayfair 0686

APOLLO MUSIC LTD.
(Trelion Music Co. Ltd.)
(Solihull Music Ltd.)
(Forward Music Ltd.)
164, Shaftesbury Avenue,
London, W.C.2.
Tel: Temple Bar 0022

ARCADIA MUSIC PUBLISHING CO. LTD.
(Swan & Co. Ltd.)
(Polyphone Music Co. Ltd.)
10, Sherlock Mews,
London, W. 1.
Tel: Welback 5469

ANDESOUND
(Nanker Phelge Music Ltd.)
(Mirage Music Ltd.)
(Andes Music Ltd.)
(Immediate Music Incorporated)
138, Ivor Court,
Gloucester Place,
London, N.W.1.
Tel: Ambassador 1811

ARDMORE & BEECHWOOD, LTD.
(Black Swan Music)
(Coppa Music Ltd.)
(Harvard Music Ltd.)
(Hugreen Music Ltd.)
(Hunter Music Ltd.)
(Mutual Music Ltd.)
(Mulberry Music Ltd.)
(Genevieve Music Ltd.)
(Westside Music Ltd.)
(Pepe Music Ltd.)
(Newport Music Ltd.)
30-34, Langham Street,
London, W. 1.
Tel: Museum 6766

ASCHERBERG, HOPWOOD & CREWE LTD.
(Cary & Co. Ltd.)
(Bayley & Ferguson Ltd.)
16, Mortimer Street,
London, W. 1.
Tel: Museum 3562

EDWIN ASHDOWN LTD.
P.O. Box No. 4,
19, Hanover Square,
London, W. 1.
Tel: Mayfair 1184

**ASSOCIATED BOARD OF THE ROYAL
SCHOOL OF MUSIC**
14, Bedford Square,
London, W. C. 1.
Tel: Museum 3562

BELINDA (LONDON) LTD.
(Aberbach (London) Ltd.)
(Anita Music Ltd.)
(Belinda (London) Ltd.)
(Belinda Recordings Ltd.)
(Benday Music Ltd.)
(Cardinal Music Ltd.)
(Coronet Music Ltd.)
(December Music Ltd.)
(Design Music Ltd.)
(Enquiry Music Ltd.)
(Escort Music Ltd.)
(Festienne Music Ltd.)
(Fiesta Music Ltd.)
(Hill and Range Songs (Ldn) Ltd.)
(Jack Good Music Pub. Co. Ltd.)
(Joaneline Music Ltd.)
(Johnny Mathis Music Ltd.)
(June Music Ltd.)
(Kalith Music Ltd.)
(Kalman Music Ltd.)
(Kenmoss Music Ltd.)
(Kenny Lynch Music Ltd.)
(Kieron Music Ltd.)
(Knox Music Ltd.)
(Lark Music Ltd.)
(Lewman Music Ltd.)
(Linvoy Music Ltd.)
(Ludix Music Ltd.)
(Manor Music Co. Ltd.)
(Marlyn Music Co. Ltd.)
(Mayercroft Music Ltd.)
(Miranda Music Ltd.)
(Page Music Ltd.)
(Parkgate Music Ltd.)
(Pearl Harbor Music Ltd.)
(Peterman & Co. Ltd.)
(Progressive Music Ltd.)
(Quarter Music Ltd.)
(Riverdale Music Ltd.)
(Robert Vinton Music Ltd.)
(Roosevelt Music Ltd.)
(Scan Music Ltd.)
(Sea Lark Music Ltd.)
(Semprini Music Ltd.)
(Shadam Music Ltd.)
(Shadows Music Ltd.)
(Slamina Music Ltd.)
(Smooth Music Ltd.)
(S.P.R. Music Ltd.)
(Starfire Music Ltd.)
(Stork Music Pub. Co. Ltd.)
(T. M. Music Ltd.)
(Tollie Music Ltd.)
(Tone Music Ltd.)
(Vicki Music Ltd.)
(Vincent Shephard Enterprises Ltd.)
(West One Music Ltd.)

**BOOSEY & HAWKS MUSIC PUBLISHERS
LTD.**
(Anglo-Soviet Music Press Ltd.)
(Boosey & Co. Ltd.)
(Cavendish Music Co. Ltd.)
(Hawkes & Son (London) Ltd.)
(J. R. Lafleur & Son Ltd.)
(Rudall, Carte & Co. Ltd.)
(Winthrop Rogers)
295, Regent Street,
London, W. 1.
Tel: Langham 2060

BOSWORTH & CO. LTD.
14-18, Heddon Street,
London, W. 1.
Tel: Regent 4961/2

BOURNE MUSIC LTD.
(Aeolian Music Ltd.)
34-36, Maddox Street,
London, W. 1.
Tel: Hyde Park 6412/6583

BOX & COX (PUBLICATIONS) LTD.
(Bocu Music Ltd.)
(Mello Music Ltd.)
7, Denmark Street,
London, W. C. 2.
Tel: Temple Bar 8969

BRON ASSOCIATED PUBLISHERS LTD.
(B.V.F. Anglo-Continental Music Co. Ltd.)
(Bron Music Co. Ltd.)
(Carrie Music Ltd.)
(Debmar Publishing Co. Ltd.)
(Hit Songs Ltd.)
(A. Schroeder Music Pub. Co. Ltd.)
(Sheridan Music Co. Ltd.)
(Song Favourites Ltd.)
(Yale Music Corporation Ltd.)
29-31, Oxford Street,
London, W. 1.
Tel: Gerrard 5063

BURLINGTON MUSIC CO. LTD.
(Palace Music Co. Ltd.)
9, Albert Embankment,
London, S. E. 1.
Tel: Reliance 2692 and Malden 7507

TONY CALDER MUSIC
147, Ivor Court,
Gloucester Place,
London, N.W.1.
Tel: Ambassador 2701

THE CAMPBELL CONNELLY GROUP
(Berry Music Co. Ltd.)
(Cinephonic Music Co. Ltd.)
(Cross Music Ltd.)
(Dash Music Co. Ltd.)
(Evergreen Music Co. Ltd.)
(High-Fye Music Ltd.)
(Vy Music Ltd.)
(Montclare Music Co. Ltd.)
(Hans Sikorski Ltd.)
(Harrison Music Co. Ltd.)
(Robroy Music Ltd.)
(Starlite Music Publishing Co. Ltd.)
10, Denmark Street,
London, W. C. 2.
Tel: Temple Bar 1653

CHACKSFIELD MUSIC LTD.
(Eros)
(Medway)
"Allegro"
Elm Walk,
Farnborough,
Kent.
Tel: Farnborough 55509

CHAPPELL & CO. LTD.
(Acuff-Rose Publications Ltd.)
(Larry Adler Music Ltd.)
(Avenue Music Pub. Co. Ltd.)
(Belafonte Music Ltd.)
(Britannia Music Co. Ltd.)
(Irving Berlin Ltd.)
(Bradbury Wood Ltd.)
(Bregman, Voeco & Conn Ltd.)
(Clarence Music Ltd.)
(Compass Music Ltd.)
(Commair Chappell Ltd.)
(Walt Disney Music Co. Ltd.)
(Delfont Music Ltd.)
(E.F.D.S. Publications Ltd.)
(Erle Music Ltd.)
(Fairway Music Ltd.)
(Famous-Chappell Ltd.)
(Frank Music Co. Ltd.)
(Gallahad Music Ltd.)
(Intertel Music Co. Ltd.)
(Jewel Music Pub. Co. Ltd.)
(Maddox Music Co. Ltd.)
(Michele Music Ltd.)
(Minstrel Music Ltd.)
(New World Publishers Ltd.)
(Paxwin Music Ltd.)
(Sheldon Music Ltd.)
(Sterling Music Pub. Co. Ltd.)
(Springfield Music Ltd.)
(Stratford Music Ltd.)
(Travis Music Ltd.)
(Valando Music Ltd.)
(Victoria Music Pub. Co. Ltd.)
(P. K. Music Ltd.)
(Planetary-Nom London Ltd.)
(Walton Music Ltd.)
(Williamson Music Ltd.)
(Ben Selvin Music Ltd.)
(Edwin H. Morris & Co. Ltd.)
50, New Bond Street,
London, W. 1.
Tel: Mayfair 7600

J. & W. CHESTER LTD.
11, Great Marlborough Street,
London, W. 1.
Tel: Gerrard 9546

EDWARD COX MUSIC CO. LTD.
142, Charing Cross Road,
London, W. C. 2.
Tel: Temple Bar 3917

J. B. CRAMER & CO. LTD.
139, New Bond Street,
London, W. 1.
Tel: Mayfair 3456

CRANZ & CO. LTD.
1, Montague Street,
London, W. 1.
Tel: Avenue 4266

DANVER MUSIC LTD.
(Joper Music Ltd.)
16, Soho Square,
London, W. 1.
Tel: Gerrard 4898

DOUGLAS MUSIC COMPANY
(Anglia Music)
18, Broadlands Avenue,
Streatham,
S. W. 16.
Tel: Streatham 1437

DUNRAVEN MUSIC PUBLISHING CO. LTD.
28/30, Market Place,
London, W. 1.
Tel: Langham 9694

ESSEX MUSIC LTD.
(Allegro Music Ltd.)
(Coda Music Ltd.)
(Concord Music Ltd.)
(Cromwell Music Ltd.)
(Cynara Music Ltd.)
(Greenwich Music Ltd.)
(Harmony Music Ltd.)
(Horizon Music Ltd.)
(Jazz Music Ltd.)
(Kensington Music Ltd.)
(Key Music Ltd.)
(Lakeview Music Pub. Co. Ltd.)
(Majestic Music Ltd.)
(Musical Comedy Productions Ltd.)
(Romney Music Ltd.)
(Tyler Music Ltd.)
4, Denmark Street,
London, W. 1.
Tel: Covent Garden 1024

B. FELDMAN & CO. LTD.
(Dix Music Ltd.)
(British and Continental Music Agencies
Ltd.)
(Henrees Music Ltd.)
(Gerrard Music Ltd.)
(Kennedy Street Music Ltd.)
(Roar Music Ltd.)
(Hermusic Ltd.)
(Dreamers Music Ltd.)
64, Dear Street,
London, W. 1.
Tel: Gerrard 9336

JOHN FIELDS MUSIC CO. LTD.
(Dorsey Bros. Music Ltd.)
(King Jingle Ltd.)
(Phoenix Music Publishing Co. Ltd.)
(Primrose Music Co. Ltd.)
(Roncom Music Ltd.)
63a, Frith Street,
London, W. 1.
Tel: Regent 7462-3

FILMUSIC PUBLISHING CO. LTD.
(Pall Mall Music)
110, New Bond Street,
London, W. 1.
Tel: Hyde Park 7633

FLORIDA MUSIC COMPANY LTD.
(Angel Music Co.)
(Ember Mood Music Library)
(Gloucester Music Pub. Co.)
(Mark Music Pub. Co.)
(Monshana Music Publ. Co.)
(Mistropole Music Publ. Co.)
(Mood Music Publ. Co.)
(Sharon Music Pub. Co.)
York House,
Empire Way,
Tel: Diligence 1077
Wembley, Middlesex.

FLAMINGO MUSIC LTD.
Stanhope House,
Stanhope Place,
Tel: Ambassador 7788
London, W. 2.

FRANCIS DAY & HUNTER LTD.
138-140, Charing Cross Road,
London, W. C. 2.
Tel: Temple Bar 9351

FURSTNER LTD.
40, Hyde Park Gate,
Flat 6,
London, S.W. 7.
Tel: Kensington 4383

GALLIARD LTD.
(Augener Ltd.)
(Joseph Williams Ltd.)
(Weeks Music Ltd.)
148, Charing Cross Road,
London, W. C. 2.
Tel: Temple Bar 9364

NOEL GAY MUSIC CO. LTD.
(Clover-Conway Music Co. Ltd.)
(Felicia Gay Music Co. Ltd.)
(P & G Music)
(Plantagenet Music Co. Ltd.)
24, Denmark Street,
London, W. C. 2.
Tel: Temple Bar 3941

HEATHSIDE MUSIC
120/122, Marylebone Lane,
London, W. 1.
Tel: Hunter 4353

DICK JAMES MUSIC LTD.
(Lords Music Co. Ltd.)
(Northern Songs Ltd.)
(Jaep Music Ltd.)
(Pacermusic Ltd.)
(Metric Music Ltd.)
(Melcher Music Ltd.)
James House,
71/75, New Oxford Street,
London, W. C. 1.
Tel: Temple Bar 1687

KASSNER ASSOCIATED PUBLISHERS LTD.
(Bens Music Ltd.)
(City Music Ltd.)
(Coslow-Kassner Music Ltd.)
(Cumberland Music Ltd.)
(Denmark Productions Ltd.)
(Grosvenor Music Co. Ltd.)
(Gale & Gayles Ltd.)
(Edward Kassner Music Co. Ltd.)
(Cecil Lennox Ltd.)
(Myers Music Ltd.)
(J. Norris Music Pub. Co. Ltd.)
(Rush Music Ltd.)
(Success Music Ltd.)

(Schaeffers-Kassner Music Ltd.)
(Unit Productions Ltd.)
(Success Music Ltd.)
Kassner House,
25, Denmark Street,
London, W. C. 2.
Tel: Covent Garden 3026

K.P.M. MUSIC LTD.
(Budd Music Ltd.)
(Cooper Music Ltd.)
(Clinton Music Co.)
(Sam Fox Publishing Co. Ltd.)
(Gallico Music Ltd.)
(Gramito Music Ltd.)
(Imperia Music Co. Ltd.)
(Keith Prwose Music Publishing Co. Ltd.)
(Lois Music Ltd.)
(Maemelodies Ltd.)
(Marlboro Music Ltd.)
(Peter Maurice Music Co. Ltd.)
(Musicville Ltd.)
(Moss Rose Music Ltd.)
(Reynolds & Co. (Music Publishers) Ltd.)
(Spanka Music Ltd.)
(Television Music Ltd.)
(World Copyrights Ltd.)
(World Wide Music Co. Ltd.)
21, Denmark Street,
London, W. C. 2.
Tel: Temple Bar 3856

LEEDS MUSIC LTD.
(Blossom Music Ltd.)
(Challenge Music Ltd.)
(Cricket Music Ltd.)
(Duchess Music Ltd.)
(Elstree Music Ltd.)
(Eugene Music Ltd.)
(Harms-Witmark Ltd.)
(Joy Music Ltd.)
(Kags Music Ltd.)
(Maxana Music Ltd.)
(Pickwick Music Ltd.)
(South Mountain Music Ltd.)
(Spoon Music Ltd.)
(Tangerine Music Ltd.)
(Welbeck Music Ltd.)
25, Denmark Street,
London, W. C. 2.
Tel: Covent Garden 2962

LORNA MUSIC CO. LTD.
(Cinderella Music Ltd.)
(Charlie Parker Music Co. Ltd.)
(King Music Co. Ltd.)
(Speedee Music Ltd.)
(Woodside Music Ltd.)
5, Denmark Street,
London, W. C. 2.
Tel: Temple Bar 4741/2

LYNN MUSIC CO. LTD.
142, Charing Cross Road,
London, W. C. 2.
Tel: Temple Bar 0827

MAESTRO MUSIC
7/8, Norfolk Street,
Strand, W. C. 2.
Tel: Temple Bar 8570

MARQUIS MUSIC CO. LTD.
(Marquis Enterprises Ltd.)
(Mistletoe Melodies Ltd.)
(Verulam Music Co. Ltd.)
37, Soho Square,
London, W. 1.
Tel: Gerrard 9405

MEDIANT MUSIC LTD.
(Active Music Ltd.)
(Audio Ads Ltd.)
(Douglas Music Ltd.)
(Everest Music Ltd.)
(Peak Music Ltd.)
(Pop Music Ltd.)
(Matchless Music Ltd.)
(Movie Music Ltd.)
(Viking Music Ltd.)
30, Old Compton Street,
London, W. 1.
Tel: Gerrard 4938

ROBERT MELLIN LTD.
(Barton Music Co. Ltd.)
(Franco-London Music Ltd.)
(Harriet Music Ltd.)
(Lloyd Logan Ltd.)
(Monarch Music Ltd.)
(Nevins-Kirshner Music Ltd.)
(Sherwin Music Co.)
64, New Bond Street,
London, W. 1.
Tel: Mayfair 3272

MERIT MUSIC CO. LTD.
(Crescent Music Co.)
(London Northern Music Co.)
(Manette Music Ltd.)
(M. LeGrand Music Co. Ltd.)
47, Dean Street,
London, W. 1.
Tel: Regent 7451

MILLS MUSIC LTD.
(Henderson Music Co.)
(B. F. Wood Music Co. Ltd.)
20, Denmark Street,
London, W. C. 2.
Tel: Covent Garden 1745

MILLWICK LTD.
Suite 15,
43, Upper Berkeley Street,
London, W. 1.
Tel: Ambassador 0563/3588

MUSICALL PUBLISHERS LTD.
136, Fellows Road,
London, N.W.3.
Tel: Primrose 9027

MUSICUS LTD.
(Moon Music Ltd.)
47, Dean Street,
London, W. 1.
Tel: Gerrard 5708

NOVELLO & CO. LTD.
(Elkin & Co. Ltd.)
Borough Green,
Sevenoaks, Kent.
Tel: Seven Oakes 3261
London Showroom:
27, Soho Square, W. 1.
Tel: Gerrard 1222

SCOTT-SOLOMON PRODUCTIONS LTD.

71-75, New Oxford Street, London, W.C.1.

BRITAIN'S YOUNGEST & BRIGHTEST RECORD PRODUCTION COMPANY UNDER THE PERSONAL SUPERVISION OF: TOMMY SCOTT AND PHILIP SOLOMON

WORLD WIDE RECORD RELEASES:

"TERRY"
"GOLDEN LIGHTS"
"TOMMY"
RECORDED BY **TWINKLE**
(DECCA—U.K. VEE JAY—U.S.A.)

"BABY PLEASE DON'T GO"
"HERE COMES THE NIGHT"
"ONE MORE TIME"
"GLORIA"
RECORDED BY **THEM**
(DECCA—U.K. LONDON—U.S.A.)

"I WOULDN'T TRADE YOU FOR THE WORLD"
"NO ARMS CAN EVER HOLD YOU"
"TRUE LOVE FOR EVERMORE"
"MARIE"

ALL RECORDED BY
THE BACHELORS
UNDER SUPERVISION OF
DICK ROWE, DECCA RECORDS
(DECCA—U.K. LONDON—U.S.A.)

RECORDING

PUBLISHING

PROMOTION

AGENCY-MANAGEMENT

THE PHILIP SOLOMON ORGANIZATION

142 GROUP OF COMPANIES

ANGLO IRISH ARTISTES LTD.
BELGRAVIA MUSIC CO. LTD.
FAVOURITE MUSIC CO. LTD.
HYDE PARK MUSIC CO. LTD.
JASOL MUSIC LTD.
PAGSOL MUSIC LTD.

are under the personal supervision of:

PHILIP R. SOLOMON
71-75, NEW OXFORD STREET, LONDON, W. C. 1.
TEMPLE BAR 1801

NEW YORK COMPANY

BERNICE MUSIC
(BMI)

c/o WALTER HOFER
221, WEST 57th STREET,
NEW YORK
U.S.A.

**COLLINS,
SOLOMON
ASSOCIATES
LIMITED**

TOP P.R. COMPANY
IN THE U.K.
FULL COVERAGE ON PRESS P.A.
RADIO AND T.V.

and announcing:

MYRNA MALINSKY ASSOCIATES LTD.
(OUR THEATRE/DRAMA ETC. SIDE OF THE BUSINESS)

under the personal supervision of:

MISS MYRNA MALINSKY
(LATE CHIEF BOOKER FOR A.B.C. TELEVISION LONDON)
58, WARDOUR STREET, LONDON, W. 1. TEL: GERRARD 2045

**DOROTHY
SOLOMON
ASSOCIATED
ARTISTES LTD.**

AGENT & MANAGER
FOR
BRITAIN'S TOP T.V. AND
RECORDING STARS

**THE BACHELORS • THEM
TWINKLE
THE WHEELS • DOROTHY SQUIRES**

71-75, NEW OXFORD STREET,
LONDON, W.1. ENGLAND
TEL: TEMPLE BAR 1801/5

JUNE 1964 To JUNE 1965

Title	Artiste	British Publisher	American Publisher	British Label	American Label
A World Of Our Own	The Seekers	Springfield	Chappell	Columbia	Capitol
Anyways You Want It	Dave Clark	Ivy	Branston	Columbia	Epic
As Tears Go By	Marianne Faithfull	Forward	Essex	Decca	London
All Day And All Of The Night	The Kinks	Kassner	Jayboy	Pye	Reprise
Ain't She Sweet	The Beatles	Lawrence Wright	Advance	Parlophone	Atco
And I Love Her	George Martin	Northern Songs	Maclen-Unart	Parlophone	U.A.
*All Cried Out	Dusty Springfield	142 Music	Philips	Parlophone	Philips
A Summer Song	Chad And Jeremy	Rogers	Unart	Ember	World Artists
*Because	Dave Clark	Ivy	Ivy	Columbia	Epic
*Boom Boom	The Animals	142 Music	Conrad	Columbia	M.G.M.
*Bumble Bee	The Searchers	Twangy	Malati	Pye	Kapp
Baby Please Don't Go	Them	Leeds	Leeds	Decca	Parrott
*Bring It On Home To Me	The Animals	Kags	Kags	Columbia	M.G.M.
*Before And After	Chad And Jeremy	Sparta	Blackwood	CBS	Columbia
Cara Mia	Jay And The Americans	Robbins	Leo Feist	United Artists	U.A.
Catch The Wind	Donovan	Southern	Southern	Pye	Hickory
Concrete And Clay	Unit Four Plus Two	Apollo	Saturday	Decca	London
Can't You Hear My Heartbeat	Eddie Rambeau				Dynavoice
Come Home	Herman's Hermits	Southern	Southern	Columbia	M.G.M.
*Come Tomorrow	Dave Clark	Ivy	Branston	Columbia	Epic
*Come And Stay With Me	Manfred Mann	Belinda	Norma & Sylvia	HMV	Ascot
*Cast Your Fate To The Wind	Marianne Faithfull	Metric	Metric	Decca	London
*Do Wah Diddy Diddy	Sounds Orchestral	Mellin	Friendship	Piccadilly	Parkway
*Do The Freddie	Manfred Mann	West One	Trio	HMV	Ascot
Downtown	Freddie & The Dreamers		Dayshel	Columbia	Mercury
*Don't Let Me Be Misunderstood	Petula Clark	Welbeck	Leeds	Pye	Warner Bros.
Eight Days A Week	The Animals	West One	Benjamin	Columbia	MGM
From A Window	The Beatles	Northern Songs	Maclen	Parlophone	Capitol
Forget Domani	Billy J. Kramer	Northern Songs	Northern Ltd.	Parlophone	Imperial
From The Bottom Of My Heart	Chad And Jeremy			Ember	World Artists
For Your Love	Frank Sinatra	Robbins	Miller	Reprise	Reprise
Ferry Cross The Mersey	Connie Francis			MGM	MGM
For Mama	The Moody Blues	Sparta	Cheshire	Decca	London
Gonna Send You Back To Walker	The Yardbirds	Her Music	Blackwood	Columbia	Epic
*Goodbye My Love Goodbye	Gerry & The Pacemakers	Pacer	Unart Pacer	Columbia	Laurie
Gloria	Connie Francis	Essex	Ludlow	MGM	MGM
Goldfinger	The Animals	Mellin	Zann	Columbia	MGM
*Go Now	The Searchers	Schroeder	Sealark	Pye	Kapp
Girl Don't Come	Them	Hyde Park	Hyde Park	Decca	Parrott
*Game Of Love	Shirley Bassey	United Artists	Unart	United Artists	U.A.
Have I The Right	John Barry			United Artists	U.A.
He Won't Ask Me	The Moody Blues	Sparta	Trio	Decca	London
House Of The Rising Sun	Sandie Shaw	Glissando	Spectorious	Pye	Reprise
*Here Comes The Night	Wayne Fontana	Skidmore	Skidmore	Fontana	Fontana
Heart Of Stone	The Honeycombs	Ivy	Ivy	Pye	Interphon
I Feel Fine	Cilla Black	Jaep	Jaep	Parlophone	Capitol
I'm Gonna Love You Too	The Animals	Keith Prowse	Al Gallico	Columbia	Capitol
I Should Have Known Better	Them	Mellin	Keach Caesar & Dino	Decca	MGM
I'll Keep You Satisfied	The Rolling Stones	Northern Songs	Immediate	Decca	London
I'll Cry Instead	The Beatles	Southern	Maclen	Parlophone	Capitol
I'm Happy Just To Dance With You	The Hullabaloes	Northern Songs	Nor-Va-Jac	Columbia	Roulette
*I Wouldn't Trade You For The World	The Beatles	Northern Songs	Unart-Maclen	Parlophone	Capitol
I Like It	Billy J. Kramer	Northern Songs	Metric	Parlophone	Imperial
*I'm Into Something Good	The Beatles	Northern Songs	Unart-Maclen	Parlophone	Capitol
*I Don't Want To See You Again	The Beatles	Northern Songs	Unart-Maclen	Parlophone	Capitol
I'm Crying	The Bachelors	142 Music	LeBill	Decca	Capitol
Is It True	Gerry & The Pacemakers	Dick James	Gil	Columbia	London
If I Fell	Herman's Hermits	Screen Gems	Screen Gems	Columbia	Laurie
It's Gotta Last Forever	Peter & Gordon		Maclen	Columbia	MGM
*If I Loved Lou	The Animals		Al Gallico	Columbia	Capitol
If I Ruled The World	Brenda Lee	Southern	Southern	Brunswick	Decca
I Can't Explain	The Beatles	Northern Songs	Unar-Maclen	Parlophone	Capitol
I Don't Want To Spoil The Party	Billy J. Kramer	Belinda	Lynch Big Top	Parlophone	Imperial
I'm Telling You Now	Chad & Jeremy	Chappell	Chappell	CBS	Columbia
I Know A Place	Tony Bennett	Essex	Champion	Brunswick	Decca
*I Understand	The Who	Northern Songs	Maclen	Parlophone	Capitol
I'll Never Find Another You	The Beatles	Feldman	Miller	Columbia	Tower
*It's Not Unusual	Freddie & The Dreamers	Welbeck	Duchess	Pye	Warner Bros.
It's Gonna Be Alright	Freddie & The Dreamers	Maddox	Jubilee	Columbia	Mercury
*I'll Be There	The Seekers	Springfield	Springfield	Decca	Capitol
I Can't Stop	Tom Jones	Leeds	Duchess	Decca	Parrott
*I Go To Pieces	Gerry & The Pacemakers	Pacer	Pacemaker & Unart	Columbia	Laurie
It's All Right	Gerry & The Pacemakers	T.S. Music	T.M.		
*I Like It Like That	The Honeycombs	Ivy	Ivy	Pye	Interphon
James Bond Theme	Peter & Gordon		Vicki	Columbia	Capitol
*Love Potion No. 9	Adam Faith	Glissando	McLaughlin		
*Like A Child	Dave Clark		Andrews	Parlophone	Amy
Losing You	Billy Strange	United Artists	Tune Kel	Columbia	Epic
*Live It Up	The Searchers	Belinda	Unart		Crescendo
Little Lonely One	Julie Rogers	Shapiro Bernstein	Quintet	Pye	Kapp
Long Live Love	Dusty Springfield	Springfield	Ponderosa	Mercury	Mercury
*Matchbox	Dusty Springfield		Springfield	Philips	Philips
Mrs. Brown You've Got a Lovely Daughter	Tom Jones		Merjoda	Philips	Philips
*Marie	Sandie Shaw	Glissando	We Three	Decca	Tower
*No Arms Can Ever Hold You	The Beatles	Aberbach	Rosehill	Pye	Reprise
Ringo's Theme	The Beatles	Hermits Good	Knox	Parlophone	Capitol
'Reelin' And Rockin'	George Martin	F.D. & H.	Brackenbury	Columbia	MGM
She's A Woman	Dave Clark	Burlington	Hill & Range		
She's Not There	George Martin	Gil	Berlin	Decca	London
*Shout	Dave Clark	Unart-Maclen	Unart-Maclen	Decca	London
*Sweet William	The Beatles	Arc	Maclen	Parlophone	Capitol
*Someone Someone	The Zombies	Northern	Gallico	Decca	Epic
Someday We're Gonna Love Again	Lulu	Marquis	Wemar, Nom	Decca	Parrott
Slow Down	Millie	Weiner	Budd	Fontana	Smash
*Sha La La	Brian Poole & The Tremeloes	Burlington	Nep	Decca	Monument
Softly As I Leave You	The Searchers	Toby	McLaughlin	Pye	Kapp
*Silhouettes	The Beatles	Essex	Progressive	Parlophone	Capitol
She's Coming Home	The Beatles	Belinda	Ludig Flomarlu	HMV	Ascot
Set Me Free	Manfred Mann	Robbins	Miller	Reprise	Reprise
Satisfaction	Frank Sinatra	F.D. & H.	Regent	Columbia	MGM
*This Is On My Side	Herman's Hermits	Verulam	Mainstay	Decca	Parrott
There's Always Something There To Remind Me	The Zombies	Kassner	AM Enterprises	Pye	Reprise
Tobacco Road	The Rolling Stones	Mirage	Decca	Immediate	London
The Wedding	The Rolling Stones	Essex	Rittenhouse-Maygar	Decca	London
Tell Her No	Sandie Shaw	December	Jungnickel-Blue	Pye	Reprise
This Sporting Life	The Nashville Teens	Southern	Cedarwood	Decca	London
Tired Of Waiting For You	Julie Rogers	Peter Maurice	Bendig-Regent	Mercury	Mercury
The Last Time	The Zombies	Verulam	Mainstay	Decca	Parrott
*The Minute You're Gone	Ian Whitcomb	Sparta	Budette	Capitol	Tower
*True Love Ways	The Kinks	Kassner	Jayboy	Pye	Reprise
Ticket To Ride	The Rolling Stones	Mirage	Immediate	Decca	London
Talk About Love	Cliff Richard	Columbia	Jewel	Columbia	Epic
You Turn Me On	Peter & Gordon	Southern	Nor-Va-Jak	Columbia	Capitol
*This Little Bird	The Beatles	Northern Songs	Maclen	Parlophone	Capitol
*Trains & Boats & Planes	Adam Faith	Glissando	Rosehill	Parlophone	Amy
You Really Got Me	Ian Whitcomb	Sparta	Burdette	Capitol	Tower
*When You Walk In The Room	Marianne Faithfull	Acuff Rose	Acuff Rose	Decca	London
Walk Away	Billy J. Kramer	17 Savile Row	Blue Seas	Parlophone	Imperial
*Willow Weep For Me	The Kinks	Kassner	Kassner	Pye	Reprise
*What Have They Done To The Rain	The Searchers	Metric	Metric	Pye	Kapp
*What Do You Want With Me	Matt Monro	Ardmore & Beechwood	Ardmore & Beechwood	Parlophone	Liberty
*Wonderful World	Chad & Jeremy	F.D. & H.	Bourne	United Artists	World Artists
*What's New Pussy Cat	The Searchers	Essex	Schroeder	Pye	Kapp
*Yeh Yeh	Chad & Jeremy	Belinda	W.A. A.	Ember	World Artists
You Were Made For Me	Herman's Hermits	Ardmore Beechwood	Kags	Columbia	MGM
*You'll Never Walk Alone	Tom Jones	United Artists	United Artists	Decca	Parrott
	Georgie Fame	Feldman	Mongo	Columbia	Imperial
	Freddie & The Dreamers	Feldman	Marks	Columbia	Tower
	Gerry & The Pacemakers	Chappell	Harms	Columbia	Laurie

THE ARDMORE AND BEECHWOOD

GROUP OF COMPANIES

ARE

INTERNATIONALLY

AT YOUR SERVICE

IN THE FOLLOWING

TERRITORIES:—

ARGENTINE

Editorial Musical Odeon

AUSTRALIA

Castle Music Pty Ltd.

BENELUX

S.A. Ardmore & Beechwood

DENMARK

Musikforlaget Imudico A.S.

FRANCE

Les Editions Pathe-Marconi

GERMANY

Editions Accord

GT. BRITAIN

Ardmore & Beechwood Ltd. and Associated Companies

GREECE

Arion of Athens

ITALY

La Voce Del Padrone

JAPAN

Toshiba Music Pub. Ltd.

MEXICO

Brambila Musical S.A.

SOUTH AFRICA

Ardmore & Beechwood

SPAIN

Ediciones Gramofono-Odeon

SWEDEN

Editions Odeon

30-34, LANGHAM STREET LONDON. W.1. ENGLAND Telephone: MUSEUM-6766 Cables: BEECHMORE-LONDON

ENGLAND - Music Publishers

(Continued from page 26)

HAPIRO BERNSTEIN & CO. LTD.

(Glad Music Ltd.)
(Skidmore Music Ltd.)
(Twangy Music Ltd.)

3, Soho Square,
London, W. 1.
Tel: Gerrard 3493/4/5

HAMES MUSIC LTD.

1/41, New Bond Street,
London, W. 1.
Tel: Grosvenor 5961

OBY MUSIC LTD.

1, Vere Street,
London, W. 1.
Tel: Grosvenor 2791

AVID TOFF MUSIC PUBLISHING CO. LTD.

(Celestial Music Co. Ltd.)
(Era Music Co. Ltd.)
(Mansion Music Publications)

(Plaza Music Pub. Co.)
1, Newman Street,
London, W. 1.
Tel: Langham 0641

ONECOLOR LTD.

1, Newman Street,
London, W. 1.
Tel: Langham 3479

UNITED MUSIC PUBLISHING LTD.

1, Montague Street,
Russell Square,
London, W. C. 1.
Tel: Museum 5171

UNITED ARTISTES MUSIC LTD.

(Dominion Music Co. Ltd.)
(Parnes Music Ltd.)
(Soho Music Ltd.)
(Rogers Music Ltd.)

1, Albert Gate Court,
24, Knightsbridge,
London, S.W. 1.
Tel: Knightsbridge 9383

UNIVERSAL EDITION (LONDON) LTD.

(Alfred A. Kalmus Ltd.)
1/3, Fareham Street,
London, W. 1.
Tel: Gerrard 5203

PETER WALSH MUSIC LTD.

(Petford Music Ltd.)
(Tremeloes Music Ltd.)
(Wilmington Music Ltd.)

1, Kingsway,
London, W. C. 2.
Tel: Temple Bar 3611

JOSEPH WEINBERGER LTD.

(Glocken Verlag Ltd.)
(Inter-Art Music Publishers)

3, Crawford Street,
London, W. 1.
Tel: Paddington 6752

LAWRENCE WRIGHT MUSIC CO. LTD.

(Vocable Music Co. Ltd.)
9, Denmark Street,
London, W. C. 2.
Tel: Temple Bar 2141

ONE FOUR TWO MUSIC LTD.

(Belgravia Music Co. Ltd.)
(Anglo Irish Artistes Ltd.)
(Favourite Music Co. Ltd.)
(Hyde Park Music Co. Ltd.)
(Jasol Music Ltd.)
(Pagsol Music Ltd.)
(Tin Pan Alley Music Ltd.)

3-75, New Oxford Street,
London, W. C. 1.
Tel: Temple Bar 1801

OXFORD UNIVERSITY PRESS

14, Conduit Street,
London, W. 1.
Tel: Regent 5364

ORBIT UNIVERSAL MUSIC CO.

34, Greek Street,
London, W. 1.
Tel: Regent 2148

PAN-MUSIK LTD.

(Contact Music Ltd.)
(Disc Music Ltd.)

22, Denmark Street,
London, W. C. 2.
Tel: Covent Garden 2816

PEERS MUSIC LTD.

6, Denmark Place,
London, W. C. 2.
Tel: Covent Garden 0891

FREDDIE POSER MUSIC LTD.

(Blue Blood Music Ltd.)
(Glissando Music Ltd.)
(Marvel Music Ltd.)

46, Maddox Street,
London, W. 1.
Tel: Mayfair 1736

MICHAEL REINE MUSIC CO. LTD.

22, Denmark Street,
London, W.C.2.
Tel: Temple Bar 1456

G. RICORDI (LONDON) LTD.

271, Regent Street,
London, W. 1.
Tel: Mayfair 6518

ROBBINS MUSIC CORPORATION

(Leo Feist Ltd.)
23, Denmark Street,
London, W. C. 2.
Tel: Temple Bar 4685

SCHAUER & MAY

239, Shaftesbury Avenue,
London, W.C.2.
Tel: Temple Bar 3349

SCHOTT & CO. LTD.

48, Great Marlborough Street,
London, W. 1.
Tel: Gerrard 1246/7/8

SCREEN GEMS COLUMBIA MUSIC LTD.

(Colgems Music Corp.)
28/29, St. James Square,
London, S.W. 1.
Tel: Grosvenor 8312

SOUTHERN MUSIC PUBLISHING CO. LTD.

(Bijou Music Pub. Co. Ltd.)
(Bluebell Music Pub. Co. Ltd.)
(Cedarwood Music Ltd.)
(Dunmo Music Pub. Co. Ltd.)
(Iver Recording Co. Ltd.)
(Jamie Music Pub. Co. Ltd.)
(Latin-Amerixan Music Pub. Co. Ltd.)
(Liber-Southern Ltd.)
(Meridian Music Pub. Co. Ltd.)
(Meteor Music Pub. Co. Ltd.)
(Monique Music Ltd.)
(Most Music Pub. Co. Ltd.)
(Mirror Music Pub. Co. Ltd.)
(Southern Library of Recorded Music Ltd.)
(South Eastern Music Pub. Co. Ltd.)
(White Lodge Music Pub. Co. Ltd.)

8, Denmark Street,
London, W. C. 2.
Tel: Temple Bar 4524

SPARTA MUSIC LTD.

(Nobel-Arts Film Music Ltd.)
(Ember-Sparta Mood Music)
(Hal Shaper)
(Hal Shaper Ltd.)
(Halmusic Ltd.)
(The Moody Blues)
(Soul Music)
(Surefire Music)

36, Wardour Street,
London, W. 1.
Tel: Gerrard 2468

GOLD DISK WINNERS FROM BRITAIN

ENGLAND'S PRE 1961 GOLDEN DISK AWARDS

Diana
Let's Have A Party
Pette Fleur
Mary's Boy Child
O Mein Papa
Limelight
What Do You Want To Make
Those Eyes At Me Fo
Rock Around The Clock
We Will Make Love
Harry Lime Theme
He's Got The Whole World In His Hands
Auf Wiedersehen
Charmaine
It's Now Or Never
Living Doll
Freight Train
Cara Mia

Paul Anka
Winifred Atwell
Chris Barber
Harry Belafonte
Eddie Calvert
Frank Chacksfield
Emile Ford

Columbia
Philips
Pye
RCA
Columbia
Decca
Pye

Bill Haley
Russ Hamilton
Anton Karas
Laurie London
Vera Lynn
Mantovani
Elvis Presley
Cliff Richard
Nancy Whiskey
David Whitfield

Brunswick
Oriole
Decca
Parlophone
Decca
Decca
RCA
Columbia
Oriole
Decca

ENGLAND'S GOLD DISK AWARDS 1961-1962

Apache
Are You Sure
Does Your Chewing Gum Lose Its Flavour
Midnight In Moscow
Stranger On The Shore
The Young Ones

The Shadows
The Allisons
Lonnie Donegan
Kenny Ball
Acker Bilk
Cliff Richard

Columbia
Fontana
Pye
Pye
Columbia
Columbia

ENGLAND'S GOLD DISK AWARDS 1962-1963

I Remember You
Telstar
Lovesick Blues

Frank Ifield
The Tornados
Frank Ifield

Columbia
Decca
Columbia

ENGLAND'S GOLD DISK AWARDS 1963-1964

A World Without Love
Bachelor Boy/The Next Time
Bits & Pieces
Can't Buy Me Love
Diane
Glad All Over
I Want To Hold Your Hand
Lucky Lips
Lovesick Blues
Little Children
Needles And Pins
She Loves You

Peter & Gordon
Cliff Richard
Dave Clark Five
The Beatles
The Bachelors
Dave Clark Five
The Beatles
Cliff Richard
Frank Ifield
Billy J. Kramer
The Searchers
The Beatles

Columbia
Columbia
Columbia
Parlophone
Decca
Columbia
Parlophone
Columbia
Columbia
Parlophone
Pye
Parlophone

L.P. awarded to The Beatles for million sales of their Parlophone L.P. "With The Beatles."

ENGLAND'S GOLD DISK AWARDS 1964-1965

Do Wah Diddy Diddy
Downtown
Have I The Right
I'll Never Find Another You
By Boy Lollipop
You Really Got Me

Manfred Mann
Petula Clark
The Honeycombs
The Seekers
Millie
The Kinks

H.M.V.
Pye
Pye
Columbia
Fontana
Pye

Attention!

New Address

GOOD MUSIC L.T.D.

(in Co-operation with ESSEX Music LTD —
Dav. Platz General Manager)

4 DENMARK STREET
LONDON WC 2
Tel. Coren Garden 1024

ROY PITT — A & R Monogor

JOE RONCORONI

and

KEN JONES

of

MARQUIS MUSIC LTD.
VERULAM MUSIC LTD.

on behalf of their artistes

EDWIN ASTLEY

THE DOLLIES

JONATHAN KING

JAMIE POWER

THE ZOMBIES

Recorded Exclusively by

MARQUIS
ENTERPRISES LTD.

Send Greetings to their
publishing friends
throughout the world.

37 Soho Square
London, W.1.
England

Telephone:
GERRARD 9405/6

Cable:
MARQUIMUS

SPARTA
MUSIC LTD.

Europe's youngest
established Publishing House

current INTERNATIONAL hits

GREAT BRITAIN

"BEFORE AND AFTER"
Chad and Jeremy

"YOU TURN ME ON"
Ian Whitcomb

"FROM THE BOTTOM OF
MY HEART"
The Moody Blues

FRANCE

"IL FAIT CHOU" (Hush)
Sheila

"NO TEARS FOR JOHNNY"
Mavie Lafouvet

"MY BABY'S GONE"
The Moody Blues

and

Winners of the British Song Festival
with Kenny Lynch

"I'LL STAY BY YOU"

36 WARDOUR STREET
LONDON W1, GER: 2468/9



Deutsche
Grammophon
Gesellschaft

RECORDS
OF
SUPREME
QUALITY

Incorporating

'E' COLLECTION • ARCHIVE
HELIODOR • POLYDOR

Deutsche Grammophon (Gt. Britain) Ltd.
12/13, Rathbone Place, Oxford Street,
London, W. 1.

**THE
SOUND
THAT
SELLS
AROUND
THE
WORLD**

**ABC-
PARAMOUNT**



MANY OF THE
**WORLD'S
 GREATEST
 ARTISTS
 ARE
 RECORDED
 ON**



CAROL
 CHANNING



RAY CHARLES
 (SINGERS)



LEW
 DAVIES



DE CORMIER
 (SINGERS)



ALFRED
 DRAKE



LEE
 EVANS



BOB
 HAGGART



DICK
 HYMAN



ENOCH
 LIGHT



CHARLES
 MAGNANTE



TONY
 MOTTOLA



TESSIE
 O'SHEA



ROBERTA
 PETERS



"DOC"
 SEVERINSEN



WILLIAM
 STEINBERG



DICK
 VAN DYKE

ARTISTS SHOWN ABOVE ARE LISTED IN ALPHABETICAL ORDER

Command®



**WORLD
 LEADER
 IN
 RECORDED
 SOUND**

ABC-PARAMOUNT RECORDS, INC. A Subsidiary of American Broadcasting Companies, Inc.

ABC-PARAMOUNT RECORDS/COMMAND RECORDS/IMPULSE! RECORDS/WESTMINSTER RECORDS
 abc RECORDS

1501 BROADWAY, NEW YORK 36, N. Y.

13

IS A LUCKY NUMBER IN GERMANY

JUST CHECK THIS LIST OF

★ ★ 13 (COUNT EM') 13 ★ ★

SWINGING PUBLISHING FIRMS

THAT WE REPRESENT!

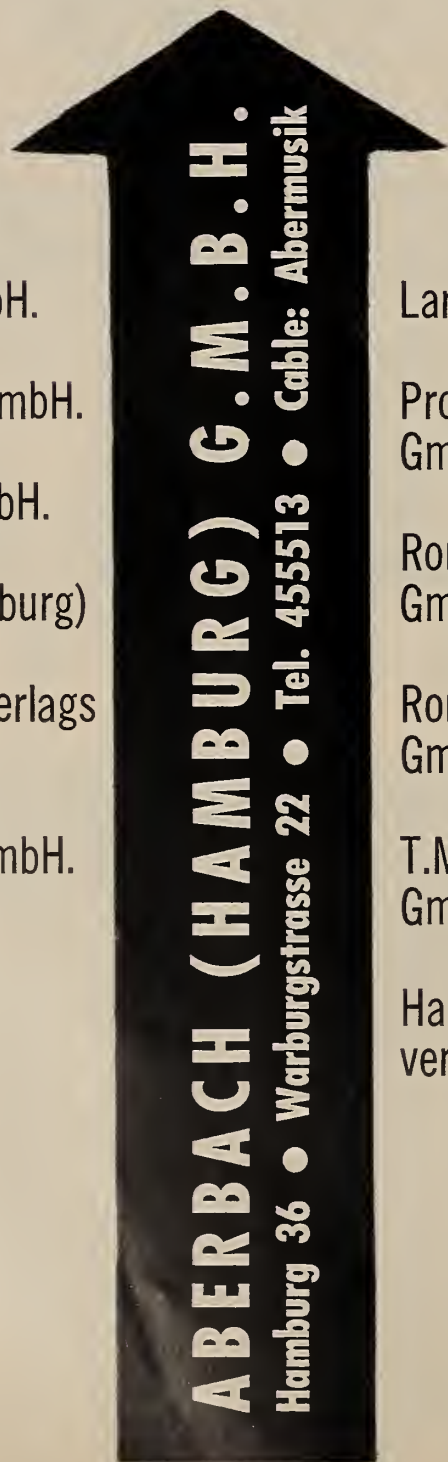

ABERBACH (HAMBURG) G.M.B.H.

Hamburg 36 • Warburgstrasse 22 • Tel. 455513 • Cable: Abermusik

Barton GmbH.

Bella-Ton GmbH.

Benday GmbH.

Colby (Hamburg)

Harmonie Verlags GmbH.

Kalman GmbH.

Lark GmbH.

Progressive GmbH.

Rondo Verlags GmbH.

Ronny (Hamburg) GmbH.

T.M. Musikverlag GmbH.

Hanseatic Musikverlag GmbH.

Germany—The Past Twelve Months

The last year in Germany has seen several important changes which could revolutionize the business here. LP sales, especially stereo, have zoomed up to take an even more important slice of the dollar sales market here and the singles business evened out somewhat with a small drop of 3.7% as compared to over 20% loss last year. The last year has seen a virtual domination of the market by independent producers in the singles field with several indie producers starting their own label for the first time here. Low priced LP's have done terrific business and will continue to be an important factor in the market. The English beat groups continued to rack up terrific sales here led by The Beatles, The Kinks and The Rolling Stones. German music had a terrific year export-wise as Bert Kaempfert continued his winning ways with several smash hits; Helmut Zacharias landed a top hit in the English hit parade; Udo Jurgens became a sales sensation all over Europe and his tune "Walk Away" also did chart business through Matt Monro in the U.S.; and Horst Jankowski turned out a smash LP and single "A Walk Through The Black Forest" which made the top 10 in the Cash Box Top 100.

Only 22 LP's made the top 10 charts as old favorites such as "My Fair Lady" and "West Side Story" continued to dominate sales wise. 12 of the 22 chart LP's were German productions. Only one LP named and produced after a singles hit made the top 10 and that was an English beat production done in Germany by Casey Jones & The Governors. All of the other LP's were standard productions with the exception of 3 LP's of current hits with various artists and 1 LP of carnival songs. A strange wedding took place through popular magazines as Teldec and Electrola banded together for some LP productions through Hoer Zu and Philips and Polydor then did the same with Stern. CBS also leased some masters to Polydor for an LP production. Singles-wise, 22 publishers divided the 90 hits which made the top ten listings. Of this number, exactly 2/3, or 60 numbers were of German origin. 9 English records, 3 of which had equally important German covers, 1 Spanish speaking record, 1 French speaking record and 2 instrumentals got into the top 10 and all the rest of the records were German language vocal singles. Here's a month to month review of the happenings in Germany as reported by Cash Box.

Executive changes at Philips saw public relations head Wolfgang Kretschmar move to the head of the production/program department for the firm in a great promotion for the fine young executive. The well known journalist in the trade Hannes Flesner took over the public relations department handling press, artist promotion, and radio-TV promotion. Trade paper "Automaten Markt" took a poke at the record industry for lack of consumer advertising and the drop in record popularity as a Xmas gift and in sales.

Trade Paper "Musikmarkt" listed the top artists of the year and first place honors went to Bernd Spier-CBS as top male artist, Siw Malmkvist-Metronome as top female artist, The Beatles for vocal groups and Jacques Loussier of Teldec as instrumental favorite. The top LP of "64" was "My Fair Lady" in the original German cast on Philips, and the top single according to the magazine was "Liebeskummer Lohnt Sich Nicht" ("It Doesn't Pay To Be Lovesick"), the winner of the German song festival for "64" and recorded by Siw Malmkvist on Metronome. The artists for the German Song Festival "65" from the record firms were announced.

JANUARY

The new year started with the firms all reporting on their success in "64". Ariola reported their best year in the history of the firm sales-wise. CBS wrapped up their second year of business with a 280% sales

increase over the previous year. Deutsche Grammophon reported that classical sales were up 15% putting the firm in first place on the classical sector here. Deutsche Vogue also had their best year since they have been in business. Electrola had their best year since the war with singles just about holding their own and LP sales up 69% over the previous year. Austroton had their first hit group in the charts constantly as Jimmy and The Rackets lead up sales for their Elite Special label. Metronome celebrated their best year in their 10 year history with strong singles sales and increasing LP action. Philips had a great LP year with "My Fair Lady" selling over 1/2 million LP's to lead sales. Teldec also increased sales LP wise and had a great singles year.

"Musik Parade" a teen oriented magazine picked their readers' favorites. Musician of the year was Max Gregor of Polydor with Al Hirt of RCA picking up international honors. Male singer of the year was Draf Deutscher of Decca on a local basis and foreign honors went to Cliff Richard of Columbia. Distaff honors went to Manuela of Telefunken locally and Connie Francis of MGM on the foreign side. The favorite local group was the Rattles of Philips-Star Club and Odeon's The Beatles picked up foreign honors. Instrumental groups were led by Hazy Osterwald of Electrola locally and The Shadows for foreign appeal. Dance band winners were Max Greger of Polydor locally and Ray Conniff on the international scene. Favorite local D.J. was Camillo Felgin of Radio Luxemburg and first place on the international D.J. scene was Mal Sondock of West and South German Radio. Top hits of the year were "Shake Hands" by Draf Deutscher for Decca and "A Hard Day's Night" for The Beatles as top foreign hit.

The trade paper "Muenzautomat" had the German version of "You Can Never Stop Me Loving You" by CBS's Bernd Spier as the top juke box hit of "64". Polydor's Freddy Quinn did a 30 city tour of Germany with SRO crowds in every City. An LP was done during the tour of a live performance and the LP also entered the top 10 charts sales wise. The Letkiss began to move as a dance favorite here. Hans Gerig published the top selling Letkiss recorded by Roberto Delgado of Polydor. Englishman John Newton took over the radio promotion slot at Polydor from Heinrich Prinz who joined the A&R team in Frankfurt. Indie production teams began to sprout up like grass and as the year opened, 3 of the top 10 were indie productions. All firms with the exception of Electrola were hot on the heels of new masters from indie producers. Electrola opened their doors as the year ended. Beat band material became more and more hot item business as the year progressed.

Trade paper "Automaten Markt" listed their poll winners to round out the trade opinions for the year. Male artist honors went to Bernd Spier of CBS with Siw Malmkvist of Metronome taking distaff honors. Top vocal team honors went to Rex Gildo and Gitte of Electrola and instrumental honors went to Al Hirt. Top juke box hit was "You Can Never Stop Me Loving You" by Bernd Spier of CBS in German. Heinz Voigt took over the directorship of pop music for D.G.G. Polydor. Former director of pop production Kurt Richter took over directorship of Teldec.

FEBRUARY

The trade journeyed back from San Remo where Bobby Solo hit the top and the song went on to become a top hit in Germany. A&R man Werner Scharfenberger journeyed to Detroit to record The Supremes in German which also became a top ten hit. Bert Kaempfert had a chart item in the U.S. with "Red Roses for a Blue Lady." Carnival time came to Germany and amid the celebrations a great number of special carnival

(Continued on page 37)



THE SIXTY-SEVENTH YEAR

1964



1965

First Releases

Complete Recording of "Daphne" by Richard Strauss with Hilde Güden singing the title-rôle · Conductor: Karl Böhm

FOR THE FIRST TIME IN STEREO:

Janacek: "Diary Of One Who Vanished" · Ernst Haefliger, tenor · Rafael Kubelik, piano

Alban Berg: "Wozzeck" with Dietrich Fischer-Dieskau singing the title-rôle and Evelyn Lear as Marie

Conductor: Karl Böhm

Richard Strauss: "Frau ohne Schatten" · Conductor: Joseph Keilberth

Important New Releases

Brahms Series: Herbert von Karajan · Conclusion of the symphonic Schumann series under Rafael Kubelik
Continuation of the Bruckner series under Eugen Jochum · Extensive Sibelius production on the occasion of the
composer's 100th birthday · Conductor: Herbert von Karajan

Complete Beethoven Sonatas: Wilhelm Kempff · Chopin production: Tamàs Vásàry

Mozart: "Magic Flute" under Karl Böhm · Verdi: "Rigoletto", La Scala di Milano under Rafael Kubelik
with Dietrich Fischer-Dieskau singing the title-rôle · Ravel: "L'heure espagnole" under Lorin Maazel

Extensive recordings of opera in French are made in coordination with our affiliate company in Paris.

Janacek: "Slavonic Mass" under Rafael Kubelik · Stravinsky: "The Rite Of Spring" under Herbert von Karajan

Berlioz: "Symphony fantastique" under Herbert von Karajan

Telemann: "Banquet Music, Productions I, II and III" · Bach: "St. John Passion"

New exclusive contracts were signed with the following artists:

Christian Ferras, violin · Fritz Wunderlich, tenor

The head of Deutsche Grammophon's Archive Production, Dr. Hans Hickmann,
was awarded the title of "Professor"

Awards

The following works have been awarded the Grand Prix du Disque:

AS "WORLD'S BEST RECORDING":

the box edition "Johannes Brahms interpreted by Herbert von Karajan" · Four Symphonies
Violin Concerto · Haydn Variations and A German Requiem

Gundula Janowitz · Eberhard Waechter · Wiener Singverein · Berlin Philharmonic Orchestra

Complete Recording of Verdi's "Rigoletto" (La Scala di Milano) · Dietrich Fischer-Dieskau singing the title-rôle

Renata Scotto · Carlo Bergonzi · Fiorenza Cossotto · Ivo Vinco

Chorus and Orchestra of La Scala di Milano · Conductor: Rafael Kubelik





Awards

AS "BEST OPERA ENSEMBLE OF THE YEAR":

The first complete recording of Richard Strauss' "Daphne" with Hilde Güden singing the title-rôle
Conductor: Karl Böhm

AS "BEST SINGER OF THE YEAR":

Dietrich Fischer-Dieskau for his interpretation of the title-rôle in Verdi's "Rigoletto"

AS "BEST LIEDER-SINGER OF THE YEAR":

Grace Bumbry for her interpretation of "Gipsy-Songs" by Brahms and Schubert Lieder

THE FOLLOWING WORKS HAVE BEEN AWARDED THE GRAND PRIX DU DISQUE:

Schumann: Symphony No. 3 · Berlin Philharmonic Orchestra · Conductor: Rafael Kubelik

Mozart: String Quartets, K. 387 and K. 464 · Amadeus Quartet

Mahler: "Kindertotenlieder" · Dietrich Fischer-Dieskau · Berlin Philharmonic Orchestra

Conductor: Karl Böhm · Brahms: "A German Requiem" · Gundula Janowitz · Eberhard Waechter

Wiener Singverein · Berlin Philharmonic Orchestra · Conductor: Herbert von Karajan

Janacek: "Diary Of One Who Vanished" · Ernst Haefliger, tenor · Rafael Kubelik at the piano

Brahms: "Piano Works" interpreted by Wilhelm Kempff

A New Release of Deutsche Grammophon's Archive Production with the Paris Chamber Orchestra

Works by M.-R. Delalande and J.-J. Mouret · Adolf Scherbaum, trumpet

Conductor: Paul Kuentz

The new release of our affiliate company, Paris, under the "Literary Archive" label: Jean-Paul Sartre: Huis Clos

Furthermore Deutsche Grammophon was awarded the following prizes: The Edison-Prize in the Netherlands.

The Prize of The German Schallplattenkritik (record critics) in Berlin.

Artists Performing Around the World

JAPAN:

Rafael Kubelik with the Bavarian Radio Symphony Orchestra

Dietrich Fischer-Dieskau's first appearance as a concert and opera singer

Wilhelm Kempff · Irmgard Seefried · Wolfgang Schneiderhan

USA:

Karl Böhm: extensive conducting activities at the Metropolitan Opera, New York,

including the first performance of Alban Berg's "Wozzeck" in English.

Herbert von Karajan and the Berlin Philharmonic Orchestra: Beethoven concert series in New York,

followed by a tour of the USA. Herbert von Karajan · Eugen Jochum

Karl Richter: sensational success with the Munich Bach Choir and Orchestra in New York and Washington

(first visit to the USA). Wide discussions among the public about his Bach interpretation.

Géza Anda, Amadeus Quartet: longest concert tour since its foundation. Educational work at the Aspen Music

Festival. Campus Concerts at universities and colleges, plus touring the whole of the USA.

Grace Bumbry · Fischer-Dieskau · Pierre Fournier · Ernst Haefliger · Gundula Janowitz

Wilhelm Kempff (first appearance in the USA) · Evelyn Lear · Irmgard Seefried

Adolf Scherbaum, trumpet (four months in the USA) · Jess Thomas · Tamás Vásáry



Artists Performing Around the World

EUROPE:

Herbert von Karajan and the Berlin Philharmonic Orchestra open the Sibelius Festival in Helsinki and the International Music Festival in Bergen, Norway, followed by tours in Sweden and Denmark
Music Festivals in Lucerne (Switzerland) and Greece
A large number of the artists performing at the festivals in Salzburg, Lucerne, Vienna, Berlin and Edinburgh are under contract to Deutsche Grammophon.



Distribution and Sales Activities

On October 1st, 1964, Deutsche Grammophon published the subscription notice for the Johannes Brahms box-edition conducted by Herbert von Karajan. This subscription campaign was started in many European countries: Belgium, Denmark, Germany, Finland, France, Greece, Great Britain, Holland, Italy, Luxemburg, Austria, Sweden, Switzerland

The box-edition sales of Gustav Gründgens' production of Goethe's "Faust" reached the 50,000 mark. Nippon Grammophon, Tokyo, doubled their capital and started representing MGM and VERVE

During the Royal State Visit to Germany in May 1965, the Lord Mayor of Bonn presented Her Majesty Queen Elizabeth II with Deutsche Grammophon's box-edition of Beethoven's Nine Symphonies, performed by the Berlin Philharmonic Orchestra under the conductorship of Herbert von Karajan.

60 hours after the Royal Yacht "Britannia" left Hamburg, Deutsche Grammophon released the LP "Queen Elizabeth II in Germany". This record spotlights all important stations of Her Majesty's German visit. 250 selected dealers from several European countries were awarded a special plaque for their particular efforts and interest in the Archive series. These dealers now stock the complete range of Archive records. "V 65" is the title of the big new Europe-wide spring release campaign. More than 2,000 dealers were furnished with special self-service sales aids containing important standard discs and featuring the 54 new releases.



Latest News from Polydor

Bert Kaempfert's rendition of "Red Roses For A Blue Lady", recorded in Hamburg, became a hit in the USA and reached the European charts. Freddy recorded his newest hit single, "Adios Mexico", "5,000 Meilen von zu Haus", in USA · Claus Ogermann conducted the orchestra.

"Schenk mir ein Bild von Dir" is the title of Peter Alexander's current hit.

Polydor has successfully launched a new series of folklore LP's with the following artists:

The Kieseletter Family · Karl Wolfram · Hai and Topsy · Peter Rohland and Schobert Schulz.
Günther Kallmann and his Choir are busy preparing for their forthcoming tour of South Africa.

"Show of the Year" is the distinctive title given to Freddy's 1965 sensational European tour.

Wencke Myhre won the second prize at the German Festival of Popular Song in Baden-Baden with her song "Sprich nicht drüber".

Alfred Hause, "King of the Contental Tango", returned from a highly successful four-week tour of Japan. At his last concert he was presented to the Emperor and Empress and other members of the Japanese Imperial Family who were in the audience. Nippon Grammophon has sold more than a quarter of a million Alfred Hause records during the past two years.



OWN LABELS:



**ARCHIVE
PRODUCTION**



Brunswick



REPRESENTED LABELS:

MGM



MANAGEMENT AND ADMINISTRATION
2 Hamburg 13 · Harvesthuder Weg 1—4

RECORDING STUDIOS
Berlin, Hamburg, Hannover, Cologne, Munich

PRESSING PLANTS
Werk I: 3 Hannover, Podbielskistrasse 164
Werk II: 3012 Langenhagen (Hannover), Klusriede 26

AFFILIATED AND OTHER COMPANIES:

POLYDOR S.A. PARIS
2, Rue Cavallotti
Paris (18^e)/France

KARUSELL GRAMMOFON AB
Postfack
Solna 1 b/Stockholm/Sweden

DEUTSCHE GRAMMOPHON
(GREAT BRITAIN) LTD.
12/13 Rathbone Place
Oxford Street
London W 1/England

DISCOS UNIVERSALES S.A.
Calle Rio Tiber 58
Mexico 5 / D.F. / Mexico

FINTONE OY
Munkkisaarekatu 2
Box 10033
Helsinki/Finland

POLYPHON
SCHALLPLATTEN GESELLSCHAFT MBH
Mariahilfer Strasse 127
Wien VI/Austria

NIPPON GRAMMOPHON CO. LTD.
Kimura Building
7, 1-chome, Shinbashi, Shiba Minato-ku
Tokyo/Japan

New Establishment of Companies

A/S NOR-DISC
Oslo/Norway

SA POLYDOR NV
Brussels/Belgium

POLYDOR NEDERLAND NV
The Hague/Holland

SA POLYDOR LUXEMBURG
Luxemburg

Germany—The Past Twelve Months

(Continued from page 30)

records were sold. Deutsche Vogue and Hans Gerig Music began an all out push on the English and German versions of "Downtown" by Petula Clark which became a chart topper here. Wanda Jackson did her first German waxing for Electrola which also made the top 10. Freddy Quinn started his Germany tour of 30 cities which not only did tremendous business but also produced a top 10 live LP. German record firms became very beat oriented and began to record plenty of English artists living here in English for this market and several groups including Casey Jones and The Governors for Golden 12/Metronome, Jimmy and the Rackets for Elite Special and the Liverbirds for Star Club/Philips came up with smash singles and LP's for this market.

The Swinging Blue Jeans made their first tour of Germany. Jacques Loussier who has top 10 LP's with his "Play Bach" series made his first tour as well. Stereo sales picked up to an extent that the major record firms began to issue their LP's in compatible form to be played in stereo or on mono players. German Vogue changed their management set up as Jean Jacques Finsterwald continued as Managing Director, the new assistant director is Roger Lilla, distribution boss remains Klaus Paulus, sales manager Heinz Jurgens and International Manager and press chief Larry Yaskiel.

MARCH

Dorthe joined the Philips fold from Metronome and her first waxing for the firm was a hit. Teldec signed the "Top 10" beat club to a contract for recordings directly from the club. Heinz Lucas left Philips and York Von Prittwitz took his music promotion and radio promotion department over. York left CBS to take on the new Philips position. Germany's exports sales and music wise began to rise with Horst Jankowski and Bert Kaempfert along with Udo Jurgens leading the way to top international hits. Bravo, Germany's biggest teen fan magazine voted Cliff Richard for the second time in a row as the most popular male artist in Germany, with The Beatles finishing second. Germany's Freddy Quinn took 3rd place honors. On the distaff side of the picture, first place went to Gitte from Denmark with Germany's Manuela taking second place and Connie Francis moving to 3rd. A&R man Lothar Olias of Polydor took over the production of Lolita. A new booking agency, Interart, from Dusseldorf opened with a successful concert tour of Casey Jones and The Governors The Lords from Germany and the Beat-Chics. The tour was a great success.

France Gall who won the song for Europe contest with her Luxemburg entry became a household name in Germany and the winning tune became a top hit here. Teldec started the push on their new "royal sound" stereo. Wilhelm Klofat returned to Ariola-Eurodisc as head of promotion and press replacing Michael Andries who joined Interart promotions.

"Annie Get Your Gun" was televised here in the original German version to give a boost to Philips records sales. Ralph Maria Siegel had a top smash with "Pretty Woman" by Roy Orbison and "The Wedding" by Julie Rogers.

Sports stars were in the news record wise as 3 top sports figures had top discings here. Skater Hans Jurgen Baumler had a top 10 hit for CBS, Munich soccer goalie Peter Radenkovic had a smash for Teldec and sprinter Martin Lauer had another hit for Polydor.

APRIL

"Downtown" by Petula Clark topped the hit parade here. Teldec awarded a third golden record to Ernst Mosch and the original Egerlander Musikanten for sales topping 4 million in Germany. Film star Pierre Brice joined the Teldec fold as an artist. D.G.G.-Polydor started a

special series of LP's culled from their extensive catalogue for a full promotion all over Europe. Bert Kaempfert celebrated his 50th birthday with a big shindig in Hamburg. More and more time has been devoted to pop records in TV which have had a good reflection in sales here. The German Radio-TV fair was set for Stuttgart for the first time. The fair will be held in August. Barbara Kist of Schaeffers Music left the firm to take over the AME publishing firm of Ed Kassner. Gaby Richt left Montana Music to take over for Barclay Records here. English A&R man Paul Murphy left Polydor for Alpha Production post under Caterina Valente's husband Eric Von Aro. The Aaron Schroeder publishing interests shifted from Peter Meisel to Edition Accord. Electrola's The Peanuts from Japan were booked for the German Song Festival.

MAY

Cabaret star Helen Vita passed the 100,000 mark with LP's sold for Vogue. UFA Music announced that they will start their own label in September distributed by Ariola-Eurodisc. Both the publishing firm and record company belong to Bertelsmann. Oscar Peterson and his trio toured Germany. Peter Meisel's Hansa label landed two hot masters and both racked up terrific sales. One was "Il Silenzio" by Nini Rosso which went on to the number 1 slot in Germany and sales of over 1/4 million and the other was "Cadillac" by The Renegades, an English group living in Finland. Ann Busse left the Busse Music complex to take over the new Telstar publishing group owned by Echolette. Record firms began heavy production of regional records for vacation business. CBS issued a group of standard stereo singles. Trouble began popping up regarding the German Song Festival and the choosing of material for the festival by the jury. Electrola won an important court case from indie distributors since the firm set up their own distribution net and took the label away from the indies.

JUNE

The German Song Festival ended in a win for "Mit 17 Hat Man Noch Traeume" sung for RCA by Peggy March. Second place went to Polydor's Wencke Myhre and third place to Siw Malmkvist of Metronome. All three records and several other festival tunes immediately picked up saleswise. Other top items included the new German Cliff Richard single of "I Could Easily Fall In Love With You" and "Il Silenzio" by Nini Rosso. Freddy Quinn, Germany's top record artist did his first English single for Kapp. Peter Walter of the Big Apple Night club brought in The Animals for their first concert here. The Pretty Things also made their first appearance at the club. Teldec picked up the Reprise label from Ariola for Germany. Teldec issued a new "Beat for Beaters" series of hard rock sounds.

JULY

GEMA won a court battle and now receives 5% of the sales price of tape recorders for the authors. Copyright laws were amended in Germany to give composers a 70 instead of a 50 year protection. Vogue started a new low priced series of beat LP's.

Heinz Gietz gave up his position as head of production at Electrola to take on a non-exclusive agreement with the firm as chief producer. Heinz's partner, Gunter Ilgner leaves Electrola as administrative director to work exclusively for the partnership productions with all labels. Electrola is for the first time open to independent production through this move.

That is the year that was. Trends toward long play records continued to grow. The singles drop slowed down to a trickle which shows a steady balancing of sales. The indie producer is "in" with almost all of the major A&R men now working on a non-exclusive basis for several labels.



IF YOU HAVE A
HIT FOR ME —
LET ME BUILD IT
UP IN GERMANY
FOR YOU — I'VE
DONE IT MANY A
TIME!

Yours

RALPH MARIA SIEGEL
MUSIC PUBLISHER
MUNICH 23

**DIE BESTEN DEUTSCHPRACHIGEN SÄNGER
DES JAHRES**



**CATERINA
VALENTE**



**PETER
ALEXANDER**

gewählt von den Deutschen Schallplatten—Jockeys und
Fachjournalisten nach einer "Musikmarkt"—Umfrage.

**produced by
Kurt Feltz
Musikproduktion**

KÖLN, Drususgasse 7-11 / Phone: 215723

Telex: 8881673

We are also responsible for:

**SACHA DISTEL
MARTIN LAUER
RENE CAROL
WILLY SCHNEIDER
SVEN JENSSSEN
JERRY TOGER**

GERMANY—Music Publishers

ATLAS MUSIKVERLAG
Frau Hilla Steidtner
Percha/Starnberg
Tel: 08151-3232

ABERBACH MUSIKVERLAGE
Herr Rudolph Slezak
Hamburg 36
Warburg Str. 22
Tel: 455513

EDITION ACCORD
Herr Otto Dehmeler
Cologne
Hohenstaufern
Ring 63
Tel: 238067

PAUL C. R. ARENDS MUSIKVERLAGE
Herr Michael Arends
Rimsting (Bavaria)
(Edition Trumpf-Burlington Musik)
Tel: 08051-634

RALF ARNIE MUSIKVERLAGE
(Star Musikproduktion)
Herr Ralf Arnie
Hamburg 20
Wrangel Str. 5
Tel: 464041

ATRIUM MUSIKVERLAG
Herr Felix Stahl
Hamburg 13
Rothenbaum Chaussee 191

BIRNBACH MUSIKVERLAG
Herr Richard Birnbach
Aubinger Str. 9
Lochum
Tel: Munich 875450

BOSWORTH MUSIKVERLAG
Herr Hartmann
Hohe Str. 133
Cologne
Tel: 211479

ROLF BUDE MUSIKVERLAGE
Herr Rolf Bude
Berlin-W.
Kurfurstendamm 103
Tel: 8871045

KARL HEINZ BUSSE MUSIKVERLAGE
Herr Karl Heinz Busse
Sonnen Str. 20
Munich
Tel: 552621

CHAPPELL & CO
August Seith Music
Herr August Seith
Sendlinger Tor Str. 10
Munich
Tel: 596828

CAPRICCIO MUSIKVERLAG
Herr Peter Lach
Hamburg 1
Mönckeberg Str. 5
Tel: 334096

EDITION ESPLANADE
Frau Bornemann
Hamburg 39
Rathenau Str. 25
Tel: 518211

HANS GERIG MUSIKVERLAGE
Herr Hans Gerig
Cologne Drusus Gasse 7/11
Tel: 234833

GABRIEL MUSIKVERLAG
Hamburg-Grossflottbek
Mullenhoffweg 25
Tel: 894152

IDEE MUSIC VERLAG
Herrn Fritz Schack
Berlin 30
Polistrasse 58
13 46 58

EDITION INSELTON
Munich 2
Karlsplatz 19/20

MICHAEL JARY MUSIKVERLAG
Hamburg 13
Harvestehuderweg 5

OTTO KUHL MUSIKVERLAGE
Mr. Jack Joseph
Cologne
Am Hof 34/36
Tel: 212276
(Weston Music)

WILL MEISEL MUSIKVERLAGE
Herr Rudolph Schroeder
Berlin-W.
Wittelsbacher Str. 18
(Monopol, Meisel)
Tel: 902345

PETER MEISEL MUSIKVERLAGE
Herr Peter Meisel
Berlin-W.
Wittelsbacher Str. 18
Tel: 914057

MELODIE DER WELT MUSIKVERLAGE
Herr Michael
Frankfurt/Main
Oederweg 26
(Francis, Day & Hunter-Progress)
Tel: 590777

EDITION MIKADO
Charly Niessen
Belgrad Str. 86
Tel: 342359
Munich

MINERVA MUSIC
Herr Rudolph Von Der Dovenmuhle
Cologne-Nippes
(Tequila Music)
Nord Str. 17A
Tel: 733961

MONTANA MUSIKVERLAGE
Herr Hans. R. Beierlein
Nussbaum Str. 16
Munich
Tel: 534000

EDITION MODERN
Herr Hans Wewerka
Munich
Franz Joseph Str. 2
Tel: 334408

EDITION MARBOT
Frau Bilkenroth
Hamburg 13
Born Str. 12
Tel: 446606

NERO MUSIKVERLAG
Herr Gerd Hammerling
Berlin-W.
Wittelsbacher Str. 18
Tel: 914057

PEER MUSIKVERLAGE
Herr Theodor O. Seeger
Klaerchen Str. 11
Hamburg
(Southern Music)
Tel: 488645

QUINT MUSIKVERLAG
Herr Dr. Stein
Munich 2
Nymphenburger Str. 38
Tel: 550685

EDITION ROYAL
Herr Hans Lang
Munich 23
Nikolai Platz 6
Tel: 361577

BERNARD MIKULSKI MUSIKVERLAG
Herr Bernhard Mikulski
Frankfurt/Main
Palmengarten Str. 4
Tel: 775544

PETER SCHAEFFERS MUSIKVERLAGE
Munich 2
Sendlinger Str. 23
Tel: 262091

RALPH MARIA SIEGEL MUSIKVERLAGE
Herr Ralph Maria Siegel
Munich
Am Biederstein 7
Tel: 347011/12

ALFRED SCHACHT MUSIKVERLAGE
Hamburg 13
Heinrich Barth Str. 13
Tel: 445323

PAUL SEIGEL MUSIKVERLAGE
Mr. Paul Siegel
Berlin-W.
Tauentzien 16
(Hi-Fi Music)
Tel: 247029

HANS SIKORSKI MUSIKVERLAGE
Herr Karl Breuer
Hamburg 13
Johns Allee 23
Tel: 450777

SOLAMI MUSIKVERLAG
Munich 9
Ravenna Str. 48
Tel: 497297

SONG EDITION
Herr Heino Gaze
Gustav Freytag Str. 9
Berlin-W.
Tel: 893971

ERICH STORZ MUSIKVERLAGE
Osterode/Reiheit
Haupt Str. 61

TELSTAR MUSIKVERLAG GMBH
Frau Ann Busse
Munich 23
Martius Strasse 6
34 55 49

TRANSATLANTIK MUSIKVERLAG
Herr Karl Karthal
Schleusenstr. 18
Frankfurt/Main
Tel: 333476

TUTTI MUSIKVERLAG
Frau Gamber
Frankfurt/Main
Eschersheimerland Str. 12
Tel: 592996

UFATON MUSIKVERLAGE
Herr Rudolf Foerster
Munich Sonnen Str. 19
(Weiner Boheme Verlag)
Tel: 557957

SERVING THE INTERNATIONAL MUSIC BUSINESS

**FASTEST RECORD DELIVERY THROUGHOUT THE WORLD BY AIR MAIL
COMPLETE LINE OF ALL AMERICAN LABELS**

ALL NEW RELEASES

AIRDISC U.S.A.

SINGLES • ALBUMS

Every quantity shipped. Prices
on request.

Box 545, Radio City Station
New York, N. Y. 10019

Payments by bank draft or In-
ternational Money Order or on
account.

TELDEC

REPRESENTING
THE WORLD'S MOST
IMPORTANT RECORD LABELS
AND INTERNATIONALLY
FAMOUS ARTISTS
IN GERMANY

The Rolling Stones (DECCA)

Caterina Valente (DECCA)

Vico Torriani (DECCA)

Will Glahe (DECCA)

Werner Müller (DECCA)

Mantovani (DECCA)

Ted Heath (DECCA)

Edmundo Ros (DECCA)

Los Machucambos (DECCA)

Drafi Deutscher (DECCA)

Hildegarde Neff (DECCA)

(Hildegard Knef)

The Bachelors (DECCA)

Pierre Brice (DECCA)

Manuela (TELEFUNKEN)

Ronny (TELEFUNKEN)

Egerländer Musikanten (TELEFUNKEN)

Oberkrainer Quintet (TELEFUNKEN)

Willy Schneider (TELEFUNKEN)

Harry Belafonte (RCA VICTOR)

Al Hirt (RCA VICTOR)

Elvis Presley (RCA VICTOR)

Peggy March (RCA VICTOR)

Paul Anka (RCA VICTOR)

Floyd Cramer (RCA VICTOR)

Duane Eddy (RCA VICTOR)

Chet Atkins (RCA VICTOR)

Bobby Bare (RCA VICTOR)

Jim Reeves (RCA VICTOR)

Rita Pavone (RCA VICTOR)

Neil Sedaka (RCA VICTOR)

Bob Moore (MONUMENT)

Roy Orbison (MONUMENT)

Peter, Paul & Mary (WARNER BROS.)

Everly Brothers (WARNER BROS.)

Allan Sherman (WARNER BROS.)

Count Basie (REPRISE)

Sammy Davis jr. (REPRISE)

Duke Ellington (REPRISE)

Dean Martin (REPRISE)

Nelson Riddle (REPRISE)

Frank Sinatra (REPRISE)

TELDEC

Schallplatten-
Gesellschaft mbH.
Hamburg/Germany



reprise:

KEEP SWINGING IN GERMANY WITH



MELODIE DER WELT

FRANCIS, DAY AND HUNTER

PROGRESS- MUSIK GMBH

PROGRESS
MUSIK GMBH

FRANKFURT/MAIN · GERMANY · OEDER WEG 26
CABLE: MELODIE-FRANKFURT

For publishing representation
in Germany
and other European countries:

Paul C.R. Arends Verlag
Edition Trumpf GmbH.
Burlington Musikverlag

managed by

Mrs. Gerda Arends

8211 Rimsting/Germany
P.O. Box 20

Telephone: (08051) 634
Cable: Arendsmusic, Rimsting



GERMANY'S BEST SELLERS (TOP TEN TUNES) OF THE LAST YEAR, JULY-JUNE (IN ORDER OF APPEARANCE ON CHARTS. NOT IN ORDER OF SALES)

Title	Artist	Distributor	Publisher
★Liebeskummer Lohnt Sich Nicht (It doesn't pay to be lovesick)	Siw Malmkvist	Metronome	Intro/P. Meisel
★Wunderschoenes Fremdes Maedchen (Wonderful stranger girl)	Hans Jurgen Baumler	CBS	Melodie Der Welt/ Michel
★Schoene Maedchen Muss Man Lieben (You've got to love beautiful girls)	Bernd Spier	CBS	Melodie Der Welt/ Michel
★Shake Hands	Drafi Deutscher	Decca	Intro/P. Meisel
★Napolii	Connie Francis	MGM	Francon/ Schneider
Schwimmen Lernt Man Im See (Just so Bobby can see)	Manuela	Telefunken	Rolf Budde Music
★Honeymoon In St. Tropez	Manuela	Telefunken	Rolf Budde Music
★Bye, Bye, Blondie	Manuela	Telefunken	Rolf Budde Music
★Schaffe, Schaffe, Haeusle Baue (Work, work, build a house)	Manuela	Telefunken	Rolf Budde Music
★Zwei Maedchen Aus Germany (Two girls from Germany)	Manuela	Telefunken	Rolf Budde Music
Sag "No" Zu Ihm (Don't talk to him)	Manuela	Telefunken	Rolf Budde Music
★Kein Gold Im Blue River (On top of old Smokey)	Ronny	Telefunken	Edition Marbot
★Jetzt Dreht Die Welt Sich Nur Um Dich (Now the world just revolves around you)	Manuela	Telefunken	Rolf Budde Music
★Wenn Der Silbermond (When the Silver Moon)	Peggy March	RCA Victor	Oktave Music/ Schacht
★Bravo Bambino	Rex Gildo	Electrola	Hans Gerig Music
★Junger Mann Mit Roten Rosen (Young man with red roses)	Dorthe	Metronome	Ralf Arnie Music
★Die Rose Von Mexico (The rose from Mexico)	Peter Hinnen	Ariola	Nero Music/ Hammerling/Meisel
My Boy Lollipop	Millie/Heidi Bachert	Fontana/ Polydor	Seith/Chappell
★Sein Bestes Pferd (His best horse)	Martin Lauer	Polydor	Hans Gerig Music
★Das Kommt Vom Rudern, Das Kommt Vom Segeln (That comes from rowing, that comes from sailing)	Peter Lauch and the Regenpfeifer	Golden 12/ Metronome	Transatlantic Music
★Wenn Du Mal Allein Bist (When you are alone)	Manfred Schnelldorfer	Decca	Karl Heinz Busse Music
★Ein Boy Ist Ein Boy (A boy is a boy)	Renate & Werner Leismann	Ariola	Ralf Arnie Music
★Oh My Sweetheart Rosemarie	Jurgen Herbst	CBS	Melodie Der Welt/ Michel
★Aus Jedem Land Ein Souvenir (From every country, a souvenir)	Vico Torriani	Decca	Ralf Arnie Music
★Hokus Pokus	Rex Gildo & Gitte	Electrola	Hans Gerig Music
★Okay, Ich Geh (Ok, I'll go)	Suzanne Doucet	Metronome	Mikado Music
★Keep Smiling	Drafi Deutscher	Decca	Nero Music/ Hammerling/P. Meisel
Memphis	Bernd Spier/ Pat Boone/ Claudio, Rik & Roger/ Johnny Rivers	CBS Vogue Polydor Liberty	Hans Gerig Music
★Seide & Samt (Silk & Velvet)	Peter Alexander	Polydor	Hans Gerig Music
Skinny Minnie	Tony Sheridan/ The Rackets	Polydor/Elite Special	Hans Gerig Music
★Adios Muchacho Goodbye	Bobby Solo	CBS	Melodie B Der Welt/Michel
Adalita	Trini Lopez	Reprise/Ariola	Publisher unknown
★Der Salontiroler	Billy Mo	Decca	Karl Heinz Busse Music
★Hello Boy	Peggy March	RCA Victor	Karl Heinz Musse Musci
★Ich Will Immer Auf Dich Warten (I will always wait for you)	Brenda Lee	Polydor	Hans Gerig Music
Pretty Woman	Roy Orbison	London	Acuff Rose/Maria Siegel Music
★Sweet Sweet Rosalie	Paul Anka	RCA Victor	Ralf Arnie Music
★Aber Mein Herz Ist Allein (But my heart is alone)	Hans Jurgen Baumler	CBS	Melodie Der Welt/ Michel
Du Du Gehst Vorbei (You, you pass me by)	Suzie	Deutsche Vogue	Montana Music/ Beierlein
★Vergangen, Vergessen, Vorueber (Gone, forgotten, all over)	Freddy Quinn	Polydor	Edition Esplanade/ Olias
★Schneemann (Snowman)	Manuela	Telefunken	Edition Intro/ P. Meisel
Das Ist Die Frage Aller Fragen (Spanish Harlem)	Cliff Richard	Columbia	Aberbach Music
Do Wah Diddy Diddy	Manfred Mann	Electrola	Marbot Music
★Kenn Ein Land (Know a land)	Ronny	Telefunken	Idee Music
Kleine Annabell (Little Annabell)	Ronny	Telefunken	Nero Music/ Hammerling/Meisel
★Cinderella Baby	Drafi Deutscher	Decca	Peer Music/Seeger Francon/Schneider
Tennessee Waltz	Alma Cogan	Columbia	Ralf Arnie Music
★Abends In Der Mondsscheinallee (Evenings in the Moonlight Alley)	Connie Francis	MGM	Edition Accord
★Kiddy Kiddy Kiss Me	Paul Anka & Rita Pavone	RCA Victor	Melodie Der Welt/ Michel
Rag Doll	The Five Tops/ Four Seasons	Philips	Melodie Der Welt/ Michel
Das War Mein Schoenstar Tanz (I only came to dance with you)	Bernd Spier	CBS	Transatlantic Music
★So Ein Seemann Macht Es Richtig (A sailor like that does things right)	Peter Lauch and the Regenpfeifer		
★Goodbye, Goodbye, Goodbye Diese Nacht Hat Viele Lichter (This night has many lights)	Peggy March	RCA Victor	Rolf Budde Music
★Kuesse Nie Nach Mitternacht (Never kiss after midnight)	Conny Froboess	Electrola	Progress Music/ Michel
★Taxi Nach Texas (Taxi to Texas)	Siw Malmkvist	Metronome	Edition Intro/ P. Meisel
★Elisabeth	Martin Lauer	Polydor	Hans Gerig Music
★Warten Ist So Schwer (It's so hard to wait)	Paul Anka	RCA Victor	Melodie Der Welt/ Michel
Downtown	Renate & Werner Leismann	Ariola	Ralf Arnie Music
Don't Ha Ha (Don't you just know it)	Petula Clark	Deutsche Vogue	Hans Gerig Music
★Die Frau Mit Dem Einsamen Herzen (The woman with the sad heart)	The Governors & Casey Jones	Golden 12/ Metronome	Robert Mellin/ Ralph Maria Siegel
Letkiss	Sacha Distel	Polydor	Hans Gerig Music
Melancholie	Roberto Delgado	Polydor	Hans Gerig Music
★Schenk Mir Ein Bild Von Dir (Give me a picture of you)	Peppino di Capri	Italia	Edition Accord
Ich Bin So Verliebt In Dich, Christina (Christina)	Peter Alexander	Polydor	Birnbach Music
★Lass Doch Die Alten Geschichten (Quit telling me the same old lies)	Bobby Solo	CBS	Rolf Budde Music
★Sorry Little Baby	Dorthe	Philips	Edition Intro/ P. Meisel
★Du Musst Bleiben, Angelino (You must stay, Angelino)	Hans Jurgen Baumler	CBS	Mikulski Music
Nashville, Tennessee	Connie Francis	MGM	Francon/ Schneider
Leider, Leider (Dear One)	Gitte	Electrola	Melodie Der Welt/ Michel
★Bin I Radi, Bin I Koenig (I'm Radi, I'm the King)	Gitte	Electrola	Chappell/August Seith
	Rex Gildo	Electrola	Chappell/August Seith
	Radi Radenkovic	Decca	Edition Mikado

(Continued on page 42)

Ahem....

Who had the most top ten hits
in Germany this year ?



GERIG

But why....

GERIG has had the most hits
five years in a row ?

It's easy....

GERIG

HAS THE BEST ORGANIZATION

GERIG

HAS THE BEST CATALOGUE

GERIG

HAS TREMENDOUS FOREIGN PARTNERS

MUSIKVERLAGE HANS GERIG · KÖLN

IF YOU WANT THE BEST EXPLOITATION OF YOUR SONGS IN GERMANY

contact

ROLF BUDDÉ MUSIKVERLAGE

Kurfurstendamm 103
Berlin 31, Germany

AUGUST SEITH

Music Publishers

Munich 15



GERMANY

FOR GERMANY'S TOP POP HITS!

EXCLUSIVE WHOLESALE SHEET MUSIC DISTRIBUTION
OR LEADING INTERNATIONAL PUBLISHERS!

ENDLINGERTOR PLATZ 10 • MUNICH 2, GERMANY

GERMANY'S BEST SELLERS (TOP TEN TUNES) OF THE LAST YEAR, JULY-JUNE (IN ORDER OF APPEARANCE ON CHARTS. NOT IN ORDER OF SALES)

(Continued from page 38)

★Tanz Die Ganze Nacht Mir Mir (Dance with me the whole night through)	Gerhard Wendland Philips	Melodie Der Welt/ Miebel
The Last Time	The Rolling Stones Decca	Hans Gerig Music
★Santo Domingo	Wanda Jackson Capitol	Hans Gerig Music
Heute Male Ich Dein Bild, Cindy Lou (The birds and the bees)	Draft Deutscher Decca	Intro/P. Meisel
★Hast Du Alles Vergessen? (Have you forgotten everything)	Draft Deutscher Decca	Intro/P. Meisel
Stop In The Name Of Love	The Supremes CBS	Aberbach Music
★Jenkka, Jenkka, Blindekub (Jenkka, Jenkka, Pin the tail on the donkey)	Cbris Howland Ariola	Ralf Arnie Music
★Kuesse Unterm Regenbogen (Kisses under the Rainbow)	Manuela Telefunken	Intro/P. Meisel
★Ich War Allein (I was alone)	Suzie Deutsche Vogue	Montana/Beierlein
★Thank You Darling	The Supremes CBS	Aberbach Music
Il Silenzio	Nini Rosso Hansa	Intro/P. Meisel
★Darling Goodnight	Ronny Telefunken	Edition Marbot
Es War Keine So Wunderbar Wie Du (I could easily fall in love with you)	Cliff Richard Columbia	Aberbach Music
★Messer, Gabel, Schere, Liebt (Knives, forks, scissors, lights)	Vicky Philips	Ralf Arnie Music
★Er Schoss Mir Eine Rose (He shot me a rose)	Peggy March RCA Victor	Melodie Der Welt/ Miebel
Es Koennte Schon Morgen Sein (The minute you're gone)	Cliff Richard Columbia	Hans Gerig Music
Ich Sb'e Dich Weinen (Se Piangi, Seridi)	Bobby Solo CBS	Rolf Budde Music
Poupee De Cire, Poupee De Son	France Gall Philips	Montana/Beierlein
★Mit 17 Hat Man Noch Traeume (You can still dream at 17)	Peggy March RCA Victor	Hans Gerig Music
★Original German Copyright		

Publishers of Songs in the German Top 10 in the Past Twelve Months

5 OR MORE SONGS

HANS GERIG MUSIKVERLAGE—17 SONGS
MELODIE DER WELT/PROGRESS/FRANCIS
DAY & HUNTER/MICHEL—13 SONGS
INTRO/NERO/PETER MEISEL/HAMMERLING
—12 SONGS
RALF ARNIE MUSIKVERLAGE—8 SONGS
ABERBACH MUSIKVERLAGE—6 SONGS

MORE THAN ONE SONG

ROLF BUDDÉ MUSIKVERLAGE—4 SONGS
KARL HEINZ BUSSE MUSIKVERLAGE—3
SONGS
EDITION MARBOT—3 SONGS
MONTANA MUSIKVERLAGE/BEIERLEIN—3
SONGS
SCHNEIDER/FRANCON MUSIKVERLAGE—3
SONGS

EDITION ACCORD—2 SONGS

MIKADO MUSIKVERLAGE/C. NIESSEN—2
SONGS
AUGUST SEITH/CHAPPELL MUSIKVERLAGE—
2 SONGS
RALPH MARIA SIEGEL MUSIKVERLAGE—/
ACUFF ROSE/ROBERT MELLIN—2 SONGS
TRANSATLANTIC MUSIKVERLAGE/
KARTHAL—2 SONGS

ONE SONG

BIRNBACH MUSIKVERLAG
EDITION ESPLANADE
MIKULSKI MUSIKVERLAG
IDEE MUSIKVERLAG
OKTAVE MUSIKVERLAG/SCHACHT
PEER MUSIKVERLAGE
PETER SCHAEFFERS/EUROPATON MUSIK-
VERLAGE

GERMANY—Recording Studios

Allach Studio, Zeiss Str 2 Allach, Munich
Rolf Bauer, Solitudenstr. 52, Ludwigsburg
Bavaria-Studio, Munich-Geiselsberg
Ton-Bild Technik, Bleichstr. 155, Bielefeld
Breuel-Film, Kirchenalle 57 (Klockmannhaus),
Hamburg
Caston Tonstudio, Liebigstr. 10A, Munich 22
Electrola-Studios, Maarweg 149, Cologne-
Braunsfeld
Esplanade-Festsale Tonstudio, Bellevuestr., Ber-
lin
Ernst Etzel Ateliers, Schweinheimstr. 93,
Aschaffenburg
Europa Studio, Goetbestr. 5, Stuttgart N.
Frankfurt Tonstudio, Zeppelinallee 38, Frank-
furt/Main
FTM-Produktion, Sanweiher, Baden-Baden
Hamburger Tonstudio Friedrich-Ebert-Halle,
Postweg, Hamburg-Harburg
Hamburger Werbenzentrale Krugmann & Am-
berg, Poststr. 31, Hamburg 36
Interradio, Bottergerstr. 15, Hamburg 13
"Ito" Institut fur Tontechnik, Bundesplatz 4,
Berlin-Wilmersdorf
H. Jansen & Co., Sudwest-Ton-Studio, Char-
lottenplatz 17, Stuttgart S.
Kurt Linnebach Film und Funkstudio, Kepe-
lerstr. 13, Munich 27
Meistersaal Tonstudio, Koetbenerstr., Berlin
Messehalle Tonstudio, Messestr., Cologne

Walter Nennig, Toningenieur, Grosse Bleichen
31, Hamburg 36
Robert Netekoven & Co., Wolfgangstr. 41,
Frankfurt/Main
Nettelkoven, Altes Funkhaus, Eschenheimer
Landstr. 33, Frankfurt/Main
Real-Film-Hamburg, Tonndorfer Hauptstr.,
Hamburg-Wandsbek
Riva-Studios, Munich-Unterschwaige
Hans Schneider Werbefunkstudio, Karl-Peters
Str. 13, Baden-Baden
777-Studio, Im Kirling 9, Rheinhausen-Hochem-
merich
Siemensvilla Tonstudio, Gartnerstr. 25-32, Ber-
lin-Lankwitz
Stellina, Sueddeutsches Telemusik und Ton-
studio, Am Biederstein 7, Munich 23
Teldec-Studio, Lichtenfelder Pestale, Finken-
steinallee 38-40, Berlin-Lichterfelde
Teldec-Studio, Osterstr. 124, Hamburg 19
Tempo-Studios, Rotwandstr. 16, Grossbesselohe/
Munich
Thinbaus Tonstudio, 'Elbchausee 499, Ham-
burg-Blankenese
Tonbild-Werbung, Rosenbuschstr. 6, Munich
22
UFA-Studios, Victoriastr. 13-18, Berlin
Villa Berg Tonstudio, Stuttgart
Joaquim Weigmann, Oberbergische tr. 3a,
Wuppertal
Wiesbaden Tonstudio, Wilhelmstr., Wiesbaden

IDEE MUSIC

Publishing & Production
Pop and Entertainment

Pohl Strasse 30
WEST BERLIN 30

GERMANY—Vital Statistics

POPULATION: (West Germany) Around 60 million with 19.2 million households
 PER CAPITA INCOME: 180 Dollars (720 marks) Monthly
 HOMES WITH RECORD PLAYERS: 8.0 Million

RECORD SALES—1964	1963	% Of Change	
Singles	23.3 Million	24.2 Million	- 3.7%
EP's	8.3 Million	8.4 Million	- 1.2%
10" LP's	1.5 Million	1.8 Million	-16.7%
12" LP's	9.9 Million	7.9 Million	+25.3%

The German phonograph Record Industry has released figures for the entire year of 1964 and the results show that once again singles went down and LP's zoomed up in sales. Dollar volume rose once again due to LP sales.

That means a huge increase in large LP sales. The large majority of sales were directly through record shops and divides itself in the following way.

Sales Through Record Shops	Category	1963	1964	% Change
	Singles	22.1 mil.	23.1 mil.	- 4.3%
	EP's	6.0 mil.	6.5 mil.	- 7.7%
	10" LP's	0.8 mil.	1.2 mil.	-33.3%
	12" LP's	8.0 mil.	5.9 mil.	+35.6%

The rest of the sales were through channels other than record shops and showed an increase of 9% in singles sales through this method, an increase of 21.1% in EP's, an increase of 16.7% in 10" LP's and a decrease of 5% in 12" LP's over 1963. The sales figures are not as happy as they look as these figures include low priced product as well and the tremendous surge of the low priced LP has accounted for much of the sales, meaning less dollar volume. The division of sales figures in pop and classical is also interesting. Here's how things looked.

Classical	1964	1963	% Change	Pop	1964	1963	% Change
Singles	0.8 mil.	0.7 mil.	+ 14.3	Singles	22.5 mil.	23.5	- 4.3
EP	2.8 mil.	2.5 mil.	+ 12.0	EP	5.5 mil.	5.9	- 6.8
10" LP	0.9 mil.	1.0 mil.	- 10.0	10" LP	0.6 mil.	0.8	-25.0
12" LP	4.3 mil.	3.7 mil.	+ 16.2	12" LP	5.6 mil.	4.2	+33.3

This shows that the classical LP dropped from 46.8% of LP sales to 43.4% which is still a substantial part of the LP business. Export wise, business continued to pick up. Here are the statistics there.

Export Business	Category	1964	1963	% Change
	Singles	4.9 mil.	4.5 mil.	+ 8.9
	EP	1.5 mil.	2.0 mil.	-25.0
	10" LP	0.3 mil.	0.3 mil.	-
	12" LP	5.6 mil.	4.1 mil.	+36.6

Production figures in total increased from 55.6 million in 1963 to 57.4 million pieces in 1964. Singles production remained unchanged at 28.8 million, EP production dropped from 11.8 million to 10.2 for a percentual loss of 13.6%, 10" LP's dropped from 2.5 million to 2.2 million for a loss of 12% and the big 12" LP increased from 12.5 million in 1963 to 16.2 million in 1964 for a 29.6% increase.

These figures show that this year 21.4% of all records produced here were exported against 19.6% for 1963. Export went down from 1.74 million pieces to 1.65 million for a loss of 5.2%. The happiest news of the season was the increased stereo sales for LP's as 16.2% of all record sales outside of singles which are not released here in stereo were in stereo against 9.4% in 1963. 12" stereo LP sales doubled from 1.4 million to 2.8 million in one year. Pop stereo sales increased 150% over last year. As good as these figures look, Germany is not in as good a position increase in dollar sales wise as the U.S. or England. One reason for the loss in singles sales is the increase in popularity of the tape recorder which sold about 342,000 recorders in 1960, 329,000 in 1961, 382,000 in 1962, 380,000 in 1963 and about 385,000 in 1964.

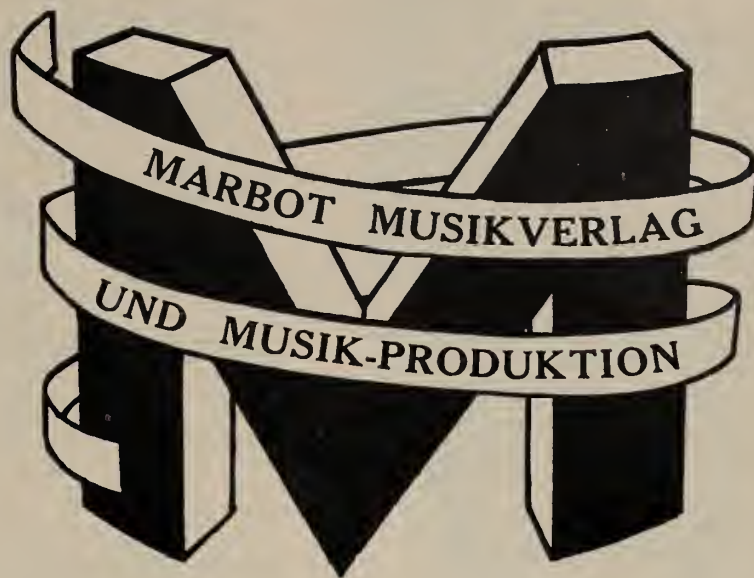

Thank You German D.J.'s and
 Record Shops for Over
 2 1/2 Million Records Sold from

RONNY

TELEFUNKEN RECORDS

- Kenn Ein Land • Kein Gold Im Blue River
- Darling Goodnight • Oh My Darling Caroline

EDITION MARBOT HAMBURG 13 BORNSTR. 72

TEL. 446606



BELMONT MUSIKVERLAG

GROSSKÖNIGSDORF bei KÖLN

Telephone FRECHEN 3961-2



IS THE PUBLISHING AFFILIATE OF

DEUTSCHE



SCHALLPLATTEN

GROSSKÖNIGSDORF bei KÖLN

Telephone FRECHEN 2025-6-7



WE CONSTANTLY NEED FRESH MATERIAL FOR 90 ARTISTS
 RECORDING FOR US IN GERMAN INCLUDING:-

PETULA CLARK • FRANCOISE HARDY • PAT BOONE •
 DIONNE WARWICK • BILLY VAUGHN • SANDIE SHAW • THE SEARCHERS •

RECORD-WISE DEUTSCHE VOGUE REPRESENT

U.S.A. DOT • KAPP • RED BIRD • SCEPTER

U.K. PYE

FRANCE VOGUE • AZ

ITALY DURIAM • SAAR • STYLE

WE ARE ALWAYS INTERESTED IN HOT MASTERS

call or write:-LARRY YASKIEL International Dept.; GROSSKÖNIGSDORF bei KÖLN.

NATIONAL RECORD LIBRARY, INC.

9278 SANTA MONICA BOULEVARD
BEVERLY HILLS, CALIFORNIA

Phone: (Area Code 213) 278-1090

CABLE: NATRECLIB Beverly Hills

LICENSORS for RECORDS and TAPES

Masters for Records, Pre-Recorded Tape, Cartridges and Background music available for license to most countries in the world.

Unexcelled library of many thousands of selections from the entire field of recorded music.

CLASSICAL ★ POPULAR ★
INTERNATIONAL
ORCHESTRAL ★
KIDDIES ★ DANCE ★
BIG BAND ★
INSTRUMENTAL, etc.

BUDGET LINES AVAILABLE

Negatives for four color artwork can be supplied.

Chart-Bound Singles can be placed in 25 different countries.

Information on repertoire and royalty rates available to established companies.

WE ARE INTERESTED IN
ACQUIRING OR REPRESENTING
OTHER CATALOGUES
THROUGH OUR WORLD WIDE
NETWORK OF AGENTS.

GERMANY—Record Producers, Manufacturers and National Distributors

ACONDOR RECORDS—Hamburg 13—Grindelhof 45 (Acondor)

ALPHA PRODUCTIONS—Eric von Aro—Wilmsdorfer Str. 94—Berlin—32 18 14

AMADEO RECORDS—Kassel, Germany (Acadeo, Vanguard)

AMFED RECORD PRODUCTIONS—Josef Raps Str. 1—Munich 23—32 64 10—Mal Son-dock

ABANOLA RECORDS—Nuernberg—Burg Str. 21 (Abanola)

ARIOLA SONOPRESS GMBH—Guetersloh/Westf.—Eickhoff Str. 14 Tel: 05241-3427 (Ariola, Athena, Barclay, Baccarola, Berthelmann, Scallplatten Ring, Cameo, Classique, Eurodisc, Manhattan, Parkway, Reprise, Laurie, Starday, Cetra, Hispavox, Karusell, Colpix, Kapp, Everest, 20th Fox, Bel Air, Fonit Fast, C. N. Rood)

AUSTROTON RECORDS—Diepholz/Hannover (Austroton, Elite, Special, Triola, Ricordi)

BOSTON RECORDS—Muehlheim/Ruhr (Boston, Pacific, Belcanto)

CONCERT HALL RECORDS—Frankfurt/Main—Gruneburg Weg. 9 (Concert Hall)

DEUTSCHE GRAMMOPHON GMBH—Hamburg 13—Harvestehuder Weg 1-4 Tel: 441421 (Archiv Produktion, Deutsche Grammophon, Coral, Brunswick, Decca, Helidor, United Artists, MGM, Cub, Cantate, Command, Italdisc, Verve, Polydor, Musicor, Big Top, Command, Dart Sales)

CBS SCHALLPLATTEN—Palmengarten Str. 4—Frankfurt/Main Tel: 775544 (Linda, CBS, Blue Note, Roulette, Artone, Chess, History, Cadence, Carina, Funckler, Checker, Palette, Candid)

DEUTSCHESCHALL PLATTEN—Darmstadt—Spree Str. 1—(Diskothek, Diskophon, Opera, DSG)

DEUTSCHE VOGUE RECORDS—Grosskoenigsdorf by Cologne (Vogue, Pye, Durium, Peacock, Duke, Seeco, Music, Clan, Red Bird, Riviera)

EGON DAVID RECORD—Cologne—Vogel-sanger Str. 165 (Tonika)

ELECTROLA RECORD CO.—Cologne—Braunsfeld—Maar Weg 149 Tel: 593131 (Electrola, Columbia, Capitol, HMV, Odeon, Parla-phon, Pathe, Liberty, EMI, Epic, Imperial)

EUROPAISCHER PHONOKLUB—Stuttgart 1—Schliessfach 1285—(Cottas, Gong, Opera)

FANAL RECORDS—Munich 2—Karl Str. 55 (Fanal)

KURT FELTZ, MUSIKPRODUCTION—Cologne—Drusus Gasse 7-11

FUTURA TON—Hannover—Frieden Str. 11 (Futura Ton) Peter Meisel

HANSA MUSIKPRODUCTION—W. Berlin—Wittelsbacherstr. 18 Tel: 914057

HOCHEDER & CO.—Dusseldorf—Wilhelm Marx Haus (Climax, Excelsior, Melojazz)

HOHNER RECORDS—9 Hohner Str.—Tross-inger/Wuerttemberg (Hohner)

IDEE PRODUCTION—Horst Fuchs—Berlin Berlin 30—Pohl Str. 58—13 46 58

ITALIA RECORDS—Sonnen Str. 20—Munich 15—Tel: 552621

JUPITER RECORDS—Munich 23—Am Bied-erstein 7 Tel: 385617 (Jupiter, Stellina)

P. P. KELEN RECORD CO.—Cologne—Hohen-zollern Ring 38/42—(Orbis, Pantheon, Parnass)

METRONOME RECORD CO.—Hamburg 1—Heidenkampsweg 76b—Tel: 241261 (Metronome, Atlantic, Golden 12, Atco, Prestige, Simon)

MILERNO—Handelstr. 39—Cologne

MILLER INTERNATIONAL—Hamburg—Spalding Str. 160—Tel: 543031 (Somerset, Sonodor)

MODERN MUSIC PRODUCTIONS—Franz Josef Str. 2—Munich 13

MONOPOL RECORDS—Wittelsbacher Str. 18—Berlin—Tel: 902345—(Monopol)

MONTE CARLO PRODUCTIONS—Musik-production Sud—Munich—Vienna

OSCA RECORDS—Rotwand Str. 16—Munich-Grosshesselohe—Tel: 794266 (Tempo, Osea)

PHILIPS TON GMBH—Hamburg 1—Moenne-berg Str. 7—Tel: 321017 (Philips, Fontana, Pergola, Vee Jay, ABC Paramount, Contem-porary, Goodtime Jazz, Riverside, World Pa-cific, Interdisc, Mercury)

PALLAS RECORDS—Diepholz/Bremen—Hind-enburg Str. 50 (Pallas, Dooley, Hohner, Meteor, Orchestrola)

PRO MUSIKA RECORDS—Stuttgart—Haupt-statter Str. 57 (Pro Musika)

RECO RECORDS—Frankfurt/Main—Jahn Str. 62—Tel: 595858—(Oriole, Embassy, Norman Petty Productions)

RING DER MUSIKFREUNDE—Postfach 1404—Cologne

777 RECORDS—Rheinhausen—IM Kirling 11—Postfach 36 (777)

SCHALLPLATTEN VERTRIEB MUENCHEN—Munich—Nymphenburger Str. 38 Tel: 550688 (Bella Musica, Superton, Starlet)

SCHALLPLATTENFABRIK SPEC.—Neurieder Str. 56—Munich 49

STUTTARTER HAUSBUCHEREI—Libanon Str. 3/5—Stuttgart

SUPRAHON—Hess Str. 39/41—Munich 13 (Supraphon)

TEFI WERKE GMBH—Porz/Cologne—Kolner Str. 8/12 (Tefi Tapes)

TELEDEC RECORD CO.—Hamburg 19—Heuss Weg 25—Tel: 401111 (Telefunken, Decca, Lon-don, Warner Bros., RCA, Dot, Sun, Imperial, Monument)

TERRA TON GMBH—Buederich/Dusseldorf—In Der Meer 9 (Arabella, Joker, Lasso, Terra, Viaphon, Voxim)

TIP RECORDS—Adolf Str. 58—Hamburg 22 (Tip)

TONSTUDIO CASTON—Liebig Str. 10A—Munich 22

TON KUNST VERLAG—Darmstadt/Eberstadt—Heinrich Delp Str. 273 (Cantate)

TON TREU RECORDS—Dusseldorf/Freili-grath Str. 24 (Ton Treu)

VOX-IMAGO RECORDS—Grosskoenigsdorf/Cologne—Frechen 2025 (Alfa, Imago, Imavox, Melos, Teddy, Vox)

FUNK RECORDS—C/O Otto Kuhl Verlag—Cologne, Am Hof 34/36—Tel: 212276

MACHINE SHOPS

M. Turchonski, Schlesische Str. 30, Berlin S. O. 36 Werner & Pfeiderer, Theodorstr. 10. Stuttgart-Feuerbach

MUSIC LICENSING ASSOCIATIONS

GEMA—Gesellschaft fur musikalische Auffuehrung und mechanische Vervielfaeltigungsrechte, Herzog-Wilhelmstr. 19, Munich
GVL—Gesellschaft zur Verwertung von Leis-tungsschutzrechten, Spichernstr. 55, Cologne

MATERIALS MILLING PLANTS

Deutsche Grammophon, Podbielskistr. 164, Hannover

Electrola, Marrweg 149, Cologne-Braunsfeld

Hildebrand & Richter, Kirchgellersen uber Luneburg 1

Ernst Kalkof, Gassner Allee 41, Mainz

Pallas-Schallplatten, Diepholz/Hannover

Teledec-Schallplatten Niedenstr., Nortorf

Karl Wenzel, Haptstr. 57, Orschweier/Baden

WILL MEISEL VERLAGE

Monopol Records

World Known • Own Records Label • Top Promotion



1 Berlin 31, Wittelsbacher Str. 18
Germany

GERMANY—Pressing Plants

Berliner Schallplatten-Fabrik, Metrophon, Königsallee 41, Berlin-Grünwald
 Calig Bildband, Werderstr. 6, Freiburg/Breisgau
 Deutsche Grammophon, Podbielskistr. 164, Hannover
 Electrola, Bismarckstr. 33, Berlin-Charlottenburg 4
 Hildebrand & Richter, Kirchgellersen über Luneburg
 Jano Studios, Kreuzstr. 76, Castrop-Rauxel 1
 Jazztone Society, Grunenburgweg 9, Frankfurt/Main
 P. P. Kelen, Hohenzollernring 38, Cologne
 Pallas, Postfach 186, Diepholz

Saarlandische Kondensatoren-Fabrik, Provinzialstr. 19, Brebach über Saarbrücken
 Saniphon-Heilton, Mommsenstr. 8, Berlin-Charlottenburg 4
 Sonopress, Eickhoffstr. 12, Gutersloh
 Special Record, Neuriedstr. 56, Munich 49
 Stahl, Kern Kahles & Co., Michelstadt/Odenwald
TELDEC
 Terra-Ton, Postfach 4 b, Düsseldorf-Buderrich
 Niedernstr., Nortorf
 Visaphon Bild Wort Ton-Methode, Turnseestr. 24-26, Freiburg/Breisgau
 Karl Wenzel, Hauptstr. 57, Orschweiler/Baden

GERMANY—Promotion

Etta Angeli, Tongesgasse 38, Frankfurt/Main
 Gunter Arendt, Fibigerstr. 339, Hamburg-Langenhorn
 Stephen von Baranski, Sonnenstr. 19, Ufahaus, Munich 15
 Gunther Braunlich, Heussweg 25, Hamburg 19
 Herbert Bremer, Schinkelstr. 15-17, Osnabrück
 Rudi Buttner, Kaltner Weg 4, Munich 25
 Oskar Feldkirchner, Planken 07,5, Mannheim
 Wolfam Gerbracht, Glashuttener Damm 92, Cologne/Lindenthal
 Hansi Hoffman, Goetrest. 13, Frankfurt/Main
 Angeborg Holubowsky, Sierichstr. 16 Hamburg
 Wolfgang Kretschmar, Monckebergstr. 7, Hamburg 1
 Kurt Ptach, Immenseeweg 15 D, Hamburg-Blahstedt
 Frau Reinicke, Harvestehuder Weg 1-4, Hamburg
 Siegfried Rothemund Nymphenburgerstr. 120 Munich
 Silvia Monika Schmager, Ritterstr. 24, Karlsruhe
 Tony Schwaegerl, Grabenstr. 5, Kulmbach
 Philipp Stocklein, Oberfohringer Str. 13, Munich 27
 Billy von der Tann, Hiltenspergerstr., Munich 13
 Ursula Tischer, Fuchsstr. 2, Munich 23
 Otto E. Tuppek, Planken 07, 5, Mannheim
 Mato Weiland, Strunzstr. 51, Munich
 Egon Wolf, Tondenstr. 39, Cologne-Bickendorf

POLYETHYLENE BAGS

Herbert Buttner, Schlierbergstr. 157, Freiburg/Breisgau
 Hans-Richard Dennert, Wichmannstr. 4, Hamburg/Grossflottbek
 Folienfabrik Forchheim, Zweibrückenstr. 15, Forchheim (Oberfr.)
 Gummiwerk Odenwald, Kaisrestr. 33, Frankfurt/Main
 Hilbert-Plastic, Alwin Hilbert, Hochstr. 22, Wattenscheid
 E. Horn Kunststoff, Grossheppach über Waiblingen
 Klein & Hartmann, Lutzowufer 12, Berlin W. 15
 Herbert Kleist, Oranienstr. 20, Berlin S.O. 36
 Kolwi-Burobedarf, Hoorwiese 5, Morsbach/Sieg
 Kunststoffverarbeitung Luneburger Heide, Bulgrin & Co., Marktstr. 36, Soltau (Han)
 G. Lachenmaier, In Laisen 34, Reutlingen
 Paja Verpackung, Hoffnungsthal/Cologne
 Otto Rechenberger, Grafenberger Allee 91, Düsseldorf
 Gebhard Riegger, Guterbahnhof, Ditzingen/Württemberg
 Eugen Romminger, August-Bebelstr. 13, Frankenthal/Pfalz
 Manfred Rothe, Togostr. 46, Munich 59
 Saarplatic, Am Kieselhumes 8, Saarbrücken
 Edich Schumm, Siegelsberger Str. 17, Murrhardt/Württemberg
 S. E. Seiler & Co., Kunststoffwerk, Neumühle Post Diespeck
 Karl H. Sengewald, Kuensebeck (Bielefeld)
 F. Soennecken, Kirschallee 1, Bonn
 Star-Notenschreibpapier, Gutschowstr. Eberbach (Bad Neckartal)
 Sudbadische Mappenfabrik, Bierich-Riedel & Co., Oststr. 13, Kehl
 F. E. Walter, Nordfelder Reihe 21, Hannover
 Württembergische Allplastik, Plastik-Spritzgusswerk, Wallgraben 151, Stuttgart-Vaihingen

GERMANY—

Label Manufacturers

H. Beer, W. Dietrichstr. 14, Munich 19
 Billetfabrik, Ostengasse 34, Regensburg
 Brenner & Stangelmeier, Pfarrweg 30, Munich 9
 Walter Bundschuh, Stephanienufer 2, Mannheim 1
 Karl Dobler, Ziegelstr. 16, Ravensburg
 Josef Ertl, Schmellerstr. 11, Munich 12
 Etiketten Schreiner, Wilhelm-Mayr Str. 11, Munich 42
 Etiketten und Stahlstichdruck, Pflinganserstr. 132, Munich 25
 Eukerdruck, Steinweg 35a, Marburg (Labn)
 Goedicke, Landwehstr. 289, Hannover
 Karl Gramlich, Schmidstr., Pliezhausen/Württemberg
 Gutenberg Druckerei Mainz, Reich-Klara Str. 10, Mainz
 Gehr. Haertl, Adlzeiterstr. 18, Munich 15
 Gabr. Heichlinger, Hansastr. 181, Munich 25
 Wilhelm K. Homa, Jabnstr. 10, Memmingen
 Hugle & Rehm, Hollstr. 1, Radolfzell (Bodensee)
 Klein & Volbert, Bottingerstr. 94, Munich
 Bernhard Theodor Kolle Nachf., Offelter Weg 113, Preussisch Oldendorf/Westf.
 Hans Kropf, Vorstadt 27, Mitterteich
 K. Laufer, Friedrich-Karl Str. 4, Mannheim
 Karl Linnepe, Lutherstr., Ludenscheid
 Hans Marquardt, Prinzenweg 11a, Regensburg
 O. Maubach, Weinbergstr. 1, Mainz-Mombach
 Munchberg-Helmbrechtser Zeitung Bahnhofstr. 19, Munchberg
 Ludwig Noltemeyer, Hildesheimer Str. 65, Braunschweig
 Offsetdruckerei Marianne Blattner, Rumfordstr. 18, Munich 5
 H. Prickarts, Weinbergstr. 1, Mainz-Mombach
 Druckerei Proppe, Neumunster
 G. Putz, Planeggerstr. 16, Munich
 Emil Rapp, Banddruckerei, Mohringen/Baden
 Schagen & Eschen, Lurriper Str. 14, Monchen-Gladbach
 Ludwig Schmidt, Dielinger Str. 10-11, Osnabrück
 Ch. Seitz, Rollbuhlstr. 61a, Mannheim-Kafertal
 Franz X. Seitz, Rumfordstr. 23, Munich 5
 Gebr. Seuster, Etikettenfabrik, Plattenberg-Holthausen
 Streckel & Co., Kapellenstr. 36, Rastatt
 Karl Theysler, Druckerei, Mainz
 L. F. Thomas, Lehmgweg 36, Plattenberg Holt-hausen
 K. Unterholzer, ImPferstr. 51, Munich 25
 Vereingte Offsetdruckereien, Mannheim-Nec-karau
 Gebruder Voit, Postfach, Nurnberg 16

Germany's leading
 One-Stops and record
 dealers (30 outlets in all)
 have banded together
 to form
TRANSATLANTIC
 Music Publishing

WE NEED:
 Top foreign hits
 Catalogue Deals
WE WANT
 to place our top hits
 in the U.S.A.
 and other foreign countries.

Contact
Transatlantic
Musikverlag
GmbH.

Managing Director: Karl Karthal
 6 Frankfurt/Main
 Schleusenstr. 18

GERMANY'S TOP 10 CHART LP's—JANUARY-JUNE

(Listed in order of appearance. Not in order of sales)

- *MY FAIR LADY—ORIGINAL GERMAN CAST—PHILIPS
- *DIE SPITZENREITER 1964 (The top hits of 1964)—VARIOUS ARTISTS—POLYDOR (D.G.G.)
- *WEST SIDE STORY—ORIGINAL SOUNDTRACK—CBS
- *BEATLES FOR SALE—THE BEATLES—ODEON (ELECTROLA)
- *YEAH, YEAH, YEAH (A HARD DAY'S NIGHT)—THE BEATLES—ODEON (ELECTROLA)
- *KENNETH SPENCER IN MEMORIAM—COLUMBIA (ELECTROLA)
- *THE ROLLING STONES—DECCA (TELDEC)
- *SPAZIERGANG DURCH DAS LAND DER OPERETTE (A stroll through the land of Operetta)—PETER ALEXANDER—POLYDOR (D.G.G.)
- *NOCH FRECHERE CHANSONS AUS DEM ALTEN FRANKREICH (Even spicier Chansons from old France)—HELEN VITA—DEUTSCHE VOGUE
- *PLAY BACH NO. I, II, III, IV—JACQUES LOUSSIER—DECCA (TELDEC)
- *AROUND AND AROUND—THE ROLLING STONES—DECCA (TELDEC)
- *WIENER SPAZIERGÄNGE (Vienna Strolls)—PETER ALEXANDER—POLYDOR (D.G.G.)
- *SCHLAGER DES JAHRES (Hits of the year)—VARIOUS ARTISTS—HOER ZU (TELDEC-ELECTROLA)
- *SONGS DER WELT (Songs of the world)—ESTHER & ABI OFARIM—PHILIPS
- *HUMBA-HUMBA TAETAERAE (Carnival songs)—VARIOUS ARTISTS—POLYDOR (D.G.G.)
- *HILDEGARD KNEF: DIE GROSSEN ERFOLGE—(The big hits of Hildegard Knef)—DECCA (TELDEC)
- *THE KINKS—DEUTSCHE VOGUE
- *MELODIE EINER NACHT (Melody of a night)—ESTHER & ABI OFARIM—PHILIPS
- *DIE GROSSE STARPARADE 1965 (The big star parade)—VARIOUS ARTISTS—POLYDOR (D.G.G.)
- *BEATLES 1965—THE BEATLES—ODEON (ELECTROLA)
- *EIN ABEND MIT FREDDY—(An evening with Freddy)—FREDDY QUINN—POLYDOR (D.G.G.)
- *DON'T HA HA—CASEY JONES & THE GOVERNORS—GOLDEN 12/METRONOME

OUR ACTIVITY = YOUR SUCCESS



CAPRICCIO

managed by Peter Lach

Capriccio Musikverlag — 2 Hamburg I

Mönckeberg Str. 5 Tel: 334096 Cable: Caprimusik-Hamburg

EDITION ACCORD

Already representing such important catalogues as:

Aaron Schroeder Music Corp. and its
 subsidiaries—U.S.A.

Saturday Music Inc.—U.S.A.

Web IV (Bert Berns)—U.S.A.

Filmusic—England

HOW ABOUT YOUR CATALOG OR
 TOP HIT FOR "65" FOR GERMANY?

WE ANNOUNCE A CHANGE OF OFFICE ADDRESS TO:

HOHENSTAUERNRING 63

COLOGNE, GERMANY

TEL: 23 80 67

WORLD WIDE MUSIC TRADE DIRECTORY

(Continued from page 23)

MANUFACTURAS AJOVER—Apartado Aereo 4911—BOGOTA
(Calle 19 No. 14-40—Bogota)
Phone: 429785
Cable: AJOVER BOGOTA
Pres.: Mr. Alberto J. Verswyvel
Labels (domestic): AJV, Montilla
Labels (others): Command, Decca, Dot, Grand Award, Kapp, Telefunken, Vox, Zaphiro.

ONDINA FONOGRAFICA COLOMBIANA LTDA.—Apartado Aereo 915—MEDELLIN
(Calle 67-A No. 51-D-23—Medellin)
Phone: 41000, 43333
Cable: ONDINA MEDELLIN
Pres.: Mr. Rafael Acosta Salinas

SOCIEDAD NACIONAL DE MUSICA, SONOMUSICA—Apartado Aereo 1263—MEDELLIN
(Carrera 64 D. No 104-130—Entrada por Zemú—Autopista Norte—Medellin)
Phone: 51825, 21883
Cable: SILVER MEDELLIN
Pres.: Mr. Orlando Posada Gonzalez
Labels (domestic): Conmusica, Preludio, Silver, Sonomusica
Labels (others): Discomoda, Gema, Giron, Puchito, Serenata, Velvet

CONGO

FIRME JERONIMIDIS-NGOMA—Boite Postale 74—LEOPOLDVILLE
Phone: 2396
Cable: JERONIMIDIS LEOPOLDVILLE
Pres.: Mr. N. Cavadias
Labels (domestic): Ngoma

MACODIS S.C.P.R.L.—Boite Postale 433—LEOPOLDVILLE
(Boulevard Léopold III—13° rue—Leopoldville)
Phone: 7331
Cable: MACODIS LEOPOLDVILLE
Pres.: Mr. E. W. Pelgrims de Bigard, Brussels
Mgr.: Maurice Jeandrain
Labels (domestic): African Jazz, O.K. Jazz, Surbom

COSTA RICA

INDUSTRIA DE DISCOS CENTROAMERICANA LTDA.—Apartado 1645—SAN JOSE
(Avenida 8 entre Calles 11 y 13—San José)
Phone: 1931
Cable: INDICA SANJOSE
Pres.: Mr. Oscar Stupp K.
Labels (domestic): Indica
Labels (others): Capitol, CBS, Dot, Warner Bros.

REUBEN & CO., LTD.—Apartado 547—SAN JOSE
(Calle 1ª Avenida 1/3—San José)
Phone: 4354
Cable: REUBEN SANJOSE
Gen. Sales Mgr.: Mr. Teodoro Reuben-Aguilera
Labels (domestic): Alma Tica
Labels (others): Alegre, America, Ansonia, ART, Audio Fidelity, Decca, Dimsa, Discomoda, Epic, Falcon, Fuentes, Gamma, Kapp, Kubaney, London, Medallion, Mercury, Miami, Montilla, Musart, Odeon, Orfeon, Peerless, Polydor, Puchito, RCA Victor, Seeco, Sonolux, Sonus, Telefunken, etc.

CUBA

ASOCIACION EDITORIAL MUSICABANA—Campesano 151—HAVANA
Phone: 61-0948
Pres.: Mr. Alberto Vera Morua

CYPRUS

D. OUZOUNIAN, M. SOULTANIAN & CO., LTD.—P.O. Box 775—NICOSIA
(145 Evagoras Avenue—Nicosia)
Phone: 2220
Cable: AUTOMOBILES NICOSIA
Chairman: Mr. M. Soutlianian
Labels (domestic): Philips
Labels (other): CBS, Fidelity, Fontana, Mercury, Odeon Fidelity, Vogue.

CZECHOSLOVAKIA

ARTIA—P.O. Box 790—PRAGUE 1
(Ve Smečkách 30—Prague 1)
Phone: 246-266, 246-284, 246-238
Cable: ARTIAGRAMO PRAGUE
Man. Dir.: Mr. Boris Grund
Only organization to be contacted in questions of export or import of ready-made cultural goods (records and sheet music editions).

PANTON NAKLADATELSTVI SVAZU CESKOSLOVENSKYCH SKLADATELU (PANTON PUBLISHERS OF THE GUILD OF CZECHOSLOVAK COMPOSERS)
Besedni 3—PRAGUE 1
Phone: 533-832
Pres.: Mr. Jan Hanus
Slovakian branch office: Sládkovicova 11—Bratislava

STATNI HUBEJNI VYDAVATELSTVI, n.p.—1, Pa-lackého—PRAGUE 1
Phone: 249-251
Cable: SUPRAPHON PRAGUE
Pres.: Dr. Vojtech Strnad

STATNI HUBEJNI VYDAVATELSTVI, n.p.—1, Pa-lackého—PRAGUE 1
Phone: 249-251
Cable: SUPRAPHON PRAGUE
Pres.: Dr. Vojtech Strnad

STATNI HUBEJNI VYDAVATELSTVI, n.p.—1, Pa-lackého—PRAGUE 1
Phone: 249-251
Cable: SUPRAPHON PRAGUE
Pres.: Dr. Vojtech Strnad

STATNI HUBEJNI VYDAVATELSTVI, n.p.—1, Pa-lackého—PRAGUE 1
Phone: 249-251
Cable: SUPRAPHON PRAGUE
Pres.: Dr. Vojtech Strnad

DAHOMEY

RECORD MFRS

ALA COQUETTE—Carré 85 Avenue Monseigneur Steinmeitz—COTONOU
Cable: AYEDADJOU COQUETTE COTONOU
Pres.: Mr. Paul Ayédadjou
Labels (domestic): Senafone
Labels (others): Badojo's, Columbia, Decca, Olu-tone, Parlophone.

RADELEC—Boite Postale 179—COTONOU
(Avenue Delorme—Cotonou)
Phone: 2721
Cable: RADELEC COTONOU
Pres.: Mr. Théodore Ahuissoussi
Own import of most international labels.

DOMINICAN REPUBLIC

MUSIC PUBLISHERS

PEER INTERNACIONAL DOMINICANA—Apartado Postal No 210—SANTO DOMINGO
(Calle El Conde No 24, 3er piso—Apartamientos Nos 305 & 307—Santo Domingo)
Phone: 9-7939
Cable: PEERDO SANTODOMINGO
Mgr.: Mr. Manuel Troncoso

RECORD MFRS

AGENCIA MUSICAL DISCOLANDIA—Avenida Juan Pablo Duarte No 47—SANTO DOMINGO
Phone: 2-5714
Cable: DISCOLANDIA SANTODOMINGO
Pres.: Mr. Manuel B. Sater B.
Labels (domestic): Discolandia
Labels (others): Capitol, Columbia, RCA Victor, Seeco, etc.

AMARO DISCOS—Apartado 1270—SANTO DOMINGO
(Avenida Duarte Esquina Bonito Gonzales—Santo Domingo)
Phone: 2-6718
Cable: AMARODIS SANTODOMINGO
Pres.: Mr. Francisco Amaro Rodriguez
Labels (domestic): Amaro, Perla
Labels (others): Ansonia, Marvela, Riney

ECUADOR

RECORD MFRS

ALMACENES DE MUSICA C.A.—Casilla 856—GUAYAQUIL
(Avenida 9 de Octubre 428—Guayaquil)
Phone: 12648, 13932
Cable: DOFERAUD GUAYAQUIL
Pres.: Mr. Jose Domingo Feraud Guzman
Labels (domestic): Onix
Labels (others): Discomoda, Gema, Music-Hall

COMPANIA ANONIMA INDUSTRIAL FONOGRAFICA ECUATORIANA—Apartado 84—QUITO
(Venezuela 693—Quito)
Phone: 11919
Cable: CAIFE QUITO
Pres.: Mr. Carlos Rota
Labels (domestic): Caife, RCA Victor
Labels (others): Cetra, CRC, Discuba, Sonolux, and about 20 others.
Branch offices in Guayaquil and Cuenca

CORPORACION INDUSTRIAL FONOGRAFICA S.A.—Casilla No 2152—QUITO
(Edificio Guerrero—Quito)
Phone: 38045
Cable: CORSA QUITO
Pres.: Mr. Hector Vela Vega
Labels (domestic): Corsa
Factory at Avenida Miraflores 2, Ambato.

EMPORIO MUSICAL S.A.—Casilla 1276—GUAYAQUIL
(Lorenzo de Garaioca 2803 y Maldonado—Guayaquil)
Phone: 14174
Cable: EMPORMUSIC GUAYAQUIL
Pres.: Mr. Carlos Pino Plaza
Labels (others): CBS

INDUSTRIA FONOGRAFICA ECUATORIANA S.A.—Apartado 3885—GUAYAQUIL
Phone: 14102, 14103
Cable: IFESA GUAYAQUIL
Pres.: Mr. Jeronimo Aviles Alfaro
Labels (others): Hispavox, Mercury, Musart, Odeon, Ondina, Peerless, Sonradie

PHILIPS ECUADOR C.A.—Casilla 343—QUITO
(Avenida Patria 792—Quito)
Phone: 30064
Cable: PHILRADIO QUITO
Gen. Man.: Mr. Henri Gazan
Labels (others): Deutsche Grammophon, Fontana, Mercury, MGM, Philips, Polydor, United Artists.

PRODUCCIONES FONOGRAFICAS RECALDE—Casilla 2001—QUITO
(Calle Bolivar 212—Quito)
Phone: 12820
Cable: TRECALDE QUITO
Pres.: Mr. Trajano Recalde C.
Labels (domestic): Fuentes, Rondador, Seeco.

INDUSTRIA FONOGRAFICA ECUATORIANA S.A.—Apartado 3885—GUAYAQUIL
(Rumichaca y Calicuchima Esquina—Guayaquil)
Phone: 14102, 14103
Cable: IFESA GUAYAQUIL
Pres.: Mr. Geronimo Aviles Alfaro

EL SALVADOR

RECORD MFRS

CASA RIVAS—Calle Ruben Dario 708—SAN SALVADOR
Phone: 2915
Cable: CASARIVAS SANSALVADOR
Pres.: Mr. Rafael Rivas P.
Labels (domestic): Kismet
Labels (others): Capitol, CBS, Polydor, RCA Victor, etc., etc.

ETHIOPIA

RECORD MFRS

CENTRAL MUSIC HOUSE—P.O. Box 1775—ADDIS ABABA
(Haile Selassie Square—Addis Ababa)
Phone: 11093
Pres.: Mr. Vittorio Tamborrino
Labels (others): Barclay, Bel Air, Capitol, CGD, Columbia, Durium, Electrola, Festival, His Master's Voice, Jolly, Made, Odeon, Parlophone, Pathé, Pop, RCA Italiana, RCA Victor, Stateside, Vogue, Warner Bros.

FIJI ISLANDS

RECORD MFRS

MORRIS HEDSTROM LTD.—P.O. Box 295—SUVA
(Thomson Street—Suva)
Phone: 3002
Cable: DEUBA SUVA
General mgr.: Mr. D. Crowe
Labels (domestic): Tapa, Viking
Labels (other): Capitol, Columbia, Decca, His Master's Voice, London, Parlophone

WM. BRECKWOLDT & CO.—P.O. Box 369—SUVA
(McGowan's Building—Suva)
Phone: 3254
Cable: BREWO SUVA
Pres.: Mr. Friedrich Wilhelm Breckwoldt
Labels (others): Archiv-Produktion, Deutsche Gram-mophon, Polydor

FORMOSA

RECORD MFRS

LINFAR ENGINEERING & TRADING LTD.—No 9, Lane 4, Shanghai Road, 1 Sec.—TAIPEI
Cable: LINFAR TAIPEI
Pres.: Mr. Linfair F. F. Chang
Labels (domestic): Union
Labels (others): All Decca Group of labels

NEW VOICE RECORDS CO.—3 Minchiang Road—LUKANG—Changhwa
Phone: Lukang 318
Cable: NEWVOICE LUKANG
Pres.: Mr. C. C. Wang
Labels (domestic): New Voice

QUEEN RECORDS MANUFACTURING CO. LTD.—70, Fuh-teh S. Road—SAN-CHON CITY—Taipei Hsien
Phone: Taipei 97-126
Cable: QUEENCO TAIPEI
Pres.: Mr. John Y. Yang
Labels (domestic): Queen

UNIVERSAL RECORDING CO., LTD.—P.O. Box 694—TAIPEI
(256, Hsi Yuan Road, Section 2—Taipei)
Phone: 33-993
Cable: UNIVERECOD TAIPEI
Pres.: Mr. Hanslin Huang
Labels (domestic): Globe

GERMAN DEMOCRATIC REPUBLIC

RECORD MFRS

VEB DEUTSCHE SCHALLPLATTEN—Reichstagufer 4/5—BERLIN W.8
Phone: 22 50 71
Cable: SCHALLPLATTEN BERLIN
Pres.: Mr. Harri Költzsch
Labels (domestic): Amiga, Eterna, Litera

GHANA

RECORD MFRS

BHOJONS & CO. (GHANA) LTD.—P.O. Box 1531—ACCRA
(D959/3 Knutsford Avenue—Accra)
Phone: 64488
Cable: BHOJONS ACCRA
Pres.: Mr. M. B. Mahtani
Labels (domestic): Decca
Labels (others): Angel, Columbia, His Master's Voice, Parlophone and all other EMI brands.

GREECE

COLLECTING SOCIETIES

A.E.P.I. SOCIETE ANONYME HELLENIQUE POUR LA PROTECTION DE LA PROPRIETE INTELLECTUELLE—7 Botassi Street—ATHENS
Phone: 629.730
Cable: DAX ATHENS
Pres.: Mr. Gregoire Constantinides
Collecting Society for Mechanical Licenses

MUSIC PUBLISHERS

MAISON DE MUSIQUE PHILIPPE NAKAS—2 Rue Harilaou Trikoupi—ATHENS
Phone: 612.720
Cable: NAKASFIL ATHENS
Pres.: Mr. Philippe Nakas

MICHAEL GAETANOS—10, Stoa Arsakiou—ATHENS
Phone: 222.876
Cable: MIGAETANOS ATHENS
Pres.: Mr. Michael Gaetanos

POPULAR MUSIC AND RECORDS—Themistocleous-Aristidou—ATHENS
Phone: 843.230
Cable: POPULARECORD ATHENS
Pres.: Mr. Evans Plomariis

RECORD MFRS

GREEK PHONOGRAPH RECORD HOUSE—Platia Kolokotroni 3—ATHENS
Phone: 231.533, 233.069
Cable: GEORPH ATHENS
Pres.: Mr. Georgios Orphanidis
Labels (domestic): RCA Victor
Labels (others): Aristocrat, Carisch, Fonit, Hickory, Imperial, Melophone, Pathé, Telefunken, United Artists

HELLADISC S.A. GRAMOPHONE RECORDS CO.—Ermou Street 8—ATHENS
Phone: 238.291/3
Cable: HELLADISC ATHENS
Pres.: Mr. Nikolas Antipapas
Labels (domestic): Fidelity, Philips, Polydor
Labels (others): Archiv-Produktion, Atlantic, Audio Fidelity, Barclay, Cameo/Parkway, Coral, Deutsche Grammophon, Fontana, Heliodor, Kapp, Mercury, Polydisc, Riverside, Roulette, United Artists.

LAMBROPOULOS BROS., LTD.—8B, Lykourgou Street—ATHENS
Phone: 527.168, 527.287
Cable: ADELAMBRO ATHENS
Pres.: Mr. Xenophon Lambropoulos
Labels (domestic): Columbia, His Master's Voice
Labels (others): ABC-Paramount, Capitol

MELODY RECORDS CORP.—11 Aristidou—ATHENS
Phone: 227.329
Cable: MELODY ATHENS
Pres.: Mr. Anthony Plomariis
Labels (domestic): Athenee, Melody, Popular
Labels (others): Artone, Cetra, Combo, Embassy, Everest, Festival, Meazzi, Pacific, Rifi, Ronnex, Simco, Sonet, Teeny, Variety, Vedette, Zafiro.

MINOS MATSAS & SON—48, Stadiou Street—ATHENS
Phone: 288.660
Cable: ODEOPARLOPHONE ATHENS
Pres.: Mr. Minos Matsas
Labels (domestic): Odeon, Parlophone
Labels (others): Warner Bros.

MUSIC-BOX—2, Nikis Street—ATHENS 126
Phone: 221.574
Cable: THOMS ATHENS
Pres.: Mr. Martin Th. Gesar
Labels (domestic): Decca, Music-Box
Labels (others): Ariola, Bruno Hi-Fi, Canadian-American, CBS, Colpix, Dot, Durium, Harmonia Mundi, Hispavox, Liberty, London, M.G.M., Motown/Tamla, Palette, Societe Française du Son, Stateside, Telefunken, Vogue.

GREENLAND

Geographically a part of the American continent, politically a part of Denmark. Local recordings are made by some leading manufacturers, among others, EMI, and by below company:

RECORD MFRS

GRONLANDS INKOBRING A/S—Vesterbrogade 60 A—COPENHAGEN V (Denmark)
Phone: EVA 1561
Cable: RINGBUY COPENHAGEN
Pres.: Mr. Ole Flønsted
Labels (domestic): Kajak

GUATEMALA

RECORD MFRS

CASA MUSICAL—13 Calle 9-62, Zona 1—GUATEMALA CITY
Phone: 29645
Cable: MUSICAL GUATEMALA
Pres.: Ing. M. R. Wunderlich
Labels (domestic): Iximché
Labels (others): Columbia, Capitol, RCA Victor

GRABADORA TIKAL—18 Calle 3-60, Zona 1—GUATEMALA CITY
Phone: 28545
Cable: TIKALSA GUATEMALA
Pres.: Mr. Salvador Avelar G.
Labels (domestic): Tikal, Tirosa

SEXTA AUTO VIA—6ª Avenida 12-15, Zona 1—GUATEMALA CITY
Phone: 22330
Cable: AUTOVIA GUATEMALA
Pres.: Mr. Haroldo Castillo Obregón
Labels (domestic): Ayarza, Exitos, Maya, Romendy, Utiatán
Labels (others): among others Gamma, Kismet, Montilla, Musart, Orfeón, RCA Camden, Seeco, etc.

HAITI

RECORD MFRS

ANSON MUSIC CENTER—62, Rue Pavée—PORT-AU-PRINCE
Phone: 3252, 3272
Cable: MUSICCENTER PORTAUPRINCE
Mgr.: Mr. Joe G. Anson
Labels (domestic): Ibo, Palace, Quisqueya
No foreign labels under exclusive contract, but has the leading American, French and Mexican labels in stock for sale.

HONDURAS

RECORD MFRS

CASA CARLOS A ZUÑIGA—Apartado C-32—TEGUCIGALPA, D.C.
Phone: 11-63
Cable: ZUNCO TEGUCIGALPA
Pres.: Mr. Carlos A. Zuñiga
Labels (domestic): Carrousel
Labels (others): Ansonia, Capitol, Musart, Peerless, RCA Victor, Seeco.

HONG KONG

RECORD MFRS

ELECTRIC & MUSICAL INDUSTRIES (HONG KONG) LTD.—P.O. Box 14694—HONG KONG
(305 The Chartered Bank Building—Hong Kong)
Phone: 31271
Cable: EMITRON HONGKONG
Gen. Mgr.: Mr. Ted Inslay
Labels (domestic): Columbia, Pathé (Chinese)
Labels (others): Epic, Laurie, Rendezvous, Scepter, Sonet, Wand.

GODDARD & CO., LTD.—P.O. Box 3000—HONG KONG
(103, Victory House—Wyndham Street—Hong Kong)
Phone: 37996, 21708
Cable: GEODACO HONGKONG
Man. Dir.: Mr. George Ho
Agency for: CBS, Mercury, Philips, Riverside

JARDINE MATHESON & CO., LTD.—P.O. Box 70—HONG KONG
(Jardine House—22, Pedder Street—Hong Kong)
Phone: 35911
Cable: JARDIMPO HONG KONG
Labels (domestic): Angel, Columbia, Odeon, Pathé
Labels (others): Capitol, Encore, His Master's Voice (for Macao only), Parlophone, Stateside, Warner Bros.

MOUTRIE & CO. (HONG KONG) LTD.—P.O. Box 404—HONG KONG
(Alexandra House—Chater Road—Hong Kong)
Phone: 31372, 20527
Cable: MOUTRIE HONGKONG
Mgr.: Mr. E. W. Smith
Labels (others): CBS, Mercury, Philips, Riverside

(Continued on Pg. 69)

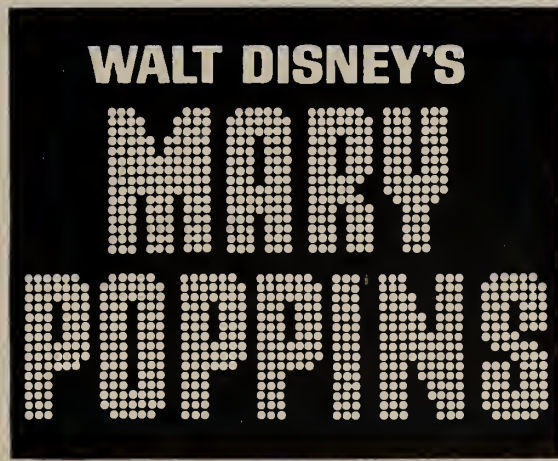

FLYING TO NEW RECORD HEIGHTS ALL AROUND THE WORLD

THE ORIGINAL CAST SOUND TRACK LP
IS THE BEST-SELLING ALBUM
OF 1965 IN AMERICA

Here are the lucky Disney phonograph record licensees
in the countries where 'MARY POPPINS' is now set to play

Argentina	Phonogram S.A.I.C.	Buenos Aires	Jan. 1966
		Mar del Plata	Jan. 1966
Australia	E.M.I. Australia Ltd.	Sydney	May 1965
Austria	Electrola	Vienna	Dec. 1965
Belgium	Vista	Brussels	Oct. 1965
Brazil	RCA Electronica Brasileira	Sao Paulo	Dec. 1965
Chile	Corporacion de Radio de Chile S.A.	Santiago	Sept. 1965
Colombia	Manufacturas Ajoover	Bogota	Oct. 1965
Costa Rica	RCA Victor Mexicana	San Jose	Sept. 1965
Denmark	Skandinavisk Grammophon	Copenhagen	July 1965
England	E.M.I. Records (Gramophone Co. Ltd.)	London	Jan. 1965
Finland	OY R.E. Westerlund AB	Helsinki	Sept. 1965
France	Vista	Paris	Oct. 1965
Germany	Electrola	Berlin	Oct. 1965
Guatemala	RCA Victor Mexicana	San Jose	Sept. 1965
Holland	Bovema	Amsterdam	Dec. 1965
		The Hauge	Dec. 1965
		Rotterdam	Dec. 1965
Italy	Vista	Rome	Oct. 1965
		Milan	Oct. 1965
New Zealand	His Master's Voice (N.Z.) Ltd.	Auckland	Aug. 1965
Peru	El Virrey S.A.	Lima	July 1965
Portugal	Hispavox S.A.	Lisbon	Dec. 1965
South Africa	Brigadiers (PTY) Ltd.	Johannesburg	June 1965
		Pretoria	June 1965
		Capetown	June 1965
		Durban	June 1965
		Port Elizabeth	June 1965
Sweden	Skandinaviska Grammonphon	Stockholm	Aug. 1965
Switzerland	Vista	Zurich	Oct. 1965
Venezuela	Venevox, c.a.	Caracas	June 1965

FRANCE - The Past Twelve Months

The past year has not been a very good period for record manufacturing in France. It is the first time since 1961 that record turnover did not progress. But the situation is not really grave. The crisis is normal after the crazy Yéyé years, and is supported by the French "Plan de stabilisation."

Actually French talent scouts try to find new authors and composers. The way is shown by new stars Salvatore Adamo, Enrico Macias and France Gall. Salvatore and Enrico write their songs and the France's father is Robert Gall a well known author. A new young singer has to write his own songs or to have his own composers. All Americans and English top hits are swept up by artists like Johnny Hallyday, Claude François, Richard Anthony, Sheila, Françoise Hardy or Eddy Mitchell. It is impossible for a young singer to have a good foreign song.

This summer will surely give a new start to the record industry in France.

OCTOBER

For the occasion of Dave Brubeck's quartet's first appearance in Paris, CBS released on the French market two 12 inch LP's of this group entitled "Time Changes" and "Impressions of Japan." On the Odeon label, we have The Beatles with an excellent disk, including the principal songs from their recent film. Vogue has released several novelties, Dean Martin's "A Little Voice," The Dixie Cups "A Girl Can't Tell." An importance on the French market is for the moment the American and English singers. We have Dionne Warwick, which after a successful performance at the Olympia Music Hall in Paris, recorded some songs in France for Vogue Records. Also the Austrian singer Udo Jurgens supplies us in French with "Si Tu Par-

tous" and "Crois Moi." On the subject of the music hall, Los Indios Tabajaros obtained an immense success during their appearance at the Olympia Music Hall. There has been released a good grooving by John Foster with main title "Amore Scuisami." Bobby Solo's best song seems to be "Ore Che Scigia Una Donna." Concerning Marie Laforet, she obtained a great success by "Viens Sur La Montagne." The young lark France Gall, has released a new disk, "Laisse Tomber Les Filles." A new fact on the French disk market is a big collection with 2, 3, 6 or 10 records. After following a success made by Philips, RCA Victor released a 10-LP package called "Panorama de la Chanson Francaise" including 16F popular French songs. Also, Columbia followed with a 10-LP set of well known Edith Piaf songs. At the Chatelet Theater, Radio-Luxembourg presented a show with Sacha Distel and the two Italian stars Bobby Solo and Gigliola Cinquetti. By his first performance at the Olympia Music Hall, Jacques Brel had quite a triumph and a live recording was made during the concert. Richard Anthony has been in London recording a new EP for Columbia. Good news for Barclay is that Charles Aznavour has come back from New York City just to renew his agreement with the label till 1970. In New York Aznavour organized the American office of French Music. His records will, from now on, be distributed by Reprise Records. Leon Cabat, Vogue's Prexy, is also back from the States. He informs us that the publishing firm Vogue International is not only working for Vogue Records; it will represent in France: Dot, Billy Vaughan, Anatol, Medal and also distribute in France all the songs by The Beach Boys. In the States, Warner Bros. will distribute Petula Clark records, and

Kapp will release an LP by Françoise Hardy singing in French.

NOVEMBER

Among the new records of the month we have Richard Anthony, Sylvie Vartan, Claude François, Leny Escudero. Claude François, has recorded a French treatment of an American top hit by The Newveats; "Bread and Butter," the French title is "Du Pain Et Du Beurre." Brenda Lee has been a huge success, and especially after a show at the Olympia Music Hall. On the same program we saw Frank Alaimo. For Nana Mouskouri, she obtained a great success during her performance in the U.S.A. "Tobacco Road" has been recorded by Dick Rivers while "Pon Gentille," an adaptation of "Bad Boy" has been recorded by Françoise Hardy. The popular Belgium singer Salvatore Adamo just received a gold record with 19 diamonds on his great success in Belgium and France for his song "Vous Permettez Monsieur." On Polydor Records we have a new "Compagnons de la Chansons" record with three songs by Charles Aznavour; "Y'a Rien A Faire," "Au Printemps Tu Reviendras" and "Que C'est Triste Venise." Gigliola Cinquetti, Italian winner of the Grand Prix De l'Eurovision-1964, recorded her first French record with "Tout Un Diamanche Loin De Toi." The new dance called Letkiss is coming from Lapony, but has been created in France by Myeriam Michelson. We have heard a Barclay record played by an orchestra directed by Anton Letkiss. Jacques Brel obtained an enormous success by his performance at the Olympia Music Hall. His new song "Amsterdam" is currently a best seller. Gilbert Becaud is just back from Canada where he sang 14 times in Montreal and Quebec. Les Surfs, the six Madagascan

singers, are very pleased with their first trip to the U.S.A. They recorded 12 English songs in New York, and performed twice in Hollywood. "Un Ete" and "Adrien La Bell" by Alain Barriere will be treated in Italian. Petula Clark, a Vogue star, released a single in English with "Downtown," and another one in German with a treatment of the French song "Ce Soir Tu T'en Vas." Vogue's manager is also very glad about the good reception of the last Michel Paje EP with "Partout Ou Tu T'en Vas." A very interesting song pull was organized last month. The best one in the Charm category was Bobby Solo with "Une Lacrima Sul Viso." Soviet Army Choir with "Kalinka" was the first on the Folks-list. The domain rhythm was taken by Johnny Hallyday with "Le Peintencier." Further on we have Charles Aznavour with "Que C'est Triste Venise," who was the best author-composer. And last the best one in the group of instrumentalists was The Shadows with "Shadoogie." For this month France's Best Seller has been "Que C'est Triste Venise" by Charles Aznavour.

DECEMBER

"L'Academie du Disque Francais" has arranged a prize-list for 1964. In Prix Francis Carco the best male singer was Jacques Brel. The best female singer was Juliette Greco and the best song of the year was "T'es Vemi De Loin" written by Louis Amade and Gilbert Becaud. The best dance record seemed to be "Surprise Partie Twenty," an LP including Petula Clark and Françoise Hardy. The Prix Arthur Honnegor was given to Louis Armstrong while the Prix Colette was given to Simone Signoret. This month there has been a one-man show by Gilbert Becaud at the Olympia Music Hall, and also a one-night

(Continued on page 53)

LOOKING FOR FRENCH HITS FESTIVAL'S GOT THEM



MARIE

1 **LAFORET**

GIGLIOLA

2 **CINQUETTI**

3 **LES SURFS**

BOBBY

4 **SOLO**

ANDRE

5 **VERCHUREN**

PIA COLOMBO

NINA

& **FREDERIK**

MICHEL

DELPECH



LOOKING FOR PROMOTION FOR YOUR HITS FESTIVAL'S GOT IT

ALL OVER THE WORLD LIFE IS BETTER WITH

disques
vogue



ALL OVER THE WORLD

disques
vogue



JEAN-JACQUES DEBOUT



MICHEL PAJÉ



JEAN-CLAUDE DARNAL



PIERRE PERRET



JEAN CONSTANTIN



SIDNEY BECHET

A WORLD OF MUSIC FOR YOU

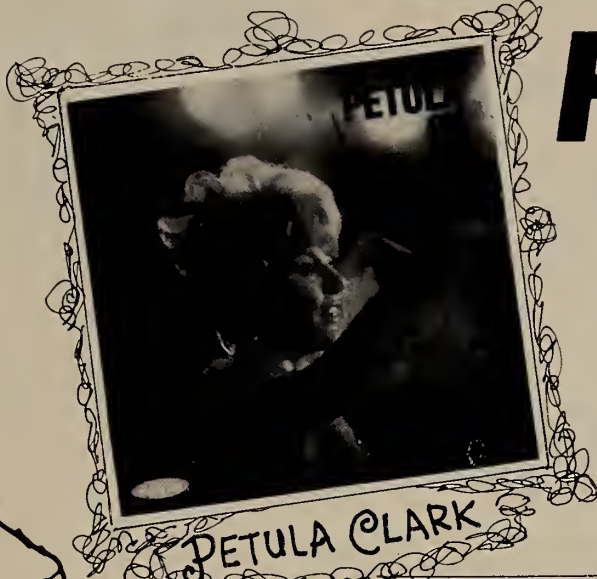



**disques
vogue**

VOGUE P.I.P.
PARIS — VILLETANEUSE
(Seine) — FRANCE
TEL : 752.73.00
Telex: VOGDISC 28.493

DISTRIBUTE :



BRANCHES

VOGUE BELGIUM
VOGUE P.I.P. BELGIQUE
VOGUE S.A.
35 Bld Barthélémy
BRUXELLES (Belgium)

VOGUE GERMANY
DEUTSCHE VOGUE
SCHALLPLATTEN
VOGUE SCHALLPLATTEN
GMBH
ZUR MUHLE 2
5021 Grosskonigsdorf bei
Koln (Germany)

VOGUE SWITZERLAND
VOGUE S.A.
70 avenue des Alpes
MONTREUX (Switzerland)

DISTRIBUTED THROUGHOUT THE WORLD



EXCLUSIVE DISTRIBUTORS FOR

DURIUM (Italy)	ORFEON (Mexico)	ROULETTE (U.S.A.)
ELEKTRA (U.S.A.)	DUKE-PEACOCK (U.S.A.)	SCEPTER (U.S.A.)
G.N.P. (U.S.A.)	PYE (Great Britain)	WAND (U.S.A.)
GURTLER JOLLY MUSIC (Italy)	REPRISE (U.S.A.)	RED BIRD (U.S.A.)
LAURIE (U.S.A.)	WARNER BROS. (U.S.A.)	JUBILEE (U.S.A.)
MILLER INTERNATIONAL (U.S.A.)	KAPP (U.S.A.)	CLAN (Italy)
MOCAMBO (Brazil)	DOT (U.S.A.)	KENWOOD (U.S.A.)
PREMIER (U.S.A.)	GLAD HAMP (U.S.A.)	

AND MANY OTHER COMPANIES

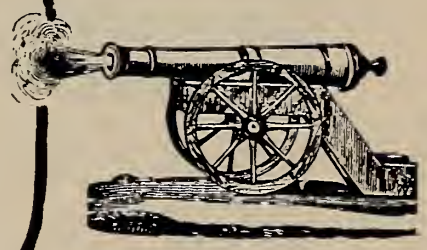

ASSOCIATED PUBLISHING COMPANIES

VOGUE INTERNATIONAL
82 rue Maurice Grandcoing
VILLETANEUSE (Seine)
FRANCE
TEL: 752.73.00

EDITIONS DU CARROUSEL
54 rue d'Hauteville
PARIS (Seine)
FRANCE
TEL: 824.93.82
et 770.81.38

EDITIONS ALPHA
54 rue d'Hauteville
PARIS (Seine) FRANCE
TEL: 824.93.83

EDITIONS GERARD CALVI
54 rue d'Hauteville
PARIS (Seine)
FRANCE
TEL: 824.93.83

**VOGUE INTERNATIONAL
BELGIQUE**
35 Boulevard Barthélémy
BRUXELLES
BELGIUM

EDITIONS BELMONT
70 avenue des Alpes
MONTREUX SWITZERLAND

EDITIONS BELMONT
ZUR MUHLE 2
5021 Grosskonigsdorf bei
Koln GERMANY



NEW YORK OFFICE C/O JOSEPH E. ZERGA
MILL LANE, WINDMILL FARM, ROUTE 2,
ARMONK, NEW YORK, U.S.A.

FRANCE – The Past Twelve Months

(Continued from page 48)

stand of the Beach Boys. For the first time as leading man, the French singer and composer Alain Barriere performed at the Olympia Music Hall. Last summer he reached Top of the Charts with his song "Ma Vie." The four new songs which he presented at the Olympia are: "Les Sabots," "L'Aoeugle Du Pont Au Change," "Mais Je Vous Dis" and "Attends." Hugnes Aufray was co-starring in that program. In the same show we also saw Jean Yanou. New recordings have been made by the French female group Les Gam's with "Rien N'est Trop Beau" and another one "Oui C'est Tci" by Frank Fernandel. A 13-LP set has been released with all songs recorded by Charles Trenet. Young French author Pierre Barouh has written French lyrics to J. Van Wetter's melody, "La Playa." It has been recorded by a new French female singer star Marie Laforet. Leon Cabat, President of Vogue Records, is delighted with the success of his young star's latest records: Michel Paje's "Partout Ou Tu T'en Vas," Danyel Gerard's "Il Pleut Dans Ma Maison" and "Ou S'en Balance," Guy Mardel's "Si Tu N'y Crois Pas," Jean Jacques Debout's "Previens Les Auris, Previens Les Copains." The popular Madagascan sextet, Les Surfs, has just recorded "Tu Pars Et Tu Pleures." Concerning Guy Mardel, he has got a really good start as singer and composer, and his songs are already requested by several countries. Mort Shuman, American composer, has newly written some songs intended for some French artists. Thus, Eddy Mitchell recorded "Le Generique" and "Johnny Merci," Monty "Oh Oui!" Olivier Despax "Qu'En Pensez Vous" and France Arnell "On Les Voit." A lot of English singers are on stage in Paris for live broadcasts, including the Honeycombs, the Kinks, Sandie Shaw and the Animals. During this month "Que C'est Truste

Venise" by Charles Aznavour has been the best-seller in France.

JANUARY

The discovery of the film "My Fair Lady" has been a great success. At the same time the different records released by CBS with the songs of the film are really hitting. A kind of a civil action opposing Charles Trenet and Claude Francois has taken place. The problem was caused by a certain song, but they are now good friends. As the star of a show Muscorama, the Belgium singer Salvatore Adamo had an enormous success. Some of his songs are already very popular in France; "Tombe La Neigi," "Quand Les Roses" and "Vous Permettez Monsieur." An international work made by Vogue Records during 1964 was that a lot of foreign artists, whose records are distributed in France by Vogue, came to France including Trini Lopez, Dionne Warwick, The Honeycombs, The Kinks, Sandie Shaw and Udo Jurgens. Petula Clark, whose "Downtown" recording reaches the top of CB's American chart, has been on a tour in Canada. Before representing France at the Italian San Remo Festival, she spent a few days in the U.S.A. Michel Paje has been to Germany where he was featured with Françoise Hardy on a TV show. Johnny Hollyday just came to France to record a new EP with a French adaptation of "She is a Woman" ("Ou a ses jours"). Sheila will also record a new EP with a French treatment of The Beatles No. 1. "I Feel Fine." Orchestra conductor Eddie Vartan is now recording on Philips. Frank Alamo has released "Le Chef de la Bande" which is a French treatment of "Leader Of The Pack." Since the beginning of 1965 we have two new dances in France; one is called the "Tac-O-Tac" presented by Albert Raisner, and the second one is "La Bostella."

FEBRUARY

A new record company has been established in France called Mondio-phonie. It is founded by associated artists which are all from the Opera de Paris. The President is Henri Giovannetti. The performance by Charles Aznavour at the Olympia Music Hall has really been a great success. His new songs are excellent and might well become hits. They are: "Le Toreador," "C'est Fini" and "Je Te Rechaufferai." Everybody in Paris knows what "La Bostella" is. This dance has been invented by a French journalist Honore Bostel and seems to be off to a flying start. The first Bostella record presents the two original titles "Dansons La Bostella" and "Viens Danser La Bostella." The music of the first one has been written by Sacha Distel. In France, we have had the pleasure of seeing Duke Ellington with his band. He spent five days in France during his very extensive continental tour. Talking of jazz, Billy Taylor was delighted by the success in Paris of his "My Fair Lady" version. In another kind of jazz, there has been released a second LP of the Village Stompers with "Dominique" and "Don't Think Twice It's All Right." France has also launched a new Dixieland group; Les Haricots Rouges. The well known deejay, Michel Cogoni is getting on very well. On his last EP, he sings a French adaptation of "Amore Scusami:" "Armour Exeuse Moi." France Gall is actually No. 2 on the French charts with her recording of "Sacre Charlemagne." Johnny Hallyday has recorded a new EP called "Johnny Lui Dit Adieu" and "Ou Te Montrera Du Doight." Vogue has released Dionne Warwick's first EP with a song in French called "Un Toit Ne Suffit Pas." For Henri Salvador, he has recorded "La Grosse Bete," a French treatment of "La La." Petula Clark is more and more an international star. In France we have three recent

records of her. One in English is "Downtown," number one on the U. S. charts. After the success of this record she has been engaged for two weeks as the lead at the Olympia Music Hall in Paris. Another record is in French, "Dans Le Temp," a French treatment of "Downtown," one in Italian is "Invece No" which reached the San Remo finals. The winner of the San Remo Festival was Bobby Solo's "Se Piangi, Se Ridi." Disks by Sandy Shaw and Françoise Hardy have now been recorded in English. There has also been released a new single by Sacha Distel with "Petit Oiseau Bleu" and "Je Danse Avec Toi." An interesting movie soundtrack is an EP containing music from Ives Robot's film "Les Copains" with one song by Georges Brassens tagged "Les Copains d'Abord." During the San Remo Song Festival MGM was represented by Connie Francis and Johnny Tillotson. The songs performed by these artists have been released as EP's in France and as singles in other European countries. A thing which is really remarkable is that Adamo's "Vous Permettez Monsieur" has been No. 1 on French EP Top Ten during the whole month of February.

MARCH

Sylvie Vartan has left France for a very extensive tour around the world. For the moment she is in Turkey. The new James Bond story "Goldfinger" has now been presented in Paris. There are already eight recordings of the main theme, including one by Shirley Bassey, Philippe Adler and Michel Nettor has made a conclusion from letter received to their "Hit Parade du Jazz"; that the most popular jazzmen in France are: Charlie Parkor, Martial Solal, Omar Peterson, Louis Armstrong and Bersie Smith. Speaking of jazz, we had the pleasure to see the Art Blakey Jazz

(Continued on page 54)

GROUPE DES EDITIONS MUSICALES TUTTI

46, RUE LAFFITTE. PARIS 9

Editions Louise

"MA VIE"

written and recorded by:

ALAIN BARRIERE

"ATTENDS"

Editions Tulsa

"LES BRAS EN CROIX"

recorded by:

JOHNNY HALLYDAY

"MOODY RIVER" (MOUDITE RIVIERE)

Editions 57

"LES COPAINS D'ABORD"

written and recorded by:

GEORGES BRASSENS

"LA GUERRE DE 14-18"

Editions Tutti

"ELLE ETAIT SI JOLIE"

(Eurovision 1963)

ALAIN BARRIERE

"N'AVOUE JAMAIS"

(Eurovision 1965)

GUY MARDEL

FRANCE - The Past Twelve Months

(Continued from page 53)

Messengers and Jimmy Guiffree in Paris for two concerts at the Olympia Music Hall. There has newly been released a very interesting 10-LP set named "Plaisir du Jazz" in an effort to popularize jazz in France. Each LP is dedicated to a well known musician. We have for example Cannonball Adderly, Erroll Garner, Coleman Hawkins. The French composer Maurice Fanon's second LP, "La Petite Juive," has just come out and is already well launched. Joe Dassin, film producer Jules Dassin's 26-year old son, has just made his first EP for CBS. The artist sings American folk songs in French and is making a good start as a movie actor. A big event has been the proclamation of the prize-list of "Grand Prix International du Disque 1965 de L'Academie Charles Cros" which is one of the most important yearly prizes. Some of the results are as follows: The Best French Singer: Hughes Auffray. 1965 Revelation: Jean Claude Aunoux. Foreign Singers: Pete Seegar and Ismael. Light Music: A Sydney Bechet composition played by Gerard Calvi's orchestra. Theater: "Le Tartuffe Ou L'Imposteur" written by Moliere. Humour: Raymond Devos. Jazz: Wes Montgomery. Jazz Re-issue: Charlie Christian with Benny Goodman's Sextet and Orchestra; "Back to Back" by Duke Ellington and Johnny Hodges. Among other events of the month is the release of a Chuck Berry LP recorded in Paris during his performance at the Olympia Music Hall. Alvin Barriere is back from Hambourg where he featured in an important TV show. His song, "Ma Vie" is a success all around the world. During the month of February we remarked that Adamo's "Vous Permettez Monsieur" was No. 1. This song has kept its place during the first part of March, but at the end of the month "Le Toreador" by Charles Aznavour became No. 1 at the French EP Top Ten.

APRIL

The Eurovision song contest is over and France Gall, who represented Tele Luxembourg has won. She has recorded the winner tune "Poupee de Cire Poupee de Son" in English, Italian and German. It brought her an enormous success. Guy Mardel, 21 years old, author and composer, took third place at Naples for France, behind England's Kathy Kirby who was second. Mardel composed his own tune "N'Avone Jamais" for the contest. This song is making a very important international start. In France we can already find several recordings of Eurovision songs. The French one of course by Guy Mardel, Luxembourg's entry by France Gall, the song of Monaco by Marjorie Noel, the United Kingdom's tune by Kathy Kirby, Spain's entry by Conchita Bautista, the song from Austria by Udo Jurgens and the Italian contender by Bobby Solo. A very good work has lately been done by publishers and record firms in France. "J'Avais Deux Amis" has been recorded by Eddy Mitchell and "Terry," a real success in Great Britain by Claude Francois. There are now two very good versions in French of the Italian song from the Sanremo Festival "Le Colline Sono Tu Fiore," called in French "Le Printemps Sur La Colline." One is done by Dalida and the other one by Les Surfs. Charles Aznavour has left the Olympia stage and the new lead is Petula Clark. One day on that same stage we also had the pleasure to see Roy Orbison. Still for Charles Aznavour is that his record "Le Monde Est Sous Nos Pas" from the film "Week End A Zuydcoote" will be sub-published in several countries including Japan. Through Pathe label, Dick Rivers released a new 45 RPM with a French adaptation of "Go Now," the Moody Blues' hit. The French title is "Va T'En, Va T'En," and on the same record we have "Et Quand L'Amour S'En Va." There is also a new record from

Gilbert Becaud, "La Voix de Son Mouret," "La Vie D'Garcon" and "Il Faut Marcher." Les Lionceaux just recorded their fifth EP. These four boys are now the most popular French Rock'n Roll group. Some of their new titles are: "Le Vrai Google Eye" and "Dis Moi Pourquoi." The result this year of finding the most popular artists in France is as follows: The most popular male singer is Jacques Brel and the most popular female singer is Petula Clark. The first week of this month "Alors Salut Yeh Yeh" by Claude Francois was No. 1 on the French EP Top Ten, but during the second week it was replaced by Richard Anthony's "Je Me Suis Souvent Dernande." For the rest of the month "Poupee de Cire Poupee de Son" by France Gall has kept its place as No. 1.

MAY

After an English tour, the Tamla-Motown show stopped for a night at the Olympia Music Hall in Paris. On the stage we had the pleasure to see The Supremes, Martha and the Vandellas, Earl Van Dyke Sextet and Stevie Wonder. New information is that Dean Martin's last hit "Send Me The Pillow You Dream On" has just been recorded by Les Surfs. "Non Son Degno Di Te," which has been No. 1 in Italy, has been recorded in France by Dalida entitled "Tu N'as Pas Merite." The Rolling Stones came to Paris for three days to sing at the Olympia Hall. But in France the biggest event in show business this month was Johnny Hollyday's and Sylvie Vartan's marriage. Concerning Johnny Hollyday, he has recorded a song with French title "Mes Yeux Sont Fous," and he has released a new EP with "Quand Reviens La Nuit," a French treatment of "Mr. Lonely." For Sylvie Vartan she has recorded three songs on her new EP "C'est A Deux Pas," "Pour Ne Pas Pleurer" and "Cette Lettre La." Pe-

tula Clark has just finished a two-week performance at the Olympia Hall in Paris. It was a really great success. New Olympia lead is Enrico Macias, and in the same program we see the Italian lark Gigliola Cinquetti and Les Surfs. The popular artist Bob Dylan has released his first LP in France. Adaptations of his songs have been recorded by Hugues Auffray and Richard Anthony. A great success was obtained by The Kinks at their one night stand at Palais de la Mutualite. The Everly Brothers have also been in Paris to feature in several TV programs. There is an excellent LP from Lucky Blondo where we notice French adaptations of "Una Lacrima Sul Viso," "Red Roses For A Blue Lady" and "Lonely Boy." Nancy Holloway has released an EP in English with the song from the film "The Gentleman from Cocody." A new record from Sacha Distel, which contains "Petit Oiseau Bleu" is already making a good start. Alain Barriere is writing a movie score for "Pas de Panique" in which he is starring. And Frank Alamo has been released "Ma Vie a T'attendre" and "Des Filles et Des Garcons." An important one-day visit at the Olympia has been Johnny Mathis. The Italian artist, Bobby Solo has been in Paris to star in a TV program. There is now a very good start of the new dance "Sirtaky" with music from the film "Zorba le Grec." Movie star Eddie Constantine just recorded a new EP with a French treatment of Cole Porter's "I've Got You Under My Skin." Taking a look at the French EP Top Ten, "Poupee de Cire Poupee de Son" by France Gall was No. 1 during the first week this month. But it was replaced by Guy Mardel's "N'Avone Jamais" which kept the first place during two weeks. For the rest of the month "La Nuit" by Adamo kept the place as No. 1

(Continued on page 69)

GÉRARD TOURNIER

GROUP OF COMPANIES

AGENCE MUSICALE INTERNATIONALE

EDITIONS MUSICALES PHILIPPE-GERARD

EDITIONS DERBY

EDITIONS FRANCOBEL

and

foreign affiliates

NOW

FULLY INDEPENDENT

and

MORE THAN EVER

AT YOUR SERVICE.

New address: 67, RUE DE PROVENCE
PARIS 9'

Telephone: 874-19-41 and 874-26-36

N°1 FRENCH POP CATALOGUE



**THE
STARS
ARE
ON
BARCLAY**



CHARLES AZNAVOUR ★
JACQUES BREL ★★ ★★
DALIDA ★★ ★★ ★★ ★★
JEAN FERRAT ★★ ★★
LEO FERRE ★★ ★★ ★★
EDDY MITCHELL ★★ ★
HUGUES AUFRAY ★★ ★
MONTY ★★ ★★ ★★ ★★
CHARLES TRENET ★★
DARIO MORENO ★★ ★
ANDRE DASSARY ★★

IN FRANCE

COMPAGNIE PHONOGRAPHIQUE FRANCAISE
143, AVENUE DE NEUILLY - NEUILLY S/SEINE

IN BELGIUM

COMPAGNIE PHONOGRAPHIQUE FRANCO BELGE
BARCLAY 31, RUE DU LOMBARD - BRUXELLES

IN HOLLAND

BARCLAY NEDERLAND SINGEL 104 AMSTERDAM

DISTRIBUTION :



PLAY BACH

Disque n°1 mono 153.905 stéréo SSL 40.500
 Disque n°2 mono 153.918 stéréo SSL 40.502
 Disque n°3 mono 154.003 stéréo SSL 40.507
 Disque n°4 mono 154.046 stéréo SSL 40.516

JACQUES LOUSSIER

CHRISTIAN GARROS et PIERRE MICHELOT



DECCA
Disques

EN FRANCE

les vedettes d'aujourd'hui

SYLVIE VARTAN

CETTE LETTRE LA - C'EST A DEUX PAS - JE LE VOIS - POUR NE PAS PLEURER - 86.096
 DANS TES BRAS - 86.084
 SHA LA LA - 86.060
 LA PLUS BELLE POUR ALLER DANSER - 86.046

ALAIN BARRIERE

LES SABOTS - ATTENDS - MAIS JE VOUS DIS - L'AVEUGLE DU PONT-AU-CHANGE - 86.077
 MA VIE - 86.053
 LA MARIE JOCONDE 86.023
 ELLE ÉTAIT SI JOLIE - 86.618

les vedettes de demain

CHANTAL GOYA

UNE ÉCHARPE, UNE ROSE - COMMENT LE REVOIR - LA PLUIE DU CIEL - SOIS GENTIL - 86.095
 C'EST BIEN BERNARD - 86.074

NOEL DESCHAMPS

JE N'AI A T'OFFRIR QUE MON AMOUR - AUJOURD'HUI TOUT VA VITE - PASSE, PASSE TON CHEMIN - A QUOI ÇA TIENT - 86.094
 TE VOILA - 86.075
 CE N'EST JAMAIS ASSEZ - 86.062

RCA VICTOR



FRANCE RECORD MANUFACTURERS

ASTORIA
 83, Rue du Chateau des Rentiers
 Paris 13e
 POR. SO. 51

A2 DISC
 26, Rue Francois jer
 Paris 8e
 225.65.00

B.A.M.
 123, Brd Raspail
 Paris
 LIT. 16.12

BARCLAY
 143, Avenue de Neuilly
 Neuilly/Seine
 SAB 60.30

BEL AIR
 18 Rue de Douai
 Paris 9e
 FIG. 30.90

CANETTI JACQUES
 252 FBG St. Honore
 Paris 8e
 WAG. 69.70

C.B.S.
 92, Rue de Paradis
 Paris 10e
 PRO. 30.47

CHANT DU MONDE
 32, Rue Beaujon
 Paris 8e
 WAG 67.33

DECCA
 30, Rue Beaujon
 Paris 8e
 WAG. 19.01

ERATO
 60, Rue de la Chaussee d'Antin
 Paris 8e
 TRI 78.71

FESTIVAL
 3, Rue de Gramont
 Paris 2e
 RIC 96.10

JOKER
 17, Rue St. Florentin
 Paris 8e
 742. 88. 99

LUMEN
 3 Rue Garanciere
 Paris 6e
 MED. 29.30

PACIFIC
 20 bis, Rue Louis Philippe
 Nuilly/Seine
 MAI. 96.24

PATHE MARCONI
 19, Rue Lord Byron
 Paris 8e
 BAL. 53.00

PHILIPS
 53, Avenue Franklin Roosevelt
 Paris 8e
 BAL. 70.40

POLYDOR
 3, Rue C vallotti
 Paris 8e
 LAB. 05.39

PRESIDENT
 30, Rue Pierre Semard
 Paris
 TRU. 69.56

PRETORIA, STUDIOS DES VICTOIRES
 50, Rue Croix des Petits Champs
 Paris jer
 GUT. 45.16

R.C.A.
 28 Rue Beaujon
 Paris 8e
 WAG. 19.01

RIGOLO
 6, Place Vendome
 OPR. 87.05

RIVIERA
 5, Rue Geoffroy-Marie
 Paris 9e
 82U. 71.66

TEPPAZ
 160, Rue Lafayette
 Paris 10e
 BOT. 65.30

TYPIC
 13, Rue de l'Echiquier
 Paris
 PRO. 39.15

UNI DISC
 31 Rue de Fleurus
 Paris 6e
 LIT. 46.02

VEGA
 49, Avenue Hoche
 Paris 8e
 CAR. 16.34

VERSAILLES
 14 Avenue Hoche
 Paris 8e
 WAG. 81.93

VOGUE
 82, Rue Maurice Grancoing Villetaneuve
 PLA. 73.00

WINDSOR
 78 Rue Raymouard
 Paris
 MIR. 26.20

FRANCE MUSIC PUBLISHERS

ALLELUIA
 252, Rue du fbg St Honoré Paris

ALPHA
 54, Rue d'Hauteville Paris X° TAI 93-82

AMOUR
 24, Rue Pierre Semard Paris IX° TRU 56-39

AZNAVOUR CHARLES
 124, Rue de la Boetie Paris VIII° BAL 80-30

ASSOCIEES
 89, Rue de la Boetie Paris VIII° ELY 76-54

BAGATELLE
 10, Rue Washington Paris ALM 17-99

BARCLAY
 2 Avenue de Messine Paris VIII° LAB 06-03

BEUSCHER
 25 Brd Beaumarchais Paris TUR 18-98

CALIFORNIA
 2 Avenue de Messine Paris VIII° LAB 06-03

CARAVELLE
 153 Avenue de Neuilly Neuilly/Seine MAI 33-37

CARROUSSEL
 54, Rue d'Hauteville Paris X° TAI 93-82

CHAMPS ELYSEES
 5 Avenue de l'Opera Paris I° OPE 37-37

CHAPPELL
 4, Rue d'Argenson Paris ANJ 56-05

CONCORDE
 5, Rue Lincoln Paris VIII° ELY 06-22

CONTINENTALE
 17, Rue Monsigny Paris 2° RIC 61-83

D.M.F.
 14, Avenue Hoche Paris VIII° WAG 81-93

ECO
 19, Rue Lord Byron Paris VIII° BAL 53-00

FELDMAN
 5, Avenue de l'Opera Paris I° OPE 37-37

FRANCE MELODIE
 5, Avenue de l'Opera Paris I° OPE 37-37

FRANCIS DAY
 5, Avenue de l'Opera Paris I° OPE 37-37

FRENCH MUSIC
 124, Rue de la Boetie Paris 8° BAL 80-30

GARZON
 13, Rue de l'Echiquier Paris X° PRO 39-15

GOLF
 8, Rue Jules Potin Neuilly/Seine MER 14-40

IMPERIA
 14, Avenue Hoche Paris VIII° WAG 81-93

LEGRAND
 252, Fbg St Honoré Paris MAI 50-16

LEMARQUE FRANCIS
 121, Brd de la Marne La Varenne St Hilaire
 GRA 34-21

LOUIS GASTE
 5, Rue du Bois de Boulogne Paris XVI°
 POI 53-53

MANHATTAN MUSIC
 2, Avenue de Messine Paris VIII° LAB O 06-03

MERIDIAN
 5, Rue Lincoln Paris ELY 06-22

MERRY MUSIC
 89, Rue de la Boetie Paris VIII° ELY 76-54

METROPOLITAINES
 3, Rue Chaptal Paris IX° FIG 24-03

PATHE MARCONI
 1, Rue Laffitte Paris IX° TAI 44-29

PEPE LUIZ
 14, Rue Chaptal Paris IX° FIG 24-03

PETER MAURICE
 14, Avenue Hoche Paris VIII° WAG 81-93

PLANTE JACQUES
 35, Brd Malherbes Paris ANJ 08-93

PIGALLE
 89, Rue de la Boetie Paris 8° ELY 76-54

PRESENCE
 33, Rue du Fbg St Martin Paris NOR 89-05

PROGRESSIVE
 89, Rue de la Boetie Paris VIII° ELY 76-54

PROSADIS
 14, Avenue Hoche Paris VIII° WAG 81-93

SALABERT
 22, Rue Chauchat Paris TAI 55-60

SALVADOR
 6, Place Vendome Paris OPE 87-05

SALVET ROBERT
 89, Rue de la Boetie Paris VIII° ELY 76-54

SALVET PIGALLE
 89, Rue de la Boetie Paris VIII° ELY 76-54

SEMI
 5, Rue Lincoln Paris ELY 06-22

TROPICALES
 28, Brd Poissonniere Paris PRO 25-28

TUTTI
 46, Rue Laffitte Paris IX° LAM 40-42

UNIVERSELLES ANDORRA
 52, Fbg St Martin Paris X° NOR 45-91

VDOME
 5, Rue Lincoln Paris ELY 10-81

VENTURA RAYMOND
 14, Avenue Hoche Paris VIII° WAG 81-93

VOGUE INTERNATIONAL
 84, Rue Maurice Grandroing Villetaneuve Seine
 PLA 73-00

THE GREATEST RECORDING ORGANIZATION IN THE FAR EAST



38 YEARS OF HISTORY IN THE INDUSTRY

VICTOR COMPANY OF JAPAN, LTD.

MAIN OFFICE 4-1 NIHONBASHI-HONCHO CHUO-KU TOKYO
RECORD DIVISION 13-2 TSUKIJI CHUO-KU TOKYO



ROMI YAMADA SINGS FOR WORLD

JAPAN

煙草のけむり

SV-119, SS-1545
VICTOR CO., OF JAPAN

U.S.A

ARIGATO (Thank You)

47-8481
RCA VICTOR

ITALY

NON AVERE
PIU' PAURA

45 N 1409
RCA ITALIANA



**THE
BIGGEST
PUBLISHER
IN JAPAN**

日音

Nippon

PRESIDENT: SHIGERU AKIMOTO

- AFFILIATE OF **TBS** (TOKYO BROADCASTING SYSTEM)
- GOOD REPRESENTATION OF FOREIGN SONGS
- GREAT SUCCESS IN THE ORIGINAL JAPANESE SONGS
- MUSICAL BOOKS PUBLICATION

Address: No. 2, 1-Chome, Ginza-Nishi, Chuo-ku, Tokyo

Phone: (535)5851-9

Cable: PUBLISHMUSIC TOKYO

JAPAN — The Past Twelve Months

Looking back to the musical situation in Japan the past six months, I can't but feel a little surprised at recognition of a great many performances by foreign artists, most of which have turned out to be a great success.

Everytime they come to Japan, record companies never fail to release the anniversary discs which have also shown good sales. Nothing would be more delightful to real music lovers than to be able to enjoy all kinds of music performances by artists of all nations, while this fact seems to be featuring Japanese nationality "likely to be impassioned and to be cool".

Anyway, Japan is the best place for music entertainment.

Relating to foreign artists having come here from January on, during new year season, Art Blakey and his jazz messengers, The Ventures And The Astronauts, Pat Boone, and big four drummers, Philly Joe Jones, Buddy Rich, Louis Bellson and Charles Persip, enlivened pop and jazz fan. Among them, performances by Art Blakey and by big four drummers were reportedly said to have been successful.

The Ventures are expected to pay their re-visit here in July. "Astronauts In Japan" was released by Nippon Victor to honor their visit.

The tendency of Japanese young music lovers in recent pop music is strong-beated by use of electric guitars, which is seemingly due to The Ventures and The Astronauts's performances.

In the end of January, Alfred Hause and his world famous tango Orch. opened its Japan concert series at Yokohama to add a new page to the annals of tango music in Japan, especially because Japan's tango lovers had their taste of authentic European tango last year with the visit here of Arthur Malando and his tango Orch. from Holland. The new release "All About Continental

Tango" was made by Japan Victor on Philips label which had been put on upper ranking in the chart for months.

In the beginning of March, Chan-son lark Juliette Greco paid her second visit to Japan after the interval of five years, for a series of four performances where she received a storm of applause. She was in the invitation of Toho Geino Production.

In the end of March, in the invitation of Kyodo Kikaku, New Glenn Miller Orch. revisited here to have had sixteen performances. Their records are released by Nippon Victor. In the same month, The Four Freshmen arrived here for 18 day performance tour.

In May, two of Liverpool Sounds Group, Peter and Gordon, and The Animals had a performance tour in and around Tokyo which was reportedly said to have been successful.

Sylvie Vartan also had her successful performances in May. With the help of performances, her popularity has gone up much more as shown in the good sales of her records and in the good result of her film performances.

Odetta's first performance in Japan was made in Tokyo on May 8 gathering. From her wide repertories; Negro Spiritual, folk song, and labours song, she introduced "If I Had A Hammer", "Fox", "Water Boy", and so on. Nippon Victor newly released "Odetta Sings Of Many Things" in honor of her visit here.

In Mid-May, best prize winner in past San Remo Music Festival, Canzone singer, Luciano Tajoli (1961) and lark Gigliola Cinquetti (1964) were invited by Kambara Music Office. With the help of getting a place in the festival, by Japanese participants, Yukari Ito, many of Canzone fans gathered at the concert

In June, much awaited pop lark, Brenda Lee arrived here in Japan for the ten days performance at the invitation of Shinnichi Kogyo Co.

The Most Progressive Record Company In Japan.



TEICHIKU RECORDS Co., Ltd.

TODAY'S BEST SELLERS!

YOGIRI NO BLUES

DECCA Exclusive Artist
Sam Taylor Plays
Japanese Hit Tunes

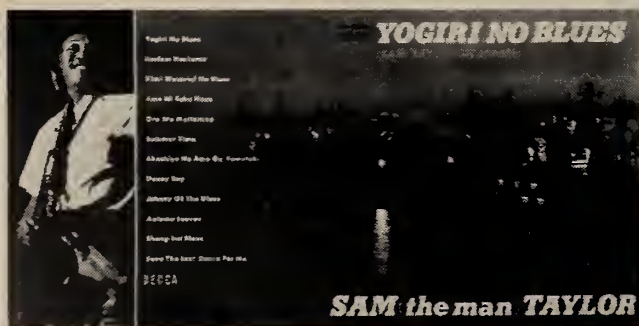

SAM the man TAYLOR



THE BEST OF YUJIRO ISHIHARA

Top Singer and
Movie Actor in Japan



WE REPRESENT IN JAPAN

**HIGHEST CHOICE OF EXCITING
LABELS THROUGHOUT WORLD**

**CBS
EPIC
AUDIO FIDELITY
UNITED ARTISTS
PYE
TIME
DISNEYLAND
VEE-JAY
MAINSTREAM
STEREO FIDELITY
MAHALO
MUSICA ET LITERA
ERATO
PALETTE
HISPA VOX
AMADEO
EURODISC
SUPRAPHONE
HULA
FESTIVAL
ITALDISC
TURICAPHON**

NIPPON COLUMBIA Co., Ltd.
17 Akasaka Tango-cho, Minato-ku
Tokyo Japan

LATEST HITS

(Japanese Popular Songs)

“KIMI DAKE O” (Only you)

“NAMIDA O ARIGATO”

(I am grateful of your tears)

.....more than 500 songs contained
in our Catalogue.



CROWN MUSIC PUBLISHER, INC.

Address: No. 1 Akasaka-tamachi 7-chome,
Minatoku, Tokyo, Japan

FREE

1965 INTERNATIONAL

DIRECTORY

WITH

SUBSCRIPTION

AIR MAIL \$45.00



1780 Broadway

New York 19, N. Y. 10019

JAPANESE BEST SELLING ALBUM



Teruhiko Saigo Crown Records

CROWN

NIPPON CROWN CO., LTD.

No. 1 akasaka-tamachi 7-chome, minatoku, Tokyo, Japan.

GAP

PROMOTER

PRESENTS

SHOWS-ATTRACTIONS-SPORTS

1965-FEW OF THEIR IMPORTATIONS-1965

●SYLVIE VARTAN-May ATTRACTION
(French Importation)

●THE SURFARIS-Aug. ATTRACTION-USA
“Karen” Top hit :

●SAM (the man) TAYLOR-Sep. ATTRACTION-USA

●CARMEN CAVALLARO-Nov. ATTRACTION-USA
(Poet of Piano)

●THE “ORIGINAL” PLATTERS-Dec. ATTRACTION-USA

**SPECIAL
TOKYO PROMOTION
“CONNIE FRANCIS”**

GENERAL ART PRODUCE CO., LTD.

KIYOH BLDG. 1-2 AKASAKA TAMACHI MINATO-KU TOKYO JAPAN

TEL : (583) 8749 CABLE : GENAPROA-TOKYO

PRESIDENT : M. NAGAO VICE-PRESIDENT : T. KASAJIMA

Newest Recording by

Kyu Sakamoto

**MIEKE
and
MARIJKE**

A new song composed in the Netherlands by Hachidai Nakamura and Rokusuke Ei who wrote the big hit

SUKIYAKI

RELEASED IN AUGUST

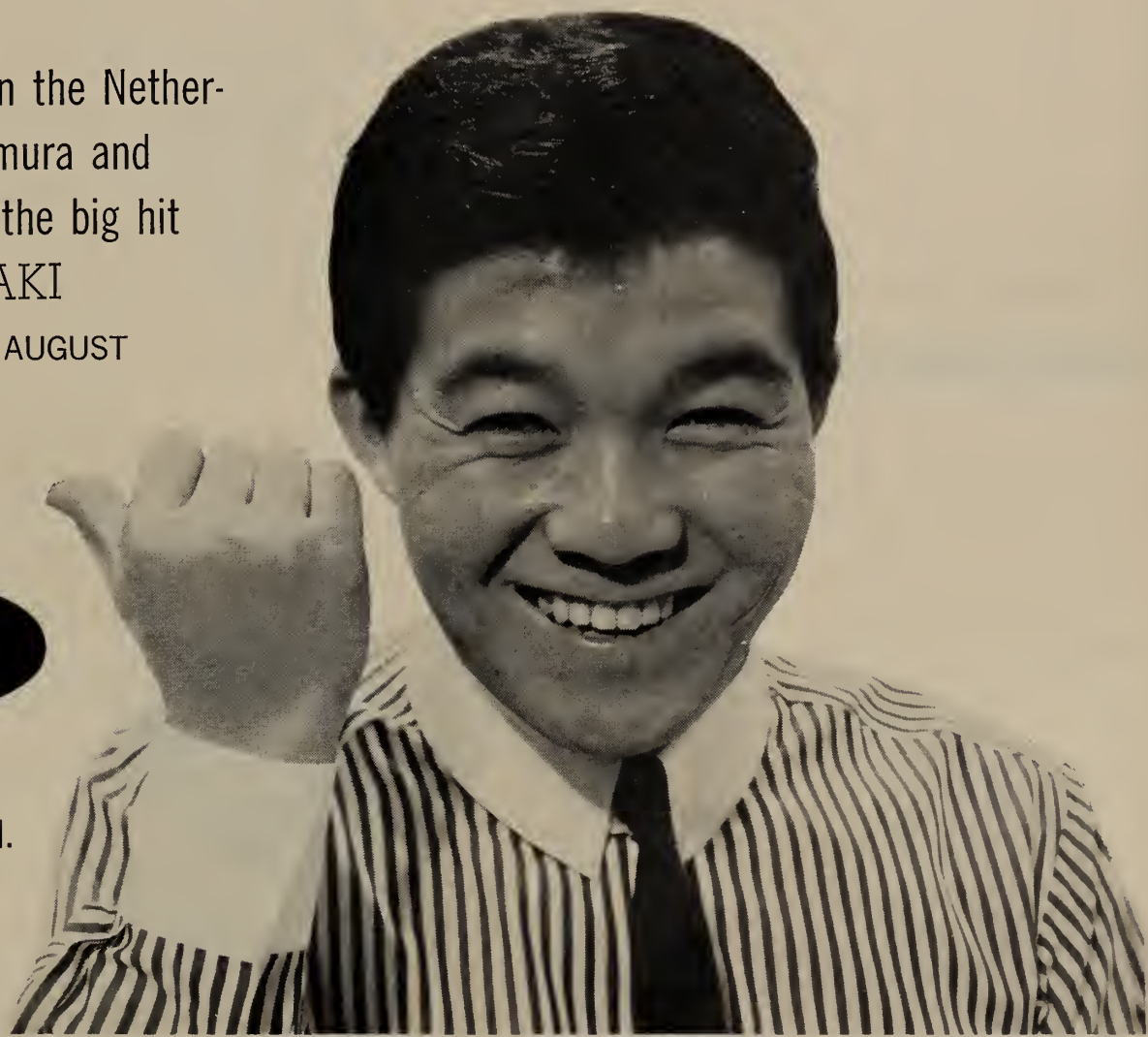

MANUFACTURED BY
Toshiba Musical Industries Ltd.
IN JAPAN

The song "MIEKE and MARIJKE"

published by

TOSHIBA MUSIC PUBLISHING CO., LTD.

President: NORIICHIRO ISHIZAKA

Leading music publisher of Japan!

ADDRESS: 30, TAMEIKE-CHO, AKASAKA, MINATO-KU, TOKYO, JAPAN

CABLE: TOSHIBAPUBLISH TOKYO

JAPAN—RECORD COMPANIES

The Leading Publisher
of
JAPAN

EASTERN MUSIC

PUBLISHING COMPANY LTD.

KYOWA BLDG., 34 SHIBA KOTOHIRA-CHO, MINATO-KU, TOKYO. Cable : EASTMUS

NIPPON COLUMBIA CO., LTD.
Mr. Tokichi Seya
17 Akasaka Tango-cho
Minato-ku, Tokyo

VICTOR COMPANY OF JAPAN LTD.
Mr. Hitoshi Momose
1 Honmachi 4-chome
Nihonbashi, Chuo-ku, Tokyo

KING RECORD CO., LTD.
Mr. Kazumitsu Machijiri
1 Otowa 2-chome
Bunkyo-ku, Tokyo

TEICHIKU RECORDS CO., LTD.
Mr. Toyoji Nanko
148 Kainazuka-cho
Nara City

NIPPON GRAMMOPHONE CO., LTD.
Mr. Shinken Izawa
57 Aoyama Kitamachi 6-chome
Akasaka Minato-ku, Tokyo

TOSHIBA MUSICAL INDUSTRY LTD.
Mr. Genji Kuno
30 Tameike
Akasaka Minato-ku, Tokyo

SHINSEKAI RECORD CO., LTD.
Mr. Kei Hoashi
3 Uchisaiwaicho 3-chome
Chiyoda-ku, Tokyo

NIPPON CROWN CO., LTD.
Mr. Kazuhisa Arita
1 Tamachi 7-chome
Akasaka Minato-ku, Tokyo

1964's BEST 30 in JAPAN

- 1 Diamond Head, Ventures (Liberty)
- 2 Rock And Roll Music, Beatles (Odeon)
- 3 The Slaughter Of The Tenth Avenue, Ventures (Liberty)
- 4 House Of The Rising Sun, Animals (Odeon)
- 5 La Plus Belle Pour Aller Danser, Sylvie Vartan (RCA Victor)
- 6 Un Buco Nella Sabbia, Mina (Fontana)
- 7 Goldfinger, Shirley Bassey (Odeon)
- 8 Pearly Shells, Billy Vaughn (Dot)
- 9 Walk Don't Run, Ventures (Liberty)
- 10 No Reply, Beatles (Odeon)
- 11 I Feel Fine, Beatles (Odeon)
- 12 Dynamite, Cliff Richard (Odeon)
- 13 Eight Days A Week, Beatles (Odeon)
- 14 Do The Cram, Elvis Presley (RCA Victor)
- 15 Se Piangi Se Ridi, Bobby Solo (Seven Seas)
- 16 Keep Searchin', Del Shannon (Stateside)
- 17 My Fair Lady, Sound-track (Columbia)
- 18 Love Portion #9, Searchers (Pye)
- 19 Mr. Moonlight, Beatles (Odeon)
- 20 Napoly Fortuna Mia, Gigliola Cinquetti (Seven Seas)
- 21 Ticket To Ride, Beatles (Odeon)
- 22 Tragic Wind, Chantays (Dot)
- 23 Long Tall Sally, Beatles (Odeon)
- 24 Caravan, Ventures (Liberty)
- 25 One Rainy Night In Tokyo, Belenda Lee (Decca)
- 26 L'Amore Ha I Tuoi Occhi, Yukari Ito (Seven Seas)
- 27 Karen, Surfari (Decca)
- 28 Since You Don't Care, Sylvie Vartan (RCA Victor)
- 29 Angelita, Los Marcellos Ferial (Durium)
- 30 Red Roses For A Blue Lady, Bert Kaempfert (Polydor)



Victor Publishing Co., Ltd. of Japan

13, 2 Chome, Misakicho Kanda, Chiyoda-ku
Tokyo, Japan.

Tel; (262) 1320, 2558, 6717, 0239, 6403

Cable Address; Victpublish Tokyo

KING RECORDS

**MOST PROGRESSIVE RECORD COMPANY IN JAPAN
DISTRIBUTOR OF THESE WORLD-FAMOUS LABELS**



NORWAY, DENMARK

STORYVILLE

FRENCH

BARCLAY

GERMANY

TELEFUNKEN

ARIOLA

ITALY

RICORDI

C. G. D.

JUKE BOX

S. A. A. R.

CETRA

HUNGARY

KULTURA

U. S. A.

ABC-PARAMOUNT

IMPULSE

COMMAND

GRAND AWARD

WESTMINSTER

WHITE HALL

VANGUARD

BACH GUILD

CONTEMPORARY

GOOD TIME JAZZ

CORAL

BRUNSWICK

WAIKIKI

MEXICO

ORFEON

VENEZUELA

DISCOMODA

ARGENTINA

DISC JOCKEY

MUSIC HALL

AUSTRALIA

FESTIVAL

G. BRITAIN

LONDON

FRENCH DECCA DEUTCH
DECCA SPAIN COLUMBIA
G. N. P. CRESCENDO
STAR DAY MONUMENT
FANTASY PARROT

ARGO

PORTUGAL

ALVORADA

BELGIUM

MOONGLOW

OLYMPIA

KING RECORD CO., LTD.

No. 1 2-CHOME, OTOWA-CHO, BUNKYO-KU TOKYO, JAPAN
Cable Address: KINGRECORD TOKYO TEL. (941)3111-6

JAPANESE BIGGEST HIT IN 1965

ONNA-GOKORO NO UTA

(BROKEN-HEARTED WOMAN)

BELONGS TO

SEVEN SEAS MUSIC CO., LTD.



CONTACT WITH US!! AT NOW!!
IF YOU WANT TO PROMOTE
YOUR COMPOSITION IN JAPAN

ADDRESS:
No. 1 2-CHOME OTOWA-CHO BUNKYO-KU, TOKYO, JAPAN
Cable Address: KINGRECORD TOKYO Tel (941) 3111

ZENONGAKUFU
SHUPPANSHA

ZEN-ON

THE
GREATEST & OLDEST
MUSIC PUBLISHERS
IN JAPAN

World wide Hits!
OZASHIKIKOUTA
FLOWERLY FACE

Address: No. 25 Higashigoken-cho, Shinjuku-ku, TOKYO JAPAN

Phone: (269) 0121-0127

Affiliated: OVERSEAS MUSIC PUBLISHERS Co., Ltd.

JAPAN—PUBLISHERS

ABERBACH TOKYO KABUSHIKI KAISHA
409, Zenkyoren Building
7, 2-chome, Hirakawa-cho
Chiyoda-ku, Tokyo

AKABOSHI MUSIC PUBLISHERS
(AKABOSHI ONGAKU SHUPPANSHA)
Kowa Building
17 Tsukudo-cho
Shinjuku-ku, Tokyo

CROWN MUSIC PUBLISHER, INC.
(KABUSHIKI KAISHA CROWN MUSIC
PUBLISHER)
Shinwa Building
1, 7-chome, Akasaka Tamachi
Minato-ku, Tokyo

EASTERN MUSIC PUBLISHING CO., LTD.
(EASTERN MUSIC KABUSHIKI KAISHA)
Kyowa Building
34 Shiba Kotohira-cho
Minato-ku, Tokyo

FAR EAST MUSIC PUBLISHING CORP.
(FAR EAST MUSIC PUBLISHING KABU-
SHIKI KAISHA)
258, 3-chome, Hyakunin-cho
Shinjuku-ku, Tokyo

INTERNATIONAL MUSIC PUBLISHERS
CO., LTD.
(KABUSHIKI KAISHA INTERNATIONAL
MUSIC PUBLISHERS)
Mansui Building
14, 3-chome, Kanda Ogawa-cho
Chiyoda-ku, Tokyo

JAPAN MUSIC PUBLISHERS, INC.
(NIHON ONGAKU SHUPPAN KABUSHIKI
KAISHA)
Kosokudoro Building
2, 1-chome, Ginza-Nishi
Chuo-ku, Tokyo

KAWAI GAKUFU CO., LTD.
(KABUSHIKI KAISHA KAWAI GAKUFU)
321, 2-chome, Komagome
Toshima-ku, Tokyo

KUSANO MUSIC, INC.
(YUGEN KAISHA KUSANO MUSICSHA)
Awaji Building
6, 2-chome, Kanda Awaji-cho
Chiyoda-ku, Tokyo

KYOGAKUSHA
(YUGEN KAISHA KYOGAKUSHA)
2, 2-chome, Haramachi
Shinjuku-ku, Tokyo

MUSIC PUBLISHER HIT MAKER, LTD.
(KABUSHIKI KAISHA HIT MAKER)
Keikanso Building
5, 1-chome, Shimomeguro
Meguro-ku, Tokyo

MUSIFON, INC. OF JAPAN
(MUSIFON KABUSHIKI KAISHA)
c/o FM Tokai
Hatsumei Building
17 Shiba Nishikubo-Akefuno-cho
Minato-ku, Tokyo

NEW ORIENT MUSIC INC.
(KABUSHIKI KAISHA NEW ORIENT ON-
GAKU SHUPPANSHA)
No. 17, 5, 1-chome, Hongo
Bunkyo-ku, Tokyo

NIPPON COLUMBIA MUSICAL ENTER-
PRISES LTD.
(COLUMBIA ONGAKU GEINO KABUSHIKI
KAISHA)
17 Akasaka Tango-cho
Minato-ku, Tokyo

ONGAKU SHUPPAN CENTRE CO., LTD.
TOKYO
(KABUSHIKI KAISHA ONGAKU SHUPPAN
CENTRE)
13, 2-chome, Hatsudai
Shibuya-ku, Tokyo

ONGAKUNOTOMOSHA CORP.
(KABUSHIKI KAISHA ONGAKUNOTOMO-
SHA)
30, 6-chome, Kagurazaka
Shinjuku-ku, Tokyo

OVERSEAS MUSIC PUBLISHERS CO., LTD.
(KABUSHIKI KAISHA KAIGAI ONGAKU
SHUPPANSHA)
26 Higashigoken-cho
Shinjuku-ku, Tokyo

SEVEN SEAS MUSIC CO., LTD.
(KABUSHIKI KAISHA SEVEN SEAS
MUSIC)
1, 2-chome, Otowa-cho
Bunkyo-ku, Tokyo

SHINKO MUSIC PUBLISHING CO., LTD.
(KABUSHIKI KAISHA SHINKO GAKUFU
SHUPPANSHA)
Awaji Building
6, 2-chome, Kanda Awaji-cho
Chiyoda-ku, Tokyo

SHINKYO MUSIC PUBLISHING CO., INC.
(YUGEN KAISHA SHINKYO ONGAKU
SHUPPANSHA)
c/o Teruchiyo Miyamoto
602, 3-chome, Nishisugamo
Toshima-ku, Tokyo

SUISEISHA
(KABUSHIKI KAISHA SUISEISHA)
30, 6-chome, Kagurazaka
Shinjuku-ku, Tokyo

TAIYO MUSIC, INC.
(TAIYO ONGAKU KABUSHIKI KAISHA)
No. 6-313, 30, 4-chome, Jingumae
Shibuya-ku, Tokyo

(Continued on page 66)

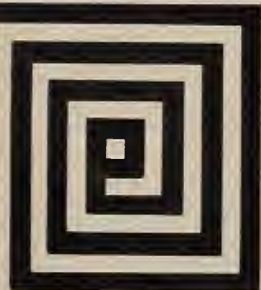

in JAPAN

the biggest, well-established publisher

ONGAKU-NO-TOMO SHA

and the active affiliates

SUISEI-SHA

TOA MUSIC CO.

6-30 kagurazaka, shinjuku-ku, tokyo



MIE NAKAO



THE PEANUTS



MICHIYO AZUSA



YUKARI ITOH

THE GREATEST ENTERTAINING ORGANIZATION IN JAPAN

PROMOTING MANY FAMOUS POPULAR TALENTS
TV, RADIO PRODUCING
SHOW AND STAGE PRODUCING
MOVIE AND RECORD PRODUCING
TALENT BOOKING



MARI SONO

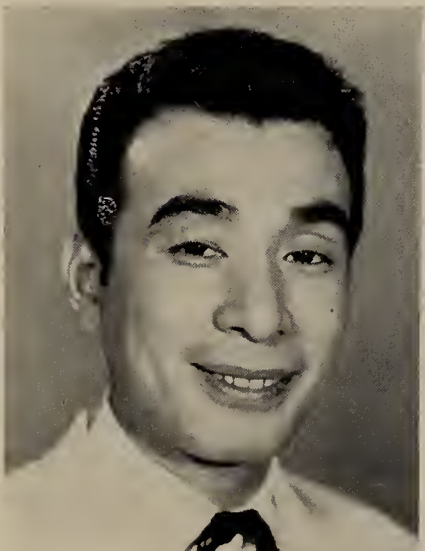

HITOSHI UEKI



MUSIC PUBLISHING

WATANABE PRODUCTION CO., LTD.

PRESIDENT: SHIN WATANABE
VICE PRESIDENT: MISA WATANABE



TAKASHI SHIKAUCHI



WATANABE MUSIC PUB. CO., LTD.

PRESIDENT: MISA WATANABE



NANA KINOMI

ADDRESS:
MATSUI BLDG., NO. 4 1-CHOME YURAKU-CHO
CHIYODA-KU, TOKYO, JAPAN TEL: (502) 0541-9
CABLE: WMUSICPUB, TOKYO

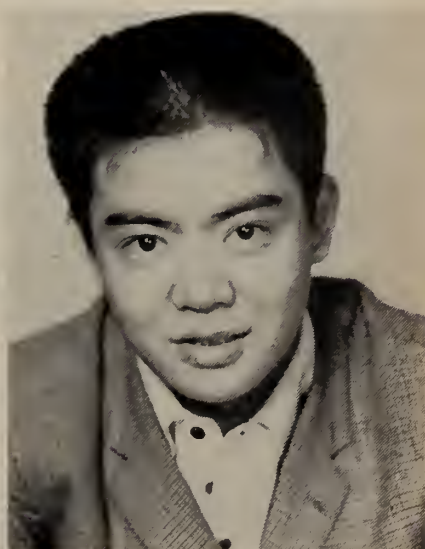

YASUO TANABE

**THE MOST ACTIVE PUBLISHER
PUBLISHING DIVISION
of
NIPPON COLUMBIA MUSICAL
ENTERPRISES, LTD.**

JUN IMAHORI
director

NO. 17 Tango-cho, Akasaka, Minato-ku
TOKYO, JAPAN.
PHONE: TOKYO (582)-8111, CABLE: NICOLME

JAPAN—PUBLISHERS

(Continued from page 64)

TOA MUSIC CO.
(KABUSHIKI KAISHA TOA ONGAKUSHA)
30, 6-chome, Kagurazaka
Shinjuku-ku, Tokyo

TOKYO MUSIC PUBLISHING CO.
(YUGEN KAISHA TOKYO GAKUFU SHUP-
PANSHA)
81, 2-chome, Kameido-cho
Koto-ku, Tokyo

TONE MUSIC CO., LTD.
(KABUSHIKI KAISHA TOON)
No. 17, 5, 1-chome, Hongo
Bunkyo-ku, Tokyo

TOSHIBA MUSIC PUBLISHING CO., LTD.
(TOSHIBA ONGAKU GEINO SHUPPAN
KABUSHIKI KAISHA)
30 Akasaka Tameike-cho
Minato-ku, Tokyo

VICTOR PUBLISHING CO., LTD. OF
JAPAN
(VICTOR SHUPPAN KABUSHIKI KAISHA)
13, 2-chome, Kanda Misaki-cho
Chiyoda-ku, Tokyo

WALT DISNEY ENTERPRISES OF JAPAN
LTD.
(WALT DISNEY ENTERPRIS KABUSHIKI
KAISHA)
Kanesaka Building
15, 2-chome, Shiba Tamura-cho
Minato-ku, Tokyo

WATANABE MUSIC PUBLISHING CORP.
(WATANABE ONGAKU SHUPPAN KABU-
SHIKI KAISHA)
Matsui Building
4, 1-chome, Yuraku-cho
Chiyoda-ku, Tokyo

ZEN-ON MUSIC PUBLISHERS CO., LTD.
(KABUSHIKI KAISHA ZEN-ON GAKUFU
SHUPPANSHA)
25 Higashigoken-cho
Shinjuku-ku, Tokyo

TOKYO MUSIC PUBLISHING CO., LTD.
(KABUSHIKI KAISHA TOKYO MUSIC)
Kotani Building
4, 1-chome, Yuraku-cho
Chiyoda-ku, Tokyo

GEI-EI MUSIC PUBLISHERS
(GEI-EI ONGAKU SHUPPAN KABUSHIKI
KAISHA)
Nakamura Building
23, 3-chome, Akasaka Shinmach
Minato-ku, Tokyo



Japan's

SHINKO

MUSIC PUBLISHING CO., LTD.

Music Publishing
Musical Books Publication
Instrument Deals
Monthly Popular Music Magazine
"THE MUSIC LIFE"

Address: 14 Ryogoku Nihonbashi, Chuo-ku, Tokyo.
Cable: Shinko Music Tokyo
TEL. (851) 2281 · 2282 · 2283 · 0969 (855) 9649
(253) 0661 · 0662 · 4011 (255) 1894

YOUNGEST
BRIGHTEST
AND
MOST ACTIVE



NEW ORIENT MUSIC INC.

IS
THE INDEPENDENT MUSIC COMPANY IN JAPAN
DOING
MUSIC PUBLISHING AND ALL THE MUSIC BUSINES

ADR. SANYO BLDG., NO. 17, 1-5 HONGO
BUNKYO-KU TOKYO JAPAN
CABLE/NEW ORIMUS TOKYO.TEL.812-7867

SUBSCRIPTION



Airmail-52 Issues

\$45—

MUSIFON. INC.

is a unique organization, and distributes products released by independant record producers under their own label to Japanese major record companies.

SEND

your copies right now !!

PLUS

Musifon, Inc. is an active music publisher in Japan



MUSIFON, INC.

Hollywood Office

6115 Selma Ave.
Hollywood, Calif. 90028
Tel. : Hollywood 4-7781
Cable: "MUSIFONIC" Hollywood

Tokyo Office

c/o FM Tokai Broadcasting
17, Akefuno-cho, Minato-ku
Tokyo, Japan
Tel.: 502-0431
Cable: "MUSIFON" Tokyo

Shin-nichi

PROMOTIONS, INC.

TOM NOMURA / President

Foremost Promotor In The Far East

Suzuyama Bldg.,
#6-46 Aoyama/Minato/Tokyo/Japan.
Tel: 401-6135-6
Cable Address: SHINNICHISHOW

أسعد صوت في العالم كله

LE SON
LE plus
JOYEUX
du MONDE
ENTIER

WISE

Fröhlichster
Klang der Welt

IL SUONE CHE PIÙ
ALLIETA IN TUTTO
IL MONDO

Ο ΠΙΟ ΕΥΧΑΡΙΣΤΟΣ
ΗΧΟΣ ΣΕ ΟΛΟΝ
ΤΟΝ ΚΟΣΜΟ

世界中で最もたのしい音

LAS NOTAS MAS
RADIANTES
DEL MUNDO
ANTIGRO

DET LYCKLIGASTE
LJUDET I HELA
VÄRLDEN!

הצליח העליון
בכל העולם

O MAIS
SESTIVO DE TODOS
OS SONS



Original Sound track Album Available Throughout the World on **RCA Victor**

The most trusted name in sound



AUSTRALIA - The Past Twelve Months

Ten years with the local product.

During the past twelve months, and the last six in particular, we have witnessed a revival in Australia of the Australian record, or what is loosely termed as the "Australian sound."

Most Australians in the record and publishing industries figure that any sound that sells is the ideal sound of the moment, and they are all now looking towards the sudden renewed consumer interest in the local product as the key to future success.

Some ten years ago, the record companies who were then interested in local talent, got away to quite a shaky start with what were then considered as the best records ever produced in Australia.

From these humble beginnings, the local scene slowly but surely developed in the face of mounting odds, to the stage where a sprinkling of Australian produced singles began to catch a slice of air play. They then started to snare some sales, and—hey presto! the local disc had arrived.

These were the early days of the industry in Australia, the early days of artists such as Col. Joye, Johnny O'Keefe, Johnny Chester, The Thunderbirds, etc.

The record business owes a great deal to artists like these and their early records, which pioneered the way for the present high standard of quality and acceptance of the Australian record today.

Just how important these early records were, may never be known. They started a trend that has opened a new world of great dimensions for Australian talent, composers, and records—a world that is conquering new fields almost every other day, as Australians generally continue to make their presence felt on the international pop music scene.

There was always great joy when, in these formative years, a locally produced record hit the big time in popularity—joy that was usually shared by the entire industry, regardless of which label carried the lucky record, which in those days was usually one of the Festival group to break through on a national scale.

Main competition to the local product in the late 1950's came from American masters, which had something of a stranglehold on the singles market of Australia.

After a few years of fluctuating fortunes during which the number of "dogs" far outstripped the number of successful records, (just as they do today) the local industry took stock to find that it was on the credit side of the deal—but not by much! It seemed that all the time, money, and effort, and general anxiety over the local "baby" was hardly warranted by the results.

This period of some uncertainty took us into the early 1960's when there was no definite trend one way or the other.

THEN, almost as if a pre-determined signal had been set off, the entire local industry rose again with new life, excitement, action and vigor. To the old heads in the business, it was as though an enormous meeting had been called of the entire trade to consider the future of the local output, and a vote of confidence resulted.

We believe that this period in the early 60's will go down as one of the most crucial of all in relation to the Australian product. We know for sure that a couple of the biggest supporters of the Australian field were on the brink of throwing-in-the-towel and concentrating solely on overseas catalogues. Fortunately these companies gave the problem second thoughts, and decided to stick with the "recorded-in-Australia" policy.

They embarked on a programme of expansion and betterment with such enthusiasm that their outlook began to rub off on others in the trade. We found recording companies building, remodeling, re-equipping, re-planning and re-shaping their whole operations to give far more accent to Australian music and artists. Music publishers were suddenly more readily interested in Australian compositions because they found there were more and better opportunities to have local repertoire recorded by some important name artists.

With better records came better songs (should it be vice-versa?) which culminated in an improved product on disc, which, of course, led to greater and wider acceptance by disc jockeys and radio stations across the nation.

Television began to take a renewed interest in this Australian talent which was competing more than favourably on record with overseas material. From here the whole thing snowballed in acceptance and popularity to the great stage where the Australian artists actually "had-it-made" in their own country.

THEN, just when things were looking nice and rosy for Australia; WHAM! It suddenly happened and hit us like a thunderbolt! We refer of course to the English invasion which dominated our industry to the same extent (perhaps a little more so) as it did in most English-speaking countries. This really put a dent in the progress of Australian material, a decent sized dent it was too—one that almost brought local activity to a standstill. During those early months of the English "take-over" it was almost impossible to GIVE an Australian record away; let alone try and sell it. BUT, like they say, you fight your hardest when you're down, and again the Australian proved his ability to fight back, and this time he had the advantage of having survived a couple of similar bad periods a few years beforehand. The fightback against the English domination wasn't (isn't) easy. We were the first country outside England to give mass acceptance to English hit singles. Many of their Mersey-Beat Discs had enjoyed tremendous popularity here some twelve months before the identical records gained world-wide recognition. In fact, the universal recognition only served to re-activate interest in those same records again throughout Australia, which gave them a second bite at our market.

The question in the record industry around the world was "what to do to compete with English records?" (Let it be understood here and now that we are not complaining about the success of the English product—many companies have profited handsomely from them. But there was still an important local industry to be kept alive). It seemed to Australian trade executives that America failed to a large extent in its efforts to play the English at their own game. America's greatest success has been achieved in the field in which they have always been supreme—that of the big arrangement sing-along standard type of thing such as artists like Vic Damone, Frank Sinatra, Bobby Vinton and Dean Martin have been scoring heavily with of late.

Contrary to the American experience, Australia found the answer to English sounds in re-creating those sounds to a strong degree. Could this have been partly due to our long-time English heritage and years of English tradition and influence in our background? No matter what the reason, Australian records found the answer and began "sharing" our market with English records. Since that time of a couple of years back the local record industry has advanced in

great style to the stage now where any record company which isn't producing Australian records must be having its share of headaches. We don't for one minute suggest that companies with local product are hauling in great piles of cash, but at least they are in a better position than they would be without their Australian discs.

EMI, who have been a little reluctant to enter the local singles field on a scale the trade would expect, are now showing much more interest and action but still not to the volume anticipated from an organization of their size and depth. Festival Records (and their subsidiaries) and W & G Records are two of the local companies who have really pioneered the Australian single, and between them they would account for at least 60% of the entire output of local issues. Astor Records, who have been in and out of the local scene over the years, are now making a determined bid for a big slice of the market with their GO!! label.

RCA, who were among the last into the field, are continually building their Australian catalogue, especially in relation to singles.

As yet, Philips haven't done much locally but the feeling is that they are getting their operation geared for a solid entry into the market.

Australian Record Company (CBS) are rapidly building their contribution to the Australian scene, their activities cover both albums and singles and the company has had fairly good results.

With this great revival of action on the local product has come a big batch of new artists; and the new talent is scoring success in the sales department. A few weeks ago our list of the ten best-selling singles across Australia included five locally produced records. Each one featured an artist who had risen to prominence within the last twelve months. There is no doubt that the older and more established name artists are finding the going tough with singles; in fact many of them have given up trying to crack the singles market.

The average Australian-produced single has much stiffer competition than those in England or the United States. The reason being that our local output has to do battle with the best from BOTH America and England; and you may rest assured that amounts to very formidable competition indeed. Where the American single in America only has to compete with the best from the U.K.; and vice-versa in relation to the English produced single. They don't have the best from TWO other countries in opposition.

The only important thing missing from the Australian scene for years has been the lack of support and interest from overseas labels, who it appears are most reluctant to give an Australian record a chance even if it has been a smash right across our country. One would think that the international success of Australian talent such as Frank Ifield, Rolf Harris and currently The Seekers, would have stimulated an eagerness on the part of overseas record labels to find out what else was available from Australia. There are several singles currently out that are more than worthy of the deepest consideration by overseas companies.

We've had a look at the Australian record industry over the past ten years or so. We hope it has made you a little more familiar with the Australian operation; and we hope also that the overseas trade may benefit from what has been said.



W & G RECORD PROCESSING CO. PTY. LTD.

Distributing and Manufacturing

**AMERICA'S TOP HITS
IN AUSTRALIA AND NEW ZEALAND**

If you are looking to find strong distribution and top notch representation for your record line, You Are Making A Wise Choice In Selecting W & G RECORD PROCESSING CO. PTY. LTD. To Handle Your Line In Australia. W & G is Australia's Largest INDEPENDENT-MAJOR Company with its own Pressing Plants and Distributors. COME! JOIN OUR HAPPY FAMILY Of American and Foreign labels we already Handle.

ALSO: Look to the New Australian Trend shaping up World Wide. In 1965 W & G Leads the way with "THE SEEKERS" an Original product of Australia and first recorded and introduced by W & G RECORDS.

W & G AUSTRALIAN ARTISTS That will lead the way on The American Charts in 1966 Include . . . ★MERV BENTON ★PAT CARROLL ★COLIN COOK ★KEVIN SHEGOG ★DOUG OWEN ★JOHNNY CHESTER

"IN AUSTRALIA IT'S W & G ALL THE WAY"

American Office:
JAMES N. PARKS

Australian Office:
RON J. GILLESPIE

W & G RECORD PROCESSING CO. PTY. LTD.

852 Elm Street
Manchester, N.H., U.S.A. 03101
Tel. 603-623-9749

185-187 A'Beckett Street
Melbourne, C1., Australia
Tel. 329-7255

AUSTRALIAN RECORD COMPANIES

ASTOR ELECTRONICS PTY LTD.
161-173 Sturt Street,
South Melbourne,
Victoria.
Phone: 690300. Cables—Schuh, Melbourne.
Labels: Astor, Reprise, Verve, Colpix, Goll,
Red Bird, Vanguard.

AUSTRALIAN RECORD COMPANY, LTD.
11-19 Hargrave Street,
East Sydney.
New South Wales.
Phone: 314111. Cables—Discosound, Sydney.
Labels: CBS, Warner Bros, United-Artists,
Chess, Knapp, Hickory.

EMI (AUSTRALIA) LTD.
301 Castlereagh Street,
Sydney.
New South Wales.
Phone: 20912. Cables—Emitron, Sydney.
Labels: HMV, Columbia, Capitol, Decca, London,
Parlophone, Vocalion, MGM, Disneyland,
Liberty, Stateside, Cameo, Parkway.

FESTIVAL RECORDS PTY LTD.
223-229 Harris Street,
Pyrmont.
New South Wales.
Phone: 684021. Cables—Festival, Sydney.
Labels: Festival, Vox, 20th Century-Fox,
Coral, Dot, Westminster, Leedon, Ampar, At-
lantic, Impulse, Brunswick, Ember, Command,
Sunshine.

PHILIPS ELECTRICAL INDUSTRIES PTY LTD.
69-79 Clarence Street,
Sydney.
New South Wales.
Phone: 20233. Cables—Argenta, Sydney.
Labels: Philips, Polydor, Deutsche Grammo-
phon, Fontana, Mercury, Riverside, Wing.

RCA OF AUSTRALIA PTY LTD.
221 Elizabeth Street,
Sydney.
New South Wales.
Phone: 618541. Cables—Radiointer, Sydney.
Labels: RCA, RCA Victrola, Vik, RCA Cam-
den.

W & G RECORD PROCESSING CO PTY LTD.
185-187 A'Beckett Street,
Melbourne.
Victoria.
Phone: 3297255. Cables—Dualscale, Melbourne.
Labels: W & G, Time, Gem, Diaphon, In.

AUSTRALIAN MUSIC PUBLISHERS

ACCOLADE MUSIC CO PTY LTD.
91 Grace Street,
Forestville,
New South Wales.

ACUFF-ROSE PUBLICATIONS.
Box 513 J, GPO Melbourne,
Victoria.

J. ALBERT & SON PTY LTD.
137-139 King Street,
Sydney
New South Wales.

ALLANS MUSIC (AUSTRALIA) PTY LTD.
Box 513 J, GPO Melbourne,
Victoria.
This company also handles BIEM and GEMA.

APOLLO MUSIC PTY LTD.
161-173 Sturt Street,
South Melbourne,
Victoria.

BELINDA MUSIC (AUSTRALIA) PTY LTD.
321 Pitt Street,
Sydney,
New South Wales.

BOOSEY & HAWKES (AUST) PTY LTD.
250 Pitt Street,
Sydney,
New South Wales.

CASTLE MUSIC PTY LTD.
301 Castlereagh Street,
Sydney,
New South Wales.

CHAPPELL & CO LTD.
68-70 Clarence Street,
Sydney,
New South Wales.

D. DAVIS & CO PTY LTD.
Box 513 J, GPO Melbourne,
Victoria.

ESSEX MUSIC OF AUSTRALIA PTY LTD.
324 Pitt St.,
Sydney,
New South Wales.

LEEDS MUSIC PTY LTD.
324 Pitt St.,
Sydney,
New South Wales.

W. H. PALING & CO. LTD.
338 George Street,
Sydney,
New South Wales.

NICHOLSON'S PTY LTD.
416 George Street,
Sydney,
New South Wales.

SOUTHERN MUSIC PUBLISHING CO. (A/SIA) PTY LTD.
38-40 York Street,
Sydney,
New South Wales.

SPANKA MUSIC PTY LTD.
185-187 A'Beckett Street,
Melbourne,
Victoria.

WOOMERA MUSIC PTY LTD.
185-187 A'Beckett Street,
Melbourne,
Victoria.

WORLD WIDE MUSIC DIRECTORY

(Continued from page 46)

HUNGARY

COLLECTING SOCIETIES

ARTISJUS-SZEROI JOGVEDO HIVATAL IBUREAU HONGROIS POUR LA PROTECTION DES DROITS D'AUTEUR—Nyar u. 6—BUDAPEST VII
Phone: 429-580
Cable: ARTISJUS BUDAPEST
Pres.: Mr. Paul Kadosa
Gen. Mgr.: Dr. István Tilmár

EXPORT & IMPORT

KULTURA—HUNGARIAN TRADING CO.—P. O. Box 149—BUDAPEST 62
(Fo-u 32—Budapest 1)
Phone: 159-450
Cable: KULTURPRESS BUDAPEST
Man. Dir.: Mr. Andras Svéd
Only organization to be contacted in question of export or import of ready-made cultural goods (records and sheet music editions).

MUSIC PUBLISHERS

ZEMENÜKIADÓ VALLALAT-EDITIO MUSICA—5 PF. 322—BUDAPEST V
(Semmelweis-utca 1-3—Budapest V)
Phone: 187-990
Director: Mr. Bela Tardos

RECORD MFRS

MAGYAR HANGLEMEZGYARTO VALLALAT QUALITON HUNGARIAN GRAMOPHONE RECORDS P.O. Box 49—BUDAPEST 53
(Semmelweis-utca 1-3—Budapest V)
Phone: 187-990
Cable: QUALITON BUDAPEST
Pres.: Mr. Jenő Fehérvári
Labels (domestic): Qualiton

FRANCE—

The Past Twelve Months

(Continued from page 54)

JUNE

This month began with two really interesting events for jazz fans. We saw at the Salle Pleyel organist Jimmy Smith with his trio, and a week after that Louis Armstrong gave two concerts at the Palais des Sports before 12,000 Parisians. Great success for both. "The Birds and the Bees" had two french treatments: Donald Lautrec (Fontana) records a version titled "Tu Dis Des Bêtises." The Monty's one is titled "Bientot Les Vacances." French author Georges Aber wrote the two lyrics. Eddie Barclay was in the U. S. He signed a contract for a Jacques Brel's appearance at Carnegie Hall on December 4. Vogue prexy, Leon Cabat, returned after a U. S. trip. Sandy Shaw came to Paris for several TV programs and at the same time Françoise Hardy was in Greece for a film in which she co-starred with Samy Frey. Publishing group Francis Day had great success with music from film "Zorba le Grec." Marie Laforet recorded a new EP with "Katy Cruelle." "La Bague Au Doigt," "Ma Chanson Faite Pour Toi." Jean Jacques Debout flew to London and recorded an EP directed by Tony Hatch. Alain Boublil, Vogue International manager, went to the English Festival in Brighton. He brought back two unpublished songs. In Paris, Lyon and Nice we saw the Beatles. They are a fantastic success for all their appearances. We also saw The Yardbirds and Lord Sutch.

JULY

Two important festivals this month in the same city: Antibes-Juan les Pins. At the beginning of the month there was "La Rose D'Or De La Chanson." It is the second year for this young festival. Every important publishing group presented one or two songs. Winner was Eric Montry. The songs he presented had been written by Frank Gérald, Pierre Delanoé and Hubert Giraud. Titles were: "D'Ombre Et De Soleil," "Le Bar Du Dernier Verre" by Francis Lemarque and "Les Cloches D'Ecosse" by Jean Jacques Debout and "Il Y A Cent Mille Raisons" by Michel Mallory. Second Festival was Jazz. We heard John Coltrane and Nina Simone. Everybody in show-business went to the Eddy Barclay marriage. The new Mrs. Barclay is 18 years old and an actress. Henri Salvador, through his own label Rigolo, just released a funny version of "La Danse De Zorba" ("Zorba's dance"). Le Trio Athénée fly to the U. S. to appear on the Ed Sullivan Show.

ICELAND

COLLECTING SOCIETIES
S.T.E.F.—SAMAND TÖNSKLÁDA OG EIGENDA FLUTNINGSRÉTTAR—Freyjugatu 3—REYKJAVIK
Phone: 16173
Cable: STEF REYKJAVIK
Pres.: Mr. Jón Leifs
Performing Rights Society

MUSIC PUBLISHERS

BÓKAÚTGÁFA MENNINGARSJÓDS—Hvefströgútu 42—REYKJAVIK
Phone: 13652
Pres.: Mr. Gils Gudmundsson

DRANGEYJARÚTGÁFAN—Laugavegi 58—REYKJAVIK
Phone: 13311
Cable: AMMENDRUP REYKJAVIK
Pres.: Mr. Tage Ammendrup

RECORD MFRS

FALKINN H/F—Laugavegur 24—REYKJAVIK
Phone: 18670
Cable: FALKINN REYKJAVIK
Pres.: Mr. Haraldur V. Olafsson
Labels (domestic): His Master's Voice, Parlophone
Labels (others): Capitol, Columbia, Electrola, Imperial, Liberty, M.G.M., Odeon, Pathe, Stateside, Vox.

HLJÓDFAERAHUSID REYKJAVIKUR—Hafnastæti 2 REYKJAVIK
Phone: 13656
Pres.: Mr. Niels Jørgensen
Labels (others): Coral, Decca, Deutsche Grammo-
phon, Heliodor, Polydor, Telefunken, United Artists,
Verve

HLJÓDFAEREVERZLUN SIGRIDAR HELGADÓTTIR—Vesturvegi—REYKJAVIK
Phone: 11315
Cable: MUSIC REYKJAVIK
Pres.: Mr. Helgi Hjálmsón
Labels (domestic): H.S.H.
Labels (others): Atca, Atlantic, Cupol, Dot, Fontana,
Musica, Philips, RCA Victor

VERZLUNIN DRANGEY—Laugavegi 58—REYKJAVIK
Phone: 13311
Cable: AMMENDRUP REYKJAVIK
Pres.: Mr. Tage Ammendrup
Labels (domestic): Íslenzkír Tónar, Stjórnú Hljóm-
plátur
Labels (others): California, Dot, Decca, London,
Polydor, RCA Victor.

INDIA

RECORD MFRS

HINDUSTHAN MUSICAL PRODUCTS LTD.—6/1 Akur Dutt Lane—CALCUTTA-12
Phone: 24-1422
Cable: HEMPIVUS CALCUTTA
Man. Dir.: Mr. C. C. Saha
Labels (domestic): American Phone, Hindusthan,
Kahinoor, Star Hindusthan, Suralekha, Taj, Vikash
Geet, etc.

INDONESIA

RECORD MFRS

THE INDONESIAN MUSIC CO. IRAMA MUSIC—7B, Tjikini Raja—DJAKARTA
Phone: Gambir 1892
Cable: IRAMA DJAKARTA
Pres.: Mr. Sujoso Karsono
Labels (domestic): Demand, Irama

ISRAEL

COLLECTING SOCIETIES

ACUM LTD.—SOCIETE D'AUTEURS, COMPOSITEURS ET EDATEURS DE MUSIQUE EN ISRAEL—P.O. Box 11201—TEL AVIV
(11B-120 Rotschild Boulevard—Tel Aviv)
Phone: 22 01 05, 22 58 63
Cable: ACUMEMIS TELAVIV
Pres.: Mr. Aharon Ashman, Mr. Menahem Avidom
Mechanical Licenses and Performing Rights Society

MUSIC PUBLISHERS

ILLAN MELODY PRESS—P.O. Box 6011—TEL AVIV
(Rehov Ben Yehuda 59—Tel Aviv)
Phone: 23 20 78
Cable: ISMUSICA TELAVIV
Pres.: Dr. Peter Gradenwitz

ISRAEL COMPOSERS LEAGUE PUBLICATIONS (I.C.L.P.)—P.O. Box 11180—TEL AVIV
(24, Pinkas Street—Tel Aviv)
Phone: 43986
Pres.: Mr. M. Avidom

ISRAEL MUSIC INSTITUTE (I.M.I.)—P.O. Box 11253—TEL AVIV
(26, Zamenhoff Street—Tel Aviv)
Phone: 234.397
Director: Mr. William Elias

ISRAELI MUSIC PUBLICATIONS LTD.—P.O. Box 6011—TEL AVIV
(Rehov Ben Yehuda 59—Tel Aviv)
Phone: 23 20 78
Cable: ISMUSICA TELAVIV
Pres.: Dr. Peter Gradenwitz

ISRAZEMER—P.O. Box 4292—HAIFA
(20, Haneviim Street—Haifa)
Phone: 699.50
Cable: RECOMUSIC HAIFA
Pres.: Mr. Dov Zeira

RECORD MFRS

EASTRONICS LTD.—P.O. Box 2554—TEL AVIV
(22, Maaze Street—Tel Aviv)
Phone: 66890
Cable: EASTRONIX TELAVIV
Man. Dir's.: Mr. T. Kenny & Mr. D. Peleg
Labels (domestic): RCA Victor

GAL RON LTD.—94, Allenby Road—TEL AVIV
Phone: 66262
Mgr's.: Mr. Avraam Zbarowski & Mr. Issachar Levy
Labels (domestic): Ron-Li, Warner Bros.
Labels (others): Barclay, Decca, O.S.I.

HATAKLIT LTD.—P.O. Box 4292—HAIFA
(20, Haneviim Street—Haifa)
Phone: 699.50
Cable: RECOMUSIC HAIFA
Pres.: Mr. Dov Zeira
Labels (domestic): Golden Classical, Hataklit, Teen,
Top Hits
Labels (others): Atlantic, Cadence, Calpix, Collec-
tor's Guild, Imperial, Laurie, Roulette, Swan,
Tikva, Vox.

HED-ARZI LTD.—4, Hilazon Street—RAMAT-GAN
Phone: 72.2003
Cable: HEDARZI RAMATGAN
Pres.: Mr. Zeev Lewin & Mr. Josef Grosman
Labels (domestic): Arton, Hed Arzi
Labels (others): ABC Paramount, Barclay, Decca,
Mercury, M.G.M., Vanguard.

HERBERT RUSSCOL RECORDS—1, Ben Yehuda Street—TEL AVIV
Phone: 56656
Pres.: Mr. Herbert Russcol
Labels (domestic): Studio
Labels (others): Ariola, Cameo, Parkway, Vogue

MAKOLIT LTD.—P.O. Box 8031—TEL AVIV
(15 Hamaor Street—Tel Aviv)
Phone: 821.694
Pres.: Mr. Daniel Antanir
Labels (domestic): Carlophone, Gamadon, Makolit
Labels (others): Embassy, Hispavox, IMC, Palette

THE PALESTINE ORIENT CO., LTD.—P.O. Box 230—TEL AVIV
(14, Herzl Street—Tel Aviv)
Phone: 57557
Cable: PALORIENT TELAVIV
Pres.: Mr. Y. Kimchi
Distributor of all EMI labels

IVORY COAST

RECORD MFRS

COMPAGNIE FRANCAISE DE L'AFRIQUE OCCIDENTALE—Boite Postale 127B—ABIDJAN
(Avenue Hondaillé—Abidjan)
Phone: 25-51
Cable: SENAFRICA ABIDJAN
Pres.: Mr. L. Morelon
Labels (domestic): Rapi
Labels (others): Decca, Pathé, RCA Victor, Telefun-
ken, Voix de Son Maitre, Vogue, Warner Bros.

DISCOR—Boite Postale 5392—ABIDJAN
(Avenue General de Gaulle—Abidjan)
Phone: 37-06
Pres.: Mr. Safye Deen
Labels (domestic): Discar

LA MAISON DU DISQUE—Boite Postale 67—ABIDJAN
(Avenue Delafosse—Abidjan)
Phone: 22239, 55135
Labels (domestic): Philips
Labels (others): Barclay, Bel Air, Deutsche Gram-
mophon, Polydor, etc.

JAMAICA

RECORD MFRS

RANDY'S RECORD MART—17 North Parade—KINGSTON
Phone: 24859
Cable: RRM KINGSTON
Pres.: Mr. Vincent "Randy" Chin
Labels (domestic): Creative Calypso, Pops, Randy's
Record

WEST INDIES RECORDS LTD.—13 Bell Road—KINGSTON 11
Phone: 37340
Cable: WIRL KINGSTON
Chairman: Mr. Clifford Rae
Man. Dir.: Mr. George Benson
Labels (domestic): Check, Fire, Giant, Muzik City,
ND, Son, WIRL
Labels (others): Columbia, Dot, M.G.M., VeeJay,
Verve, Epic, Decca, Word, Crown.

PRESSING PLANTS

WEST INDIES RECORDS LTD.—13 Bell Road—KINGSTON 11
Phone: 37340
Cable: WIRL JAMAICA
Man. Dir.: Mr. George Benson

JORDAN

RECORD MFRS

PETER B. PETRIDIS—P.O. Box 336—AMMAN
(King Hussein Street—Amman)
Phone: 26123
Cable: PETRIDIS AMMAN
Pres.: Mr. Peter B. Petridis
Labels (domestic): Voice of Jordan, Voix di Liban,
Voix du L'Orient
Labels (others): Capitol, Columbia, His Master's
Voice, Kapp, Liberty, M.G.M., Mode-Durium, Parlo-
phone, Pathé, RCA Camden, RCA Italiana, RCA
Victor, Soutelphon, Stateside, United Artists, Verve,
Vik, Vogue Pop, Warner Bros.

TRANSJORDAN ENGINEERING CO., LTD.—P.O. Box 1—AMMAN
(Shabsough Street—Amman)
Phone: 241.92/6
Cable: TEC AMMAN
Pres.: Mr. Tewfik M. Kattan
Labels (others): Barclay, Philips

KENYA

RECORD MFRS

AFRICAN MERCANTILE CO. (OVERSEAS) LTD.—P.O. Box 30010—NAIROBI
(Standard Street—Nairobi)
Phone: 212.81
Cable: NAVIGATION NAIROBI
Dir.: Mr. C. M. Bourne
Labels (others): Capitol, His Master's Voice, MGM
After Jan. 1, 1963 handling records from EMI-
India only

AFRICA RECORD CO.—P.O. Box 1078—NAIROBI
(River Road—Nairobi)
Phone: 240.30
Partners: P. C. Vedi, B. D. Puri, H. V. Chhaya &
K. H. Chauhan
Labels (domestic): Africa
(Continued on page 85)

HOLLAND – The Past Twelve Months

Phonogram reports a further increase in business during the season 1964/65. Of course, singles and EP's have a big market in Holland, but the LP record especially is quickly reaching top turnovers, and not solely as a result of the introduction of cheaper series (Hfl.9.90 is a very popular price for a classical 12 inch LP nowadays). The more expensive series are also doing great business. Of course, the low-priced LP did a great job as a stimulator to reluctant classical buyers. It must be noted that the 10" LP has practically disappeared from the market. Of the 1964 Edisons, Phonogram got no fewer than ten awards, five in the classical and five in the pop field.

The repeated visits of the famous French vocal group The Swingle Singers, led by American Ward Swingle, made a tremendous impact on the Dutch audiences. Popular teen-age-singer Anneke Grönloh (five Golden Records) just started a season in René Sleswijk's "Nederlandse Revue" (a very popular show, already in its 28th year), in which she is a featured singer, accompanied by big orchestra, choir and dancers. It should be a very big chance for the young girl. Big stars like Corry Brokken and Mieke Telkamp were on the Sleswijk stage in earlier years. Saxophonist-clarinetist Herman Schoonderwalt received, for the first time, the 1965 Big Prize for Dutch Jazz. Philips recorded him, with several combinations ranging from quartet to big band, on an LP, "The Winner." Erroll Garner visited Holland and recorded an LP in the famous Concertgebouw Hall in Amsterdam. Jazz-Singer Rita Reys, ten years on Philips-records was honoured in recording a special LP with the Pim Jacobs Trio and several guest artists, "Congratulations in Jazz." Tango composer and orchestra leader Malando, in the business for more than 25 years, flew with his entire orchestra to Japan, because of the enormous successes of their records in that

country. Trip was organized by Philips and KLM and proved a very big hit. Golden Records were handed to young Willeke Alberti, biggest teenage talent of the moment, for her recording of "Mijn dagboek" "My diary": They recorded the song also in English and to Roy Orbison for the tremendous sales of his "Pretty Woman." Famous "Star Club" records were added to Phonogram's library, on which the Liverbirds, Lee Curtis, the Searchers, the Nashville Teens, the Rattles and others are recording. Furthermore, Vee-Jay is represented on the Dutch market by Fontana, and already imported records by Eric Dolphy, Wayne Shorter, Walter Perkins, Frank Strozier and others. Riverside scored a big hit with its Classic Jazz-Masters series. Fontana released a similar series, "Folk Blues USA." In the classical field, Decca released a marvelous recording of Bach's "Matt-häus Passion," directed by Karl Münchinger, and with soloists like Peter Pears, Hermann Prey and Dutch soprano Elly Ameling. Another important Phonogram release were the Claudio Arrau recordings of Beethoven's Piano Concertos on Philips.

There are many highlights during season 1964/65 that symbolize the constant growth of Gerry Oord's Bovema in Holland. According to the label's president, the most recent and important ones are the now completed removal of record stores and other depts to newly-erected buildings neighbouring the pressing plant, through which operation a higher commercial efficiency could be obtained, and the recent take-over of such important labels as Parlophone and Odeon. This enables Bovema to enlarge its firm grip on the Dutch record market, in accordance with which, sales and net proceeds will be considerably increased. Even a bird's-eye view over the past season spotlights such successes as Bovema's Annual Convention at the Amsterdam-Hilton, featuring many prominent art-

ists and guests, and the Edison-Award for popsinger Adamo, who also got a unique Diamond record for his "Vous Permettez Monsieur" hit. Gold was given to Imperial's songstress Imca Marina for her "Lass Mein Herz Nicht Weinen." The Columbia and HMV labels took their happy share in steady-selling British beat groups such as Manfred Mann, Herman's Hermits, Gerry and the Pacemakers etc. Bovema's Liberty label booked peak-sales for P. J. Proby and Vic Dana, the latter reaching a unique 15,000 sales mark for his "Red Roses." Capitol did tremendous business with Buck Owens, the late Nat King Cole and the Beach Boys, and Atlantic is in an upward move with its r & b catalogue and the Drifters. Bovema's HMV label hit the charts with Dutch and German versions of Toon Hermans' One Man (TV-) Show and also noted the definite 'arrival' of the Shepherds as Holland's most outstanding folk group. Gramophonehouse's large classical standard repertoires continued raking in healthy sales and especially Columbia's highly attractive Claudio Arrau Beethoven series was an especially huge success. The company's promotional activities reached a peak with Bovema's participation in the British Week, the organisation of Bovema Coop-Talent contests throughout this country, resulting in 15 year old Ad van Yperen's remarkable record-debut with a Dutch version of 'Il Silenzio', as well as a series of great Adamo-shows. A constant plugging of all pop records and artists on Dutch radio, TV and music press may well round-off this short survey of Bovema-highlights during a business-year to remember!

Polydor Nederland N.V. opened its offices in The Hague at the beginning of past season with a well-attended party. Polydor is very happy to have at the end of this season Holland's number one hit, "Woolly Bully," by Sam The Sham And The Pharoahs.

CNR and Telefunken had an extremely successful season with big sellers like Dutch singer Gert Timmerman and British beat-group the Scorpions which is recording exclusively for CNR. Timmerman was awarded with platinum and gold disks (presented to him by Louis Armstrong!), signifying the respective sales of "Ik Heb Eerbied Voor Jouw Grijze Haren" (200,000 sales) and "Nimm Deine Weisse Gitarre" (100,000). The Scorpions made a big topper with "Hello Josephine." Latest signing of CNR is Dutch-Danish star Suzie, one of the Dutch team that won this year's Knokke Song Festival.

Dureco had big hits with "Liebeskummer Lohnt Sich Nicht" by Siw Malmkvist (60,000 records sold), "Let-kiss" by Gudrun Jankis (more than 100,000 sold in Benelux) and records by the Zangeres Zonder Naam (Singer Without A Name) (100,000). Metro-nome's "Brilliant" series, priced \$2.75, proved to be good selling, especially the LP of Nina and Frederik. Dureco also had a big moneymaker (and still has!) with Duo Akropolis' version of "Zorba The Greek." Turnover of Dureco in 1964 was 150% in comparison with 1963.

Basart and Stibbe made good business of course with the exploitation, until last June, of all Beatles Parlophone hits. Also, Durium's "Il Silenzio" (by Nini Rosso) proved to be a big hit.

The past year has been the most successful one so far in the rather short history of the N. V. Negram label in Haarlem. In the past months, N. V. Negram was characterized by a progressive way of working, both in the release policy and in the field of publicity. A very favourable circumstance was the fact that the labels which are represented by this company, were very lucky as regards their hit repertoire. Another favourable circumstance was the addition of the Reprise and Warner Bros. labels.

(Continued on page 72)

EDITIONS

- MOROTONE
- MARANGE MUSIC
- MONTANA INTERNATIONAL
- VOGUE INTERNATIONAL HOLLAND
- LIONS MUSIC CORP.
- CAPRIOLE

we are growing out of our clothes, that's why we are moving to a new place:



**NOW
IN OUR
OWN
BUILDING**

WE ARE MOVING TO HEEMSTEEDSE DREEF 287—HEEMSTEDE

PHONE 83654—HEEMSTEDE—HOLLAND

3 GOLDEN RECORDS in 1964!



- ADAMO: Vous permettez, Monsieur
- THE BEATLES: Love me do
- IMCA MARINA: Lass mein Herz nicht weinen
- SIW MALMKVIST: Liebeskummer
- WILLEKE ALBERTI: Le sifflet des Copains
- ROCCO GRANATA: Melancholie
- COCKTAIL TRIO: Pretka Jenka
- SWINGING BLUE JEANS: Hippy Hippy Shake
- HERMAN'S HERMITS: Wonderful world

- GITTE & REX GILDO: Hokus Pokus
- CONNY FROBOESS: Meine Hochzeitsreise
- THE PEANUTS: Souvenirs aus Tokio
- UDO JURGENS: Warum, nur warum?
- SUZIE: Max und Moritz
- WANDA JACKSON: Santo Domingo
- TRINI LOPEZ: Bye, Bye Blondie
- GESCHWISTER JACOB: So einen Boy
- ROD MCKUEN: The Lovers
- CLIFF RICHARD: Let's make a memory
- THE MOTIONS: It's gone

ANAGON

SCHALSTONE HOLLAND

HOLLAND'S

GERRY OORD

PROVIDES

NEW OFFICES

NEW LOOK



FOR GREATER
**SALES —
PROMOTION**

IN HIS

**UNIQUE
WORLD
FAMOUS
INDEPENDENT
COMPANY**

BOVEMA



NEW SHOWROOMS

BOVEMA-HOLLAND
HEEMSTEDE — PHONE 750



HOLLAND - The Past Twelve Months

(Continued from page 70)

As regards the latter label, Negram experienced the great come-back by The Everly Brothers, due to a visit they paid to Holland in May. Negram's total turnover of last year was doubled in comparison with the year before. On one side, this is due to the addition of the above mentioned labels and on the other side to the variety of repertoire which was released on the labels, of which Negram had already the representation. Meanwhile the great number of labels which was represented by Negram, made it necessary to enlarge the number of salesmen. Besides which they introduced a new system of representation, which implied that the total repertoire was split in two label groups, so that each of the salesmen bears the responsibility now for half of the total repertoire.

In May Negram was associated with Delta Records N.V. and Delta's director, Hans I. Kellerman, was appointed in Negram's management as commercial manager with the responsibility for the programme choice and for the sales. This implies that Negram's Robert Oeges will get more elbow-room in the future to further strengthen the already pleasant relations which they keep with their licensors abroad. Under his management Negram succeeded in climbing from a modest position to a position in the group of important record companies. Apart from the great number of hits which was released, it is certainly worthwhile to mention among the standard and classical repertoire the success of the Vogue-line Mode. A well aimed advertising campaign was carried on in the beginning of this year with the result that this label, with its wide diversity of repertoire, has become one of the most popular record labels of Holland. In the past year, many artists paid a

promotional visit to Holland, o.a. Francoise Hardy, the Honeycombs, Sandie Shaw, Donovan, The Everly Brothers, Udo Jügens, Rudolf Schock, the Kinks and the Searchers. All those visits resulted in an increased turnover of their respective records, which were released at that time. Because of the great attention paid to the foreign repertoire, the Dutch production, with which Negram had started on a modest scale, did not show to full advantage. An exception to this may certainly be called the fact that the Dutch beat group, the Motions, was already chosen as the most popular group of Holland within a half year after their start. N.V. Delta Records released with great success a N.V. Delta released Dutch cover version of the former Tex Tylor record, "Deck of Cards." The Dutch version was spoken by Radio Veronica deejay Gerard de Vries. This record became such an enormous success in Holland and Belgium, that it reached the second position on the Dutch charts and belonged to the first 10 in Belgium. Translations in German and French were released too, and taken over by Germany, Switzerland, Austria and France.

During the course of the past year, CBS Grammofoonplaten has established itself very well in the Benelux territory. First rate artists, first rate quality and presentation of records and a consistent international promotion service have done a great deal to make the CBS label very popular in Holland, Belgium and Luxembourg. The CBS Benelux production also has done a great deal to make this label well known throughout the low countries, as well as abroad. So far, CBS' local artists include the Kilima Hawaiians, Louis van Dyke, the Pico's, Laguestra, the Down Town Jazz Band, Jacky Delmone, Eddy Christiani and many others.

The first CBS album by the Louis van Dyke Trio rapidly became one of the best-selling jazz LP's in this country and recently was awarded the Dutch Edison for its outstanding pianistic performance. The Kilima Hawaiians' album, entitled "Farewell Hawaii," also being released in the U.S., and the tremendous release of the first CBS album, entitled "Dixieland Festival!" by the Down Town Jazz Band, which already established itself as a blockbuster in this territory. The visits of the CBS artists to the Netherlands have been unforgettable. Among them, in the popular field, were Kenny Rankin, the New Christy Minstrels, the Jacob Sisters, Thelonious Monk, Yves Montand, Maurice Fanon and Jimmy Gilmer, the Pebbles and Fats & His Cats, whereas, in the classical field, Rudolf Serkin, Robert Casadesus, Jean Casadesus, George Szell, the Cleveland Orchestra and Richard Burton impressed the Dutch very much. George Szell & the Cleveland Orchestra has been one of the special highlights at the recent held Holland Festival, and claimed as one of the best orchestras in the world. There have been many highlights, with which CBS Grammofoonplaten played an important role and operated on a large scale. The "My Fair Lady" premiere date of the movie resulted in enormous sales of the CBS Sound Track Recording which continues to sell throughout the low countries, as does "Major Dundee," "Advance To The Rear," "Send Me No Flowers," "Porgy and Bess," "West Side Story," "55 Days at Peking," "The Fall of the Roman Empire," and "Die Grosse Kur" (Marika Kilius & Hans-Jürgen Baümler). Due to the enormous expansion of CBS Grammofoonplaten, during the last period, the company had to increase its Staff, which includes CBS' sales manager Hemmy J. S. Wapperom and as-

sistant sales manager Gerard Hulsebosh, with promotion manager Paul Muller and TV/Artists relation man Frans van Schaik.

The Dutch Barclay company started its activities a year ago. And this has been a successful first year! Two big hits! First the "Jenka" and two months ago the "Sirtaki," based on the original sound track from the film, "Zorba the Greek." Zorba is already high on the hit lists; however, the biggest results are expected in Sept. when the film is going to be released in the larger cities. Also good results with Aznavour, Brel, Ferrat, Leo Ferré and Hugues Aufray were chalked up. At the Grand Gala du Disque in Oct., Ferré will receive an award, the Edison, for his album "Leo Ferré Chante Verlaine et Rimbaud." The big surprise was Erato, the exclusive classical label on the field of baroque music. The interest shown, and the sales, indicate great possibilities for the Barclay company in the year to come.

Artone, with its Haarlem and Brussels-based offices in full swing, is gaining in prominence each year. During the 1964/65 season, the company and its subsidiary, Funcker Records, acquired several new U.S. labels for Benelux distribution, notably Epic, United Artists/DCP, Speciality, Command (for Holland) and Westminster (also for Germany, Austria and Switzerland), as well as Festival (from France), Ricordi (from Italy) and Hansa (from Germany). In the classical field, Artone launched a locally produced line of classical recordings by prominent Dutch artists, of which two albums have been nominated for Edison Awards in the meantime, thereby capping the diskery's 8-year development into a major independent recording industry in Benelux. Jazz-wise, Impulse gained special credit and extra status with two Edison

(Continued on page 74)

COMPLETE NATIONAL REPRESENTATION

IN HOLLAND

N.V. Grammofoonplatenmaatschappij CNR
postbox 5075 - Scheveningen - Holland
OWN PRESSINGPLANT

HOLLAND: MUSIC PUBLISHERS

EDITIONS ALTONA

(Unart Music Holland, Palace Music Holland, Edward Kassner-Benelux, etc.)
Symphony House, Vondelstraat 90, Amsterdam—w
Phones: 186324-186325
Director: W. B. van Vught

ANAGON MUSIC PUBLISHERS N.V.

(Schalltone, Montana International, Morotone, Lions Music Corp., Marange Music, Capriole, Vogue International)
"Melody House," Heemsteedse Dreef 287, Heemstede
Phone: 83654
General Director: Jan van Schalkwijk
Secretary: Miss Joyce Duijthoff
Music Dept.: Henk van Leeuwen
Copyright Dept.: Miss Netty Winkel

ATLANTIC

Waverstraat 78, Amsterdam-Z
Phone: 736104
Managing Director: Chr. Th. Back

LES EDITIONS INTERNATIONALES BASART N.V.

(M.P.H.C., Leeds, Campbell Connelly, Marks, Goodman, Mills, Schroeder, Bourne, Peter Maurice)
Leidsegracht 11, Amsterdam
Phone: 222626
Directors: A. J. G. Strengholt, H. C. Gomperts, Guus Jansen Jr.

BELINDA (AMSTERDAM) N.V.

(Aberbach-Holland, Progressive-Holland, Mix Music, Molen Muziek, Victoria Muziek, Sunrise Muziek)
Leidsegracht 1, Amsterdam
Phone: 220162
Managing Director: Elbert van Zoeren

BENELUX MUSIC

Station, Weert
Phone: 2620
Director: Johnny Hoes

CHAPPELL & CO. HOLLAND N.V.

Weteringschans 35, Amsterdam-C
Phones: 64664-64790

HOLLAND MUSIC N.V.

(Southern Music Publishing Company Ltd., Peer International Corp.)
Singel 500, Amsterdam
Phone: 231163
Director: Han Dunk

IMPALA MUSIC

Huizerweg 13, Blaricum
Phone: 6050
Managing Director: W. J. van Kooten

INTERNATIONALE MUZIEK CO.

(Screen Gems, Acuff-Rose, World Music, etc.)
Sinjeur Semeynsstraat 58, Amsterdam
Phone: 120319
Manager: J. Steenbergen

INTERNATIONALE MUZIEKUITGEVERIJ DE KRUYFF

Rijksstraatweg 115, Gaanderen, Doetinchem
Phone: 4181
Director: J. de Kruyff

MUZIEKUITGAVEN MELODIA/FRANCISDAY MUZIEKUITGEVERS N.V.

Amstel 52, Amsterdam
Phone: 238800
Director: C. Smit Jr.

METRO MUZIEK

Bern. Zweerskade 18, Amsterdam-Z2
Phone: 723116
Managing Director: Mrs. C. A. J. Antoni-Schoonenburg

MUZIEKUITGEVERIJ J. POELTUYN

Deurlostraat 18, Amsterdam
Phone: 722827

MUZIEKUITGEVERIJ JOOP PORTENGEN

(Jean Kluger-Holland, Edition Malando, Boris Music, Publ. Neth. Film Prod. Cy.)
Kruisstraat 8-10, Haarlem
Phone: 12277
Director: Joop Portengen

HOSAT

Suezkade 50, The Hague
Phone: 330998
Director: Mr. Da Silva
Labels: Boite A Musique, Belter, Le Chant Du Monde, Cor, Ennour, Harmonia Mundi, Lieder der Welt, Lumen Lucien Ades, Musique De Tous Les Temps, Musica Sacra, Pacific-Orphee, Pax, Valois, Waverley, Montilla, Zafiro, Iberofon, Charlin, Resonances

INELCO HOLLAND N.V.

Arent Janszoon Ernststraat 801, Amsterdam-Z2
Phone: 421722; Telex: 14622; Cables: Intellect-Amsterdam
Director: W. Brandsteder
Asst. Director: J. F. Mascini
Sales Manager: J. Beutler
Public Relations: A. N. Prins
A & R Manager: C. Koelman
Labels: RCA, Amadeo, Elite

B. MUNNIKENDAM

Kromme Waal 18-19, Amsterdam-C
Phone: 248994
Director: B. Munnikendam
Labels: Acropole, Ansonia, Arc, Blue Note, Collector, Commodore, Electra, Fidelity, Jazz Collector, Lyrique, Mainstream, Monitor, Musidisc, Nonesuch, Period, Presto, Scala, Seeco, Society, Tropical, Typic, Visadisc

N.V. NEGRAM

Zijlweg 286, Haarlem
Phone: 17543
Directors: Rob Oeges & Hans I. Kellerman
Publicity & Promotion: Cees de Man
Program Dept.: Bart Klimmert
Labels: Ariola, Eurodisc, Baccarola, Vogue, Mode, Disc-AZ, Kapp, Congress, Pye, Piccadilly, Negram, Dot, Red Bird, Blue Cat, Elektra, Gene Norman, Peacock, Havoc, Jolly, Reprise, Warner Bros.

N.V. PHONOGRAM VERKOOPMAATSCHAPPIJ VOOR GRAMMOFOONPLATEN

Singel 170-172, Amsterdam
Phone: 245588; Cables: Phonogram-Amsterdam
Managing Director: J. J. M. Haslinghuis
Deputy Director: R. H. Klaassen
Press & Public Relations: Rolf ten Kate
Artists Relations: Jaap Stamer
Administrator: F. Wijngaard
Labels: Philips, Decca, London, Fontana, Mercury, Riverside, Argo, P'Oiseau Lyre, Audio Fidelity, Caedmon, Cygnus

POLYDOR NEDERLAND N.V.

Piet Heinplein 5, The Hague
Phone: 634955; Cables: Polned-Thehague; Telex: 31481
Managing Director: J. H. Buinink
Sales Manager: T. A. van Holten
Purchase Dept.: W. J. Hemerik
Label Manager Classical: Drs. J. van Bart
Label Manager Popular: F. C. Haayen
Labels: Archiv (Germany), Brunswick (USA), Coral (USA), Command (USA), Deutsche Grammophon Gesellschaft (Germany), Heliodor (Germany), M.G.M. (USA), Polydor (Germany), Verve (USA)

M. STIBBE & CO N.V.

Houtmankade 20, Amsterdam
Phone: 241260
Director: F. Basart
Labels: Alpha-Belgium, Discophiles Francaises, Durium, Saba, Savoy, Trianon, Stibbe

HOLLAND: RECORDING STUDIOS

ARTISOUND

Dikninge 117, Amsterdam, phone: 423497 (office); Doelenzaal, Groenburgwal 24, Amsterdam, phone: 66679 (studio)

BAVOHUIS

Sumatrastraat 2, Amsterdam, phone: 740499

N. V. BOVEMA

Overboslaan 6, Heemstede, phone: 80750

GELUIDSTECHNISCH BUREAU GTB

Jan van Nassastraat 67, The Hague, phone: 244555

L. LUDOLPH

P. de Hooghlaan 11, Nw. Loosdrecht, phone: 3744

N. V. PHONOGRAM

Honingstraat 14 A, Hilversum, phone: 14956

BELINDA

(Amsterdam) N.V.

FOR FULL PUSH PUBLISHING!

Leidsegracht 1, Amsterdam, Holland

Full Exploitation
in Holland through

The WORLD MUSIC Organization

Bread and Butter (Acuff Rose)

Clapping Song (Zelgo Mondial)

Draai 7 9 7 2 0 4 (Southern)

Early Bird (Audeo-Video)

Hawaii Tattoo (World Music)

Ik heb mijn hart in Katendrecht

verloren (IMC)

I love you because (Acuff Rose)

La Playa (Top Music)

Paper Tiger (Acuff Rose)

Pretty Women (Acuff Rose)

Si Vedra (Sugar Music)

Contact:

INTERNATIONALE MUZIEK Cie

Mr. and Mrs. Steenbergen

Sinjeur Semeinstraat 58

AMSTERDAM—Holland

Tel. 120319

Our specialities are:

HEAVY PLUGS ON YOUR ORIGINAL RECORDINGS
and

IMPORTANT LOCAL COVER-RECORDINGS

We handle the catalogues of

UNITED ARTISTS MUSIC — New York
SPANKA MUSIC — New York
PLACE & BURLINGTON MUSIC — London
and our Staff is ready to start with your material

EDITIONS ALTONA NV. Symphony House—AMSTERDAM
Vondelstraat 90. General Manager: Wim van Vught
Phones: 18 63 24 & 18 63 25. Cables: ALTONMUSIC

HOLLAND: RECORD MANUFACTURERS

ARTONE GRAMOPHONE N.V.

Kruisstraat 8-10, Haarlem
Phone: 17476; Telex: 41051; Cables: Artone-Haarlem
Presidents: Bill C. Slinger & Casper D. Slinger

Director and Sales Manager: John J. Vis
A & R Manager: Lion J. Svaab
Publicity & Promotion: Paul Visser
Labels: Artone, ABC Paramount, Cameo-Parkway, Command, Festival, Hansa, Hebra, Impulse, Ricordi, Speciality, United Artists, Westminster

BARCLAY NEDERLAND N.V.

Singel 104, Amsterdam
Phone: 234361
Managing Director: B. R. Maassen
Labels: Barclay, Riviera, Erato, Hispavox

BASART GRAMMOFOONPLATENMAATSCHAPPIJ N.V.

Houtmankade 20, Amsterdam
Phone: 222192-63209; Cables: Editoras-Amsterdam
Directors: A. J. G. Strengholt, H. C. Gomperts, F. Basart
Labels: Vox, Christophorus, Europhon, Walt Disney, Leger des Heils, Kniga, Cotta, Delyse, Alpha-England, Camerata, Experience, Anonyme, Folkways, Orchestrola, President, Show Records, Legend

BOVEMA VERKOOPMAATSCHAPPIJ N.V.

Bronsteeweg 49, Heemstede
Phone: 80750
President: G. M. Oord
Chief Programming Office and A & R Manager: John G. Moring
Publicity: Cor Aaftink
Labels: Columbia, Capitol, His Master's Voice, Imperial, Liberty, Pathe, Atlantic, S.M., Stateside, Ember, Delyse, Laurie

CBS GRAMMOFOONPLATEN

Jansstraat 14, Haarlem
Phone: 17476; Telex: 31051; Cables: Col-record-Haarlem
Managing Partners: Bill C. Slinger & Casper D. Slinger
Sales Manager: Hemmy Wapperom

Assistant Sales Manager: Gerard Hulsebosch
Classical Promotion: Paul Muller
Popular Promotion: Frans van Schaik
Advertising: Louk Varossieau
Label: CBS

CNR GRAMMOFOONPLATENMAATSCHAPPIJ N.V.

Gevers Deynootplein 40, Scheveningen (The Hague)
Phone: 559500; Cables: Cener-Den Haag
General Director: C. N. Rood
Director: H. van Zeeland
Label Manager: W. den Daas
Publicity and Promotion: G.v.d. Meent
Planning: G. Boon
Labels: CNR, Telefunken, Ducretet, Thompson, Storyville, Cantate, Harmonia Mundi, Triola, Cetra, Fonit, Karussel, Swe-Disc, Muza, Trans-Atlantic

DELTA GRAMMOFOONPLATEN N.V.

Zijlweg 286, Haarlem
Phone: 17543
Director: Hans I. Kellerman
Labels: Delta, Sonet, Olympia, New Tone, Vergara, Hilltop, Design, Pickwick, Cardinal

N.V. DURECO

Beursstraat 21, Amsterdam
Phone: 242288; Cables: Recmus-Amsterdam
Sales Manager: Ch. P. Noordendorp
Publicity & Public Relations: J. D. Timman
Administration: A. M. Esveld
Labels: Omega, Te Deum, Metronome, Ojee, Telstar, Week-End, Vega

FUNCKLER RECORDS N.V.

Kruisstraat 8-10, Haarlem
Phone: 17476; Telex: 41051; Cables: Artone-Haarlem
Presidents: Bill C. Slinger & Casper D. Slinger
Director: John J. Vis
Sales Manager: Pete Felleman Jr.
Publicity & Promotion: Paul Visser
Labels: Funckler, Apex, Aristocrat (Chess, Checker, Argo), Barenreiter, Colpix, Dimension, Epic, Hickory, Prestige, Palette, Roulette, Tamla-Motown, Tico

BASART

in
BENELUX

NUMBER ONE MUSIC PUBLISHER

LEIDSEGRACHT 11—AMSTERDAM—HOLLAND

Phone: 222626

HOLLAND — The Past Twelve Months

(continued from pg. 72)

Awards for Coleman Hawkins (1964) and Oliver Nelson (1965), marking the label as an important jazz line distributed in Holland. Always active in getting top pop talent from abroad, available for local TV-exposure, Ar-tone managed to organize promotional tours for such artists as the Newbeats (Hickory), the Supremes, Marvin gaye (Tamla-Motown), Chuck Berry, Jacky Ross & Johnny Nash (Aristo-crats) and the Marvelettes (Tamla-Motown), all of whom saw an increase in their local record-sales. The company also expanded considerably into the local pop recording field. Local ace trumpeter Willy Schobben's comeback was brought about, resulting in international sales, whereas top teen-beat combo, Z. Z. & The Masks, besides making a successful 4-week tour of England, was honored with this year's Edison in the Local Teenage Repertory category. Local thrush Margie Ball, elected the vocal find of the year, hit hard with her initial recording sung in English, whilst local productions by Los Tenientes and Willy & The Giants received international acclaim, with the latter group's recordings making chart appearances in Japan, Argentina and Malaysia.

In Oct., pianist Peter Nero and Indian guitar-duo Los Indios Tabajaras were the welcome guests of RCA-In-elco-Holland N.V. They appeared at the Grand Gala du Disque, where they had a tremendous success. The Zagreb Soloists, conducted by Antonio Janigro, have given various concerts in Holland, in Dec. and June, during the Holland Festival. Arthur Fiedler, Arthur Rubinstein and Erich Leins-dorf also paid a visit to Holland. The famous French RCA songster, Alain Barrière, appeared on Dutch TV and acquired a lot of Dutch admirers. The well-known Dutch beat-group, Johnny Kendall and the Heralds, made a very successful tour in Italy. While there, they made some singles and an LP. Chet Atkins, Floyd Cramer and the Anita Kerr Singers paid a visit to

Holland for a TV appearance on Vara. The complete Nashville show, recorded in Oslo on April 1964, with Jim Reeves, who died in a plane-crash several months later, brought on the screen again in June 1965 for NCRV television. A special award has been given to Arthur Rubinstein and Joan Baez, The Edison (comparable with the Grammy award, but the Edison confines itself only to the musical aspects and the recording). Joan Baez, with her famous folk songs and her originality in "Joan Baez Vol. 5," and Arthur Rubinstein with his wonderful recording of French music, fully deserve this award.

HOLLAND: PRESSING PLANTS

ARGRAM PHONOGRAPHIC INDUSTRY
A. P. I.
Kruisstraat 8-10, Haarlem, phone: 17476 (office); Nijverheidsweg 34, Haarlem (factory)

N.V. BOVEMA
Bronsteeweg 49, Heemstede, phone: 80750 (office); Blekersvaartweg 45, Heemstede (factory)

FUGRAM PHONOGRAPHIC INDUSTRY
Noorderduinweg 54, Zandvoort, phone: 4431

PHILLIPS PHONOGRAFISCHE INDUSTRIE
N. V. (P.P.I.)
Gerrit van der Veenlaan 4, Baarn, phone: 3551 (office); Torenlaan, Baarn (factory)

N.V. TELCAP
Vort van der Lindenstraat 11-13, Rijswijk (ZH), phone: 985153

HOLLAND: MATRIXES FACTORIES

ARMETAL GALVANIC INDUSTRY
Kruisstraat 8-10, Haarlem, phone: 17476

N.V. BOVEMA
Blekersvaartweg 45, Heemstede, phone: 80750

PHILIPS PHONOGRAFISCHE INDUSTRIE
N. V. (P.P.I.)
G.v.d. Veenlaan 4, Baarn, phone: 3551

N.V. TELCAP
Cort van der Lindenstraat 11-13, Rijswijk (ZH), phone: 985153

HOLLAND: POLL RESULTS 1964

(Through the Courtesy of Dutch Monthly "Muziek Expres")

FOREIGN ARTISTS

Top Female Singer	Per Cent
1. CILLA BLACK	22.2
2. Francoise Hardy	20.2
3. Dusty Springfield	13.6
4. Connie Francis	12.0
5. Brenda Lee	5.2

Top Male Singer	Per Cent
1. CLIFF RICHARD	39.2
2. Adamo	17.8
3. Elvis Presley	16.0
4. Roy Orbison	6.8
5. Jim Reeves	1.9

Top Vocal Group	Per Cent
1. BEATLES	48.9
2. Rolling Stones	13.1
3. Shadows	11.8
4. Les Surfs	5.3
5. Dave Clark Five	3.2

Top Big Band	Per Cent
1. NORRIE PARAMOUR	22.7
2. Billy Vaughn	15.9
3. Werner Muller	15.5
4. Mitch Miller	7.1
5. Mantovani	6.0

Top Small Combo	Per Cent
1. SHADOWS	63.4
2. Beatles	6.8
3. Dave Brubeck	5.9
4. Spotnicks	5.6
5. Rolling Stones	3.6

Top Jazz Band	Per Cent
1. DAVE BRUBECK	46.8
2. Mr. Acker Bilk	11.6
3. Kenny Ball and his Jazzmen	10.2
4. Chris Barber	5.9
5. Duke Ellington	3.8

Top Radio Program	Per Cent
1. TOP TWENTY (LUX.)	19.8
2. Caroline (general)	13.0
3. Top Fifty (Caroline)	9.1
4. Pick of the Pops (BBC)	7.8
5. Luxembourg (general)	5.3

Top T.V. Program	Per Cent
1. BONANZA	30.0
2. Dick van Dyke Show	22.1
3. Beverly Hillbillies	5.3
4. Rawhide	4.9
5. Musik aus Studio B	4.7

Top Disc Jockey	Per Cent
1. CHRIS HOWLAND	21.4
2. Barry Aldis	19.6
3. Alan Freeman	8.7
4. Jimmy Savile	8.4
5. Tony Blackburn	5.2

Top Record 1964	Per Cent
1. IT'S BEEN A HARD DAYS NIGHT (Beatles)	11.7
2. On The Beach (Cliff Richard)	11.5
3. Vous Permettez, Monsieur (Adamo)	9.8
4. Constantly (Cliff Richard)	7.1
5. Such A Night (Elvis Presley)	5.8

DUTCH ARTISTS

Top Female Singer	Per Cent
1. WILLEKE ALBERTI	35.6
2. Trea Dobbs	29.4
3. Shirley Zwerus	10.0
4. Anneke Grönloh	8.0
5. Imca Marina	3.5

Top Male Singer	Per Cent
1. ROB DE NIJS	43.3
2. Johnny Lion	35.5
3. Johnny Kendall	3.6
4. John Lamers	2.6
5. Gert Timmerman	2.3

Top Vocal Group	Per Cent
1. BLUE DIAMONDS	20.2
2. Z.Z. en de Maskers	19.7
3. Johnny Kendall & The Heralds	16.3
4. Cocktail Trio	13.1
5. Fouryo's	13.0

Top Big Band	Per Cent
1. VARA-DANSORKEST	29.2
2. Malando	15.8
3. De Zaalers	10.3
4. Metropole Orkest	10.2
5. Skymasters	7.1

Top Small Combo	Per Cent
1. THE JUMPING JEWELS	55.9
2. Trio Pim Jacobs	11.9
3. Z.Z. en de Maskers	7.9
4. The Lords	6.0
5. The Torero's	2.6

Top Jazz Band	Per Cent
1. DUTCH SWING COLLEGE BAND	66.9
2. Trio Pim Jacobs	21.6
3. New Orleans Syncopators	6.5
4. Down Town Jazzband	1.1
5. 21 various bands	3.9

Top Radio Program	Per Cent
1. TIJD VOOR TEENAGERS (VARA)	27.3
2. Teenager Muziek Expres (Veronica)	22.8
3. Joost mag het weten (Veronica)	14.8
4. Tussen 10+ en 20- (AVRO)	9.8
5. Cliff Richard Show (Veronica)	5.4

Top T.V. Program	Per Cent
1. TOP OF FLOP (VARA)	54.7
2. Rudi Carell Show (VARA)	12.0
3. Rooster (AVRO)	8.7
4. Stiefbeen & Zn. (NCRV)	3.8
5. Combo (AVRO)	3.0

Top Disc Jockey	Per Cent
1. JOOST DE DRAAIER (Veronica)	46.4
2. Herman Stok (VARA)	27.6
3. Jos Brink (AVRO)	14.8
4. Cees van Zijtveld (Veronica)	4.5
5. Bob en Brenda (Veronica)	1.4

Top Song 1964	Per Cent
1. DE WINTER WAS LANG (Willeke Alberti)	32.1
2. Spiegelbeeld (Willeke Alberti)	12.7
3. Wit satijn (Rob de Nijs)	8.5
4. La mamma (Corrie Brokken)	7.1
5. Loop naar de maan (Rob de Nijs)	5.2

neGram

Still breaking through the charts



N.V. NEGRAM HOLLAND

ZYLWEG 286 HAARLEM

reprise

Dot RECORDS

PE

vogue

KAPP

WB

Arvola

MGM



RECORDS

MGM / VERVE STARS BELONG TO THE WORLD
CONNIE FRANCIS ■ ROY ORBISON ■ HANK
WILLIAMS, JR. ■ JOHNNY TILLOTSON ■ SAM THE
SHAM AND THE PHARAONS ■ RICHARD CHAMBERLAIN
STAN GETZ ■ ASTRUD GILBERTO ■ CAL TJADER
LALO SCHIFRIN ■ JIMMY SMITH ■ COUNT BASIE



MGM and Verve Records are divisions of Metro-Goldwyn-Mayer, Inc.

BELGIUM—The Past 12 Months

Anvers Radio

has a big trump of course with the regular sales of Impulse LP's, a label very much in favour among Belgian jazz-fans. Two young children, Karine and Rebecca helped them to a quite successful hit "Moi je dors avec nounours dans mes bras" (I sleep with my bear-bear in my arms). Recordings made by Ronny, Fats Domino and Ray Charles also enjoyed very good sales. This company has plenty of initiative, as was proved by the production of an LP of marching music, which has become an international success.

Artone

too is doing well. Its biggest sales are undoubtedly racked up by "The Supremes". The public relations man, Willy Delabastita, saw to it that as many stars as possible appearing on the label, got on radio and TV during the past year. And quite successful he was too. Generally this initiative originates with Peter Felleman Jr. of the main headquarters in the Netherlands. On the whole a business year with more than satisfactory sales figures.

Barclay

can look back on a really fruitful year. In the past few months sales of the EP from the soundtrack of the movie "Zorba the Greek" has been exceptionally good. Aznavour, Eddy Mitchell, Jacques Brel and also Charles Trenet are in Belgium, as well as in France, a pretty safe bet on the record-market. The progress noted in the sales of albums is remarkable.

Cardinal

is a newcomer among the recording companies. Owned by the internationally famous singer Rocco Granata and managed by the former Moonglow sales-manager Willy Vander Steen, this firm, established at Antwerp, took off almost like a rocket. From small beginnings it could very well in the future become one of the major companies in the country.

CBS

has a prosperous year behind it. Its best seller is beyond a doubt Bobby Solo. His disks sold like hot cakes. This company did not content itself with putting on the market mainly original American productions, but under the impetus of its artistic director Jean Kluger it has started its own local production. Here too closer contacts are sought with journalists of radio, TV and press.

Discobel

launched a rather startling innovation: EP's with recordings of the warbling of many different birds. And judging from the reception by the public, very much appreciated. Good sales are registered too of their Ariola-reportory, as well as singles of Red Sheldon and Ricky Morvan, two local discoveries of music publisher Werner Huys.

Discotrade

did pretty good with singles of Guy Béart, Marie Laforet, Les Surfs, M. Delpech, Zina. This company during the past year organized several press-receptions at which it presented its artists. Important too now is the marketing of some Greek recordings.

Fonior

did also very well. Its discovery is Claudia Silva, the girl who scored a bull's eye with her first Decca record "J'ai pleuré" (I cried). Another important discovery is the Duo Acropolis, whose rendition of the theme song of the movie "Zorba the Greek" became a hit. Business was excellent with recordings by Lucille Star, The Rolling Stones, Roy Orbison, and others. The company did praiseworthy efforts to bring artists over here for appearances on radio and TV, and public performances.

Gramophone

can look back on a magnificent year. While sales of Adamo records stayed

at a very high level in Belgium, just as the previous year, the breakthrough of Adamo in France is of considerable significance for the company. The Beatles-disks raked up better sales than the preceding year. Cliff Richard, The Shadows, Richard Anothony, The Animals and others, remain of course, as always, hit-makers.

Inelco

can boast fine sales of the Alain Barrière songs, which already last year, starting with the hit "Ma vie" (My Life), were in great demand. Elvi-records seem to be enjoying a renewal of interest. Sales manager Willy Roelandts was instrumental in bringing a great number of RCA stars over to Brussels for a TV-show. Demand for LP's was good too.

Philips

enjoyed a considerable success, especially with the French production, with of course French artists. Locally too the firm put in some hard work and notable is the discovery of the Flemish singer Liliane. Manager Lebbinck is quite satisfied about business during the past year. It carried out a thorough job of contacting the Belgian press. The promotion department did a splendid job, really. In due time more attention will be paid to a local Flemish repertory.

Polydor

has certainly no cause of complaint. It stood its ground very well not only with French speaking and American numbers, but through the efforts of the A & R Manager M. Mertens it succeeded in being again at the top with successful Flemish production. Manager Walter Holzappel is particularly happy about the continued business success of his top-classical label "Deutsche Gramophon Gesellschaft" and also his hits on MGM. Sales of LP's were especially rewarding.

Sobedi

once more distinguished itself by offering many youngsters a chance. Many singers and groups, who often in the past were given an opportunity by this company to show their talents, later turned out to be top-flight artists. From time to time a surprise is therefore to be expected on the Olympia—or New Tone label. Always remarkable is the perfect-quality of the recordings made by this firm, something which is of the highest importance for a singer at the start of his career.

Show

as during the previous year, again distributed many records of foreign labels. A considerable effort nevertheless went into local production. Tony Geys, Clark Richard, Anne Fond'roy, Maurice Dean, The Pick-Nicks are some of the names of the Belgian stars for whom Show records did a fine promotion job. It also invited foreign stars and, worth mentioning in this respect, was the promotion campaign for the visit of the Italian star Iva Zanicchi.

Ronnex

was not particularly active this year. Important changes occurred among the personnel. Manager Albert Van Hoogten gave prominence to three stars: Willy Williams, Flemish singer of Flemish and English hit-tunes, les Têtes Blanches, Canadian beatgroup and The Shake-Spears. In the future the firm will emphasize more independent production.

Vogue

has enjoyed in every respect, a successful year. No week went by without at least one or other Vogue-disk getting into the news. Manager Roger Meylemans explained it as follows: "We have had nothing but hit tunes this year and hope to do just as well in the future." . . . As distributors of Pye and Reprise—among others—it did a fine job and succeeded thanks to a thorough promotion campaign to introduce many British hits on the Belgian market.

<p>INTERNATIONAL SERVICE Check the class of service desired; otherwise the message will be sent at the full rate.</p> <p>FULL RATE <input type="checkbox"/></p> <p>LETTER TELEGRAM <input checked="" type="checkbox"/></p> <p>SHORE-SHIP <input type="checkbox"/></p> <p>TIME FILED</p>	<p>WESTERN UNION TELEGRAM</p> <p>W. P. MARSHALL, PRESIDENT</p> <p>CHARGE TO THE ACCOUNT OF</p> <p>TELEGRAM NO. <u> </u></p> <p>CASH NO. <u> </u></p> <p>PD. OR COLL. <u> </u></p> <p>NO. WDS. CL. OF SVC. <u> </u></p> <p>DAY LETTER <u> </u></p> <p>NIGHT LETTER <u> </u></p> <p>Send the following message, subject to the terms on back hereof, which are hereby agreed to</p>
--	--

VIA...Belgian Representative... Indications De Service

ADDRESSE.....To ALL CASH BOX-Readers in

USA - EUROPE - AFRICA - AUSTRALIA - SOUTH AMERICA

PETER PLUM PUBLICATIONS IS A FIRM DESCRIBED BY ONE

WORD "ACTION" STOP CONTACT US IMMEDIATELY STOP

P.P.P. 18, rue des Teinturiers, BRUSSELS 1 STOP

PHONES 11.52.29. and 11.47.43. STOP CABLE: PLUMUSIC STOP

OUR GUARANTEES: ACTUAL RESULTS AND STATEMENT\$ STOP

PETER PLUM
Belgium



We record
We manufacture
We print
We sell
We publish

Sobedi
Sobedi
Sobedi
Cobedi
Fonogram

We can lease masters for your country. We have available: accordion, organ, jazz, classical, vocal (English, French, Spanish etc. . . .). South American, instrumental. . . . We can supply you with actual international hits or with new releases. Many of our recordings can be given in sub-publishing for your area.

We can use new material—Send us your samples or tapes

For information or samples write to

SOBEDI

20 Bd M. Lemonnier
Brussels
BELGIUM
Phone: 13 13 07

THE LEONARD HODES GROUP

Spectorious Music Corp.
(BMI)

Concertone Songs Inc.

(ASCAP)

161 W. 54th Street
New York 19, N.Y.
(212) JUdson 6-0923

Cable Address:

LENHODES, NEWYORK

AFTER

AUGUST 31st, 1965

MOVING TO NEW

AND

BIGGER OFFICES

1780 BROADWAY,
NEW YORK 19, N.Y.

Representing in the
USA & CANADA:

BLUE BLOOD
MUSIC CORP.

PARTITA
MUSIC CORP.

ROSE HILL
MUSIC CORP.

On the Charts in the
USA this year with such
great artists as:

The Beatles
Adam Faith
Sandie Shaw
Gerry & The
Pacemakers
The Honeycombs
Marianne
Faithfull

Coming soon our
own label for
International and
American masters.
TCF (IMPORT).

America's
leading publisher of
International Music.

LEONARD HODES
President

JOE MIYASAKI

Dir. of
Far East Relations

BESTSELLERS PAST 12 MONTHS

Walloon

1. N'Avoue Jamais (Guy Mardel/Vogue/Primavera)
2. Letkis (Several versions/Peter Plum)
3. Ma Vie (Alain Barriere/RCA/Primavera)
4. Ma Pipe (Henri Salvador/Vogue/Vogue International)
5. Vous-permettez, Monsieur? (Adamo/Pathe/Ardmore and Beechwood)
6. Zorba le Grec (Mikis Theodorakis/Barclay-Duo Acropolis/Decca)
7. Que C'est Triste Venise (Charles Aznavour/Barclay/Peter Plum)
8. Oh, Pretty Woman (Roy Orbison/London/Acuff-Rose)
9. Le Penitencier (Johnny Halliday/Philips/World)
10. La Mamma (Charles Aznavour/Barclay/Peter Plum)
11. Dolce Paola (Adamo/Pathe/Ardmore and Beechwood)
12. Les Filles du Bord de Mer (Adamo/Pathe/Ardmore and Beechwood)
13. Toujours un Coin Qui me Rapelle (Eddy Mitchell/Barclay)
14. Poupee de Cire, Poupee de Son (France Gall/Philips/Moderny)
15. La Nuit (Adamo/Pathe/Ardmore and Beechwood)
16. Une Biere Pour Mon Cheval (Robert Cogoi/Philips/World)
17. Se Pianzi, se Ridi (Bobby Solo/CBS/Belga)
18. Katy (Marc Aryan/Markal/Moderny)
19. Le Chef de la Bande (Frank Alamo/Riviera/Brauer)
20. Va-t en, Va-t en (Dick Rivers/Pathe/Belinda)
21. Les Choses de la Maison (Claude Francois/Philips/Belinda)
22. Moi je Dors Avec Nounours Dans Mes BRAs (Karinne et Rebecca/Hebra/Brauer)
23. Tell Me (The Rolling Stones/Decca/Southern)
24. Elle (Adamo/Pathe/Ardmore and Beechwood)
25. J'y Pense Et Puis J'Oublie (Claude Francois/Philips/Belgalux)
26. Les Cloches Sonnaient (Richard Anthony/Columbia)
27. Je Me Suis Souvent Demande (Richard/Columbia)
28. Vous Les Copains (Sheila/Philips)
29. Rock 'n Roll Music (The Beatles/Parlophone)

BESTSELLERS PAST 12 MONTHS

Flemish

1. N'Avoue Jamais (Guy Mardel/Vogue/Primavera)
2. Ma Vie (Alain Barriere/RCA/Primavera)
3. Letkis (Several Versions/Peter Plum)
4. Oh Pretty Woman (Roy Orbison/Fonior/Acuff-Rose)
5. Draai 79 72 04 (Will Tura/Palette/World)
6. Dolce Paola (Adamo/Pathe/Ardmore and Beechwood)
7. Ma Pipe (Henri Salvador/Vogue/Vogue International)
8. Ik Zie In Je Ogen (Larry/Polydor/Passepartout)
9. Que C'est Triste Venise (Charles Aznavour/Barclay/Peter Plum)
10. La Nuit (Adamo/Pathe/Ardmore and Beechwood)
11. Poupee de Cire, Poupee de Son (France Gall/Philips/Moderny)
12. The House Of The Rising Sun (The Animals/Gramophone/World)
13. Zorba The Greek (Mikis Theodorakis/Barclay-Duo Acropolis/Decca)
14. Se Pianzi, se Ridi (Bobby Solo/CBS/Belga)
15. Tell Me (The Rolling Stones/Decca/Southern)
16. Waarom (John Larry/Polydor/Passe Partout)
17. Waarom (Liliane/Philips)
18. You're So Simpatico (Ray Mondo/Cardinal/World)
19. Rock 'n Roll Music (The Beatles/Parlophone)
20. Katy (Marc Aryan/Markal/Moderny)
21. Crazy Lover (Red Sheldon/Discostar/Disco Music)
22. The Birds And The Bees (Jewel Akens/London/Peter Plum)
23. Ain't Loving You Baby (Elvis Presley/RCA/Belinda)
24. Mother in Law (Tetes Blanches/Ronnex/Globe)
25. Goodnight (Roy Orbison/London/World)
26. Do The Clam (Elvis Presley/RCA/Belinda)
27. Amore Scusami (John Foster/Show/Moderny)
28. Moi e Dors Avec Nounours Dans Mes Bras (Rebecca et Karine/Arsa/Brauer)
29. J'ai Pleure (Claudia Silva/Decca/Fonior)

BELGIAN RECORDING STUDIOS

S.A. GRAMOPHONE

Quai des Charbonnages, 72, Brussels 8, phone
274390.
Managing director: John Kirsch.
Music director: Yeff de Boeck.

SOBEDI

Boulevard Maurice Lemonnier, 20, Brussels 1,
phone 131307-131306.
Managing director: Fernand Janssens.

PALETTE

rue de la Madeleine, 13, Brussels 1, phone
115120.
Managing director: Roland Kluger.

FONIOR

Quai des Charbonnages, 26, Brussels 8, phone
254010 and 270801.
Smaller one (also Fonior): Chaussée de Jette,
Brussels 8, phone 263363.
Managing director: Pelgrims de Bigard and
Achille Palmans.

RCA-STUDIO

rue de l'Hopital, 20-24, Brussels 1, phone
112220.
Managing director: J. P. Yoemare.
Music director: Yvon de Bie.

SERVING THE INTERNATIONAL MUSIC BUSINESS

FASTEST RECORD DELIVERY THROUGHOUT THE WORLD BY AIR MAIL
COMPLETE LINE OF ALL AMERICAN LABELS

ALL NEW RELEASES

AIRDISC U.S.A.

SINGLES • ALBUMS

Every quantity shipped. Prices
on request.

Box 545, Radio City Station
New York, N. Y. 10019

Payments by bank draft or In-
ternational Money Order or on
account.

LOOKING FOR ACTION?

LET US PUBLISH YOUR MUSIC!!!

DISCO - MUSIC

Yperstraat, 118

BISSEGEM/Belgium

Tel: 056/2.33.54

THE FASTEST GROWING
MUSIC PUBLISHING COMPANY IN
BELGIUM!

Recent

PALETTE

World Wide
Recordings

Released in the
U.S.A. & Canada
through Kapp—4 Corners

THE WAIKIKIS

HAWAII HONEYMOON

DIGNO GARCIA

y sus Carios



La Playa

LOS MAYAS

LA PLAYA

KYRIAKOS

and his orchestra

ZORBA THE GREEK

ANDRE BRASSEUR

and his Multisound Organ



Early Bird

in
Benelux

Through "Artone"
WILL TURA



Het verleden is
weer dichtbij Het
meisje in't blauw

ARIANE

et les 10/20

Deja l'ete

Questions?



LUIGI



Après tant
d'annees Tu
aurais du



Palette Records Int'l Corp.
250 West 57th St.
New York (19)
Phone JU. 6-3087

BELGIAN RECORD COMPANIES

For full Exploitation in Belgium and Benelux

The WORLD MUSIC Organization

Bread and Butter (Acuff Rose)	Is It True (Peter Maurice)
Can't You Hear My Heartbeat (Southern)	I Stay By You (Sparta)
Catch the Wind (Southern)	J'y Pense Et Puis J'Oublie
Golinda (Southern)	La Playa
Dis-Moi Quand? (Tell Me When) (Southern)	La Tendresse (Southern)
Do Re Mi (Southern)	Maria Elena (Southern)
Draai 7 9 7 2 0 4 (Southern)	Paper Tiger (Acuff Rose)
Early Bird (Audeo)	Pretty Woman
Ferme Du Bonheur (Semi)	Si Vedra
Hawaii Tattoo (World Music)	Tobacco Road (Southern)
House Of The Rising Sun (Le Penitencier) (Peter Maurice)	The Wedding (Peter Maurice)
I Love You Because (Je T'aime Plus Fort) (Acuff Rose)	Une Biere Pour Mon Chevals
	You're Nobody Till Somebody Loves You
	You're So Simpatico

WORLD MUSIC Co. — and Associates

13, Madeleine — Brussels 1

EDITIONS BENS

90. rue Gallait.

Brussels 3

phone: 41.22.80-41.22.87

PRESENTS:



ANVERS RADIO S.A.
Place de l'Yser, 10, Brussels 1, phone 18.74.00-18.74.08 and 09.
Director: W. Goldschmidt.
Sales Manager: A. Janty.
Labels: Telefunken, A.B.C.—Paramount, Duret Thomson, Ricordi, Period, Command, Concert Colomme, Ember, Grand Award, Elite, Whitehall, Candid, Impulse, Valais, Tangering, Telestar, etc.

ARTONE
rue Joseph II, 142, Brussels, phone: 352074 and 73.
Managing director: Mrs. P. Robiefroid.
Publicity and Press: W. Delabastita.
Labels: Palette, Versailles, Funckler, (Hickory, Chess, Checker, Argo, Tuff, Bella Musica, Amulette, Carina), Cameo, Parkway, etc.

BARCLAY
rue du Lombard, 31, Brussels 1, phone: 11.81.97.
Managing director: Mr. Bral.
A&R manager: Peter Plum.
Press and Publicity: Mrs. Plum.
Labels: Barclay, Hispa Vox, United Artists, 20th Century Fox

C. B. S.
Centre International Rogier, 309-311, Brussels 1, phone 187502.
Managing director: Pascal Robiefroid.
Press and Publicity: Miss Mimi Smith.
Labels: CBS.

DISCOBEL S.A.
rue du Lombard, 31, Brussels, phone 13.39.45.
Directors: Paul van de Walle, mme. F. Penninck.
Labels: Atlantic, Roulette, Artydor, Pacific, Storyville, Erato, Ariola, Studio SM, Delahay, Discostar, Prestige.

DISCOLIVRET S.A.
4a, Quai du Commerce, Brussels, phone 17.7678.
Managing director: Mrs. Ginsburg.
Labels: Supraphon, Lumen, Jericho, Ades.

DISCOTRADE
88, rue Gallait, Brussels 1, 161640.
Managing director: Mr. Braunstein.
A&R manager: Mr. Poulet.
Labels: Victory, Festival, Fonit, Tono, Music, Rondo.

FONIOR S.A.
Quai des Charbonnages, 26-28, Brussels, phone 254010.
Directors: E. W. Pelgrims de Bigard, A. de Reuck.
A&R manager: A. E. Palmans.
Labels: Decca, Cetra, Cid, Fiesta, Maestro, Omega, Stella, Surboum, Audio Fidelity, Saga, Vega, Telstar, Week-end, etc.

GRAMOPHONE S.A.
Quai des Charbonnages, 72, Brussels 8, phone 27.43.90.
President: Mr. John Kirsch.
Commercial manager: Mr. Garin.
A&R manager: Jeff De Boeck.
Labels: His Masters Voice, Pathe, Columbia, Fonit, Parlophone, Capitol, Odeon, Gloria, Stateside, Imperial, Liberty, Epic, Encore, Angel, Garrett, Charlin, Bartok, Pathe, etc.

HEBRA
rue St.—Christophe, 30, Brussels 1, phone 129375-127361.
Managing director: Jean Darlier.
Labels: NMC, Mire, Meteor, Carisch, Hebra, Blue Jeans, Milerno.

INELCO BELGIUM S.A.
rue de l'Hopital, 20-24, Brussels 1, phone 112220.
Managing director: Jean-Pierre Goemare.
A&R manager: Ivon de Bie.
Sales manager: Willy Roelants.
Labels: RCA, Camden, Amadeo.

PALETTE
rue de la Madeleine, 13, Brussels 1, phone 11.51.20.
Directors: Fr. Faecq, R. Kluger.
A&R manager: Roland Kluger.
Public relations: Mr. Robby and Mr. P. Meyer.

PHILIPS
rue d'Anderlecht, 37, Brussels 1, phone 134444-134440.
Managing director: P. J. Lebbinck.
Labels: Philips, Fontana, Mercury, Riverside, (Jazzland, Contemporary, Bluesville, Moodville).

SHOW RECORDS
Steenweg op Diest, 69, Aarschot (Brabant), phone 016/66.999
President and general manager: Jules Nijs.
Managing Director: Alain Lelievre.
Labels: Show, Sonet, Canadian American, CGD Internationale, Delta, Italdisc, Josie, Jubilee, Kent, Load Stone, Music Hall, N.O.B., Oriole, Port, Puppy, Ric, Swing, USA, Viking, Ring, etc.

RONNEX
rue de Flandre, 179, Brussels, phone 177989-177982.
Managing director: Albert Van Hoogten.
Labels: Ronnex, Teeny, Fly, Combo, Disco-phon, W&G records, Tempo, Osca, Embassy, etc.

SCHOTT FRERES
rue Saint-Jean, 30, Brussels 1, phone 112122.
Managing director: J. J. Junne.
Labels: Angelicum, Baronet, Christophorus, Commodore, Crown, Club National du Disque, Directional Sound, Eterna, Folkways, Harmonia, Mundi, Jazztone, Blue Note, Montilla, Monitor, Musicaphon Barenreiter, MMO, Period, Savoy, Urania, Time record, Concert Disc.

POLYDOR
116, Chaussee de Charleroi, Brussels 6, phone 373100.
Managing director: Mr. Holtzapfel.
A&R manager: Mr. Mertens.
Labels: Polydor, Brunswick, Coral, Heliodor, Deutsche Gramofon Gesellschaft, Archiv, Metro Goldwyn Mayer.

SOBEDI
20, boulevard Maurice Lemonnier, Brussels 1, phone 131306-131307.
President: Fernand Janssens.
Executive manager: Georges Martens.
Labels: Olympia, New Tone.

SONOBEL
rue Rouppe, 4, Brussels, phone, 120928.
Managing director: Mr. Borzee.
Labels: Vox, Chant du Monde, Pastorale.

AGENCE TODTENHAUPT
122, rue Saint Denis, Brussels, phone: 430050.
Managing director: Mr. Todtenhaupt.
Labels: Teppaz.

VOGUE S.A.
Boulevard Barthelemy, 35, Brussels, phone 117991-117973.
Managing director: Roger Meylemans.
General manager: Leon Cabat.
Public relations: Mrs. Gigi Bastin.
Labels: Vogue, Pop, Pye, Durium, Warner Bros., Contrepoint, Mode, Piccadilly, Reprise, Mode, etc.

WILL
41, Boulevard de l'Abattoir, Brussels 1, phone: 110252.
Managing director: A. Pletinck.
Labels: Will, Teenager.

RONNEX Records

Director: Albert Van Hoogten

179, rue de Flandre—Brussels: Phones: 02/17 79 89 and 20/17 79 82

Is proud to announce to you that we possess the records of two internationally known beatgroups

LES TETES BLANCHES (The White Heads)

and

THE SHAKE-SPEARS,

North-Rhodesian sextet with a world wide reputation

Music Publishers

*To obtain outstanding results in Benelux inquire at

GLOBE MUSIC

A. Van Hoogten—Director

179, rue de Flandre—Brussels: Phones: 02/17 79 89 and 20/17 79 82

BELGIAN MUSIC PUBLISHERS

PUBLI-SHOW
Volksverheffingstraat, 100
AALST
Phone: 053/28576

Belgium

is the fastest growing artist
agency in Belgium!

Have a look to the Belgian
hit parade: John Larry and
Liliane are always in the list
of bestsellers!

Watch for their international
popularity!

Managers overseas:
contact us for the best
results with your
artists in Belgium!

ARDMORE AND BEECHWOOD
Quai des Charbonnages, 72, Brussels 8, phone
274390.
Managing director Belgium: Jeff De Boeck.

EDITIONS CHARLES BENS
rue Gallait, 90, Brussels, phone 412280.
Managing director: Mrs. J. Bosmans.

EDITIONS HERMAN BRAUER
rue St.—Christophe, 30 Brussels, phone 129375-
127361.
Managing directors: Mrs. Brauer and Jean
Darlier.

BELGA MUSIC
Steenweg op Diest, 69, Aarschot (Brabant),
phone 016/66999.
Managing director: Jules Nijs.

DISCO MUSIC
Ieperstraat, 118, Bissegem (Kortrijk), phone
056/23354
Managing director: Werner Huys.

IDEAL MUSIC
Cederlaan, 48, Wilrijk (Antwerp), phone
03/382309.
Managing director: Jean Van Horn.

CLASS MUSIC
Goudbloemstraat, 17, Antwerp, phone
03/329990-329999.
Managing director: R. J. Van Hoogten.
General Manager: Joseph Van Hoogten.

PASSE-PARTOUT-DANCING
Vroenhofstraat, 13, Deurne-Antwerp, phone
03/396320.
Managing director: M. Lambrechts.
Executive Manager: Frank Hermans.

EDITION FONIOR
Quai des Charbonnages, 26, Brussels 8, phone
254010.
Managing director: E. W. Pelgrims de Bigard.
Music director: Achille Palmans.

FONOGRAM
Boulevard Maurice Lemonnier, 20, Brussel 1,
phone 131306-131307.
Managing director: Fernand Janssens.

FRANKIE MUSIC
Greinstraat, 74, Antwerp, phone 03/322485.
Managing director: Jean Meeussen.

GLOBE MUSIC
Vlaamse Steenweg, 179, Brussels 1, phone
177989-177982.
Managing director: A. Van Hoogten.

MODERNY
97, rue de la Marlière, Mouscron, phone
056/31539.
Managing director: Marcel de Keukeleire
(Moderny-Coda-Celtic).

PETER PLUM PUBLICATIONS
rue des Teinturiers, 18, Brussels 1, phone
115229-114743.
Managing director: Peter Plum.

SAB MUSIC
41, Boulevard de l'Abattoir, Brussels 1, phone
110252.
Managing director: A. Pletinck.

PRIMAVERA
Boulevard M. Lemonnier, 1, Brussels, phone
133789.
Managing director: Lamy Vanden Hout.

SCHOTT FRERES
rue saint-Jean, 30, Brussels, phone 112122.
Managing director: J. J. Junne.

EDITIONS TEMPO
rue du Lombard, 60, Brussels.
Managing director: M. van Elewijck.

INTERVOX MUSIC
Boomsesteenweg, 376, Wilrijk-Antwerp, phone
03/388600.
Managing director: L. J. Van Rymenant.

JEAN KLUGER MUSIC
Galerie du Centre, Bloc 3, App. 339, Brussels
1, phone 129238.
Director: Jean Kluger.

WORLD MUSIC—SOUTHERN MUSIC
rue de la Madeleine, 13, Brussels 1, phone
115120.
Managing directors: J. Faek and Roland
Kluger.

Editions

**JEAN
KLUGER**

Galleries du Centre,
Bloc 3, App. 339

Brussels 1.

Phone: 12 92 38

GRANATA MUSIC
Collegelaan, 108, Deurne-Antwerp, phone
03/365646.
Managing director: Rocco Granata.

GOLD CROWN MUSIC
26, Avenue des Buissonnets, Brussels 2, phone
787416.
Managing director: Roger D. Feinberg.

SILVER STAR:
Terdonk, Ghent, phone 09/518950.
Managing director: F. Boone.

ANVERS RADIO

Place de l'Yser, 10

Brussel 1,

Phone: 18 74 00

is one of the Belgians
leading record-distributing-
companies with active people
in their Service.
We distribute exclusively
important labels as:

ABC-Paramount
Telefunken
Elite
Impulse
Ducretet-Thomson
Ember
Arsa
Hebra

SHOW RECORDS means

aggressive,

effective and

enthusiastic

distribution and promotion!

We are always interested in taking over foreign labels and
tapes. Trust your representation for BENELUX to SHOW
RECORDS, Belgium's youngest but most active Record
Company.

Contact us now if you want MAXIMUM sales in the
BENELUX-market!

Phone, wire or write:

SHOW RECORDS

Jules NIJS, Steenweg op Diest, 69, AARSCHOT—BELGIUM
Phone: 01666999



ALSO, FOR BIG RESULTS, CONTACT
OUR PUBLISHING COMPANY

BELGA MUSIC

Jules NIJS
Steenweg op Diest, 69
AARSCHOT—BELGIUM
Phone: 01666999

Foreign personal managers
Artists agencies
Impresarios:

Contact in Belgium

FERNAND DELCUVE
for best results of your artist
in Belgium.

He is the personal manager of

LUIGI

who will be a big international
star in one year! No doubt!

Fernand Delcuve
13, rue Andre Baillon
Brussels 19—Phone: 02/44 06 37



Publishing Company

PASSE-PARTOUT & DANCING

Heist-op-den-Berg / BELGIUM
Representative Frank Hermans
Vroenhofstraat, 13, Deurne-Antwerp
Phone: 03/39.63.20

**With JOHN LARRY—LYDIA—
THE SPOETNIKS—EDDY SUYS**
in the Hit Parade with the regularity of a watch!

Please contact us for the best results in Belgium!

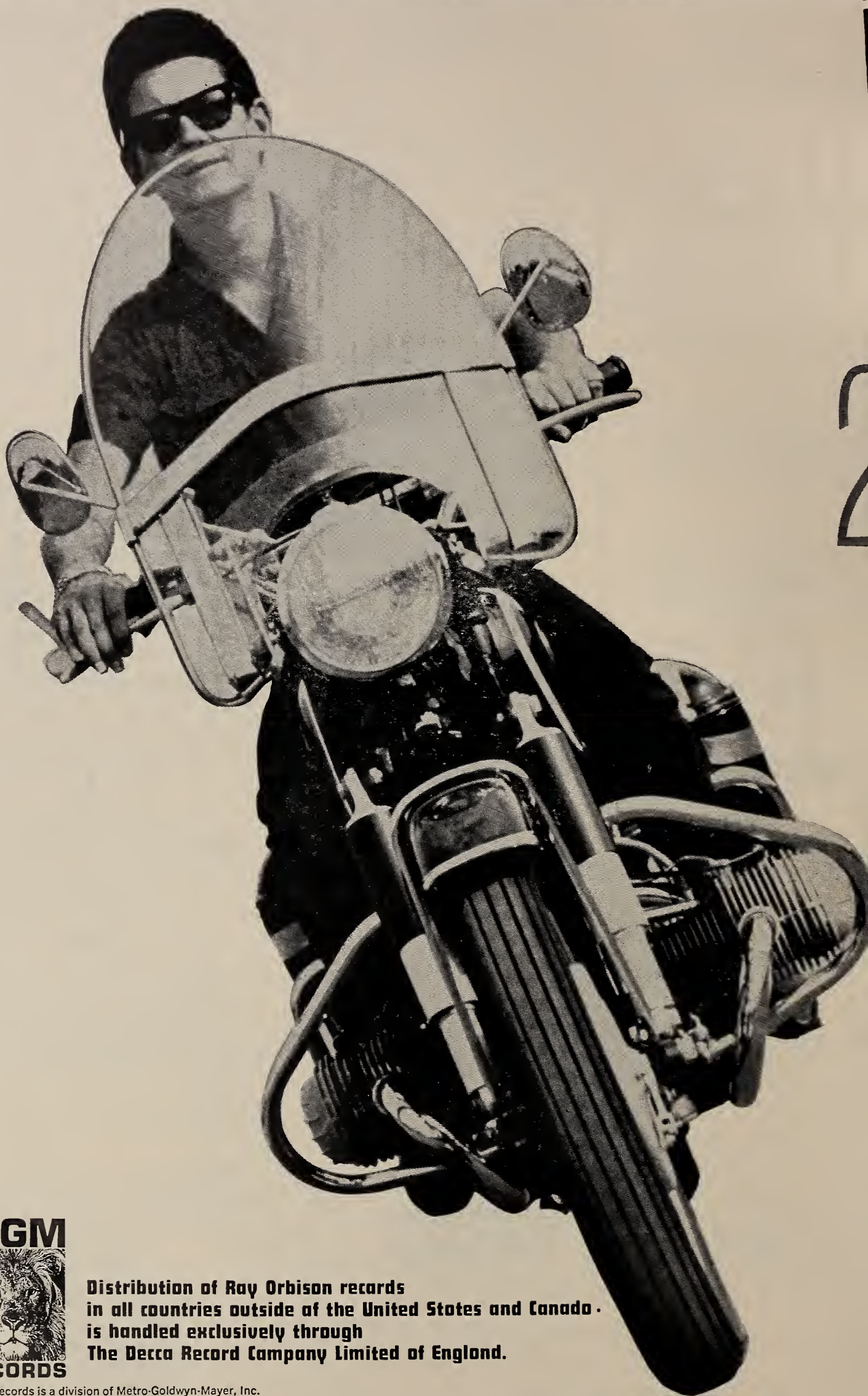

**Distribution of Ray Orbison records
in all countries outside of the United States and Canada
is handled exclusively through
The Decca Record Company Limited of England.**

MGM Records is a division of Metro-Goldwyn-Mayer, Inc.

**ROY
ORBISON**

GREAT FIRSTS...

his first MGM single!

RIDE AWAY

/w wondering...K-13386

his first MGM album!

**there is only one
ROY ORBISON**



E/SE 4308

Exclusive Management:
ACUFF-ROSE ARTISTS CORP.
Nashville 4, Tennessee
CYpress 7-5366



GREAT BRITAIN

The Beatles are back at the top of the British Hit Parade with "Help" the title song from their second film which had its world premiere in London this week attended by H.R.H. Princess Margaret and Lord Snowdon. The disk—their sixth to go to No. 1 on the day of release—notched up an advance of a quarter million. 5,000 fans cheered the group as they arrived for the premier of the film which includes six Lennon-McCartney numbers and one "I Need You" by George Harrison. The Beatles, just back from Italy, France and Spain, leave for New York on Aug. 13 (two days after the film has its American premier). They tape an "Ed Sullivan" TV'er on Aug. 14 and on the next day open their American tour at the Shea Stadium followed by dates in Toronto, Atlanta, Houston, Chicago, Minneapolis, Portland, San Diego, Los Angeles and San Francisco. They return to England on Sept. 1.

A strong contingent of RCA executives called at the Cash Box office during a recent visit to London. From RCA's American division came Steve H. Sholes, divisional vice president of popular A&R and Dick L. Broderick, manager merchandising of the International Liaison Department. They were accompanied by Peter Baumberger, vice president and managing director of RCA overseas SA Geneva and Anthony Wallace-Turner, newly appointed liaison office between RCA America and their British licencees, Decca Records. For the past six years Mr. Wallace-Turner has been with RCA-New York working with the Sales, Broadcasting and TV equipment units. Primary purpose of the visit was to explore the record scene on this side of the Atlantic and to discuss RCA artists and repertoire in relation to the European market which Broderick feels is now following the American pattern with the trend swinging away from singles towards LP's. The party later left for Stockholm and meetings with RCA executives and licencees from Sweden, Denmark, Norway, Finland, Austria, Germany, Belgium and Holland.

The following statement was issued by CBS London: Now that CBS Records Ltd. of England has been successfully established and the American Columbia catalogue fully integrated into the U.K. market (CBS has had a No. 1 hit in both singles and LP charts in addition to others in the charts) D. M. Levy and Goddard Lieberson have decided to prepare for the long term future by appointing Ken Glancy, vice president, A&R Columbia Records U.S.A., to the position of Managing Director of CBS Records England. D. M. Levy will now become Vice Chairman of the British company. This is to take effect on Oct. 1, 1965.

Peter De Rougemont of CBS-Paris in London recently was delighted to find the new CBS pressing plant working at full pressure in order to meet the demands for the company's product both from home and overseas markets. This activity is welcome at a time of the year when record sales are expected to fall and particularly this time of year when the market generally is down more than usual.

Maurice Oberstein who has been here since April helping to reorganize the CBS operation has been appointed director of operations for the factory, order service and dispatch, etc. An American formerly with CBS New York, Oberstein will remain in England indefinitely.

Mr. Fanti of RCA Italiana in London for discussions with Mr. Green of Selecta regarding the importation of disks by top RCA Italiana artistes. Fanti also met publisher Robert Mellin to discuss English lyrics for the No. 1 Italian song "Il Mondo" by Jimmy Fontana with a view to release in this country.

Leonard Bernstein flew into Britain for the first performance of Chichester Psalms—a work he had been commissioned to write for the Southern Cathedrals Festival. The work which is in three movements was performed by three cathedral choirs plus the Philomusica Orchestra of London with brass ensemble, two harps and a battery of percussion. Bernstein is expected to remain in England until Aug. 6.

Sheila Southern currently playing the summer season at Scarborough is to be featured in a new TV series in the Autumn. An offer for TV from East Germany is also under consideration. Sheila's manager Derek Boulton goes to the States on Aug. 5 for three weeks visiting Los Angeles and New York. He plans to set up a film company and look for buyers of his LP's. Boulton makes around 30 albums a year in London.

Andy Wood has now left Filmusic to set up his own independent recording/management/publishing company to be known as Giant Music. First dinking is by the Shindigs who make their debut with their own composition "One Little Letter."

Quickies: "Mr. Tambourine Man" still topping best selling sheet music lists for Leeds. . . "Make It Easy On Yourself" sing the Walker Bros. on Philips and it may well bring them an easy entry into the charts. . . Buddy Greco commences a four-week season at Talk of the Town August 9th. . . Tom Jones' American smash (currently No. 2) "What's New Pussycat" gets British release on Decca. . . Congratulations to Jonathan King climbing into the charts with his debut disk "Everyone's Gone To The Moon" (Decca). . . The Strangeloves American hit "I Want Candy" covered here by Brian Poole and the Tremeloes on Decca. . . A song for Pye international manager Peter Knight Jr.



JAPAN

Yasushi Miyagawa, Composer of such recent hit tunes as "Una Sera Di Tokyo" and "Vacance D'Amore," returned to Tokyo from a forty days journey through Europe and expressed his impression on the recent four of music festivals held in Italy, France, West Germany and Spain. He said that they all were very interesting but Italy's was the best. He also reported that he had been asked for compositions by Southern Music Company in Spain, Gene Pitney, and the New Christy Minstrels who he met at the Venecchia International Music Festival. After returning to Japan, he has been leading a busy life composing for the Takarazuka Music Opera Groups which are scheduled to have a premiere performance in Paris in a few months.

Great Britain's Best Sellers

This Week	Last Week	Weeks On Chart	Song
1	—	1	*Help—The Beatles (Parlophone) Northern Songs
2	1	5	Mr. Tambourine Man—The Byrds (CBS) Leeds
3	3	3	*You've Got Your Troubles—The Fortunes (Decca) Mills
4	9	3	We've Gotta Get Out Of This Place—The Animals (Columbia) Screen Gems
5	2	5	*Tossin' & Turnin'—The Ivy League (Piccadilly) Southern
6	8	4	There But For Fortune—Joan Baez (Fontana) Harmony
7	4	6	Heart Full Of Soul—The Yardbirds (Columbia) Feldman
8	15	2	*Catch Us If You Can—Dave Clark (Columbia) Ivy
9	7	6	In The Middle Of Nowhere—Dusty Springfield (Philips) Budd
10	5	9	I'm Alive—The Hollies (Parlophone) Shapiro-Bernstein
11	12	5	Wooly Bully—Same The Sham & Pharaohs (MGM) Becki
12	14	3	*He's Got No Love—The Searchers (Pye) Toby
13	16	2	With These Hands—Tom Jones (Decca) Kassner
14	10	6	To Know You Is To Love You—Peter & Gordon (Columbia) Bourne
15	—	1	In Thoughts Of You—Billy Fury (Decca) Coda
16	11	8	Looking Thru The Eyes Of Love—Gene Pitney (Stateside) Screen Gems
17	—	1	*Everyone's Gone To The Moon—Jonathan King (Decca) Marquis
18	—	1	A Walk In The Black Forest—Horst Jankowski (Mercury) Flamingo
19	13	6	*Leave A Little Love—Lulu (Decca) Skidmore
20	17	4	*Goodbye—Peter Cook & Dudley Moore (Decca) Essex *Local copyrights.

Top Ten LP's

- The Sound Of Music—Soundtrack (RCA)
- Bringing It All Back Home—Bob Dylan (CBS)
- Mary Poppins — Soundtrack (HMV)
- Joan Baez In Concert No: 5—Joan Baez (Fontana)
- Joan Baez In Concert Vol: 2—Joan Baez (Fontana)
- The Sound Of The Shadows—The Shadows (Columbia)
- What's Bin Did—Donovan (Pye)
- Hit Maker — Burt Bacharach (Decca)
- Beatles For Sale—The Beatles (Parlophone)
- A World Of Our Own—The Seekers (Columbia)

Top Ten EP's

- Got Live If You Want It—The Rolling Stones (Decca)
- The One In The Middle—Manfred Mann (HMV)
- Tickle Me—Elvis Presley (RCA)
- Silver Dagger & Other Songs—Joan Baez (Fontana)
- Mrs. Brown You've Got A Lovely Daughter — Herman's Hermit (Columbia)
- Dylan—Bob Dylan (CBS)
- Beatles For Sale No: 2—The Beatles (Parlophone)
- Go Away From My World—Marieanne Faithfull (Decca)
- Beatles No: 1 — The Beatles (Parlophone)
- The Seekers — The Seekers (Columbia)

The lark and pianist, Hoki Tokuda, reportedly signed a one year contract with one American music agency to join up with a combo as a pianist and songstress. The lark began piano lessons at the age of three, studied at Kunitachi Music College and Alma College in Canada for awhile before becoming a member of a girls chorus group here in Japan. Recently, she has been appearing in clubs all around the U.S.

Yoichi Hiraoka, one of the most popular xylophone soloists around, is expected to return to Japan at the end of Sept. from an American tour to appear in a Tokyo concert with the Nippon Philharmony Orchestra conducted by Andre Kostelanetz. He is reported to have had a successful performance on July 4 with Chicago Symphony Orchestra playing Japanese-oriented selections.

According to the announcement made by King Records, the firm has decided to send records and pics and to beam some tunes at British Exhibition at the International Trade Fair under the auspices of British Decca which will send articles besides records there. Fair will open during Sept. 17-Oct. 3 where the queen of Alexander will reportedly make her appearance.

King Records will release in the beginning of Sept. three LP's to honor the visit of Stanley Black here on the 12th of the month. One of them is titled "New Cuban Moonlight" which includes "Peanuts Vender" "Brazil" "Amore," etc. Other albums not titled yet even though recordings have been decided.

Toshiba Records came out on Aug. 5th with an extraordinary release by the Ventures which includes "Cruel Sea" and "A Fugitive."

Teichiku Records will release two Brenda Lee LP's on the market within the next few days. One is 30 cent LP titled "Brenda Lee In Tokyo" and the other is 17 cm LP sung in Japanese. The former one includes fifteen tunes gathered from the best of her repertory, most of which were recorded at a performance held in Shinjyuku Kosei Nenkin Hall on July 3.

Nippon Victor released on Aug. 8th the following LP's. They are "The Best Of Trini Lopez" including "What'd I Say" "Bye, Bye, Blondie" and others, "Electric Guitar Hits" gathering "Tragic Winds" "Caravan," "Billy Vaughn/Mexican Pearles" with "Peanuts Vender" and others, and "Drum! Drum! Drum!/Sandy Nelson" includes "Lonesome Drum" and others.

ARGENTINA—The Past 12 Months

It would be a wonderful thing to be able to start this yearly report with optimistic comment about the development of the industry in Argentina, but unfortunately, during the past years and also 1964/65, there have been more sad than favorable points to speak about. First it was a hard reduction of the market, in 1962/63, and now, when the trend seems to go upwards once again, the critical financial situation of the country has moved the Government to impose restrictions in currency matters that have very much affected the entire relations of the local diskeries and publishing houses with other countries.

We have already commented several times on the details, but it is worth mentioning once again. To protect its gold and hard currency reserves, the Central Bank closed in April, 1964 the free market that had been allowing unlimited remittances and imposed restrictions which meant that all operations should be approved by it. In fact, many deals related to record and publishing businesses weren't allowed because of "lack of proof"—like for instance advanced payments. Practically, there are delays from three to twelve months in the approval, meaning that many diskeries were unable to fulfill their royalty payments during this period and menacing the renewal of representation contracts with many companies from the U.S. and Europe. In spite of the regulations, the dollar exchange rate during this month jumped from 138 to 172, and there are rumors of a further deviation; thus, the real cost of a foreign label representation for the near future is almost uncertain.

Prices of records have also been increased: LP's costing 630 pesos last year are priced now around the 800 pesos mark, with their dollar equivalent remaining stable at \$4.50 because of the devaluation. The "promotional" record, once considered a sort of gun in the price battle, has become a respectable addition to the list prices, at about 600 pesos (\$3.50), which is rather high if compared with the prices marked a few years ago. The main marketing fight during this period has been held by Sicamericana, who launched first 7" records priced at 100 pesos (\$.59) with four tunes and now is re-releasing its old albums under a new series, named "Difusion Musical" (Musical Promotion), priced at 395 pesos (\$2.30). Ricardo Mejia's RM records (see last year's comment) failed because of difficulties he had with the record pressing plant.

The size of the market in itself has increased, if compared with the previous period, and one release (Philip's folk album "The Folk Mass", cut by Los Fronterizos, Ariel Ramirez and choir) sold more than 70,000 LP's in less than three months, and is still now selling well. Sales vary very much according to the artist, but a strong release gets easily to the 20,000 mark (singles). The so-called "new wave" (local teen artists) has lost some of its force during the last three months, but was very strong during all 1964 and the beginning of 1965. There are several new artists with good possibilities: Music Hall's Horacio Ascheri, RCA's Simonette, Microfon's Anita Martinez are among them. Of course Argentina couldn't escape the Beatles' wave, and besides the success of the Brian Epstein group, many others appeared on the local side: Los Iracundos (RCA); Los Buhos (CBS); Los Jets (Odeon Pops) and lately Uruguayan group Los Shakers, on the same label. Sales of The Beatles have been very good, and they rated for several months as Odeon's strongest artists. The Rolling Stones, The Dave Clark Five and Billy J. Kramer were also added to the catalog during this time.

Folk music, on its side, has remained more or less at the same level as 1964, after the '63 boom. CBS has enjoyed the growth of popularity of Jorge Cafrune, who won the 1964 Odol Song Festival with his song "Que Seas Vos", which afterwards got into the charts for many weeks. Of course, the "Folk Mass" hit should be

also credited to this field. Los Chalchaleros, Los Fronterizos and Los Quilla Huasi remain at a strong position.

Tango music made headlines during this period, although in some cases because of unfortunate news: the death of Julio Sosa in an auto crash sky-rocketed sales of his waxings (he had already been selling very well in the previous months) and a crowd estimated in 200,000 attended his mourning, something never seen before in Buenos Aires. Other big losses were Juan de Dios Filiberto and Francisco Canaro, famous because of his nearly fifty years with tango music. Sosa's record will probably hold a place beside the old recording by Carlos Gardel, who died in a plane crash in 1935 but is still Oldeon's top five artists.

There were several international visits, mainly during the past three months: Sylvie Vartan, Catherine Spaak, Nico Fidenco, Giancarlo Guardabassi, Neil Sedaka, Trini Lopez and "Route 66" ex-star George Maharis. Many Argentine artists traveled to Europe and Central and North America: Palito Ortega, Leo Dan, Juan Ramon and Roberto Yanés among them. Most important way of exposure for international star is still TV, through any of the four channels working in Buenos Aires and the other ten existing in country cities like Cordoba, Mendoza, San Juan, Rosario and others. TV is now nearly covering the whole country, and in a few years the 22 million inhabitants will be reached by this media.

In general, publishing firms have stopped releasing records for promotion purposes (see last year comment). There are few news regarding representation arrangements, and one new record company in Buenos Aires: Ala-Nicky, managed by Alaide Gorostiza. Uruguayan diskery Antar is releasing its product independently, distributed by Disc Jockey, and this has made the Ducretet-Thompson label available to the customers. Disc Jockey is now releasing Clave, another Uruguayan label, and has enjoyed big success with French Barclay, making a wonderful promotion for French music at the same time. US label Kapp passed from Tonodisc to Music Hall, while Esperon's label arranged with Tamla-Motown and was preparing a giant launching at press time. Spanish label Belter was planning its first independent releases for July-August, under the direction of Ricardo Romero.

Recording and pressing facilities have remained at the same level, with Music Hall investing heavily in the equipment for its new studios, which will be available in 1966. RCA has also plans for complete studio facilities at its factory; up to now it had been recording at Constelacion and lately at Ion, an independent studio.

An important addition to the Argentine catalog is the one made by Producciones Fermata during this period. After being affiliated to RCA, it changed to Odeon and is releasing record by artists like John Foster, Luigi Tenco, Mina and The Persuaders, which have obtained good places in the best-selling lists.

Song advances continue to be the biggest problem for music publishers. This point has been explained many times here before, and is parallel to the advances record companies have to pay (or are requested to pay) for foreign labels. In general it seems that labels and publishers from other countries consider advances as "sure money" and ask for quantities that will allow them to forget everything about it afterwards. However, this is not completely acceptable because local label have to face the launching risks alone, and in many cases they don't even receive the necessary cooperation from the original recorder. The difficulty to get the money from the Central Bank only increases the problems. Excepting special cases, \$50 to \$100 is the maximum considered "reasonable" enough as to talk business.

(Continued on page 84)

**WE HAD THE HITS IN 1964!
WE ARE DOING IT AGAIN IN 1965!**

HERE ARE THE LATEST:

**BOLERÓS EN RÍO
PALITO ORTEGA**

**CON AMOR
VIOLETA RIVAS**

**MÁS CORAZÓN QUE
NUNCA**

JUAN RAMON

**SIN PALABRAS
LOS IRACUNDOS**

**ESTAMPAS DE
ANTAÑO
JUAN D'ARIENZO**

**EN LA FALDA
ANIBAL TROILO
"PICHUCO"**

**NUESTRO FOLKLORE
EN HOLLYWOOD
LOS CHALCHALEROS**

**LA MAMMA
EDUARDO RODRIGO**

OUR SUCCESS CAN BE YOUR SUCCESS

RCA VICTOR ARGENTINA

**SOCIEDAD ANONIMA INDUSTRIAL Y COMERCIAL
Casilla de Correo 4400 — Buenos Aires — Argentina**

DISCOS



**MEANS WORLD PROMOTION
AND HITS!**

LEO DAN (ARG)

GEORGE MAHARIS (USA)

CUARTETO IMPERIAL (ARG)

BOBBY SOLO (ITALY)

ROBERTO YANES (ARG)

EYDIE GORME Y LOS PANCHOS (ARG)

JORGE CAFRUNE (ARG)

ROBERTO CARLOS (BRAZIL)

JULIO SOSA (ARG)

SYLVAIN (FRANCE)

CHARANGA DEL CARIBE (ARG)

TITO RODRIGUEZ (USA)

* Published by Melograf SRL

MI COCHE TIENE NOVIA*

LA CHICA DE IPANEMA

TRINIDAD*

SI LLORAS, SI RIES*

ENAMORADA

PIEL CANELA

QUE SEAS VOS

CALHAMBEQUE

EL FIRULETE

AMOR PERDONAME

SANTANDER DE BATUNGA*

YA SON LAS DOCE

CBS—ARGENTINA HAS THEM!!!

DISCOS CBS SAICF—Paraguay 1583, Buenos Aires, Argentina

SICAMERICANA
S.A.C.I.F.I.

PRODUCERS OF



RECORDS AND EXCLUSIVE
DISTRIBUTORS
IN ARGENTINA
OF
DOT
KAPP
REPRISE
VANGUARD



KING RECORD
ROULETTE
PACIFIC
SEECO



C.G.D.
Internazionale
DEMON
FUENTES
COPACABANA



MAYA
GAMMA
PEERLESS



RECORDS PRODUCERS OF
MOST AUTHENTIC MUSIC
OF ARGENTINA

JOSE E. URIBURU 40
Buenos Aires
ARGENTINA

ARGENTINE ALL TIME BEST SELLERS

La Cumparsita*
Mariquilla
Fueron Tres Anos*
Ella
Baion De Madrid*
Ansiedad
Bajo El Cielo De Paris
Nuestro Juramento
Rosas De La Plaza Washington
Canario Triste
Fumando Espero
La Pachanga
La Historia De Un Amor
Diana
Juan Guerrero
Danza De Buck
Delicado
La Novia
Only You
It's A Sin To Tell A Lie
Que Tarde Que Has Venido*
Adam And Eve
Ruega Por Nosotros
Celos
Serenata A La Luz De La Luna
El Jinete
Magica Luna
La Mamadera
You Are My Destiny
Moliendo Cafe
Cafe A La Italiana
Quemame Los Ojos
La Payanca*
Donde Estara Mi Vida
El Vagabundo
Y Besame Otra Vez*
Patrulla Americana
Baion Del Desierto
Ue Paisano
Sh-Boom
Makin' Wooooe
Piove
Pantalones De Fantasia
Angelina
El Sucu Sucu
Gallo Ciego
Callejero
Si Me Hablaras Corazon*
Vuela Paloma
Pity Pity
Pity Pity
Taquito Militar*
Charleston Parisien
High Noon
Brasil
Que Puntada*
Jezabel
Adios Corazon*
Recordandote*
Pepitas De Oro
Rock Around The Clock
Angelica
Presumida
Popotitos
Wheels
And the Heavens Cried
Paloma
Dame Felicidad
Limbo Rock
Puente Pexoa
Munequita
Love Me Warm and Tender
Bella Morena
Amor en Budapest
Cachito
Jumpin' the Broomstick
Lagrimas y Sonrisas
Deci Porque no Queres
Celia
Oh!
El Pescador
COMO TE Extran Mi Amor
Riders In The Sky
Lili
Et Manteinant
Por Cuatro DiasLocos
Neil Blu Dipinto di Blu
Fanny
Cuore
If I Had A Hammer
La Terza Luna
Cingarella
Por quela quise tanto
La Cumparsita
El Baile del Ladrillo
Three coins in the Fountain
Sabor a Nada
Sin Timon
Acuarela del Rio
Rio Manso
La Misa Criolla*
Como Te Extran Mi Amor*
Vestida De Novia*
Twist And Shout
Santander De Batunga*
Cumbia Sobre El Mar*
Me Permite*
Il Mio Mondo
Mama Provinciana*
Santiago Querido*
Inolvidable

Changuito Canero*
(* Local copyright)

Juan D'Arienzo
Jose Luis
Hector Varela
Miguel A. Mejia
Los 4 Amigos
Nat King Cole
Three Suns
Julio Jaramillo
Werner Muller
Dinah Shore
Hector Varela
Luis Aguile
Hector Varela
Paul Anka
Charro Avitia
David Carrol
Waldir Azevedo
Antonio Prieto
The Platters
Smith
Hector Varela
Paul Anka
Miguel A. Mejia
Frankie Laine
Glenn Miller
Miguel A Mejia
Baby Bell
Yuyu De Silva
Los Cinco Latinos
Hugo Blanco
Dany
Rosamel Araya
Muchachos de Antes
Joselito
Los Panchos
Hector Varela
Glenn Miller
Abel Ferreira
Nicola Paone
Los Tripulantes
John Gordy
Domenico Modugno
David Carroll
Eddie Calvert
Tarateno Rojas
Donato Racciati
David Carroll
Hector Varela
Miguel A. Mejia
Billy Cafaro
Paul Anka
Mariano Mores
Leo Clarens
Frankie Laine
Ray Conniff
Enrique Rodriguez
Frankie Laine
Osvaldo Pugliese
Los Cinco Latinos
Xavier Cugat
Bill Haley
Cantores de Quilla Huasi
Teen Tops
Teen Tops
Billy Vaughn
Tony Vilar
Los Cantores de Quilla Huasi
Enrique Guzman
Chubby Checker
Trovadores del Norte
Enrique Guzman
Paul Anka
Rafael Rossi
Enrique Rodriguez
Nat King Cole
Brenda Lee
Rodolfo Biagi
Palito Ortega
Leo Dan
Pee Wee Hunt
Los Wawanco
Leo Dan
Bing Crosby
Leslie Caron
Gilbert Becaud
Alberto Castillo
Luis Aguile
Leo Dan
Rita Pavone
Trini Lopez
Neil Sedaka
Carlinhos
Mariano Mores
Alfredo de Angelis
Rita Pavone
Frank Sinatra
Palito Ortega
Palito Ortega
Julio Molina Cabral
Ramona Galarza
Ariel Ramirez
Leo Dan
Palito Ortega
The Beatles
Charanga del Caribe
Cuarteto Imperial
Palito Ortega
Richard Anthony
Beto Fernan
Leo Dan
Tito Rodriguez
Palito Ortega

RCA Victor
Philips
Columbia
RCA Victor
Columbia
Capitol
RCA Victor
TK
Polydor
RCA Victor
Columbia
Odeon
Columbia
Ariel
RCA Victor
Mercury
TK
RCA Victor
Mercury
Columbia
Columbia
Ariel
RCA Victor
Columbia
RCA Victor
Odeon Pops
Odeon Pops
Columbia
Polydor
Disc Jockey
Disc Jockey
RCA Victor
Columbia
Columbia
RCA Victor
TK
TK
Mercury
RCA Victor
Music Hall
Mercury
Odeon
H y R
Sondor
Mercury
Columbia
RCA Victor
Columbia
Ariel
Odeon
Columbia
Columbia
Columbia
Odeon
Columbia
Odeon
Columbia
Columbia
Decca
Philips
Columbia
Columbia
Music Hall
Columbia
Philips
CBS
Fermata
CBS
CBS
RCA
Odeon
Odeon
Capitol
Decca
Odeon
RCA
CBS
Capitol
Odeon Pops
CBS
Odeon
Capitol
Odeon
Odeon
Odeon
CBS
RCA
Reprise
RCA
Odeon
Odeon
RCA
Capitol
RCA
RCA
Music Hall
Odeon
Philips
CBS
RCA
Odeon Pops
CBS
CBS
RCA
Odeon Pops
Music Hall
CBS
United
Artists
RCA

THE BIGGEST
ARGENTINE HIT
OF 1964/65

**THE FOLK
MASS**

(La Misa Criolla)

Now Released
On Records In:

U.S.A. - Germany - Italy
Holland - Mexico - Spain
Brazil - Chile - Peru
and many other countries

Is Published by

EDICIONES PIGAL

World Distribution By:

EDITORIAL LAGOS

Talcahuano 638

Buenos Aires, Argentina



ESTABLECIMIENTO MUSICAL

NEUMANN

FOUNDED 1880

Publishers

**NEUMANN
DOWNEY
APOLO
MELODIAS
MUNDIALES**

Nearly a
Century
With Music

**MAIPU 235
BUENOS AIRES
ARGENTINA**

ARGENTINA—The Past 12 Months

(Continued from page 83)

The future is regarded with interest (if not optimism) by the industry. The political stability attained and a certain fluency in the internal market (TV set and radio sales have soared to a many years high; there is more money available) could mean better sales. Of course, all the optimistic thoughts are somehow darkened by the currency problems, but the companies have demonstrated their ability to survive these big difficulties and may hope to meet a really very good

market if ever the situation straightens out. Several diskeries are seriously considering one or another way of record clubs, and at least two of them are gathering addresses for direct mail information and sales purposes. Although Argentina doesn't seem to be a very good country for this type of organization, the high sales obtained by the Reader's Digest releases reveal the existence of a big market which is normally out of reach for the record companies.

SMART PUBLISHERS

Santa Fe 1552 — Tel: 44-5796
Buenos Aires, Argentina

ARGENTINA: TOP SELLERS, PAST TWELVE MONTHS

Amore Scusami
Adios Adios Corazon*
Angelito
Ahora Si*
A Hard Day's Night
Alla Cara Cara Nonna*
A Toi De Choisir
Collar De Caracolas*
Charade
Calor*
Changuito Canero
Como Te Extrano Mi Amor*
Chin Chin
Cumbia Sobre El Mar*
Cataclismo
Do Re Mi
El Cardenal*
El Ajuar*
Esto*
El Firulete*
Flauta 'E Caña*
Ho Capito Que Ti Amo
Inolvidable
Il Mio Mondo
I Feel Fine
It's My Party

It's A Sin To Tell A Lie
Io Che Non Vivo Senza Te
Love Me Do
La Mula*
Lagrima Seca*
Las Cerezas
Leccion De Besos (Letkiss)
Los Domingos*
La Mañana*
La Misa Criolla*
Ma Vie
Me Permite*
My Boy Lollipop
Mama Provinciana*
Non Ho L'Eta
Ocho Dias A La Semana
Please
Papeles*
Piel Canela
Que C'Est Triste Venise
Que Falta Que Me Haces*
Que Suerte*
Que Seas Vos*
Que Te Pasa Gaucho*
Roll Over Beetboven
Sometimes On Friday
Santiago Querido*
Santander De Batunga*
Son Los Pescadores*
Si Tuviera Un Martillo
Se Piangi, Se Ridi
Twist And Shout
Trinidad*
Te Llevare*
This Night You Belong To Me
Viva La Papa
Vestida De Novia*
Ya Son Las Doce
(* Local copyright)

John Foster
Cuarteto Imperial
Trini Lopez
Beto Fernan
The Beatles
Piero
Richard Anthony
Julio Molina Cabral
Nestor Fabian
Palito Ortega
Palito Ortega
Leo Dan
Richard Anthony
Cuarteto Imperial
Cuarteto Imperial
The Cousins
Violeta Rivas
Violeta Rivas
Leo Dan
Julio Sosa
Charanga del Caribe
Luigi Tenco
Tito Rodriguez
Richard Anthony
The Beatles
Richard Anthony; Juan Ramon

George Maharis
Juan Ramon
The Beatles
Chico Novarro
Pepito Perez
Hermanos Carrion
Piero Sancho
Cinco del Ritmo
Horacio Aschieri
Ariel Ramirez, others
Alain Barriere
Palito Ortega
Millie Small
Beto Fernan
Gigliola Cinquetti
The Beatles
Frank Ifield
Palito Ortega
Eydie Gorme-Los Panchos
Charles Aznavour
Julio Sosa
Violeta Rivas
Jorge Cafrune
Palito Ortega
The Beatles
Claude Gordon
Leo Dan
Charanga del Caribe
Cinco del Ritmo
Rita Pavone
Bobby Solo
The Beatles
Cuarteto Imperial
Beto Fernan
George Maharis
Rita Pavone
Palito Ortega
Tito Rodriguez

Fermata
CBS
Reprise
Music Hall
Odeon Pops
Philips
Odeon Pops
Music Hall
Odeon
RCA
RCA
CBS
Odeon Pops
CBS
CBS
Disc Jockey
RCA
RCA
CBS
CBS
Fermata
United Artists
Odeon Pops
Odeon Pops
Odeon Pops; Juan Ramon
RCA
CBS
RCA
Odeon Pops
Philips
Disc Jockey
CBS-Music Hall
Odeon Pops
Microfon
Music Hall
Philips
RCA
RCA
Philips
Music Hall
Music Hall
Odeon Pops
Ariel
RCA
CBS
Disc Jockey
CBS
RCA
CBS
RCA
Odeon Pops
Warner Bros.
CBS
CBS
Microfon
RCA
CBS
Odeon Pops
CBS
Music Hall
CBS
RCA
RCA
CBS

WORLD WIDE MUSIC TRADE DIRECTORY

(Continued from page 69)

ASSANAND & SONS (MOMBASA) LTD.—P.O. Box 414—MOMBASA
(Station Road—Mombasa)
Phone: 3110
Cable: ASSANDSON MOMBASA
Man. Dir.: Mr. M. J. Shah
Labels (domestic): Mzuri

CAPITOL MUSIC STORE—P.O. Box 10052—NAIROBI
(River Road—Nairobi)
Phone: 277.00
Pres.: Mr. Meghji Karman Shah
Labels (domestic): CMS

EAST AFRICA MUSIC STORES, LTD.—P.O. Box 578—NAIROBI
(Government Road—Nairobi)
Phone: 209.35
Cable: MUSIC NAIROBI
Man. Dir.: Mrs. May E. Wright
Labels (others): Capitol, Columbia, Encore, His Master's Voice, Liberty, Mercury, MGM, Parlophone, Stateside, United Artists, Verve. (Representing EMI-England after Jan. 1, 1963).

EAST AFRICA RECORDS, LTD.—P.O. Box 30256—NAIROBI
(Mansion House—Nairobi)
Phone: 580.88
Cable: TOPTEN NAIROBI
Pres.: Mr. A. D. Harris
Labels (domestic): Jamba, Nyota, Salaam, etc.

SHAH ZAVERCHAND DEPAR & BROS.—P.O. Box 8142—MOMBASA
(Dickson Road—Mombasa)
Partners: Mr. Z. D. Shah & Mr. S. D. Shah
Labels (domestic): Arrow, Kenyas

KOREA

MUSIC PUBLISHERS

UNION MUSICAL PUBLISHING CO., LTD.—C.P.O. Box 2696—SEOUL
(94-3 Sam-Sun-Dong (5th Street)—Sung Buk Ku—Seoul)
Phone: 73-2467
Pres.: Mr. Hong Ryon Kim

(Continued on page 86)

JULIO KORN PUBLISHERS

sincerely thanks all those new firms abroad who have lately trusted their catalogues and most well-known production to the effectiveness of our organization;

and takes advantage to renew its gratefulness to those who have bestowed their confidence and collaboration on us for so many years, at the same time they root the image of our company abroad. —

wire:
EDIKORN

JULIO KORN PUBLISHERS

Moreno 2034 — Buenos Aires — ARGENTINA

ARGENTINA—RECORD COMPANIES

ALA-NICKY SRL

Alsina 1535, Buenos Aires
Manager: Alaide Gorostiza
Tel: 494218

DISC JOCKEY SRL

Manager: Manuel Rodriguez Luque
Pedro Goyena 72, Buenos Aires
Tel: 92-9090
Labels: Disc Jockey, Palette, Continental, Meazzi, Barclay, Artone, Cbantecler

DISCOS BEMOL

Alsina 3089, Buenos Aires
Label: Bemol

DISCOS AVENIDA

Manager: G. Kotliarenko
Av de Mayo 1222, Buenos Aires
Label: Avenida

DISCOS CBS S.A.

Paraguay 1583, Buenos Aires
Vice President: Juan Truden
Commercial Director: Douglas Taylor
Labels: CBS, Columbia, Orfeo

DISCOS RC

Dean Funes 1064
Rosario, Pcia. de Santa Fe
Artistic director: Pedro Lujan
Label: RC

DISCOS SERENATA SRL

Manager: G. Capdevila
Esmeralda 433, Buenos Aires
Tel: 490440
Label: Serenata

FAMOUS SRL

Manager: Ian W. Morris
Peru 1511, Buenos Aires
Tel: 263306
Labels: ABC Paramount, Musidisc, Ariel

EDITORIAL ABRIL

Manager: C. Civita
Av Alem 884, Buenos Aires
Label: Fonorama

DISCOS CICLOPE

Manager: M. Perrotti
Virrey Cevallos 1152, Buenos Aires
Label: Ciclope

FLAMINGO

Manager: G. Angeletti
Belgrano 1666, Buenos Aires
Label: Flamingo

H y R

Manager: H. Maluf
Alberdi 157, Ciudad de Salta
Label: H y R

INDUSTRIAS ELECTRICAS Y MUSICALES ODEON S.A.

Manager: Philip Brodie
Corrientes 485, Buenos Aires
Tel: 496651
Labels: Odeon, Odeon Pops, London, Decca, Liberty, Warner Bros., Capitol, Angel

DISCOS FENIX S.A.

Bouchar 644, Buenos Aires
Label: Fenix, TK

MICROFON SRL

Manager: Mario Kaminsky
Lavalle 1759, Buenos Aires
Tel: 496128
Labels: Microfon, Audio Fidelity, Canadian American, Cbancellor, Cadence, Everest, Coral, Durium, Supraphon

PHONOGRAM S.A.

Manager: Maximo Wyngaard
Cordoba 1351, Buenos Aires
Tel: 411555
Labels: Philips, Polydor, Mercury, MGM, DGG, Archiv, Heliodor

PRODUCCIONES FERMATA (Discos) SRL

Manager: Mauricio S. Brenner
San Martin 640, Buenos Aires
Tel: 319330
Labels: Fermata, RGE, Cameo-Parkway

RECORD MUSICAL SRL

Manager: Hugo Torres
Belgrano 1870, Buenos Aires
Label: Record

RKM SRL

Manager: Juan Kallay
Lavalle 2016, Buenos Aires
Label: RKM, Amadeo

RCA VICTOR ARGENTINA SA

Sales & Promotion Manager: Adolfo Pino
Paroissien 3960, Buenos Aires
Labels: RCA, Vik, Camden, Victrola, Ariola

SICAMERICANA SACIFI

Pres.: Nestor Selasco
VP: Luis Calvo
Jose E. Uriburu 40, Buenos Aires
Tel: 469808
Labels: Music Hall, Demon, Reprise, CGD, Fonit, Gamma, Roulette, Seeco, Vanguard, Fuentes, Dot, Copacabana

SURCO IND. MUSICALES SRL

Tucuman 431, Buenos Aires
Managers: Enrique Iriberry and Atalio Suva
Tel: 32 3143
Labels: Opus, Vox, United Artists, Atlantic, Telefunken

SVELT SRL

Corrientes 2322, Buenos Aires
Label: Svelt

TONODISC SRL

Manager: Jorge Esperon
15 de Noviembre 1287, Buenos Aires
Labels: Command, Kapp, Tonodisc, Westminster, Hickory

TROVA SRL

Corrientes 2434
Tel: 479996
Buenos Aires, Argentina
Label: Folkways, Pacific Jazz

VOXOR SRL

Vernet 376, Buenos Aires
Label: Voxor



ALBERTO MARINO



RICARDO REY



PEPITO PEREZ

We Promote Them
They Sell
DISC JOCKEY RECORDS

The BIG label
PEDRO GOYENA 72, BUENOS AIRES, ARGENTINA

MICROFON

means money to you!!

- * Wide distribution & promotion net
- * Great distribution facilities
- * Big catalog with local recordings with the so much appreciated Latin touch which you may release in your country

Contact MICROFON

Lavalle 1759, Buenos Aires, Argentina

ARGENTINA—MUSIC PUBLISHERS

ALA-NICKY
Manager: Alaide Gorostiza
Alsina 1535, Buenos Aires
Tel: 494218

EDITORIAL JULIO KORN SRL
Manager: Ricardo Korn
Moreno 2034 Buenos Aires
Tel: 487709
(Julio Korn, Vitale, Mundo Musical, Odeon, Ramar, Europa, Tierra Linda, Sucesos, Iadrola, Latin Music)

EDICIONES INTERNACIONALES FERMATA SRL
Manager: Mauricio Brenner
San Martin 640, Buenos Aires
Tel: 319330
(Fermata, Novel, Roma)

EDITORIAL EDAMI
Manager: Alberto Martinez
Lavalle 1494, Buenos Aires
(Edami, Acorde)

ESTABLECIMIENTO MUSICAL NEUMANN SRL
Manager: Carlos Di Liscia
Maipu 235, Buenos Aires
Tel: 465343
(Neumann, Downey, Apolo)

SMART EDICIONES MUSICALES SRL
Manager: Romiglio Giacompoli
Sante Fe 1552, Buenos Aires
Tel: 445796
(Smart)

EDITORIAL LAGOS
Manager: A. Lagos
Talcahuano 638, Buenos Aires
Tel: 403746
(Lagos)

SPRINT MUSIC
Manager: H. Celano
Lavalle 560, Buenos Aires
(Sprint)

EDICIONES MUSICALES TEMPO
Manager: Francisco Onorato
Cangallo 1765, Buenos Aires
Tel: 494182
(Tempo, Mundo Guarani)

EDITORIAL PERROTI
Manager: Maximo Perroti
Virrey Cevallos 1152, Buenos Aires
(Perroti)

EDICIONES MUSICALES RELAY
Paroissien 3960, Buenos Aires
(Relay)

MELOGRAF
Manager: Stanko Jerebic
Charcas 1422, Buenos Aires
(Melograf)

EDITORIAL PIROVANO
Manager: Vda de Pirovano
Pasco 1267, Buenos Aires
(Pirovano)

COMAR
Montevideo 641, Buenos Aires

RICORDI AMERICANA SA
Cangallo 1570, Buenos Aires

EDITORIAL BEMOL
Alsina 3089, Buenos Aires

EDITORIAL SELECT
Manager: O. Rubinstein
Callao 420, Buenos Aires

EDITORIAL ESCALA
Juncal 2535, Buenos Aires

EDITORIAL EMBA
Talcahuano 395, Buenos Aires

ARGENTINE RECORD PRESSING PLANTS

INDUSTRIAS ELECTRICAS Y MUSICALES ODEON SA
Corrientes 485, Buenos Aires

RCA VICTOR ARGENTINA SA
Paroissien 3960, Buenos Aires

DISCOS CBS SA
Paraguay 1583, Buenos Aires

INTER BAS CICSA
Bouchard 644, Buenos Aires

GALVADISC
Once de Setiembre 481,
Ciudadela, Poia de Buenos Aires

CONTINENTAL
Superl 3530, Buenos Aires

PLASTIGAL SA
Francisco Bilbao 2248
Tel: 636534
Buenos Aires

ARGENTINE JACKET MANUFACTURERS

ALPHA SA
Ecuador 935, Buenos Aires

IMPRIMEX SRL
Gascon 1437, Buenos Aires

D'ARRUDA DEL PUP SA
Velez Sarsfield 101, Buenos Aires

BERKO FINKEL-ARTES GRAFICAS SUPER
Mercedes 2168, Buenos Aires

LAGENHEIM HNOS
Pichincha 1484, Buenos Aires

SERRATORE
Azara 496, Lomas de Zamora,
Provincia de Buenos Aires

CURT LATTE
Ereznano 3021, Buenos Aires

ARGENTINE RECORDING STUDIOS

INDUSTRIAS ELECTRICAS Y MUSICALES ODEON SA
Corrientes 485, Buenos Aires

DISCOS CBS SA
Paraguay 1583, Buenos Aires

ESTUDIOS SAN MARTIN
Tucuman 451, Buenos Aires

ESTUDIOS ION
Hipolito Yrigoyen 2512, Buenos Aires

ESTUDIOS CONSTELACION
Belgrano 1666, Buenos Aires

SICAMERICANA SA
Jose E. Uriburu 40
Buenos Aires

WORLD WIDE MUSIC TRADE DIRECTORY

(Continued from page 85)

RECORD MFRS

MIDOPA RECORD CO.—P.O. Box 58—PUSAN
(33- 1-ka, Namboomin-Dong—Pusan)
Phone: 2-1885
Pres.: Mr. Chung Soo Rim
Labels (domestic): Midopa

YUNG CHANG INDUSTRIAL CO., LTD.—99, Ta-Dong, Chung-Ko—SEOUL
Phone: 72-3357, 72-3563, 75-3157
Cable: YUNGCHANG SEOUL
Pres.: Mr. Kim Jai-Chang
Labels (domestic): Universal

KUWAIT

RECORD MFRS

UNION TRADING CO.—P.O. Box 28—KUWAIT
(Fahd Al Salem Street—Kuwait)
Phone: 34.720, 33.673
Cable: TRADECOY KUWAIT
Pres.: Mr. Abdur Razzaq Razzaqi
Import and distribution of most of the International labels.

LEBANON

RECORD MFRS

A. CHAHINE & FILS—P.O. Box 1729—BEIRUT
(Rue Georges Picot—Beirut)
Phone: 24 28 88 & 23 16 95
Cable: CHAHINEMUSIQUE BEIRUT
Pres.: Mr. Joseph A. Chahine
Labels (domestic): Voix de l'Orient
Labels (others): Capitol, Chant du Monde, Ducretet-Thomsen, Liberty, Mercury, M.G.M., Odeon, Parlophone, Pathé, Philips, Stateside, Top Rank, Vogue.

ETS. EMILE S. KHOURY—P.O. Box 3135—BEIRUT
(Bab Edris—Beirut)
Phone: 29 03 03, 22 60 31
Cables: SUCCES BEIRUT
Pres.: Mr. Emile S. Khoury
Labels (domestic): Duniaphon
Labels (others): Archiv-Produktion, Deutsche Grammophon, Polydor

LES FILS DE GEORGES HADDAD & CO.—P.O. Box 4680—BEIRUT
(Rue Gouraud—Beirut)
Phone: 22 11 96, 24 42 04
Cable: CINEMPIRE BEIRUT

Co-partners: Mr. Michel G. Haddad
Labels (others): Atlantic, Bel Air, Cameo/Parkway, Erato, Festival, Jolly, Kapp, Music, Palette, Priam, Riff, 20th Century Fox, United Artists.

THE METROPHON RECORD CO. (Mitr Murr & Fils)—P.O. Box 1211—BEIRUT
(Rue Weigand—Beirut)
Phone: 22 38 08
Cable: MITRI MURR BEIRUT
Pres.: Mr. Mitr Murr
Labels (domestic): Metrophon
Labels (others): Argo, Brunswick, Coral, Decca, L'Oiseau-Lyre, London, RCA Camden, RCA Victor, Telefunken.

RIMAPHONE RECORDS CO.—P.O. Box 4902—BEIRUT
(Rue Mere Jilas—Center Building—Beirut)
Phone: 24 35 69, 29 06 40
Cable: RIMAPHON BEIRUT
Pres.: Mr. Mohamed Salman
Labels (domestic): Rimaphon

PRESSING PLANTS

SOCIETE LIBANAISE DU DISQUE (SAL)—P.O. Box 4680—BEIRUT
(Arris & Kanafani—Empire Building—Beirut)
Phone: 22 11 96, 24 42 04
Cable: CINEMPIRE BEIRUT
Pres.: Mr. Mario G. Haddad

LIBERIA

RECORD MFRS

C. F. WILHELM JANTZEN (LIBERIA) LTD.—P.O. Box 300—MONROVIA
(Bushroad Island—U.N. Drive—Vaitown—Monrovia)
Phone: 449
Cable: JANTHOR MONROVIA
Mgr.: Mr. Joachim Heins
Labels (others): Archiv-Produktion, Columbia, Coral, Deutsche Grammophon, Dot, Heliodor, M.G.M., Polydor, United Artists.

ELECTRONIC—P.O. Box 207—MONROVIA
(74 Broad Street—Monrovia)
Phone: 679
Cable: WEHBE MONROVIA
Owner: Mr. George Wehbe
Labels (domestic): Palmatone
Labels (others): Barclay, Brunswick, Decca, London, RCA Camden, RCA Victor, Vogue.

LIBYA

RECORD MFRS

V. TINE CASA MUSICALE—Sciara Istiklal 95-97—TRIPOLI
Phone: 34.375
Cable: TINE PIANOFORT TRIPOLI
Represents the Decca (England) group of records.

MALAGASY (Madagascar) COLLECTING SOCIETIES

FI.M.M.E.M.A.—FIKAMBANAN' NY MPANORATRA SY MPAMORONKIRA ARY EDITORA MALAGASY—Boite Postale 1288 Anakakely—TANANARIVE
(28, Araban'ny Fahaleovantena—Tananarive)
Phone: 09.91
Cable: FIMMEMA TANANARIVE
Pres.: Mr. Rasoanaivo

RECORD MFRS

DE COMARMOND & CIE., S.A.R.L.—Boite Postale 1071—TANANARIVE
(119, Avenue de la Réunion—Tananarive)
Phone: 09-49
Cable: COMARMOND TANANARIVE
Labels (domestic): Discomad, Rex
Labels (others): Festival, Stella

MALAYSIA

RECORD MFRS

BORNEO CO., LTD.—P.O. Box 898—SINGAPORE
(Crosby House—71 Robinson Road—Singapore 1)
Phone: 76181
Cable: BORNEO SINGAPORE
Mgr.: Mr. W. K. Young
Labels (others): Angel, Baidaphon, Cairophon, Capitol, Columbia, Encore, His Master's Voice, M.G.M., Odeon, Parlophone, Soutelphon, Stateside, Verve, and others.

E. S. ISAAC & CO., LTD.—P.O. Box 719—SINGAPORE 1
(1168-A, Cecil Street—Singapore 1)
Phone: 78466
Cable: ISAACNCO SINGAPORE
Gov. Dir.: Mr. M. E. Isaac
Labels (others): Reprise, Telefunken, Time, Vox, Warner Bros.

PARAMOUNT & CO.—6, Tiong Bohru Road—SINGAPORE 3
Phone: 75786
Cable: PARAWHOLE SINGAPORE
Pres.: Mr. Ow Joo Hoe
Labels (others): Dot, Imperial, Kapp

WILLIAM JACKS & CO. (MALAYA) LTD.—P.O. Box 2150—SINGAPORE 9
(160, Clemenceau Avenue—Clemenceau House—Singapore 9)
Phone: 26470, 26511
Cable: EXPANDED SINGAPORE
Pres.: Mr. H. F. Clements
Labels (domestic): Fontana, Philips
Labels (others): Audio Fidelity, Caedmon, Jazzland, Mercury, Riverside, Smash.

MALTA

RECORD MFRS

ANTHONY D'AMATO—98/99 St. John's Street—VALLETTA
Phone: 24348
Cable: GRAMOPHONES MALTA
Pres.: Mr. W. M. D'Amato
Labels (domestic): Damato Disc
Labels (others): Ember, Gala, Oriole, Saga, Vox and the EMI group of records.

P. CARABOTT—17 Merchants Street—VALLETTA
Phone: 26205
Cable: TUNEFUL MALTA
Pres.: Mr. L. Carabott Sr.
Labels (others): Archiv-Produktion, Brunswick, CBS, Columbia, Coral, Decca, Deutsche Grammophon, Fontana, London, Mercury, Philips, Polydor, Vogue.

MONGOLIAN PEOPLE'S REPUBLIC

EXPORT & IMPORT

MONGOLIAN STATE BOOK TRADE—Lenin Street 41—ULAN-BATOR
Phone: 22312
Cable: MONGOLIAN STATE BOOK ULANBATOR
Pres.: Mr. Nanzad
Only organization to be contacted in questions of export or import of ready-made culture goods (records and sheet music editions).

MOROCCO

RECORD MFRS

ATLAS DISTRIBUTIONS—31 Rue de Charmes—CASA-BLANCA
Phone: 676-51
Cable: TELEOFI CASABLANCA
Pres.: Mr. H. de Boysson
Labels (others): BBC, Decca, London, Omnivox, RCA Victor, Twist

BOUDROIPHONE—102-104 Route de Mediouna—CASABLANCA
Phone: 627-04
Cable: BOUDROIPHONE CASABLANCA
Pres.: Mr. Ahmed Boudrol
Labels (domestic): Boudroiphone

DISCO MAGHREB—21, rue Soldat Roch—CASA-BLANCA
Phone: 414-50
Cable: DISCOREB CASABLANCA
Pres.: Mr. Abdelhay Laraki
Labels (domestic): Baidaphon, Voix du Maghreb
Labels (others): Boussiphon, Sous-Phon

ORIKAPHONE S.A.R.L.—Boite Postale 3105 Roches Noires—CASABLANCA
(10, rue de la Victoire, Roches Noires—Casablanca)
Phone: 447-16
Cable: ORIKAPHONE CASABLANCA
Pres.: Mr. Ahmed El Hih
Labels (domestic): Orikaphone

ROYALE SODIFILM & LA VOIX DE L'AFRIQUE—80, avenue Lalla Yacout—CASABLANCA
Phone: 221-06, 706-97
Cable: SODIFILM CASABLANCA
Pres.: Mr. Abbas Benjelloun
Labels (domestic): Baidaphon Maroc, Voix de l'Afrique

SOCIETE MAROCAINE PHILIPS—304, Boulevard Mohammed V—CASABLANCA
Phone: 439-92/96
Cable: PHILIPS CASABLANCA
Pres.: Mr. Ali Bargach
Labels (domestic): Philips

(Continued on page 90)

Congratulations from Surco

OPUS



Surco Industrias Musicales

Tucuman 439
Buenos Aires — Argentina

ALA—NICKY S.R.L.

Record Company — Music Publishers

Buenos Aires — Alsina 1535 — Tel: 494218

New York — 665 Fifth Ave., N.Y.C. — Tel: 751-3270

S. AFRICA—The Past 12 Months

It has been a year of excitement and sadness—exciting for the number of unprecedented occurrences on the South African Record scene—and sad to the loss of South Africa's best loved recording star—the late Jim Reeves.

ARTISTS BY OVERSEAS RECORDING ARTISTS

A flood of top flight recording stars came to South Africa this past year—some fleetingly (as in the case of British pop singers, Adam Faith and Dusty Springfield—who left contracts uncompleted, and returned to Britain after they had gained much publicity through flaunting our Government's No multi-racial audiences clamp down") and some visiting recording artists came to stay and triumph on stage and in the record market.

Among the artists who came and conquered were: John Gary, Marlene Dietrich, Slim Whitman, Vera Lynn, Russ Conway, David Whitfield, Ruzhitz and Landauer, Max Bygraves, The Dutch Swing College Band, Jimmie Rodgers, Jackie Trent, Peter Gordon, Carole Deene. Never before have we had such a line-up of top recording talent visiting our country.

An interesting report comes from the Gallo Group Ad Manager who states "Show wise some artists were always playing to jam-packed houses, but there is a difference in appeal and more important the sales result attached to each artist, the type of public to whom they appeal—e.g.: The Dutch Swing College Band played to all houses wherever they went, but meant comparatively less than Jimmie Rodgers in record sales."

LOCAL RECORD STARS

Beatlemania hit South Africa with dynamic force, and the noticeable upsurge in the popularity of local recording artists was to a large extent a direct result of the Beatle's fantastic world wide success. The style they created washed up on local teen talent and gave them new incentive. This in turn livened up the whole local artists recording scene, and is emphasized in the best selling record charts supplied by the South African Record Companies (accompanying this article).

Local artists appearing on these charts include: The Hi-Lites, Charles Jacobie, Dana Valery, Billy Forest, Nick Potgieter and MacMillan & His Men. Top local talent was forced out of some companies' best seller lists by the popularity of big selling American and British artists.

Amongst the top South African artists to fare in this way were: Virginia Lee, Santa Vorster, Maureen Moore, Wanda Arletti, Johnny Kongos, Dickie Loader & The Blue Jeans, Nico Carstens, Gene Rockwell, Nick Taylor.

NOTES & COMMENTS

E.M.I.'s-P.R.O. in South Africa reports that although for them the last 12 months were heavily dominated by the Mersey-beat, the gradual establishment of the Tamla Motown sound was evident with such artists as: The Supremes, Marvin Gaye and The Miracles—receiving enthusiastic acclaim. This, despite the big beat of The Beatles from Britain, Cliff Richard & The Shadows, The Animals, Manfred Mann, Hermans Hermits, The Dave Clark 5 and others.

From America, E.M.I. South Africa, did well with The Everly Bros., The Chipmunks, The Ventures, Julie London, Connie Francis, The Kingston Trio and many more. The late Nat King Cole continues to be a best seller.

The Gallo Group reports that during 1965 the Phillips label by mutual arrangement moved from Gramophone Record Company to Trutone.

Two fine sound track recordings of South African made films were released. Both films having an African story. The first LP—Dingaka (Gallo) has secured an international release, and the second LP—Tokolshe (Teal) has enjoyed excellent sales in the local market, and negotiations are in progress for its international release.

Teal Record Company reports heavy trading with their catalogues of big name stars which included Elvis Presley, John Gary, Trini Lopez, Mario Lanza, Dean Martin, Jim Reeves, Eddy Arnold, Perry Como, Frank Sinatra, The Kinks, The Ivy League, The Searchers, Donovan, Petula Clark, Sandie Shaw, Johnny Rivers, Jackie Trent and many more.

The tragic death of Jim Reeves stunned and shocked the public of South Africa—newspaper "bill posters"—newspapers and magazines throughout the country ran the news of his death in banner headlines. Obituary programs and special radio tributes were carried on all broadcasting services. Overnight almost, people in their thousands began piling into record stores around the nation, requesting and buying Jim Reeves records. As a result of this wave of buying on an unprecedented scale, The South African Record Industry's sales figures shot up dramatically. The Record Industry figures for July, August, September 1963 and 1964 show an increase for the latter year of 25.7% unit sales. Of this percentage increase—just on ¾ was achieved by Teal Record Company, and a large proportion of the business was Jim Reeves.

THE L.M. DISCOTHEQUE

South Africa's first and still its only Discotheque, was opened this year under the sponsorship of Lourenco Marques Radio Station. The Discotheque is situated in one of Durban's swankiest Beach front hotels. Durban is South Africa's foremost shipping port, and with its miles of golden beaches—South Africa's premier holiday resort. The L.M. Discotheque enjoys tremendous crowds and has been a great success from its inception.

THE FOLK SONG IN SOUTH AFRICA

With folk going great guns in the U.S.A. and Britain, we knew it could not be long before something similar happened here, but, we were on the point of giving up waiting altogether, when the first symptoms were registered in the latter part of the first half of 1965. The Johannesburg University held a Folk Festival—folk singers were being booked by Clubs and Hotels, Rock and Beat groups were dissolving to form as Folk Groups. Recording Companies reacted to these long awaited signals promptly and folk recordings, many of a very high standard, were released in increasing quantities.

BROADCASTING ROYALTIES

Another unprecedented happening of the past year is that the South African Parliament has passed a Bill which will free Radio Stations and other users of records for public performance in South Africa, from paying a remuneration to the record producers or the artists whose performances are reproduced. The Broadcasting and Performing Rights in records have been recognized for almost 50 years in South Africa under its 1916 Copyright Act. The recognition of such rights is maintained in modern legislation in many Commonwealth and Continental countries, and is a principal embodied International Convention for the protection of performers, producers of phonograms and broadcasting organizations, adopt-

S. AFRICA—Best Selling Records

TEAL RECORD CO. LTD.

SINGLES

1. I Guess I'm Crazy	Jim Reeves	RCA 41.751
2. Ain't That Loving You Baby	Elvis Presley	RCA 41.756
3. My Seun Mealie Pap	The Hi-Lites	TS 59
4. Downtown	Petula Clark	PY 17
5. Lemon Tree	Trini Lopez	R 20.336

LONG PLAY

1. This Is It	Jim Reeves	RCA 31.898
2. Catch A Rising Star	John Gary	RCA 31.798
3. Trini Lopez at PJ's	Trini Lopez	R 6093
4. Roustabout	Elvis Presley	RCA 31.920
5. Love Song Of The Waterfall	Slim Whitman	IRL 338

FIVE BEST SELLING SINGLES

1. A Hard Day's Night	The Beatles	SPD 331
2. Do Wa Diddy Diddy	Manfred Mann	SAB 2051
3. I Could Easily Fall	Cliff Richard	DSA 564
4. I Feel Fine	The Beatles	SPD 341
5. Blue Winter	Connie Francis	MGM 19219

FIVE BEST SELLING LP'S

1. A Hard Day's Night	The Beatles	PM CJ 1230
2. Beatles For Sale	The Beatles	PM CJ 1240
3. Wonderful Life (Film Soundtrack)	Cliff Richard	33JSX 1628
4. Dance With The Shadows	The Shadows	33JSX 1619
5. The Beatles' Songbook	The Hollyridge Strings	T 2116

GALLO (AFRICA) LIMITED: 161 President St., Johannesburg

BEST SELLING SEVEN SINGLE RECORDS

Continental PD7-8805	I'm Leaving It Up To You	Dale & Grace
Decca FM7-7077	Someone Someone	Brian Poole & The Tremeloes
Continental PD7-8813	Hello Dolly	Louis Armstrong
Decca FM7-7045	As Usual	Brenda Lee
Continental PD7-8888	Pretty Woman	Roy Orbison

BEST SELLING LONG PLAYING RECORDS

Polydor LPHM 46810	Elizabeth Serenade	Gunther Kallman Choir
Polydor LPHM 46865	Kallmann Serenade	Gunther Kallman Choir
Continental ZA 6226	Hello Dolly	Louis Armstrong
Decca LK 4438	12 x 5	The Rolling Stones
Decca LK 4605	The Rolling Stones	The Rolling Stones

TRUTONE LIMITED: P.O. Box 9299, Johannesburg

BEST SELLING SEVEN SINGLE RECORDS

Renown N 1381	Hello Operator	Billy Forrest
Fontana TF 710	My Boy Lollipop	Millie Small
Renown N 1386	Do What You Do Do Well	Ned Miller
Dot D 438	Bon Soir	Jimmy Rogers
Dot D 432	Don't You Just Know It	Pat Boone

BEST SELLING LONG PLAYING RECORDS

Dot DLP 3511	My Favorite Songs	Billy Vaughn
Philips PSK 3205	The Dutch Swing College Goes Western Via S. Africa	The Dutch Swing Band
United Artists UAL 3346	50 Fabulous Organ Favourites	Sir Julian
Pèrel PLS 7087	Nick Speel Dat Dir Bars	Nick Potgieter
Rave RMG 1202	The One and Only Mack	Macmillan

GRAMOPHONE RECORD COMPANY LIMITED: P.O. Box 2445, Johannesburg

BEST SELLING SEVEN SINGLE RECORDS

Philips SSP 887	Don't Let The Rain Come Down	Serendipity Singers
Philips SSP 882	Juliet	The Four Pennies
Mercury MRC 1058	The Wedding	Julie Rogers
CBS SSC 418	Mocking Bird Song	Charles Jacobie
CBS SSC 479	This Is My Prayer	Dana Valery

BEST SELLING LONG PLAYING RECORDS

CBS ALD 6692	The Best of Charles Jacobie	Charles Jacobie
CBS BLD 7255	My Fair Lady	Sound Track
CBS BLD 7100	My Fair Lady	Stage Show
CBS ALD 6734	I'll Pray For You	Charles Jacobie
Philips PSK 3197	Jazz Sebastian Bach	Les Swingle Singers

ed at a conference in Rome in October 1961, which the U.S.A. attended.

EXPANDING MARKET

The natural growth in the population, the Government immigration program coupled with the Coloured and African record buyers becoming each year more interested in the English language pop product, results in an expanding market for South Africa.

To illustrate this, South African Record Industry figures show the following percentage increase from 1962 onwards:

LP's	
1963.	6.36% increase over 1962.
1964.	17.14% increase over 1963.

SINGLES	
1963.	17.65% increase over 1962.
1964.	2.65% decrease over 1963.

Unlike most record markets, the South African consumer has not shown an ever increasing tendency to favor the Single. The LP has remained the favorite type of record, and as the figures show—Singles sales dropped off considerably in 1964.

BRAZIL—The Past Twelve Months

Although the political situation in Brazil has definitely made a turn for the best, as we had predicted last year at this time, an era of sacrifice for the population started, as far as the economical situation is concerned, a reflex of the 30 odd years of misgovernment left behind. This fact has naturally influenced the record industry in this country, not allowing the long expected great impulse in record sales, considering the interest of the public in general, the plans of the recording companies, the new tendencies of the local popular music, the continuing infiltration of foreign musical product. However, we can safely say that, during the past few months, this expected sales increase has been slightly felt, and so has been reported by the main recording firms of Brazil. The figures have increased to the highest levels ever and it is very possible that, with the new planned stabilization of prices, they will go on up during the next months, specially with the approaching Christmas/New Year seasons. Naturally, we always have to consider one fact that has no similar in other countries, which is the relation between record sales and the Carnival (Mardi-Gras) period: at this very special time, the sales of regular product, gives way to the special material, produced expressly for that short period of festivities. This year, another fact influenced substantially the normal record sales in this country: the celebrations of the 400th Anniversary of the City of Rio de Janeiro—not only special musics and records (singles, doubles and albums) were produced and released specially for it, but also with a direct view to sell to a special and unusual prospective customer, the enormous amount of foreign tourists who attended these celebrations. Probably, this fact will influence the future export of Brazilian Pop Music material, if the local firms will finally concentrate in that potentially very strong market.

As the months went by, a definite

switch was being felt, towards the public's appreciation of the local music, in detriment of the imported—Italian artists, so very popular last year and at the beginning of this one, were losing field to the Brazilian ones. A good trial of the return of American artists to the public's preference, had moments of appreciation, but did not succeed to dethrone the local artists—the same with the French. There is no doubt that the responsibility for this all, has been the Brazilian Modern Popular Music, or Bossa Nova, as one prefers to call it. It definitely conquered more and larger audiences with each new concert of the many that were being produced both in Rio, and very specially in Sao Paulo, which became the home of MPM, against predicted by experts of former times. At the "Teatro Paramount" we could witness as crowds gathered to applaud consecrated names and excellent newcomers as well. All Universities were sponsoring this type of show, both in theaters and in their own establishments. Clubs and Societies were engaging artists from all over the country, to take part in shows and concerts, featuring the best of BNN. Finally, TV and Radio stations joined in, presenting more and better programs and shows, in which the star was MPM. We can safely say that one of the responsible for this new movement was Walter Silva "Picapau," but other names are equally important, like producer Abelardo Figueiredo, Joao Evangelista, as well as publicity man Lyvio Rangan, Jose Scatena, and several others. At this time, the "First National Festival of Brazilian Modern Popular Music" was taking form—in spite of the mistakes, forgivable in a first such venture, it was more than proven that the material is there, the artists exist in quantity and quality to present it, last but not least, the public is ready to accept and to give prestige to this new manifestation of good taste, of high artistic average, of advanced and personal popular music,

probably the very best in the world today. Teatro Record also joined in the movement, contracting representative artists, producing shows and presenting video-tapes of the same in Channel 7—Bob Corte Real had something to say there too. Besides the own activity stirred by the Bossa Nova movement, there is no doubt that it somehow awakened the other currents of Brazilian Pop Music—Traditional Samba and Folklore Music, started to reclaim their place, stating that BN is not the only music of Brazil. New programs and shows of both appeared now—interesting to note how each one of these different types of local music started feeling the influence of each of the others, how old-timers adhered to BN, even Folklore Northeast songsters were presenting MPM artists in their shows.

During these past twelve months, the artists that were absolute winners were: "Zimbo Trio" (Rubens Barsotti 'Rubinho', Luiz Chaves and Amilton Godoy), Elis Regina, Wilson Simonal, Maria Bethania, in the Bossa Nova field; Altamar Dutra, as a romantic ballad chanter; and Roberto Carlos, in the so-called teen music. The labels who had these artists under contract—RGE, Phillips, Odeon, RCA and CBS—were also and always present in the first spots of the local charts. But, other names appeared in the highlights during the past twelve months, like Marcos Valle, Nara Leao, "Os Cariocas," "Quarteto Em Cy," "Renato & Seus Blue Caps," "Tamba Trio," "Demonios Da Garoa," "Sambalanco Trio," "Os Bossa 3," Walter Wanderley, Eumir Deodato, Geraldo Vandré, etc. Not to forget the all-time favorites, that are still going strong, like Elisete Cardoso and Helena De Lima, Miltoninho, Ciro Monteiro, Angela Maria, Luiz Bonfá, Paulinho Nogueira, etc. and composers like Antonio Carlos Jobim, who in spite of being absent in the US for long, has maybe the most part of his compositions among the most played,

together with Edu Lobo, Ze Kets Memescal, Vinicius De Moraes, etc. on the country, during the past twelve months, with more or less success, but always stirring the curiosity of the many fans that always attended their personal appearances. Other facts occurred, which marked each month of the 12 that went by. In August, the American Beatles (Roulette) disappointed the public, spoiled by the publicity of the original The Beatles; Miltoninho on the hit parades of Venezuela; Paul Winter and John N. Vincent, visited Brazil; Sergio Mendes and His Bossario on tour in Japan; Robert Nissen was also in this country. In September, the French singing star Francoise Hardy (Mocambo) was on a successful tour in Rio and Sao Paulo; Eva Garza (Odeon), of Mexico, also here then. October was the month when the death of two composers dear to Brazil, appeared in the news—Cole Porter and Antonio Maria! Another group, "Os Incríveis" (formerly "The Clevers") are in Europe on a successful tour, connected with Italian little queen Rita Pavone; the Barclay label appeared on the market through the local new representative RGE. November was Trini Lopez month: one day in Rio, one in Sao Paulo, were enough to put him on the top here, recordwise (Reprise, through Odeon); Eric Skinner appointed new Gen. Mng. of RCA Records Division; Alain Trossat takes over the Philips management; show "Bossa No Paramount" produced by Walter Silva, scores tremendous hit for the MPM; at Teatro Record, we had the pleasure to see beautiful Carmen Sevilla and composer husband Augusto Alguero; then Italian songster Gino Paoli followed the international shows; Louis Coultolenc Jr. of RCA visited the Brazilian firm, coming from the Mexico City offices. Last month of the year, December, brings the first noticeable activity for the coming Carnival; news from the USA (Continued on page 89)

All the Latin American and International Hits

come from

FERMATA

BRASIL

E. Lebendiger
Ave. Ipiranga 1123
San Paulo

ARGENTINA

M. S. Brenner
San Martin 640
Buenos Aires

MEXICO

M. Freidberg
Division Del Norte 31
Mexico City

BRAZIL—The Past 12 Months

Continued from page 88)

ring the successes of Brazilian artists on tour there—starting with Antonio Carlos "Tom" Jobim, followed by Carlos Lyra, Luiz Bonfá, Jorge Ben, Sergio Mendes, Rosinha De Valença, Wanda De Sah, Caetano Zama, and also Bola Sete—others are planning on coming soon. In January, with the beginning of the year, news keeps on pouring in, about changes in the organization and top staff of several of the important companies here—complete renewal announced by Musidisc, Mocambo and Continental, become actual; the figures of the Christmas sales bring their rewarding results to the recording companies. International US star of the many songs Connie Francis is in Brazil in February—with her as her manager George Scheck, conductor Joe Mazzu, drummer Bob Grauso and Connie's parents—a hit at the "Teatro Republica" for its opening; Palito Ortega was also in town, coming from Argentina. March is here: two news connected with RGE label appear—the visit of Eddy Barclay and friends and the final decision of the merging of the two labels RGE and Fermata—Enrique Lebendiger is now top man of both, while Marco Nobili and Julio Nagib are busy reorganizing the first of the labels, acquired by the second. Comes April with the revisit of another Italian singing star and composer of hits, Edoardo Vianello, at Teatro Record, Philips held its International Convention in Rio de Janeiro, with representatives from Venezuela, Chile, Argentina, Mexico, Columbia and Peru, giving prestige to the host's business; the start is given to the "First National Brazilian Festival of Popular Music." . . . It is to be held in three phases and the first proves already that, as told before, in spite of misorganization of beginning, it will be a public success, thanks to the promoters, not the producers. . . . In May, a tiny little big favorite returns to her field of victory—Rita Pavone is back in Brazil, and repeats her success; ends the "First Festival of Pop Music," consecrating Edu Lobo and Vinicius De Moraes as composers and Elis Regina as interpreter and, most of all, the present trend of the local music; Walter Silva has a new successful show at the Teatro Paramount; the US lyricist and rep of Tom Jobim comes to Rio de Janeiro, and takes back Dorival Caymmi for the "Andy Williams Show"; the best ambassadors of Brazilian MPM go to Lima, Peru and score a terrific success—"Zimbo Trio" and Elis Regina! June is a quieter month and the arrangements for the Celebrations of the 50th Anniversary of old-timer,

all-time favorite chanter Silvio Caldas, become headlines in Brazil. The last of the twelve months, July, was a busier one, with news of the personal appearances in Brazil of many international (mostly from the USA) entertaining stars — Tommy Dorsey and His Orchestra, the Pied Pipers, Frank Sinatra Junior, and then Johnny Mathis—who all could go back home, saying that Brazil is still one of the most appreciative countries for the US musicians and singers.

We are always somehow sorry that we cannot go into more detail about all the very much that is going on in Brazil about the music, the record and publishing industries, the artists of a country like Brazil, where one has the feeling that, if it wasn't for all the political and economical complications that seem endless, this would become easily number one pre-occupation of a great part of its inhabitants.

Last but not least, we have to consider the importance of the Brazilian Popular Music in the international field, during the past twelve years. Several artists conquered new markets in Europe, specially through the carefully planned music embassy, sponsored by a textile firm, which featured Wilson Simonal, the showman, Marly Tavares, the dancer, Luiz Carlos Vinhas and Combo (Octavio Bailly Jr. and Edson Machado), with Raulzinho on trombone, and rhythmists, Jorginho Arenas and Rubens Bassini; they were in Portugal, Spain, Italy, France and Italy, one hit after the other. Even Páree had a very good ambassador of MPM for quite a while, competing with so many artists from all the world and doing well—Carlos Lyra. Sergio Mendes went to Japan on tour, Maysa still in Madrid, Spain, gaining adepts for Brazilian music. In Lisbon, Portugal, Francisco Egydio, and several other Brazilian artists even unknown in their country, take advantage of having the same language, to score new musical victories—so much so that it is reflecting in the programming of the local only TV and all radio stations. Latin America was also haunted by the fascinating rhythm of Brazilian music but, probably the biggest victory was obtained by Zimbo Trio and Elis Regina in Lima, Peru, where they had the opportunity to prove how international their art is. While such artists await the chance to go to the U.S.A., the most important field for future victories, because of the enormous market it represents and the obvious leadership in international promotion, others are establishing slowly but surely a solid position for Brazilian Popular Music

in that country: while Joao Gilberto took definite care of New York, ex-wife Astrud tours the whole country and goes even into Mexico, scoring success after success (her album was on and off the charts lately), and Luiz Bonta appears in important TV programs like Nightlife of New York, when he is not recording or appearing in person here and there, Antonio Carlos "Tom" Jobim, is a must in all that deals with Brazilian music in the West Coast—appearing twice on Andy Williams Show, producing and cutting albums, composing special music for films and others—always sided by Ray Gilbert, who also managed to take all-timer Dorival Caymmi to the US, where he appeared in the same show. However, these were not the only exports of Brazilian music to the US—Eliane Pitman was in the Jack Paar Show, Jorge Ben, Rosinha De Valença, Sergio Mendes and Combo, Wanda De Sah, etc. were appearing in person and cutting waxes. And still another group of artists who are now residing in the US are promoting the

music of their country, like Bola Sete, Ze Carioca and Laurindo De Almeida in California, Vera Lucia "Valucha" Murgel De Castro in Chicago and Caetano Zama in New York, and still many ignored ones who cannot deny the strength of Brazilian music in their blood. But, also North American artists have given credit to the new Brazilian music; about Andy Williams all is said; Tony Bennett, in his last released album, not only sang two Brazilian numbers, but he also named the LP for one of them "Songs For The Jet Set" (Samba do Aviao); Tony Martin, also appears in several shows singing "The Girl From Ipanema" as a sort of team song; Connie Francis sings the Brazilian songs she learned in her last tour in Brazil (Deixa Isso Pra La); not to talk about the 50 or more recordings in the US of "The Girl From Ipanema" and some more of other numbers which are current hits in that country. The door is open. . . . Now, let's just step in!

EDITORA DE MUSICA BRASILEIRA E INTERNACIONAL S/A "E.M.B.I."

Rio de Janeiro — Brasil

Associated to the Southern-Peer group of New York

SOME OF OUR INTERNATIONAL SUCCESSES:

JORGE BEN

mos que nodo—por couso de voce menino—chove chuva—bicho da moto balango pemo—vem moreno vem—é só sombor—roso menino roso quero esquecer voce—volo uololo—o tomba—menino bonito noo choro etc. . . .

ARY BARROSO

é luxo só.

VINICIUS DE MORAIS

borquinho borquinho—conçoo de nós dois.

LUIZ BONFÁ

tristeço—conçoo do mor.

CARLOS LYRA

morio ninguém—borquinho de popel—quando chegores—menino—ciúme só mesmo por omor—sem soudode de voce—etc. . . .

JOAO MELLO

fim dom dom—sergipinho—dói . . . dói—gostasa é sombor—jogado fara espera par voce—gingo do muloto—vou de sombo com voce—xim xim de golinho—vai sofrer voi choror—etc. . . .

BRAZIL—RECORD COMPANIES

AUDIO FIDELITY DO BRASIL LTDA.
(Sebastiao Bastos, Luiz Mocarzel)
Rua Rego Freitas, 354—Sao Paulo
Audio-Fidelity

CBS DO BRASIL S. A., INDUSTRIA E COMERCIO
(Evandro Ribeiro, A. Silva, Othon Russo, Enilson Lins)
Rua Visconde Rio Branco, 53—Rio de Janeiro
Avenida da Liberdade—Sao Paulo
Columbia

COMPANHIA BRASILEIRA DE DISCOS
(Alain Trossat, Joao Araujo, Joaquim, Mario Duarte)
Avenida Rio Branco, 311—Rio de Janeiro
Rua General J. M. Salgado, 331—Sao Paulo
Philips, Sinter, Polydor, Decca, Westminster, Fonit, ABC, Paramount, Vanguard, Mercury

DISCOS CHANTECLER (Cassio Muniz S.A.)
(J. Rahmi, Braz Bacarin, Basilio Alves)
Rua Aurora, 1050—Sao Paulo
Avenida Rio Branco, 185—Rio de Janeiro
Chantecler, Ricordi, Marfer, Fuentes, Peerless, Roulette, Disk Luckey S.R.L., Sica Peruana, Edward Radio

DISCOS ELENCO
(Aloysio de Oliveira)
Avenida Rio Branco, 128—Rio de Janeiro
Elenco

FABRICA DE DISCOS ROZEMBLIT, LTDA.
(Kurt Sonderman, Adolfo Rozemblit, Jairo Rodrigues)
Estrada dos Remedios, 855—Recife
Rua Conselheiro Nebias, 662—Sao Paulo
Avenida Rio Branco, 14—Rio de Janeiro
Mocambo, Gurtler, Blue Bell

FERMATA DO BRASIL, LTDA.
(Enrique Lebendiger, Juvenal Fernandes)
Avenida Ipiranga, 1123—Sao Paulo
Fermata, Cameo, Parkway, Jupiter, Premier, Atco, Durium, Tamla/Motown

DISCOS FARROUPILHA LTDA.
(Tasso Bangel, Danilo de Castro)
Rua Barao de Itapetinga, 120—Sao Paulo
Farroupilha

GRAVACOES ELETRICAS S. A.
(Savio Carvalho Silveira, Bighton Neto, M. Campodarvi, Alfredo Corleto)
Avenida do Estado, 4667—Sao Paulo
Rua Pedro Lessa, 35—Rio de Janeiro
Continental, Kapp, Colpix, W&G's, Caboclo, Ducretet-Thomson, Sertanejo, Telefunken, Disquinho

GRAVACOES MUSIDISC LTDA.
(Nilo Sergio Pinto)
Rua da Lapa, 120—Rio de Janeiro
Musidisc, Nilser, United Artists, Command, Masterpiece, Vox, Audiola, Audio-Laboratory, Hi-Fi Jazz, Grand Award, Junior

INDUSTRIAS ELETRICAS & MUSICAIS FABRICAS ODEON S.A.
(Harold Morris, Henry Jessen, Oswaldo Gurzoni)
Avenida Rio Branco, 99—Rio de Janeiro
Rua Bento Freitas, 362—Sao Paulo
Odeon, Capitol, Warner Bros./Reprise, London, Angel, Imperial, Orion

RCA ELETRONICA BRASILEIRA S.A.
(Douglas Reid, E. Skinner, C. Nobili, Ramalho Neto, Paulo Rocco)
Avenida Ipiranga, 1097—Sao Paulo
Rua Visconde da Gavea, 125—Rio de Janeiro
RCA Victor, Camden, Liberty

RGE DISCOS LTDA.
(Enrique Lebendiger, Marcos Nobili, Julio Nagib)
Avenida Ipiranga, 1123—Sao Paulo
RGE, CGD, Barclay, Dot, Orfeon

SOM INDUSTRIA & COMERCIO S.A.
(Emilio Vitale, Nazareno de Brito, Neusa Machado da Costa)
Rua Casper Libero, 58—Sao Paulo
Avenida Rio Branco, 25—Rio de Janeiro
Copacabana, MGM/Verve, Hi-Fi Record, Pallette, Montilla, Audiomec

FÁBRICA DE DISCOS

Rozemblit LTDA

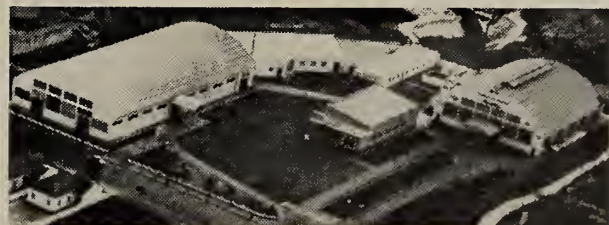

MOCAMBO
MOCAMBO
MOCAMBO
MOCAMBO
MOCAMBO

The best installed plant in Brazil with its own recording studio, graphic shops, record covers manufacturing, galvanoplasty works, vinyl tablets mill and—24 record presses.

Distributors of American and European labels:

KAPP, SEECO, TIME, JAY-GEE,
VOGUE, SIDET, MEAZZI, SURF,
SUPRAPHON ITALDISC, ITALMUSIC.

Main office
and factory:

**Estrada dos Remedios, 855
RECIFE, Brazil
Tel. MOCAMBODISCOS**

Branches:

**Av. Rio Branco, 14-15th floor
RIO DE JANEIRO**

**Rua Conselheiro Nébias, 662
SÃO PAULO.**

BRAZIL—Publishers

RIO DE JANEIRO
CASA CARLOS WEHRS PIANOS S.A.
Rua da Carioca, 47

CRUZEIRO MUSICAL
Rua Visconde de Inhauma, 134

EDICOES EUTERPE LTDA.
Avenida Rio Branco, 108

EDICOES MANGIONE LTDA.
Rua 13 de Maio, 13

EDICOES SAMBA
Rua Selva, 70 (Usina-Tijuca)

EDITORIA ARTUR NAPOLEAO LTDA.
Rua Juan Pablo Duarte, 46

EDITORIA DE MUSICA BRASILEIRA & INTERNACIONAL LTDA.
Avenida Almirante Barroso, 91

EDITORIA MUSICAL BRASILEIRA
Rua Santa Luzia, 799

EDITORIA MUSICAL PAO DE ACUCAR LTDA.
Rua Rosa Silva, 18

EDITORIA NOSSA TERRA
Rua Visconde de Inhauma, 134

A GUITARRA DE PRATA INSTRUMENTOS DE MUSICA LTDA.
Rua da Carioca, 37

RIO MUSICAL LTDA.
Rua Visconde de Inhauma, 134

TODAMERICA
Rua Santa Luzia, 799

SAO PAULO
ABERBACH EDITORA MUSICAL LTDA.
Avenida Ipiranga, 1123

BANDEIRANTE EDITORA MUSICAL
Rua do Seminario, 165

EDITORIA DE SUCESSOS INTERNACIONAIS
Avenida Ipiranga, 1123

EDITORIA MUSICAL ARAPUA
Avenida Ipiranga, 1123

EDITORIA MUSICAL BROADWAY LTDA.
Avenida Ipiranga, 1123

EDITORIA MUSICAL CARLOS GOMES LTDA.
Rua 24 de Maio, 476

EDITORIA MUSICAL ESSEX LTDA.
Avenida Ipiranga, 1123

EDITORIA MUSICAL FRANK LTDA.
Avenida Ipiranga, 1123

EDITORIA MUSICAL KASSNER LTDA.
Avenida Ipiranga, 1123

EDITORIA MUSICAL MILLS LTDA.
Avenida Ipiranga, 1123

EDITORIA MUSICAL SANTOS DUMONT LTDA.
Rua 24 de Maio, 476

EDITORIA MUSICAL WALDEN LTDA.
Avenida Ipiranga, 1123

FERMATA DO BRASIL LTDA.
Avenida Ipiranga, 1123

IRMAOS VITALE S.A. INDUSTRIA & COMERCIO
Rua Franca Pinto, 42

MELODIAS AMERICANAS LTDA.
Avenida Ipiranga, 1123

MUSIBRAS EDITORA MUSICAL
Avenida Ipiranga, 1123

MUSICAS & INSTRUMENTAIS CASA MANON S.A.
Rua 24 de Maio, 476

MYERS EDITORA MUSICAL LTDA.
Avenida Ipiranga, 1123

NOTAS MAGICAS EDITORA MUSICAL LTDA.
Avenida Ipiranga, 1123

EDICOES MUSICAIS RCA LTDA.
Avenida Ipiranga, 1097

EDICOES MUSICAIS VICTOR LTDA.
Avenida Ipiranga, 1097

RICORDI BRASILEIRA S.A.
Rua Quintino Bocaiuva, 22

ROBERT MELLIN LTDA.
Avenida Ipiranga, 1123

SAM FOX EDITORA MUSICAL LTDA.
Avenida Ipiranga, 1123

SERESTA EDICOES MUSICAIS
Avenida Ipiranga, 1123—S.P.

SMART EDITORA MUSICAL LTDA.
Avenida Ipiranga, 1123—S.P.

BRAZIL—THE PAST TWELVE MONTHS—BEST SELLERS

- *1. DATEMI UN MARTELLO—(Fermata) Rita Pavone/RCA Victor
- *2. DEIXA ISSO PR'A LA—(Todamerica) Jair Rodrigues/CBD (Philips)
- *3. AMORE SCUSAMI—(Fermata) John Foster/Fermata
- *4. PERFIIDIA—(Vitale) Trini Lopez/Reprise
- *5. MICHAEL—(Notas Magicas) Trini Lopez/Reprise
- *6. MY BOY LOLLIPOP—(Vitale) Millie Small/CBD (Philips)
- *7. OFERENDA—(Nossa Terra) Altamar Dutra/Odeon
- * SE PIANGI SE RIDI—(Fermata) Bobby Solo/Chantecler (Ricordi)
- * CARCARA—(np) Maria Bethania/RCA Victor
- * ARRASTAO—(.) Elis Regina/CBD (Philips)
11. UNA LACRIMA SUL VISO—(Notas Magicas) Bobby Solo/Chantecler (Ricordi)
12. CIN CIN—(Embi) Richard Anthony/Odeon
13. O TREM DAS ONZE—(Vitale) Demonios da Garoa/Chantecler
14. QUE QUERES TU DE MIM—(Mundo Musical) Altamar Dutra/Odeon
15. THE HOUSE OF THE RISING SUN—(Fermata) The Animals/Odeon
16. SEPARACAO—(Edicoes RCA) Claudio de Barros/RCA Victor
17. SOMOS IGUAIS—(Mundo Musical) Altamar Dutra/Odeon
18. SCRIVI—(Edicoes RCA) Rita Pavone/RCA Victor
19. SUL CUCUZZOLO—(Fermata) Rita Pavone/RCA Victor
20. PRESTE ATENCAO—(Vitale) Giane/Chantecler
21. La Bamba—(Embi) Prini Lorez/RGE
22. FROM RUSSIA WITH LOVE—(Fermata) Matt Monro/Odeon
23. MENINO DAS LARANJAS—(Fermata) Elis Regina/CBD (Philips)
24. OBSESSAO—(Embi) Sergio Odilon/CBS
25. BAILE DA SAUDADE—(Vitale) Francisco Petronio/Continental

* numbers that reached #1 spot

BRAZIL—THE PAST TWELVE MONTHS—TOP LP'S

- *1. MEUS 18 ANOS—Rita Pavone/RCA Victor
- *2. O FINO DA BOSSA—Several Brazilian Artists (live)/RGE
- *3. THE LATIN ALBUM—Trini Lopez/Reprise
- *4. SAMBA, EU CANTO ASSIM—Elis Regina/CBD (Philips)
- * OS REIS DO YE, YE, YE—The Beatles/Odeon
6. ZIMBO TRIO—Zimbo Trio/RGE
7. THE BEATLES AGAIN—The Beatles/Odeon
8. 'S LOVELY—Ray Conniff/CBS
9. 'S YOUNG—Ray Conniff/CBS
10. QUE QUERES TU DE MIM—Altamar Dutra/Odeon
11. GIOVENTU—Several Italian Artists/RCA Victor
12. SENTIMENTAL DEMAIS—Altamar Dutra/Odeon
13. BEATLEMANIA—The Beatles/Odeon
14. E PROIBIDO FUMAR—Roberto Carlos/CBS
15. A BOSSA NO PARAMOUNT—Several Brazilian Artists (live)/RGE
16. TRINI LOPEZ AT PJ'S—Trini Lopez/Reprise
17. A NOVA DIMENSAO DO SAMBA—Wilson Simonal/Odeon
18. O TREM DAS ONZE—Demonios da Garoa/Chantecler
19. NELSON SEMPRE NELSON—Nelson Gonçalves/RCA Victor
20. SAMBALANCO TRIO—Sambalanco Trio/Audio Fidelity
21. ROBERTO CARLOS CANTA PARA A JUVENTUDE—Roberto Carlos/CBS
22. O BAILE DA SAUDADE—Francisco Petronio/Continental
23. OPINIAO—Nara Leao/CBD (Philips)
24. AMOR—Eydie Gorme and Trio Los Panchos/CBS
25. TAMBA TRIO—Tamba Trio/CBD (Philips)

* albums that reached #1. spot

WORLD WIDE MUSIC TRADE DIRECTORY

(Continued from page 86)

NEW ZEALAND

MUSIC PUBLISHERS

BELCAS MUSIC LTD.—P.O. Box 296—WELLINGTON (162-172 Wakefield Street—Wellington)
Phone: 54-890
Cable: GRAMOPHONE WELLINGTON
Mgr.: Mr. F. W. Smith

CHARLES BEGG & CO., LTD.—P.O. Box 889—DUNEDIN (143 Princess Street—Dunedin)
Phone: 79-350
Cable: MANUKA DUNEDIN
Gen. Mgr.: Mr. T. R. Gobby

J. ALBERT & SON PTY., LTD.—2-4 Willis Street—WELLINGTON
Phone: 41-926
Cable: BOOMERANG WELLINGTON
Mgr.: Mr. G. P. O'Sullivan
Head office: 139 King Street, Sydney, NSW, Australia

MUSICAL IMPORT CO., LTD.—P.O. Box 2848—WELLINGTON (19-21 Manners Street—Wellington)
Phone: 40-123, 40-124
Cable: MUSICO WELLINGTON
Mgr.: Mr. J. K. Begg

SANDY MUSIC CO., PTY., LTD.—P.O. Box 1431—WELLINGTON (31 Harris Street—Wellington)
Phone: 43-888
Cable: VIKING WELLINGTON
Man. Dir.: Mr. Murdoch Riley

SEVEN SEAS PUBLISHING CO., PTY., LTD.—P.O. Box 1431—WELLINGTON (31 Harris Street—Wellington)
Phone: 43-888
Cable: VIKING WELLINGTON
Man. Dir.: Mr. Murdoch Riley

SOUTHERN MUSIC PUBLISHING CO. (N.Z.) LTD.—P.O. Box 656—AUCKLAND C.T. (201 Pacific Building—Wellesley Street—Auckland)
Phone: 23-851
Cable: SOUTHMUSIC AUCKLAND
Mgr.: Mr. Warwick Ransom

RECORD MFRS

ALLIED INTERNATIONAL RECORDS LTD.—P.O. Box 3043—AUCKLAND (N.I.M.U. Building—O'Connell Street—Auckland)
Phone: 21-949
Cable: GROOVE AUCKLAND
Labels (domestic): Allied International
Labels (others): Embassy, Oriole, Stereodiddies, United Artists, Verve.

HIS MASTER'S VOICE (NEW ZEALAND) LTD.—P.O. Box 296—WELLINGTON (162-172 Wakefield Street—Wellington)
Phone: 54-890
Cable: GRAMOPHONE WELLINGTON
Pres.: Mr. A. J. Wyness
Labels (domestic): Columbia, His Master's Voice, Parlophone
Labels (others): Capitol, Decca, Liberty, London, M.G.M., Warner Bros.

PEAK RECORDS LTD.—P.O. Box 1757—CHRISTCHURCH (76 Chester Street—Christchurch)
Phone: 88-832
Cable: HITDISC CHRISTCHURCH
Pres.: Mr. Jack Urlwin
Labels (domestic): Peak
Labels (others): Cadence, Cimarron, C.I.R.C.A., Delta, Duke, Ember, Jabar, Kash, King, Meladisc, Oriole, Prima Magnagroove, Saga, Sue, Tifco

PHILIPS RECORDS (N.Z.) LTD.—P.O. Box 3517—WELLINGTON (181-195 Wakefield Street—Wellington)
Phone: 56-115
Cable: ARGENTA WELLINGTON
Gen. Mgr.: Mr. J. G. Broughton
Labels (domestic): Philips
Labels (others): Caedmon, CBS, Coronet, Fontana, Kapp, Mercury, Polydor, Riverside, Sceptre, Wand.

PYE LTD.—P.O. Box 2839—AUCKLAND (O'Connell Street—Auckland)
Phone: 21-949
Cable: PYRAD AUCKLAND
Labels (domestic): Pye
Labels (others): Colpix, Golden Groove.

RADIO CORPORATION OF NEW ZEALAND LTD.—P.O. Box 3044—AUCKLAND (O'Connell Street—Auckland)
Phone: 21-949
Cable: MARKSLIM AUCKLAND
Labels (domestic): Tanza
Labels (others): RCA Camden, RCA Victor, RCA Victor

RECORD DISTRIBUTING CO. OF NEW ZEALAND.—P.O. Box 86—LEVIN (377 Oxford Street—Levin)
Phone: 5879
Pres.: Mr. W. L. Clark
Labels (domestic): Mark, Minex, Tala
Labels (others): Alki, Buddy, Duel, Flo-Jo, Pharaoh Sarg.

RECORD MANUFACTURERS & DISTRIBUTORS LTD.—P.O. Box 3534—AUCKLAND (85 Lorne Street—Auckland)
Phone: 23-094
Cable: ONSTAGE AUCKLAND
Pres.: Mr. Harry M. Miller
Labels (domestic): La Gloria
Labels (others): Audio Fidelity, Ballet in Education, Cameo/Parkway, Reprise, Roulette, Seeco.

SACRED RECORD (N.Z.) LTD.—P.O. Box 275—LEVIN (564 Oxford Street—Levin)
Phone: 4005
Cable: SACORDS LEVIN
Pres.: Mr. Peter R. Harris
Labels (domestic): Sacred
Labels (others): Word

VIKING RECORD CO., LTD.—P.O. Box 1431—WELLINGTON (31 Harris Street—Wellington)
Phone: 43-888
Cable: VIKING WELLINGTON
Man. Dir.: Mr. Murdoch Riley
Labels (domestic): Pacific, Viking
Labels (others): Argo, Ava, Briar, Canadian-American, Cannon, Chancellor, Chateau, Chess, Congress, Golden, Meazzi, P.P.X., Quality, Roac Schofield Productions, Sonet, Tahiti, Tartan, Vego Waverly.

G. A. WOOLLER & CO., LTD.—P.O. Box 2167—AUCKLAND (N.I.M.U. Building—O'Connell Street—Auckland)
Phone: 21-949
Cable: FIVESTAR AUCKLAND
Labels (domestic): Stebbing, Zodiac
Labels (others): AmPar, Atlantic, Brunswick, Command, Coral, Decca (USA), Festival, Grand Award Impulse, 20th Century Fox, Vox, Westminster.

NICARAGUA

RECORD MFRS

AGUERRI & HURTADO CIA., LTDA.—Apartado 85 MANAGUA D.N. (3^a Calle Nor-Este No 312—Managua D.N.)
Phone: 4506
Cable: AGUERRI MANAGUANIC
Pres.: Mr. Juan Aguerrri Jr.
Labels (domestic): Carynel, Masaya, Nicaragua
Labels (others): ABC-Paramount, America, Angel Atlantic, Audiomex, Barclay, Capitol, Chancellor, Cisne, Colonial, Colpix, Coral, Coro, Decca, De Norte, Dimsa, Eco, Falcon, Hit, Kapp, Kismet, London, Maya, Mercury, Metropolitan, Montilla, Orfeon, Raso, Sonus, Tikal.
SOLORZANO VILLA PEREIRA COMERCIAL S.A.—Apartado 481—MANAGUA D.N. (Avenida Roosevelt 202—Managua D.N.)
Phone: 3501 to 3504
Cable: SOVIPE MANAGUANIC
Pres.: Mr. Enrique Pereira A.
Labels (domestic): Dario, Lamm, Lanusac
Labels (others): Columbia, Compass, Dot, Gamma Gema, M.G.M., Musari, Peerless, RCA Victor, Roble, Seeco, Tizoc, etc.

NIGERIA

RECORD MFRS

BADEJO STORES—P.O. Box 361—LAGOS (5 Olorogun Street—Lagos)
Phone: 20640, 20997
Cable: BASTORES LAGOS
Pres.: Mr. E. Badejo-Okusanya
Labels (domestic): Badejo's Sound Studios
Labels (others): Distributing the records from Phillip (Nigerian) Ltd.

DECCA (WEST AFRICA) LTD.—P.O. Box 412—LAGOS (26 Abibu-Oki Street—Lagos)
Phone: 25396
Cable: DECCAWA LAGOS
Pres.: Sir Edward Lewis
Labels (domestic): Decca West Africa
Labels (others): Ace of Clubs, Ace of Hearts, Bellona, Brunswick, Coral, Decca, Felsted, London, L'Oiseau-Lyre, RCA, RCA-Camden, RCA-Victrola, Telefunken, Warner Bros.

(Continued on page 104)

BRAZIL—THE PAST TWELVE MONTHS—TOP DOUBLE-COMPACTS

- *1. ADORABLE—Rita Pavone/RCA Victor
- *2. ALTEMAR DUTRA No. 2—Altamar Dutra/Odeon
- *3. TWIST AND SHOUT—The Beatles/Odeon
- *4. O CALHAMBEQUE—Roberto Carlos/CBS
- *5. THE BEATLES—The Beatles/Odeon
- * RITA PAVONE—Rita Pavone/RCA Victor
- * A HARD DAY'S NIGHT—The Beatles/Odeon
8. QUERO-ME CASAR CONTIGO—Roberto Carlos/CBS
9. 'S YOUNG—Ray Conniff/CBS
10. SINFONIA DOS CANARIOS—Canary Birds rec by J. D. Frisch/Copacabana
11. SENSACIONALE—Rita Pavone/RCA Victor
12. AMOR—Eydie Gorme and Trio Los Panchos/CBS
13. CALMO SETEMBRO—Moacyr Franco/Copacabana
14. ANNA MARIA—Sergio Endrigo/RCA Victor
15. CARLOS ALBERTO—Carlos Alberto/CBS
16. LA ITALIANA—Connie Francis/MGM (Copacabana)
17. E FACIL SER FELIZ—Moacyr Franco/Copacabana
18. QUERIA—Carlos Jose/CBS
19. FRENTE AO MAR—Agnaldo Rayol/Copacabana
20. O RITMO DA CHUVA—Demetrius/Continental

* double-compact records that reached #1. spot



Andy Stewart



Cliff Richard



The Dave Clark Five



The Yardbirds

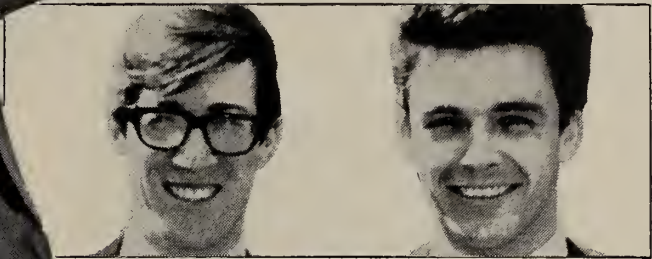

The Shadows

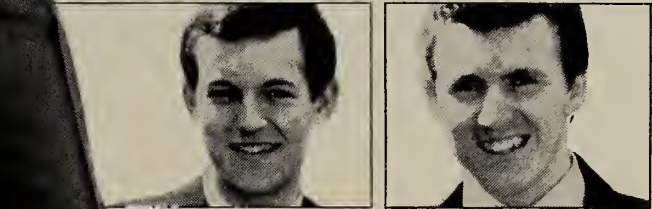

Rolf Harris

EPIC HAS PROVEN THAT MUSIC IS THE INTERNATIONAL LANGUAGE. WE GRATEFULLY ACKNOWLEDGE THESE OUTSTANDING ARTISTS AND THEIR CONTRIBUTION TO THE GROWTH OF OUR LABEL.



The Fastest Growing Name in Recorded Entertainment

SWITZERLAND—The Past 12 Months

Switzerland, as always, remains an importing market and business over the past twelve months has been generally stable. Essentially an E.P. and L.P. market the year has seen a steady increase in album sales which off-sets the slight drop in single sales. It is estimated that total cash sales are made up of 40 per cent L.P.s; 40 per cent E.P.s; and 20 per cent singles. Since October 1964 all stereo records have been selling at the same price as mono whilst the price of E.P.s has been raised to 7.90 francs. Switzerland has three official languages, German in the northern, eastern and central areas (Zurich, Basle and Berne); French in the West (Geneva and Lausanne) and Italian in the South.

Of Switzerland's 5½ million population the German section, with approximately 4 million, has the largest sales potential although the biggest buyers are reported to be in the French speaking section which accounts for about one million people. Singles sell better in the German section whilst in the West, as in France itself, it is an E.P. market. Everywhere, jazz and the classics corner the L.P. market with pop albums by top artistes healthily increasing. In the pop singles field 30,000 constitutes a solid hit for a French, German or Italian record but a really major international hit, popular in all three territories, can notch up 100,000. Local Swiss recordings of popular music sell well, particularly folk music from Swiss-German regions. These recordings find a ready market both with the Swiss and with the tourists. Home sales generally have been boosted in recent years by the vast influx of over 800,000 'guest workers' from Italy, Germany, Greece and Spain etc. who have maintained their link with home by buying records by popular artistes of their respective countries. However, certain restrictive measures introduced by the Swiss Government in recent months may well bring about a drop in the volume of sales during the coming months. The Government has ordered a reduction in foreign labour of 10 per cent during 1965 which will mean about 70,000 people, mostly Italians, leaving the country. At the same time restrictions were also introduced regarding credits and construction in order to bring the present economic boom under control. The departure of so many record buyers is bound to affect sales—particularly the Italian repertoire.

Switzerland, like Italy, is very festival conscious and there are several annual music festivals which attract artistes and visitors from all over the world. Perhaps the most important of these is the Swiss Jazz Festival which takes place at Zurich every September with the finest jazz musicians from all over Europe taking part. Zurich is also the scene of two other annual events—Folk Music Festival and the Festival Bela Canzone Italiano. For the latter Italian artistes come to Zurich to present new and hitherto unrecorded and unpublished songs. Major classical festivals also take place in Zurich, Lausanne and Montreaux. Although no official sales figures are ever issued for Switzerland and sales are reported to be steady, several manufacturers have expressed concern at the number of black market imported records which find their way into the country and are subsequently sold at discount prices. Nevertheless it has been a pretty good year for the record companies and music publishers. Musikvertrieb A.G. of Zurich headed by Maurice Rosengarten maintain their leading position in the industry and report a year of resounding success in sales in all categories and speeds. During the year they have added Triola to the strong list of labels they carry and have enjoyed considerable success with artistes of all nationalities. One of the best selling American artistes was Roy Orbison who further enhanced his reputation in Switzerland, his biggest hit being "Oh Pretty Woman" which topped the Swiss charts for many weeks. Presley maintained his pop-

ularity with his early records still as much in demand as his latest hits. Paul Anka won many new friends by his European tour and TV shows. His recordings in German were particularly successful in Switzerland.

The Beach Boys also enjoyed chart status with titles such as "Little Honda" and "Dance, Dance, Dance." From Britain The Rolling Stones gathered tremendous sales for Musikvertrieb both in the single and L.P. fields. They were well up in the hit parade with "Not Fade Away"; "Time Is On My Side" and "Heart of Stone." German star Ronny was the big surprise in the hit parade stakes with three successive entries "Oh My Darling Caroline"; "Kenn Ein Land" and "Kleine Annabelle". Hildegard Kneff gave a new impetus to German ballads as witness the sales of her L.P.s whilst Rita Pavone, whether singing in Italian, French or German, was a constant best seller. Bobby Solo topped the charts with his San Remo dinner "Si Piangi Se Ride." Manuela achieved fame with her recording of "Schuld War Mur Der Bossa Nova" and the established favourite Vico Torriani made it with "Monsieur Chanson" and "Ski Twist" and is currently successfully touring with a musical. In the classical field Musikvertrieb had a sensational success with the RCA recording of Bizet's opera "Carmen" with Price-Freni-Corelli-Merrill conducted by Von Karajan. After a performance of Benjamin Britten's "War Requiem" in Switzerland demand for the outstanding recording of the work greatly increased. The new recording of "Matthaus Passion" was enthusiastically reviewed and received and recordings by bass Nicoli Ghiurov surpassed all sales expectations.

Mr. Hans Oestreicher of Turicaphon A.G. with the only pressing plant in Switzerland reports that the company maintained its annual production figure of approximately 3,000,000 records. They exhibited at the Basle Fair and during the year expanded their export market. Master tapes of their repertoire on the Elite Special label have been taken for pressing in many overseas territories including Canada, United States, South Africa, South America, Japan and Australia. Record wise their biggest success during the past twelve months was with Liverpool group Jimmy and The Rackets whose four singles "My Soul"; "Skinny Minny"; "Ten Little Indians" and "Only You" and one L.P. on Elite Special sold over 1,000,000 copies in Switzerland, Germany and Austria. The group's success is partly due to the fact that they have been performing continuously in these territories for over a year. They also make frequent TV appearances. From the Ricordi repertoire Turicaphon sold 50,000 copies of "Una Lacrima Sul Viso" and in two months sold 20,000 copies of "Se Piangi Se Ridi" both by Bobby Solo. The publishing rights for both titles are handled in Switzerland by Editions Flora. Other San Remo hits to sell well in Switzerland were "Abbracciami Forte" by Ornella Vanoni "Le Colline Sono In Fiore" by Wilma Goich and "Mia Cara" by Robertino whose first recordings in German "Luna Luna Luna" and "Arrivederci" were recently cut in Hamburg. Turicaphon's single sales were considerably up on the previous year and a still bigger increase is reported for their L.P. repertoire which now totals over 150 albums.

Philips Records report a satisfactory year with the biggest sales registered with their French repertoire particularly Sheila, Claude Francois, Johnny Hallyday, Nana Mouskouri and more recently France Gall who created a big demand in Switzerland for her Eurovision winner "Poupee De Cire". She also had a big success with "Sacre Charlemagne" which topped the Swiss charts. The Fontana special low-priced series of pop and classical 12" L.P.s have also sold well at 10.95 francs. As usual Philips have scored heavily with local folk recordings two big sellers in this category

(Continued on page 94)

JOHANNES FEHRING



Ohello - Die Walküre
Lohengrin



A ZÜNFTIGE MUSI

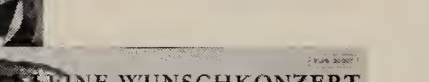

ECHOS FROM SWITZERLAND



ELINE WUNSCHKONZERT



Fröhliches Tyrol



ECHOS FROM SWITZERLAND

TABALKAPPELL MARIEN BERG

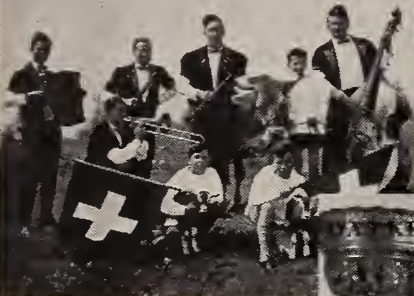

ELINE WUNSCHKONZERT

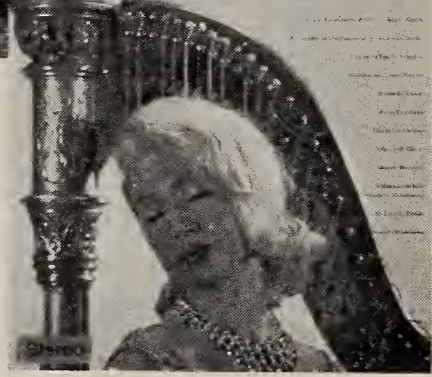

ELITE SPECIAL

The world famous label from the only Swiss record factory.

We have our own sales organization in

Germany — Austria — Switzerland

If you are not yet represented in any of these countries we can guarantee you top-class distribution for your label.

In addition to thousands of singles our repertoire includes more than 200 LP's with

Folk music from every country in Europe

Light music • Operettas • Operatic and classical music

If you are interested in taking up tapes from our repertoire or in distributing our records, please write to . . .

ELITE



SPECIAL

TURICAPHON AG, Schweizer Schallplattenfabrik,
8611 Riedikon/Uster, Switzerland
phone number: 87.43.11 telex Zurich 52.645



In Switzerland

The centre of the Record Industry is

MUSIKVERTRIEB AG

Zurich

DISTRIBUTING THE TOP LABELS
IN THE WORLD OF MUSIC

DECCA
TELEFUNKEN
RCA-VICTOR
LONDON
CAPITOL
WARNER BROS.
EURODISC

GALLERIA DEL CORSO
BARCLAY
ARIOLA
BEL-AIR
DUCRETET-THOMSON
L'OISEAU LYRE
ELITE-SPECIAL

FESTIVAL
HED-ARZI
MONUMENT
CAMEO PARKWAY
VEGA
RICORDI
TRIOLA

BADENERSTRASSE 555
ZURICH (SWITZERLAND)

Telephone: 051/ 54.97.54

Cable: Musikvertrieb Zurich

SWITZERLAND—The Past 12 Months

SWISS RECORD MANUFACTURERS

(Continued from page 92)

being "Harmonie Appenzell" and original Appenzellian music. Philips artiste Kapelle Della Torre also took first prize at this year's folk music contest in Zurich. The company was also happy to have the original Finnish Letkiss by Jaakko Losanen.

A major event of the EMMI A.G. year was their removal from Zurich to Zug. EMI is particularly strong on local production of Swiss repertoire i.e. folklore and children's records. In the latter category the company lays claim to something like 80 per cent of the total market. Releases are mainly E.P.s including about 60 titles by Trudi Gerster and D'Schlieremer childrens choir. Cabaret disks in Swiss-German by local artistes are also popular. EMI's biggest selling artistes in the pop field have been The Beatles, Cliff Richard, Richard Anthony, Gilbert Beaud and Adamo. EMI labels are distributed and promoted by Jecklin and Hug for Switzerland and in Austria by their own company, Austrian Columbia.

Jecklin & Co. of Zurich continues to enjoy considerable success with British artistes with The Beatles still leading the field although even their sales are down compared with the phenomenal figures of early 1964. Cliff Richard is still tremendously popular and the biggest and most consistent French seller is Enrico Macius. Mr. Hens Jecklin, reports that sales generally were slower than 12 months ago with nothing selling in the same quantities. He also noted that in the German section of Switzerland a good record would enjoy top sales for at least six months but the life of a hit record in the French section was appreciably shorter. During the year Jecklin added the Tamla Motown label to their distributive list. Their magnificently equipped record store (numerous private cubicles—sets of individual listening phones—clearly marked and arranged browser boxes etc.) is still unparalleled and another shop was opened in the autumn of 1964.

Phonag A.G. at Winterthur have, during the past year, further extended their representation with the acquisition of Epic, Okeh, Musicor (Gene Pitney is a big seller in Switzerland), Saba (German label), Style/Phonocolor, Qualibit (Austrian label) and Hickory. P.P. sales continue to expand and Phonog reports that stereo sales are getting better and better with sales for the first quarter of this passing all expectations.

As far as the SBC catalogue is concerned about 70 per cent of new release sales are stereo. A considerable number of CBS classical artistes have visited Switzerland during the year for concerts and festivals including Isaac Stern, Rudolf Serkin, Brailowsky, Casadeus, Eugene Ormandy and Francesatti. A number of jazzman too have appeared with success including Brubeck, Davis and Monk.

The Finsterwald and Cantacuzene, Vogue S.A. and Editions Belmont group of companies have enjoyed another year of success and progress.

Artistes from the Vogue roster have been particularly active in the Swiss Hit Parade—leading the field Petula Clark notably with "Downtown" whilst Francois Hardy also maintained her popularity. British group The Searchers also established themselves in the Swiss charts and once again Reprise artistes contributed handsomely to the company's success during the year.

Once again Siemens (Deutsche Grammophon) report considerable success with foreign artistes both American and continental. In Basle, Hug and Co. have had similar success with British and American artistes via releases on the HMV, Electrola and Liberty labels etc.

During the first six months of its existence the newly formed Pick label has issued 35 E.P.s and L.P.s ranging from pops to light classical. One of the most successful being "Happy Letkiss Party" by The Happy Letkiss Boys. Pick also release material in Switzerland of two German labels Storz (who release Pick in Germany) and Regina. Pick is also released in Japan by Peichiku Record Company of Tokio.

Editions Coda during the past year have had several major hits including "Vergangen," "Vergessen, Voruber" by top German star Freddy on Polydor. Other successful titles have included "Cowboy Vagabunden" by Peter and Su on Ariola; "Du, Du, Du Gehst Voruber" by Sussie on Vogue; "Kusse Nie Nach Mitternacht" by Siv Malmquist on Metronome; "Kiddy Kiddy Kiss Me" by Paul Anka and by Rita Pavone on RCA. "Rag Doll" by The Five Tops on Philips and Ma Vie by Alain Barriere on RCA.

Editions Helbling have also had a number of big sellers during the year both for themselves, Southern Music, Nova and World Music.

SUPPLIES AND SERVICES

Pressing Plants
Turicaphon AG.,
Schweizer Schallplattenfabrik,
8611 Riedikon/Uster.
Tel: 87 43 11 Telex: 52645

MUSIC LICENSING ASSOCIATIONS
SUISA (Societe Suisse des Auteurs et Editeurs)
General Guisan Quai 38, 8027 Zurich 27.
Tel: 25 77 00

RECORDING STUDIOS
Tonstudio Hug & Co.
Fusslistrasse 4, 8000 Zurich 1

Alfred Lussi
Disco-Ton Wettsteinalle 21, 4000 Basel

Max Lussi
Tonstudio, Leimenstrasse 76, 4000 Basel

Studio d'Enregistrement de Disques B.V.M.
32 rue de St-Jean, 1200 Geneve

W. A. Wettler
Bachtelstrasse 16, 8304 Wallisellen

Disques Office,

188 rue Pierre Aebly, 1700 Fribourg
Ades—Petit Menestral, Acropole, Angelicum, America (Musidisc), Bam (Boite a musique), Discophiles Francais—Alpha, Lumen Pleiade, Pacific—Orphee, President, Supradidac, Versailles, Supraphon

Electromusic AB,
Nauenstrasse 71, 400 Basel 2.
Tel (061) 34 92 50

Tell Record, Tempo, Osca, 777, Alpha, Cetra, Excelsius, Juke Box, Sabrina, Copacabana, Olympia, Newton, Omega, Ember-Record, Saef, Atrone, Tivoli

EX LIBRIS VERLAG A.G.

Kanzleistrasse 126, Zurich 4
Labels: Ex Libris, Pan
Distributors of: BBC London (English by Radio) Blue Note, Cotta Musikseminar, Harmonia, Musical Masterpiece Society

Finsterwald & Cantacuzene,

Avenue des Alpes 70, 1820 Montreux
Adventure, Arlequin, Belter, Cam (Durium), Canadian-American Records, Caroselle (Durium), Chancellor, Circus, Cochon d'Inde (Vogue), Contrepoint, Debut, Dixieland Jubilee, Dounia, Durium, Erato, Everest, Fiori Musicali, Gazell, Gene Norman, Golden Guinea (Pye), Jardin des Arts (Erato), Jazz Collector, Jazz Selection, Kangourou (Vogue), King Hazz, Majestic, Mode, Nixa, Orfeon, Pastorale et Musique, Piccadilly, Pingouin (Vogue), Pop, Pye, Reprise, Roulette, Royal, Somerset, Sonet, Sprint, Storyville, Studio SM, Super Majestic Swing, Teddy, Tempo, Tico, Titanus, Tono, Triomphe du Disque-Francais (Vogue), Typic, Uni-Disc, Valois, Vogue

FON-GESELLSCHAFT mbH

Seidenhofstrasse 14, Lucerne
Distributors of: Ecclesia, Harmonia, Mundi, Politeia

International Italia, Jolly, Kabarett aus Wien, Kapp, Lebendiges Wort, Metronome, Minivox, Music, Musica Mundi, Musica Sacra, Patmos, Society for Forgotten Music, Stella, Time, Unikum, Vox, Bella Musica, Jazztone, Mercury, New Jazz, Patmos, Prestige, Supertone, Welt-melodie, Cabaret aus Wien.

LA LIBRAIRIE NOUVELLE

3, Rue Levrier, Geneva
Distributor of: Chant du Monde

Lay John,

Bundesstrasse 13, 6000 Luzern
Blue Bell, Casino, Crown, Fonola, Green Record, Hocky, Karim, Mandolino, Maxim, Melody, Musica et Littera, Orchestrola, Polar, Red Record, Regent, Riviera, Savoy, Sharp, Starlet, Vedette, Work Wide.

Liber & Ligrist,

Oversea Records, 8154 Oberglatt ZH
Clan Celentano, Delta, Embassy, Fidelio, IPM, Italmusica, Jaguar, Maietti, Oversea, Palette, Panorama, Pig, Primary, Ri-Fi, Sir, Togo, Variety, Zephyr

MERCURY RECORD CORPORATION

International Division
5, Quai du Mont-Blanc, Geneva

Musikvertrieb AG,

Badenerstrasse 555, 8000 Zurich.
Tel (051) 54 97 54
Ace of Clubs, Ariola, Argo (Europa), Atlas, Baccarola, Barclay, Baronet, Bel-Air, Camden, Capitol, Carina, Cinevox, Colpix, Club, Crown, Decca, Ducretet-Thomson, Elite Special, Eurodisc, Festival, Galleria del Corso, Hed Arzi, Hispavox, London, Oiseau, Lyre, Polaris, RCA, RCA Camden, RCA-Victrola, RCA-Vik, Ricordi, Seeco, Telefunken, Teletar, Triola, Tropical, Tavola, Rotonda, Twist, Vega, Warner Bros., Felsted, Funckler.

Phonag Schallplatten AG,

Stadthausstrasse 69, 8400 Winterthur.
Tel (052) 6 62 31
CBS, Amadeo, Vanguard, Phonag, Phonocolor, Blue Note, SABA.

Philips AG,

Edenstrasse 20, 8000 Zurich 2
Tel. (051) 25 86 10
Audio-Fidelity, Battle, Bluesville, Caedmon, Critere, Fidelity, Fontana, Jazzland, Mercury, Moodsville, Orpheus, Pacific Jazz, Pergola, Philips, Riverside, Swingville, Vee Jay, World Pacific, Melodicon, Olympia

RCA INTERNATIONAL LTD.

14, Rue de Mont-Blanc, Geneva

Siemens EAG,

Lowenstrasse 35, 8000 Zurich 1,
Tel. (051) 25 36 00
Adano, Archiv Produktion, Brunswick, Cadence, Command, Coral, Deutsche Grammophon Gesellschaft, Duniaphon, Fonit, Heliodor, MGM, Italdisc, Polydor, Tip, United Artists-Verve.

Turicaphon AG,

8611 Riedikon/Uster, ZH
Tel. (051) 87 43 11
Baidaphon, Asmahan, Elite Special, Ricordi, Triola, Phonocolor

Vogue SA,

Avenue des Alpes, 1820 Montreux
Tel. (021) 62 45 55
Adventure, Arlequin, Belter, Chancellor, Circus, Contrepoint, Debut, Durium, Cam-Curci, Carosello, Erato, Fiori Musicali, Gazell, Gene Norman, Crescendo, Jardin des Arts, Jazz Collector, Jazz Selection, Dixieland Jubelle, Mode, Nixa, Orfeon, Dimsa, Piccadilly, Pop, Pye, Golden Guinea, Reprise, Resonances, Roulette, Royal, Somerset, Sonet, Sprint, Storyville, Studio SM, Swing, Tempo, Titanus, Tico, Tono, Typic, Vogue, Disc AZ, Vogue Kangaroo, Vogue Pingouin, Vogue Cochon d'Inde, Majestic, Super-majestic, King Jazz, Dounia, Pastorale et Musique, Unidisc, Everest, Triomphe du Disque Francis, Colpix, Top Rank, Victory, Valois.

SWITZERLAND—MUSIC PUBLISHERS

Alpina Aberbach GmbH
c/o Hans Jecklin
Ramistrasse 42
8000 Zurich 1
Tel: 24 39 41

Edition Melodie
Brunnenwiesenstrasse 26
8049 Zurich 10/49
Tel: 56 70 60

Edition Annabella
Weidstrasse 11
8610 Uster
Tel: 87 30 72

Musikus GmbH
Weidstrasse 11
8610 Uster
Tel: 87 30 72

Editions de Belmont S.A.
Avenue des Alpes 70,
MONTREUX.
Tel: 62 45 55

Sidem
8 rue de Husse
1200 Geneve
Tel: 25 59 55

Willy Bestgen
Postfach 25
7270 Davos 2
Tel: 3 54 38

Southern Music AG
Hauptpostfach 617
8000 Zurich
Tel: 42 31 38 (Brunner)

Edition Coda
Brunnenwiesenstrasse 26
8049 Zurich 10/49
Tel: 56 70 60

Turicaphon AG
8611 Riedikonbei Uster
Tel: 87 43 11

Edifo SA
Badenerstrasse 334,
8000 Zurich 4
Tel: 54 64 77

Walter Wild
Aehrenweg 11
8056 Zurich 56
Tel: 48 45 66

Flora GmbH
Weidstrasse 11
8610 Uster
Tel: 87 30 72

Cadenza Edition
8 rue de Husse
1200 Geneve,
Tel: 25 59 55

Helbling & Co.
8604 Volketswil/Zurich
Tel: 86 43 93

Interton
Zweierstrasse 35
8000 Zurich 4
Tel: 27 83 85

Mondia Music
8 rue de Husse
1200 Geneve
Tel: 25 59 55

SERVING THE INTERNATIONAL MUSIC BUSINESS
FASTEST RECORD DELIVERY THROUGHOUT THE WORLD BY AIR MAIL
COMPLETE LINE OF ALL AMERICAN LABELS

ALL NEW RELEASES **AIRDISC U.S.A.** SINGLES • ALBUMS
Every quantity shipped. Prices on request. Box 545, Radio City Station New York, N. Y. 10019
Payments by bank draft or International Money Order or on account.

FIRST IN MUSIC—
FIRST IN RECORDS!

EDITION CODA
PICK RECORDS
OF
SWITZERLAND

The Active Publishing Company With Its Own Record Affiliation
EDITION CODA • POSTFACH 260 • 8049 ZURICH
PICK RECORDS • POSTFACH 198 • 8049 ZURICH

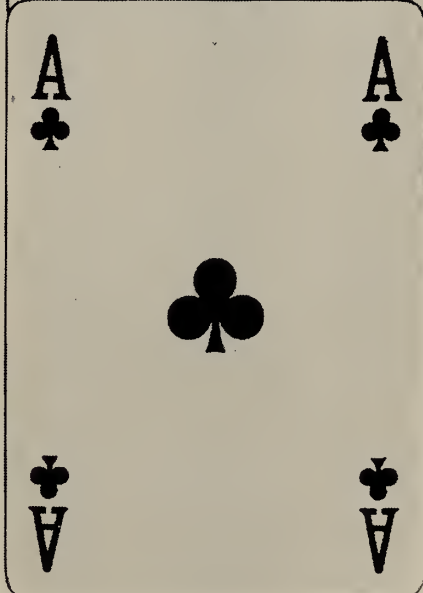

is it possible?

6 different aces



yes it is possible, and this is presented to you by **ARISTON** records with these brilliant interpretations



Ariston
RECORDS

e
GRUPPO EDITORIALE ARISTON

Milano Piazzetta Pattari 1/3
telefono 897745/46/47



giorgia vercellini

ITALY—The Past Twelve Months

Looking back at the past twelve months, it seems that the "crisis" is the major issue on our musical scene.

In our editorial of last year's Anniversary Edition we said that the year could be split into two parts; the first saw the extraordinary success of Bobby Solo's hit, "Una Lacrima Sul Viso," which reached the highest point of our sales; while in the second part sales decreased to levels as low as any in the past.

This year, starting our report from July 1964, the general level of business in our field may become lower at any moment.

As a general opinion, we would say that the sales level has suffered from a crisis since the summer of 1964, though it has constantly maintained its level of sales, without any further decrease.

This opinion, of course, concerns the record field, because as far as the publishing field is involved we can say that pubberies have not suffered from any particular decrease in their business volume; but they did not have any increase in their earnings during the past twelve months, as in the past years.

During 1960 and 1961 the average of yearly record sales was about 24,000,000 of disks.

At the end of 1961 and beginning of 1962, record sales started increasing step by step, and we think that the Italian record industry reached in 1963 the top point of its expansion with a total of about 30,000,000 records sold during that year, an average of 2,500,000 per month.

Perhaps this average was surpassed during the first three months of 1964 thanks to the San Remo festival. But immediately after the million copies were sold of "Una Lacrima Sul Viso" and "Ogni Volta," there was a slow decrease in record sales particularly accentuated during the "low season" (months of Sept., Jan., Apr. and May).

We have reasonably calculated the percentage of decrease in total sales with respect to 1963, and can state, with a good margin of certainty that, in spite of the alarmistic cries the percentage of decrease is about 20%.

This means that the crisis has put the market back to the usual sales levels of 1960 and 1961. We suppose, therefore, that in Italy, during past twelve months, 24 million records have been sold.

We wish to examine the real reasons for this crisis: it is supposed that the crisis stems directly from the general economical slump which has afflicted Italy since 1963. We almost agree with such an opinion, and consider the general situation as the primary cause of the crisis in record business. Of course along with this principal cause there are other concomitant circumstances which do not help the industry to face this difficult moment, in spite of the few symptoms of recovery.

First of all, as we had the occasion to stress out in our Christmas Edition, there is a deep change in the structure of our industry; since, little by little, business is concentrating with few well organized enterprises, leaving the small firms a complementary role in the market.

This is confirmed by the fact that all top hits in the past twelve months have been issued by well known labels: from July 1964 to June 1965, these are the companies that dominated the hit-parade: Ri.Fi (Mina's "E' L'Uomo Per Me"; "Un Anno D'Amore"), EMI Italiana (Richard Anthony's "Cin, Cin"; "La Mia Festa"; "Piangi";/Pino Donaggio—"Io Che Non Vivo"); RCA Italiana (Gianni Morandi—"In Ginocchio Da Te"; "Non Son Degno Di Te"); Dischi Ricordi (Bobby Solo—"Cristina"; "Se Piangi Se Ridi"; "Quello Sbagliato"/the Minstrels—"Le Colline Sono In Fiore"); Durium (Nini Rosso—"Il Silenzio"); SAAR (Petula Clark—"Ciao Ciao"); Cellograph-Simp (John Foster—"Amore Scusami"); Clan Celentano (Adriano—"Il Problema Piu' Importante"). All these firms shall be considered as "big" companies, having a staff of more than 80 employees, with

the only exception of Cellograph Simp and Clan Celentano which can be considered as "medium-sized" firms.

It's also interesting to note that in 1963 there was a small group of disks which sold extraordinarily well, remaining at the top of the charts for a long time; in the past twelve months there were many releases that, without selling a great number of copies, have entered the charts for only one, two or three weeks. Therefore, we can say that during this last period the market has been characterized by an extreme mobility. This may mean that the public is not disinterested in records, but it is looking for something new which is not found in the present situation. It seems that in the last few months all record production presented on the market was characterized by quite a similar "taste." This may be another reason for the present crisis.

Of course the lack of new product is also afflicting the publishing firms, and many A&R men have confirmed that it's particularly difficult at this moment to find repertoire able to satisfy their exigencies.

The third cause of the present crisis is the chronic problem of lack of co-operation by part of the Radio & TV Monopoly. This problem is, of course, emphasized during this last period.

The great number of music festivals organized in Italy was a direct reply to this problem, since thanks to the TV media, these were the only promotional ways easily accessible to the Italian music industry.

Now, after years of similar manifestations, the public has lost interest in these shows, which are overloaded with an endless list of singers and songs, many of them completely unknown. The number of these contests, together with the great numbers of singers and tunes presented each time, has completely bewildered the customers who are unable to make their choice on the record market, as has been demonstrated by the sparse promotional benefit of the recent top festivals. This is a further negative point in the list of the circumstances which have caused this predicament of our musical market.

And now a short report on the top events of past twelve months:

JULY

Decca Italiana started its own domestic production. The first Italian artist introduced by this label was Lalla Castellano, a 16 years old songstress.

Ri-Fi Records, along with its Lebanese associates Mario & Michel Haddad formed a company in Beirut called Societe' Libanaise Du Disque. They built the first pressing plant in Lebanon, one of the few existing in the Middle East.

The contest "A Disk for the Summer" was organized by RAI & TV in cooperation with the Italian Phonographic Association (AFI), at the final night of Saint Vincent, declared winners I Marcellos Ferial, with the song "Sei Diventata Nera" which was one of the top sellers of the summer totalling about 600,000 copies. Record was released on the Durium label. "A Disk for the Summer" was the first example of cooperation between our Radio-TV Monopoly and the record industry.

This month, for the first time, the crisis which has affected the Italian record market was suddenly noticed. To get worse, the situation featured a great number of new releases, which Italian record firms presented on the market for the summer season, introducing them through festivals and contests. "A Disk for the Summer" has presented 42 new decks. International TV Contest of Pesaro presented another 28 releases, International TV Show of Venice was responsible for the introduction of 35 new recordings, while Cantagiuro served as a launching point of 31 disks, followed by the televised RCA Show at Hotel Hilton in Rome, where 15 new disks were presented. This totals 151 new sides. We estimated that all disks released on our market for the summer season reached about 300 singles. This over-

production was one of the principal reasons for the summer crisis.

Among the top events of July were the International TV Show of Venice organized by Gianni Ravera (the organizer of the San Remo Festival) at which 35 artists took part, (24 Italians and 11 top foreign talents). Among them Richard Anthony (EMI Italiana) who introduced his extraordinary hit "Cin Cin", Petula Clark, and Françoise Hardy, both of Saar.

Gianni Morandi was declared the winner of "Cantagiuro," the greatest summer happening, organized by Ezio Radaelli. After a long tour all around Italy, presenting his song "In Ginocchio Da Te," which was the top hit of the year, young RCA artist Morandi was declared the winner at the final televised night of Fiuggi (Rome). Second place went to another RCA artist, Michele, who presented "Ti Ringrazio Perche," followed in third position by the Durium talent of Little Tony, who performed "Non Aspetto Nessuno." Both these songs were included among the top 30 hits of the year, confirming the promotional power of Radaelli's "Cantagiuro." These artists were winners of the "A" team. "B" team's Paolo Mosca, a new discovery of a little label called "Lord Record," won in this division.

Giuseppe Gramitto Ricci, head of Curci publishing firm, announced the finalization of the deal for the exclusive representation in Italy of the Dick James' catalog (London). Curci will also be the publisher in Italy of all The Beatles' hits.

AUGUST

Saar announced the finalization of the deal for the exclusive representation and distribution in Italy of Dot Records' catalog. Saar also announced that it will introduce on September first Italian recordings of Pat Boone.

During this month buyers made their definite choice among the records put on the market for the summer season: first on the chart is the extraordinary talent of Gianni Morandi (RCA) who will reveal himself as one of the best selling artists of the year. The title at the top of the hit parade is the one he presented at "Cantagiuro": "In Ginocchio Da Te." At the end of the year, the disk had sold more than 800,000 copies. The new summer disk of Adriano Celentano, under his own label Clan, was at the top of record sales. Title of the top selling disk is "Il Problema Piu' Importante" (Italian version of "If You Gonna Make A Fool of Somebody").

Another success of summer 1964 was "Amore Scusami," a song which served to reveal the talent of John Foster, issued under the Phonocolor label. This title was presented at the contest "A Disk For The Summer," and also reached first position in record sales. Then there was the top selling record of I Marcellos Ferial, issued under the Durium label and also presented at "A Record For The Summer": "Sei Diventata Nera." Other hit of the month was "Con Te Sulla Spiaggia," introduced also through the TV contest by RCA top talent Nico Fidenco.

The list of the summer hits continued with Michele's "Ti Ringrazio Perche" under the RCA label. Michele introduced this title via "Cantagiuro." Then, for the first time the name of the new RCA discovery, Dino entered the list of the best selling artists. His song was "Eravamo Amici," also presented at "Cantagiuro."

Richard Anthony's "Cin-Cin" was still listed among the top ten best sellers for the 17th consecutive week.

Same thing for Mina. The top Ri-Fi talent continues with her success with "E' L'Uomo Per Me" (He Walks Like A Man), which is still selling for the 14th consecutive week.

During the month, Ray Charles visited Italy, performing at La Busso-la, the top Italian Summer Music Hall in Viareggio. Richard Anthony, another EMI talent, tours Italy.

SEPTEMBER

In Rome at RCA Italiana a meeting is held of all RCA associates of Spanish speaking countries. This is perhaps a direct consequence of the success that Italian songs and Italian RCA artists enjoy in Spain and Latin American countries.

In Barcelona, the recent young discovery of Dischi Ricordi, Wilma Goich, is proclaimed winner of the Mediterranean Festival, held in that town with the participation of Spain, Italy, and France. The song she performed was "Ho Capito Che Ti Amo," penned by Luigi Tenco. The Wilma Goich's recording will reach a top selling position on the Spanish charts.

Ri-Fi released the first LP of Mina issued under its label. The album, which includes 12 evergreens of different countries of the world, obtains an immediate, good reaction. It was to receive a special critics' award.

The first Italian million record seller, Bobby Solo, tours around the world, introducing his San Remo hit, "Una Lacrima Sul Viso" (Ricordi). After a series of personal appearances in Germany, he leaves for France, then for Japan, and South America, where his San Remo top seller was listed at the top of the charts.

MRC—Milano Record Company, the new record company formed by Alberto Carisch, prexy of Italian Southern, announced the finalization of the deal for the distribution of its catalog in Germany by part of Teldec (Hamburg).

Cellograph-Simp (Phonocolor) signed a contract with Deutsche Vogue for the distribution and promotion in Germany of all of John Foster's recordings.

The Ri-Fi catalog will be distributed in France by Disques Festival under the International label, connected with Italia Schallplatten of Dr. Karl Heinz Busse.

CGD Internazionale introduced in Italy the extraordinary vocal group Les Surfs (originally pacted by Disques Festival of Paris) with the first Italian recording of "Maintenant Tu Peux T'En Aller" under the title "E Adesso Te Ne Puoi Andare." Disk was to reach the first position in the charts.

OCTOBER

The Festival of Neapolitan Songs, organized in Naples by Ravera, was won by Domenico Modugno thanks to his song "Tu Si Na Cosa Grande" (published by Curci). Modugno's song won also, thanks to the marvelous performance of Ornella Vanoni (Ricordi).

It seems that in spite of the crisis which afflicts the singles record market, sales of LP albums are still maintaining usual levels as in the past. This perhaps owes thanks to the particular initiative introduced by all top record firms particularly in the classical field. We wish to mention the special low priced series of RCA Italiana, who was first to present the Italian market with classical LP's at a price of Lit. 1,800 (about \$3.00) when the usual price was Lit. 3,300 (about \$5.30). The example of RCA was followed by EMI Italiana with the "Invitation to Music." This month also saw Dischi Ricordi introduce a low priced series of high quality classical recordings under the title "Classics of Classical Music." Price of each album is of Lit. 1,800. (about \$3.00).

The first Japanese recording by Mina, "Un Buco Nella Sabbia," released by King Records of Tokyo, entered the charts, reaching the top of the Japanese hit parade with a total sale of more than 250,000 in that country.

EMI Italiana declares that they are satisfied with the level of the sales for the summer season. This, in spite of the crisis which strongly touched the Italian market. EMI's satisfaction derives from the great success obtained by the French talent Richard Anthony, who was at the top of the chart first with "Cin-Cin" and now with "La Mia Festa," which entered the top ten best sellers list immediately.

(Continued on page 98)

DURIUM is proud to introduce the
BIGGEST CONTINENTAL HIT
IL SILENZIO
WITH NINI ROSSO



1ST ON THE CHARTS IN

ITALY
GERMANY
AUSTRIA
SWITZERLAND
HOLLAND

DURIUM
HANSA SCHALLPLATTEN
CENTROCORD
VOGUE
M. STIBBE & CO. N.V.

■ ■ WILL BE RELEASED SHORTLY IN:
■ ■ **USA** by COLUMBIA RECORDS
■ ■ **GREAT BRITAIN** by PYE RECORDS
■ ■ **FRANCE** by VOGUE
■ ■ **JAPAN** by COSDEL

DURIUM RECORDS · PASSAGGIO OSII, 2 · MILAN · ITALY



COMING THIS SEASON
THE FILM YOU WAITED FOR

Federico Fellini

**GIULIETTA
DEGLI SPIRITI**

MUSIC BY
NINO ROTA



VIA VIRGILO 8—ROMA



ITALY



ITALY—The Past Twelve Months

(Continued from page 96)

diately after the release. "Festa," the Italian version of the American hit "It's My Party," remained at the top of our charts over 11 weeks. EMI also enjoyed good sales thanks to the Belgium's Italian talent, Adamo, whose recordings showed good sales between 50,000 and 100,000.

The Festival Delle Rose, organized in Rome (Hotel Hilton) by Mario Minasi, had as a winner Gianni Morandi, who, via this televised show, introduced his new big hit "Non Son Degno Di Te" (RCA). The disk continued Morandi's hit string and remained at the top of the charts for many weeks.

Ri.Fi introduced the special Command series of LP's derived from 35mm film tapes groovings.

Adriano Celentano cut a new disk, "Bambini Miei". Sales earnings from this disk will be devoted to the United Nations Organization for Poor Children. It soon entered the charts, and was listed among the 30 top selling disks of the year.

NOVEMBER

All responsables of the Italian music industry were very busy preparing for their participation in the next San Remo Festival. All odds are strongly on this exposition's furnishing a definitive solution to the record crisis. Ravera's Festival listed foreign participators, among them: Petula Clark, the Minstrels and Gene Pitney, who enjoyed a particular success at the San Remo scene. Also announced were the French group Les Surfs.

AFI (Italian Phonographic Association) informed us about definitive results of the contest "A Disk for the Summer" according to record sales, during a special televised Gala held at Saint Vincent. Winners were "Sei Diventata Nera," sung by Los Marcellos Ferial, followed by Nico Fidenco's "Con Te Sulla Spiaggia"; while

third position went to John Foster's recording "Amore Scusami."

Fonit-Cetra announced the finalization of the deal for the exclusive representation and distribution in Italy of the American catalog of Kapp Records.

Gianni Morandi, the young talent of RCA Italiana, is best selling artist of the Summer season, resulting from a definitive balance of the summer sales on the record market, thanks to his big hit "In Ginocchio Da Te," which was on the Italian charts for 22 weeks.

According to this balance we estimate that the decrease in summer sales of 1964 is of about a 25% from the season's sales of 1963.

DECEMBER

Ricordi announced that more than two million disks of the Bobby Solo's recording "Una Lacrima Sul Viso" have been sold on the foreign market. In Italy, sales of this disc have passed 1,300,000 mark.

Top event of the month stemmed from the sudden decision by RCA Italiana to withdraw its participation in the San Remo Festival. The news exploded on the music scene like a bomb. The decision was based on the fact that, according to RCA Italiana, the San Remo organizers didn't take into sufficient consideration the weight and the role which it is playing on the musical scene in our market.

Another surprise was caused by the fact that the final song selection also excluded works of well known composers such as Giulio Libano, Dominic Modugno, Ennio Morricone, Giovanni Danzi, Mario Panzeri by the exclusion of interpreters such as Nico Fidenco, Modugno himself, Adamo and Tony Renis.

Durium announced the release of the Nini Rosso recording, "Il Silenzio," which, in a few months, reached the top of the charts in Italy and

in many other countries abroad.

Italiana Decca announced that for the first time the company will take part in the San Remo contest. The firm was represented by its English artist Anita Harris.

EMI Italiana signed an exclusive pact with film actress Marisa Solinas, who debuted as songstress under the EMI label.

JANUARY

RCA Italiana brought TV to its Rome Studios for a big talent & new production showcase. The show was organized by the firm to promote its winter production and TV responsables agreed to record the event on a video tape which was presented on the TV screens immediately after San Remo Festival.

Since this show included all the songs and singers that should have been presented by RCA on the San Remo stage, the publicity put out by RCA on this fact created a controversy which obliged the TV responsables to postpone the transmission of the program.

We wish to say anyway that from such a TV production, which was presented on the screens in the month of May, came successes like "La Verita'" by Paul Anka, "Te Lo Leggo Negli Occhi" by Dino and "Vivro" by Alain Barriere.

The Festival of San Remo is once again confirmed as the top manifestation on the musical scene in Italy.

This is demonstrated by the great interest shown by the public and the press not only in Italy, but all over the world, and it's stressed by the great number of foreign visitors coming to San Remo from far and wide for the three nights of the event.

After the three night contest, "Se Piangi Se Ridi," sung by Bobby Solo (Ricordi) and by the New Christy Minstrels, (CBS) was declared the winning composition of the contest. But, in spite of the extraordinary

publicity given to the contest, in which such talents as Connie Francis (CGD Internazionale), Gene Pitney (CGD Internazionale), Johnny Tillotson (CGD Internazionale), Timi Yuro (Phonogram), Petula Clark (Saar), Dusty Springfield (Phonogram) Les Surfs (CGD Internazionale) and others have appeared as foreign representatives, along with top Italian artists such as Bobby Solo (Ricordi), Ornella Vanoni (Ricordi), John Foster (Phonocolor), Fred Bongusto (Fonit-Cetra) Betty Curtis (CGD), Pino Donaggio (EMI Italiana), Remo Germani (SAAR) Peppino Gagliardi (SAAR) and Ricky Gianco (Jaguar), record sales results have to be considered completely negative. We estimate that, all together, San Remo discs have not surpassed a total sale of 2,000,000 copies, which in the present crisis situation is also the average of monthly sales on the Italian market.

Of course, as in the past San Remo festivals, new discs have quickly entered the charts, since all record sales have been immediately concentrated on these new releases, but only a few of the San Remo songs can be considered as medium hits. The same number one, "Se Piangi Se Ridi," was on the top of the charts for 6 weeks only, while last year a Bobby Solo disc, "Una Lacrima Sul Viso," was at the top of our hit parade for about 16 weeks, and remained in the top ten in the charts for more than 25 weeks. Among the other hits derived from the San Remo contest we have to mention "Io Che Non Vivo" by Pino Donaggio (EMI Italiana), which, without reaching the top of the best sellers list, was also listed among the top ten for more than 16 weeks, and enjoyed good sales. After this there are "Le Colline Sono In Fiore" by The Minstrels, (CBS), "Invece No" by Petula Clark (SAAR), "Amici Miei"

(Continued on page 102)

RIFI
RECORD COMPANY

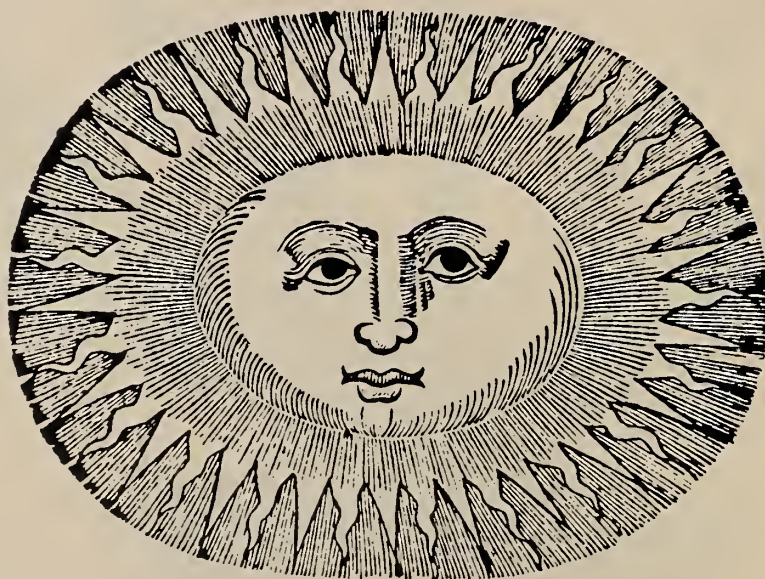

**SUMMER SEASON
- LIKE ALL THE SEASONS -
IS RIFI'S SEASON
IN ITALY
AND IN THE WHOLE WORLD**

**TONY DALLARA ■ FABRIZIO FERRETTI ■ GIORGIO GABER ■ I GIGANTI ■
AUGUSTO MARTELLI ■ COCKI MAZZETTI ■ MINA ■ MEMO REMIGI ■
IVA ZANICCHI ■**

ITALY: CORSO BUENOS AIRES 77 - MILANO - TEL. 2042117 - 2042119

U.S.A.: C/O ROEMER - 400 MADISON AVENUE - NEW YORK 17 N. Y.



BOBBY SOLO: 1,400,000 RECORDS

SOLD OF "UNA LACRIMA SUL VISO"



ORNELLA VANONI WINS THE 1964

NAPLES FESTIVAL



BOBBY SOLO WINS THE 1965

SAN REMO FESTIVAL



????????????????????????????????



DISCHI RICORDI s.p.a. IS THE COMPANY THAT HAS CONTINUOUSLY HIT THE BULL'S EYE DURING THE LAST TWO YEARS...AND WE HOPE YOU WON'T OBJECT IF WE CARRY ON.

A GREAT CAST OF ITALIAN ARTISTS...THE DISTRIBUTION OF A WIDE RANGE OF FOREIGN LABELS...A VAST EXPERIENCE BEHIND US... ORGANIZATION...WHAT ELSE DO YOU NEED?

ITALY - The Past 12 Months

(Continued from page 100)

by Gene Pitney (CGD Internazionale) and "Cominciamo Ad Amarci" by John Foster, one of the best songs presented this year on the San Remo stage, have obtained a sufficient level of sales without entering the finals.

FEBRUARY

The Mina disc, "La Citta Vuota" (Italian version of "Lonely Town"), reached the top of the chart in Spain. The recording, issued under the Ri-Fi Original label, is distributed in Spain by Belter. For this success the lark was awarded with a golden disc.

Bobby Solo cut the foreign version of his San Remo hit, (the winning composition) "Se Piangi Se Ridi." Immediate releases of the disc is planned by Dischi Ricordi representatives in all countries of the world.

Campi Brothers (Giuseppe and Luigi) visited Spain where they formed a publishing firm which will issue in Spain their original film music production. Campi Publishing firm is well represented at the top of the charts in that country thanks to their hit "More" taken from the film "Mondo Cane."

Another Italian hit on the foreign market was "Il Mio Mondo" originally published by Ariston Publishing Group, and recorded in France by Richard Anthony (French EMI) under the title "Ce Monde." The title reached the top ten charts.

Durium announced the finalization of the deal with Tamla-Motown, for the exclusive representation of this line in Italy. First artists to be promoted were The Supremes.

MARCH

The crisis on the record market was the deepest during this month, since sales registered a further decrease in spite of few symptoms of a general recovery from the economic slump. Sales results of the San Remo recordings completely disappointed the industry.

In the meantime Emi Italiana enjoyed another great success thanks once again to Richard Anthony whose new disc "Piangi" (Boys Cry) immediately entered the charts jumping up after a few weeks to the top position on the best sellers list.

The fortunate Emi Italiana series of hits continued thanks to Adamo who did very well with "Cade La Neve."

CGD Internazionale signed a pact with the well known twin sisters Hellen and Alice Kessler.

Tony Dallara, finished his pact with SAAR, the label who first introduced him, and has signed a new agreement with Ri-Fi.

Ariston Publishing Group, after having extended its activity to the record field, with the opening in 1964 of a label (Ariston), is continuing its program of international expansion. Alfredo Rossi, prexy of the firm, announced the finalization of the deal in Spain for the opening of the pubery Ariston-Spain, which became part of the Armonico Publishing Group of Barcelona. Alfredo also announced the formation of a new subsidiary company in France called Ariston France, which will be run by Gilbert & Marcel Maruani.

In the record field new exclusive pacts were signed by Ariston with two pop combos, Bruno Martino and Marino Barreto Jr.

Fonit-Cetra renewed its cast of artists to enter with new power into the singles market. This is the reason why they signed an exclusive agreement with two of the top Italian singers: Sergio Endrigo (formerly under contract with RCA Italiana) and Fred Bongusto (formerly with Ri-Fi).

APRIL

Top April event in Italy was the Eurovision contest which was held in Naples. Winner was the little French girl France Gall (Phonogram) with the song "Pupée de Cire Pupée de Son" which was released in Italian and promoted on the Italian market by Phonogram.

Italian representative was of course Bobby Solo (Ricordi) who presented the San Remo winner "Se Piangi Se Ridi".

Mina was awarded a plaque in Japan thanks to her big hit "Un Buco Nella Sabbia" which she sang in Japanese. Being in Japan she got a "Pearl Disc".

CGD held in Milan a big convention. Convention was concluded with a night show which was televised. Among foreign artists which took part in the show were Katyna Ranieri, Teddy Randazzo, The Everly Brothers and Samatha Jones. Among the Italian stars were: Betty Curtis and Johnny Dorelli, and Tony Dallara.

The wellknown journalist Maso Biggero was appointed A&R Manager of Phonogram.

Peppino di Capri was at the top of the Germany charts thanks to his hit "Melancolie" distributed in that country by Italia Schallplatten. Peppino Di Capri's home label is Carisch.

MRC announced that its catalog will be distributed in France by Philips, and in Belgium by Artone.

Dischi Ricordi announces the conclusion of the agreement for the exclusive distribution in Italy of the two lines of Hickory and Epic. First Epic artist to be promoted in Italy was Bobby Vinton, who will make his first appearance in our country in the International Light Music Show in Venice in June.

The classical low priced series of EMI Italiana, "Invitation to Music" reached an unexpected sales success: for this reason, EMI Italiana has announced the release of the series in stereo, which were sold at a price of Liras 2.400 (about \$4.00). Dealers particularly welcomed the initiative.

Similar program was followed by Decca Italiana, which also released a classical stereo series under the label, Asso Di Quadri.

MAY

In the classical field, Decca Italiana announced the release of an album performed by the world famous pianist Arturo Benedetti Michelangeli. Album was titled "The Pianistic Art of Arturo Benedetti Michelangeli."

The TV show produced by RCA Italiana and recorded in January was put on the air: good reaction was immediately obtained for the songs "La Verita" by Paul Anka, "I Giorni Dell'Amore" by Michele and "Lui" by Rita Pavone. These titles entered on the charts.

Ariston Records announced the finalization of the deal with Disques Barclay of Paris for the exclusive distribution of their line in France, Benelux and Switzerland (excluding Canton Ticino).

Jaguar Records presented on the music scene the extraordinary talent of the Italian tenor Gino Bechi. Jaguar has released an LP containing 12 of the most famous Italian songs produced from 1920 until 1924, interpreted by Bechi.

JUNE

The 1965 edition of "Cantagiuro," the big contest organized by Radaelli, starts its fantastic tour of 17.000 kms on June 23. This was considered the top event of the summer. The group of 42 singers toured all of Italy for 16 days, performing each night in a different place, and then flew to Moscow, Frankfurt, and Vienna, and introduced for the first time a big Italian light music show in foreign countries. The winner of team "A" of this Cantagiuro was Rita Pavone, the girl "star" of RCA Italiana, who for the first time accepted to take part in a contest. She was declared winner the final night of Fiuggi, thanks to her song "Lui," which is still listed on our top ten charts. At second place was Gianni Morandi, who presented "Se Non Avessi Piu' Te," which also is selling extremely well. I Marcellos Ferial, presenting the Italian version of "The House of The Rising Sun" under the title "La Casa Del Sole" were classified in the third position. Their disk is issued under the Durium label.

(Continued on page 104)

ITALY RECORD MANUFACTURERS

ANGELICUM
Tel. 654.610
Piazza S. Angelo 2, Milan
Distributed by Decca

ARCOBALENO JOCKEY
Tel. 266.982
Via Indipendenza 32, Napoli
Director: Mr. Bianchi
Labels: Arcobaleno Jockey

ARISTON RECORDS-IFI Company S.p.a.
Tel. 897745
Piazzetta Pattari 1/3, Milan
Director: Mr. Alfredo Rossi
Labels: Ariston
Recording moulding factory: San Giuliano Milanese.

C.A.M.
Tel. 314341
Via Virgilio 8, Rome
President: Mr. Giuseppe Campi
General Manager: Mr. Luigi Campi
Label: CAM.

CARISCH
Tel. 650741
Via Feneral Fara 39, Milan
Director: Mr. Galli
A/R Manager: Mr. Mazzocchi
Labels: Carisch, Odeon, Parlophon, Parlophon-King
Recording studio: Via Monviso 17, Milan

CELLOGRAF-SIMP
Tel. 371130
Via Maffucci 18, Milan
Directors: Mr. Rota, Mr. Sciascia
Labels: Phonocolor, Primavera, Style, Big Ben
Record moulding factory: Via Maffucci 18, Milan

CEMED-CAROSELLO
Tel. 791440
Via Beccaria 5, Milan
Director: Mr. Gramitto Ricci
Labels: Buenavista, Carosello, Curci, Curci Erato, Disneyland, Costanza, Triola, Topolino, Italian Yank.
Distributed by: C. & C.

CINEVOX
Tel. 461614
Via Veneto 108, Rome
General Manager: Mr. Bixio

CLAN CELENTANO
Tel. 781612
Corso Europa 5, Milan
Director: Mr. Alessandro Celentano
Labels: Ciao Ragazzi, Clan, Fantasy
Distributed by: C. & C.

COMPAGNIA GENERALE DEL DISCO C.G.D.-C.G.D. INTERNATIONALE
Tel. 794841
Galleria del Corso 4, Milan
President: Mr. Ladislao Sugar
C.G.D.:
General Manager: Mr. Franco Crepax
Labels: Acquario, CGD, GC, Sugarmusic, C.G.D. Internazionale
General Manager: Mr. Giuseppe Giannini
Labels: Ascot, Bel Air, Cameo, Carlton, 20th Century Fox, Derby, Everest, Festival, M.G.M. Palette, Parker, Reprise, Riviera, United Artists, Verve.
Record moulding factory: Via Moretto 9, Milan

COMBO RECORD SOCIETA' TREVISAN
Tel. 799158
Corso Europa 16, Milan
Director: Mr. Trevisan
Labels: Combo, Jupiter

DECCA
Tel. 874048
Via Brisa 3, Milan
President: Mr. Bacchini
Director: Mr. Paolo Tosi
Labels: Ace of Clubs, Argo, Decca, London, Oiseau Lyre, Telefunken, (Kapp, Hi, Jamie, Guyden, Big Top, Challenge, Warwick, Sun, Monument, Felsted).

DISCHI RICORDI S.p.a.
Tel. 898242
Via Berchet 2, Milan
President: Mr. Valcarengi
Vice President: Mr. Eugenio Clausetti
Managing Director: Mr. Guido Rignano
Domestic Repertoire: Mr. Iler Pataccini
International Repertoire: Mr. Paolo Ruggieri
Labels: CBS, Club, Ricordi, Round Table, Epic Hickory.
Recording studio: Via dei Cinquecento 1, Milan.

DUCALE EDIZIONI DISCOGRAFICHE
Tel. 702402
Via Beccaria 5, Milan
Director: Mr. David Matalon
Label: Italdisc
Distributed by: DIDEA s.r.l.

DURIUM S.p.a.
Tel. 873494-800618-871303
Passaggio degli Osi 2, Milan
President: Mr. Krikor Mintangian
Export Dept: Mrs. Elisabeth Mintangian
Labels: DME, Durium, Gordy, Jazz Workshop Jugoton, Laurie Records, Motown, Paris, Sprint, Tamla.
Recording moulding factory: Erba, Como.

E.D.I. EDIZIONI DISCOGRAFICHE ITALIANE
Tel. 650675
Via Tarchetti 2, Milan
Director: Mr. Casetta
Labels: Bluebell, Cadence, Canadian, American, Candid, Chancellor, Colpix, Debut, Sonet, Storyville.

E.D.I.B.I. EDIZIONI DISCOGRAFICHE
Tel. 210325
Via S. Pietro a Majella 17, Naples
Director: Mr. Luciano Villeveille Bideri
Label: EDIBI

FONIT-CETRA
Tel. 5777
Via Bertola 34, Turin
Director: Mr. Carrara
Fonit's Labels: Command, Cricket, Fonit, Hi-Fi.
Cetra's Labels: Cetra, Excelsius, Miller, International, Stereo, Fidelity.
Record moulding factory: Via Meda 45, Milan
Recording studio: Via Bertola 34, Turin
Largo Argentina 3, Rome

KARIM
Tel: 592502
Via Maragliano 8/1, Genova
Labels: Baerenreiter, Blue Note, Cantate Schallplatten, Hockey, Karim, Musicaphon, Prestige, Ronnex Records, Valois.
Distributed by Pulvirenti S.p.A.

ITALMUSICA IPM.
Corso Genova 22, Milan
President: Mr. Pignini
Labels: Sir, IPM, Fig. Silver Recor

KING UNIVERSAL Edizioni Discografiche
Tel: 515684
Corso Arnaldo Lucci 137, Napoli
Director: Mrs. Marisa Fierro
Label: King Universal.
Distributed by Phonogram.

JAGUAR RECORDS
Tel. 782337
Galleria Passerella I, Milan
Director: Mr. Benito Vassura
Label: Jaguar
Distributed by: Decca.

JUKE BOX ITALIANA
Tel: 795353
Galleria del Corso 2, Milan
President: Mr. Ladislao Sugar
Director: Mr. Carlo Alberto Rossi
Labels: Checker, Chess, Argo, Juke Box.
Recording Studio: Via Barletta 11, Milan.

MEAZZI
Tel: 867361
Via Piatti 4, Milan
Directors: Meazzi Bros.
Labels: Arpeggio, Astraphon, Baby Records, GBC, Humorplay, Hollywood, Meazzi, Meazzi Classica, Panoramica, Salvador.
Distributed by: C. & C.

MRC-MILANO RECORD COMPANY S.p.a.
Tel: 857714
Via S. Francesco d'Assisi 10, Milan
President: Mr. Alberto Carisch
General Manager: Mr. Piero Gallotti
Labels: MRC, Giovane.
Distributed by Decca.

PHONOGRAM
Tel. 2896217
Via Benadir 14, Milan
Managing Director: Mr. Manlio Baron
General Manager: Mr. Riechhof
A/R Manager: Mr. Maso Biggero
Labels: Archiv Produktion, Brunswick, Coral, Deutsche Grammophon, Fontana, Heliodor, Jazzland, Mercury, Philips, Polydor, Riverside.
Record moulding factory: Via Benadir 14, Milan
Recording studio: Piazza Cavour 2, Milan.

RCA ITALIANA S.p.a.
Tel. 416041
Via Tiburtina Km. 12, Rome
President: Mr. Galeazzi
Managing Director and General Manager: Mr. Giuseppe Ornato
Assistant Manager: Mr. Ennio Mellis
A/R Manager: Mr. Ettore Zeppego
International Liaisons: Mr. Francesco Fanti Salvoni
Labels: RCA Victor, RCA Camden, RCA Serie Europa, Vik, Ducretet Thomson, Discophiles Francais, Barclay, Py-e.
Record moulding factory: Via Tiburtina Km. 12, Rome
Recording studio: Via Tiburtina Km. 12, Rome.

RI-FI RECORD
Tel: 2042117
Corso Buenos Aires 77, Milan
President: Mr. Giampiero Rossi
General Manager: Mr. Giovanni Battista An-soldi
International Dept.: Mr. Giuseppe Velona
Labels: Antoniano, Command Records, Primary, Publiscop, Ri-Fi, Time Record, Variety, Westminster Records.
Record moulding factories: 1) Via Durazzo 2, Milan, 2) Via Quintino Sella 91a, Busto Arsizio.
Printing House: Via Quintino Sella 91a, Busto Arsizio.

S.A.A.R.
Tel: 4696251
Viale di Porta Vercellina 14, Milan
President: Mr. Ernest Gurtler
Managing Director: Mr. Walter Gurtler
A/R Manager: Mr. Ezio Leoni
Foreign Dept.: Mr. Pino di Gioia
Labels: Ateo, Atlantic, Dot, Jolly, Red Bird, Stella, Vogue, Warner Bros., AZ.
Record moulding factory: Via Salvatore Piane 21, Milan.
Recording Studio: Via Gramsci 20, Pero (M'lan).

SURF EDIZIONI DISCOGRAFICHE
Tel. 702408
Galleria del corso 4, Milan
Director: Mr. Piero Rolla
Label: Surf.

VEDETTE RECORDS
Tel: 898248
Via San Paolo 15, Milan
Director: Mr. Armando Sciascia
Labels: Vedette.

VIS RADIO
Corso Umberto I, 132, Napoli
Managing Director: Mr. Scopa
A/R Manager: Mr. Conte
Label: Vis Radio
Recording studio: Cupa Cajafa 36, Napoli

VOCE DEL PADRONE-COLUMBIA-MARCONIPHON
Tel. 434041
Via Domenichino I4, Milan
Director: Mr. Francois Minchin
A/R Manager: Mr. John Lee
Labels: Angel, ABC Paramount, La Voce del Padrone, Capitol, Columbia, Pathe, Impulse, Liberty, King, Coed, Imperial (Germany) Regal, Stateside.
Record moulding factories: 1) Via Domenichino 14, Milan. 2) Viale Umbria 37, Milan.
Recording studio: Via Santa Eufemia 25, Milan.

CLAN CELENTANO

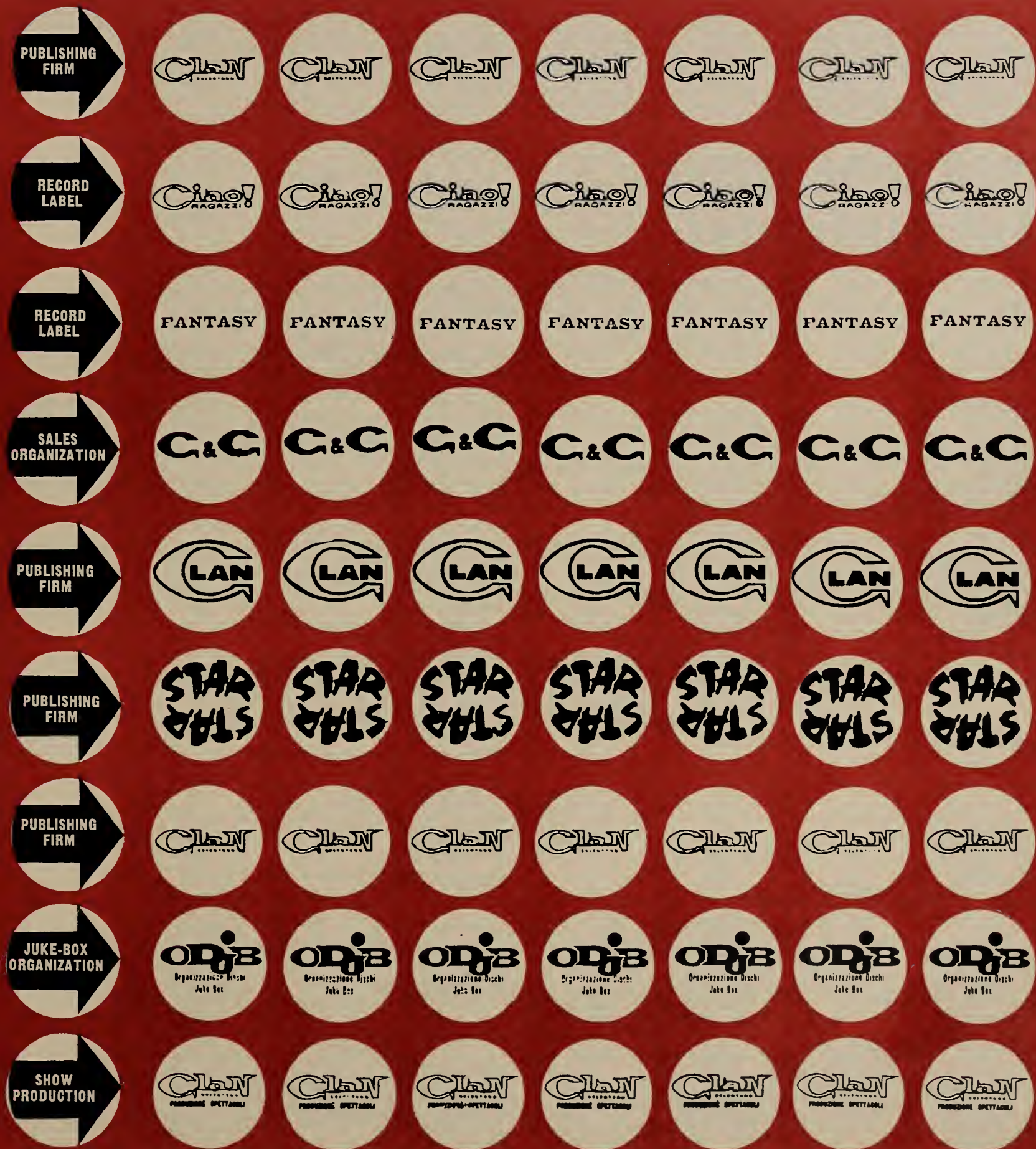

ITALY - MILAN - CORSO EUROPA 5

Phone: 781612

ITALY'S BEST SELLERS OF THE PAST 12 MONTHS

	Label	Publisher
1. In ginocchio da te	Gianni Morandi	RCA Italiana
2. La mia festa	Richard Anthony	RCA Italiana
3. Non son degno di te	Gianni Morandi	RCA Italiana
4. Se piangi se ridi	Bobby Solo	Ricordi
5. Piangi	Richard Anthony	EMI Italiana
6. Le colline sono in fiore	The Minstrels	CBS
7. Io che non vivo	Pino Donaggio	EMI Italiana
8. Un anno d'amore	Mina	RiFi
9. Il problema più importante	Adriano Celentano	Clan
10. Il silenzio	Nini Rosso	Durium
11. Amore scusami	John Foster	Phonocolor
12. E adesso te ne puoi andare	Les Surfs	CGD International
13. Cin cin	Richard Anthony	EMI Italiana
14. Quello sbagliato	Bobby Solo	Ricordi
15. Ciao ciao	Petula Clark	Saar
16. E' l'uomo per me	Mina	RiFi
17. Non aspetto nessuno	Little Tony	Durium
18. Ti ringrazio perché	Michele	RCA
19. Con te sulla spiaggia	Nico Fidenco	RCA
20. Viva la pappa	Rita Pavone	RCA
21. Bambini miei	Adriano Celentano	Clan
22. Invece no	Petula Clark	Saar
23. Amici miei	Gene Pitney	CGD International
24. La verità	Nicola di Bari	Saar
25. Goldfinger	Paul Anka	RCA
26. Eravamo amici	Shirley Bassey	EMI Italiana
27. Lui	Dino	RCA
28. Il mondo	Rita Pavone	RCA
29. Per un pugno di dollari	Jimmy Fontana	RCA
30. La casa del sole	Ennio Morricone	RCA
	Los Marcellos Ferial	Durium

WORLD WIDE MUSIC TRADE DIRECTORY

(Continued from page 90)

PHILIPS (NIGERIA) LTD.—P. M. Bag 1136—APAPA
(21 Warehouse Road—Apapa)
Phone: Lagos 56051
Cable: PHILINIG LAGOS
Pres.: Mr. J. Ch. M. Rijnveld
Labels (domestic) Nigerphone, Philips
Labels (others): CBS, Fontana

PAKISTAN

RECORD MFRS
THE GRAMOPHONE CO. OF PAKISTAN LTD.—P.O. Box 451—KARACHI-13
(C/28, Estate Avenue—Mauripur—Karachi-13)
Phone: 79566, 79149
Cable: JABBERMENT KARACHI
Commercial Director: Mr. Mujib-Ur-Rahman
Labels: Angel, Capitol, Columbia, Decca, His Master's Voice, Liberty, London, Mercury, M.G.M., Parlophone.

PANAMA

RECORD MFRS
GRECHA, S.A.—Apartado 7344—PANAMA
(Avenida 7 Central No 18-81—Panamá)
Phone: 2-1868, 2-5388
Cable: GRECHA PANAMA
Pres.: Mr. Julio Ernesto Sosa
Labels (domestic): Grecha
Labels (others): Angel, Ansonia, Canadian-American, Columbia, Dot, Fuentes, Kubaney, Maype, Miami, Montilla, Orfeon, Panart, Parkway, Seeco, Tropical, United Artists, Westminster, and many others.

PANAMA RADIO CORP.—Aparado 406—PANAMA
(Plaza 5 de Mayo—Panamá)
Phone: 2-0880
Cable: PARADCO PANAMA
Pres.: Mr. Donald Halman
Labels (others): RCA Camden, RCA Victor, among others.

TROPELCO S.A.—Apartado 827—PANAMA
(Via España y Avenida Central—Panamá)
Phone: 3-1285, 3-6157, 2-2051
Cable: TROPELCO PANAMA
Pres.: Mr. Roy M. Bettis
Labels (domestic): Artelec, Tropelco
Labels (others): ABC-Paramount, Alegre, Capitol, CBS, Gamma, Gema, Grand Award, Kapp, Liberty, London, Mercury, M.G.M., Musart, Peerless, Smash, Sono-Radio, Venevox, Warner Bros.

PARAGUAY

RECORD MFRS
ALBATROS S.A.C.I.—Casilla Correo 551—ASUNCION
(Luis Alberto De Herrera 592—Asunción)
Phone: 8267
Cable: ALBATROS ASUNCION
Pres.: Mr. Walter Thiede
Labels (others): Archiv-Produktion, Coral, Deutsche Grammophon, M.G.M., Polydor, United Artists, Verve.

PHILIPS DEL PARAGUAY S.A.—Casilla Correo 605—ASUNCION
(Gral. Diaz. 226—Asunción)
Phone: 6919
Cable: PHILIPS ASUNCION
Pres.: Mr. J. F. Alexander
Labels (others): Philips

PERU

RECORD MFRS
EL VIRREY INDUSTRIAS MUSICALES S.A.—Avenida Mexico 238—Balconcillo—LIMA
Phone: 44350, 46479
Cable: VIRREY LIMA
Pres.: Mr. Polidoro Garcia
Labels (domestic): Philips, Virrey
Labels (others): Archiv-Produktion, Coral, Decca, Deutsche Grammophon, Disneylandia, Fuentes, Hispavox, Mercury, M.G.M., Peerless, Polydor, Sonus, United Artists, Verve, Vista

FABRICANTES TECNICOS ASOCIADOS, S.A. (FTA)—Apartado 3662—LIMA
(Km. 6 Autopista Ancon—Lima)
Phone: 47018
Cable: FTA LIMA
Pres.: Mr. Nilo Marchand Oneto
Labels (domestic): FTA
Labels (others): RCA Victor

INDUSTRIAL SONO-RADIO S.A.—1427 República Panamá—LIMA
Phone: 31854
Cable: SONORADIO LIMA
Pres.: Mr. Luis A. Aubry
Labels (domestic): Sono-Radio
Labels (others): CBS, Telefunken

INDUSTRIAS ELECTRICAS MUSICALES PERUANAS, S.A.—Apartado 67—LIMA
(Avenida San Martin No 1247—Lima)
Phone: 77399, 39139
Cable: IEMPSA LIMA
Pres.: Mr. Enrique Pardo Heeren
Labels (domestic): Cholita, Odeon
Labels (others): Capitol, Columbia, His Master's Voice, London, Musart, Odeon Argentina, Parlophone, Seeco.

SICA PERUANA S.A.—(FABRICA DE DISCOS MAG)—Apartado 3102—LIMA
(Oroya 224—Lima)
Phone: 36371, 35823
Cable: SICAPERU LIMA
Pres.: Mr. Manuel A. Guerrero
Labels (domestic): Mag
Labels (others): Audio Fidelity, Carisch, Chantecler, Epic, Montilla, Zafiro.

PHILIPPINES

MUSIC PUBLISHERS
PIONEER SONG LYRIC PUBLICATIONS INC.—P.O. Box 1309—MANILA
(1627-1631 Soler Street—St. Cruz—Manila)
Phone: 3-11-69
Cable: PISOLPI MANILA
Pres.: Mr. Filomeno P. Campaño

SUAREZ MUSIC CO.—28 Prosperidad St.—Tugatog—MALABON—Rizal
Phone: Manila 5-82-68
Pres.: Mr. Simplicio U. Suarez

RECORD MFRS

DYNA PRODUCTS, INC.—P.O. Box 3112—MANILA
(135 Second Avenue, Cor. D.—Auiuo St.—Grace Park—Caloocan City)
Phone: Manila 4-64-23, 2-29-74
Cable: DYPRO MANILA
Pres.: Mr. Albert Tan
Labels (domestic): Dyna
Labels (others): ABC-Paramount, Angel, Cadence, Cameo/Parkway, Columbia, Dolton, Hickory, His Master's Voice, Liberty, Odeon, Parlophone, Pathé, Pye, Stateside, Tamla/Motown

FEDERAL MANUFACTURERS—P.O. Box 2539—MANILA
(791 Ongpin Street—Manila)
Phone: 3-12-48
Cable: FEDERMA MANILA
Pres.: Mr. Pablo Chua Thiam Gi
Labels (domestic): Fama
Labels (others): Canadian-American, Caprice, Challenge, Colpix, Congress, Somerset-Sonorod.

FILIPINAS RECORD CORP.—131 Del Monte Avenue—QUEZON CITY
Phone: 6-27-60
Pres.: Mr. Manuel P. Villar
Labels (others): RCA Victor

MARECO, INC.—131 Del Monte Avenue—QUEZON CITY
Phone: 3-11-83
Cable: VILMARECO MANILA
Pres.: Mr. José P. Villar
Labels (domestic): Mobuhay, Villar
Labels (others): CBS, Command, Dot, Epic, Grand Award, Kapp, Laurie, M.G.M., United Artists, Warner Bros.

Italian Recording Studios

AMBROSIO Ing. F.
Via Brasile 9
Limite (Milano)
ANGELICUM
Piazza Sant'Angelo 2
Milano
CARISCH
Via Monviso 17
Milano
DURIUM S.p.A.
Via Pastrengo 16
Milano
FONIT-CETRA S.p.A.
Via Meda 45
Milano
FONIT-CETRA
Via Nicola de Cesarini 3/a
Roma
FONIT-CETRA
Via Bertola 34
Torino
FONOCCLAMOR
Via C. Botta 11
Roma
FONOLUX
Piazza Cinecittà
Roma
FONORAMA
Via Barletta 11
Milano
FONOTECNICA
Via Leopardi 25
Milano
INTERNATIONAL RECORDING S.p.A.
Via Cesare Balbo 5
Roma
VOCE DEL PADRONE-COLUMBIA-MARCONIPHON S.p.A.
Via S. Eufemia 25
Milano
MEAZZI F.lli
Via Piatti 6
Milano
MESSAGGERIE MUSICALI
Galleria del Corso 2
Milano
MICROPHON RECORD
Via Mantova 10
Milano

MICO INDUSTRIES, INC.—P.O. Box 2364—MANILA
(661-667 Sales Street—Manila)
Phone: 3-82-48
Cable: MICOINDUST MANILA
Mgr.: Mr. Eusebio Contreras
Labels (domestic): Mico
Labels (others): Capitol, Musart, Parlophone.

SUPER RECORD CO.—252 Escolta Street—Suites 301-303 Escolta Building—MANILA
Phone: 3-85-83, 3-73-22
Cable: SUPER MANILA
Pres.: Mr. Sian Yok Cheng
Labels (domestic): Super
Labels (others): Mercury, Smash, Wing

TONVEL, INC.—Room 316 de Leon Bros. Bldg.—Corner Raon & Rizal Avenue—MANILA
Cable: TONVEL MANILA
Pres.: Mr. Tony Velarde
Labels (domestic): Manila, Tonvel
Labels (others): Hit, Ritz, Triola, Variety.

PRESSING PLANTS

MICO INDUSTRIES, INC.—P.O. Box 2364—MANILA
(661-667 Sales Street—Manila)
Phone: 3-82-48, 3-69-30
Cable: MICOINDUST MANILA
Pres.: Mr. Eusebio Contreras

POLAND

EXPORT & IMPORT
FOREIGN TRADE ENTERPRISE ARS POLONA—Kra-kowskie Przedmiescie 7—WARSAW
Phone: 26-48-31
Cable: ARSPOLONA WARSAW
Pres.: Mr. Teodor Brachmanski
Only organization to be contacted in questions of export or import of ready-made cultural goods (records and sheet music editions).

MUSIC PUBLISHER

POLSKIE WYDAWNICTWO MUZYCZNE (PWM)—Al. Krasinskiego 11—KRAKOW
Phone: 252-14
Pres.: Mr. Tadeusz Ochlewski

RECORD MFRS

P.P.POLSKIE NAGRANIA—P.O. Box 996—WARSAW
(Długa 5—Warsaw)
Phone: 31-32-31
Cable: POLNAG WARSAW
Pres.: Mr. Pawel Kruk
Labels (domestic): Muza, Pronit, Verlon

PORTUGAL

COLLECTING SOCIETIES
S.E.C.T.P.—SOCIEDADE DE ESCRITORES E COM-POSITORES TEATRAIS PORTUGUESES, S.C.A.R.L.—Avenida da Duque de Loulé, 111, 1°—LISBON 1
Phone: 49870, 731656, 49429, 46250, 57613
Cable: AUTORES LISBON
Pres.: Dr. José Galhardo
Mechanical Licenses & Performing Rights Society

MUSIC PUBLISHERS

EDICOES MUSICAIS TRIUNFO—309 Praça do Muni-cipio—PORTO
Phone: 21445, 33624, 32462
Cable: RATRIL PORTO
Pres.: Mr. José Vazim, Mr. Rogério Leal

VALENTIM DE CARVALHO, LDA—Caixa Postal 2149—LISBON
(Rua Nova do Almada, 97—Lisbon)
Phone: 367051
Cable: TIM LISBON
Pres.: Mr. Rui Valentim de Carvalho

PHONOGRAM
Piazza Cavour 2
Milano

PHONOTYPE RECORD
Via E. De Marinis 4
Napoli

RAIFON
Viale Settembre 17
Trieste

RCA ITALIANA S.p.A.
Via Tiburtina Km. 12
Roma

REFERT
Via Alessandria 9
Parma

RICORDI G. & C.
Via dei Cinquecento 1
Milano

SAAR
Via Gramsci 20
Pero (Milano)

SERVIZIO REGISTRAZIONI SONORE
Via S. Radegonda 11
Milano

STEREO S.r.l.
Via Aurelio Saffi 11
Milano

STUDIO ARLECCHINO
Corso Vittorio Emanuele 11
Milano

STUDIO REGSON
Via Ludovico il Moro 57
Milano

STUDIO SETTE
Corso Venezia 7
Milano

TECNIPHON SALA BAROZZI
Via Vivaio 7
Milano

TITANUS
Via Somma Campagna 28
Roma

VIS RADIO
Via Pupa Caiafa 36
Napoli

ITALY— The Past 12 Months

(Continued from page 102)

Another top event of the month was the Italian tour of The Beatles, which had great success especially in Milan and Genoa. Last leg of their Italian visit was Rome, where they performed the night of June 27. The Beatles' disks are distributed in Italy by Carisch. Unfortunately, Italian TV refused to present The Beatles and this is the reason why the promotional power of their tour was so limited.

Third interesting event of the month was the International Light Music Show of Venice organized by Gianni Ravera. Among the foreign talents who took part in the contest was Petula Clark, (SAAR) Bobby Vinton (Dischi Ricordi/CBS) The Minstrels (Dischi CBS), Yukari Ito (CGD Internationale). Among Italian stars: (Clan), who introduced, by the way, his new disk for the summer season, Mina (RiFi), Adriano Celentano and Peppino Di Capri (Carisch).

The MRC line in South America went to Philips. Announcement was given by Piero Galloti, manager of the Italian firm.

Bruno Pozza, general manager of Clan Glenetano, informed CB about the finalization of the deal with the Russian State Record Company for the representation, reproduction and distribution in Italy of this Russian catalog of classical music.

Durium has announced that Pye Records of London will distribute their catalogue in England.

Edoardo Vianello, one of the top artists of RCA Italiana, was awarded with a second gold disk for two million records sold.

RECORD MFRS

ARNALDO TRINDADE & CO., LDA—Caixa Postal 139—PORTO
(Rua de Santa Catarina, 117—Porto)
Phone: 21232, 29513, 29514
Cable: RADILECTRA PORTO
Pres.: Mr. Arnaldo Trindade
Labels (domestic): Orfeu
Labels (others): Durium, Made, Pop, Vogue

CASA FIGUEIREDO—Rua de Santo António, 74—PORTO
Phone: 21293
Pres.: Mr. José A. G. De Figueiredo
Labels (domestic): Rapsódia
Labels (others): Amadeo, Celra, Chant du Monde, Fonit

(Continued on page 111)

CANADA—The Past Twelve Months

JULY 1964—Rodeo label stars, The Gem Tones, set to appear at World's Fair. Cathy Carr debuts new RCA Victor album, "Songs For Sentimentalists", a good collection of standards. Marvelettes appear at Montreal's Mocambo, do big business with Tamla single, "You're My Remedy". "Like Young" radio segment hosted by Dave Boxer debuts on Montreal's CFCE. Proves to be first class exposure vehicle for record product. Causes other city stations to re-evaluate programming of current singles. C-FOX Radio introduces its twenty-four hour a day Country Music format to Montreal listeners. Bill Smithers at Quality in Montreal reports hit-like action in his territory on "Yours" and "Jolie Jacqueline" by Lucille Starr. Chess, Checker, Argo lines switch to Phonodisc for Canadian distribution.

AUGUST 1964—Mike Stephens introduces Discotheque trend to Montreal, debuting his "21 Discotheque" at Montreal's Grand Motor Hotel. First reports begin to reach rest of country from Reg Ayres in Winnipeg on big action on release, on Quality, by Chad Allen And The Expressions, entitled, "Stop Teasing Me". Canadian charts bulge with Chuck Berry releases, both his own records and records by other artists on his compositions. Deejays flip for new Nat Cole LP containing his versions of songs from "My Fair Lady". Billy J. Kramer does big chart business with "From A Window". Canadian deejays create demand for "Little Honda", an item in their latest LP. "G.T.O." by Ronnie And The Daytonas hits big in Canada. Bob Gillies returns to Montreal and CKGM from the U.S.A. to host station's 6-9 P.M. segment. Elvis Presley hits the Canadian chart scene in a big way with his RCA Victor updating of "Such A Night". CKY, Winnipeg introduces a personal friend of The Beatles, Pat Harrison, as one of their regular air

personalities. Englishman draws fantastic response from listeners. John Porteous at Arc makes Canadian wax world aware of an exciting new talent, Terry Black from Vancouver. His initial Arc outing, "Unless You Care", starts very big in Canadian west. Dave Patrick becomes host of CJAD's all night show in Montreal. "Pretty Woman" by Roy Orbison becomes one of London's biggest singles in years. Ted Daigle takes over control of Ottawa-area nightspot, converting it to strict country music policy.

Walt Grealis' R.P.M. debuts new magazine format. CHUM-Toronto increases power to 50,000 watts. The Couriers appear in Montreal nitery as RCA Victor releases folk group's first LP. Bob Martin and Claude Renallo of Columbia host swingin'est-ever reception for Andy Williams in Ottawa during star's P.A. stand at Central Canada Ex. Serious injuries sustained in auto accident by CFRA-Ottawa, Music Director, Carol Vallillee. Joyce Germaine records London side, "The Beatles Are Coming", produced by Dave Leonard, side does very well in Montreal and area. Diane Miller debuts first Columbia single, "Baby That's The Way It Goes". TV star visits many Canadian spinners to promote her disc. RCA Victor begins to chalk up chart action with Gale Garnett outing, "We'll Sing In The Sunshine". Lee Farley leads way onto Canadian charts from coast to coast for Chad Allen's Quality outing, "Stop Teasing Me". Lee also starts considerable eastern Canadian action for a chart buster from west coast, "Automatic Reaction" by Nino & The Ebb Tides. Pioneer Canadian record man, Aaron Lipsin introduces new Montreal based record company, Almada Corporation. "Elvirita", recorded in Italy on Durium is released in Canada by London. Artist, Elario Locano has been headliner for months at Montreal night spot. General Manager's post at Montreal's CKGM-FM

is taken over by lovely, Lori Dempsey, succeeding exiting Bill Ballantyne who moves to exec post with CKFM in Toronto.

SEPTEMBER 1964—RCA Victor national sales meeting at firm's plant in Smiths Falls, concludes with spectacular cross Canada phone, sales blitz, resulting in new product for Fall hitting dealers shelves right across the country on day after Labour Day. Bill Fisher, Allied topper, in high chart gear with one Pye hit after another. "Have I The Right" by The Honeycombs and "You Really Got Me" by The Kinks rate as biggest sellers ever for Allied. "Come A Little Bit Closer" by Jay And The Americans rolls into high sales and chart gear for Compo right across Canada. Dean Martin follows suit with his second-in-a-row chart outing, "The Door Is Still Open". The beautiful doll-about-discs on the Toronto scene, Millie Moriak returns to the wax wars after too long an absence as Publicity Officer for Toronto night spot specializing in pop record acts. TV-deejay John Pozer begins newly formatted, "Saturday Date" Channel 13, show on Ottawa's CJOH. RCA Victor debuts new label color and design with release of Rita Pavone ballad, "Wait For Me". Capitol Records' comic, Ross Smith begins new comedy radio series, "Fun Calls" on Montreal's CKGM. Another Elvis Presley single begins to make Canadian chart noise for RCA Victor. "Ain't That Lovin' You Baby" b/w "Ask Me" appears on chart after chart. Veteran radio man Gary Parkhill takes his leave of the Canadian Lakehead and CJLX to assume new on-air duties at CFCN Radio and TV in Calgary. His post of Program Director at the Lakehead station is taken over by Fred King. Paul White at Capitol does some (what turned out to be premature) tub thumping for Herman's Hermits, then distributed in Canada on his label. Another

of Paul's English giants was "Doo Wah Diddy Diddy" by Manfred Mann. Ronnie Fraser makes his first venture into the world of wax with a Dave Leonard-produced side, "Stop Look Listen". Side is picked up for Canadian distribution by Columbia. Fred Rifka returns to his Montreal starting point at London's H.Q. after a western Canadian stint as a label exec. Harry Grief exits Music Director post at Montreal's CFCE. Newsman Campbell MacDonald leaves longtime department head job with CFRA, Ottawa to enter P.R. business on his own in Nation's Capital. Frosty Forst leaves C-FUN, Vancouver for CKNW, same city. M.D.'s post at Vancouver pop-powerhouse, C-FUN is handed to Tom Peacock. Andy Nagy at Quality in Montreal reports big chart action throughout his territory for "Shaggy Dog" by Mickey Lee Lane. Bobby Curtola begins eastern swing of a cross-Canada tour with Ottawa and Montreal S.R.O. P.A.'s.

OCTOBER 1964—CKY-Winnipeg air personalities host Gale Garnett during lark's Winnipeg club date. She is presented with key to the city by Mayor Juba. Canadian record-biz vet, Liam Mullan takes over London-based P.R. job with Epstein office, going on the road with The Beatles. Gerry And The Pacemakers, Billy J. Kramer and Terry Black play before sell out Toronto audience in CHUM-sponsored show. Andy Kim announces new deal to release under the Red Bird banner. The Esquires appeared in Montreal with the Dave Clark Five, and proved to be a big hit as they did their new Capitol single, "So Many Other Boys". London's Hal Ross made a presentation of a gold disc to Roy Orbison marking 100,000 plus sales in Canada on "Pretty Woman".

C-FUN, Vancouver deejay, Tom Peacock debuts new CHAN-TV Dance (Continued on page 106)

LET OUR SUCCESS STORY BE YOURS

LONDON RECORDS

LONDON
RECORDS

SELLS

CANADA

AGGRESSIVE, EFFECTIVE, ENTHUSIASTIC, COAST TO COAST
DISTRIBUTION AND PROMOTION!

CONTACT US NOW IF YOU WANT MAXIMUM SALES IN
THE *UNIQUE* CANADIAN MARKET

PHONE, WIRE, TELEX OR WRITE

LONDON RECORDS OF CANADA LTD.

190 GRAVELINE RD.

PHONE 631-2061

ST. LAURENT, P.Q.

TELEX: 012384

CANADA—The Past Twelve Months

(Continued from page 105)

Party show. "Thank You" by Harry Simeone Chorale is given heavy air exposure by CKGM's Morning Mayor, Doug Burrows, to the point that side is lifted from Mercury LP, resulting in excellent Montreal and area single sales. Ruby And Romantics do big business during Montreal stand at Johnny Rougeau's Mocambo Club. Curtola cross-Canada tour, west to east, concludes in Newfoundland after total of 118 days, playing to over 350,000 Canadian youngsters. RCA Victor introduces its new Canada-International line at reception aboard Cunard liner in Montreal harbour.

NOVEMBER 1964—Columbia unveils sensational new album package spotlighting Phyllis Marshall. Columbia takes over Canadian distribution rights for product originating with Musicor in U.S. Keith Ashdown announces decision to exit London Records' H.Q. in Montreal to return to his native Australia. Lee Mandell, Liberty west coast exec, returns to Montreal on distributor visit. He previews sensational album releases by Sunset Strings and Johnny Mann Singers. "Lumberjack" by Hal Willis develops into national breakout for Quality. "Hawaii Tattoo" by Waikikis becomes sales giant on Kapp in Toronto and shortly moves into top chart spots all across Canada. CHUM, Toronto, creates considerable stir with teenaged listeners as they banned records by The Rolling Stones from the outlet. "The Jerk" by The Larks begins to happen big for Quality. Dance craze inspired by record or vice versa sweeps country. Connie Francis LP, "A New Kind Of Connie" makes the scene and starts selling like hotcakes. Dave Leonard, Montreal record producer, sustains serious injuries in auto crash, while on promotion jaunt on behalf of Ronnie Fraser's "Stop Look Listen".

CKOY, Ottawa spinner, Nelson Davis, leads the way on air play for Marianne Faithful record outing, "As Tears Go By". "Happy Birthday" on Decca by Loretta Lynn, written by Toronto deejay, Ron Kitson, shows up on charts everywhere. Montreal recording studio "Marko", headed up by Mark Odette turns to recording and mastering of music. Chief Operator in the newly-oriented studio is Don Hahn. Hal Ross, National Field Rep., at London, begins 60 member, Canada wide Youth Club to preview label's product and indicate acceptance on market at large.

Tim Hudson begins new radio segments on Montreal's CKGM. Billed as "Lord Tim" he comes to the station after extensive experience in pop music biz in England, including production of hit single by Moody Blues, "Go Now". Canadian artists The Winmen, chalk up chart listings in several key centres with Ric outing, "Nickle Piece Of Candy". Vet Canadian record man, Carl Schmidt, debuts new record product in both U.S. and Canada by way of a Danco release featuring The Royal Jacks. Canadian distribution was set up through Carl's Canadian distrib operation, Fonorama. Apex Record man, Al Mair, debuts new weekly news sheet, The Cash-A-Gram. CKPT, Peterboro spinner, Keith Randall relocates to CFCF Montreal and the two man morning show, sharing a mike with vet Franklin Armstrong. Paul White really starts plugging the Garry Ferrier Xmas novelty, "Ringo Deer". The Hawk line is taken over for Canadian distribution by Capitol. Initial releases under the Ronnie Hawkins banner show up well on Canadian charts, with Robbie Lane's "Ain't Love A Funny Thing", leading the way. Montrealer Mark Thatcher, currently clicking with his debut U.A. release "Be My Love", visits Montreal from his New York post with the Nevins-Kirshner office. Joan Clarkin

takes over hostess spot on long running Montreal teen-type TV'er, "Like Young" over CFCF-TV. Tom Shannon moves to CKLW in Windsor after a lengthy stay in Buffalo, New York. New national promotion man at Arc is Ken Warriner. He takes over from John Porteous who moves into the firm's custom sales division.

DECEMBER 1964—Chad Allen and his group appear in SKY Sponsored Liverpool Sound, Spectacular with Manfred Mann and Peter and Gordon. Jim Corbett and Harold Pounds very excited about coast to coast reaction on "Amen" by The Impressions. Meanwhile, label's outing by Johnny Cowell, "Winds Of Chance" begins to happen in several key markets. Big action noted in several spots on Atlantic outing by Jo Ann Campbell and Troy Seals, "I Found A Love," particularly in Montreal following nitery P.A. by husband and wife singing duo. Bill Smithers squires The Canadian Sweethearts, Lucille Starr and Bob Regan, around Montreal during their nitery stand in the City. "Colinda" single by Lucille and Sweetheart's LP received much air play. Frank Henry goes to work in a big way on the Gary Ferrier Xmas novelty "Ringo Deer." At the same time the charming lady of the Montreal Capitol Tower, Monique Leroux, was busily lining up turntable time for an outing by Les Cailloux, a big French-language hit, "Joseph Avec Marie." Lee Dunbar exits CFCF Radio, Montreal, returning to his native U.S. Rick Smith also exits Montreal's CKGM to take over News Director's spot at CJRN, Niagara Falls, "Giselle's" weekly news sheet debuts from Quality. Girl scribe's identity remains Lee Farley's top secret. Deejay Ron Kitson leaves Toronto's C&W outlet, CFGM, to shuffle off to deejay spot in Buffalo. New CBC-TV'er aimed at record buying public debuts in Montreal. "Teen '65,"

hosted by June Mack and Rod Campbell, becomes City's second teen-type TV show. Major staff shakeup hits Montreal's pop music outlet, CKGM. Exiting station en masse, Doug Burrows, Dick Varney and Johnny Murphy. RCA Victor sets production record with recording, pressing and distributing of French-language original caster, "Le Vol Rose Du Flament." Catherine McKinnon LP released by Arc, and instantly develops into big sales item. Pye product very big for Bill Fisher at Allied as year comes to a close. Liam Mullan returns to Canada from his promo post with the Epstein office in Great Britain.

JANUARY 1965—Pat Hervey's new single, "Think About Me," wins cross Canada deejay support. R.P.M. Year End Music Poll results announced. Cash Box Canadian Editor John Murphy, named "Man Of The Year" in Canadian music biz. New P.D. makes scene at CKOC, Hamilton, in person of Doug Alexander late of CKCK in Regina. Petula Clark appears in Montreal, is feted at reception. "Downtown" tops charts from coast to coast. Al Boliska puts his "World's Oldest Gags" into national syndication. Keith Rich returns to Toronto radio scene and CKEY after lengthy sojourn at WNBC, New York. "Go Now" by Moody Blues introduced to Canadian air waves by CKGM's Tim (Lord Tim) Hudson begins to happen. Jacques Gagne is named A&R top man at Columbia in Montreal, to specialize in French-language product. Capitol signs two top Canadian record stars Wes Dakus and Barry Allen. The Big Town Boys debut on RCA Victor with a strong commercial outing, "Put You Down." RCA Victor releases exceptional album on its International label by the Dosco Male Chorus, entitled "Men Of Steel." Rudy Assaly at Musicmart reports much dealer and consumer interest in an import on Planet

(Continued on page 107)

Why

set up an office,
whip up a sales force,
woo thousands
of dealers,
learn French,
promote,
distribute,
advertise—
why bother
to manufacture?



If you want to
sell records
in Canada,
let us get your
ulcers
for you.

**Only RCA Victor has COMPLETE
facilities for manufacturing and
marketing records in Canada.**

RCA VICTOR COMPANY, LTD. 1001 Lenoir St., Montreal, Canada
514-933-7551

CANADA—The Past 12 Months

(Continued from page 106)

by The Guenter Kallman Choir, "Elisabeth Serenade." Broadcast vet Bob Walters doubles in brass as sales rep for Musimart in Montreal. CFCF deejay, Dave Boxes journeys to Britain returning with much material from red hot British disc scene for his Montreal nightmer. New arrivals at Montreal's CKGM are sportscaster Danny Gallivan and vet air personality, Ned Conlon. Red Leaf Associates is formed to distribute under one label the record product of three major independents. Distribution on a nation wide basis set up through established channels of Raligh Record Sales Ltd. Gene Pitney plays to large crowd at Ottawa, is hosted by Columbia's Claude Renallo at reception immediately after show. Frank Cantar exits Ottawa's CKPM to take over new duties on CFMO, same city. J.B. And The Playboys amaze industry with their organization and sound as the act debuts on RCA Victor, called best organized act ever in the Canadian music biz. Record Biz vet, Wray Rutledge now runs mobile one-stop service throughout Southern Ontario. Russ Simpson CKLG, Vancouver M.D. adds network TV'er to his activities. Peter Paul and Mary record a Gord Lightfoot tune, "For Lovin' Me," chart action is hot and heavy.

FEBRUARY 1965—Gerry Wolff introduces a charming and talented girl singer on the label that bears his name, Rita Curtis. "Springrains" gets a lengthy chart ride at many of the top C&W stations. Capitol's French-language subsid., Pathe releases first single outing by Richard Proulx, expected to follow up his initial French release with a follow up in English on Capitol. "Do What You Do Do Well" begins to hapen for Ned Miller shortly to become another big seller for the artist in Canada. Phil Najovits takes over as General Sales Manager at Allied from Bill Fisher. Najovits, late of Phonodisc's Montreal branch, inherits a pot full of red hot sellers on Pye. Quality Records, through Harold Winslow, make presentations to six Canadian radio stations for their development of made in Canada record product from the various Quality lines. Vancouver deejay, Fred Latrimo, bows in as a recording artist with his debut release on London. Mike Marshall, highly rated Edmonton air personality shifts location from CJCA to CHED, same city. Vet radio man, Dean Hagopian takes his leave of Ottawa's CKOY and the broadcasting business. Apex's Al Mair elated over results of his lengthy campaign to break the chart barrier with "I Can't Explain" by The Who on Decca, now well established on most of the Country's play lists. Maritime disc stars, The Beavers are signed by Epic Records for American release of their discs. They change name of group to The New Scotians.

MARCH 1965—Canadian Association Of Country Music Entertainers holds founding meeting in Toronto. Exec changes at CJCA, Edmonton have long time M.D. Harry Boone becoming P.D. of the pop music outlet, succeeding Dalt Elton who is promoted to Station Manager. Hal Ross leaves his National Promotion post at London to become Montreal Branch Manager for Phonodisc. Another Montrealer long associated with all facets of the music business, Dav Grief, relocates from his radio sales position to become General Sales Manager of The Laval Record Company. Sales action develops on Arc satirical set, "Oh Oh Canada" by The Brothers In Law. Biggest novelty hit in a long time builds for Harold Pounds at Sparton in "Ten Little Bottles" by Johnny Bond. From California comes a very commercial up-dating of "That'll Be The Day" released in the U.S. on Chattahoochee and on Gaiety through London in Canada. Picks and play in large quantities for the good outing both in Canada and the U.S. Kingston deejay vet, Bryan Olney pens good song recorded by The Four 'Em, "While I'm Away" shows good potential in several Canadian markets. Dennis Corrie leaves his M.D. post at CKY Winnipeg to take up new on-air

role at CFAC in Calgary. "Never Send You Flowers" by The Paupers on Red Leaf shows very well for its producers, The Mostoways, on Toronto air play and sales. Long time fixture on the Canadian music scene, Don Wayne relocates to sunny Cal., and a spot with the Dick Clark organization. Gerry Gordon moves from the Montreal Photodisc sales force to join ex-boss Phil Najovits at Allied. Bill Smithers confirms action reports out of Montreal on "Mrs. Brown" by Herman's Hermits. Side breaks wide open right across Canada for Quality. Sandy Shaw and Adam Faith visit Montreal on promo tour for their respective record outings. Red Leaf's hot attraction David Clayton Thomas appears on N.B.C.'s "Hullabaloo." Canadian-born artist, Kenny Chandler scores in several key markets with his Epic outing, "Sweet On Susie." Bill Fisher, ex-Allied head man, rejoins the wax world, teaming up with Art Young to run a firm billed as "Fi-Sound." First product produced by the firm offers instrumental stylings of Jimmy Torres. George Taylor at Rodeo doing big business with hot American master by The Hi Lites, "Hey Baby." Brian Browne, well known Canadian jazz pianist, records album for RCA Victor after relocating in Toronto's Park Plaza Hotel. Phonodisc acquires Paula-Jewel line for Canadian distribution. Pierre Lalonde starts some considerable chart action with his good ballad outing, "Forever." "Me And You" by The Regents starts to move on the Quality scene, chart listings are numerous for the good made-in-Canada sound. David Clayton Thomas appears with The Rolling Stores P.A. in Toronto. R.P.M. Directory proves to be outstanding publication for Canadian music trade.

APRIL 1965—Another Gord Lightfoot composition, "Ribbon Of Darkness" stirs up considerable chart action by a way of a Marty Robbins, Columbia outing. George I. Harrison appointed V.P. at RCA Victor Co., Ltd., remaining as General Manager of the Company's record division. First Wolff label product to be distributed by RCA Victor is "Say Baby" By Dee And The Yeomen. "The Swing Set" news letter and chart covering the Ottawa scene debuts. Reg Ayres, Quality's man in Winnipeg ignites national action on track in new album by Chad And The Ex-

pressions—gets single released on "Tossin' and Turnin'." Vet C&W lark, Myrna Lorrie is featured on strong Sparton single, "Can't Live With Him." Don Franks LP is released on Kapp. Single lifted from the set—gets good air action on better music formats. Freddie And The Dreamers finally make it big on the Canadian chart scene, fulfilling a two year old prediction of Capitol's Paul White. Strong Canadian teen single, "Mynah Bird Hop" by The Mynah Birds on Columbia makes some chart noise in several areas. Carl Schmidt of Fonorama has some good material in his most recent batch of singles under the Danco banner. The Allan Sisters win good solid deejay support with their first class Red Leaf outing, "Remember The Face." Duke Ellington takes part in a birthday surprise party for him conducted on the air at Montreal's CKGM. Compo's Barry Paine originates for many of the Duke's friends and associates to phone their greetings to him on the air from all over North America. Paul Anka films CBC TV spectacular in his hometown, Ottawa. Gord Lightfoot picks up several key chart listings with his good outing on Warners. "I'm Not Sayin'." Gord is feted at Toronto reception.

MAY 1965—Dave Leonard is named Production Manager at Allied Records. He maintains his interest in his own production firm. Monticana Records. Wholesale Appliances Ltd., Vancouver take over the lines formerly handled on the west coast City by Aragon Enterprises Ltd. Monticana production, released in Canada on Quality, "She's Mine" by Bartholomew Plus Three gets much air and chart action in Montreal via the Dave Boxer CFCF show. The Staccatos of Ottawa follow up their initial wax outing, "It Isn't Easy", with their first under the Capitol banner, "Small Town Girl." Sanda Selsie does well with her Columbia C&W sound, "I

(Continued on page 111)

**CANADA'S
LARGEST
ONE
STOP
ALL LABELS**

45 and 33 1/3 RPM
available



**MUSIQUE
SERVICE
MUSIC INC.**

189 Rockland rd.
Town of Mount Royal
Montreal 16
Phone: 731-3462

Branch:
25 Richelieu, Quebec
Phone: 524-1294

CANADA'S LEADING: INDEPENDENT RECORD PRODUCERS, RECORDING STUDIOS, TALENT REPRESENTATIVES, RECORD LABEL, MUSIC PUBLISHERS



ONTICANA
RECORDS and ENTERPRISES

P.O. BOX 323, MONTREAL 3, QUE., CANADA. (514) 739-8935 737-9200

**Top Distribution
and representation
to the major independents**

COMPO * CANADA

Synonymous with the best in manufacturing,
distribution and promotion—coast-to-coast in Canada

APEX DIVISION - THE COMPO COMPANY LTD.

2377 REMEMBRANCE STREET, LACHINE, MONTREAL, QUEBEC • 514-637-2561

Telex: 01-20122

TWX: 610-422-3064

Bob Chislett, General Manager

Phil Rose, Sales Manager

Allied

RECORD CORPORATION

Manufacturer and Distributor

Exclusive distributor of the following labels:

ROULETTE	MAINSTREAM	BANG
PYE	FONORAMA	SABINA
ELEKTRA	LOMA	LISTEN AND LEARN
NONESUCH	LUMBY	TARTAN
TIME	SIMON SAYS	ARAVEL

BRANCH OFFICES:

Ottawa:	Toronto:
400 Industrial Avenue	40-12 Barbados Blvd.,
Telephone: (613) 731-3310	Telephone: (416) 267-4460

Vancouver:
8401 Fraser St.

PRESIDENT:
Phillip DeZwirek, Ottawa
Telephone: (613) 731-3310

GENERAL MANAGER:
Jack Boswell, Toronto
Telephone: (416) 267-4460

THE TOP HITS OF '65 IN CANADA

These Records Are Listed Alphabetically By Title on Information Supplied By Manufacturers and Distributors

TITLE	ARTIST	LABEL
A La Fin De La Soiree	Michel Richard	Trans
As Tears Go By	Marianne Faithful	London
Aventures Dans Les Isles	Bob Robie	Rusticana
Al Di La	Ray Charles Singers	ABC-Paramount
Amen	The Impressions	ABC-Paramount
Ain't That Loving Yo Baby	Elvis Presley	RCA Victor
Aide Moi Cherie	Les Excentriques	RCA Victor
All Beatle Singles	The Beatles	Capitol
Before And After	Chad & Jeremy	Columbia
Bread and Butter	The Newbeats	Hickory
Bluessette	Ray Charles Singers	Command
Birds And The Bees (The)	Jewel Akens	Era
Baby Love	The Supremes	Motown
Back In My Arms Again	The Supremes	Motown
Count Me In	Gary Lewis	Liberty
C'est Toi Mon Idole	Donna Hightower	London
Ce Sacre Vieux Soleil	Bob Robie	Rusticana
Concrete And Clay	Unit Four Plus Two	London
Carol	Tommy Roe	ABC Paramount
Can't You Hear My Heartbeat	Herman's Hermits	MGM
Crying In The Chapel	Elvis Presley	RCA Victor
Chapel Of Love	Dixie Cups	Red Bird
Crooked Little Man	Serendipity Singers	Philips
Ca Va T'Aime	Michel Richard	Trns. Can.
Come See About Me	The Supremes	Motown
Do You Wanna Dance	Beach Boys	Capitol
Down In The Boondocks	Billy Joe Royal	Columbia
(2) Do Wha Diddy—Do What Diddy	Tony Roman—Manfred Mann	Jupiter-Capitol
Do The Clam	Elvis Presley	RCA Victor
Dans Le Temps	Petula Clark	Vogue
Dear Heart	Jack Jones	Kapp
Donna	Ritchie Valens	Del Fi
Ecoute Ce Disque	Sheila	Philips
Engine Engine #9	Roger Miller	Smash (Mercury)
Easy Question	Elvis Presley	RCA Victor
Ferry Across The Mersey	Gerry/Pacemakers	Capitol
Fume Fume Fume	Les Excentriques	RCA Victor
Four Strong Winds	Bobby Bare	RCA Victor
G.T.O.	Ronnie & Daytonas	Mala
Game Of Love	Wayne Fontana	Fontana
Give Me Forty Acres	The Willis Bros.	Starday
Gator Tails And Monkey Ribs	The Spats	ABC Paramount
Go Now	The Moody Blues	London
Goodnight	Roy Orbison	Monument
Help Me Rhonda	Beach Boys	Capitol
Hello Dolly	Louis Armstrong	Kapp
Henry The Eighth	Herman's Hermits	MGM
Hey Bobba Needle	Chubby Checker	Parkway
Haunted House	Gene Simmons	Hi
Heart Of Stone	The Rolling Stones	London
Here Comes The Night	Them	Parrot
Hush Hush Sweet Charlotte	Patti Page	Columbia
I Go To Pieces	Peter & Gordon	Capitol
I'M Telling You Now	Freddy & Dreamers	Capitol
I Feel That I've Know You Forever	Elvis Presley	RCA Victor (EP)
I Can't Help Myself	The Four Tops	Motown
I'm Into Something Good	Herman's Hermits	MGM
Il Faut Se Quitter	Les Million-Airs	London
It' All Over Now	The Rolling Stones	London
It's Not Unusual	Tom Jones	Parrot
I'll Never Find Another You	Seekers	Capitol
I'll Be There	Gerry/Pacemakers	Capitol
Joli Jacqueline	Lucille Starr	A&M
Je Deviens Fou	Dominic	London
Je T'aime Plus Fort	Robert Gogoi	Philips
J'y Pense Et Puis J'Oublie	Claude Francois	Philips
Just Once In My Life	The Righteous Bros.	Philips
Keep Searchin'	Del Shannon	Amy
King Of The Road	Roger Miller	Smash (Mercury*)
Last Kiss	J. Frank Wilson	Josie (Jubilee)
Leader Of The Pack	Shangri Las	Red Bird
Little Honda	The Hondells	Mercury
Little Drummer Boy	Harry Simeone Chorale	20th Fox
Love Me With All Your Heart	Ray Charles Singers	Command
Little Old Lady From Pasadena	Jan & Dean	Liberty
Les Guitars Jouent	Johnny Hallyday	Philips
Le Penitencier	Johnny Hallyday	Philips
Les Parapluies De Cherbourg	Nana Mouskouri	Fontana
Marie—Toi	Aglae	DC
Ma Vie	Alain Barrier	RCA Victor
My Guy	Mary Wells	Motown
Mrs. Brown You've Got A	Herman's Hermits	MGM
Lovely Daughter	Millie Small	Smash (Mercury)
My Boy Lollipop	Johnny Rivers	Imperial
Midnight Special	Johnny Rivers	Imperial
Mountain Of Love	Johnny Rivers	Imperial
Maybelline	Donald Lauffrec	Jupiter
Manon Viens Danser Le Ska	Marc Gelinac	Figaro
Moira	Bachelors	London
Marie	The Byrds	Columbia
Mr. Tambourine Man	Bobby Vinton	EPIC
Mr. Lonely	Little Caesar	Red Leaf
My Girl Sloopy	The Consuls	Chess
No Particular Place To Go	Chuck Berry	London
No Arms Can Ever Hold You	Bachelors	
Ode To The Little Brown Shack	Billy Edd Wheeler	Kapp
Out Back	The Impressions	ABC Paramount
People Get Ready	Roy Orbison	Monument
Pretty Woman	Les Classels	Trans Canada
Qu'est Devenu Notre Passe	Nana Mouskouri	Fontana
Quatre Soleils	Dave Clark Five	Capitol
Realin' And Rockin'	Jan and Dean	Liberty
Ride The Wild Surf	Four Seasons	Philips
Rag Doll	You Know Who Group	Four Corners
Roses Are Red (My Love)	Lorne Green	RCA Victor
Ringo	The Drifters	Atlantic
Saturday Night At The Movies	Tony Roman	Jupiter
Sha La La	The Rolling Stones	London
Satisfaction	The Zombies	Parrot
She's Not There	Lucky Blanco	Fontana
Sur Ton Visage Une Larme	Sir Douglas Quintet	Tribe
She's About A Mover	Johnny Rivers	Imperial
Seventh Son	Guess Who (Chad Allen & Expressions)	Scepter/Quality
Shakin' All Over	Herman's Hermits	MGM
Silhouettes	Terry Stafford	Crusader
Suspicion	Jr. Walker & All Stars	Soul
Shotgun	The Supremes	Motown
Stop In The Name Of Love	Les Classels	Trans Canada
Ton Amour A Change Ma Vie	Shirley Ellis	Congress
The Name Game	Jack Jones	Kapp
The Race Is On	Lucille Starr	A&M
The French Song	Julie Rogers	Mercury
The Wedding	Guess Who (Chad Allen & Expressions)	Quality
Tossin' and Turnin'	Johnny Bond	Starday
Ten Little Bottles	Ray Charles	ABC Paramount
That Lucky Old Sun	Gary Lewis	Liberty
This Diamond Ring	The Rolling Stones	London
Tell Me	The Nashville Teens	London
Tobacco Road	The Rolling Stones	London
Time Is On My Side	The Rolling Stones	London
The Last Time	Donald Lautrec	Jupiter
Tu Dis Des Betises	The Zombies	Parrot
Tell Her No	Pierret Beauchamp	France-Canada
Tu Te Reconnaitres	Marianne Faithful	London
This Little Bird		

(Continued on page 108)



SPARTON RECORDS



**COAST TO COAST
DISTRIBUTION,
OVER 26 YEARS
OF REPRESENTING
TOP MAJOR AND
INDEPENDENT U.S.
LABELS**

**HAROLD POUNDS • MANAGER,
P.O. BOX 2125 • LONDON, ONT.**

SPARTON OF CANADA LIMITED—LONDON • TORONTO • MONTREAL

IF YOU WANT
ACTION
IN
CANADA

GET WITH

ARC
SOUND LIMITED

- PERSONALIZED REPRESENTATION
- IMAGINATIVE PROMOTION & PUBLICITY
- CREATIVE MERCHANDISING
- TOTAL NATIONAL DISTRIBUTION
- WELL-FINANCED, AND DYNAMIC ORGANIZATION

LARGE enough to do an excellent job on your labels

SMALL enough to give you concentrated personalized service

CONTACT:

PHIL G. ANDERSON, PRES.

W. R. "BILL" GILLILAND, V. PRES.

ARC SOUND LTD.

20 CRANFIELD RD.
TORONTO 16, ONT., CAN.

PHONE: 416-751-1613

CABLE: ARC SOUND

CANADA

Record Manufacturers

ALLIED RECORD CORPORATION
(Manufacturer)

8500 Delmeade Road,
Montreal, Quebec

ALLIED RECORD CORP.

2166 West Fourth Ave.,
Vancouver, B. C.

ALLIED RECORD CORP.

15 Fleury Place,
St. Boniface, Man.

ALLIED RECORD CORP.

40-12 Barbados Blvd.,
Scarborough, Ont.

ALLIED RECORD CORP.

400 Industrial Ave.,
Ottawa, Ontario

ARC RECORDS LTD. (Manufacturer)

20 Cranfield Road,
Toronto 16, Ontario

R. W. CRAWFORD LTD.

118 Albert Street,
Moncton, N. B.

TRANS CANADA RECORDS INC.

189 Rockland Rd.,
Montreal, Quebec

ARC RECORDS

1436 Erin Street,
Winnipeg, Man.

CENTRAL RECORD CO., LTD.

3631 Blackburn Rd.,
Calgary, Alta.

EMERSON SALES LTD.

1859 West Fourth Ave.,
Vancouver, B. C.

CANADIAN MUSIC SALES CORP.

(Manufacturer)
58 Advance Road,
Toronto 18, Ont.

EMERSON SALES LTD.

Vancouver, B. C.

CENTRAL RECORD CO., LTD.

Calgary, Alta.

LAUREL RECORD DISTRIBUTORS

P. O. Box 1021,
Winnipeg, Man.

MONTREAL MUSIC BAR

3431 Ontario Street East,
Montreal, Que.

CAPITOL RECORDS OF CANADA LTD.

(Manufacturer)
635 Queen Street East,
Toronto 8, Ontario

CAPITOL RECORDS OF CANADA

155 Port Royal West,
Montreal 11, Quebec

ELECTRICAL SUPPLIES LTD.

312 William Ave.,
Winnipeg, Man.

STERLING DISTRIBUTORS LTD.

308 Well Street, P. O. Box 1508,
Saskatoon, Sask.

VAN DUSEN BROS.

10528-123rd. Street,
Edmonton, Alta.

SELECT MUSIC COMPANY

428 West Eighth Ave.,
Vancouver, B. C.

COLUMBIA RECORDS OF CANADA

(Manufacturer)
1121 Leslie Street,
Don Mills 5, Ontario (447-3311)

COLUMBIA RECORDS DIST. CANADA LTD.

1113 Leslie St.,
Don Mills 5, Ontario (444-6651)
Labels: Columbia, Epic, Harmony, Barclay,
Musicor, Okeh

COLUMBIA RECORDS DISTRIBUTORS

CANADA LTD.
5680 Pare Street,
Montreal 9, Quebec (RE 1 3958)

VAN HORNE ELECTRIC SUPPLY CO.

550 Crombie Street,
Vancouver, B. C. (MU 4 3321)

CANADIAN ELECTRONICS LTD.

10552-A-114th St.,
Edmonton, Alta.

THE COMPO CO., LTD. (Manufacturer)

2377 Remembrance Street,
Lachine, Quebec (637 2561)
Labels: Decca Div., Decca, Coral, Brunswick,
Vocalion, Caedmon.
Apex Div., Carnival, Challenge, Colpix, Cres-
cendo, Diamond, Everest, Lero, Point, Reprise,
Soma, United Artists, Valiant, Warner Bros.

APEX RECORDS

76 Colville Road,
Toronto, Ontario (207 4725)

ACKLANDS LTD.

216 12th Ave., S. W.
Calgary, Alta. (AM 2 9197)

(Continued on page 110)

COLUMBIA RECORDS OF CANADA, LTD.

1121 Leslie St., Don Mills 5, Ont. Canada Telephone: HICKORY 7-3311

Manufacturers & Distributors of

COLUMBIA, EPIC, OKEH, HARMONY
BARCLAY LABELS—LICENSEE OF MUSICOR



COLUMBIA RECORDS DISTRIBUTORS
CANADA, LTD.

1113 Leslie St., Don Mills 5, Ontario

COLUMBIA RECORDS DISTRIBUTORS
CANADA LTD.

5680 Pare St., Montreal 9, Quebec

VAN HORNE ELECTRIC SUPPLY CO.

550 Cambie St., Vancouver, British Columbia

CANADIAN ELECTRONICS LTD.

10552-A 114th St., Edmonton, Alberta

WE SPECIALIZE IN PREMIUM RECORDS

ATTENTION

RECORD DEALERS, RACK JOBBERS
and JUKE BOX OPERATORS

If you want the best in
music service order
directly from

LAVAL RECORDS, LTD.

649 BEAUMONT ST.
MONTREAL, CANADA

The most progressive one-stop
in Canada Today!

ALL LABELS—FREE TITLE STRIPS

Contact: Tony Choma or Dave Grief



ALSO DISTRIBUTING AND MANUFACTURING
MELBOURNE • BANFF
CELTIC • CITADEL • MUTUAL
CAPRICE • CAMPUS • EUROPA

For strong representation of your record line, Look to **RODEO RECORDS** in Canada. We are seeking diversified International material which is suited for release to the Cosmopolitan Canadian markets and We are prepared to give Top Notch representation to those lines we handle.

SOME OF OUR TOP CANADIAN ARTISTS APPEARING IN THE UNITED STATES Include

- ★ BOB KING ★ CAROL ISAAC ★ THE GEMTONES
- ★ THE ROCKATONES ★ JILLIAN HARRIS ★ VIC MULLEN
- ★ OMAR BLONDAHL ★ THE MAR-VELS, Etc.

FOR DISTRIBUTION OF YOUR LINE IN CANADA CONTACT:

RODEO RECORDS, LTD.

American Office
JAMES N. PARKS
852 Elm Street
Manchester, New Hampshire 03101
Tel. 603-623-9749

Canadian Office
GEORGE TAYLOR
4824 Cote Des Neiges Road
Montreal 26, P.Q. Canada
Tel. 514-731-0889

MUSIC CANADA

Canada's First
Music Industry Building

Home of:

The BIGLAND AGENCY

Booking:

Little Caesar and the Consuls
The Big Town Boys
Jon & Lee and the Checkmates
J.B. and the Playboys
Dee and the Yeomen
Little Diane and the Starlights
The DuKane Sextet
The Sikusis
Ritchie Knight & the Midnights
The Staccattos
Shirley Matthews
The Regents and Dunc & Judy
The Silhouette Revue
Jayson King
"The Friendly Giant
in the Bigland"

R.P.M. MUSIC WEEKLY

Canada's Only
Music Industry Weekly
Stay informed on Canada's
growing Music Industry

stan klees
productions
Canada's Top
Record Producers
BIGLAND MUSIC
COLONIAL WALT MUSIC
MUSICART & DESIGN

AND
MANY MANY
OTHERS

1940 Yonge Street
Toronto 7, Canada
Telephone (416) 487-3466

CANADA—Record Manufacturers

(Continued from page 109)

LONDON RECORDS OF CANADA LTD.

3166 Lake City Way,
Burnaby 2, B.C. (CY 8 6471)

MONTICANA RECORDS

P. O. Box 323,
Montreal 3, Quebec

PHONODISC LTD. (Manufacturer)

355 King Street, West,
Toronto, Ont. (366 8744)
Labels: Audio Fidelity, Congress, Four Corners, Chess, Checker, Argo, Joy, Kapp, King, Old Town, Tamla-Motown, Regency, Delta, Phonodisque, Stereo-Fi.

PHONODISC LTD.

Eastern Division,
4640 Decarie Blvd.,
Montreal, Quebec (482 3060)

PHONODISC LTD.

Mid West Division,
30 Carlton Street,
Winnipeg, Man. (943 9503)

ALBERTA: CENTRAL RECORD CO.

3631 Blackburn Rd.,
Calgary, Alta. (243 2586)

B. C. PACIFIC ELECTRONICS LTD.

1641 West 2nd Ave.,
Vancouver, B. C. (RE 1 8131)

QUALITY RECORDS LTD., (Manufacturer)

380 Birchmount Road,
Scarborough, Ontario (OX 8 5511)
Labels: MGM, Dot, Jubilee, Vee-Jay, Quality, Reo, Barry, 20th Fox, Deutsche Grammophon, Hickory and Red Bird. Selected other American independent labels are distributed by Quality Records on Reo, Barry and Quality labels in Canada.

TAYLOR PEARSON AND CARSON LTD.

1100 Venables Street,
Vancouver 2, B. C.

TAYLOR PEARSON AND CARSON LTD.

4340-4th Street, S. E.,
P. O. Box 70,
Calgary, Alta.

QUALITY RECORDS LTD.

Mid West Sales Division,
4th Floor Galt Bldg.,
Winnipeg, Man.

QUALITY RECORDS LTD.

Ontario Sales Division,
130 Mack Ave.,
Toronto, Ontario

QUALITY RECORDS LTD.

Quebec Sales Division,
2215 Beaconsfield Ave.,
Room 4,
Montreal 28, Quebec

CANADIAN ASSEMBLIES,

Station Street,
Amherst, N. S.

RALEIGH RECORD SALES (Red Leaf) (Manufacturer)

74 York Street,
Toronto, Ontario

TRANS CANADA RECORDS INC.,

189 Rockand Rd.,
Montreal, Quebec

LAUREL RECORD DISTRIBUTORS,

P.O. Box 1021,
Winnipeg, Man.

ARAGON ENTERPRISES LTD.,

2166 West 4th Ave.,
Vancouver, B.C.

RCA VICTOR CO., LTD., (Manufacturer)

Labels: RCA Victor (complete range) Disneyland—Prima Magnagroove
1001 Lenoir Street,
Montreal 30, Quebec

RCA VICTOR CO., LTD.,

2876 Rupert Street,
Vancouver, B.C. (604-433-6881)

RCA VICTOR CO., LTD.,

4120—6th. Street, S. E.,
Calgary, Alta. (403-243-4661)

RCA VICTOR CO., LTD.,

1450 Castlefield Ave.,
Toronto, Ont. (416-762-7311)

RCA VICTOR CO., LTD.,

5575 Royalmount,
Montreal, Quebec (514-731-3411)

RCA VICTOR CO., LTD.,

3611 Commission Street,
Halifax, N.S. (902-455-7247)
Labels (rodeo): Banff, Campus, Caprice, Celtic, Europa, Melbourne, Rodeo—International, Citadez, Mutual

RCA VICTOR CO., LTD.,

2070 Notre Dame Street,
Winnipeg, Man. 204-772-0481)

RODEO RECORDS LTD., (Manufacturer)

4824 Cote Des Neiges Rd.,
Montreal 26, Que. (514-731-0889)

SPARTAN OF CANADA,

Box 2125,
London, Ontario
Labels: ABC, Paramount, Command, Contemporary, Eurotone, Good Time Jazz, Grand Award, HiFi, Impulse, Starday, Westminster, Oriole (England), Festival Australia)

SPARTAN OF CANADA,

P.O. Box 100,
Mt. Royal Station,
Montreal, Quebec

SPARTAN OF CANADA,

57 Ingram Drive,
Toronto, Ontario
B. A. ROBINSON CO., LTD.,
167 Sherbrooks Street,
Winnipeg 1, Manitoba

WHOLESALE APPLIANCES LTD.,

8401 Fraser,
Vancouver, B.C.

TRANS CANADA RECORD INC.,

189 Rockland Rd.,
Montreal, Quebec (731-8571)
Labels: Franco, Metro, Mode, Trans Canada, Vogue, Arc

TRANS CANADA RECORD INC.,

35 Ricelieu,
Quebec City, Quebec (524-1294)

ACKLANDS LTD.

10304-108th Street,
Edmonton, Alta. (429 1311)

JOHNSTON APPLIANCES LTD.

5239 Victoria Drive, Vancouver, B.C.
(FA 5 3261)

THOMAS RATHWELL LTD.

575 Roseberry Street,
Winnipeg, Manitoba (SP 4 4561)

WALDALE LTD.

P. O. Box 339,
Amherst, N. S. (667 3308)

LONDON RECORDS OF CANADA LTD. (Manufacturer)

190 Graveline Street,
St. Laurent, Quebec (631 2061)
Labels: London, American London Group, Telefunken, Das Alte Werk, Argo, L'Oiseau Lyre, Philips, Mercury, Smash, Fontana, Wing, Limelight, Cumberland, Blue Rock, Liberty, Imperial, Dolton, Atlantic, Atco, Stax, Volt, Brook-Lyn, Focus, Hi, Monument, Duke, Peacock, Era, Rodeo, Banff, Celtic, Melbourne, Europa, Mobile Fidelity, Spoken Arts, La Voix De L'Auteur, Phillies, Rheims, Jupiter, Sound Stage 7, Rusticana, Click, Sun, France-Canada, Sur Demande, Marion, Aragon, Jamie, Guyden, Mirrosonic, Coliseum, Caprice, Copains, Bel Air, Paris, Venus, Olympia, Dial, Gaiety, Figaro, Gaudan, Mutual, Etiquette, Dore, Rampart, Citadel, Backbeat.

LONDON RECORDS OF CANADA LTD.

180 Graveline Street,
St. Laurent, Quebec (631 2061)

LONDON RECORDS OF CANADA LTD.

100 Richmond Street East,
Toronto, Ontario (EM 6 5841)

LONDON RECORDS OF CANADA LTD.

654 King Edward Street,
Winnipeg, Man. (722 4305)

LONDON RECORDS OF CANADA LTD.

628-11th Ave., S.W.
Calgary, Alta. (263 8085)

THE TOP HITS OF '65 IN CANADA

(Continued from page 108)

Un Baiser De Toi
Un Soir De Pluie
Walk Don't Run '64
What's New Pussycat
Wishin' And Hopin'
Wonderful World
Woolly Bully

Where Did Our Love Go
Where Love Has Gone
Ya Ya
You've Lost That Lovin' Feelin'

Robert Demontigny
Les Million-Airs
The Ventures
Tom Jones
Dusty Springfield
Herman's Hermits
Sam The Sham & The Pharrohs
The Supremes
Jack Jones
Joel Denis
Righteous Bros.

Trans Canada
London
Dolton
Parrot
Philips
MGM
MGM
Motown
KAPP
DC
Philles

ACROSS CANADA



MANUFACTURED AND
DISTRIBUTED NATIONALLY BY

CAPITOL RECORDS OF CANADA, LTD.

635 QUEEN ST. E., TORONTO, ONTARIO

ALSO DISTRIBUTORS OF PARLOPHONE RECORDS, ODEON RECORDS, WORLD-PACIFIC, PACIFIC JAZZ, AND OTHERS—DUOTONE NEEDLES AND ACCESSORIES

RECORD CARRYING CASES

TORONTO • MONTREAL • WINNIPEG
SASKATOON • EDMONTON • VANCOUVER

FRENCH

CANADA'S
LARGEST

DISTRIBUTOR

"LA MAISON

DU

PALMARES"



189 Rockland rd.

Town of Mount Royal

Montreal 16

Phone: 731-8571

Branch:

25 Richelieu, Quebec

Phone: 524-1294

WORLD WIDE MUSIC TRADE DIRECTORY

(Continued from page 104)

EMPRESA TÉCNICA DE EQUIPAMENTOS ELÉCTRICOS, S.A.R.L.—Apartado 2531—LISBON
(Rua Rodrigo da Fonseca, 103 r/c Sup.—Lisbon)
Phone: 68 60 72
Cable: TELETRA LISBON
Pres.: Eng. Adriano Carlos Torres Carneiro Vaz Pinto
Labels (domestic): RCA Camden, RCA Victor
Labels (others): Warner Bros.

PHILIPS PORTUGUESA, S.A.R.L.—Apartado 1088—LISBON
(Rua de Joaquim António de Aguiar, 66—Lisbon)
Phone: 68 31 21
Cable: PHILAMP LISBON
Pres.: Mr. Carel Teseling
Labels (domestic): Fontana, Philips, Polydor
Labels (others): Archiv-Produktion, Audio Fidelity, Bambino, Brunswick, Caravel, Contemporary, Coral, Critere, Cynus, Deutsche Grammophon, Edibi, Fontana/Debut, Fontana/Pacific Jazz, Fontana/Scepter, Heliodor, Jolly, King Universal, Mercury, Music, Pergola, Riverside, Roulette, Sinter, Stella

RADIO TRIUNFO, LDA (Fabrica Portuguesa de Discos)—309 Praça do Município—PORTO
Phone: 21445, 33624, 32462
Cable: RATRIL PORTO
Pres.: Mr. José Varzim, Mr. Rogério Leal
Labels (domestic): Alvorada, Melodia
Labels (others): Atlantic, Barclay, Bel Air, Belter, Carisch, Carioca, CBS, C.G.D., Copacabana, Disneyland, Ducretet-Thomson, Erato, Festival, Hickory, Hispavox, Président, United Artists, Véga.

VALENTIM DE CARVALHO, LDA—P.O. Box 2149—LISBON
(Rua Nova do Almada 97—Lisbon)
Phone: 36 70 51
Cable: TIM LISBON
Pres.: Mr. Rui Valentim de Carvalho
Labels (domestic): A Voz do Dono, Columbia, Decca, Parlophone, Pathé
Labels (others): Ace of Clubs, Capitol, Discophiles Français, Dot, His Master's Voice, Liberty, London, London/Globe, M.G.M., L'Oiseau-Lyre, Regal-Zono, Stateside, Verve

PRESSING PLANTS

ARNALDO TRINDADE & CIA., LDA—Caixa Postal 139—PORTO
(Rua de Santa Catarina 117—Porto)
Phone: 21232, 29513, 29514
Cable: RADILECTRA PORTO
Pres.: Mr. Arnaldo Trindade

CASA FIGUEIREDO—Rua de Santo António 74—PORTO
Phone: 21293
Pres.: Mr. José A. G. de Figueiredo

FABRICA PORTUGUESA DE DISCOS DA RADIO TRIUNFO, LDA—309 Praça do Município—PORTO
Phone: 21445, 33624, 32462
Cable: RATRIL PORTO
Pres.: Mr. José Varzim, Mr. Rogério Leal

VALENTIM DE CARVALHO, LDA—Caixa Postal 2149—LISBON
(Rua Nova do Almada 97—Lisbon)
Phone: 36 70 51
Cable: TIM LISBON
Pres.: Mr. Rui Valentim De Carvalho

QATAR

RECORD MFRS

AHMAD ALUTHMAN & BROS—P.O. Box 218—DOHA (Al-Jasra Square—Doha)
Phone: 3507, 3508
Cable: ALUTHMAN QATAR
Pres.: Mr. Ahmad Aluthman
Labels (others): Ace of Clubs, Ace of Hearts, Argo, Bellona, Brunswick, Cairophon, Capitol, Columbia, Command, Coral, Decca, Durium, Fontana, His Master's Voice, London, Mercury, M.G.M., Parlophone, Philips, Polydor, RCA Victor, Soutelphan, Stateside, Top Rank, United Artists, Verve, Vogue, Warner Bros., etc.

RHODESIA (South)

RECORD MFRS

ELECTRICAL, RADIO & MUSICAL INDUSTRIES LTD.—P.O. Box 1449—BULAWAYO
(Corner London & Bristol Roads—Belmont—Bulawayo)

Phone: 62627, 62670
Cable: AERIAL BULAWAYO
Mgr.: Mr. L. L. Mendelsohn
Labels (others): Angel, Capitol, Columbia, Encore, His Master's Voice, Liberty, M.G.M., Parlophone, RCA Victor, Reprise, Stateside, Teal, Warner Bros.

MUSICAL DISTRIBUTORS (PRIVATE) LTD.—P.O. Box 155—BULAWAYO
(6, Eight Avenue—Bulawayo)
Phone: 3759, 62327
Cable: GALLOTONE BULAWAYO
Pres.: Mr. Eric Gallo
Labels (domestic): Gallotone, New Sound, USA.
Labels (others): Brunswick, Decca, Deutsche Grammophon, London, Polydor.

RUMANIA

EXPORT & IMPORT

CARTIMEX STATE COMPANY FOR FOREIGN TRADE—P.O. Box 134-135—BUCHAREST
(Aristide Briand 14-18—Bucharest)
Phone: 15.49.03
Cable: CARTIMEX BUCHAREST
Pres.: Mr. Ionescu Gheorghe
Only organization to be contacted in questions of export or import of ready-made cultural goods (records and sheet music editions).

CANADA—The Past 12 Months

(Continued from page 107)

Wish That I Could Fall In Love Today." Arc continues its red hot singles sales pace with "As Many As These," by Catherine McKinnon and "Little Liar" by Terry Black coming on like runaway best sellers. Malka And Joso win many new fans as Capitol lifts a much played item from their recent album, "Ay Cosita Linda," class Canadian talent this. Harold Pounds is doing big business with his great new Canadian outing on Sparton, "Hum Drum" by Deryk And Ed. Tim (Lord Timothy) Hudson exits Montreal's CKGM for a new spot in California, San Diego to be specific. Former 'GM men, Doug Burrows and Dick Varney, relocate in Halifax and Plattsburgh, N.Y. respectively. Some action noted on an instrumental single formerly out on Capitol's Pathe line, "La Playa" by Claude Ciari. Frank Henry reports that it is to be reserviced to the Capitol mailing list under that banner after considerable American action. "UH UH UH," the solid commercial rocker by The Canadian Squires on Apex shows chart signs in several areas. Gerry Wolf the founder of Wolff Records resigns as President of the firm to enter the publishing field, debuting assorted fan and trade publications, under the corporate title, "Three Star Publications." Patti Page finally makes it very big on practically every chart in the Country with "Hush Hush Sweet Charlotte," after many weeks of slow but steady progress. Dave Carter's young daughter, billed as Debby Lori Kaye has her first Columbia release, "Pickin' Up My Hat" on the market, action with the Canadian deejays is considerable. Bob Martin ties up a sensational new record act for Columbia, The Liverpool Set. They will appear at the label's Miami

sales meet. Harold Winslow announces that Quality's Canadian Talent development award is to go to an American station for the first time. KYNO Radio in Fresno is given the award for their pioneering south of the border on behalf of "Shakin' All Over," by Chad Allen and The Expressions. Hal Ross at Phonodisc predicts solid action on a release of "Donna" by Ritchie Valens. He gets it and then some. "My Girl Sloopy" on Red Leaf by Little Caesar and the Consuls puts in strong bid to be the hottest record of the year in so far as made-in-Canada hits are concerned. It breaks chart barrier after chart barrier right across the nation.

JUNE 1965—Bill Gilliland reports that the delightful Catherine McKinnon has been set for the Ed Sullivan TV'er in the early Fall. "Tossin' And Turnin'" by Chad Allen and The Expressions develops into the national smash—with U.S. release to follow shortly—that Reg Ayers predicted some months before. Doug Crosley debuts on RCA Victor with a great cover on "Forget Domani," an album is set for release shortly. Cosmo Filane previews a new album set he has just had recorded in Britain. Betting is that a very commercial item therein, "No Money" will be released as a single. Bob Gillies marks his return to the ranks of the recording stars with a strong commercial outing on RCA, "Summer On The Sand." Action is very encouraging. Mike Doyle exits his National Promotion Post with RCA Victor, reportedly to re-enter the radio sales game with CKGM, Montreal. Phil Najovits takes leave of Allied Record Corp., to be replaced as General Sales Manager by music biz. vet, Jack Boswell. Jerry Gordon becomes Montreal branch Manager of the Company.

MUSIC PUBLISHER

EDITURA MUZICALA A UNIUNII COMPOZITORILOR DIN R.P.R.—Str. 13 Decembrie 4-6—Raionul 16 Februarie—BUCHAREST
Phone: 14 77 10

RECORD MFRS

CASA DE DISCURI ELECTRECORD—Str. Luigi Cazavillan 14-16—BUCHAREST
Phone: 14.96.15
Pres.: Engineer Gheorghiu Nestor
Labels (domestic): Electrecord

SENEGAL

MUSIC PUBLISHERS

LA RADIO AFRICAINE—Boite Postale 2477—DAKAR
(15 Avenue Jean Jaures—Dakar)
Phone: 334.90
Cable: BERNARDOT DAKAR
Pres.: Mr. C. Bernardot

RECORD MFRS

CADICI—CONSORTIUM AFRICAINE DU DISQUE ET DU CINEMA—Boite Postale 1481—DAKAR
(49, Rue de Grammont—Dakar)
Phone: 335.50
Cable: CADICI DAKAR
Director: Mr. Roger Marfaing
Labels (domestic): Vogue-Afrique
Labels (others): Durium, Gene Norman Presents, Jazz Selection, Mode, Pop, Pye, Reprise, Sidney Becket, Swing, Vogue, Warner Bros.

LA RADIO AFRICAINE—Boite Postale 2477—DAKAR
(15 Avenue Jean-Jaures—Dakar)
Phone: 334.90
Cable: BERNARDOT DAKAR
Pres.: Mr. C. Bernardot
Labels (domestic): N'Dardisc

PRESSING PLANTS

CADICI—CONSORTIUM AFRICAINE DU DISQUES ET DU CINEMA—Boite Postale 1481—DAKAR
(49, Rue de Grammont—Dakar)
Phone: 335.50
Cable: CADICI DAKAR
Pres.: Mr. Roger Marfaing

SOUTH AFRICA

COLLECTING SOCIETIES

SARRAL—SUID-AFRIKAANSE OPNAMEREGTE VERENIGING BEPERK (South African Recording Rights Association Ltd.)—P.O. Box 4301—JOHANNESBURG
(Silver House—139 Commissioner Street—Johannesburg)
Phone: 23.8757, 23.8758
Cable: DAER JOHANNESBURG
Pres.: Mr. E. C. Blatt, Mr. A. Delmont
Mechanical Licenses

SAFCA—SOUTH AFRICAN SOCIETY OF COMPOSERS, AUTHORS AND MUSIC PUBLISHERS, LTD.—P.O. Box 9292—JOHANNESBURG
(1209, Cavendish Chambers—Jeppe Street—Johannesburg)
Phone: 23-4025
Cable: ACISUM JOHANNESBURG
Pres.: Mr. Gideon Roos
Performing Rights Society

MUSIC PUBLISHERS

ARDMORE & BEECHWOOD (S.A.) (PTY.) LTD.—P.O. Box 11254—JOHANNESBURG
(32 Steele Street—Steeledale—Johannesburg—Transvaal)
Phone: 869-2661
Cable: ABEEMUSIC JOHANNESBURG
Pres.: Mr. W. F. Fraser

ARWIN MUSIC OF SOUTH AFRICA (PTY.) LTD.—P.O. Box 6216—JOHANNESBURG
(161, President Street—Johannesburg)
Phone: 23.2111
Cable: GALLOTONE JOHANNESBURG
Pres.: Mr. Martin Melcher, Mr. W. F. Lyons, Mr. A. Delmont, Mr. Ralph Trehwala

BANDSTAND (PTY.) LTD.—P.O. Box 10217—JOHANNESBURG
(21A Plein Street—Johannesburg)
Phone: 23.7169
Cable: BANDSTAND POSTBOX 10217 JOHANNESBURG
Pres.: Mr. Mervyn F. John

BELINDA (JOHANNESBURG) (PTY.) LTD.—304/5 His Majesty's Building—Eloff Street—JOHANNESBURG
—Transvaal
Phone: 834-8208
Cable: BELINDSONG JOHANNESBURG
Gen. Mgr.: Mr. Roy Walter

(Continued on page 115)

ROBERT J. STONE ASSOCIATES



post office box 703 / oshawa / canada
area code 416, 723-9404



ed
**Key to
FAST,
EFFICIENT
COAST TO
COAST
DISTRIBUTION**



QUALITY RECORDS LIMITED
380 BIRCHMOUNT ROAD,
TORONTO, ONTARIO CANADA
Phone OX-8-5511

U.S. OFFICE
130 WEST 57TH ST.
NEW YORK, NEW YORK
C/O MARSHALL,
VIGODA & BOMSER
Phone JU-2-1122

MEXICO—The Past 12 Months

AUGUST

Gene Krupa was in México with Charlie Ventura. . . . RCA technicians flew to Mérida Yucatán to record "La Troba Yucateca." . . . Los Hermanos Sandoval debuted in Los Angeles. . . . Direct from Europe, young Mexican idol César Costa arrived. . . . CBS released one of the top hits during 1964 with Argentinian Leo Dan singing "Como Te Extraño Mi Amor." . . . Chucho Monge, well known Mexican composer died at the age of 54. . . . In an emergency trip, Enrique Guzmán returned from Europe to be operated on immediately. . . . Theodore Bikel opened at "El Patio." . . . Ken Smith, Jr. signed with RCA. . . . The first LP record by Gigliola Cinquetti was released by Gamma Records. . . . Los Hermanos Carrión flew to Argentina to fulfill their first contract in that country. . . . DUSA Records took care of the Bel Art music catalogue. . . . J. Manuel Vidal Zapater, general director of Gamma Records, arrived in México. Lola Beltrán changed her mind and announced that she would retire from her music career. . . . "El Che" signed a contract with DUSA Records.

SEPTEMBER

Peerless Records started a big promotion of all the labels it represents. Enrique Guzmán is back at CBS, after a few weeks of being an exclusive of Spanish label, Hispa Vox. . . . Los Hermanos Carrión returned from Argentina after several successful performances. Hispa Vox president Enrique Ma. Peral was welcomed in México by Gamma manager José T. Muñoz. . . . Andy Russell was back in town. . . . Deutsche Grammophon executive Claus R. Petermann was in México. . . . CBS released its first LP in México with Argentinian singer Leo Dan. . . . Chico O'Farrill and his orchestra left for Colombia to do a jazz concert. . . . The fourth volume recorded by the Beatles was released by Musart. . . . Angélica María flew to Panamá to sing and do a picture. On Sept. 22 the Sixth National Jazz Festival began with the assistance of our best jazzmen (including) Tino Contreras, Freddy Guzmán, Fred Tattman, Chucho Zarzosa, Luis Ocadiz, Juan Ravelo, Victor Ruiz Pazos, the Constanza Hool jazz ballet and many other popular figures. . . . Italian singer Edoardo Vianello appeared in México. . . . Orfeon changed its record factory. . . . The Blue Bell Girls came to México for the second time. . . . Cuco Sánchez flew to New York and San Antonio. . . . Mexican musician Juan García Esquivel returned to México after an eight year absence. . . . Argentinian Mario Clavel visited us.

OCTOBER

"Broadcasting Week" started with the assistance of all the radio broadcasters in the country. . . . Constantin T. Metaxas, president of Dusa Records Associated went to Lima, Perú, to the DGG-Philips convention. . . . Victor Gutierrez Urquiza, A&R supervisor of classic music in the CBS record department, died after working there for 17 years. . . . Arturo Valdés, advertising manager of RCA, resigned his job and joined the Corporación Nacional Electrónica company. . . . Mariano Rivera Conde and Rubén Fuentes, RCA A&R men were recording in Italy. . . . Manuel Villareal, CBS Latin American coordinator came back to México from a trip to Europe. . . . DUSA Records started a big promotion campaign. . . . Edoardo Vianello recorded an album in Spanish. . . . Deutsche Grammophon executive Helmut Haertel arrived in México. . . . World known Mexican composer Agustín Lara was in again from Spain. . . . Juan García Esquivel left México for Las Vegas. . . . Emilio Pericoli signed a contract with "El Patio." . . . The Zavalas Brothers were performing in Japan. . . . Mexican group Los Loud Jets changed their name in the U.S. to the Mexican Beans. . . . Daniel Riolobos moved

from RCA to Musart. On Oct. 23, Pat Boone debuted in México. . . . Perez Prado was back organizing a Mexican band. . . . César Costa was performing in Ecuador. . . . Cumbia rhythm became popular in México. . . . The same thing happened with the coffee houses where artists of the "new wave" are performing. . . . Juan Calderon was named the new RCA promotion manager. . . . Gamma Records signed for the distribution in México of Command Records. . . . Alejandro Algara returned from Japan. . . . La Rondalla Tapatía had wonderful sales through RCA.

NOVEMBER

Marco Antonio Muñoz flew to Puerto Rico where he is a real idol. . . . César Costa did the same thing but in the direction of Argentina. . . . Enrique Guzmán returned from his second trip to Spain. . . . A new LP sung by Guzmán was released at CBS. . . . Pat Boone performed on Mexican TV. . . . RCA released a new series with albums of three records containing the best of each of its most popular artists of all times. . . . Spanish singer Salomé made her debut at "Terrazza Cassino." . . . CBS artist Carmen Rivero and her combo had wonderful sales with cumbia rhythm arrangements. . . . Carlo Angelotti (14 years old) was in town direct from Italy. . . . After more than a year's absence, world known Mexican singer Tito Guízar returned to México. . . . After a short season in Argentina, César Costa returned. . . . From Germany, Dr. Ernst von Siemens, president of the Siemens organization which owns Deutsche Grammophon, returned. . . . RCA president Bernard T. Ness flew to Lima, Perú. . . . CBS created the "Disco Club CBS, S.A." with Luis Bastón as general manager. . . . Italian record man Giuseppe Giannini arrived in México, and was welcomed by J. T. Muñoz.

DECEMBER

Patachou was greeted by the Terrazza Cassino owner at the airport. . . . The same happened with Roger Smith who is already performing at El Patio. Santo and Johnny also were in México, performing at "La Fuente" and in the theater. . . . Lawyer Walter Hoffer and publisher Enrique Levensinger were in town projecting new plans with Mexican publisher Mario Friedberg. . . . Xavier Cugat and his show left to perform in Japan. . . . To promote Mexican RCA records in the U.S., Jack Burgess and Lee Shapiro, executives of RCA in that country, came to México. And that's all. Merry Christmas to all of you.

JANUARY

Orfeon Records announces a series of new contracts with veteran artists who used to belong to other record companies. Among them are Ana María González, Amparo Montes, El Bronco Venegas, Lupe Mejía and Teté Cuevas. . . . Gamma Records released Spanish lark Marisol's "Me Conformo," which later became a hit. . . . Perez Prado was promoting his new rhythm "Dengue." . . . Puerto Rican artist Sonia Noemí was performing in México. . . . Salvador Suárez sold, in record merchandise, more than two million dollars in the past twelve months. . . . Singer and composer Cuco Sánchez signed with Mumusa Publisher. . . . César Costa was performing in San Salvador. . . . Spanish composer Augusto Algueró and his wife, actress Carmen Sevilla, arrived in México to perform at the Terrazza Cassino. . . . Pat Boone recorded a series of songs in Spanish. . . . "And I Love Her" hit number one on the hit parade. Manuel Villareal was named vice-president of Columbia Records in charge of Latin American operations. . . . Salomé signed a contract with Musart Records. . . . Italian singer Tony Dalli debuted on TV. . . . Rosita Gómez became exclusive of Peerless Records. . . . El Patio night club closed be-

(Continued on page 114)



First in artists, hits and quality

The leading label in Latin America
with a wide catalog

Pan Americana de Discos, S. A.
Apartado 17503, Tacuba, D. F.—MEXICO

ORFEON VIDEOVOX, S. A.

AV. UNIVERSIDAD 1273

PHONE 24-25-00

Cable: DIMSA

MEXICO CITY

CUSTOM SERVICE: _____

At Low rates

RECORDING STUDIO: _____

The biggest in Latinoamerica
Mastering, Plating, Color
descomposition laboratory
Pressing, Cover records
manufacturers.

MANUFACTURERS OF: _____

ORFEON, DIMSA, MAYA
and ARIEL records.

REPRESENTATIVES IN MEXICO OF: _____

WESTMINSTER, ALHAMBRA,
COLUMBIA (ESPANOLA), SOM-
MERSET, WHITE HALL, KING
RECORDS (JAPAN).



THE MOST POPULAR ARTISTS



RCA Victor Mexicana, S. A. de C.V.

Comands:

Mexico's most modern recording studios

Mexico's largest record pressing plant

Mexico's biggest record distributor

Mexico's record sales leader

Mexico's and Latin America's most
Talented and promising artists.

 **RCA VICTOR** 

RCA VICTOR MEXICANA, S. A. DE C. V.

AV. CUITLAHUAC No. 2519 MEXICO, D. F.

MEXICO—The Past 12 Months

(Continued from page 112)

cause of serious economical difficulties. Trini López debuted at the end of the month at Terrazza Cassino with tremendous success. . . . Sex goddess Brigitte Bardot is in México filming "Viva María."

FEBRUARY

Enrique Guzmán left town to perform in Argentina. . . . On Feb. 9 American actor-singer Bob Conrad debuted at Terrazza Cassino. . . . Also in Argentina were Mexican song and dance duo Los Yorsys. . . . Back to his town came Javier Vega, who signed contract with Musart Records. . . . RCA started its own TV show. . . . CBS signed a contract with folk stylist Magda Franco. . . . In México was publisher Oliver Berliner. . . . Before leaving town, Trini López made two video tapes to promote his recordings. . . . Mexican jazz pianist Mario Patrón arrived in his native country after three years of performing in Europe and Africa. . . . María de Lourdes cut the movie theme "The Night Of The Iguana" at Orfeon Records. . . . Barnard T. Ness, president of RCA Victor and Mariano Rivera Conde, vice president of the same company, flew to Los Angeles on a business trip. . . . Los Hermanos Castro signed contract with RCA. . . . Lucho Gatica is doing new recordings at Musart Records. On Feb. 20, the popular night club, Terrazza Cassino, closed its doors. . . . Young singer Alberto Vázquez performed at the Hollywood Palladium. . . . Lucha Villa did the same thing in New York.

MARCH

Andy Russell returned to México after his annual South American tour. . . . The Modern Jazz Quartet is performing at the Palace of Fine Arts. . . . Herman Díaz came to Méxi-

co to check the Latin American RCA catalogue. . . . Cuban singer José Antonio Méndez returned to México to perform at Cardini's Place. . . . RCA created a new instrumental group, La Comparsa Universitaria, which later became very popular in several countries of the world. . . . Orfeon Records signed a two and half year contract with American actor Bob Conrad. . . . Mexican singer Fabricio flew to Argentina to settle in that country. . . . Chilean singer Antonio Prieto is back in town to record an LP at RCA. . . . José T. Muñoz was promoted to general director of Gamma Records. . . . Manuel Vidal Zapater became president of the same company and Enrique María Peral, vice president. From March 21 to 26 an RCA international convention took place in México City. . . . Musart Records released, for the first time in México, commercial music tapes. . . . A new Santo and Johnny LP was released at Gamma. Paco de la Bertera, one of the RCA A&R men, left town on a business trip to New York. . . . Mexican singer Miguel Aceves Mejía extended his stand at the Puerto Rico Theater in New York for two more weeks.

APRIL

Monna Bell remains at Gamma Records for three more years. . . . From Apr. 13 to 17 a Mexican jazz festival took place at Acapulco. On Apr. 20, Andy Russell debuted at the Sahara in Las Vegas. Los 11 Hermanos Zavala received an invitation to perform on the Ed Sullivan Show. . . . German artists Freddy and Bert Kaempfert arrived in México City. . . . Marco Antonio Muñoz flew to Spain. . . . Sonia, part of the Sonia and Miriam duo, became a soloist of the RCA roster. . . . Alberto Vázquez cut his fifth LP at Musart. . . . Enrique

Guzmán returned to México after performing in several South American countries. . . . CBS announced a new LP recorded by Argentinian singer Leo Dan. . . . Santo and Johnny were back in town performing at "La Fuente." . . . La Sonora Santanera was touring in several cities of the U.S. . . . South American singer Nadia Milton was in México City. A few weeks later she signed a contract with DUSA. . . . Guillermo González Camarena, founder of television's channel 5 and inventor of a color TV system, died in an automobile accident. . . . RCA signed a distribution contract with the Atlantic label. . . . Under a new administration, the Terrazza Cassino re-opened. . . . Future smash hit "Juego de Palabras" was recorded at Peerless by Olivia Molina. . . . Guillermo Macedo, executive of Orfeon Records, flew to Venezuela to discuss terms of distribution with Siemens Venezolana. . . . DUSA Records announced distribution in México of Latin American catalogues Ansonia and Velvet. From California, Armando de Ilano, vice president and general manager of CBS, returned to town.

MAY

Olga Guillot debuted at The Baltimore Theater in New York. . . . Trini López was back in México but only for a vacation. . . . Mexican composer Luis Demetrio fulfilled a contract in New York. . . . RCA sales manager Guillermo Infante returned to México after two weeks at American RCA. . . . Mike Laurie, a Mexican artist, became number one in "cumbia" rhythms. . . . Angélica María left for Spain to work in that country for one year. . . . Los Hermanos

Carrión translated the American standard, "Blue Moon." . . . RCA Victor signed distribution in México with the American labels Disneyland, Vista Records and Motown. They did the same thing with Brazilian Elenco. . . . Roberto Morales was named international RCA A&R staffer. . . . Perez Prado left Orfeon to sign a contract with Japanese label "King." . . . Bob Conrad was in town again recording in Spanish at Orfeon. . . . Kurt Kinkele, general sales manager of Deutsche Grammophon, was in México planning distribution recordings with Constantin T. Metaxas, general manager of Dusa Record. . . . Monna Bell flew to Argentina. . . . Heinz Klinckwort, president of Peerless Records, returned from New York where he signed a distribution contract with World Pacific label. . . . After more than a year of absence, César Costa returned to TV in a musical show. . . . Grever Publisher announced, beside the publishing business, the representation of artists and a new national label. . . . Los Hermanos Castro performed at the Quid night club with a great success.

JUNE

Andy Russell is back in town after his Sahara performance. He will do several TV shows in town. . . . Gamma Records released "Combat" with Frank de Vol. . . . Argentinian idol Leo Dan arrived in México City to perform for four days in town and ten more days in several cities of the country. . . . Morris Ostin came to México City to change the distribution of his labels, Warner Bros. and Reprise, from Panamericana de Discos, to Gamma Records. . . . Provee (Continued on page 115)

MEXICO — RECORD MANUFACTURERS

RCA VICTOR MEXICANA, S.A. de C.V.
Av. Cuicahuac #2519.
Mexico 16, D.F.
Phone: 27-60-20
President: Bernard T. Ness
Director of Operations: Louis Couttolenc, Jr.
Manager Business Development and Industry Relations: David Crump
Sales Manager: Guillermo Infante
Promotion Manager: Juan Calderon
A&R: Mariano Rivera Conde, Ruben Fuentes and Paco de la Barrera
Foreign A&R: Roberto Morales
Labels: (Domestic) RCA Victor and RCA Camden
Labels: (Others) Dot, Atlantic, Ariola-er Eurodisc, Walt Disney and Motown-Tamla

CBS COLUMBIA DE MEXICO, S.A.
16 de Sep. #51 San Bartolo Naucalpan Edo. de Mexico
Phone: 27-62-20
General Latin American Coordinator: J. Manuel Villareal
President of CBS Mexicana: J. Manuel Villareal
Vice-President and General Manager: Armando de Llano
Vice-President: Jose R. Bustillos
Disco Club CBS, S.A.
General Manager: Luis Baston
Sales Manager: Raul Bejarano
Advertising Manager and Public Relations: Agustin Hernandez A.
Promoter: Rafael Castaneda
Foreign Promoter: Rafael A. Palafox
A&R: Felipe Valdez Leal, Edgardo Obregon, Gilberto Parra
International A&R: Salvador Arreguin
Labels: (Domestic) CBS and Okey
Labels: (Others) Columbia, Harmony, Montilla

PANAMERICANA DE DISCOS, S.A.
Av. Cuicahuac 2327
Mexico 17, D.F.
Phone: 27-00-20
President: Eduardo C. Baptista
Vice-President: Luis A. Gil
Sales Manager: Jose Luengo
Credit Manager: Estuardo Soto
Promotion Manager: Jesus Acosta
Designer: Jose Valdivia
A&R: Guillermo Acosta
Labels: (Domestic) Musart
Labels: (Others) Liberty, Music disc

PEERLESS DE MEXICO, S.A.
Laguna Mayran 232
Mexico 17, D.F.
Phone: 45-63-40
President: Heinz Klinckwort
General Manager: Leo Porias
Sales Manager and Promotions: Bruno Vogt
Assistant Manager: Alejandro Zaldivar
Advertising: Mario Juarez
A&R: Francisco Mendez and Eduardo Magallanes
Labels: (Domestic) Peerless and Eco
Labels: (Others) London, Telefunken, Richmond, Vox, Del Norte, Seeco and Falcon

DIMSIA (Discos Mexicanos, S.A.)
ORFEON VIDEO-VOX, S.A.
Av. Universidad 1273
Mexico, D.F.
Phone: 24-25-01
President: Rogerio Azcarraga
Vice-President: Alejandro Siegrist
A&R Chief: Guillermo Macedo
A&R: Velino M. Presa, Ricardo Carrión and Romulo Moran, Fidel A. Vista
Promotion: Porfirio Reyna

Labels: (Domestic) Orfeon, Maya, Dimsa and Ariel
Labels: (Others) Westminster, White Hall, Sumenset

DISCOS TIZOT, S.A. (Before: Disco Importadora, S.A.)
Av. Division del Norte 31
Mexico 12, D.F.
Phone: 43-72-41
General Manager: Mario Friedberg
A&R: Miguel A. Sarralde
Labels: (Domestic) Tizot, Advanced
Labels: (Others) Aym, Hi-Fi, Everest, Fantasy, World Pacific, Life, Pacific Jazz, GNP Crescendo, Challenge, Folkways, Monitor, Colpix, Elektra, Viking, Dick Jockey, Nilser, Contemporary, Vedette, WG, Fuentes, Bluebell, Style fono color, Ri-si, Vault, Clan celentano, Prosadis

DISCOS GAMMA, S.A.
Ejército Nacional 167
Mexico 5, D.F.
Phone: 45-81-52
President: J. Manuel Vidal
General Director: Jose T. Munoz
Production and Programming: Luis Moyano
Administrative Manager: Tomas Garcia
Labels: (Domestic) Gamma
Labels: (Others) Hispa-Vox, CGD, Warner Bros, Reprise, PVE, Chess-Checker-Argo, United Artists, ABC Paramount, Imperial, Vanguard, Roulette, Canadian American, Ducrette Tompson, Music Hall, Festival, Metronome, MK, Supraphon, Erato, Vogue, Zafiro, Command

DISCOS UNIVERSALES, S.A.
Rio Tiber 58
Mexico 5, D.F.
Phone: 14-34-72
General Manager: Constantin T. Metaxas
Coordinator Manager: Fritz Hentschel
A&R: Jose G. Cruz
Labels: DGG, Polydor, Philips, MGM, Mercury, Verve, Archivad Fontana

COMPANIA IMPORTADORA DE DISCOS, S.A.
Tenayuca 475-F
Mexico, D.F.
Phone: 24-46-79
President: Gabriel Mendoza
Labels: Decca, Coral, Audio-Mex, Brunswick

DISCOS CORO, S.A.
Bahia de Perula 80
Mexico, D.F.
Phone: 45-33-99
President: Federico Riojas
Labels: Co-Ro, Silvertone

DISCOS CISNE, S.A.
Carracci 64
Mexico 19, D.F.
General Manager: Rafael Ficachi
Labels: Cisne, Dicsa, Victoria

DISCOS CAPITOL DE MEXICO, S.A.
Ayuntamiento No. 54
Mexico 1, D.F.
General Manager: Andre Midani
Advertising Manager: Rene Flores
Sales Manager: Arturo Valdez
Administrative Manager: Miguel Angel de la Hoz
National A&R: Mario Gil
Foreign A&R: Rene Leon
Classic: Pablo Palomino
Labels: All the EMI Catalogue

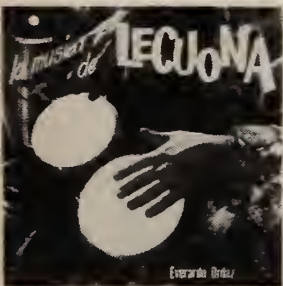

FOR THE NEW Look
In Latin Recordings
A NEW COMPLETE CATALOG.

MOST TERRITORIES STILL AVAILABLE FOR TAPE RIGHTS AND SOME FOR RECORD RIGHTS ALREADY REPRESENTED FOR RECORD RIGHTS IN THE U.S. CANADA SPAIN ECUADOR PERU CHILE URUGUAY IF INTERESTED IN YOUR TERRITORY

WRITE TO:

CoRo, S.A.

Bahía de Perula No. 80 MEXICO 17, D. F. Phone 45-33-99 45-20-65 45-34-73

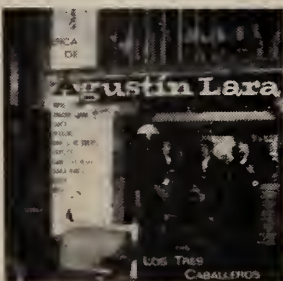
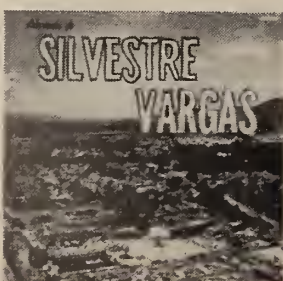

MEXICO PUBLISHERS

AMPEM — MEXICAN ASSOCIATION OF PROMOTERS AND PUBLISHERS OF MUSIC, S.C.

President: Jose Marquez
Address: Av. Chapultepec 43
Public Relations: Rogelio Brambila

(ALPHABETICAL ORDER)

BRAMBILA (BRAMBILA MUSICAL MEXICO, S.A.)

President: Rogelio Brambila P.
Address: Av. Cuicahuac 2305
Mexico, D.F.
Phone: 27-66-67
Affiliated to:
USA: Ardmore & Beechwood, Morris Music, Moonlight Music, Central Songs, Walt Disney and Zodiac Music
Argentina, Chile and Uruguay: Julio Korn
Colombia: Ecomus
Ecuador: Sadram and Mel. Ecuatorianas, S.A.
Brasil: Irmaos Vitale y Euterpe
Venezuela: Evmi
Spain: Canciones del Mundo, Hispavox, Gromofono Odeon
Germany: Edition Accord, Edition Montana
France: Pathe Marconi, Eddie Barclay
Italy: Voce del Padrone, Curei
England: Ardmore and Beechwood, Good Music
Japan: Toshiba Music Publishing, Star Edition
Australia: Castle Music Publishing, Star Edition

CAMPEI (CORPORACION ARTISTICA MUSICAL, PRODUCCIONES Y EDICIONES INTERNACIONALES)

General Manager: Javier Ochoa Valle
Av. Insurgentes Sur 85-3er piso
Mexico, D.F.
Phone: 43-71-40
General Manager: Javier Ochoa Valle
Artistic Representations: Alfredo Marcelo Gil, (Gil and Gil)
Professional Dept.: Alfredo Gil Jr.
President: Alfredo Gil
General Director: Leodegario Hernandez Campos
Consolidated Music Publishers Inc.
Music Publishers Holding Corp.
Mills Music, Inc.
Japan: Kusano Music, Inc. and Shinko Music Publishing Co.
Larry Shayne Music Inc.
Music Samous Corp.
Sam Fox Publishers Co. Inc.

COMPAS—EDICIONES COMPAS, S.A.

Av. Insurgentes Sur 300-Condominio
Mexico, D.F.
General Manager: Jesus Martinez Ross

EMMI (EDICIONES MEXICANA DE MUSICA INTERNACIONAL, S.A.)

Manager: Mario Alvarez
Address: Dr. Valenzuela 10
Mexico, D.F. P.O. Box 1465
Phone: 21-03-31
Assistant Manager: Mario de Jesus
Affiliated to:
USA: Southern Music Publishing Co., Inc. Peer International Corporation
Argentina: Editorial Argentina de Musica Internacional, S. de R.L. (EDAMI)
Brasil: Editora de Musica Brasileira e Internacional, S.A. (EMBI)
Chile: Southern Music International
Colombia: Peer de Colombia, Ltda
Dominican Republic: Peer International Dominicana
Ecuador: Emporio Musical, S.A.

Puerto Rico: Peer International Corp. de Puerto Rico
Venezuela: Peer International de Venezuela
France: Societe D'Editions Musicales Internationales (S.E.M.I.)
Germany: Peer Musikverlag G.m.b.H.
England: Southern Music Publishing Company Ltd.
Italy: Edizione Southern Music S.R.L.
Spain: Editorial Musical Ibero Americana, S.A.

GREVER (GREVER INTERNACIONAL, S.A.)

Address: Londres 179
Mexico, D.F.
General Manager: Teodoro a Dehesa

MARQUEZ (HNOS. MARQUEZ, S.A.)

Address: Av. Chapultepec 43.
Mexico, D.F.
Phone: 12-02-28
Managers: Jose and Ramon Marquez

MUNDO MUSICAL (EDITORIA MUNDO MUSICAL, S.A.)

Address: Puebla 286-3er piso
Mexico 7, D.F.
Phone: 25-10-42
General Manager: Jose Vaca Flores

PHAM (PROMOTORA HISPANO MEXICANA DE MUSICA, S.A.)

General Manager: Luis Martinez Serrano
Address: Dr. Valenzuela 10
Mexico, D.F.
P.O. Box 542
Phone: 21-79-45

MEXI-MUSIC, S.A.

Address: Av. Division del Norte 31
Mexico, D.F.
General Manager: Mario Freidberg
Affiliated to:
Gene Autry Four Stars Sales Co. U.S.A.
Golden West Melodies Inc. U.S.A.
Jat Music Inc. U.S.A.
Weiss and Barry U.S.A.
Western Music Publishing Co. U.S.A.
Taj Music, Co. U.S.A.
Dick Yames Music Limited and Associated Companies (England)
Seven Seas Publishing Co. Pty. Ltd. (New Zealand)

FERMATA MEXICANA, S.A.

Address: Av. Division del Norte 31
Mexico, D.F.
General Manager: Mario Freidberg
Representants:
Ediciones Internacionales Fermata (Argentina S.R.L.)
Editora e Importadora Musical Fermata Brasil Ltda.)
Commander Publications (U.S.A.)
Editorial Star S.R.L. (Italy)
Editoriale Clan S.R.L. (Italy)
Edizione Leonardi S.R.L. (Italy)
Charles Brull Ltd. (England)
Keith Bros. Music Publishing Co. Ltd. (England)
The Peter Maurice Music Co. Ltd. (England)

EDITORIAL TEOCALI, S.A.

Address: Av. Division del Norte 31
Mexico, D.F.
General Manager: Mario Freidberg
Woomera Music Pty. Ltd. (Australia)
Almo Music Corp. (U.S.A.)
Irving Music Corp. (U.S.A.)

WORLD WIDE MUSIC TRADE DIRECTORY

(Continued from page 111)

CARSTENS-DE WAAL PUBLICATIONS—P.O. Box 9973
—JOHANNESBURG—Transvaal
(605/606 Bradford House—116 President Street—Johannesburg)
Phone: 22.8146
Pres.: Mr. Anton De Wool

DEE JAY MUSIC CO.—P.O. Box 7186—JOHANNESBURG—Transvaal
(605/606 Bradford House—116 President Street—Johannesburg)
Phone: 22.8146
Pres.: Mr. Louis Combrinck

GOOD MUSIC AFRICA (PTY.) LTD.—P.O. Box 6216
—JOHANNESBURG
(161, President Street—Johannesburg)
Phone: 23.2111
Cable: GALLOTONE JOHANNESBURG
Pres.: Mr. Felix Faecq, Mr. A. Delmont, Mr. John Rose

IMPALA MUSIC CO.—P.O. Box 9973—JOHANNESBURG—Transvaal
(Bradford House—116 President Street—Johannesburg)
Phone: 22.8146
Pres.: Mr. Anton De Wool

LAETREC MUSIC LTD.—304/5 His Majesty's Building
—Eloff Street—JOHANNESBURG
Phone: 834.8208
Cable: BELINDSONG JOHANNESBURG
Pres.: Mr. A. G. J. McGroth

MELODY MUSIC (PTY.) LTD.—P.O. Box 9299—JOHANNESBURG—Transvaal
(32, Bosman Road—Ophirton—Johannesburg)
Phone: 33.9317
Director: Mr. David G. Fine

MELOTOONGOLWE MUSIEKUITGEWERS
MELOTONE WAVES MUSIC PUBLISHERS—P.O. Box 11070—JOHANNESBURG—Transvaal
(42, Mitchell Street—Berea—Johannesburg)
Phone: 44.9412
Pres.: Mr. Olaf Andresen

MUSIC PUBLISHING CO. OF AFRICA (PTY.) LTD.—P.O. Box 6216—JOHANNESBURG
(161, President Street—Johannesburg)
Phone: 23.2111
Cable: MUSIPUB JOHANNESBURG
Director: Mr. Ralph Trehwela

PLANETARY-NOM AFRICA (PTY.) LTD.—P.O. Box 6216—JOHANNESBURG
(161 President Street—Johannesburg)
Phone: 23.2111
Cable: GALLOTONE JOHANNESBURG
Pres.: Mr. Morris Levy, Mr. Morris Gurlek

PLYMOUTH MUSIC (PTY.) LTD.—304/5 His Majesty's Building—Eloff Street—JOHANNESBURG
Phone: 834.8208
Cable: BELINDSONG JOHANNESBURG
Pres.: Mr. Ray Walter

SOUTHERN MUSIC PUBLISHING CO. (S.A.) (PTY.) LTD.—P.O. Box 10274—JOHANNESBURG—Transvaal
(225, Jepp Street—Johannesburg)
Phone: 23.6222
Cable: SOUTHMUSIC JOHANNESBURG
Gen. Mgr.: Mr. G. Taylor

SUN-PACIFIC MUSIC—P.O. Box 17004—JOHANNESBURG
(608 Hunstanton-Twist Street—Hillbrow—Johannesburg)
Phone: 724.8278
Cable: REKLAMA JOHANNESBURG
Pres.: Mr. Gilbert Gibson

RECORD MFERS

E.M.I. (SOUTH AFRICA) (PTY.) LTD.—P.O. Box 11254—JOHANNESBURG—Transvaal
(32 Steele Street—Steeledale—Johannesburg)
Phone: 869.2661
Cable: SOUNDBOX JOHANNESBURG
Pres.: Mr. W. J. Richmond
Labels (domestic): Columbia, His Master's Voice, Parlophone
Labels (others): Capitol, Liberty, M.G.M., Odeon, Stateside, Warner Bros.

GALLO (AFRICA) LTD.—P.O. Box 6216—JOHANNESBURG—Transvaal
(161, President Street—Johannesburg)
Phone: 23.2111
Cable: GALLOTONE JOHANNESBURG
Pres.: Mr. Eric Gallo
Labels (domestic): Continental, Gallotone
Labels (others): ABC-Paramount, Archiv-Produktion, Atlantic, Audio Fidelity, Brunswick, Cameo, Coral, Decca, Deutsche Grammophon, Durium, Heliodor, Hickory, Murray Banks, Parkway, Polydor, Somerset, Telefunken, Vox, etc.

GRAMOPHONE RECORD CO., LTD.—P.O. Box 2445
—JOHANNESBURG—Transvaal
(cor. Fox and Gold Streets—Johannesburg)
Phone: 23.0546
Cable: AFRICORD JOHANNESBURG
Pres.: Mr. Arnold Golemba
Labels (domestic): Kiddie Sound, Tropik, Unika
Labels (others): Caedmon, CBS, Mercury, Philips, Riverside

METEOR RECORDS (PTY.) LTD.—P.O. Box 6640—JOHANNESBURG—Transvaal
(187, President Street—Johannesburg)
Phone: 22-6403, 22-8851
Cable: METEORDISC JOHANNESBURG
Pres.: Mr. R. R. Moskovitz
Labels (domestic): Big Beat, Big Eight, Jazz, Kristal, Meteor, Saffir
Labels (others): Ad-Lib, Condid, CGD, Embossy, Hispavox, Lenox, Musidisc, Oriole, Prima-Magnagroove.

SUN-PACIFIC MUSIC—P.O. Box 17004—Hillbrow—Johannesburg
(608 Hunstanton—cor. Twist & Kotze Streets—Hillbrow—Johannesburg)

Phone: 724.8278, 724.8279
Cable: REKLAMA JOHANNESBURG
Pres.: Mr. Gilbert Gibson, Mr. Taffy Kikillus
Labels (domestic): Sun-Pacific, Unika

TEAL RECORD CO., LTD.—P.O. Box 4105—JOHANNESBURG—Transvaal
(124, President Street—Johannesburg)
Phone: 22-0355
Cable: TEALREC JOHANNESBURG
Pres.: Mr. A. G. J. McGrath
Labels (domestic): Drum, Teal
Labels (others): Delyse, Golden, PPX, RCA Comden, RCA Victor, RCA Victrola, Reprise.

TELSTAR RECORDS (PTY.) LTD.—304/5 His Majesty's Building—Eloff Street—JOHANNESBURG
Phone: 834.8208
Cable: BELINDSONG JOHANNESBURG
Pres.: Mr. Ray Walter
Labels (domestic): Roy, Telstar

TROUBADOR RECORDS (PTY.) LTD.—P.O. Box 1225
—JOHANNESBURG—Transvaal
(1-5, Browning Street—Woluter—Johannesburg)
Phone: 24-1787, 24-9157, 24-9158
Cable: TROUBADOR JOHANNESBURG
Joint Mon. Dir.: Mr. M. Fagin & Mr. I. Katz
Labels (domestic): Church, FM, Goza, Goll, Hit, Manzini, Troubadour
Various foreign franchises pressed under the Troubadour label.

TRUTONE (PTY.) LTD.—P.O. Box 9299—JOHANNESBURG—Transvaal
(32, Bosman Road—Ophirton—Johannesburg)
Phone: 33-9314
Cable: TRUTONE JOHANNESBURG
Man. Dir.: Mr. D. G. Fine
Labels (domestic): Envee, Juweel, Perel, Pret, Quality, Rave, Renown, Ridge, Winner
Labels (others): Command, Doi, Palette, Roulette, Somerset, United Artists, Verve, Vox, Westminster

PRESSING PLANTS

AUDIO INDUSTRIES (PTY.) LTD.—P.O. Box 6640—JOHANNESBURG
(109, Smit Street—Johannesburg)
Phone: 724-4847
Cable: METEORDISC JOHANNESBURG
Pres.: Mr. P. J. Lombard

SUDAN

RECORD MFERS

ELECTROHOUSE—P.O. Box 823—KHARTOUM
(Parliament Avenue—Syrian Club Building—Khartoum)
Phone: 77027
Cable: ELEKTROHAUS KHARTOUM
Proprietor: Mr. O. Toniellian
Labels (others): Angel, Archiv-Produktion, Barclay, Bel Air, Brunswick, Capitol, Columbia, Decca, Deutsche Grammophon, Durium, Encore, Fontana, Heliodor, His Master's Voice, London, Mellophone, Mercury, M.G.M., Odeon, L'Oiseau-Lyre, Parlophone, Philips, Polydor, RCA Victor, Telefunken, Vogue, Warner Bros.

SWITZERLAND

COLLECTING SOCIETIES

IMPACT, S.A.—P.O. Box 34—Cassarate—LUGANO
(Via delle Scuole 10—Cassarate—Lugano)
Phone: 32093
Cable: IMPACT LUGANO
Directors: Mr. Ron Kass, Mr. Alan Bates
SUISA—SOCIETE SUISSE DES AUTEURS ET EDITEURS
—General Guisan-Quai 38—ZURICH 2/27
Phone: 25 77 00
Cable: SUISA ZURICH
Pres.: Dr. Ulrich Uchtenhagen
Mechanical Licenses and Performing Rights Society

EUROPEAN HEAD OFFICE

INTERDISC, S.A.—P.O. Box 448—LUGANO
Phone: 32093
Cable: INTERDISC LUGANO
Directors: Mr. Alan Bates, Mr. Ron Kass
European representatives for: Battle Records, Jazzland Records, Pacific Jazz, Riverside, Vee Jay Records, World Pacific. Listed labels distributed by Philips/Fantana in most countries.

RCA OVERSEAS S.A.—P.O. Box 127—GENEVA 1
(14, rue Mont Blanc—Geneva)
Phone: 32.51.25
Cable: RADIOINTER GENEVA
Vice-Pres. & Mon. Dir.: Peter F. Baumberger

MUSIC PUBLISHERS

EDIFO S.A.—Postfach 377—ZÜRICH 4/40
(Badenerstrasse 332—Zürich 4/40)
Phone: 54 64 77
Cable: EDIFO ZURICH
Director: Mr. M. A. Rosengarten

EDITION HELBLING—Hous Melodie—VOLKETSWIL-ZÜRICH
Phone: 86 43 93
Cable: HELBLINGMUSIC ZURICH
Pres.: Mr. Albert Brunner

EDITION CROZ LUZERN—Postfach 530—Lucerne 2
(Seidenhofstrasse 14—Lucerne)
Phone: 3.43.25
Pres.: Mr. Paul Cron

EDITIONS DE BELMONT S.A.—Avenue des Alpes 70
—MONTREUX
Phone: 62 45 55
Pres.: Mr. Jean-Jacques Finsterwald

EDITIONS SIDEM S.A.—8, rue de Hesse—GENEVA
Phone: 25.59.55
Cable: SIDEM GENEVA
Pres.: Mr. Heinz Liechli

MONDIAMUSIC S.a.r.l.—8 rue de Hesse—GENEVA
Phone: 25.59.55
Cable: MONDIAMUSIC GENEVA
Pres.: Mr. Heinz Liechli

(Continued on page 118)

MEXICO—The Past 12 Months

(Continued from page 114)

dora de Discos, S.A. signed a new distribution contract with American label Kapp. . . . Record distributor Herman D. Gimbel, bought Audio Fidelity Records from Sidney Frey. Among the new plans were to increase national catalogue. . . . La Comparsa Universitaria recorded its second LP at RCA. . . . Lena y Lola returned from their Central American tour. . . . Enrique Guzmán filmed a picture in Ecuador. . . . "SKA" rhythm was introduced in México by Los Yorsys. . . . Discos Capitol de México, S.A. is the name of the EMI organization in Mexico. This company, under the direction of Andre Midani, distributes all the EMI catalogue and at the same time produces Mexican recordings with new artists. . . . Harvey Schein, general manager of Columbia Records, arrived in México, welcomed by CBS vice president and general manager Armando de Llano. . . . Rogelio Azcárraga, president of Orfeon Record, flew to New York to do business with Peer International Publishing, of which Mexican pubberies Pham and Emmi are a part. Rogelio Azcárraga bought this Mexican subsid. . . . Agustin Lara, famous Mexican composer, signed a contract with Orfeon Records. . . . Los Hermanos Castro released "Yo Sin Ti" at RCA. . . . After seven years of absence in their country, the famous female trio Las Hermanas Montoya returned. . . . Alberto Vázquez left town for a seven week

tour through several Latin American countries.

JULY

Problems between musicians and recording companies began, and all the record companies stopped recording. . . . Mexican comedian Sergio Corona left México to do a tour through Europe and South America, to last till the end of the year. . . . Arturo Valdés was named sales manager of Discos Capitol de México, S.A. (EMI). . . . René León took charge of the international department and Mario Gil was named to the A&R section of this new company in México. . . . Miguel Aceves Mejia left for Argentina and other South American countries. He is still the most popular Mexican artist in Latin America. . . . American actor Poncie Ponce was in México performing at the Terraza Cassino. . . . A new Mexican label appeared in México; its name is Tip. . . . José T. Muñoz announced the distribution by Gamma Records of the English company Pye by Gamma Records. . . . Rogelio Villareal was named general coordinator of the Polydor and Philips catalogues. . . . Peerless Records started its annual promotion. . . . Guillermo Buerckle, who used to be sales manager of Dusa Records, left his job and probably will sign a contract with Cisne Records. . . . Antonio Aguilar and his wife, a singer and actress Flor Silvestre, returned to México after more than a year of touring Latin American countries.

... IN SPAIN



Columbia
represents

DECCA

LONDON

durium

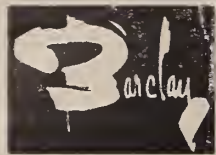

Alhambra

We also have an extensive catalog of Spanish music—

Address: **FABRICA DE DISCOS COLUMBIA**
LIBERTAD 24, MADRID, SPAIN
FACTORY IN SAN SEBASTIAN (SPAIN)

SPAIN

The Past Twelve Months

During the past year the Spanish record market has grown up enough for us to say that now we are approaching the European level. For the first time in the Spanish record industry some records have reached the 100.00 mark. That is the case of "La Yenka," the Finnish dance imported by Johnny and Charley (Charley died this year in a car accident) and "Flamenco" by The Brincos. But, what is more important is the tremendous amount of new records released every month (here in Spain the list of new records covers almost everything from the rest of the world and also Spanish production, and almost every record has a good sale. Much better than last year and incredible if you compare it with the figure of only two years ago. But the possibilities of the market are even bigger and there are more record fans every day. Many record players (at low prices) is the basis of the miracle, together with the big promotion given by radio, the musical shows of TV and the press. All of these factors will now be discussed.

There are now as many radio receivers as people in Spain. Transistors are the same story. There are about 400 stations which cover every place in Spain. And many of these stations have musical programs with the latest records released in the country. Obviously, radio helps everyday to create record buyers.

Spanish TV now has two channels (VHF and UHF), has a new group of musical programmes. The two big shows are "Sabado 65" produced in Madrid and "Noche de estrellas," produced in Barcelona. The first every Saturday and the second one every Monday. Besides these big shows (an hour and a half) there are four others of half an hour presented by famous deejays Raúl Matas, Pepe Palau and another show produced by Bill Caram. The audience of TV covers every area of Spain and has been evaluated at ten million spectators.

The press has begun to be interested in records. Almost every magazine (weekly) has its own record section. Newspapers have record sections once a week. And there are five magazines which specialize in records. These are "Discobolo," "Fonorama," "Fans," "Correo de la Radio" and "Prensa Musical Internacional."

That conditions of the information mediums are simultaneous to the noted increase of the economic level in the nation. Now we can say that the record era has begun in Spain. That is the opinion of the eight established labels.

We can note this year for the first time an increase of the interest in modern Spanish music. We have now a lot of young groups which are not only recording good international tunes in Spanish but continuously creating new tunes, more or less originals. The attempts for the Spanish sound are quite successful in different ways. Some groups are very representative of the trend. Instrumental groups such as Los Relampagos Los Sonor and Los Flaps has been successful not only in Spain but abroad as well. Los Sirex and Los Brincos are the most well-known vocal instrumental groups. The last one had the biggest hit on the modern music scene, "Flamenco," and they've also recorded it in Italy. The sound is a mixture of Spanish flavor with an international beat. On the other hand, you have such groups as Los Pekenikes, that record, beside international hits, their own compositions or old traditional Spanish themes in the beat of today. Micky y Los Tonys, Los Mustang, Lone Star, Los Catinos, Los Continentals, Los 4 Jets, Los Shakers are also very well known groups.

On the side of vocalists, several new young people are coming up with fresh sounds. Those singers, who usually sing international hits in Spanish are now looking for modern Spanish music because the international hits are now sung in Spanish by their own creators. This is the case with the

Surfs, Steve Lawrence, Connie Francis, Cliff Richard, Mina, Tony Dallara, Rita Pavone, Alain Barriere, etc.

The Spanish music is now on the move. Some artists have gone to record in other countries or they've had their tapes sent. Labels have begun to promote their productions abroad. Esteba Garcia Morencos, from Zafiro, has recently been in Italy for this purpose and José Ramón Batalla from Belter recently went to South America with the same purpose. Alfonso, from Belter, toured a great deal this year in order to promote Spanish music.

Publishers are now considering that they can do a good business with Spanish music and are capturing young talents. A year ago, the publishing business was limited to representation of foreign catalogues and the presentation of some Spanish items in the festivals.

The growth of the Spanish music biz has been made possible by the tremendous increase of the advertising and promotion done by the record productions and, if there is something good in them, they become hits.

The most successful artists are those ones who get recordings in other languages: Raphael, Luis Gardéy (he recorded recently in Italian), the Brincos. Among others we find the Duo Dinámico. These two boys were the first case of a success with modern Spanish music six years ago with sales of 25,000 copies of records of their own compositions. It seemed that they have fallen, but now they have a new hit with a Spanish flavor, "Esos Ojitos Negros." They have also recorded some of their best songs in English and Italian and are bound to do the same in French.

It is impossible to list here the names of all the artists who are now not here. So they will be named in the Spanish columns which will run in the future, telling the most important news concerning these artists.

The increase of sales figures is wide-spread. Companies report rises from 20% to 40% over last year. The most spectacular advance is RCA. The label's sales of the first quarter of 1965 were 60% ahead of the same period last year. EMI reports a total increase of 35%. The firm's managing director, George Alexander, told us that the turnover of the company has doubled in the last four years. EMI's satisfactory year in Spain has been due to a large extent to strong repertoire, both national and international. Alexander also told us that there has been a general decline in demand for American recordings, due to the infrequency appearances of American artists in Spain compared with European artists.

That point is very interesting because this year we have received visits from the most important European artists: Aznavour, Barriere, Rita Pavone, Françoise Hardy, Petula Clark, Sylvie Vartan, the Animals, Gianni Morandi, Mina, Dallara, Nico Fidenco, Richard Anthony, the Moody Blues, etc. But no American artists of importance came to Spain for personal appearances or TV.

At the beginning of July, The Beatles came to Spain for two first-time personal appearances. They were quite successful. The press said they really liked "El Cordobés," the famous bullfighter with long hair, because they sang in the bullrings where "El Cordobés" received the frenetic applause of the masses.

Resuming our run-down, the panorama is now clear. There are big hopes for the future because of the increase of the economic level and the growth of the promotion. Consequently, the interest of people in records is bigger than ever. At the moment there is no limit to the record industry boom. We predicted this in our column two years ago.



los brincos
the biggest
musical
event
of this year



Luis
Gardéy



Salome

Spanish golden
record 1964



Marisol

- flamenco & Classical Guitar
- the big hits in Modern music
- folklore music of Spain

ZAFIRO, THE SPANISH LABEL AROUND THE WORLD

Campomanes, 10 MADRID - SPAIN

NoVoLa



SPAIN—Best Sellers by Labels

BELTER

TITLE	ARTIST	LABEL
E.P.'s		
Ay Qué Lluève	Manolo Escobar	
Ciudad Solitaria (Lonely Town in Spanish)	Mina	
Sapore Di Sale (In Spanish)	Tony Dallara	
Quiero	Lola Flores Y Antonio Gonzalez	
América	Los 5 Latinos	
Y Volvamos Al Amor	Los T.N.T.	
What I'd Say	Ray Charles	
Qué Suerte	Ennio Sangiusto	
Como Se Quiere A Los Hijos	Paquito Jerez	
El Valiente Cordobés	El Mejorano	

L.P.'s		
Manolo Escobar		
Franz Joham Presenta Mis Amigos Del Lunes		
Lola Flores Y Antonio Gonzalez		
The Ray Charles Story (Volumes I, II and III)		
Memorias Antologicas Del Cante Flamenco (Volume I, II, III and IV)		
Sanremo 1964		
Desfile De Famosos		
The Modern Jazz Quartet And Orchestra		
Mina		
Nina & Frederick		

COLUMBIA

E.P.'s		
Ay Mi Perro	Nino De Antequera	Columbia
La Mamma	Charles Aznavour	Barclay
Et Pourtant	Charles Aznavour	Barclay
Zapateado De Sarasate	Antonio	Columbia
La Leyenda Del Beso	Ataulfo Argenta conducting	Columbia
Route 66	The Rolling Stones	Decca
La Virgen De Guadalupe		Columbia
La Luna Y El Toro	Marife De Triana	Columbia
Te He De Querer Mientras Viva	Marife De Triana	Columbia
Maria De La O	Marife De Triana	Columbia

L.P.'s		
Concierto De Aranjuez	Narciso Yepes	Columbia
La Verbena De La Paloma	Ataulfo Argenta conducting	Columbia
Los Gavilanes	Ataulfo Argenta	Columbia
Bailemos De Nuevo	Edmundo Ross	Decca
Obertura 1812 Tchaikowsky		Decca
Machucambos		Decca
Beethoven, 9 Sinfonia	Ernest Anserment	Decca
Bach, Toccata Y Fuga	Robert Sharples	Decca
La Revoltosa	Ataulfo Argenta	Columbia
La Dolorosa—Los Calveles	Ataulfo Argenta	Columbia

FONOGRAM

E.P.'s		
Poupée De Cire, Poupée De Son	France Gall	Philips
Los Paraguas De Cherburgo Original Soundtrack		Philips
La Chica Del Trébol	Rocio Durcal	Philips
Venecia Sin Ti	Jorge	Philips
Oh Mi Señor	Miguel Rios	Philips
El Amor	Jaime Morey	Philips
Le Penitencier	Johnny Hallyday	Philips
El Cordobés	Gonzalo Gonzalez	Philips
Charada	Los Sonor	Philips
Sapore Di Sale	Los 3 De Castilla	Philips

L.P.'s		
Misa Criolla-Misa Luba		Philips
Siete Novias Para Siete Hermanos (Original Soundtrack)		MGM
Connie Francis In Spanish		MGM
Los Claudios		Polydor
Pasodobles De Banda Hispanica		Philips
Siempre The Platters		Mercury
Dos Guitarras En Estereo	Paco De Lucia Y Ricardo	Philips
Ronda	Modrego	Philips
Viva Cugat	Las Tunas	Philips
Juerga Flamenca	Xavier Cugat	Mercury
	Various Artista	Philips

ODEON (EMI)

E.P.'s		
I Should Have Known Better	Beatles	Odeon
Fanny	Luis Aguile	Odeon
Ciudad Solitaria	Luis Aguile	Odeon
Twist And Shout	Beatles	Odeon
Mi Vida	Los Mustang	Voz Su Amo HMV
She Loves You	Beatles	Odeon
Tell Me Why	Beatles	Odeon
Please Please Me	Beatles	Odeon
Lo Espanol	Duo Dinamico	Voz Su Amo
Ce Monde	Richard Anthony	Voz Su Amo
The House Of Rising Sun	The Animals	Voz Su Amo
A Present Tu Peux T'en Aller	Richard Anthony	Voz Su Amo

L.P.'s		
Hard Day's Night	Beatles	Odeon
Hits By The Beatles		
Recital De Exitos No. 3	Various Artists	Voz Su Amo
Casse Noisette (Tchaikowsky)	Royal Philharmonic Orch.	
Dancing With The Shadows		Voz Su Amo
Scherezade (Rimsky Korsakov)	Royal Philharmonic Orch.	
La Parranda-Los Calveles	Various Zarzuela Artists	
Music In Color	Frank Pourcel	Voz Su Amo
New World Symphony (Dvorak)	Orch. of the N.W. German Radio	

RCA ESPAÑOLA

E.P.'s		
Borracho	Luis De Lucena	
Cuore	Rita Pavone	
Sapore Di Sale	Gino Paoli	
Si Canto	Sylvie Vartan	
Ma Vie	Alain Barriere	
La Mas Bellas Del Baile	Sylvie Vartan	
No Soy Digno De Ti	Gianni Morandi	
Viva Las Vegas	Elvis Presley	
Hoy De Rodillas	Gianni Morandi	
Que Me Importa Del Mundo	Rita Pavone	
Contigo En La Playa	Nico Fidenco	

L.P.'s		
La Tuna Pasa	Tuna De La Facultad De Veterinaria	
Vuelva Carlos Gardel		
Lo Mejor De Jorge Negrete		
Siempre La Tuna	Tuna De Madrid	
Exitos RCA	Various Artists	
Rita Pavone		
Recuerdo De Jorge Negrete		
El Divino Impaciente	Jose Maria Peman	
Recuerdos De Mario Lanza		
Beethoven, 6 Sinfonia	Orq. Filarmonica De Viene	

VERGARA

E.P.'s		
Ma Vie	Los Catinos	
Que Te Deje De Querer	Los Sirex	

Goldfinger	Jose Guardiola	
Se Piangi Se Ridi	Bobby Solo	Ricordi
Amore Scusami	John Foster	
Ho Capito Che Ti Amo	Emilio Pericoli	Ricordi
Humor Catala	Joan Capri	
Hello Dolly	Louis Armstrong	Kapp
Downtown	Francisco Heredero	
Cae La Nieve	Lita Torello	

L.P.'s		
Opera Sacra	Pablo Casals	
Duos De Opera	Monsterrat Cabale y Bernabe Marti	Kapp
Hits Invierno		
Louis Armstrong Hello Dolly		
Sinfonia Patetica (Tchaikowsky)	Orq. Sinfonica Radio de Colonia	Arida
Oberturas De Wagner		
Al Caiola (Besame Mucho, Ritual Fire Dance...)		Time
Jose Guardiola		
Cole Porter		
Adriano Celentano		

HISPAVOX

E.P.'s		
La Yenka	Johnny and Charley	Hispavox
Tu Seras Mi Baby	Les Surfs	Festival
No Tengo Edad	Gigliola Cinquetti	CGD
Si Tuvieras Un Martillo	Trini Lopez	Reprise
Y Volvamos Al Amor	Marie Laforet	Festival
St. Tropez Twist	Peppino Di Capri	International
Los Cuatro Muleros	Los Pekenikes	Hispavox
La Bamba	Trini Lopez	Reprise
Mi Vida	Raphael	Hispavox
Las Palmeras	Alberto Cortez	Mooglow

33 LP		
Katuska	Sorozabal	Hispavox
La Del Manojito De Rosas	Sorozabal	Hispavox
Tabernera Del Puerto	Sorozabal	Hispavox
Los Gavilanes	Guerrero	Hispavox
Luisa Fernanda	Torrola	Hispavox
Antologia Del Cante Flamenco	Varios	Hispavox
La Verbena De La Paloma	Chapi	Hispavox
Lo Mejor Del Ano!	Varios	Varios
La Bamba	Trini Lopez	Reprise
Tu Seras Mi Baby	Les Surfs	Festival

ZAFIRO

E.P.'s		
Flamenco	Los Brincos	
Bailando La Pulga	Los Brincos	
Chica Ye-Ye	Rosalia	
Yo Que No Vivo Sin Ti	Luis Garday	
Recordar	Mochi	
Nit De Llampes	Los Relampagos	
Muneca De Cera	Los Pekes	
La Luna Y El Toro	Mikaela	
La Primera Vez	Elder Barber	
El Mundo	Adriangela	

L.P.'s		
Vacaciones Ye-Ye	Varios	
Canciones Espanolas	Alfredo Kraus	
La Guitarra Espanola	Marciso Yepes	
Tablao Flamenco	Varios	
Dona Francisquita	Alfredo Kraus—Ana Ma Olaria	
Viva La Tuna	Tuna de la Facultad de Derecho	
Famosos De Zarzuela	Varios	
Luisa Fernanda	Sagi-Vela—Dolores Perez	
Megation Ye-Ye	Mochi y Micky y Los Tonys	
Tangos	Carlos Acuna	

1965

VERGARA

SPAIN



LISTEN TO THE MUSIC OF SPAIN

Ask For Our Export Catalog

VERGARA S.A. General Mola 4, Barcelona (9) Spain

SPAIN MUSIC PUBLISHERS

ABERBACH (MADRID), S.A.
Carmen 20, Madrid 13

ADITORIAL ALIER
Carmen 27, Madrid 13

EDICIONES MUSAICALES LUIS ARAQUE
Ríos Rosas 28, Madrid 3

EDICIONES ARMONICO-CLIPPER'S
Rambla de Cataluña 10, Barcelona 7

EDICIONES MUSAICALES AUTORES REUNIDOS
Salud 19, Madrid 13

EDITORIAL BOILEAU
Provenza 285-287, Barcelona 9

EDICIONES MUSAICALES CALYPSO
Alcalá 70, Madrid 9

CANTAGALLO, Ediciones Musicales
Edificio Espana
Gr. 2-Pl. 7-No8

EDITORIAL CANCIONES DEL MUNDO
Carmen 20, Madrid 13

EDITORIAL CANCIONES FRANCIS-DAY
Carmen 20, Madrid 13

EDITORIAL CARCELLE
Farell 4, Barcelona 14

EDICIONES MUSAICALES CARTHO
Sagasta 23, Madrid

EDICIONES MUSAICALES CLAVE
Alcalá 70, Madrid 9

EDICIONES COLUMBIA
Montseny 12, Barcelona 12

EDICIONES CONNELLY
Rambla de Cataluña 10, Barcelona 7

EDICIONES MUSAICALES DUMOR
Montera 36, Madrid 13

EDITORIAL MUSICAL IBERO AMERICANA (E.M.I.A.)
Diputación 337, Barcelona 9

EDICIONES ESSEX ESPAÑOLA
Mayor 27, Madrid 13

EDITORIAL FANTASTICA
Cava Alta 10, Madrid 13

EDICIONES FIESTA EN TRIANA
Adriano 40, (Apartado de Correos 493), Sevilla

EDITORIAL GAZON
Tuset 15, Barcelona 6

EDICIONES GRAMOFONO-ODEON
Urgel 234, Barcelona, en Madrid, Arenal 9

EDITORIAL HARMONIA
Carrera de San Francisco 9, Madrid 5

EDICIONES HERSANT
Diputación 337, Barcelona 9

EDICIONES HISPAMERICA
Mayor 13, Madrid 13

EDICIONES HISPANIA
Av. de José Antonio 31, Madrid 13

EDICIONES MUSAICALES HISPAVOX
Cuesta de Santo Domingo 11, Madrid 13

EDICIONES INTERNACIONALES DE MUSICA MODERNA
Concordia 6, Barcelona 4

EDICIONES MUSAICALES I.F.I.
Marqués del Duero 106, Barcelona 15

EDICIONES MUSAICALES IRIS
Consejo de Ciento 193, Barcelona 11

MILLS MUSIC ESPAÑOLA
Alcalá 70, Madrid 9

EDITORIAL MOMENTO MUSICAL
Horno de la Mata 3, Madrid 13

EDICIONES MUNDO DE RITMOS
Postas 16, Madrid 12

EDICIONES MUSAICALES MADRID
Mayor 27, Madrid 13

EDICIONES MUSAICALES MUNDO MELODIE
Consejo de Ciento 193, Barcelona 11

EDITORIAL MUSICA DE ESPAÑA
General Mola 258, Madrid 16

EDITORIAL MUSICA MODERNA
Marqués de Cubas 6, Madrid 14

EDITORIAL MUSICA DEL SUR
Diputación 337, Barcelona 9

EDICIONES PINGUINOS
Muntaner 111, Barcelona 11

EDITORIAL PUERTA DEL SOL
Alcalá 70, Madrid 9

EDICIONES QUIROGA
Alcalá 70, Madrid 9

EDICIONES RCA ESPAÑOLA
Av. de América, Madrid 17

EDITORIAL RITMO Y MELODIA
Villarreal 18, Barcelona 11

EDICIONES SONOMEZ
Clarisas 21, Carabanchel Bajo, Madrid 19

EDICIONES MUSAICALES SIRIUS
Apartado 792, Barcelona

EDICIONES MUSAICALES STAR
Rosellón 408, 1º, 1ª, Barcelona 13

SPAIN RECORD COMPANIES

***BELTER S.A.**
Address: Gomis, 1 Barcelona, Spain
Labels: Ri-Fi, Salvador, Atlantic, Vox, Curci, Meazzi, Palette, Deutsche Vogue, Metro-nome, etc.

Staff:
Managing Director: D. Juan Ramon Batalla
A&R: D. Joaquin Alfonso Navas
Musical: Casas Auget
Commercial: D. Juan Fernandez
Int. Deptm.: D. Jaime Mir
Advertising: D. Carlos Ayerbe
Promotion: D. Ernesto Riveras

***DISCOPHON S.A.**
Address: Valencia 288, Barcelona, Spain
Labels: Epic, Swedisc, Artec, Italdisc, Sonet, Triola, Secco, Colpix, Everest, Supraphone, Canadian American, Apollo

Staff:
Commercial Director: D. Manuel Alavedra
Artistic Director: D. Francisco Ortega

***COMPANIA DEL GRAMOFONO ODEON S.A. (EMI)**
Address: Urgel 234, Barcelona, Spain
Labels: Voz Su Amo, Odeon, Regal, Capitol, Pathé, Stateside, Liberty, Verve, etc.

Staff:
Managing Director: Mr. George Alexander
Marketing Director: Mr. Antonio Alberich
Administrative Dir.: D. Juvenal Iglesias
A&R: Mr. Werner Raehse
Promotion: D. Jesus Jarabo
Advertising: D. Font Gasol

VERGARA S.A.
Address: Paseo General Mola 9, Barcelona, Spain
Labels: Alma, Vergara, Marbella, Kapp, Ricordi, Time, Cetra, Clan, Oriole, Ariola, Eurodisc, Ariston, Angelicum, BAM, Studio SM, CFD, Style, Vox, etc.

Staff:
Managing Director: D. Nicolas Suris
General Manager: D. Alberto Serra
Production: Arturo Mas
Musical: D. Jose Valero
Advertising: D. Ramon Morenilla
Classic Division: D. Oriol Martorell

***ZAFIRO S.A.**
Address: Campomanes 10, Madrid, Spain
Labels: Zafiro, Novola, Iberofon, Ducretet, Saar

Staff:
General Director: D. Esteban Garcia Morencos
Int. and Advertising: D. Antonio Ortega
A&R: Miss Carmen Grau
Sales: D. Jose Sagi Vela

RCA ESPAÑOLA S.A.
Address: Torre de Madrid, Planta 7, Of 8, Madrid, Spain
Labels: RCA Victor, Pye, Telefunken, Dot, Wet, GNP, etc.

Staff:
Managing Director: D. Guillermo Caram
A&R: D. Alfonso Gallego
Music Publishing: D. Antonio Martinez
Import-Export: D. Manuel Orellana
Promotion: Luis Cuesta Villanueva

***FONOGRAM S.A.**
Address: Avda. de America y Hernandez de Tejada, Madrid, Spain
Labels: Archiv, Audio Fidelity, Bambino, Brunswick, Coral, Fontana, Heliodor, MGM, Mercury, Polydor, Riverside

Staff:
General Manager: D. Julio Sampedro
A&R: D. Ricardo F. de la Torre
DGG A&R: D. Rafael Niedelliner
Classic: D. Jose Maria Quero
Advertising: D. Jesus Campos

***HISPAVOX S.A.**
Address: Cartagena 62, Madrid, Spain
Labels: Hispavox, Vogue, Vega, ABC Paramount, Warner Bros, Reprise, CGD, United Artists, Laurie, Hickory, AZ, Cameo, Parkway, CBS, etc.

Staff:
General Director: D. Jose Manuel Vidal
Commercial Director: D. Luis Vidal
International Dep: D. Luis Calvo
A&R: D. Rafael Trabuchelli

***COLUMBIA**
Address: Libertad 24, Madrid, Spain
Labels: Columbia, Alhambra, Decca, London, Barclay, etc.

Staff:
General Director: D. Antoini Inurrieta
Commercial: D. Francisco Flórez
Advertising: D. Albino Jiménez
Musical Dep: Trejada, Cisneros, Milhau, Laurent

*These companies also have pressing plants.

EDICIONES TECLADO
Andrés Borrego 5, Madrid 13

UNION MUSICAL ESPAÑOLA
Carrera de San Jeronimo 26, Madrid 14

EDITORIAL UNIVERSAL JAZZ
Chinchilla 2, Madrid 13

EDICIONES UNIVERSO
Apartado de Correos 12.308, Madrid

EDICIONES VIRGINIA
Aragon 217, Barcelona 7

WORLD MUSIC ESPAÑOLA
Diputación 337, Barcelona 9

EDICIONES MUSAICALES SYMPHONIE
Valdecanilla 26, Madrid 17

EDICIONES ROBERT MELIN IBERICA, S.A.
Barquillo 49, Madrid 4

RADIO RECORD IBERICA
Rambla de Cataluña 10, Barcelona 7

WORLD WIDE MUSIC TRADE DIRECTORY

(Continued from page 115)

MUSIKVERLAG ZUM PELIKAN—Bellerivestrasse 22—ZÜRICH 8/34
Phone: 32 57 90
Cable: PELEDITION ZURICH
Pres.: Dr. Ernst Brandenberger

MUSIKVERTRIEB A.G.—Postfach—ZÜRICH 40 (Badenerstrasse 555—Zürich 9)
Phone: 54 97 54
Cable: MUSIKVERTRIEB ZURICH
Pres.: Mr. M. A. Rosengarten

SOUTHERN MUSIC A.G.—Postfach 617—ZÜRICH (Heinrichstrasse 38—Zürich)
Phone: 42 31 38
Cable: SOUTHMUSIC ZURICH
Pres.: Mr. Albert Brunner

ELECTROMUSIC LTD.—Nauenstrasse 71—BASLE 2
Phone: 34 92 50
Cable: ELMUBA BASLE
Pres.: Mr. Fritz Voegelin
Labels (domestic): Alpha, Tell
Labels (others): Arlecchino, Baroque Records, Cetra, Discophon, Ember, Excelsius, Juke Box, Kritos, Krysta, KTB, Omega, Ossa, Polarix, Sabrina, SAEF, 777, Tempo.

FINSTERWALD & CANTACUZENE—Avenue des Alpes 70—MONTREUX
Phone: 62 45 55, 62 45 56
Cable: DISQUES MONTREUX
Pres.: Mr. I. Cantacuzene
Labels (others): Adventure, Arlequin, Belter, Cam-Curci, Carosello, Chancellor, Charlin, Circus, Centrepoint, Crescendo, Debut, Dimsa, Disc AZ, Dixieland Jubilee, Dounia, Durium, Erato, Everest, Fiori Musicali, Gazell, Gene Norman Presents, Golden Guinea, Jardin des Arts, Jazz Collector, Jazz Selection, King Jazz, Majestic, Mode, Nixa, Orfeon, Pastorale et Musique, Piccadilly, Pop, Pye, Reprise, Resonances, Roulette, Royal, Somerset, Sonet, Sprint, Storyville, Studio SM, Super-Majestic, Swing, Swing, Tempo, Tico Titamus, Tono, Triomphe du Disque Français, Typic, Unidisc, Vogue, Vogue Cochon d'Inde, Vogue Kangourou, Vogue Pingouin.

FONO-GESELLSCHAFT LUZERN—Postfach 530—LUCERNE 2 (Seidenhofstrasse 14—Lucerne)
Phone: 2.22.88
Cable: FONO LUZERN LUCERNE
Pres.: Mr. Paul Cron
Labels (domestic): Fono
Labels (others): Ecclesia, Harmonia Mundi, Politeia.

JECKLIN & CO.—Postfach—ZÜRICH 1/24 (Rämistrasse 42—Zürich 1/24)
Phone: 24 16 73, 24 39 41, 24 13 64
Cable: PIANOJECKLIN ZURICH
Pres.: Paul, Peter & Hans Jecklin
Labels (domestic): Columbia, Gloria, Odeon
Labels (others): Angel, Arco, Atlantic, Candid, Caramba, Carisch, Celson, Choir, Commodore, Compagnia Generale del Disco, Contemporary, Derby, Die Prominente Stimme, Directional Sound, Encore, Epic, Favorit, Folkways, Golden 12, Good Time Jazz, Imperial, International, Italia, Jolly, Kabarett aus Wien, Kapp, Lebendiges Wort, Metronome, Minivox, Music, Musica Mundi, Musica Sacra, Patmos, Parlophone, Pathe, Regal, Society For Forgotten Music, Stateside, Stella, Time, Unikum, Vox.

MUSIKVERTRIEB—Postfach—ZÜRICH 40 (Badenerstrasse 555—Zürich 9)
Phone: 54 97 54
Cable: MUSIKVERTRIEB ZURICH
Pres.: Mr. M. A. Rosengarten
Labels (domestic): Decca, Elite-Special
Labels (others): Ace of Clubs, Ace of Hearts, Acquario, Argo, Ariola, Artone, Athena, Barclay, Baronet, Bel Air, Cadence, Cameo/Parkway, Capitol, Cinevox, Club, Colpix, Cornet, Crown, Ducretet Thomsen, Eurodisc, Everest, Festival, Funckler, GDC, Golf Drouot, Hed Arzi, Hispavox, Jazztone, Linda, London, L'Oiseau-Lyre, RCA Camden, RCA Victor, RCA Victrola, RCA-Vik, Ricordi, Secco, 707, Rondada, Tavola, Telefunken, Telear, Tivoli, Triola, Tropical, Twist, 20th Century Fox, Vega, Warner Bros., Weekend.

SYRIAN ARAB REPUBLIC

RECORD MFRS

A. CHAHINE & FILS—Rue Sallie—Face au Parlement—DAMASCUS
Phone: 12878
Cable: ACHAHINEFILS DAMASCUS
Mgr.: Mr. Mozart Chahine
Labels (domestic): Voix de l'Orient
Labels (others): Chant du Monde, Deutsche Grammophon, Ducretet-Thomson, Liberty, Mercury, M.G.M., Odeon, Parlophone, Pathé, Philips, Polydor, Stateside, Top Rank, Vogue.

GEORGE MURR HREIKE & CO.—P.O. Box 2230—DAMASCUS (Parliament Avenue—Damascus)
Phone: 11891
Cable: GEORGE MURR HREIKE DAMASCUS
Pres.: Mr. George M. Murr
Labels (domestic): Baidaphon, Duniaphon, Metrophon, Sot El Fan, V
Labels (others): Brunswick, Capitol, Coral, Decca, London, Pye, RCA Camden, RCA Victor, Telefunken.

MAHMOOD'S RADIO SERVICE—P.O. Box 374—DAR-ES-SALAAM (Independence Avenue—Dar-Es-Salaam)
Phone: 20410
Pres.: Mr. Mahmood Kaderali
Labels (domestic): ASL, Gallotone, OK, USA.
Labels (others): Ace of Clubs, Ace of Hearts, Arge, Bellona, Brunswick, Capitol, Columbia, Coral, Decca, Ember, Encore, Fontana, His Master's Voice, Liberty, London, Mercury, M.G.M., Parlophone, Philips, Pye, RCA Camden, RCA Victor, RCA Victrola, Reprise, Ronnex, Stateside, Teony, Telefunken, Verve, Warner Bros., Waverly, etc.

THAILAND

RECORD MFRS

BAE TECK HUAT—P.O. Box 521—BANGKOK (286-288 New Road—Werngnakornkasem—Bangkok)
Phone: 21831
Cable: TECKHUAT BANGKOK
Pres.: Mr. Bae Hui Chung
Labels (domestic): Asawin, Hanumarn
Labels (others): M.G.M., and several other labels.

BLACK & WHITE CO., LTD.—P.O. Box 335—BANGKOK (708, Mahachai Road—Bangkok)
Phone: 20054
Cable: BLACKWHITE BANGKOK
Pres.: Mrs. Hia Lau Jik Eng
Labels (domestic): Columbia, NC
Labels (others): ABC-Paramount, Angel, Atlantic, Audio Fidelity, Blue Note, Capitol, Colpix, Columbia, Contemporary, Decca, Dolton, Dot, Kapp, Liberty, London, Mercury, Polydor, RCA Victor, United Artists, Verve, Warner Bros., Westminster.

CHING THAI REGD. ORD. PARTNERSHIP—669 Chakraphet Road—Burapa Palace—BANGKOK
Phone: 24471
Cable: CHINTAICOM BANGKOK
Pres.: Mr. Maitri Boondiskulchock
Labels (others): own import from abroad of among others the following labels: Cameo, Canadian-American, Parkway, Richmond, Philips, Telefunken, RCA Camden, etc., etc.

KAMOL SUKOSOL CO., LTD.—P.O. Box 178—BANGKOK (857 Mahachai Road—Bangkok)
Phone: 20270, 23215
Cable: KAMOL BANGKOK
Pres.: Mr. Kamol Sukosol
Labels (domestic): Bull, Dragon, Lucky, Mountain, Suntaraporn, Swan
Labels (others): The EMI and Decca group of records.

KIM HUAT RECORD LTD. PARTNERSHIP—250-252 Werngnakornkasem—Opposite S.A.B.—BANGKOK
Phone: 27239
Cable: KIMHUAT BANGKOK
Pres.: Mr. Liak Meng, Mr. Sae Seow
Labels (others): Own import from abroad of among others: Cadence, 49th State, Liberty, etc. etc.

T. NGEK CHUAN LTD. PARTNERSHIP—P.O. Box 405—BANGKOK (Phrasumaen Road—Banglampoo—Bangkok)
Phone: 20560
Pres.: Mr. T. Ngek Chuan Dhanvarjor
Labels (domestic): Rabbit, T Ngek Chuan, Thong Shai
Labels (others): RCA Victor, Teichiku, etc.

TOGO

RECORD MFRS

D.T.G. (SOCIETE ALLEMANDE DU TOGO) S.A.R.L.—Boite Postale 299—LOME (9, Route d'Aného—Lome)
Phone: 31-57
Cable: DETEGE LOME
Director: Mr. M. H. Plümacher
Labels (others): Brunswick, Coral, Deutsche Grammophon, Heliodor, M.G.M., Polydor, United Artists, Verve.

TRINIDAD

RECORD MFRS

COOK-CARIBBEAN LTD.—P.O. Box 659—PORT OF SPAIN (26 Sackville Street—Port of Spain)
Phone: 31290, 6655
Cable: COOK TRINIDAD
Pres.: Major J. Lamotte Kerr
Labels (domestic): Cook
Labels (others): Columbia, Ember, His Master's Voice, Odeon, Parlophone, Piccadilly Jazz, Pye.

FEDERAL MUSIC CO., LTD.—P.O. Box 517—PORT-OF-SPAIN (8, Dundonald Street—Port-of-Spain)
Phone: 52337, 7858
Pres.: Mrs. Margaret Lucky-Samaroo
Labels (domestic): Guardian, RCA Victor, Tropico
Labels (others): RCA Camden, United Artists

WEST INDIES TELECOMMUNICATIONS & ELECTRONICS LTD.—P.O. Box 890—PORT-OF-SPAIN (Cor. Gordon & Maingot Streets—Mount Hope—Port-of-Spain)
Phone: 92246, 92247
Cable: WITELCO TRINIDAD
Dir.-Mgr.: Mr. Selwyn Pollonais
Labels (domestic): Telco
Labels (others): D-L Records, Island Records

TRUCIAL STATES

RECORD MFRS

VITHALDAS V. & SONS—P.O. Box 105—DUBAI
Phone: 9444
Cable: KARANI DUBAI
Pres.: Mr. Vithaldas Valabhdas
Labels (others): Barclay, Columbia, Decca, His Master's Voice, London, M.G.M., Polydor, RCA Camden, RCA Victor, Verve, Vogue, etc.

TUNISIA

RECORD MFRS

SITELEC S.A.—26 Rue de Portugal—TUNIS
Phone: 242.860, 243.003
Cable: SITELEC TUNIS
Pres.: Mr. S. D. Abita
Labels (others): Coral, Deutsche Grammophon, Polydor
(Continued on page 126)

SCANDINAVIA—The Last 6 Months

JANUARY:

The year started with plenty of problems coming up. The record manufacturers were not satisfied with their agreement with the mechanical collecting society NCB in Copenhagen and had refused to renew the contract as of January 1st. This on the other hand made it impossible for the manufacturers to make any new recordings after that date, or to import foreign records made after that date. Denmark, Sweden and Finland was involved in the conflict with Norway to follow July 1st, unless the problem was solved before that date. . . . The musicians' strike in Norway continued, stopping union members from participating in record sessions, as well as working at certain restaurants, cafés, hotels, etc. . . . Finland had their own strike, too, the motion picture artists refused to make new films unless they got some compensation if and when the film was shown in TV. That strike two years old, finally ended in the middle of 1965. . . . Sweden saw the first Gold Disk in two or three years, it went to Sven Ingvars, Philips-recording group who managed to sell a lot more than 100,000 of the "Fröken Fräken," a local tune by Thore Skogman. . . . Swedish Parliament opened its session Jan. 12th, among many other things to discuss if to drop the special luxury tax on records (20¢ on singles and 60¢ on LPs), and later decided to do so from July 1st. The tax debuted July 1, 1948. . . . Record sale in Norway was going up, reports said, particularly LPs increased their sale very much. . . . Denmark liked "I Feel Fine" with The Beatles, so did Norway and Sweden, too, when 1965 started. In Finland, Lasse Mårtensson had a local language version of "The House of the Rising Sun" at the top of the charts. . . . STIM, Swedish Performing Rights Society suggested to the government that a special law should require licenses for tape recorders as a compensation for the loss the record industry had when thousands of people taped their favorite tunes from radio programs instead of buying a record, but nothing has been decided so far. . . . And from Finland came something called Jenka, later being known as Letkis.

February:

Norway gave a Gold Disk to late Jim Reeves, this time for 50,000 sold "I Won't Forget You," and a Silver for 25,000 sold "I Guess I'm Crazy." . . . The conflict between NCB and the record manufacturers continued and no solution was in sight until one of the last days of Feb. a bulletin said that the problem has been solved and the manufacturers can start making records again after March 1. . . . The Eurovision Song Festival in Naples in March started with local song Festivals in Scandinavia. Denmark, who a year ago said it would never join those spectacle again, changed its mind and picked a song for Naples, "For din skyld" (Because of you), Finnish audiences voted for a Jenka, but TV authorities considered this not good enough and sent a slow fox trot and got plenty of complaints from everybody, particularly after that Luxembourg had been winning with a Jenka inspired tune. Norway choiced "Karussell" and Sweden sent opera singer Ingvar Wicksell to Naples with "Annorstädes vals" which furthermore was sung in English at Naples. . . . The year long strike among musicians in Norway finally came to an end. . . . "I Feel Fine" with The Beatles was still at the top in Denmark and Norway, while Finland preferred the local "Tango Pelargonía" with Kari Kuuva and Sweden had turned to "Little Honda" with The Beach Boys.

MARCH:

Finish radio listeners voted for the most popular group, and nobody was surprised to find Beatles, Rolling Stones and Shadows in the top in the order as mentioned. . . . Spader Records debuted in Sweden, but seems to have disappeared from the market almost immediately. . . . People in the trade as well as the artists left

for Naples, Italy, and the Eurovision Song Contest. . . . Another newcomer in Swedish record biz, Midnight Sun Records, manufactured by Moonlight Music, debuts and get hits already from the start. . . . Swedish publisher Stig Anderson to New York and California to teach the Americans how to do the Jenka/Letkis. . . . March was a busy month in all Scandinavian recording studios, at least in the Danish and Swedish, the two countries most hurt by the copyright conflict that ended March 1st. . . . The first recordings from the Eurovision Song Contest at Naples began to appear at the charts in Scandinavia. . . . Denmark listened to a local Danish recording of the Swedish song "Fröken Fräken" with Johnny Reimar, Finland preferred "Tango Pelargonía," a local song and of course a tango, with Kari Kuuva, Norway preferred the original Swedish version of "Fröken Fräken" with Sven Ingvars, and Sweden, finally, got a topseller The Honeycombs on Pye with "That's The Way." The latter was picked from an LP and released as a single in Sweden and became a hit immediately.

APRIL:

Late Jim Reeves became the first in Norway to get a Diamond Disk. His "I Love You Because" had sold 76,000 in Norway with 3.6 million inhabitants. . . . Tamla/Motown label debuted at the Scandinavian market, handled by the EMI companies here. . . . Swedish music people began to "discover" United States as never before, judging from the many who went to New York for biz talks, Stig Anderson, Felix Stahl and Sture Borge Dahl among the publishers, Börje Ekberg and Anders Holmstedt among record people and in May-June, publisher Thore Ehrling. . . . Why do like everybody else, was the slogan of publisher Lennart Reuter-skiöld who packed his trunks and went to Moscow, Warsaw, Prague and other eastern European music centers. . . . Johnny Reimar topped the Danish charts for a second month with his "Lille fregnede Louise," which later gave him a Silver Disk and Finland continued a second month with "Tango Pelargonía" with Kari Kuuva. Sven Ingvars was at the top in Norway with "Fröken Fräken," also for the second month, while Beatles got a chance in Sweden with "Rock And Roll Music."

MAY:

I.F.P.I. had their council meeting in Stockholm May 17th to 20th with record people from among others Perú, Israel and South Africa attending. . . . Norwegian lark Wenche Myhre got a Silver Disk for "La meg vaere ung." . . . Dag Häggquist of Sonet spent most of the month traveling around Europe for business talks. . . . Lani and Pandorec, two new labels, debuted at the Swedish market. . . . The song "Cadillac," a top seller all over Scandinavia, seemed to be published by everybody, at least three publishers claims that it is their song. . . . Japan is the future country for record export, it was said by almost everybody here in Scandinavia who by now have had very good contacts with Japanese record industry. . . . LP sales is growing in Sweden, was the general opinion, but from Finland it was reported a very bad year, saleswise (see separate story in Finnish section). . . . Felix Stahl back from New York, starting American Songs AB, a new publishing house. . . . Bobby Bare getting Silver Disk in Norway for the sale of 25,000 of "500 Miles Away From Home." . . . Jørg-Fr. Ellertsen A/S in Norway celebrates its first and very successful anniversary at the Norwegian record market. . . . The Sonet companies in Scandinavia introduces Epic here. . . . "Poupée de Cire, Poupée de Son" with France Gall, Eurovision Song Contest winner in March, is topping the charts in Denmark, Beatles with "Rock And Roll Music" is what people want most in Finland and Norway, while The Hep Stars, a new Swedish group is the sensation in Sweden with "Cadillac" at the top

of the charts and two more records among the top 10.

JUNE:

The Renegades, a British group recording in Finland, looks like a big export possibility for the Finns. Their records are on the charts in Finland and Germany and has been released in Benelux and Japan, too. . . . Multitone AB published the song "Invisible Tears" here under a Swedish title that means "What Kind of Weather Is This?" In July, when most Swedes had their annual vacation and raining every day, the song wouldn't need much promotion to become a real hit. . . . The invasion of artists for summer tours in Sweden had started and names as Honeycombs, Kinks, France Gall, Georgie Fame, Louis Armstrong, Alma Cogan, P. J. Proby, Downliners Sect, just to mention a few entertained the Swedish audiences, and in some cases also audiences in the other Scandinavia countries. . . . Beatles and "Rock And Roll Music" was what Danish record buyers preferred, "Pikku Nina" with Kari Kuuva made the big money in Finland, Beatles again in Norway, but here with "Ticket To Ride" and finally The Hep Stars in Sweden, now with "Farmer John."

JULY:

For some strange reason, July 1 is the day when prices, taxes, etc., are

going up in Sweden. The 17 years old special luxury tax on records was dropped but another tax on practically everything sold in Sweden went up from six to around ten per cent. The publishers raised the prices on sheet music with 10¢. . . . Factories stopped and offices closed and about half the Swedish population started their annual vacation, and the annual rain period also started as usual. . . . Cupol in Sweden adds Cresendo to the other labels the company handles. . . . In Denmark an LP in the classical field outclassed all pop idols and became the number one top seller in LP market. . . . Rolling Stones gave concerts in Norway, the teenagers liked them but the newspapers said it was the most terrible they had ever seen or heard. . . . Record publishing people, unless they are away on vacation, are busy preparing the new season, supposed to start around Aug. 15th or Sept. 1st. . . . Rolling Stones was at the top of the charts in Denmark with "Heart Of Stone," Katri Helena topped the Finnish charts with the Jenka "Minnie tuuli kuljettaa," the song the Finns wanted to have sent to the Eurovision Song Contest in Naples in March, a Swedish group, The Jailbird Singers topped the Norwegian charts with "Där björkarna susa," a Swedish oldie, and Animals with "Bring It On Home To Me" was top seller in Sweden.

Publisher Of The Big Hits

Musikförlaget ESSEX AB

Regeringsgatan 45

Stockholm C

Sweden

SERVING THE INTERNATIONAL MUSIC BUSINESS

FASTEST RECORD DELIVERY THROUGHOUT THE WORLD BY AIR MAIL
COMPLETE LINE OF ALL AMERICAN LABELS

ALL NEW RELEASES

AIRDISC U.S.A.

SINGLES • ALBUMS

Every quantity shipped. Prices on request.

Box 545, Radio City Station
New York, N. Y. 10019

Payments by bank draft or International Money Order or on account.



DAY BY DAY...WEEK AFTER WEEK...YEAR AFTER YEAR... ● ● HITS FROM ALL OVER THE WORLD ON THE SCANDINAVIAN CHARTS ● ● ● ● ●

Mr Sture Borge Dahl ● Sonora Musikförlags AB
Lidingövägen 50 Fack Stockholm 27
Telephone: 635950 Telegrams: Sonora Telex: 1609

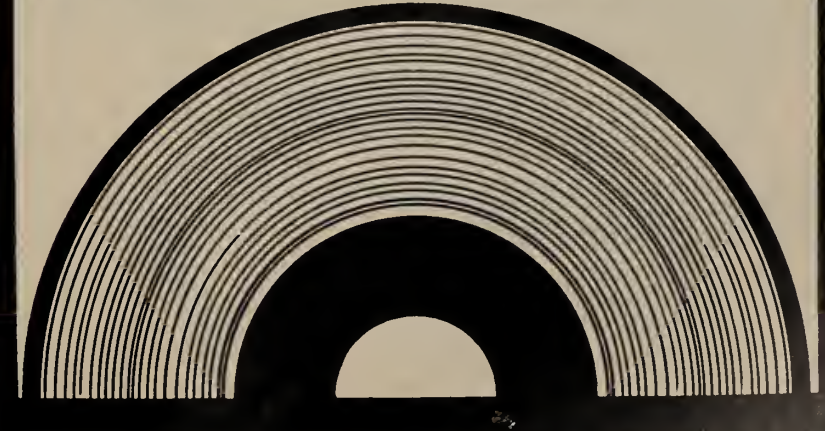



SONET

ARTISTS
with
INTERNATIONAL
SUCCESS



SUZIE

HAS SOLD ALMOST 500,000 COPIES IN GERMANY IN LESS THAN A YEAR. "Du Gehst Vorüber," "Max Und Moritz" and "Ich War Allein." Success spreading all over Europe. Labels: Germany, Austria & Switzerland: Vogue, Holland: CNR, France: Pathé Marconi, Italy: SAAR, USA: ABC-Paramount, Scandinavia & Finland: Sonet.



JERRY WILLIAMS

Scandinavia's leading r & r artist with following all over Europe. Labels: Germany: Star Club, Austria & Switzerland: Star Club and Sonet, France: Pathé Marconi, Spain: Discophon, USA: Laurie, Scandinavia & Finland: Sonet.



JAN ROHDE

started the dance craze JENKA with a string of jenkka hits in several countries. Labels: Germany: Metronome, Holland: Delta, Belgium: Show, France: Pathé Marconi, Spain: Discophon, Scandinavia, Finland, Austria & Switzerland: Sonet.



RAY ADAMS

has had many big hits in Scandinavia and was recently signed to Sonet. Soon to be introduced in Germany, Austria & Switzerland. Labels: Sweden, Denmark & Finland: Sonet, Norway: Philips, Italy: Durium.

RUNE ÖFWERMAN

Jazz pianist with commercial success. Right now getting action with his "COOL" album in the U.S.A. on the Argo label. Labels: Scandinavia & Finland: Sonet, USA & Canada: Argo.

SONET GRAMMOFON AB
Box 39062 —
Stockholm 39 Sweden

SWEDEN — Music Publishers

A. SCHROEDER MUSIKFORLAG—Brahegatan 24—STOCKHOLM O

Phone: 61 75 30
Cable: swedenmusic stockholm
President: Mr. Stig Anderson

ABR. LUNDQUIST AB—Surbrunnsgatan 30—STOCKHOLM Va

Phone: 34 55 20
President: Mr. Einar Hylin

AHLINS MUSIKFORLAG AB—Kungsholmsgatan 20—STOCKHOLM K

Phone: 51 63 86
Cable: ahlinmusik stockholm
President: Mr. Ernfrid Ahlin

AMERICAN SONGS AB—Drottninggatan 55—STOCKHOLM C

Phone: 21 69 97
Cable: stockholmsmusik stockholm
President: Mr. Felix Stahl

ANDERSSONS MUSIKFORLAG AB—Sodra Forstadsgatan 6—MALMO C

Phone: 23 659
President: Mr. Ake Andersson

BARTON (SCANDINAVIA) AB—Drottninggatan 65—STOCKHOLM C

Phone: 11 62 40
President: Mr. Ake Gerhard-Larsson

BELINDA (SCANDINAVIA) AB—Drottninggatan 65—STOCKHOLM C

Phone: 11 62 40
Cable: belindsong stockholm
President: Mr. Ake Gerhard-Larsson

BENS MUSIC AB—Brahegatan 24—STOCKHOLM O

Phone: 61 75 30
Cable: swedenmusic stockholm
President: Mr. Stig Anderson

BROADWAY MUSIC AB—Brahegatan 24—STOCKHOLM O

Phone: 61 75 30
Cable: swedenmusic stockholm
President: Mr. Stig Anderson

CEDARWOOD (SCANDINAVIA) AB—Drottninggatan 65—STOCKHOLM C

Phone: 11 62 40
President: Mr. Ake Gerhard-Larsson

DER MUSIKUS—Farkostvagen 8—LIDINGO 1

Phone: Stockholm 65 12 30
President: Mr. Hans Busch

DOMINION AB—Storangsvagen 27—STOCKHOLM No

Phone: 61 13 16
Cable: multitone stockholm
President: Mr. Bo Goran Edling

EDITION CITY—Drottninggatan 65—STOCKHOLM C

Phone: 11 62 40
President: Mr. Ake Gerhard-Larsson

EDITION LIBERTY AB—P.O. Box 150—SOLNA 1

(Ankdammsgatan 5—Solna 1)
Phone: Stockholm 82 04 80
Cable: tefunk solna
President: Mr. Sixten Eriksson

EDITION LUNDEN—Bromsvagen 25—ALVSJO

Phone: Stockholm 47 35 46
President: Mr. Walter Cohn

EDITION ODEON—P.O. Box 27053—STOCKHOLM 27

(Sandhamnsgatan 39—Stockholm No)
Phone: 22 45 80
Cable: turntable stockholm
President: Mr. Ivan Nordstrom & Mr. Bengt Sundstrom

EDITION SYLVAIN AB—Linnegatan 9-11—STOCKHOLM O

Phone: 62 05 30
Cable: ehrlingmusik stockholm
President: Mr. Thore Ehrling

EHLING & LOFVENHOLM AB—P.O. Box 8—STOCKHOLM TULL

(Pipersgatan 29—Stockholm K)
Phone: 54 19 00
Cable: kaytone stockholm
President: Mr. Leif Kronlund

EHLINGFORLAGEN — Linnegatan 9-11—STOCKHOLM O

A concern of music publishers. For information see:
Edition Sylvain
Nils-Georgs Musikforlags AB
Thore Ehrling Musik AB

EUROPA-PRODUKTION—Drottninggatan 65—STOCKHOLM C

Phone: 11 62 40
Cable: europasong stockholm
President: Mr. Ake Gerhard-Larsson

FLAMINGO MUSIKFORLAG AB—Bergslagsvagen 260—BROMMA

Phone: Stockholm 87 33 00
President: Mr. Roland Ferneborg, Mr. Sture Wahlberg

FORLAGET FILADELFIA AB—P.O. Box 6082—STOCKHOLM 6 (Rorstrandsgatan 5—Stockholm Va)

Phone: 34 93 80
Cable: pingstkyrkan stockholm
Manager: Mr. Sven Lindahl

FORLAGET VISOR & LATAR—P.O. Box 194—AERLA (ARLA in Swedish writing) (Olstorp—Arla)

Phone: Eskilstuna (016) 700 16
President: Mr. Gunnar Olsson

GAVOTTE MUSIC AB—P.O. Box 27199—STOCKHOLM 27 (Lidingovagen 50—Stockholm No)

Phone: 63 80 89
Cable: gavottemusic stockholm
President: Mr. Klaus Lorenzen & Mr. Pierre Westerman

GEHRMANS MUSIKFORLAG AB—P.O. Box 505—STOCKHOLM 1 (Vasagatan 46—Stockholm C)

Phone: 10 09 52
Cable: musikgehrman stockholm
President: Mr. Lennart Bagger-Sjoback
Professional Manager: Mr. Bernt Baune

GRONSTEDTS MUSIKFORLAG—Borgargatan 4—STOCKHOLM Sv

Phone: 69 22 07
President: Mr. Karl Gronstedt

KARIN AB—Storangsvagen 27—STOCKHOLM No

Phone: 61 13 16
Cable: multitone stockholm
President: Mr. Bo Goran Edling

KASSNER MUSIK AB—Drottninggatan 55—STOCKHOLM C

Phone: 21 69 97
Cable: stockholmsmusik stockholm
President: Mr. Felix Stahl

KEJVING MUSIK AB — Bastugatan 45—STOCKHOLM Sv

Phone: 41 71 00
President: Mr. Walter Kejving

KEWE MUSIC—Vikingavagen—DANDERYD

Phone: Stockholm 55 78 99
President: Mr. Kewe Wickman

LOIS (SCANDINAVIA) AB—Drottninggatan 65—STOCKHOLM C

Phone: 11 62 40
President: Mr. Ake Gerhard-Larsson

MODERN MUSIC AB — Valhallavagen 16—STOCKHOLM O

Phone: 30 20 36
Director: Mr. Felix Stahl

MOONLIGHT MUSIC—Vackra vagen 14—SUNDBYBERG

Phone: Stockholm 29 15 36
President: Mr. Ake Oquist

MORGONSTJARNANS FORLAG — Kungsholmsgatan 20 — STOCKHOLM K

Phone: 51 63 87
Cable: ahlinmusik stockholm
President: Mrs. Marta Ahlin

MULTITONE AB—Storangsvagen 27—STOCKHOLM No

Phone: 61 13 16
Cable: multitone stockholm
President: Mr. Bo Goran Edling

MUSIKALISKA KNUTEN—P.O. Box 733—STOCKHOLM 1 (Idrottsvagen 52—Norrviken)

Phone: 84 06 77
President: Mr. Uno Ullven

MUSIKALISKA MAGAZINET — Drottninggatan 65—STOCKHOLM C

Phone: 11 62 40
President: Ake Gerhard-Larsson

MUSIKFORLAGET ESSEX AB—Regeringsgatan 45—STOCKHOLM C

Phone: 23 49 85
Cable: nomeco stockholm
President: Mr. Lennart Reuterskiold

NILS-GEORGS MUSIKFORLAGS AB—Linnegatan 9-11—STOCKHOLM O

Phone: 62 05 30
Cable: nilsgeorgmusik stockholm
President: Mr. Thore Ehrling
A company of the concern "Ehrlingforlagen"

NORDISKA MUSIKFORLAGET AB — P.O. Box 8—STOCKHOLM Tull (Pipersgatan 29—Stockholm K)

Phone: 54 19 00
Cable: musicalia stockholm
President: Mr. Leif Kronlund

PALACE MUSIC (SWEDEN) AB—Brahegatan 24—STOCKHOLM O

Phone: 61 75 30
Cable: swedenmusic stockholm
President: Mr. Stig Anderson

POLAR MUSIC AB—Brahegatan 24—STOCKHOLM O

Phone: 61 75 30, 60 22 87
Cable: swedenmusic stockholm
President: Mr. Stig Anderson

PROGRESSIVE AB—Storangsvagen 27—STOCKHOLM No

Phone: 61 13 16
Cable: multitone stockholm
President: Mr. Bo Goran Edling

REUTER & REUTER FORLAGS AB—Regeringsgatan 45—STOCKHOLM C

Phone: 23 49 85
Cable: nomeco stockholm
President: Mr. Lennart Reuterskiold

ROBERT MELLIN (SCANDINAVIA) AB—Drottninggatan 65—STOCKHOLM C

Phone: 11 62 40
President: Ake Gerhard-Larsson

RYMUS AB—Kungsgatan 56—STOCKHOLM C

Phone: 20 06 97
President: Mr. Henry Fox

SCALA MUSIKFORLAG AB—Regeringsgatan 45—STOCKHOLM C

Phone: 23 49 85
Cable: nomeco stockholm
President: Mr. Lennart Reuterskiold

SCHLAGERFORLAGET MUSIK AB — Hantverkargatan 62—STOCKHOLM K

Phone: 53 53 00
President: Mr. Yngve Stoor

SCREEN-GEMS MUSIKFORLAG AB—Brahegatan 24—STOCKHOLM O

Phone: 61 75 30
Cable: swedenmusic stockholm
President: Mr. Stig Anderson

THE SHADOWS MUSIC (SCANDINAVIA) AB—Drottninggatan 65—STOCKHOLM C

Phone: 11 62 40
President: Mr. Ake Gerhard-Larsson

SONET MUSIC—P.O. Box 39062—STOCKHOLM 39 (Artemisgatan 8—Stockholm No)

Phone: 67 05 40
Cable: scandicord stockholm
President: Mr. Rune Ofverman

SONORA MUSIKFORLAGS AB—P.O. Box—STOCKHOLM 27 (Lidingovagen 50—Stockholm No)

Phone: 63 59 50
Cable: sonora stockholm
President: Mr. Bo Lofberg
Professional Manager: Mr. Sture Borgedahl

SOUTHERN MUSIC AB—Grevturegatan 38—STOCKHOLM O

Phone: 67 99 10
Cable: southmusic stockholm
President: Mr. Ronald Sjogren

SPANKA MUSIC—Brahegatan 24—STOCKHOLM O

Phone: 61 75 30
President: Mr. Stig Anderson

STARTON AB—Bondegatan 4—STOCKHOLM So

Phone: 23 30 55
President: Mr. Helge Roundqvist

STOCKHOLMS MUSIKPRODUKTION—Drottninggatan 55—STOCKHOLM C

Phone: 21 69 97
Cable: stockholmsmusik stockholm
President: Mrs. Felix Stahl

SUCCEMELODIER AB—Drottninggatan 55—STOCKHOLM C

Phone: 21 69 97
Cable: stockholmsmusik stockholm
President: Mr. Felix Stahl

AB SVENSKA MANU-MUSIC—Blekingegatan 61—STOCKHOLM So

Phone: 43 07 55
President: Mr. Per Nystrom

SWEDEN MUSIC AB — Brahegatan 24 — STOCKHOLM O

Phone: 61 75 30
Cable: swedenmusic stockholm
President: Mr. Stig Anderson

THORE EHLING MUSIK AB—Linnegatan 9-11—STOCKHOLM O

Phone: 62 05 30
Cable: ehrlingmusik stockholm
President: Mr. Thore Ehrling
A company of the concern "Ehrlingforlagen"

UNITED ARTISTS MUSIKFORLAG AB—Brahegatan 24—STOCKHOLM O

Phone: 61 75 30
Cable: swedenmusic stockholm
President: Mr. Stig Anderson

WESSMAN & PETERSSON—Adelsgatan 5—VISBY

Phone: 101 11
President: Mr. Hans Pettersson

SWEDEN MUSIC AB

Brahegatan 24
STOCKHOLM · SWEDEN
Cableaddress:
SWEDEN MUSIC · STOCKHOLM
Phone:
61 75 30 · 60 22 87 · 63 79 70

STIG ANDERSON

SWEDEN — Record Manufacturers

BOKFORLAGET LIBRIS—P.O. Box 330—OREBRO 1

(Orebro Missionsforenings Forlag—Skolgatan 11—Orebro 1)
Phone: (019) 11 93 60
Cable: orebromissionen orebro
Manager: Mr. Wimar Hansson
Labels (domestic): Jubilate—Religious music

*CUPOL GRAMMOFON & MUSIK AB—Katerina Bangata 17—STOCKHOLM So

Phone: 23 30 55
Cable: cupol stockholm
President: Mr. Helge Roundquist
Labels (domestic): Cupol, Nashville, Toni
Labels (others): Ariola, Barcarola, Big Top, Cetra, Crescendo, Efel, Embassy, Eurodisc, Europa, Hansa, Kent, Music Minus One, Muza, Oriole, Palette, Pronit, Qualiton, Realm, Sveriges Radio, Time, Triola (Finland), Vega, Veriton.

ERNST WESTERBERGS FORLAGS AB—P.O. Box—STOCKHOLM 6

(Norrullsgatan 10—Stockholm Va)
Phone: 24 16 51
Cable: baptist stockholm
President: Mr. Zeth Abrahamsson
Labels (domestic): Cantus
Religious music—The Baptists

EUROPA-PRODUKTION—Drottninggatan 65 STOCKHOLM C

Phone: 11 62 40
Cable: europasong stockholm
President: Mr. Ake Gerhard-Larsson
Labels (domestic): Efel, Europa, Olga
Records distributed by Cupol Grammfon & Musik AB.

FRALSNINGSARMENS FORLAGS AB—P.O. Box 5090—STOCKHOLM 5

(Ostermalmsgatan 71—Stockholm O)
Phone: 63 17 00
Cable: fralsnings stockholm
Manager: Mr. Harry Floby
Labels (domestic): Festival
Labels (others): Regal
Religious music—The Salvation Army

FORLAGET FILADELFIA AB—P.O. Box 6082—Stockholm 6

(Surbrunnsgatan 42—Stockholm Va)
Phone: 34 93 80
Cable: pingstyrkan stockholm
President: Mr. Sven Lindahl
Labels (domestic): Hemmets Harold
Religious music—The Pentecostal Movement

*GRAMMOFON AB ELECTRA—P.O. Box 150 SOLNA 1

(Ankdammgatan 5—Solna 1)
Phone: Stockholm 82 04 80
Cable: tefunk solna
President: Mr. Sixten Eriksson
Labels (domestic): RCA Victor
Labels (others): RCA Camden, RCA Victrola

HELLBERG-PERLITZ PRODUCTION—Lilla Nygatan 16—STOCKHOLM C

Phone: 11 42 84
President: Mr. Franklin Perlitz
Labels (domestic): Rasp
Records distributed by Skandinaviska Grammfophon AB—Stockholm

HYLANDERS FORLAG—P.O. Box 35—SAVSJO

(Vastra Promenaden 2—Savsjo)
Phone: (0382) 110 05
President: Mr. Lennart Hylander
Labels (domestic): Dominant
Religious music

IBRA RADIO AB—P.O. Box 821—STOCKHOLM 1

(Sveavagen 34—Stockholm C)
Phone: 24 01 30
President: Mr. Hans Carlsson
Labels (domestic): Ibra
Religious music

JAZZ RECORDS—Nynasvagen 333—ENSKED

Phone: Stockholm 39 29 88
President: Mr. Gunnar Lindqvist
Labels (domestic): Jazz Records

*KARUSELL GRAMMOFON AB—P.O. Box—SOLNA 1

(Framnasbacken 4 B—Solna 1)
Phone: Stockholm 27 26 70
Cable: karusell stockholm
President: Mr. Simon Brehm
Labels (domestic): Joker, Karusell, Polydor, Primula
Labels (others): ABC-Paramount, Archiv-Produktion, Cameo/Parkway, Command, Coral, Deutsche Grammfophon, Heliodor, Impulse, Reprise, Starday, Swan, Swe-Disc, 20th Century Fox, United Artists, Vee Jay, Verve, Westminster

KASKAD RECORDS—P.O. Box 3134—STOCKHOLM 3

(Solvagen 8—Trollbacken)
Phone: 44 40 87
President: Mr. Lennart Broberg
Labels (domestic): Kaskad

KEWE MUSIC—Vikingavagen 15—DANDERYD

Phone: 55 78 99
President: Mr. Kewe Wickman
Labels (domestic): Wide World Records

KNAPPUPP AB—P.O. Box 3073—STOCKHOLM 3

(Kungsgatan 19—Stockholm C)
Phone: 24 07 20
Cable: ralvopro stockholm
President: Mr. Felix Alvo
Labels (domestic): Knappupp, Triola
Labels (others): Argo, California (Imperial, USA), CGD, Checker, Derby, Dot, Hickory, Kapp, Medallion

MEGAFON—Gotebergsgatan 28—Gothenburg C

Phone: (031) 20 60 96
President: Mr. Lars-Gunnar Andersson
Labels (domestic): Megafon

*METRONOME RECORDS AB—Storangsgatan 27—STOCKHOLM No

Phone: 61 06 16
Cable: metrorec stockholm
President: Mr. Mats Bjerke
Export manager: Mr. Borje Ekberg
Recording manager: Mr. Anders Burman
Labels (domestic): Metronome, Snurrskivan
Labels (others): Atco, Atlantic, Barclay, Belter, Golden 12, New Jazz, Prestige.

MOONLIGHT MUSIC—Vackra vagen 14—SUNDBYBERG

Phone: Stockholm 29 15 36
President: Mr. Ake Quist
Labels (domestic): Midnight Sun Records
Records distributed by Karusell Grammfophon AB.

MORGONSTJARNANS FORLAG—Kungsholmsgatan 20—STOCKHOLM K

Phone: 51 63 87
Cable: ahlinmusik stockholm
President: Mrs. Marta Ahlin
Labels (domestic): Morgonstjarnan
Labels (others): Ansgar
Religious music

NORDISKA MUSIKFORLAGET AB—P.O. Box 8—STOCKHOLM Tull

(Pipersgatan 29—Stockholm K)
Phone: 54 19 00
Cable: MUSICALIA STOCKHOLM
President: Mr. Leif Kronlund
Labels (domestic): Artist, Barnparaden
Records distributed by Skandinaviska Grammfophon AB

NYA BOKFORLAGS AB—P.O. Box 5020—STOCKHOLM 5

(Sibyllegatan 18—Stockholm O)
Phone: 67 01 55
President: Mr. Karl-Erik Hellberg
Labels (domestic): Angelica
Religious music—The Methodists

*AB PHILIPS-SONORA—P.O. Box—STOCKHOLM 27

(Lidingovagen 50—The Philips Building—Stockholm No)
Phone: 63 59 50
Cable: sonora stockholm
President: Mr. Bo Lofberg
Labels (domestic): Concerton, Dux, Fontana, Oktav, Pandorec, Philips, Sonata, Sonora, Svenska Ljud
Labels (others): Amadeo, Bluesville, CBS, Contemporary, Gene Norman Presents, Golden Guinea, Good Time Jazz, Jazzland, Mercury, Moodsville, Pacific Jazz, Piccadilly, Pye, Pye-Jazz, Riverside, Smash, Swingville, Vanguard, World Pacific

POLAR MUSIC AB—Brahegatan 24—STOCKHOLM O

Phone: 60 22 87, 61 75 30
Cable: swedenmusic stockholm
President: Mr. Bernt Bernhag
Labels (domestic): Polar

POPULAR MELODI—Norrbackagatan 5, I—STOCKHOLM Va

Phone: 30 16 96
President: Mr. Allan Ehwert
Labels (domestic): Pop

AB RECORD-MATERIEL—Norrbackagatan 1 STOCKHOLM Va

Phone: 23 42 15
Cable: recopress stockholm
President: Mr. Knut Vestman
Labels (domestic): Onskesagan

REKORD RECORDS—c/o Widegren—Banergatan 29, III—STOCKHOLM No

Phone: 62 03 02
President: Mr. Arne Widegren
Labels (domestic): Rekord
Distributed thru "Karusell Grammfophon AB—Solna"

SCAN-DISC RECORDING CO., AB—Grevturegatan 38—STOCKHOLM O

Phone: 67 99 14
Cable: scandisco stockholm
President: Mr. Ronald Sjogren
Labels (domestic): Pep, Polka, Scan-Disc
Labels (others): Primary, RiFi, Starday, Variety

*SKANDINAVISKA GRAMMOFON AB—P.O. Box 27053—STOCKHOLM 27

(Sandhamnsgatan 39—Stockholm No)
Phone: 22 45 80
Cable: grammophon stockholm
President: Mr. Anders Holmstedt
Labels (domestic): Columbia, His Master's Voice, Odeon, Sakral
Labels (others): Angel, Artist, Barnparaden, Biophon, Blue Note, Capitol, Charlie Parker Records, Delyse, Dolton, Electrola, Ember, Encore, Imperial, Kurre Smack, Liberty, M.G.M., Parlophone, Pathe, Rasp, Regal, Stateside, Tamla/Motown, 20th Century Fox, Vox

*SONET GRAMMOFON AB—P.O. Box 39062—STOCKHOLM 39

(Artemisgatan 8—Stockholm No)
Phone: 67 05 40
Cable: scandicord stockholm
President: Mr. Gunnar Bergstrom
Int'l & Sales mgr.: Mr. Dag Haggqvist
Labels (domestic): Gazell, Sonet, Storyville
Labels (others): Argo, Bel Air, Checker, Chess, Colpix, Debut, Discophon, Durium, Epic, Hilltop, Okeh, Pickwick 33, Red Bird, R.I.C., Riviera, Starday, Xtra

AB SVENSKA MANU-MUSIC—Blekingegatan 61—STOCKHOLM So

Phone: 43 07 55
President: Mr. Per Nystrom
Labels (domestic): Manu
Labels (others): Junior Records

SVENSKA MISSIONSFORBUNDETS FORLAG—Tegnergatan 8—STOCKHOLM Va

Phone: 34 96 80
Cable: forbundet stockholm
President: Mr. Bertil Johansson
Labels (domestic): Sirius, Solist
Religious music

SVERIGES RADIO AB—P.O. Box 930—STOCKHOLM 1

(Oxenstiernsgatan 2—Stockholm No)
Phone: 63 10 00
Cable: broadcast stockholm
Manager of record dept.: Mr. Manne Ginsburg
Labels (domestic): Sveriges Radio
Distributed thru "Cupol Grammfophon & Music AB—Stockholm and Skandinaviska Grammfophon AB

SWE-DISC GRAMMOFON AB—Bergslagsvagen 260—BROMMA

Phone: Stockholm 87 33 00
Cable: SWEDISC ISLANDSTORGET BROMMA
Presidents: Mr. Roland Ferneborg, Mr. Sture Wahlberg
Labels (domestic): Swe-Disc

SWERECO AB—P.O. Box—JOHANNESHOV 6

(Huvudskarsvagen 16—Johanneshov)
Phone: Stockholm 39 32 00
President: Mr. Arne Setterwall
Labels (others): AZ, Crown, Eros, M.K., Mode, Monitor, Pop, Saga, Sidney Bechet, Supraphon, Vogue

*TELEFUNKEN FORSALJNING AB—P.O. Box 150—SOLNA 1

(Ankdammgatan 5—Solna 1)
Phone: Stockholm 82 04 80
Cable: tefunk solna
President: Sixten Eriksson
Labels (domestic): Decca, Discofil, Pan, Sagot, Swedish Society, Telefunken, Warner Bros.
Labels (others): Ace of Clubs, Ace of Hearts, Argo, Brunswick, London, L'Oiseau-Lyre

WILLIAMS FORLAGS AB—P.O. Box 315—BROMMA 3

(Holbergsgatan 95—Bromma)
Phone: Stockholm 37 27 40
Cable: illklass stockholm
President: Mr. Bo All
Labels (domestic): Kurre Smack
Records distributed by Skandinaviska Grammfophon AB—Stockholm

*Refer to members of Swedish Association of Record Suppliers.

Throughout Scandinavia!

Local Production of
Pop and Folk Music

Distributor of
ROULETTE, KENWOOD,
HI-FI, TONO

contact:

SCAN-DISC
RECORDING COMPANY AB

For First Class
Distribution and
Exploitation of Your
Masters

GREV TUREGATAN 38
STOCKHOLM Ö
SWEDEN

cables: Scandisco

SUB-PUBLISHING IN SCANDINAVIA?

You need action & promotion

EDITION
ODEON
STOCKHOLM

BOX 27053 · STOCKHOLM · SWEDEN

SWEDEN'S BEST SELLERS

- January: 1 I Feel Fine (The Beatles/Parlophone) Sonora Musikförlags AB
2 *Fröken Fräken (Sven Ingvars/Philips) Edition Odeon
3 *Sleep Little Girl (Tages/Platina) Sonora Musikförlags AB
- February: 1 Little Honda (The Beach Boys/Capitol) Gehrmans
2 Tell Me (The Rolling Stones/Decca) Southern Music AB
3 I Feel Fine (The Beatles/Parlophone) Sonora Musikförlags AB
- March: 1 That's The Way (The Honeycombs/Pye) Sweden Music/Stig Anderson
2 Rock And Roll Music (The Beatles/Odeon) American Songs AB
3 Keep Searchin' (Del Shannon/Stateside) Belinda (Scandinavia) AB
- April: 1 Rock And Roll Music (The Beatles/Odeon) American Songs AB
2 The Last Time (The Rolling Stones/Decca) Musikförlaget Essex AB
3 *I Should Be Glad (Tages/Platina) Sonora Musikförlags AB
- May: 1 Cadillac (The Hep Stars/Olga) Copyright in dispute
2 Ticket To Ride (The Beatles/Parlophone) Sonora Musikförlags AB
3 The Last Time (The Rolling Stones/Decca) Musikförlaget Essex AB
- June: 1 Farmer John (The Hep Stars/Olga) Sonet Music
2 Cadillac (The Hep Stars/Olga) Copyright in dispute
3 Ticket To Ride (The Beatles/Parlophone) Sonora Musikförlags AB
- July: 1 Bring It On Home To Me (The Animals/Columbia) No publisher
2 Crying In The Chapel (Elvis Presley/RCA Victor) Thore Ehrling Musik AB
3 *Don't Turn Your Back (Tages/Platina) Sonora Musikförlags AB

It has been a good year in general, at least if compared with the last two or three previous years, but perhaps one could say it has been a particularly good year for local Swedish songs and artists. Of course, many local so called Beatles-groups have tried hard to reach fame, some has been very successful, among them Tages from Gothenburg in western Sweden and The Hep Stars from Stockholm. Sven Ingvars, originating from Karlstad in western Sweden offers a more conventional type of music and a hair of so called normal length, and they have, no doubt, been the most successful of all local groups, not only in Sweden but also in Norway.

*Local copyright.

SWEDEN COLLECTING SOCIETIES

S.T.I.M.
Tegnarlunden 3—Stockholm C
Phone: 24 29 50
Cable: stim stockholm
President: Dr. Sven Wilson
The Swedish Performing Rights Society/
Föreningen Svenska Tonsättares Internationella Musikbyrå.

SWEDEN RECORD DISTRIBUTORS

GRAMMOFONBOLAGENS DISTRIBUTIONS CENTRAL (GDC) AB—Dalagatan 6—STOCKHOLM C
Phone: 23 40 30
President: Mr. Eddie Landqvist
Distributor of products from the following companies: Gazell Grammofon AB, Knappupp AB, Megafon, Metronome Records AB, Polar Music AB, Scan-Disc Recording Co., Sonet Grammofon AB

THE Publisher In Scandinavia

REUTER & REUTER

Regeringsgatan 45 Stockholm C Sweden

SCANDINAVIA ?

STOCKHOLMS MUSIKPRODUKTION

..... much better!

Management: Felix and Lisbeth Stahl. Drottninggatan 55, Stockholm C.



records of Sweden

Manufacturers
Distributors
Publishers

AMERICAN SONGS AB

Drottninggatan 55, Stockholm C

proudly announces its Scandinavian representation of such important catalogues as:

ARC HARMAN JEWEL
MERRIMAC REGENT VALLEYDALE

Management: Felix and Lisbeth Stahl

NORWAY RECORD COMPANIES

ANSGAR FORLAG A/S
Møllergaten 26—OSLO 1
Phone: 42 07 47
President: Mr. Tormund Torgussen
Labels (domestic): Ansgar
Religious music

ARNE BENDIKSEN A/S
Malerhaugveien 20—OSLO
Phone: 67 67 90
Cable: BENDIKMUSIC OSLO
President: Mr. Arne Bendiksen
Labels (domestic): Hjemmets Toner, Lorne Records, Sonet, Triola, Warner Bros.
Labels (others): Argo, Baronet, Bel Air, BFB, California, Candid, Checker, Chess, Colpix, Crown, C.N.R., Debut, Deutsche Vogue, Discus Celeste, Dot, Elite Special, Emanuel,

SWEDEN GALVANIC INDUSTRIES

AB EUROPA FILM—Annedalsvagen 29—SUNDBYBERG

Phone: Stockholm 28 58 00
Cable: europafilm sundbyberg
President: Mr. Gustav Scheutz

AB SVENSK GRAMMOFONINDUSTRI—Sveavägen 17—STOCKHOLM C

Phone: 10 63 67
President: Mr. Tage Andersson

AB J. G. SODERQUIST—Idungatan 3—STOCKHOLM Va

Phone: 33 63 80
Cable: galvanomatrix stockholm
President: Mr. J. G. Soderberg

SWEDEN PRESSING PLANTS

AB ALPHA
P.O. Box—Sundbyberg 1 (Esplanaden 10—Sundbyberg)
Phone: Stockholm 28 26 00
Cable: aktiealpha stockholm
President: Mr. S. Jacobsson

AB CHAMPION RADIO
P.O. Box 21028—Stockholm 21 (Rörstrandsgatan 37—Stockholm Va)
Phone: 22 78 20
Cable: championradio stockholm
President: Mr. Olof Bengtson

MEKANISKA VERKSTADEN REKORD AB
Norrbackagatan 1—Stockholm Va
Phone: 23 42 15
Cable: recopress stockholm
President: Mr. Knut Vestman

AB SVENSK GRAMMOFONINDUSTRI
Sveavägen 17—Stockholm C
Phone: 10 63 67
President: Mr. Tage Andersson

SWEDEN RECORDING STUDIOS

COMO STUDIOS—Karlbergsvagen 57—STOCKHOLM Va
Phone: 30 96 00
Cable: metrorec stockholm
Studio manager: Mr. Rune Persson

EUROPA FILM AB—Annedalsvagen 29—SUNDBYBERG
Phone: 28 28 00
Cable: europafilm stockholm
Studio manager: Mr. Bjorn Bergqvist

SVENSKA AB PHILIPS—P.O. Box—STOCKHOLM 27 (Lidingovagen 50—Stockholm No)
Phone: 63 50 00
Cable: philamp stockholm
Studio manager: Mr. Dag Secher. Studio technician: Mr. Gert Palmcrantz

SELA STUDIO—Stortorget 5—STOCKHOLM C
Phone: 10 31 34
President: Mr. Lennart Ljungberg
Studio manager: Mr. Sten Hagberg

Embassy, Ember, Epic, Forum, Gazell, Golden Ten, Hickory, Hit Record, Imperial, Jazzville, Joy, Kapp, Knappupp, Manu, Magafon, Okeh, Old Town, Omega, Palette, Parliament, Pep Records, Phillips, Polka, Red Bird, RIC, Roost, Roulette, Scan-Disc, Special Record, Storyville, Tempo, Tiger, Vogue.

BRODRENE JOHNSEN A/S
P.O. Box 251—OSLO 1 (Nedre Slottsgate 11—Oslo 1)
Phone: 42 09 93
Cable: BRODERJOHN OSLO
President: Mr. Peer Johnsen
Labels (domestic): Rondo
Labels (others): Amadeo, Cetra, Fonit, Pye, Tono, Vox.
Records distributed by Norsk Phonogram A/S—Oslo 3

FILADELFIAFORLAGET A/S
St: Olavs gate 24—OSLO 1
Phone: 33 61 27
President: Mr. Kjell Ruud
Labels (domestic): Klango
Labels (others): Hemmets Hårøld
Religious music—The Pentecostal Movement

IVERSEN & FROGH A/S
P.O. Box 246—OSLO 1 (Youngsgate 1—Oslo 1)
Phone: 41 39 60
Cable: PLANOREFLEX OSLO
President: Mr. Arild Iversen
Publicity: Miss Gunvor Stavseth
A & R man: Mr. Rolf Syversen
Labels (domestic): Columbia, His Master's Voice, Odeon
Labels (others): Capitol, Critère, Electrola, Encore, Gloria, Imperial, Liberty, M.G.M., Parlophone, Pathe, Regal, Stateside, Tamla/Motown

JORG-FR. ELLERTSEN A/S
Jernbanetorget 4—OSLO 1
Phone: 41 26 09
Cable: TROLLMUSIC OSLO
President: Mr. Jorg-Fr. Ellertsen
Labels (domestic): Kristine Toner (religious), Troll (pop)
Labels (others): Crescendo
Records distributed by A/S Nera, Oslo

MANU MUSIC A/S
Tollbugaten 12—OSLO 1
Phone: 42 72 12
President: Mr. Per Gunnar Jensen
Manager: Mr. Per-Arne Knobelach
Labels (domestic): Emanuel, Manu
Records distributed by Arne Bendiksen A/S, Oslo

A/S NERA
P.O. Box 7033 Homansbyen—OSLO 3 (Pilestredet 75c—Oslo 3)
Phone: 46 19 50
Cable: MUSICA OSLO
President (record section): Mr. Eilif Meyer
A & R man: Mr. John Johanson
Labels (domestic): Musica, RCA Victor
Labels (others): Blue Note, Cupol, Efel, Europa, Kristine Toner, Nashville, Olga, RCA Camden, Sveriges Radio, Telefunken, Troll, Victrola.

A/S NOR-DISC—P.O. Box 1384—OSLO 1 (Rosenborggaten 19—Oslo 3)
Phone: 33 78 70
Cable: PROTON OSLO
President: Mr. Sigurd Johannessen
Labels (domestic): Karusell, Metronome, Nor-Disc, Polydor
Labels (others): ABC-Paramount, Ace of Clubs, Ace of Hearts, Archiv-Produktion, Atco, Atlantic, Beltona, Brunswick, Cameo/Parkway, Command, Commodore, Coral, Decca, Deutsche Grammophon, Felsted, Heliodor, Impulse, Joker, London, New Jazz, L'Oiseau-Lyre, Prestige, Primula, Reprise, Starday, Swe-Disc, United Artists, Vee Jay, Verve, Whitehall.

NORSK GRAMMOFONKOMPANI A/S
Wergelandsveien 1—OSLO 1
Phone: 33 40 18
Cable: NOGRAKO OSLO
President: Mr. Odd Roar Knudsen
Labels (domestic): Barneplaten, Harmoni
Labels (others): Embassy, Music Minus One, Speed-Up, Manhattan

NORSK-LUTHERSK MISSIONSSAMBAND
Grensen 19—OSLO 1
Phone: 41 76 40
Cable: NORSKLUTH OSLO
President: Mr. Tormond Vaagen
Labels (domestic): Norea
Religious music

NORSK PHONOGRAM A/S
P.O. Box 5325—OSLO 3 (Kirkeveien 64—Oslo 3)
Phone: 46 38 90
Cable: PHILIPS OSLO
President: Mr. Haakon Tveten
Publicity: Erik Roed
Label chief: Mr. Rolv Wesenlund
Labels (domestic): Cue, Fontana, Philips
Labels (others): Amadeo, CBS, Cetra, Jazzland, Mercury, Nonesuch, Piccadilly, Pye, Riverside, Rondo, Sonata, Sonora, Tono, Viking, Vox

VIKING MUSIC A/S
Pilestredet 9—OSLO 1
Phone: 33 44 53, 33 76 64
President: Mr. Kjell Karlson
Labels (domestic): Viking
Records distributed thru Norsk Phonogram A/S, Oslo 3.

Experienced Publishers

all over the world place their big hits with

GEHRMANS

Prominent Publishers of pop music in Scandinavia for more than 50 years!

CARL GEHRMANS MUSIKFORLAG
Vasagatan 46—P.O. 505, Stockholm 1,—Sweden

FINLAND—1965

Things are not what they used to be in Finland, according to the general opinion among the trade people. The business is facing the same crisis with dropping sales figures as Sweden among others, had two years ago.

Being a comparatively small country, just a little bigger than New Mexico, with a population of 4, 5 million inhabitants, it is known as "the land of the 1000 lakes". Language-wise the country is divided into two parts, the Finish-speaking part covering about 92% of the country, and Swedish-speaking part which covers around 7, 9%. Remaining 0, 1% are either Laplanders with their own language or Russian-speaking. The capital, Helsinki, is officially a two language city, with street names, etc. in Finish as well as Swedish.

Finnish record buyers are generally favouring Finish language recordings. A few artists, however have managed to break through the language barrier, such as Paul Anka, Beatles, Rolling Stones, and maybe five or ten more, but in most cases, a Finnish language recording of an international hit (it has happened also with some Beatles numbers) have every chance to become a bigger seller than the original version.

This might be described as the "old situation". Today, Finland seems to be more and more swifiting from an adults to a teenager market and teenagers seem to be more likely to accept a foreign language.

Another traditional view of Finland's music life is the Tango. Today perhaps a whole world is dancing Jenka or Letkis, so they do in Finland where those dances were created a couple of years ago, but any orchestra touring Finland will find it very difficult to be accepted unless they have a considerable number of tangos on their repertoire.

Finland has now got its "melody radio", which means that a channel of the Finnish Broadcasting Co. is airing pop music 24 hours a day. There is also a growing sale of tape recorders, and adding these two things together, the result is that records sales is going down. Some companies reports that the sale has dropped with as much as 33 per cent during the first six months of 1965.

However, in general most people is looking ahead at the future with plenty of confidence. From Sweden, where exactly the same happened a couple of years ago, they have learned that the "hard days" will come to an end and the sales figures will start growing bigger again, but as in most parts of business, the present counts much more than the future.

Finnish music people are likely to get at least some compensation for the loss at the home market from a certain income from the international market. With Letkis and Jenka being very popular in great parts of the world today, a number of Finnish recordings of this dance is finding their ways to abroad. Only a few years ago, when Finnish record production was almost 100 per cent in Finnish language, Finnish records or songs had small chances to international fame, today more and more pop records are done in English by Finnish artists, and they are not done for home consumption only.

FINLAND RECORDING STUDIOS

ELECTRO-VOX STUDIO
Neitsytpolku 1 B—Helsinki
Phone: 11 912
Cable: Nife Helsinki
President: Mr. Ernst Wallner

POHJOISMAINEN SAHKO-Oy
Vuorikatu 14—Helsinki
Phone: 12 651
Cable: Nea Helsinki
Manager: Mr. Martti Piha

SCANDIA STUDIO
Sturenkatu 4—Helsinki
Phone: 76 86 36
Manager: Mr. Jaakko Salo

Oy R. E. WESTERLUND Ab
Pohjoinen Esplanaadikatu 37—Helsinki
Phone: 10 396
Cable: Pianowesterlund Helsinki
President: Mr. Robert Westerlund

FINLAND ... RECORD COMPANIES

AKKUTEOLLISUUS Oy
Neitsytpolku 1 B—Helsinki
Phone: 11 912
Cable: Nife Helsinki
President: Mr. Ernst Wallner
Publicity: Mr. Harald Stahle
Labels (domestic): Corona
Labels (others): Cupol

Oy DISCOPHON Ab
Takomontie 3—Pitajankatu
Phone: 45 16 27
Cable: Sloy Helsinki
President: Mr. Bengt G. Liljeroth
A & R man: Mr. Johan Vikstedt
Labels (domestic): RCA Victor
Labels (others): RCA Camden, RCA Victrola.

Oy FINNDISC Ab
Simonkatu 10—Helsinki
Phone: 64 48 77, 64 49 66
Cable: Finndisc Oy Helsinki
President: Mr. Rolf Kronqvist
Labels (domestic): Safir
Labels (others): Blue Note, Nashville.

FINTONE Oy
P.O. Box 494—Helsinki
(Munkkisaarekatu 2—Helsinki)
Phone: 15 533
Cable: Fintone Helsinki
Managing Director, Record Dept.: Mr. Henrik von Denffer
Labels (domestic): Polydor
Labels (others): ABC-Paramount, Archiv-Produktion, Cameo/Parkway, Command, Coral, Deutsche Grammophon, Efel, Europa, Heliodor, Impulse, Karusell, Mercury, Olga, Primula, Riverside, SweDisch, United Artists, Vee Jay, Verve, Westminster, Whitehall.

FORSAMLINGSFORBUNDET SIRIUS
Ratakatu 29—Helsinki
Phone: 58 177
President: Mr. Bjarne Boije
Labels (others): Sirius
Religious music

IBRA RADIO LAHETYS r.y.
Pengerkatu 9—Helsinki
Phone: 77 98 54
President: Mr. Kaj Antturi
Labels (domestic): Ibra
Religious music

LEVYTUKKU Oy
P.O. Box 178—Helsinki
(Fredrikinkatu 45a—Helsinki)
Phone: 63 81 49
Cable: Levytukku Helsinki
President: Mr. Niilo Erik Saarikko
A & R man: Mr. Herbert Katz
Labels (domestic): Broadway, Manhattan, Triola

Oy MUSIIKKI-FAZER-MUSIK Ab
P.O. Box 260—Helsinki
(Aleksanterinkatu 11—Helsinki)
Phone: 10 751
Cable: Musikfazer Helsinki
President: Mr. Roger Lindberg
A & R man: Mr. Osmo Ruuskanen
Labels (domestic): Decca, Fontana, Philips, Rytmi
Labels (others): Amadeo, Artone, Barclay, California, CBS, Felsted, London, Pye, Rhythm

**MUSIIKKITALO WESTERLUND OY/
MUSICHOUSE WESTERLUND**
Pohjoinen Esplanaadikatu 37—Helsinki
Phone: 10 396
Cable: Pianowesterlund Helsinki
President: Mr. Robert Westerlund
Production manager: Mr. Eino Virtanen
Label manager: Mr. Reino Backman
Sales manager: Mr. Salomon Piwovitsch
Labels (domestic): His Master's Voice, Star
Labels (others): Capitol, Electrola, Ember, Encore, Liberty, Pathe, Stateside, Supraphon, Vox, Warner Bros.

NOR-DISC Oy
Hietalahdenranta 11—Helsinki
Phone: 64 20 05
Cable: Nordisc Helsinki
President: Mr. Antti Einio
A & R man: Jaakko Salo
Labels (domestic): Nor-Disc
Labels (others): Ariola, Athena, Atlantic, Baccarola, Belter, Cadence, Dennis, Disneyland, Eurodisc, Joker, Metronome, New Jazz, Prestige, Snurrskivan.

PELASTUSARMEIJAN KAUPPAOSASTO
City-kaytava 16-17—Helsinki
Phone: 62 57 52
President: Mr. Hellin Lindstrom
Labels (domestic): Pelastussointuja
Labels (others): Festival
Religious music, Salvation Army

POHJOISMAINEN SAHKO-Oy
Vuorikatu 14—Helsinki
Phone: 12 651
Cable: Nea Helsinki
President: Mr. Oscar Rokkanen
Manager of Music Dept.: Mr. Martti Piha
Labels (domestic): Blue Master, Columbia, Finlandia, Odeon, Parlophone
Labels (others): C.G.D., Elite Special, Metro-jazz, MGM

SCANDIA-MUSIIKKI Oy
Hietalahdenranta 11—Helsinki
Phone: 64 20 05
Cable: Scandiamusic Helsinki
President: Mr. Harry Orvomaa
Publicity: Mr. Paavo Einio
A & R man: Jaakko Salo
Labels (domestic): Scandia, Sonet.
Labels (others): Arr, Baronet, Bel Air, Big Top, Candid, Chancellor, Clan, Collector, Colpix, Coronet, Crown, Debut, Discophon, Durium, Epic, Everest, Fidelity, Forum, Funckler, Gazell, Grand Prix, Hispavox, Jazz Collector, Jazz Cool, Jazztone, Kapp, Kenwood, Kimberly, Knappupp, Megafon, M.K., Monitor, Old Town, Pep Records, Period, Red Bird, Reprise, R.I.C., Roost, Roulette, Saga, Scan-Disc, Sprint, Starday, Storyville, Vogue.

SAHKOLIIKEIDEN OY
Takomontie 3—Pitajankatu
Phone: 45 44 01
Cable: Sloy Helsinki
President: Mr. Eino Heinonen
Publicity: Mr. Johan Vikstedt
Labels (domestic): Telefunken
Labels (others): Cetra

LOTSASHOWBIZ UNDER ONE HAT

(in fact the biggest independent hat in Norway)

Looking for a good connection in Scandinavia? May we offer you our services: record dept. (the definite leading on locally produced single hits), concert agency, background music, publishing, sound equipment, recording facilities.

Local recording on Triola- and Sohet-label (constantly on the charts).

Distribution: Argo — Bel Air — Blue Note — Candid — Cash Productions — Checker — Chess — Colpix — Dimension — Debut — Dot — Elite Special — Ember — Epic — Funckler — Gazell — Hickory — Joy — Kapp — Knappupp — Loma — MK — Omega — Palette — Prima — Red Bird — Reprise — Ric — Rifi — Roulette — Scandisc — Select — Show — Sonet — Specialty Records — Storyville — Sue — Symbol — Tiger — Tip — Transatlantic — Triola — Valiant — Vox — Warner — Vogue

RECORDS SINCE 1929

Columbia
Odeon
Parlophone
M-G-M



POHJOISMAINEN SÄHKÖ-OSAKEYHTIÖ
Musical Department
Helsinki • Vuorikatu 14 • Finland

The leading Finnish independent label is now coming up strong on the international market with artists like

scandia

THE RENEGADES

(The British beat group released in all Scandinavia, Germany, Benelux, U.S.A., Canada and Japan)

JAN ROHDE and ESKO JAAKKO ORCHESTRA

(=ORIGINAL LETKISS DANCE BAND) (World famous letkiss-artists released throughout the world)

ANDY & THE ISLANDERS and THE SOUNDS
(Finnish beat groups released in all Scandinavia and Germany)

For more detailed information please contact

Scandia — Music Co. Ltd.

Hietalahdenranta 11 — Helsinki

Leading name in Finnish recording and publishing.



**ARNE BENDIKSEN AS
NORSK
MUSIKK
PRODUKSJON**
Grammofonplateavd./
record dept.
MALERHAUGVEIEN 20, OSLO
TLF. 67 67 90, CABLEADR.:
"BENDIKMUSIC"

— the progressive and trusted firm that's setting the trend in Scandinavian showbiz.

DENMARK MUSIC PUBLISHERS

ACUFF-ROSE SCANDIA—Vesterport 247—
COPENHAGEN V
Phone: PALae 5000
Cable: MUSICMORK COPENHAGEN
President: Mr. Knut Mork

DACAPO MUSIKFORLAG—Pilestraede 2—
COPENHAGEN K
Phone: Central 9549
Cable: DACAPOMUSIC COPENHAGEN
Presidents: Mr. Harry Jensen, Mr. Henry An-
dersen

DGF MUSIC—Dortheavej 39—COPENHAGEN
NV
Phone: TAgA 2282
Cable: WINCKLERMUSIC COPENHAGEN
Presidents: Mr. Gustav Winckler, Mr. Karl
Emil Knudsen

EDITION STAR—Dortheavej 39—COPEN-
HAGEN NV
Phone: TAgA 2282
Cable: WINCKLERMUSIC COPENHAGEN
President: Mr. Gustav Winckler

ENGSTRØM & SØDRING A/S—Palaegade 6
—COPENHAGEN K
Phone: Central 3228
Presidents: Mr. Knud Engstrom, Mr. Christen
Sodrings

FRANCIS DAY SCANDINAVIA A/S—Go-
thersgade 9—COPENHAGEN K
Phone: MInerva 7888
Cable: Musichansen Copenhagen
Presidents: Mrs. Hanne & Lone Wilhelm
Hansen
Professional Mgr.: Mr. Arne Spliid

IMUDICO (International Musical Distributing
Co.) A/S—Colbjørnsensgade 19—COPEN-
HAGEN V
Phone: Hilda 5625
Cable: IMUDICO COPENHAGEN
President: Mr. Albert Kleinert

MELCHER MUSIK-FORLAG—Gothersgade 9
—COPENHAGEN K
Phone: MInerva 7888
Cable: Musichansen Copenhagen
Presidents: Mrs. Hanne & Lone Wilhelm
Hansen
Professional Mgr.: Mr. Arne Spliid

MORKS MUSIKFORLAG—Vesterport 247—
COPENHAGEN V
Phone: PALae 5000, PALae 4866, PALae 9110
Cable: MUSICMORK COPENHAGEN
President: Mr. Knut Mork

MULTITONE A/S—Vibevej 31—COPENHA-
GEN NV
Phone: 34 21 28
Cable: Multitone Copenhagen
President: Mr. Harry Jensen

MUSIKPRODUKTION WINCKLER—Dorthe-
avej 39—COPENHAGEN NV
Phone: TAgA 2282
Cable: WINCKLERMUSIC COPENHAGEN
Presidents: Mr. Gustav Winckler, Mr. Karl
Emil Knudsen

PRESTO MUSIKFORLAG—Vesterport 247—
COPENHAGEN V
Phone: PALae 5000
Cable: MUSICMORK COPENHAGEN
President: Mr. Knut Mork

REG CONNELLY, MUSIK-FORLAG—Gothers-
gade 9—COPENHAGEN K
Phone: MInerva 7888
Cable: Musichansen Copenhagen
Presidents: Mrs. Hanne & Lone Wilhelm
Hansen
Professional Mgr.: Mr. Arne Spliid

TEMPO MUSIKFORLAG—Vesterport 247—
COPENHAGEN V
Phone: PALae 5000
Cable: MUSICMORK COPENHAGEN
President: Mr. Knut Mork

WILHELM HANSEN, MUSIKFORLAG—
Gothersgade 9—COPENHAGEN K
Phone: MInerva 7888
Cable: MUSICHANSEN COPENHAGEN
Presidents: Mrs. Hanne & Mrs. Lone Wilhelm
Hansen
Professional Mgr.: Mr. Arne Spliid

Denmark Record Distributors

FAELLESEKSPEDITIONEN—Vibevej 31—CO-
PENHAGEN NV
Phone: AEGir 8112
Cable: Metrorecords Copenhagen
Managing Director: Mr. Bent Fabricius-Bjerre
This distributor handles the products of the
companies: Metronome Records, Tono Gram-
mofonplader A/S.

Denmark Collecting Societies

K.O.D.A.—Kronprinsessegade 26—COPENHA-
GEN NV
Phone: Central 2277
Cable: Interkoda Copenhagen
President: Mr. Svend Erik Tarp
International Association For Protection of
Composer's Rights In Denmark/Internat-
ional Forbund til Beskyttelse af Komponis-
trettigheder i Danmark.

N.C.B.—Nordisk Copyright Bureau—Upsala-
gade 24—COPENHAGEN O
Phone: TRianon 3660
Cable: Copyright Copenhagen
President: Mr. Karl Nielsen
Mechanical licenses in Scandinavia.

Denmark Pressing Plants

FABRIKEN PLASTICA A/S—Dortheavej 1-3
—COPENHAGEN NV
Phone: AEGir 9680
Cable: Tonorecords Copenhagen
President: Mr. Harry Larsen

SKANDINAVISK BAKELITE INDUSTRI A/S
—Provensvej 35—COPENHAGEN-VANLOSE
Phone: 70 15 21
President: Mr. Marius Sorensen

SKANDINAVISK GRAMMOPHON A/S—Hof-
fdingsvej 18—COPENHAGEN-VALBY
Phone: 30 67 11
Cable: Grammophon Copenhagen
President: S. L. G. Gottlieb

Denmark Recording Studios

BIGOS STUDIO—Polensgade 7—COPENHA-
GEN S
Phone: SUnby 716
President: Mr. Borge Jensen

METRONOME RECORDS A/S—Vibevej 31—
COPENHAGEN NV
Phone: AEGir 8112
Cable: Metrorecords Copenhagen
President: Mr. Bent Fabricius-Bjerre

TONO GRAMMOPHONPLADER A/S—Dort-
heavej 1-3—COPENHAGEN NV
Phone: AEGir 9680
Cable: Tonorecords Copenhagen
President: Mr. Harry Larsen

WIFOS INGENIORSFIRMA—Nyvej 6—CO-
PENHAGEN V
Phone: EVa 5814
President: Mr. G. P. Foss

DENMARK'S BEST SELLERS

- January: 1 I Feel Fine (The Beatles/Parlophone) Multitone A/S
2 *Let's Go (Sir Henry and His Butlers/Sonet) Musikproduktion
Winckler
3 Little Red Rooster (The Rolling Stones/Decca) No publisher
- February: 1 I Feel Fine (The Beatles/Parlophone) Multitone A/S
2 Tell Me (The Rolling Stones/Decca) Southern Music AB
3 I Could Easily Fall In Love (Cliff Richard/Columbia) Belinda
(Scandinavia) AB
- March: 1 Lille fregnede Louise (Fröken Fräken) (Johnny Reimer/Phil-
lips) Imudico A/S
2 Tell Me (The Rolling Stones/Decca) Southern Music AB
3 Mashed Potatoes (The Defenders/Sonet) Robert Mellin (Scan-
dinavia) AB
- April: 1 Lille fregnede Louise (Fröken Fräken) (Johnny Reimer/Phil-
lips) Imudico A/S
2 Rock And Roll Music (The Beatles/Odeon) American Songs AB
3 The Last Time (The Rolling Stones/Decca) Musikförlaget Es-
sex AB
- May: 1 Poupée de Cire, Poupée de Son (France Gall/Philips) Multi-
tone A/S
2 Rock And Roll Music (The Beatles/Odeon) American Songs AB
3 The Last Time (The Rolling Stones/Decca) Musikförlaget Es-
sex AB
- June: 1 Rock And Roll Music (The Beatles/Odeon) American Songs AB
2 Poupée de Cire, Poupée de Son (France Gall/Philips) Multi-
tone A/S
3 The Last Time (The Rolling Stones/Decca) Musikförlaget Es-
sex AB
- July: 1 Heart Of Stone (The Rolling Stones/Decca) No publisher
2 The Birds And The Bees (The Defenders/Sonet) No publisher
3 Ticket To Ride (The Beatles/Parlophone) Multitone A/S
- *Local copyright.

DENMARK — Record Companies

AEG DANSK ELEKTRISITETS A/S—Nyro-
psgade 18—COPENHAGEN V
Phone: Central 5000
Cable: Elektrongea Copenhagen
President: Mr. John L. Bryholt
Assistant manager: Mr. Vilhelm Hoy
Labels (others): Cupol, Efel, Europa, Nash-
ville, Olga, Swedish Society, Telefunken.

I. S. DANSK GRAMMOPHONPLADEFORLAG
—Dortheavej 39—COPENHAGEN NV
Phone: TAgA 8505
Cable: Danrecord Copenhagen
President: Mr. Karl Emil Knudsen
Publicity: Per Sorensen
A&R men: Gustav Winckler & Per Sorensen
Labels (domestic): Debut, Ecco, Life, Mascot,
Sonet, Storyville
Labels (others): Artist, Colpix, Fabor, Gazell,
Old Town, Palette, Red Bird, RIC, Roulette,
Savoy, Supraphon, Vega.
Labels (others): Artist, Colpix, Epic, Fabor,
Gazell, Okeh, Old Town, Palette, Red Bird,
RIC, Roulette, Savoy, Supraphon, Vega.

FELIX FILM OG GRAMMOPHON—Bernstoffs-
gade 21—COPENHAGEN K
Phone: MInerva 2543
President: Mr. Ejnar Christensen
Labels (domestic): Felix
Labels (others): Cantate

HEDE NIELSEN'S FABRIKKER A/S—
Grundtvigsvej 10a—COPENHAGEN V
Phone: EVa 4120
Cable: Henigram Copenhagen
Pres.: Mr. Ove Hede Nielsen
General Manager: Mr. Elith Henriksen
Publicity: Mr. Ivan Meldgaard
Labels (domestic): RCA Victor
Labels (others): RCA Camden, Reprise, Vic-
trola, Warner Bros.

KARUSELL GRAMMOPHON A/S—Dortheavej
39—COPENHAGEN NV
Phone: TAgA 8505
Cable: Danrecord Copenhagen
President: Mr. Karl Emil Knudsen
Publicity: Per Sorensen
Labels (domestic): Joker, Karusell
Labels (others): ABC-Paramount, Baccorola,
Cameo/Parkway, Durium, Eurodisc, Im-
pulse, Paris, Primula, Reprise, Starday,
Swan, Top Rank, 20th Fox, Vee Jay.

KORSET'S EVANGELIUM'S FORLAG—
Kronprinsensgade 7—COPENHAGEN K
Phone: PALae 3808
Managers: Mr. Sv. Aage Svendsen & Mr. W.
Hagstrom
Labels (domestic): Korsets Evangelium
Labels (others): Hemmets Harold, Klango
Religious music—The Pentecostal Move-
ment

METRONOME RECORDS A/S—Vibevej 31—
COPENHAGEN NV
Phone: AEGir 8112
Cable: Metrorecords Copenhagen
President: Mr. Bent Fabricius-Bjerre
Publicity: Olav Bennike
Labels (domestic): Metronome
Labels (others): Atco, Atlantic, Belter, Golden
12, New Jazz, Prestige, Snurrskivan, Spax.

MORKS MUSIKFORLAG—Vesterport 247—
COPENHAGEN V
Phone: PALae 5000, 4866, 9110
Cable: Musicmork
President: Mr. Knut Mork
Publicity: Mr. Aage Nyman
Labels (domestic): Triola
Labels (others): Austroton, CGD, Derby, Dot,
Elite Special, Golden Guinea, Hickory, Kapp,
Knappupp, Picadilly, Pye.

NORDISK POLYPHON A/S—Emdrupvej 115
—COPENHAGEN NV
Phone: 69 25 22
Cable: Polyphon Copenhagen
President: Mr. Werner Hamburger

Sales Manager: Mr. John Winkelmann
Label Managers: Mr. Andreas Arfmann
(DGG, Polydor), Mr. H. Rosenlow-Jensen
(Decca), Mr. Owe Wiisholm (CBS, Mer-
cury, Philips)
Recording Chief: Mr. Svend Dethmer
Advertising Manager: Mr. Carl Andersen
Labels (domestic): Philips, Polydor, Polyphon
Labels (others): Ace of Clubs, Ace of Hearts,
Archiv-Produktion, Battle, Beltona, Bruns-
wick, Carlton, CBS, Challenge, Command,
Coral, Decca, Deutsche Grammophon, Dixie-
land Jubilee, Era, Felsted, Fontana, Goo!
Time Jazz, Heliodor, Hi-Fi, Hi-Fi Jazz,
Jamie, Jazzland, Jubilee, London, Mercury,
Monument, NCR, Off Beat, L'Oiseau-Lyre,
Pacific Jazz, Riverside, Smash, Sonata,
Sonora, Specialty, Sun, United Artists,
Verve, Vocalion, Warwick, Washington,
Wonderland, World Pacific

SKANDINAVISK GRAMMOPHON A/S—
Hoffdingsvej 18—COPENHAGEN-VALBY
Phone: 30 67 11
Cable: Grammophon Copenhagen
President: Mr. S. L. G. Gottlieb
Publicity: Mr. Kurt Hvuid-Mikkelsen
Labels (domestic): Columbia, His Master's
Voice, Odeon
Labels (others): Capitol, Critere, Electrola,
Encore, Epic, HMV-Angel, Imperial,
Liberty, M.G.M., Parlophone, Pathe, Regal-
Zonophone, Stateside, Tamla/Motown, Vox.

TIVOLIPHON—Fredriksberg Alle 25—CO-
PENHAGEN V
Phone: Hilda 2768
President: Mr. Asger Lund-Christensen
Labels (domestic): Tivoliphon

TONO GRAMMOPHONPLADER A/S—Dort-
heavej 1-3—COPENHAGEN V
Phone: AEGir 2300, 9680
Cable: Tonorecords Copenhagen
President: Mr. Harry Larsen
Publicity: Mr. T. Lützer
A & R men: Mr. E. Ollgard & Mr. Svend
Hansen
Labels (domestic): Teener, Tono
Labels (others): Amadeo, Barclay, Bel Air,
Durium, Embassy, Fonit, GNP, Jazz Selec-
tion, Majestic, Mode, Oriole, Pop, Ronnex,
Swing, Vogue.

For the BEST
promotion of your
hits

MULTITONE A/S
Vibevej 31
Copenhagen NV—Denmark

Has the BEST
connections with
the leading Record
Companies in
Scandinavia

SERVING THE INTERNATIONAL MUSIC BUSINESS

FASTEST RECORD DELIVERY THROUGHOUT THE WORLD BY AIR MAIL
COMPLETE LINE OF ALL AMERICAN LABELS

ALL NEW RELEASES

AIRDISC U.S.A.

SINGLES • ALBUMS

Every quantity shipped. Prices
on request.

Box 545, Radio City Station
New York, N. Y. 10019

Payments by bank draft or In-
ternational Money Order or on
account.

TONO

for more than 25 years
biggest independent company
in DENMARK

★
own studio

★
own processing
and pressing plant

★
guarantee your label
an efficient and nation-wide
distribution in Denmark

★
COPENHAGEN NV

1 Dortheavej Phone AEGIR 9680

TONO

NORWAY'S BEST SELLERS

- January: 1 I Feel Fine (The Beatles/Parlophone) Edition Lyche
2 If I Fell (The Beatles/Odeon) Edition Lyche
3 I Guess I'm Crazy (Jim Reeves/RCA Victor) No publisher
- February: 1 I Feel Fine (The Beatles/Parlophone) Edition Lyche
2 I Could Easily Fall In Love (Cliff Richard/Columbia) Belinda (Scandinavia) AB
3 If I Fell (The Beatles/Odeon) Edition Lyche
- March: 1 Fröken Fräken (Sven Ingvars/Philips) Carl M. Iversen A/S
2 Rock And Roll Music (The Beatles/Odeon) American Songs AB
3 Jeg marsjerer ved din side (Royal Telephone) Wenche Myhre/Triola Belinda (Scandinavia) AB
- April: 1 Fröken Fräken (Sven Ingvars/Philips) Carl M. Iversen A/S
2 Rock And Roll Music (The Beatles/Odeon) American Songs AB
3 It Hurts So Much (Jim Reeves/RCA Victor) No publisher
- May: 1 Rock And Roll Music (The Beatles/Odeon) American Songs AB
2 Ticket To Ride (The Beatles/Parlophone) Edition Lyche
3 Det var i vår ungdoms fagreste vår (Sven Ingvars/Philips) Sonora Musikförlags AB
- June: 1 Ticket To Ride (The Beatles/Parlophone) Edition Lyche
2 King Of The Road (Roger Miller/Philips) Palace Music/Stig Anderson
3 Där björkarna susa (The Jailbird Singers/Metronome) Norsk Musikforlag A/S
- July: 1 Där björkarna susa (The Jailbird Singers/Metronome) Norsk Musikforlag A/S
2 King Of The Road (Roger Miller/Philips) Palace Music/Stig Anderson
3 Cadillac (The Hep Stars/Olga) Copyright in dispute

1965 has been a very good year for Swedish artists at the Norwegian market. Sven Ingvars, a Philips recording group from western Sweden, topped the charts in March and April with their Swedish copyright "Fröken Fräken," and went high in May with another Swedish oldie, "Det var i vår ungdoms fagreste vår." They sold well enough to get one or two Silver Disks for the sale of 25,000 records. In June, another Swedish group, Metronome recording The Jailbird Singers (the group was founded in a Swedish jail of some prisoners who hoped to make a career after their release, but the group was dissolved when the leader died of cancer in beginning of 1965) entered the charts with the Swedish oldie "Där björkarna susa," and topped the charts in July. In the middle of July, another Swedish group, The Hep Stars, recording for the Olga label, topped the charts with their recording of "Cadillac."

The Beatles continued to do excellent business in Norway also in 1965, but they were offered very strong competition from late Jim Reeves, who has sold better in Norway than in any other country of the world, including United States, when considering the number of records sold and the population of Norway.

NORWAY MUSIC PUBLISHERS

ARNE BENDIKSEN A/S
Malerhaugveien 20—OSLO
Phone: 67 67 90
Cable: RENDIKMUSIC OSLO
President: Mr. Arne Bendiksen

CARL M. IVERSEN A/S
P.O. Box 191—OSLO 1
(Youngsgate 1—Oslo 1)
Phone: 41 38 67
Cable: CEMIYOUNG OSLO
President: Mr. Arild Iversen

EDITION LYCHE
Kongens gate 2—OSLO 1
Phone: 41 44 85, 41 34 64
Cable: EDILYCH OSLO
General manager: Mr. Philip Kromer

JORG-FR. ELLERTSEN A/S
Jernbanetorget 4—OSLO 1
Phone: 41 26 09
Cable: TROLLMUSIC OSLO
President: Mr. Jorg-Fr. Ellertsen

MANU MUSIC A/S
Tollbugaten 12—OSLO 1
Phone: 42 72 12
President: Mr. Per Gunnar Jensen

MUSIKK-HUSET A/S
P.O. Box 1459—OSLO 1
(Karl Johans gate 45—Oslo 1)
Phone: 42 17 03
President: Mr. Sigurd Kielland
Publicity: Mr. Arne Damsgaard

NORSK MUSIKFORLAG A/S
P. O. Box 1499—OSLO 1
(Karl Johans gate 39—Oslo 1)
Phone: 41 49 03
Cable: MUSIKFORLAGET OSLO
President: Mr. Fridtjof Backer—Gröndahl

OSCAR SKAUS MUSIKKHANDLEL & FORLAG A/S—Edv. Storms gate 1—OSLO 1
Phone: 33 49 66
Cable: MUSIKSKAU OSLO
President: Mr. Oscar Skau

SKANDIA MUSIKPRODUKSJON A/S
Pilestredet 9—OSLO 1
Phone: 33 44 53
President: Mr. Finn Eriksen

VIKING MUSIC A/S
Pilestredet 9—OSLO 1
Phone: 33 44 53
President: Mr. Kjell Karlsen

NORWAY GALVANIC INDUSTRIES

NORSK RIKSKRINGKASTING
Bjornstjerne Bjornsens Plass 1—Oslo NV
Phone: 46 38 20
Cable: Studio Oslo
Manager: Mr. Rolf Glosly

A/S RADIO INDUSTRI
Sandakerveien 16—Oslo 4
Phone: 37 56 80
President: Mr. D. W. van der Sijde

NORWAY RECORDING STUDIOS

ARNE BENDIKSEN A/S
Malerhaugveien 20—Oslo
Phone: 67 67 90
Cable: Monnmusic Oslo
President: Mr. Egil Monn-Iversen

IVERSEN & FROGH A/S
P.O. Box 246—Oslo 1
(Youngsgate 1—Oslo 1)
Phone: 41 39 60
Cable: Planoreflex Oslo
President: Mr. Arild Iversen

NORSK GRAMMOFONKOMPANI A/S
Wergelandsveien 1—Oslo 1
Phone: 33 40 18
Cable: Nograko Oslo
President: Mr. Odd Roar Knudsen

PRESSING PLANTS NORWAY

HEGER PLASTICS A/S
Kjelsasveien 141—OSLO 4
Phone: 21 72 17
Cable: HEPLAST OSLO
President: Mr. Ragnar Heger

NORSK PHONOGRAM A/S
P.O. Box 5040 Majorstua—OSLO 3
(Sorkedalsveien 6—Oslo 3)
Phone: 46 38 90
Cable: PHILIPS OSLO
President: Mr. Haakon Tveten

NORSK GRAMMOFONKOMPANI A/S
Wergelandsveien 1—OSLO 1
Phone: 33 40 18
Cable: NOGRAKO OSLO
President: Mr. Odd Roar Knudsen

NORSK TEKNISK PORSELEN—FABRIKK
Seiersborg—FREDRIKSTAD
Phone: 5900
President: Mr. Peter Barfoed

Collecting Societies

T.O.N.O.
Klingenberggate 5—OSLO 1
Phone: 42 18 08
Cable: TONO OSLO
President: Mr. Ragnar Kjerrulf
Norsk Komponistforenings Internasjonale Musikbyrå/The Norwegian Copyright Bureau.

Oy AIRAM Ab
Pursimiehenkatu 29-31—Helsinki
Phone: 11 431
Cable: Airam Helsinki
President: Mr. Henrik Bergroth

AKKUTEOLLISUUS Oy
Sahatie 2—Helsinki
Phone: 11 912
Cable: Nife Helsinki
President: Mr. Ernst Wallner

FINLAND'S BEST SELLERS

Finland has been and still is one of those countries where the local language is the best guarantee for a hit. There are, of course, exceptions, like Beatles, etc., but from time to time also a local Finnish-language version of a Beatles hit record has offered great competition to the British idols.

- January: 1 Nousevan auringon talo (The House Of The Rising Sun) (Lasse Mårtensson/Philips) Fazer Music
2 I Should Have Known Better (The Beatles/Parlophone) Fazer Music
3 The House Of The Rising Sun (The Animals/Columbia) Fazer Music
- February: 1 *Tango Pelargonina (Kari Kuuva/Scandia) Scandia Music
2 Cadillac (The Renegades/Scandia) Copyright in dispute
3 Nousevan auringon talo (The House Of The Rising Sun) (Lasse Mårtensson/Philips) Fazer Music
- March: 1 *Tango Pelargonina (Kari Kuuva/Scandia) Scandia Music
2 I Feel Fine (The Beatles/Parlophone) Fazer Music
3 Cadillac (The Renegades/Scandia) Copyright in dispute
- April: 1 *Tango Pelargonina (Kari Kuuva/Scandia) Scandia Music
2 Rock And Roll Music (The Beatles/Parlophone) American Songs AB
3 Gabrielle (The Hooten Singers in Finnish/RCA Victor) Scandia Music
- May: 1 Rock And Roll Music (The Beatles/Parlophone) American Songs AB
2 Pikku Nina (Norma) (Kari Kuuva/Scandia) Scandia Music
3 *Tango Pelargonie (Kari Kuuva/Scandia) Scandia Music
- June: 1 Pikku Nina (Norma) (Kari Kuuva/Scandia) Scandia Music
2 Rock And Roll Music (The Beatles/Parlophone) American Songs AB
3 *Minne tuuli kuljettaa (Katri Helena/Parlophone) X-Sävel
- July: 1 *Minne tuuli kuljettaa (Katri Helena/Parlophone) X-Sävel
2 Pikku Nina (Norma) (Kari Kuuva/Scandia) Scandia Music
3 The Last Time (The Rolling Stones/Decca) Musikförlaget Essex AB

*Local copyright.

FINLAND'S MUSIC PUBLISHERS

EDITION CODA—Ritokalliontie 8/16 P—
HELSINKI
Phone: 45 16 27
President: Mr. Johan Vikstedt

Oy FINNDISC Ab
Simonkatu 10 B—Helsinki
Phone: 64 48 77
Cable: Finndiscy Helsinki
President: Mr. Rolf Kronqvist

LEVYSÄVEL Oy
Vuorikatu 14—Helsinki
Phone: 12 651
Cable: Levysavel Helsinki
President: Mr. Martti Jappila
Publicity: Mr. Martti Piha

LEVYTUKKU Oy—P.O. Box 178—Helsinki
(Fredrikinkatu 45—Helsinki)
Phone: 38 149
Cable: Levytukku Helsinki
President: Mr. Niilo Erik Saarikko

FINLAND

Collecting Societies

T.E.O.S.T.O.—Hietaniemenkatu 2—HELSINKI
Phone: 44 85 09
Cable: Teosto Helsinki
President: Mr. Martti Turunen
Säveltäjain Tekijänoikeustoitimisto / Tonsattärnas Copyright Byrå/Finnish Copyright Bureau.

Belgium—(Continued from page 79)

BELGIAN—PRESSING PLANTS

SOBEDI S.A.
Waalse Krook, Ghent, phone 09-254760.
Managing director: Fernand Janssens.

DISCOPRESS
rue Gallait, 88, Brussels, phone 161640.
Managing director: Mr. Braunstein.

FABELDIS
St.—Mariastraat, 4-10, Brussels 8, phone 256501-254010.
Managing director: M. de Wallens.

Belgium—(Continued from page 74)

HOLLAND'S LIST OF BEST SELLERS PAST 12 MONTHS

- The French Song (Lucille Starr/London) (Altona/Amsterdam)
- Pretty Woman (Roy Orbison/London) (Internationale Muziek Co./Amsterdam)
- Letskiss (Stig Rauno/Barclay, Gudrun Jankis/Omega, Jan Rohde & The Wild Ones/Delta) (Altona/Amsterdam)
- I Feel Fine (Beatles/Parlophone) (Basart/Amsterdam)
- It's All Over Now (Rolling Stones/Decca) (Leeds Holland-Basart/Amsterdam)
- A Hard Day's Night (Beatles/Parlophone) (Leeds Holland-Basart/Amsterdam)
- The Birds And The Bees (Jewel Akens/London) (Altona-Palace Music Holland/Amsterdam)
- Colinda (Lucille Starr/London) (Holland Music/Amsterdam)
- A Ticket To Ride (Beatles/Parlophone) (Leeds Holland-Basart/Amsterdam)
- The Last Time (Rolling Stones/Decca) (Essex-Basart/Amsterdam)
- Mijn Dagboek (My Diary) Willeke Alberti/Philips) (Portengen/Haarlem)
- Liebeskummer Lohnt Sich Nicht (Siv Malmkvist/Metronome) (Anagon Music Publishers/Heemstede)
- Doce Paola (Adamo/H.M.V.) (Anagon Music Publishers/Heemstede)
- Rock And Roll Music/No Reply (Beatles/Parlophone) (Basart/Amsterdam)
- Quand Les Roses (Adamo/Pathé) (Anagon Music Publishers/Heemstede)
- I Should Have Known Better (Beatles/Parlophone) (Basart/Amsterdam)
- Les Filles Du Bord De Mer (Adamo/H.M.V.) (Anagon Music Publishers/Heemstede)
- Eight Days A Week (Beatles/Parlophone) (Basart/Amsterdam)
- If I Fell (Beatles/Parlophone) (Basart/Amsterdam)
- I Could Easily Fall (Cliff Richard/Columbia) (Belinda/Amsterdam)

WORLD WIDE MUSIC DIRECTORY

(Continued from page 118)

TURKEY

RECORD MFRS

AMERIKAN NESRIYATI BÜROSU—Saka Selim Cik-mazi 7—Beyoğlu—ISTANBUL
Phone: 44 26 36
Cable: CAGLAYAN ISTANBUL
Pres.: Mr. Kayihan Caglayan
Labels (domestic): Melodi
Labels (others): Atlantic, Cetra, Decca, London, RCA Camden, RCA Victor, Ri-Fi.

ELIA ALUF MEDINA ve ORTAKLARI PLAKCILIK KOLLEKTIF SIRKETI—Posta Kutusu 684—Galata—ISTANBUL
(Necatibey Caddesi—Seref Han 303—Galata—Istanbul)
Phone: 44 99 64, 48 45 81
Cable: MEALUF ISTANBUL
Pres.: Mr. Elia Aluf Medina
Labels (others): Cricket, Fonit, Fonola, Maietti, Zephyr.

GRAFSON SANAYI ve TICARET KOLLEKTIF SIRKETI—Tiyatro Caddesi—Aydin Saray 3cu Kat 132-135—Beyazit—ISTANBUL
Phone: 22 20 80
Cable: PLAKTÜRK ISTANBUL
Pres.: Mr. Agop Urgüplüoğlu
Labels (domestic): Grafson
Labels (others): Barclay, Durium

JAK GRÜNBERG HALEFLERI HUGO ve LEON GRÜNBERG—Posta Kutusu 533—ISTANBUL
(Rizapasa Yokusu—Milas Han—Istanbul)
Phone: 22 48 26, 22 48 27
Cable: ODEON ISTANBUL
Pres.: Mr. Hugo Grünberg, Mr. Leon Grünberg
Labels (domestic): Odeon
Labels (others): Carisch, Parlophone

TURK PHILIPS TICARET ANONIM SIRKETI—Posta Kutusu 504—Beyoğlu—ISTANBUL
(Gümüssuyu Caddesi 78-80—Beyoğlu—Istanbul)
Phone: 44 74 86
Cable: PHILIPS ISTANBUL
Pres.: Mr. A. G. van Rongen
Labels (domestic): Fontana, Philips

VAHRAM GESAR & CO.—Mumhane caddesi 20—Galata—ISTANBUL
Phone: 44 45 32, 44 51 23, 44 88 02
Cable: KEUPEK ISTANBUL
Pres.: Mr. Mihran Gesar
Labels (domestic): Sahibinin Sesi
Labels (others): Electrola, His Master's Voice, M.G.M., Voce del Padrone, Voix de Son Maitre.

PRESSING PLANTS

GRAFSON SANAYI ve TICARET KOLLEKTIF SIRKETI—Tiyatro Caddesi—Aydin Saray 3cu Kat 132-135—Beyazit—ISTANBUL
Phone: 22 20 80
Cable: PLAKTÜRK ISTANBUL
Pres.: Mr. Agop Urgüplüoğlu, Mr. Mihran Gürciyan

GRAMOFON LİMİT SIRKETI—Posta Kutusu 3—Yesilkoy—ISTANBUL
(Haikali Caddesi 85—Yesilkoy—Istanbul)
Phone: 73 89 76, 73 89 77
Cable: GRAMOTÜRK ISTANBUL
Pres.: Mr. Alan A. Campbell

MELODI PLAK ve SES ENDÜSTRİSİ—Maltepe yolu 9—Rami—ISTANBUL
Phone: 47 12 42
Cable: MELODI ISTANBUL
Pres.: Mr. Kayihan Caglayan

UGANDA

RECORD MFRS

ASSANAND & SONS (UGANDA) LTD.—P.O. Box 577—KAMPALA
(54-60 Kampala Road—Kampala)
Phone: 3150
Cable: ASSANAND KAMPALA
Pres.: Mr. D. Pal Assanand
Labels (domestic): Habari
Labels (others): Capitol, Columbia, Decca, His Master's Voice, Pye, RCA Victor, etc.

UNITED ARAB REPUBLIC (U.A.R.)

RECORD MFRS

CAIROPHON COMPANY—P.O. Box 113—CAIRO
(34 sharia Mousky—Cairo)
Phone: 51903, 49642, 49396
Cable: CAIROPHON CAIRO
Pres.: Mr. Pierre B. Baida
Labels (domestic): Baidaphon, Cairophon

DECCA-BRUNSWICK GRAMMOPHONE STORES—3 Borsa el Guedida Street (Kasr el Nil)—CAIRO
Phone: 47083
Pres.: Mr. Aristote Zoulakis
Labels (others): Ace of Hearts, Beltona, Brunswick, Coral, Decca, London, L'Oiseau-Lyre, RCA Victor, Telefunken, Warner Bros.

MICHAEL YACOUMOPOULOS—P.O. Box No. 1904—ALEXANDRIA
(28 Saad Zaghloul Street—Alexandria)
Phone: 30934
Cable: YALOS ALEXANDRIA
Pres.: Mr. Michael Yacoumopoulos
Labels (others): Capitol, Columbia, His Master's Voice, Parlophone

MIRTOUCHE RECORDS—9, Fawzi El Motei Street—Heliopolis—CAIRO
Phone: 66401
Pres.: Mr. Karim Shukry
Labels (domestic): Mirtouche

SONO RADIO-MISRPHON—Post Office Bag—CAIRO
(33, Kasr El Nil Street—Cairo)
Phone: 40978
Cable: CHARCAIRO CAIRO
Pres.: Mr. Hazem El Nahry
Labels (domestic): Misrphon, Sono Radio

URUGUAY

MUSIC PUBLISHERS

DISCOTECA, S.R.L.—Maldonado 1049—MONTEVIDEO
Phone: 98 58 32
Cable: CLALIM MONTEVIDEO
Pres.: Mr. Leon Jurburg
Including "Ediciones Musicando" and "El Hornero"

EDITORIAL EDAMI—Juan D. Jackson 1410—MONTEVIDEO
Phone: 40 15 40
Cable: EDAMI MONTEVIDEO
Pres.: Miss Gladys A. De Mancuso

RECORD MFRS

CASA PRAOS S.A.—Avenida 18 de Julio 1080—MONTEVIDEO
Phone: 95 034, 84 970, 98 03 46, 98 03 47
Cable: PRAOS MONTEVIDEO
Pres.: Mr. Ricardo Sparano
Labels (domestic): Gold-Laut
Labels (others): Gema, Magison, Musidisc

CLAVE, I.E.M.S.A.—Maldonado 1049—MONTEVIDEO
Phone: 98 58 37
Cable: CLALIM MONTEVIDEO
Pres.: Mr. Leon Jurburg
Labels (domestic): Clave
Labels (others): Barclay, CGD, Continental, Discmoda, Kubaney, London, Marvela, Microfon, Panart, Seeco, T.K.

SONDOR S.A.—Nicaragua 1478—MONTEVIDEO
Phone: 27 530, 28 801
Cable: SONDORADA MONTEVIDEO
Pres.: Enrique Abal Salvo
Labels (domestic): Sondor
Labels (others): Calesita, CBS, Dot, Music Hall, Reprise.

PRESSING PLANTS

SONDOR S.A.—Nicaragua 1478—MONTEVIDEO
Phone: 27 530, 28 801
Cable: SONDORADA MONTEVIDEO
Pres.: Mr. Enrique Abal Salvo

U. S. S. R.

EXPORT & IMPORT

V/O MEZHUNARODNAJA KNIGA—Smolenskaja-Sennaja 32-34—MOSCOW G-200
Phone: 8-4-1022
Cable: MEZHKNIGA MOSCOW G-200
Pres.: Mr. S. V. Pankratov
Labels (domestic): MK
Only organization to be contacted in questions of export or import of ready made cultural goods (records and sheet music editions).

VENEZUELA

COLLECTING SOCIETIES

A.V.A.C.—ASOCIACION VENEZOLANA DE AUTORES Y COMPOSITORES—Apartado 10233—CARACAS
(Edificio Camuri—Calle Real de Sabana Grande—Caracas)
Phone: 71 31 72
Cable: AVAC CARACAS
Pres.: Mrs. Marie Luisa Escobar
Performing Rights Society

MUSIC PUBLISHERS

PEER INTERNACIONAL DE VENEZUELA—Apartado 941—CARACAS
(Avenida Andres Bello—Edificio "Vam"—Caracas)
Phone: 54-6786
Cable: IDROCIR CARACAS
Pres.: Mr. Alfonso Sanchez Lopez

RECORD MFRS

COMERCIAL SERFATY C.A.—Apartado 2199—CARACAS
(Esquina y Edificio Las Piedras—Caracas)
Phone: 41-8101
Cable: COSERCA CARACAS
Pres.: Don Rafael A. Serfaty
Labels (domestic): Billo, Serfaty, Turpial
Labels (others): Alegria, Belter, Fonit, Iberofone, Pacific, SAEF, Zafiro.

DISTRIBUIDORA NACIONAL DE DISCOS S.A.—Apartado 8535—CARACAS
(Rio a Puente Soublette—Edificio Andrea Doria—Local G—Caracas)
Phone: 42-2019, 41-4062
Cable: DISNADISCO CARACAS
Pres.: Mr. Jose Page Barrios
Labels (domestic): Velvet
Labels (others): Audio Fidelity, Discuba, Gema, Kubaney, Puchito

DON DISCO, C.A.—Apartado 7607—CARACAS
(Plaza de Chacaito—Caracas)
Phone: 81-0747, 82-0823, 71-8056
Cable: DONDISCO CARACAS
Pres.: Mr. Gervasio Garcia Mundet
Labels (domestic): Dondisco
Labels (others): Angel, Capitol, Columbia, Electrola, Epic, Harmony, His Master's Voice, Odeon, Pathé, etc.

EL PALACIO DE LA MUSICA S.A.—Apartado 3637—CARACAS
(Guayabal a Venado No 4-1—Caracas)
Phone: 42-8826
Cable: PAMUSICA CARACAS
Pres.: Mr. Ernesto Aue
Labels (domestic): Palacia
Labels (others): Ariola, Colpix, Copacabana, Crescendo, Daro, Falcón, Imperial, London, Peerless, Rapsodia, Rico-Vox, Seeco, United Artists

FABRICA VENEZOLADA DE DISCOS C.A.—Apartado 3402—CARACAS
(Cuarto Calle—Ciudad Industrial Carapa—Caracas)
Phone: 24178, 23867
Cable: FAVEDICA CARACAS
Pres.: Mr. César Roldán
Labels (domestic): Discmoda
Labels (others): Cameo/Parkway, Musidisc, Music Hall, Odeon, Warner Bros.

GRABACIONES "GRAMCKO" C.A.—Apartado de Correos 203—CARACAS
(Avenida Baralt—Esquina Maderera—Edificio Caraballa-Gramcko—Caracas)
Phone: 41-7130, 41-7350
Cable: CARABELLO GRAMCKO CARACAS
Pres.: Mr. Manuel H. Caraballo-Gramcka, hijo
Labels (domestic): Gramcko

INDUSTRIA NACIONAL DEL SONIDO, VENEVOX C.A.—Apartado 4151 Chacao—CARACAS
(Calle Capitolio—Edificio Venevox—Boleita, Estado Miranda)
Phone: 34-8272
Cable: ELECTRONIC CARACAS
Pres.: Mr. Charles Biderman
Labels (domestic): Diversion, Venevox
Labels (others): Alborada, Alhambra, Barclay, Cetra, Disneyland, Ducretet-Thomson, Durium, Festival, Kapp, Montilla, Ricordi, Supraphon.

LA DISCOTECA C.A.—Apartada 7811, Nueva Granada—CARACAS
(Avenida El Paseo No 19—Los Rosales—Caracas)
Phone: 61-0237, 61-0238, 61-2017
Cable: LADISCOTECA CARACAS
Pres.: Mr. Wilhelm Ricken
Labels (domestic): Erna, Ultra
Labels (others): CBS, Command, Dot, Hispavox, Musart, Plaza, Zeida.

RCA DE VENEZUELA C.A.—Apartado del Este 11275—CARACAS
(Avenida Francisco de Miranda—Edificio Galerías Miranda—Caracas)
Phone: 33-9721
Cable: RADIOINTER CARACAS
Pres.: Mr. C. E. Treulle
Labels (domestic): RCA Victor
Labels (others): RCA Camden, RCA Victorla

ROBERTO GOMEZ RUEDA & SEGURA S.R.L.—Miranda a Madero—Edificio Caracas—Local B—CARACAS
Phone: 41-5291
Cable: ROBEGOMER CARACAS
Pres.: Mr. Roberto Gomez Rueda
Man. Dir.: Mr. Antonio J. Segura
Labels (domestic): Robegomer
Labels (others): Carrizal, Fuentes.

RONDE DE VENEZUELA S.A.—Apartado 4766—CARACAS
(Venado a Piedra, Edificio Moliterno, Local I—Caracas)
Phone: 41-2578
Cable: RONDESA CARACAS
Pres.: Mr. Stanley W. Steinhaus
Labels (domestic): Mara, Ronde,
Labels (others): Belart, Bel Air, Chant du Monde, Clan, Design, Ele, Embassy, Everest, Fonopolis, King (Japan), Lisboa, Oriole, Pathé, Reprise, Ri-Fi, Teledisc.

SIEMENS VENEZOLANA S.A.—Apartado 3616—CARACAS
(Avenida Principal de Los Ruices—Caracas)
Phone: 34-8531
Cable: SIEMENS CARACAS
Vice President: Mr. Wolfgang Seelig
Labels (domestic): Philips, Polydor
Labels (others): A8C-Paramount, Archiv-Produktion, Deutsche Grammophon, Fontana, Heliodor, Impulse, Mercury, M.G.M., Riverside, Verve, Wing.

VENEZOLANA DE GRABACIONES C. A.—Apartado No 8569—Quinta Crespo—CARACAS
(Rio a Puente Soublette—Local No. 1—Caracas)
Phone: 42-7330, 41-6367
Cable: CAVEGA CARACAS
Pres.: Dr. Julio Brillembourg
Labels (domestic): Sam, Vega
Labels (others): Decca

PRESSING PLANTS

FAVEDICA (FABRICA VENEZOLANA DE DISCOS C.A.)—Apartado 3402—CARACAS
(Cuarta Calle—Ciudad Industrial Carapa—Caracas)
Phone: 24 178, 23 867
Cable: FAVEDICA CARACAS
Dir. Gen.: Mr. Manuel Garcia

GRABACIONES ANTOR S.A.—Calle Baruta No 60—El Valle—CARACAS
Phone: 69-2546
Cable: GRANANTOR CARACAS
Pres.: Mr. Antor Antor

VIETNAM

(Democratic Republic of)

EXPORT & IMPORT

XUNHASABA—32 Hai Ba Trung Street—HANOI
Phone: 4067
Cable: XUNHASABA HANOI
Only organization to be contacted in questions of export or import of ready-made cultural goods (records and sheet music editions).

RECORD MFRS

STATE CORPORATION FOR EXPORT & IMPORT OF CULTURAL COMMODITIES—Hai Ba Trung Street 32—HANOI
Phone: 4067
Cable: XUNHASABA HANOI
Labels (domestic): Dihavina
Labels (others): Amiga, Eterna (G.D.R.), Balkanton (Bulgaria), Electrecord (Rumania), M.K. (USSR), Muza (Poland), Qualiton (Hungary), Supraphon (Czechoslovakia).

VIETNAM

MUSIC PUBLISHERS

TINH HOA MIEN NAM—P.O. Box 510—SAIGON
(51 Tran-Hung-Dao—Saigon)
Phone: 23-595
Cable: TIHOMINA SAIGON
Pres.: Mr. Le Mong Bao

RECORD MFRS

ALPHA RADIO—P.O. Box 350—SAIGON
(157 Duong Tu-Do—Saigon)
Phone: 22-118
Cable: ALPHARAD SAIGON
Pres.: Mr. Thai Thuc Nha
Labels (domestic): Hoanh-Son, Huong-Son, Kim Thanh, Song Huong, Thu-Do, Van-Duc, Viet Nam, Viet-Thanh
Labels (others): Audio Fidelity, Barclay, Brunswick, Capitol, CBS, Columbia, Command, Decca, Deutsche Grammophon, Dot, Grand Award, His Master's Voice, Liberty, London, MGM, Odeon, Parlophone, Pathé, Polydor, RCA Camden, RCA Victor, Stateside, United Artists.

HONG-HOA—215, Khong-Tu Street—CHOLON
Phone: 87.733
Pres.: Mr. Chau-van-Choi
Labels (domestic): Honghoa, Lamson, Nhacthanh

XU'O'NG TO-VAN-NGOC—P.O. Box 769—SAIGON
(49, rue Pasteur—Saigon)
Pres.: Mr. To van Ngoc
Labels (domestic): Doi-Moi, Thanh-Minh, Thanh-Nga

PRESSING PLANTS

ASIA DISQUES—626, Ham-Tu Quay—CHOLON
Phone: 22098
Cable: ASIA DISQUES CHOLON
Pres.: Mr. Ngo-van-Duc

WESTERN SAMOA

RECORD MFRS

WM. BRECKWOLDT & CO.—P.O. Box 47—APIA
(Beach Road—Apia)
Phone: 343
Cable: BREWO APIA
Mgr.: Mr. Martin Funck
Labels (others): Archiv-Produktion, Deutsche Grammophon, Polydor, etc.

YUGOSLAVIA

COLLECTING SOCIETIES

Z.A.M.P.—ZAVOD ZA ZASTITU AUTORSKIH MALIH PRAVA—P.O. Box 631—BELGRADE
(Misarska 12-14—Belgrade)
Phone: 38-765, 34-771
Cable: ZAMP CENTRALA BELGRADE
Pres.: Mr. Mihailo Kilibarda
Mechanical Licenses & Performing Rights Society

MUSIC PUBLISHERS

METRONOM—EDITIONS MUSICALES—Ruzelitova, 19—BELGRADE
Phone: 41.700
Cable: METRONOM BELGRADE
Administrator: Mr. Dragomir Ristic

ZABAVNE MELODIJE—EDITIONS MUSICALES DE L'ASSOCIATION DES COMPOSITEURS DE LA MUSIQUE LEGERE DE CROATIE—Radiceva 20—ZAGREB
Phone: 37.607
Cable: ZABAVNE MELODIJE ZAGREB
Pres.: Maestro Ferdo Pomykalo

RECORD MFR

JUGOTON-RECORDS—P.O. Box Dubrava-4—ZAGREB
(Pokupska Street—Dubrava—Zagreb)
Phone: 44.338, 44.341, 44.522, 44.729
Cable: JUGOTON ZAGREB
Dir. Gen.: Mr. Slavko Kopun
Labels (domestic): Jugoton
Labels (others): Amadeo, Brunswick, Cameo/Parkway, Carisch, Clan, Copacabana, Coral, Decca, Durium, Elite, Fonit, Italdisc, Juke-Box, M.G.M., Moon-glow, Polydor, Primory, RCA Camden, RCA Victor, Ricordi, Ri-Fi, Ronnex-Teeny, Sabrina, Telefunken, Triola, 20th Century Fox, United Artists, Verve, Vogue.



GERMANY



MEXICO

You could never tell that Germany is "beat" crazy by checking out the top 10 charts. 9 of the 12 songs listed (2 records are double sided hits) are German compositions and the other 2 include a soft ballad instrumental and a shuffle beat ballad. Breaking down the top 10 is an easy thing. "Il Silenzio" by Nini Rosso is a slow moving instrumental ballad making chart headings all over Europe. "Mit 17" from Peggy March is a slow ballad which won the German Song Festival. "I Could Easily Fall In Love With You" in German by Cliff Richard reminds one of "Lucky Lips" of a few seasons ago, while "Darling Goodnight" is a western ballad. "The 5th Wheel On The Wagon" by Siw Malmkvist is a sprightly happy tune but far from beat music. "The Birds And The Bees" b/w "Have You Forgotten Everything" is a combination slow beat and ballad recording by teener Drafi Deutscher which comes closest to the beat sound. Another happy festival number "Don't Talk About It" by Norwegian Wencke Myhre is also far from the beat type as is "Knives, Forks, etc." by Vicky. The next tunes, "Blond Hair" and "A Sparrow" by Dorte, are also happy, festival type tunes, while "Santo Domingo" is a slow ballad written especially for Wanda Jackson. 6 of the top 10 are female artists with only one, Vicky, coming from Germany, and she's the daughter of Greek artist Leo Leandros. Malmkvist is from Sweden, Dorte from Holland, Peggy March from the U.S., as is Wanda Jackson, and Wencke Myhre, as we mentioned, from Norway. 3 male artists, Cliff Richard with 2 German stars, Ronny and Drafi, and an Italian trumpet star, Nini Rosso, finish off the top 10. The strange reason for the popularity of beat music, but the lack of placement in the top 10 is that the top 10 is basically calculated from juke box sales which do not reflect the heavy beat trend prevalent in the big cities of Germany. Lack of knowledge of the English language combined with lack of knowledge of new dances and the basic old fashioned tastes of the country people lead to strong sales of German language material of a non-beat nature. However, the Beatles, Rolling Stones, Kinks, etc. continue to rack up impressive sales figures and a basically good overall sales figure on each and every release, to place this type of music among the most popular in the country. So, don't let the charts fool you. Beat is here to stay.

Polydor reports that Peter Alexander is heading for an American tour and film. Other Polydor stars Lolita, Martin Lauer and Ivo Robic are also headed for the U.S. and Canada between Sept. 18 and Oct. 10.

Elite Special had a visit from Ernest Pollak from Erpol Music in Montreal, who represents the label in Canada, and W. Brandsteder and Mr. Beutler of Inelco Holland, who represents Elite Special there. The label has released a new single, "Farewell My Dear," by Toni Sandler of Austria, now performing in N.Y., and "Serenade For My Love," with the Heinz Kiessling Orchestra.

Rolf Budde reports that the German song "Summerwind," has three top notch hit recordings, by Perry Como, Roger Williams and Wayne Newton, and is moving swiftly in the Cash Box hit charts. On the local picture, Budde is getting action on "Mr. Tambourine Man," with a top notch German waxing also in the offing. The new Beatles hit, "Help," has also been released here, and the new picture by the same name is due soon. His promotion man, Peter Rebhuhn, is now on the road pushing the new summer hits.

Hans Gerig is very proud that the top 3 hits listed in the teen magazine, Bravo, all come from his publishing company, including "Rock and Roll Music" from the Beatles, "The Last Time" from the Rolling Stones and "Mit 17 Hat Man Noch Traeume" from Peggy March. The Peggy March smash hit is in every hit parade in Germany, and now holds down the number 2 slot in the Cash Box Germany top 10.

D.G.G. will open the fall season with the new Masterworks, in De Luxe Editions series. The 3 packages, each containing 8 LP's, will be priced at \$29.50 for the Chopin package, the Schubert chamber music package will retail at \$32.00 and a new complete album of "The Music Flute" from Mozart will retail at \$12.50. The normal price for the packages here would be \$46.00, \$49.00 and \$18.75 respectively. The low price is due to the tremendous advance orders from the 14 European countries where the packages are being released simultaneously. A special sample LP of music from Chopin and Schubert with works not contained in the above mentioned packages, is being offered for \$1.25 retail to awake interest in the series.

Teldec announced that 3 of the top jazz prizes from the German Jazz Federation have been awarded to the firm's product, including "Best Release"—Coleman Hawkins, with old and more recent recordings in his "Body And Soul" album, "Best Big Band Swing LP"—Duke Ellington's jazz version of "Mary Poppins" on Reprise, and "Top Gospel Recording" went to the LP, "The Davis Sisters Sing."

CBS is getting great action on its LP "Hits Of The World," including top U.S. and German, as well as Italian recordings of stars like Bobby Solo, Ray Conniff, The Supremes and many others.

Klaus Teubig of Edition Esplanade wrote to tell us that the firm has "hot" summer days with top new recordings by Freddy, Lolita, Jo Roland and Renate & Werner Leismann. The firm has also issued 2 new lyric books from Freddy tunes which are racking up top sales.

Philips Records is giving top promotion to Horst Jankowski with his new waxing which is beginning to move in the U.S. The firm also reports that the Blue Diamonds received a Gold record in Spain for their waxing of "Ramona." Philips has taken over distribution of the Amadeo label for Germany. The repertoire includes top classical works and the Vanguard folk catalog. The Austrian firm formerly distributed themselves, but will now be exclusively handled by the Philips distribution. That's it for this week in Germany.

Mexico's Best Sellers

- 1 Crema Batida (Whipped Cream)—Herb Alpert (Tizoc)—Mayté (RCA)—Julian Bert (Orfeon)—Cliff Mendoza (Musart)—Chuck Anderson (CBS)—Pete Fountain (Coral)—(Emmi)
- 2 Bule Bule (Woolly Bully)—Sam The Sham (MGM)—Los Rockin Devils (Orfeon)—Luis Moya (Musart)
- 3 Sombras—Javier Solis (CBS)—Alberto Vázquez (Musart) Lena y Lola (Musart)—Los Tres Reyes (Orfeon)—(Emmi)
- 4 Sigamos Pecando—Los Diamantes (RCA)—Lena y Lola (Musart)—Hermanos Carrión (Orfeon)—Hnos Arriagada (Musart)—(Emmi)
- 5 Leccion De Besos (Letkis)—Julian Bert (Orfeon)
- 6 Lanza Tus Penas Al Viento (Cast Your Fate To The Wind)—Sonidos Orquestales (Gamma)
- 7 El Toro Y La Luna—Joselito (RCA)—Lola Beltrán (Peerless)—Salvador Escudero (Musart)
- 8 Por Eso Estamos Como Estamos—Los Apson Boys (Peerless)
- 9 Tiburo A La Vista—Mike Laurie (Musart)
- 10 Jugo De Palabras—Olivia Molina (Peerless)

The musicians union is still not getting along with the record manufacturers here and that is the problem because nobody has recorded for a month. It seems that this week everything will be in order again and that new record production will begin immediately.

From Spain we have received wonderful news about the Mexican duet Los Yorsys, who are having a complete success in their performances at Florida Park and on TV. Los Yorsys will also prepare one or more pictures and it seems that they will remain a long time in that country. Hispa Vox label is interested in cutting new Yorsys records with the permission of Musart, the Mexican label on which this duet is exclusive.

We also have received post cards from Angélica María and Manolo Muñoz, two other Mexican artists who are working in that country and who as a coincidence are also from the Musart artistic catalogue.

A border group commanded by Sam the Sham and the Pharaohs are hitting strong in town with his MGM hit "Woolly Bully," which is occupying one of the high places on the Mexican charts.

Finally after a long time, Enrique Guzmán performed on a radio station and in a TV musical series. Enrique announced his new album on CBS which is supposed to appear on the market in a few days. Enrique is preparing special songs written for him to make his debut singing in English for Columbia Records in the United States.

Gamma Records released two of the newest albums recorded by Frank Sinatra on Reprise. The first one is "Sinatra-Basie" Vol. II. The second is "Softly As I Love You." There are a lot of new releases on Reprise and Warner Bros. which we will announce in the next column.

Capitol de México, S.A. announces new changes in its executive staff: as promotion and advertising manager is Rene Flores and in the A&R department is Rafael de Paz, Sergio Guerrero and Nacho Méndez. By the first of the month will appear the first releases on this label.

Sergio Corona, Marco Antonio Muñoz, Daniel Riobobos and Antonio Prieto will fly shortly to Spain where all of them have good contracts to perform. And from Spain Silvia Pinal recently arrived here.

Alberto de Luque, an artist from Uruguay and who has spent most of his life in Europe, especially in Germany, is now in México performing in a theater and on TV. Dusa released on the Polydor label his latest album on which he includes songs like "Tabu," "Una Noche Así," "Cielo Rojo," "Mexico," "Martha," "Tokyo Blues," "He Sabido Que Te Amaba" and others.

RCA Victor, which some time ago enlarged its studio "A", now has a new one named "B". The company said that in no less than three weeks they will be able to do some new recording. If the musicians strike is finished before, RCA will have to record in other record companies so they won't lose any time.

American star Frankie Avalon is now in México promoting his picture which appears in the American International movie festival and at the same time is appearing in some TV shows participating in interviews.

Under the Eco label appeared an album recorded by South American vocal group Los 4 Brillantes who sing in this album "Te dejé Sin Pensar," "Quiero Tomar Tu Mano," "Vestida De Novia," "Tu Nos Estás," "Dame Pronto Una Oportunidad," "Vuelve A Mi Barquita," "Nada Mas Un Recuerdo," "Una Sola Vez," "Quiero Saber Por Que" and "La Bamba." These recordings were made in Peru.

Lorenza Lori, the beautiful Italian blonde, cut at Peerless Records on e.p. with the songs like "Señor, Señor," "El Futbol," "De Rodillas A Ti," etc. . . . Lorenza will settle in Mexico.

Germany's Best Sellers

This Week	Last Week	Weeks On Chart	Title
1	1	6	Il Silenzio—Nini Rosso—Hansa/Ariola—Intro/P. Meisel
2	2	2	*Mit 17 Hat Man Noch Traemue (At 17, You Still Have Dreams)—Peggy March—RCA Victor—Hans Gerig Music
3	3	6	Es War Keine So Wunderbar Wie Du (I Could Easily Fall In Love With You)—Cliff Richard—Columbia—Aberbach Music
4	4	6	*Darling Goodnight—Ronny—Telefunken—Edition Marbot
5	5	2	*Das 5 Rad Am Wagen (The Fifth Wheel On The Wagon)—Siw Malmkvist—Metronome—Intro/P. Meisel & Rolf Budde Music
6	6	10	§Heute Male Ich Dein Bild, Cindy Lou (The Birds And The Bees) & Hast Du Alles Vergessen (Have You Forgotten Everything)—Drafi Deutscher—Decca—Intro/P. Meisel
7	7	2	*Sprich Nicht Draeber (Don't Talk About It)—Wencke Myhre—Polydor—Minerva Music
8	8	6	*Messer, Gabel, Schere, Licht (Knives, Forks, Scissors, Light)—Vicky—Philips—Ralf Arnie Music
9	9	2	*§Blondes Haar Am Paletot (Blond Hair On Your Jacket)—Minerva Music & Eine Schwalbe Macht Noch Keinen Sommer (One Sparrow Doesn't Make A Summer)—Melodie Der Welt/Michel—Dorte—Philips
10	10	12	*Santo Domingo—Wanda Jackson—Capitol—Hans Gerig Music

*Original German Copyright.
§Double Sided Hit.

Brenda In Japan



During her recent tour of Japan, Brenda Lee took the occasion to record a pair of sides in Japanese for Polydor. Shown at the session, the lark belts away at "Walk Away" and "Beautiful Dreamer" for the division of Decca Records. Her latest hit in the United States is "Too Many Rivers," currently in the number 27 slot.



ARGENTINA



CANADA

Last week we had the pleasure of having a chat with **Juan Truden** and **Douglas Taylor**, CBS' toppers just returning from the Columbia Miami Convention. Both reported being happy with the results of the gathering and having several new artists who could be promoted in Argentina, along with other already established names who will receive additional push from now on. Columbia's "Grow Power" policy, as it applies to this market, will be explained to dealers, following CBS' idea of building one image throughout the world.

As it was reported last year, the next meeting of the Latin American Federation of Record Producers will take place at the beginning of Oct. in Buenos Aires. Since the last gathering was a complete success, it is expected that this one will also serve to unify policies of record companies in all Latin American countries regarding common problems. It is also expected that outside record producers will also be present, since the presence of the most important diskeries at the same time will also mean big business for them.

Plenty of work at Julio Korn with the inking of "Quello Sbagliatto," the Bobby Solo "Un Disco per L'Estate" chartbuster. The pubbery has already prepared Spanish lyrics to be used by **Ricardo Rey** (Disc Jockey) for his recording. On the other hand, CBS will market the original Solo recording, which is expected to follow the success of his previous renderings. Other interesting JK items are "La Nuit," the Adamo tune which will be cut by **Juan Ramon** (RCA) and **Ricardo Rey** (Disc Jockey), while Odeon prepares the release of the original.

A big cash flow is expected at Odeon with the first album by the Shakers, the first local teen group to hit the market in some time. The album contains their best singles, like "Rompan Todo" and "Searchin'," coupled with their own tunes, like "Dance Shake, Baby," "Don't Ask Me Love" and others. There is also a new double 33 by **Claudia**, and an interesting album recorded by **Dorita and Pepe**, British artists who visited this country some time ago.

Music Hall is also seeking the jackpot, with a two-record set in this case. It is a new release under the "Difusion Musical" series, with the well remembered **John Hammond** Carnegie Hall Concert, "Spirituals To Swing." The box is priced at 890 pesos (\$5.20) while regular price should be around 1500 pesos (\$8.70). Since there is a lack of such recordings on the market, it may well be imagined that sales figures will be good. Other news concerns Compact 33's by **Rodolfo Zapata** and folk group **Los Chanas**, and, of course, the new "Barbaro" promotional album. **Luis Calvo**, the diskery's VP, has recently held chats with **Fermata** Publisher's **Mauricio Brenner**, from which a tight cooperation between both organizations will result, to bring prompter recordings of international and local tunes.

RCA is working hard on the promotion of Uruguayan group **Los Iracundos**, who have done several recordings during the past weeks, including hit tunes like "Se Piangi, Se Ridi" and standards like "The Man with the Golden Arm." The new single by **Palito Ortega**, "Cancion del Jacaranda" and "Señor Apache," is selling well, bringing the artist once more to the charts, where he has been for the past 24 months. This single is intended to reach the kiddie market, with tunes penned by the same Ortega and **Maria Elena Walsh**.

Phonogram's Promotion chief, **Landajo**, is very happy with the success of **France Gall's** "Poupee de Cire, Poupee de Son," which, after a strong air play campaign, has been selling very well, and is already in the charts. Phonogram now has a strong promo organization and plans to battle hard in the singles field. From the same diskery comes an EP by Brazilian group **Los Cariocas**.

Hugo Celano of Sprint Music infos that his company is representing the rights of "E Innamorato Poverissimo," written by **Paolo Mosca**, and "Yo Soy Joven," whose English version has been recorded by **Leslie Gore**. The same tune, in Italian, has been cut by **Isabella Gianetti** and several local versions are expected soon.

Jose Bragato of Ala-Nicky sends word about an EP by **Leo Lipesker's** orchestra, to be released soon. There is also another one, by the same musician and **Pocho Gatti**, tagged "Milongas." **Luis Ordoñez'** first waxings for this label are also due.

More about CBS: the diskery will release a single with "Coplas del Payador Perseguido," written by **Yupanqui** and cut by **Jorge Cafrune**, one of the top folk artists of the moment. Cafrune has just finished the recording of his fourth album.

News from **Fermata**: **Claudio** (Odeon Pops) has recorded the Spanish version of "Crying in the Chapel;" **Atilio Marinelli**, for the same label, has "Huyo de Ti," while **Los Cinco Latinos** (Music Hall) have coupled "Que C'est Triste Venise" to "Momele." **Atilio Cabestri**, also for MH, will cut "Sangre Ecuatoriana" and "El Sombrero," and **Siro San Roman**, Solo Nata Per Te." **Producciones Fermata** is releasing an album tagged "Bossa En el Paramount" and singles by **Luigi Tenco** ("Tu no has Entendido Nada" and "Balada del Amor") and **Elly Nery** ("Que C'est Triste Venise" and "En Casa de Irene")

Ricardo Castelblanco of Edami infos hard work on "Cumbia Que Vas de Ronda," cut by **Niko Estrada** (Odeon). **Los Martinicos** (Music Hall), **Los Tres Trombones** (RCA) and Mexican star **Carmen Rivero** (CBS). The **Cuarteto Imperial** (CBS) has cut "No Me Olvides Nunca," written by Mexican composer **Federico Baena**, who won the First Prize at the 1962 Mexican Song Fest with "Ay Cariño."

Argentine Diskery Convention



FERMATA FESTIVITIES—Messrs. Philip N. Brodie, general manager of Odeon (Electric & Musical Industries) and M. S. Brenner, general manager of Fermata Records, are shown presiding at the dinner which concluded the diskery's convention. With them at the dais are (left to right) Dr. Carlos G. Menica, Fermata's legal adviser; Enrique O. Rosso, Odeon commercial manager; and sales manager Roberto Abatte.

Jack London has switched to RCA Victor in Canada. His first pairing for the label is "Don't Ever Change" b/w "Misery And Me". The postal strike here has played havoc with record releases. Arc didn't take any chance of the strike fouling up their distribution on **Terry Black's** revival of the **Sam Cooke's** whilebacker, "Only Sixteen". The record was air-expressed to key jocks by **Arc's Bill Gilliland**. He reports that initial reaction across Canada is fabulous. Moreover big things are expected stateside as a result of the artist's "Shindig" P.A.'s. **Corrine Burke** at Phonodisc in Winnipeg has a whole raft of red hot singles. "The Same Old Song" by the **Four Tops**, the latest outings by the **Supremes** and **James Brown** are big air action singles in Winnipeg, and at the Canadian Lakehead, with sure sales as soon as the firm can get product on the market. Now that the strike is over, for the most part, dealers are readying for concentrated action on all of these red hot Phonodisc items that **Corrine** has happening. **Ray Nickel** reports that recent P.A.'s in Saskatoon have spotlighted **Tom Northcott** and the **Vancouver Playboys**, and on another occasion, **Buddy Knox**. In so far as big records are concerned, **Ray** reports that the latest item by **David Clayton Thomas**, "Take Me Back" has been a big winner on the CKOM battle. **Danny Roman** reports that the chanter and the **Shays** will be heading into New York's **Peppermint Lounge** in September. Both the **Thomas** group and the **Paupers** have been appearing regularly at the C.N.E.'s "Under 21 Club" sponsored by a leading soft drink firm. The **Paupers** also were set for a P.A. at the **Mariposa Folk Festival**. **Carl C. Schmidt**, Fonorama topper, drops a line from New York. He has just completed a session there with **Michel** and the **French Canadiens** for his **Danco** Label. He has high hopes for the outing. **Morty Wax** indicates that good action can be expected on a **Sparton** outing in Canada by **Con Pierson** called, "Somewhere Down The Line". It originates with **Ford Records** in the U.S. **Carl Schmidt** also notes that he's in search of a good, girl vocal group. He can guarantee year round work, plus a recording contract for the successful group. Top rated, teen-type, deejay **Bob Gibbons** exits **CHSJ**, St. John to assume new duties at **CJCA**, Edmonton. **Andy Arnott** is new host of the all night show on **Lakehead's CKPR**.

Note: Anyone headed for sunny California anytime between Sept. 20th, '65, and January 4, 1966. **Walter E. Hurst** teacher of a course entitled, "The Music Industry—Its Structure and Economy," at the University of California at Los Angeles, has expressed hope in a letter to this column that some representative of the music industry in Canada who may happen to be in the vicinity during the period mentioned would address his class on the subject of the music industry in Canada. The students taking this extension course at U.C.L.A. learn about the practical aspects of music publishing, record production and distribution, and related fields. **Hurst** may be contacted by mail at 6365 Selma Avenue, Hollywood 28, California, Hollywood 9 7200. **Reg Ayres** reports from Winnipeg that **Chad Allan** and the **Expressions** were in their hometown for a few fleeting hours to do a P.A., then they went on to Edmonton, as they continued their tour of the U.S. **Reg** indicates that a follow up single to "Tossin' And Turnin'" will be released shortly. **Reg** reports that "You Were On My Mind" by **We Five** is far and away his best selling single. Big air play action in Winnipeg, the Canadian Lakehead and most other centres in his territory is responsible for the good quality outing doing so well. **Reg** points out that fan clubs for **Herman's Hermits** can contact area headquarters; **Pres. Margie Ross**, 860 Garwood Ave., Winnipeg, 9, and for **Chad Allan** and **The Expressions**—**Pres. Jane Kimak**, 513 Newman St., Winnipeg 10. **Al Mair** has rave notices for the new **Leroy Van Dyke** single, his debut on **Warner Bros.** "My Baby Digs Slot Car Races" by the **Revells** has been lifted from a **Reprise** album and released in Canada only as a single. It follows concentrated action on the item after battle exposure on **CHUM**, Toronto. It now appears as if "Liar Liar" by the **Castaways** on **Apex** will finally break the chart barrier. It's set to appear on the Aug. 14 edition of the "Fab '58" at **Lakehead's CKPR**, following big action in the neighbouring **Duluth, Minneapolis** areas.

Argentina's Best Sellers

This Week	Last Week	Title	Artist
1	1	Ho Capito Que Ti Amo	(Radio Record-Fermata) Luigi Tenco (Fermata); Jose Antonio (Microfon); Wilma Goich (CBS); Claudio Fabre (Music Hall) Claudio (Odeon Pops)
2	4	Que C'est Triste Venise	(Aznavor-Fermata) Charles Aznavour (Disc Jockey); Juan Ramon (RCA); Claudia (Odeon Pops); Los Cinco Latinos (Music Hall); Elly Nery (Fermata)
3	2	Cominciamo Ad Amarci	(Leonardi-Fermata) John Foster (Fermata); Los Cinco Latinos (Music Hall); Jose Antonio (Microfon)
4	6	Se Piangi, Se Ridi	(Melograf) Bobby Solo (CBS); Los Iracundos (RCA) Mina (Fermata); Ricardo Rey (Disc Jockey)
6	10	*Caramelo Santo	(Melograf) Cuarteto Imperial (CBS)
6	3	Io Che Non Vivo Senza Te	(Accordo-Fermata) Juan Ramon (RCA); Pino Donaggio, Claudia (Odeon Pops); Tony Dallara (Fermata); Ricardo Rey (Disc Jockey); Ricardo Roda (CBS); Alberto Ayes (CR); Dany Martin (Philips); Siro San Roman (Music Hall)
7	9	*Los Domingos	(Korn) Los Cinco del Ritmo (Microfon)
8	5	Calhambeque	(Korn) Piero (Philips); Roberto Carlos (CBS); Los Iracundos (RCA); Los Bucaneros (Music Hall)
9	12	*Sr Apache/Cancion Del Jacaranda	(Korn) Palito Ortega (RCA)
10	13	Keep Searchin'	The Shakers, Richard Anthony (Odeon Pops)
11	7	*La Mañana	(Korn) Horacio Ascheri (Music Hall)
12	18	Christina	(Melograf) Bobby Solo (CBS)
13	—	Poupee De Cire, Poupee De Son	(Korn) France Gall (Philips); Juan Ramon (RCA); Leo Dan (CBS); Claudia (Odeon Pops); Los Pick Ups (Music Hall)
14	16	Ticket To Ride	(Northern-Fermata) The Beatles (Odeon Pops)
15	—	Solo Quiero Estar Contigo	(A Present Tu Peux T'en Aller) (Korn) Juan Ramon (RCA); Richard Anthony (Odeon Pops)
16	8	*Rompan Todo	(Fermata) The Shakers (Odeon Pops)
17	17	*Calor	(Korn) Palito Ortega (RCA)
18	—	*No Quisiera Quererte	(Lagos) Horacio Guarany (Philips)
19	15	No Olvides Que El Es Mio	(Korn)/Tomame en Tus Brazos Sylvie Vartan (RCA); Dave Clark Five (Odeon Pops)
19	11	Oh Pretty Woman	(Korn) Sylvie Vartan (RCA); Roy Orbison (London)
20	14	*My Linda Betty	(Melograf) Cuarteto Imperial (CBS)
20	—	*La Casita Blanca	(Korn) Los Wwanco (Odeon Pops)
20	—	Eight Days A Week	(Northern-Fermata) The Beatles (Odeon Pops)
			*Local

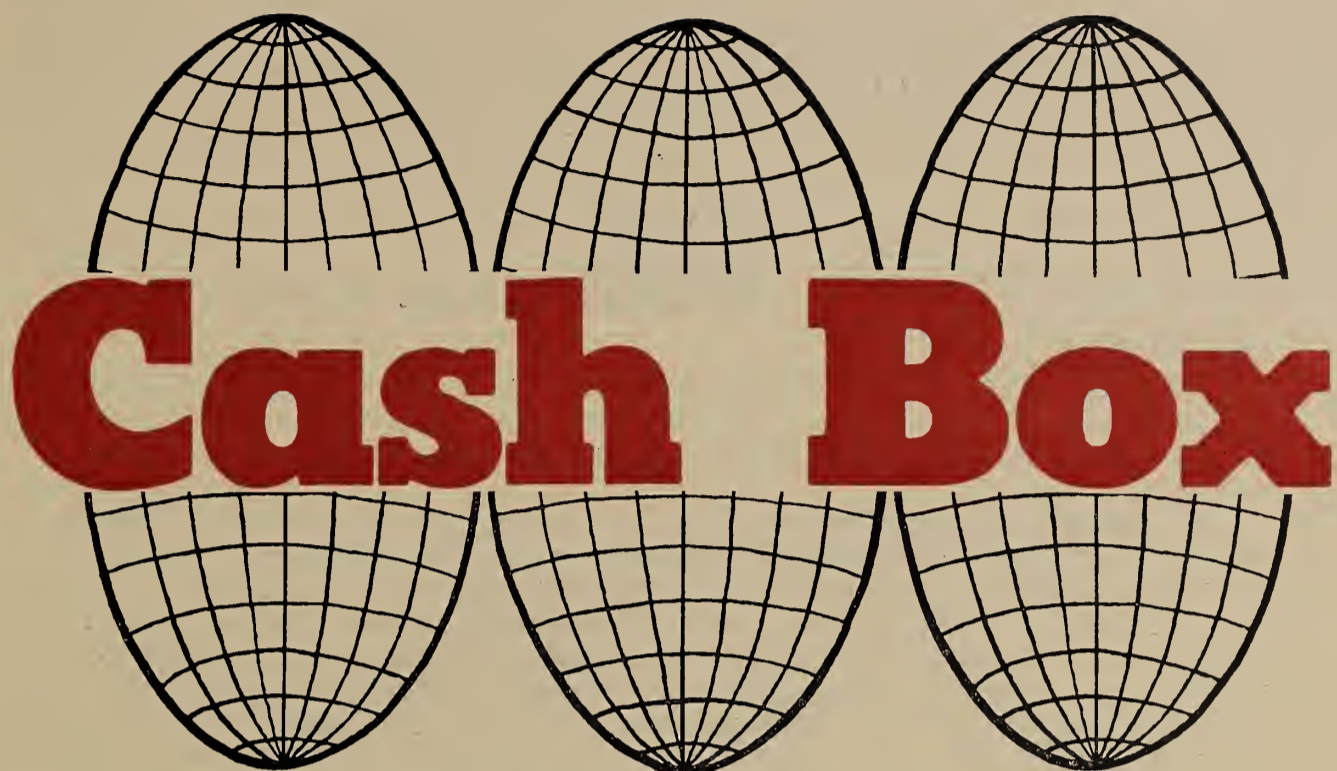

ANNUAL

World Wide

**COIN MACHINE
and VENDING**

DIRECTORY

1965-1966

23rd Anniversary Edition

from the desk of...

JOE ORLECK
OF



August 14, 1965

Dear Friends:

With the publication of our 23rd Annual Coin Machine & Vending Directory, it is gratifying to know that the past twelve months have seen the attainment of industry goals by the people who comprise this fascinating industry.

Recording the events of our fiscal year has, for the most part, always been an exhilarating experience. Oftentimes, it has occurred to us that the ingenuity which generates much of the new innovation could only have emanated from the minds of coin machine and vending industry people.

During the past twelve months this industry has witnessed the introduction of radically new merchandising techniques in music and equally radically new proposals for solving a silver-coinage dilemma.

Legislators have ruled favorably on vital amusement machine issues in even the largest State, while other minds telescoped the unique success of a billiard game to greater heights in the home field. Even the audio-visual concept of coin-operated entertainment, launched three years ago, continues to hold interesting potential for the more persistent individuals who see the germ of further innovation on a basic idea.

Foresight and versatility are equally admirable characteristics of people in this coin-operated field. Diversification of music and amusement operators into vending, and the move into music and amusement by vending firms is ample proof of the ability of operators to act as modern businessmen. This trend continues and will become more established as present routes develop.

Versatile legal instruments such as installation agreements have shored up frailties in operator-location relationships. Long sought after solutions to problems as severe as a shortage of technicians came to light as operator groups planned programs in conjunction with city officials.

There are more local Associations serving operators than ever before. The nation's Capitol and dozens of State legislatures now recognize the legitimacy of an industry whose voice was not always heard. Much has been accomplished by many during the last twelve months and the outlook is clear and sure.

Each Cash Box Directory has reflected the Companies and the Products which are the tools of an industry's personnel. We present this 23rd Directory as yet another tool to be used by those who seek continued success, and we thank the members of the coin machine and vending industry around the world for making such a Directory possible.

A handwritten signature in black ink that reads 'Joe Orleck'. The signature is written in a cursive, flowing style.

President and Publisher

ANALYSIS OF THE ANNUAL COIN MACHINE & VENDING EXPORT VOLUME REPORT 1964

GENERAL

The four quarterly export report finals for phonos, amusement and vending, if placed on a graph chart, would read like an electronic ping-pong match. Starting with the first three months, smiles broadened as the volume reached almost \$13 million. The second quarter straightened the smiles somewhat when just over \$12 million was recorded. But the third quarter, the one which reflected the straight-jacket credit conditions of France, the changing scene in Belgium, and other inequitable rulings, all of which limited export shipments, didn't even touch the \$9 million mark. By the year's end, the final quarter, which brought the record \$44 million annual figure into view, sales had climbed back to \$10.4 million. Brightest spot on the globe was Japan, which continues to shine. What the future will bring in France—and Italy, where as of March 25th no equipment was permitted—only time will tell. Here's the way the "types" of equipment broke down.

PHONOGRAPHS

Off \$8 million in world total volume, music picked up a half million dollars in North America thanks to Canada's drive and development. So. America managed to even-off in the face of trouble in Argentina. Peru did nicely in units but dollar volume remained constant. Europe dipped \$2 million largely because of Belgium and Switzerland where it is reported European made juke boxes which sell for around \$750 in domestic currency are making headway. The UK and West Germany, ever-true to the import cause, took more equipment than ever. Japan spoke for Asia with a resounding \$1.7 million volume and the boom is not near its peak, wherever the peak may be. Chicago, Grand Rapids and Tonawanda factories are enjoying a break-out in Japan, previously reported in a Cash Box editorial, and on-the-scene exporters such as R. H. Belam, look for boom-markets to continue here not only in music but games as well. Several of the new equipment distribs in Japan are also unusually large operators. The stage is set for continued expansion here. In Africa, music is shipped mostly to Kenya, and from there to outlying territories. But the figure is rather constant.

AMUSEMENTS

Imagine what the Amusements total would be if it were not for the problems in Europe. With a six-month flood of equipment going into France, for instance, the total figure would have been astronomical had it not been for restrictions imposed by the Government. Belgium can't make up its mind over bingos and pinball problems and Italy has completely rejected all amusements, even in clubs (March 25th notice). Italy registered almost \$2 million before the close-down. Switzerland fell off here too, with a \$300,000 drop for the year. England, bless her heart, bought almost \$4 million in amusements and games. The 15% import tax didn't mean a thing when it was passed before the year's end, and the 5% relaxing of this tariff bringing it to 10% won't mean anything either. Europe picked up \$2 1/2 million against '63 in spite of the legislative and credit restrictions. Japan bought 5,383 amusement machines in 1964. Some bright prospect! Kuwait continued to increase volume and the Philippines showed encouraging signs. Australia's economy and various rulings held the volume to \$200,000 but it was all welcome.

In African territories, Malagas led a group of one dozen countries, most of which represent good potential for the long-term pull.

By New Year's Eve 1964 the export market bought more than \$24 million in Amusements, more than half of the action. In spite of reported European-made pinball games and such, America was still taking more than a lion's share of amusements business through exports.

VENDING

This slow-growth area, for American-made equipment, picked up more than 25% with a \$1 million gain in '64. As usual, this figure represents only equipment (new and used) shipped from U.S. ports. The factories with European plants turning out machines for domestic use over there, would of course fatten this figure considerably.

Canada takes almost all of the No. American figure. So. America can't handle much of a business at this moment. Most of the gain was made in Europe where Spain led the rest, all of whom were evenly spread about neck and neck as far as total figures are concerned. Sweden and the UK are possible exceptions showing individual gains above the average. Japan dropped in vending, possibly because of increased factory production in the homeland. Africa's Un. of South Africa spurted for a \$53 thousand volume, after buying only 25 vendors in the whole of 1963.

SHIPPING
THE
FAR EAST
DAILY!



MANILA
TOKYO
HONGKONG
NAHA
BANGKOK
KUALA LUMPUR
SINGAPORE
AUSTRALIA
SAIGON
PORT SWETTENHAM

We specialize in shipping juke boxes and games to the Far East. May we serve YOU?

DUARTE INTERNATIONAL

835 East 31 St.
Los Angeles 11, Calif. U.S.A.

CABLE:
DUARTEX, Los Angeles

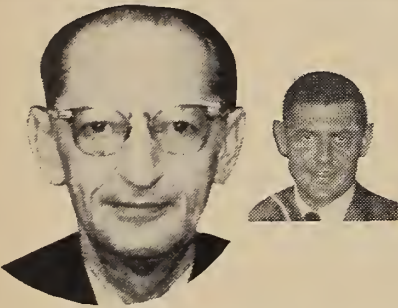

HYMIE & EDDIE ZORINSKY

Present the popular coin machine lines that make available to their operator friends the best money making potential:

**ROCK-OLA
GOTTLIEB
CHICAGO COIN
FISCHER**

**NOW AVAILABLE
ROCK-OLA'S**

★ GRAND PRIX II
★ STARLET
★ PRINCESS ROYAL
★ PHONETTE WALLBOX

Large stock of Used Music & Games on Hand

Call Us Today
We'll Tell You Why!
Phone: 341-1121

H.Z. Vending & Sales Company
1201-03-05-07 Douglas St.
Omaha, Nebr. Ph. 341-1121



PHONOGRAPHS

COUNTRY	1964 VOLUME (Jan.-Dec.)		1963 VOLUME (Jan.-Dec.)	
	Units	Dollars	Units	Dollars
NO. and CENTRAL AMERICA				
Bahamas	40	\$ 30,037	65	\$ 28,043
Barbados	—	—	—	—
Bermuda	14	5,245	2	500
British Honduras	16	5,269	10	7,892
Canada	1,513	1,147,346	1,603	1,014,281
Costa Rica	55	43,181	50	40,296
Dom. Rep.	540	138,219	567	154,672
El Salvador	5	4,383	26	15,724
Fr. West Indies	16	4,518	18	5,500
Greenland	—	—	—	—
Guatemala	3	2,534	7	5,808
Haiti	—	—	—	—
Honduras	56	12,324	6	5,309
Iceland	—	—	—	—
Jamaica	674	239,683	207	48,233
Lw Ww. Is.	14	12,337	14	4,758
Mexico	441	186,002	256	97,779
Neth. Antilles	9	6,763	24	14,818
Nicaragua	144	80,661	68	32,458
Panama	91	84,867	118	82,993
Trinidad	16	13,315	1	1,100
TOTAL	3,647	\$ 2,016,684	3,042	\$ 1,560,164

SOUTH AMERICA				
Argentina	16	\$ 10,247	48	\$ 10,339
Bolivia	—	—	—	—
Brazil	—	—	3	2,552
Br. Guiana	5	4,707	4	2,748
Chile	71	66,699	42	37,236
Colombia	2	1,320	—	—
Ecuador	24	18,870	—	—
Peru	154	77,124	152	110,311
Surinam	8	2,145	12	8,329
Uruguay	15	5,350	15	1,674
Venezuela	711	312,692	661	274,148
TOTAL	1,006	\$ 499,154	937	\$ 447,337

EUROPE				
Austria	91	\$ 37,915	164	\$ 122,847
Azores	—	—	—	—
Belgium	6,010	3,750,138	8,879	5,327,922
Cyprus	35	16,103	33	18,707
Denmark	56	45,536	29	24,239
Finland	68	54,450	505	392,312
France	751	580,180	590	468,740
Greece	916	277,660	408	119,575
Ireland	2	1,085	1	751
Italy	705	445,542	1,010	692,902
Malta	5	4,647	3	2,654
Netherlands	479	219,954	408	199,299
Norway	15	11,506	16	10,968
Portugal	2	2,000	2	2,302
Spain	—	—	—	—
Sweden	86	70,265	131	92,877
Switzerland	541	431,953	1,133	936,828
Trieste	—	—	—	—
Turkey	—	—	12	8,854
United Kingdom	1,554	875,500	1,277	647,651
West Germany	6,271	4,131,129	6,331	3,767,072
Yugoslavia	4	640	25	20,234
TOTAL	17,593	\$10,957,853	20,957	\$12,856,734

ASIA				
Arabia	4	\$ 2,846	—	—
Bahrain	4	2,880	—	—
Ceylon	1	770	—	—
Fed. Malaya	71	29,394	74	34,576
Hong Kong	48	26,455	17	11,091
India	—	—	—	—
Iran	—	—	4	1,160
Israel	—	—	—	—
Jordan	—	—	—	—
Japan	3,234	1,728,739	2,224	1,022,854
Korean Rep.	55	47,154	24	13,504
Kuwait	—	—	6	3,764
Lebanon	38	9,405	59	21,270
Nansei Is.	251	92,402	638	260,369
Pakistan	—	—	—	—
Philippine Rep.	264	112,481	260	65,971
Singapore	—	—	3	900
Syria	—	—	—	—
Taiwan	—	—	—	—
Thailand	21	11,257	—	—
Vietnam	—	—	2	1,326
TOTAL	3,991	\$ 2,063,783	3,311	\$ 1,436,785

AUSTRALIA				
Australia	126	\$ 48,794	157	\$ 67,066
New Zealand	23	2,532	32	4,235
T. Pac. Is.	8	2,398	—	—
Fr. Pac. Is.	—	—	6	3,957
TOTAL	157	\$ 53,724	195	\$ 75,258

AFRICA				
Algeria	—	\$ —	—	\$ —
Br. East Africa	—	—	10	2,740
Canary Is.	—	—	—	—
Egypt	—	—	—	—
Ethiopia	—	—	—	—
Fr. Somaliland	—	—	—	—
Gabon	—	—	—	—
Ghana	—	—	—	—
Kenya	46	14,283	17	3,515
Liberia	—	—	4	4,484
Libya	—	—	—	—
Malagas	—	—	—	—
Morocco	—	—	—	—
Mozambique	—	—	7	1,100
O. W. Africa	—	—	—	—
Rep. Congo	—	—	—	—
Rhod. NY	4	1,135	—	—
Som. Rep.	—	—	—	—
Tanzania	5	1,494	—	—
Tunisia	—	—	—	—
Union So. Africa	1	755	6	2,550
TOTAL	56	\$ 17,667	44	\$ 14,389

GRAND TOTAL 26,450 \$15,608,865 28,486 \$16,390,677

**1964 ANNUAL
EXPORT VOL**

AMUSEMENT M

COUNTRY	1964 VOLUME (Jan.-Dec.)	
	Units	Dollars
NO. and CENTRAL AMERICA		
Bahamas	125	\$ 22,064
Barbados	—	—
Bermuda	368	79,335
British Honduras	—	—
Canada	6,166	1,086,048
Costa Rica	2	400
Dom. Rep.	97	10,250
El Salvador	4	900
Fr. West Indies	—	—
Greenland	—	—
Guatemala	—	—
Haiti	—	—
Honduras	22	5,084
Iceland	—	—
Jamaica	30	9,960
Lw Ww. Is.	3	1,217
Mexico	720	54,522
Neth. Antilles	28	9,852
Nicaragua	9	2,655
Panama	180	40,803
Trinidad	37	11,513
TOTAL	7,791	\$ 1,334,603

SOUTH AMERICA		
Argentina	232	\$ 58,972
Bolivia	—	—
Brazil	—	—
Br. Guiana	—	—
Chile	43	10,040
Colombia	—	—
Ecuador	—	—
Peru	212	17,825
Surinam	6	2,325
Uruguay	55	2,040
Venezuela	824	330,648
TOTAL	1,372	\$ 421,850

EUROPE		
Austria	138	\$ 40,799
Azores	5	3,826
Belgium	4,128	1,462,160
Cyprus	132	51,519
Denmark	1,144	579,900
Finland	272	65,055
France	14,327	6,232,398
Greece	439	151,040
Ireland	30	14,253
Italy	5,274	1,922,552
Malta	—	—
Netherlands	563	122,244
Norway	1,071	434,283
Portugal	5	2,650
Spain	—	—
Sweden	1,111	540,826
Switzerland	4,440	1,322,920
Trieste	—	—
Turkey	78	62,317
United Kingdom	9,956	3,955,150
West Germany	9,744	3,060,324
Yugoslavia	—	—
TOTAL	53,006	\$20,066,033

ASIA		
Arabia	—	\$ —
Bahrain	—	—
Ceylon	—	—
Fed. Malaya	118	37,647
Hong Kong	14	3,781
India	—	—
Iran	2	1,400
Israel	—	—
Jordan	—	—
Japan	5,383	1,792,077
Korean Rep.	59	27,179
Kuwait	—	—
Lebanon	303	156,449
Nansei Is.	86	61,166
Pakistan	—	—
Philippine Rep.	113	64,535
Singapore	—	—
Syria	—	—
Taiwan	7	5,458
Thailand	4	950
Vietnam	24	16,241
TOTAL	6,113	\$ 2,166,883

AUSTRALIA		
Australia	826	\$ 223,498
New Zealand	10	4,765
T. Pac. Is.	—	—
Fr. Pac. Is.	2	660
TOTAL	838	\$ 228,833

AFRICA		
Algeria	—	\$ —
Br. East Africa	—	—
Canary Is.	40	8,543
Egypt	—	—
Ethiopia	11	4,488
Fr. Somaliland	5	1,593
Gabon	4	2,340
Ghana	—	—
Kenya	15	2,625
Liberia	9	6,825
Libya	8	6,000
Malagas	74	32,366
Morocco	7	5,500
Mozambique	25	4,180
O. W. Africa	—	—
Rep. Congo	—	—
Rhod. NY	37	12,062
Som. Rep.	—	—
Tanzania	—	—
Tunisia	—	—
Union So. Africa	69	14,030
TOTAL	304	\$ 100,552

GRAND TOTAL 69,424 \$24,318,754

COIN MACHINE VOLUME REPORT



MACHINES

VENDING MACHINES

1963 VOLUME (Jan.-Dec.)		1964 VOLUME (Jan.-Dec.)		1963 VOLUME (Jan.-Dec.)		
Units	Dollars	Units	Dollars	Units	Dollars	
NO. and CENTRAL AMERICA						
84	\$ 42,262	Bahamas	76	\$ 31,749	143	\$ 12,587
2	1,190	Barbados	—	—	—	—
121	56,848	Bermuda	58	13,292	38	5,434
—	—	British Honduras	—	—	—	—
3,446	884,066	Canada	7,571	1,528,881	4,228	1,181,571
4	820	Costa Rica	—	—	—	—
42	2,590	Dom. Rep.	5	2,463	232	3,823
—	—	El Salvador	5	1,625	—	—
3	2,196	Fr. West Indies	—	—	—	—
—	—	Greenland	—	—	—	—
11	1,100	Guatemala	—	—	—	—
—	—	Haiti	—	—	—	—
40	1,406	Honduras	—	—	—	—
—	—	Iceland	—	—	54	5,404
196	85,684	Jamaica	22	5,645	—	—
17	5,274	Lw Ww. Is.	—	—	—	—
—	—	Mexico	482	51,544	521	32,639
134	49,210	Neth. Antilles	—	—	—	—
—	—	Nicaragua	—	—	1	980
—	—	Panama	70	30,338	32	7,076
—	—	Trinidad	—	—	2	1,060
4,100	\$ 1,082,646	TOTAL	8,289	\$ 1,665,537	5,251	\$ 1,250,024
SOUTH AMERICA						
886	\$ 177,930	Argentina	18	\$ 9,216	24	\$ 5,655
—	—	Bolivia	—	—	—	—
—	—	Brazil	—	—	—	—
1	996	Br. Guiana	—	—	—	—
97	43,541	Chile	—	—	—	—
152	8,680	Colombia	27	3,010	—	—
—	—	Ecuador	110	2,064	253	4,395
9	3,372	Peru	5	1,079	—	—
27	12,527	Surinam	4	750	—	—
100	14,620	Uruguay	—	—	1	680
1,445	575,171	Venezuela	204	30,790	100	17,729
2,717	\$ 836,837	TOTAL	368	\$ 46,909	378	\$ 28,459
EUROPE						
65	\$ 34,192	Austria	125	\$ 42,883	358	\$ 71,852
16	13,220	Azores	—	—	—	—
7,110	2,407,713	Belgium	512	219,272	898	222,864
66	26,340	Cyprus	—	—	—	—
1,039	376,446	Denmark	126	48,475	15	2,735
391	131,929	Finland	182	137,354	188	115,600
11,571	5,226,449	France	623	155,677	492	70,908
785	182,720	Greece	—	—	—	—
29	17,100	Ireland	—	—	4	862
4,192	1,564,156	Italy	839	76,213	319	64,282
5	1,090	Malta	—	—	—	—
414	90,160	Netherlands	135	30,006	176	47,127
286	162,782	Norway	130	33,787	34	6,092
23	9,525	Portugal	—	—	—	—
255	70,929	Spain	143	150,243	1	566
848	383,084	Sweden	374	160,328	566	85,468
3,350	1,611,111	Switzerland	397	117,493	374	94,853
—	—	Trieste	—	—	—	—
48	22,020	Turkey	—	—	—	—
9,148	3,247,872	United Kingdom	2,134	562,949	1,954	383,861
4,974	2,199,195	West Germany	2,755	755,040	2,264	723,995
—	—	Yugoslavia	—	—	—	—
44,610	\$ 17,778,033	TOTAL	8,475	\$ 2,489,720	7,643	\$ 1,890,565
ASIA						
—	—	Arabia	2	\$ 1,970	33	\$ 3,098
—	—	Bahrain	—	—	—	—
—	—	Ceylon	—	—	—	—
73	14,653	Fed. Malaya	2	571	—	—
85	5,955	Hong Kong	—	—	3	1,246
—	—	India	—	—	—	—
28	8,200	Iran	—	—	—	—
49	5,410	Israel	—	—	2	1,006
244	73,214	Jordan	—	—	—	—
1,768	716,172	Japan	301	69,900	432	272,624
70	85,466	Korean Rep.	—	—	—	—
—	—	Kuwait	6	3,209	3	1,500
141	50,178	Lebanon	—	—	—	—
50	36,652	Nansei Is.	30	2,400	280	39,192
—	—	Pakistan	—	—	—	—
42	15,884	Philippine Rep.	229	72,413	57	16,230
13	2,675	Singapore	—	—	—	—
—	—	Syria	—	—	—	—
4	2,228	Taiwan	—	—	—	—
8	2,339	Thailand	—	—	—	—
8	3,074	Vietnam	253	16,835	1,183	17,653
2,583	\$ 967,100	TOTAL	823	\$ 167,298	1,994	\$ 353,149
AUSTRALIA						
394	\$ 123,015	Australia	81	\$ 27,119	225	\$ 45,562
46	15,252	New Zealand	—	—	—	—
5	1,813	T. Pac. Is.	—	—	—	—
1	650	Fr. Pac. Is.	—	—	—	—
446	\$ 140,730	TOTAL	81	\$ 27,119	225	\$ 45,562
AFRICA						
—	—	Algeria	—	—	—	—
—	—	Br. East Africa	—	—	—	—
38	12,810	Canary Is.	—	—	—	—
—	—	Egypt	—	—	—	—
2	1,500	Ethiopia	—	—	—	—
—	—	Fr. Somaliland	—	—	—	—
—	—	Gabon	—	—	—	—
—	—	Ghana	—	—	—	—
—	—	Kenya	—	—	—	—
—	—	Liberia	—	—	—	—
19	4,335	Libya	—	1,100	8	720
—	—	Malagas	—	—	—	—
12	5,151	Morocco	—	—	—	—
—	—	Mozambique	—	—	—	—
86	18,954	O. W. Africa	—	—	—	—
4	2,000	Rep. Congo	—	—	—	—
—	—	Rhod. NY	1	800	—	—
21	5,303	Som. Rep.	—	—	—	—
—	—	Tanzania	—	—	—	—
—	—	Tunisia	—	—	—	—
27	11,838	Union So. Africa	515	53,916	25	4,500
209	61,391	TOTAL	518	\$ 55,816	33	\$ 5,220
54,665	\$ 20,866,737	GRAND TOTAL	18,554	\$ 4,452,399	15,524	\$ 3,572,979

ARCADES ARE PROFITABLE

Munves Can Give You
Complete Installation
Of
ARCADE
BILLIARD ROOMS
GROUP GAMES

Write For Arcade Catalogue
Parts & Supplies For All
Billiard—Amusement Machines

MIKE MUNVES CORP.

577 Tenth Ave., New York 36, N.Y.
BRyant 9-6677

THE ORIGINAL!!

KICKER and CATCHER
the COUNTER GAME with
BUILT-IN-PROFITS



J. F. FRANTZ MFG. CO.
1940 W. Lake St., Chicago 12, Ill.
Tel: Taylor 9-2399

PRESTO COIN CHANGER



With Funnel Top
available again.
The only coin-
changer built to
take the punish-
ment of constant
use. The new fun-
nel top permits
coin-tube to be
filled in a flash.
Create good will
and increase play
by giving your lo-
cation a PRESTO.

Nickel, Dime and
Penny Models \$1995
ea.

Write for Quantity Prices.

NEW ORLEANS NOVELTY COMPANY
1055 Dryades Street New Orleans 13, La.
(Exclusive National Distributor)

*Coin-operated
phonographs?*

**CHECK
THESE
ADVANTAGES
OFFERED TO
THE ORIENT BY
NORTHWEST
SALES CO.**

experience

Northwest Sales Company is one of the oldest coin-operated machine distributors on the West Coast and has provided over 29 years of continuous service to the industry.

name brands

As one of the older franchised Wurlitzer distributors, Northwest Sales Company is also taking trade-ins of AMI's, Rock-ola's and Seeburgs. You buy the best for less at Northwest!

selection

As a volume distributor, Northwest Sales Company is able to maintain one of the largest stocks of quality, used merchandise available.

service

Ron W. Pepple and Marshall McKee of Northwest Sales are known for delivering what they promise. Your satisfaction is assured by their over 64 years of combined know-how and experience.

established 1936

NORTHWEST SALES CO.

SEATTLE OFFICE

Ron W. Pepple
3150 Elliott Ave.
Seattle, Wash. 98121
Phone 206-284-8030

PORTLAND OFFICE

Marshall McKee
1040 S. W. Second Ave.
Portland, Ore. 97204
Phone 503-228-6557

Cable address: **JUKEBOX**

THE REPORT FROM GREAT BRITAIN:

Juke Box Installations Off 7%; Collections Drop 12%; Competition From Other Media Keen



LILLIAN SHAW
HONORARY SECRETARY P.O.A.

Not a landslide but a sizeable drop is the story of G.B.'s jukebox trading throughout this period. New installations down 7 per cent; cash takings per box down 12 per cent. Reasons numerous, but perhaps the chief one is increased competition not only among operators but in the music business generally. Up to this year, sound and vision broadcasting has been more or less a state monopoly, which granted a few—very few—licenses to selected operators. Recently, however, pirate broadcasting stations have ventured forth with programmes going out on channels at present unused. These broadcasts work the clock round by means of three ships anchored off the coast line, with the centre vessel equipped with a 50 k.w. transmitter. Booster ships are positioned by way of re-inforcement, and customers, by purchasing at trifling cost a simple tuning coil, get a 24-hour service of non-stop music. And that is 'some competition.'

Another reason for the decline is loss of appeal now being widely experienced by pop music which, of course, claims a star position in most jukebox programmes. Though the music industry as a whole is doing quite nicely, pop groups are folding overnight. The extraordinary thing about this factor is that tickets to pop concerts not only sell out but often go to a premium, while live performance bookings for top turns stretch here and there for months—one star of my acquaintance is actually turning down dates for two years ahead—but the graph is falling fast and the pirates are scooping the business. An additional nail in the coffin, which some experts describe as actually the real problem, is the complete absence of a genuine trade wind. No one in this

Island is able to discover what the public wants. Groups are said to be out of favour: yet 24 of the pop fifty are currently groups, while many soloists carry group backing. These contradictions fog the issue; what is clearly wanted is a lead. There has been no outstanding trend since Elvis Presley's rock 'n roll. Tom Sloan, head of B.B.C. entertainment sector says of pop music programmes: "None of these shows give me any personal satisfaction. I am bored to death with most of the so-called talent in the pop music field at this moment. What I object to is the standard displayed, and what the public are apparently willing to accept. I have no idea how long this acceptance will last, but there is no doubt that the thousand and one beat groups in Great Britain are being reduced in numbers, for the simple reason that many of them are too bad to earn a living, and they are going back to what they did before."

Grading reasons for recession is never an easy task. A very old hand confidently asserts that the phenomenal success of the 'stately home' trade, which has pitchforked some thousand ancient and historic houses into show places, has resulted in coin going into individual instead of into phonograph slots. True, jukeboxes are installed in many of these show places, but there is so much to allure normal humanity that music becomes merely one of a galaxy of attractions. Incidentally, operators have a unique advantage in that a Government subsidy of 175,000 dollars a year is granted on the ground of maintaining national relics, and should an operator have a particularly bad year through no fault of his own, he has only to apply for special aid and has an odds-on chance of getting it. Attractions offered by this outstanding branch of the British entertainment industry include water skiing, private zoos, miniature railways, slot-vision, phonographs and motorcycle races. Exhibitions of and competitions in old 'vintage' cars are a prominent feature of the side-lines. The 650,000th visitor has already passed through the turnstiles at Berkeley Castle, and this is by no means one of the leading sites. Customers staying for bed and breakfast, including dinner with a titled proprietor, are charged around 120 dollars.

Personally, if I am asked for an opinion on the trade drop, the answer is that a large part of the public's spending money which would normally be slotted by jukeboxes is at present being channelled through the media of gaming units. These jobs have only recently received official, if limited, sanction in public places. The sudden freedom of restraint encourages excess, a factor which may, in the long term, be the undoing of the proposition.

WE CARRY A COMPLETE LINE OF

★ COIN COUNTERS

★ COIN SORTERS

★ COIN COUNTING
COMBINATIONS

★ COIN CHANGERS

★ COIN WRAPPERS

★ PARTS & SUPPLIES

★
Will Count and
Sort Coins of
All Nations!

★
Compte et trie les
pieces de monnaie de
tout pays!

★
¡Cuenta y clasifica
monedas de todas las
naciones

★
Diese maschine
zählt und sortiert
die münzen aller
länder!

Wire! Write! Phone!

Charles (Jimmy) Johnson

GLOBE DISTRIBUTING CO., INC.

2330 N. WESTERN AVE.

CHICAGO 47, ILLINOIS

ARMITAGE 6-0780

"nearer
the
Orient"

European Trade Organizations

AUSTRIA

Verband des Osterreichischen Automaten-Gewerbes, Brucknerstrasse 4/8
Wien IV, Dr. Rudolph Rampf.

BELGIUM

U.B.A. UNIE VAN DE BELGISCHE AUTOMATENBRANCHE
UNION BELGE DE L'AUTOMATIQUE,
228, Rue Theodore Verhaegenstraat,
Brussels 6, Belgium

DENMARK

Foreningen AF Fabrikanter Og Opstillere AF Musikautomater
I Danmark.
Lyskaer, 8, Herlev-Copenhagen. Mr. Edwin Jensen.

FRANCE

SYNDICAT NATIONAL DES FABRICANTS D'ELECTROPHONES
AUTOMATIQUES
72, Boulevard De Montparnasse, Paris, Mr. Bouzanquet.
Federation Francaise Des Exploitants et Commerçants de L'Automatique.
38bis, Rue Vivienne, Paris (2e). Mr. Jean Faraut.
Syndicat National Des Professionnels De L'Automatique
104, Boulevard de Clichy, Paris. Mr. Charlot.
Syndicat National Des Importateurs-Exjortateurs D'Appareils Auto-
matiques.
1, Quai de Grenelle, Paris 15e. Mr. Gaillard.

GERMANY

V.D.A.I. Verband der Deutschen Automatenindustrie eV, Koln-Lindenthal,
Aachner Strasse 199, Cologne. and W 15, Lietzenburger Strasse 36,
Berlin. Contact Dr. Jutzi, Bad Kreuznach, First Chairman; Herr Gunter
Wulff, Vice-Chairman, Berlin. (Assoc. of German manufacturers of
automatic machines)

ZOA

Zentralverband der Organisationen des Deutschen Automaten
Aufstellgewerbes

Koeln, Kaiser-Wilhelm-Ring 6-8

President: Mr. Hasso Loeffler, Cologne

(Central Organization for German operators with association in the 11
countries of the German Federal Republic).

DAGV

Deutscher Automaten-Grosshandels-Verband eV

Hamburg 1, Grosse Baeckerstrasse 3

President: Mr. Heinz Kaestner, Rothelmshausen Bez. Kassel

(Association of the German wholesalers of automatic machines)

Grosse Baeckerstrasse, 3, Hamburg 1. Mr. Helmut Neuberg.

Verband der Automatenbetriebe eV

Eichenstrasse 53, Hamburg 19. 1st President: Mr. Lars K. Skriver (The
German Amusement Arcade Owners' Association).

GREAT BRITAIN

AMUSEMENT CATERER'S ASSOCIATION

Gloucester House 19, Charing Cross Road, London W.C.2. Mr. John
Singleton.

Amusement Trades Association

72a, Walton Road, East Molesey, Surrey.

P.O.A. The Phonograph Operators Association

76B, Rochester Row. S.W.1. Mrs. L. Shaw.

IRELAND

Amusement Caterers Association of Northern Ireland.

6, Carlisle Circus, Belfast. 14. Mr. J. H. A. Swinson.

ITALY

S.A.P.A.R. Associazione Nazionale Noleggiatori Apparecchi Automatici.
Via di Villa Patrizi 10, Roma. Mr. A. Ricardi.

ASSOCIAZIONE NAZIONALE NOLEGGIATORI APPARECCHI
AUTOMATICI

Pza Buonarrotti 24, Milano. Mr. F. de Fendi.

NETHERLANDS

A.U.T.E.X. Bond Van Muziek En Amusementsapparaten.

2e Westewagenhot k, St. Laurensuis, Rotterdam. Mr. P.H.M. Hoogen-
bergh.

Music Co-Operation

Rechthuisstraat 8, Rotterdam. Mr. H. J. de Groot.

Prof. Dr. Schuh Foundation, P.O. Box 4, Bergen Op Zoom, Holland,

Pres. J. F. Vale

SWEDEN

Sveriges Automatagares Riksforbund

Vanadisplan 5, Stockholm 21, Mr. Van Gyllenpalm.



PHONOGRAPHIC EQUIPMENT (Distributors) LTD.

BRITAIN'S BIGGEST DISTRIBUTORS

OF COIN OPERATED AMUSEMENT MACHINES

EXMOOR ST. BARLBY ST. LONDON. W. 10.

• WILLIAMS • BALLY • JUPITER
SEGA • UNITED • MIDWAY

1 BELAMEX MEANS SERVICE

number 1
in export

immediate
delivery anywhere
in Europe from our
Antwerp Warehouse

COMPLETE SELECTION OF ALL MODELS

SEEBURG • WURLITZER • ROCK-OLA
ROWE-AMI • GOTTLIEB & WILLIAMS
PINGAMES • BALLY BINGOS

for complete in-
ventory and in-
formation con-
tact . . .

GOTH & CO.

17A Korte Winkelstraat,
Antwerp, Belgium

THE BELAM COMPANY, INC. 
51 Madison Ave., New York 10, N.Y.
Mu 9-5633-4-5

EXPORTING ALL
OVER
THE WORLD

Simon Distributing Co.

2833 W. Pico Blvd.
Los Angeles, Calif.

Cable Address
Simondist

IMPORTERS

ATTENTION!

For Best Prices
Coin-Operated
Equipment

Contact:

PURVEYOR DIST. CO.

4322 N. Western Ave., Chicago, Ill.
PHONE: JU niper 8-1814



MONDIAL

**Brings the
European Market
to the doorstep
of America's
Coin Machine Factories**



**MONDIAL COMMERCIAL
CORPORATION**

350 Fifth Avenue, New York City
Telephone: Wisconsin 7-5669
CABLE ADDRESS: MONDINOV NEW YORK

**Exclusive U.S. Manufacturers
Representatives
serving worldwide markets
through an established
network of Official Distributors.**



MONDIAL INTERNATIONAL INCORPORATED

350 Fifth Avenue New York City
Telephone: Wisconsin 7-5661
CABLE ADDRESS: NYMONDIAL NEW YORK

**FREE...
FREE...
FREE...**

**NEW PEACH STATE
1965**

**Coin Machine Parts
& Supplies Catalog
288 Pages**

**LARGEST COIN MACHINE PARTS
& SUPPLIES CATALOG EVER
PUBLISHED**

**Replacement Parts
Listings for All
Major Manufacturers**

**AMI • BALLY • CHICAGO COIN
GOTTLIEB • KEENEY • MIDWAY
ROCK-OLA • SEEBURG • UNITED
WILLIAMS • WURLITZER**

**SOUTH'S LARGEST
DISTRIBUTOR
OF
COIN MACHINES
PARTS
AND
SUPPLIES**

peach state
DISTRIBUTING COMPANY

**1040 BOULEVARD, S. E. TELEPHONE 622-4401
ATLANTA • GEORGIA • U. S. A.**

**CATALOG
265
NO.**

**EUROPEAN
MANUFACTURERS**

Juke Boxes

BELGIUM

DISCOMATIC
Lange Kievitstraat 83,
Antwerp.

ETS. RENNOTTE
83, Rue Gustave Masset,
Gembloux.

N.V. SUGGEST-TOEBOSCH
Lange Leemstraat 113-115,
Antwerp.

FRANCE

SOCIETE BAL-AMI.
40, Rue Saint-Amand,
Le Touquet, Paris-Plage.

ETS. BONZINI.
34-36, Rue Desirie Vienot,
Bagnole/Seine.

CAMECA.
103, Boulevard Saint-Denis,
Courbevoie.

CIFA
72, Bd. du Montparnasse,
Paris 14.

CITEP.
44, Rue du Colisee,
Paris 8.

S.A. ELECTRONIQUE & MECANIQUE,
Rue Bol Respiro,
Monte Carlo/Monaco.

ELECTRO-KICKER SA,
Baume Les Dames,
Doubs, Charles Gosteli

FLESH EDITIONS VOG,
Palais Berliz,
Paris.

INTER FRANCO-SUISSE
79, Bd. du Montparnasse,
Paris.

ETS. MARCHANT.
7-9, Rue Voltaire,
Levallois.

C. MARTINA.
22, Avenue Jean Jaures,
Paris.

MARCEL AUTOMATIQUE EUROPEEN,
7, Rue de Tournus,
Paris 15e.

STE. MATEBOIS,
39, Avenue du General Leclerc,
Chalette sur Loing.

SCOPITONE (Cameca)
103 Blvd. St. Denis,
Courbevoie

SOCIETE MIAMI.
13, Rue P. Lafargue,
Putteaux (Seine)

MICRO MUSIU.
47, Bis Rue de Bellevue,
Creteil (Seine)

MUSIMATIC.
8, Rue du Mont Thabor,
Paris 1e.

MAURICE PLOTCHENKO,
60, Rue de Provence,
Paris 9c.

ETS. RENE PIERRE RANCHOT,
18, Rue Mazagran,
Paris 10e.

SOCIETE SECEMAU (STELLA)
4, Rue Scipion,
Paris 5e.

SEME AUTOMATIC,
17, Rue de Marignan,
Paris.

STE. SMAME
45, Rue des Boulets,
Paris.

**SOCIETE INTERNATIONALE DE
PHONOVISION**
60, Rue de Provence,
Paris 9me.

ETS. RENE WOLFF,
141, Ave. de Verdun,
Iss-les-Moulineaux.

GERMANY

TH. BERGMANN & CO.
Eimbteler Str. 45a,
Hamburg-Altona

BEROMAT GMBH.
Tauentzienstr. 6,
Berlin. W.30.

CANTEN AUTOMATENBAU, GMBH,
Neu-Isenberg/Frankfurt
Hathenastrasse 53.

DEUTSCHE WURLITZER GMBH.
Krs. Lubbecke (Westf)
Hullhorst.

EICHHOFF-WERKE GMBH.
Und Schlitz in Hessen,
Ludenscheid i. W.

ELTEC
Nollendorfstr. 11-12,
Berlin, W. 30.

HEINRICH HECKER
Kapellendorfstr. 4,
Paderborn.

LOEWEN-AUTOMATEN,
Bingen/Rhein.

NOVA-APPARATE GMBH.
Semperstrasse 24
Hamburg

NSM APPRATBAU
Alzeyer Str. 51,
Bingen/Rhein.

L. ROHDE
Neuer Wall 38,
Hamburg 36.

Complete Listings on All Supplies

**BALLS, Bowling • BOOKS, Collection • BULBS • CLEANERS • COIN CHANGERS • COIN CHUTES • COIN
COUNTERS • COIN DISPENSERS • COIN SORTERS • COIN WRAPPERS • CONTACT PARTS • DECALS
FLUORESCENT BALLASTS, FUSES, LAMPS, STARTERS • LEG LEVELERS • LOCKS • LUBRICANTS • NEEDLES
PAINTS • PHONOGRAPH RESTYLING KITS • POOL TABLE SUPPLIES • PUCKS • RUBBER RINGS • SHUFFLE-
BOARD SUPPLIES, Cleaners, Waxes, etc. • SLUG REJECTORS • SOLDERING GUNS • SPEAKERS • SWITCHES
TAPES • TESTERS • TITLE STRIPS • TOOL BAGS & BOXES • TOOLS, Hand & Power • TRUCKS • TUBES
TRANSFORMERS • WAXES • WIRE.**

PLUS: Page After Page Listing Useful Information

- MOTOR CHARTS FOR GAMES
- NEEDLE CHARTS FOR PHONOGRAPHS
- TUBE CHARTS FOR AMPLIFIERS
- FLUORESCENT CHARTS FOR PHONOGRAPHS

WRITE FOR YOUR FREE COPY TODAY

Peach State Distributing Co.

1040 Boulevard, S. E.

Atlanta, Georgia 30312

Phone: (404) 622-4401

AMERICA'S LEADING MANUFACTURER



SUN-GLO



**Pucks
Products
for
Shuffleboards**



SEE YOUR LOCAL DISTRIBUTOR TODAY!

Sun-Glo Shuffleboard Supplies, Inc.

**111-113 HECKEL ST. BELLEVILLE 7, N. J.
Phone: PLymouth 9-4474**

**Our Modern
new Factory
is devoted
exclusively to
manufacturing**



**SCHMELKE
QUALITY CUE STICKS**

Professional Design—Long Life

Write for details.

**SCHMELKE MFG. CO.
SHAKOPEE, MINNESOTA**

EUROPEAN MANUFACTURERS

Juke Boxes

(Continued from page 32)

TONO-AUTOMATEN
Rathenastrasse 53,
Neu Isenburg bei
Frankfurt/Main.
**TREFF SPEIL UND
WARENVERKAUFAUTOMATEN**
Meinekestr. 3.
Berlin. W. 15.
UTA-ELEKTROAKUSTIK
Magstadt bei Stuttgart.
GEORG WIEGANDT & SOHNE,
Ziegrastr. 15-19,
Berlin-Neukolin.
WULFF APPARATEBAU,
Tauentzienstrasse 6,
Berlin W. 30.

GREAT BRITAIN

CHANTAL LTD.
Station Road
Kingswood, Bristol

HOLLAND

JOS. VAN OSCH,
Kerkstraat A55,
Kerkdriel.

ITALY

S.I.F. CINEBOX
Filmshows for Cinebox
Brevetti Mondiali Cinebox
Via Marco Polo 7, Milano
SOCIETE INTERNATIONALE SONOVISIONE.
Via Torino 40,
Rome.
Corso Matteotti, 8, Milano.

SPAIN

GEDASA
Valderribas 52,
Madrid.

SINFONOLA
San Quintin, 10,
Madrid.

EUROPEAN MANUFACTURERS Amusement Machines

BELGIUM

AUTOMATENFABRIEK JODEK
Koopbandelstraat 2
Wetteren
BELGEX AUTOMATIC LTD.
Rue Capouillet 37,
Brussels 6.

DENMARK

DANOMAT
Falkoner Alle 66,
Copenbagen.
PAUL KRISTENSEN
Damhus Boulevard 55,
Copenhagen-Valby.
O & E STEFANSEN,
Bogbolder Alle 40,
Copenhagen-Vanlose.
BRDR. STEFANSEN,
Brobolms Alle 5a,
Copenhagen-Charlottenlund.
TESTO A/S.
Frederikberggade 3,
Copenhagen.
TRITA TRADING CO.
Falkoner Alle 66,
Copenhagen.
**ESBJERG UNDERHOLDING
AUTOMATENFABRIK**
Gamie Faergevej,
Esbjerg.
HANS ZIRSEN
Steen Blicbersvej 22,
Copenhagen.

FRANCE

SOCIETE ALEBN
43, Rue d'Enghien,
Paris 10.
ETS. BONZINI
34-36, Rue Desire Vienot,
Bagnole/Seine.
ETS. BUSOZ
79, Rue de Clignancourt,
Paris 18.
ETS. CLERGE
12, Rue de Girondis,
Lyon/Rbone.
ETS. PIERRE MAILLARD
20, Rue Jules Grosjean,
Montbeliard.
ETS. RALLY
98, Ave. St. Lambert,
Nice.
ETS. V. SALMON
108, Bd. de Courcelles,
Paris 17.
STE. SECEMAU (STELLA)
4, Rue Scipion,
Paris 5.
SOPIMA
16, Rue Thiers,
Grenoble/Isere.
SOFRADIC
35, Rue Croix-Nivert
Paris 15.
UNIMECA
11 bis. Avenue Kleber,
Paris.

GERMANY

AUTOMATENBAU FOERSTER GMBH
Lange Strasse 87.

TH. BERGMANN & CO.
Eimsbueteler Str. 45a,
Hamburg-Altona.

DR. HANSBERG.
Bliesmuhle,
Neunkirchen/Saar.

HOFFMANN (PAY-OUTS)
Hellenthal.

**IMO-AUTOMATENFABRIK HELM
JENTZSCH GMBH.**
Bielefelder Str. 76,
Nielefeld-Brackwede.

HANS JOHANNSEN
Battenberg/Eder

KICKER GMBH.
Niederbardenberg/Aachen.

A. KOSTER
Schwarzbach 130,
Wuppertal-Oberbarmen.

LOWEN-AUTOMATEN
Am Freidhof,
Bingen/Rhein.

BILLARDFABRIK NOBILING
Bismarckstr. 65.
Berlin-Cbarlottenburg.

RUDOLF NAUDASCHER
Moslestr. 17,
Freiburg i. Br.

K. MOSCHKE
Klinikstrasse 16,
Wurzburg.

N.S.M. APPARATEBAU
Alzeyerstrasse 51,
Bingen/Rhein.

HELMUT REHBOCK
Alter Teichweg 19,
Hamburg 22

SCHMIDT UND GERDES
An der Bottmuhle 5,
Cologne.

P. W. WENZEL
Sternstrasse 3,
Gelsenkirchen.

WESTAUTOMATEN G. HILTGENS K.G.
Krefelder Str. 65,
Moers.

WESTAV
Rothelmsbausen,
Post Wabern bez. Kassel

**WINKLER AUTOMATEN GMBH.
(PAY-OUTS)**
Hobenzollernring 2-10,
Cologne.

GEORG WIEGANDT & SOHNE
Ziegrastrasse 15-19,
Berlin-Neukolin.

WULFF-APPARATEBAU
Tauentzienstrasse 6,
Berlin W. 30.

GREAT BRITAIN

AINSWORTH CONSOLIDATED (G.B.) LTD.

ARISTOCRAT HOUSE
2a, Kimberley Gardens,
Harringay,
London, N. 4.

AUTOMATIC MACHINE SALES LTD.
147, Perry Vale,
London, S.E. 23.

AUTOMATEN DISTRIBUTORS LTD.
46, Mostyn Street,
Llandudno,
Wales.

BELL FRUIT MANUFACTURING CO. LTD.
Leen Gate, Lenton,
Nottingham.

BRYANS WORKS
Kegworth,
Derby.

CROMPTON & BATES
166-172 High Street,
Ramsgate, Kent.

CHICAGO AUTOMATIC SUPPLY CO.
218, Sbaftesbury Avenue,
London, W.C.2.

DITCHBURN EQUIPMENT LTD.
Dock Road,
Lytham, Lancashire.

GOLDING AUTOMATICS LTD.
37, London Road,
Marks Tey, Colchester,
Essex.

K. & R. EDWARDS
28, James Street,
Bath, Somerset.

EDWIN HALL & CO.
67, Besey Street,
London, S.W. 16.

KRAFT'S AUTOMATICS LTD.
158, Stoke Newington Road,
London, N. 16.

PARKER AUTOMATIC SUPPLIES LTD.
38, West Parade,
Rbyll, Flintshire

MILLERS (MULTI-SLOTS) LTD.
4, Norham Road,
Whitley Bay,
Northumberland

R.G. MITCHELL (SALES) LTD.
Briar Way, Skegness,
Lincolnshire.

MORRIS SHEFRAS & SONS LTD.
225, Blackfriars Road,
London, S.E.1.

MILLS NOVELTY COMPANY LTD.
Weir Mill, Manchester Road
Mossley, Asbton-under-Lyme,
Lancashire.

MONTE CARLO MACHINE CO.
4 Leicester Road,
Blackpool, Lancashire

RUFFLER & WALKER LTD.
33-37, St. John's Hill,
London, S.W. 11.

SAMSON NOVELTY CO. LTD.
43-45 White Hart Lane
Barnes S.W. 13
London

STANDARD COIN COUNTING COMPANY
2, Glendower Place,
Old Brompton Road,
London, S.W.7.

STANNITE AUTOMATICS
70/72, Markfield Road,
Tottenham,
London, N. 15.

PHILIP SHEFRAS LTD.
Holly Bush Place,
Betbnal Green,
London. E. 2.

STREETS AUTOMATIC MACHINE CO. LTD.
Stanstead Road,
Eastbourne,
Sussex.

G. A. WHITTAKER LTD.
4, Leicester Road,
Blackpool.

WALDORF ENGINEERING COMPANY
90, Norwich Road,
Cromer, Norfolk.

WHITTAKER BROS. (SHAW) LTD.
Sbaw, Oldham,
Lancashire.

HOLLAND

DESCO (VAN DESSELL)
Reebthuislaan 8,
Rotterdam.

GAMO N.V.
Oosterbamrikkade 88,
Groningen.

ITALY

BREVETTI FASNA
Via Monte Rosa 35, Torino

BRUNO MANGOLINI
Via Boccacio 215,
Sesto S. Giovanni.

MANIFATTURA ANGA
Via Canate No: 55,
Sommariva Bosco
Sidam, Via Rubiana 52,
Torino

SPA MICROTECNICA
Via Madama Cristina 147
Torino

S.P.A. NOTOMAT
Viale Petrarca 76-78,
Livarno.

ANDREA PESCE
Novi Ligure.

GIORGIO VIANI
Caciolle 15,
Florence.

NORWAY

GNISTEN KNUT ANDRE
Maridalsveien 34,
Oslo

TANA JERNINDUSTRI
Nesttun.

SWEDEN

SPELAUTOMATEN A/B
Limbamswagen 6b,
Malmo.

SPAIN

FABRICA DE AUTOMATAS
Gonzalo Castello Gomez,
Valderribas 52,
Madrid.

**GENERAL ESPANOLA DE AUTOMATICOS
S.A.**
Capitan B. Ribera 30,
Guadalajara.

AUTOMATICOS C.M.C.
Zaragoza,
Delicias 27-29.

INDUSTRIAS LAGUNA
Traversa de la Corta 78,
Barcelona.

INTER-AUTOMATIC
Arzobispo P. Claret,
Barcelona.

PETACO
Santa Feliciano 5,
Madrid.

SALOR S.A.
Avda. Jose Antonio 600
Barcelona.

VAHER
Doctor Ayala 12,
Alicante.

SWITZERLAND

FR. H. HOLENWEG
Herzogenbuchsee /BE

MAISON L. LAPORTE
Vesenev-Geneva.

SPORLUX S.A.
Vesenev-Geneva.

SPORTFOOT S.A.
Via Gardo Franca,
Lugano.

RUNYON

SERVING THE OPERATOR ...
SERVING THE INDUSTRY ...
ALWAYS WITH A SMILE!

Distributors for the finest
Coin-Operated Equipment:

MUSIC AMUSEMENT
VENDING
BACKGROUND MUSIC



The Rowe-AMI DIPLOMAT
Phonograph
Featuring 3-in-1 styling!



The Rowe AC RIVIERA Cigarette Vendor
Good looking, dependable!

The Rowe AC FULL-LINE Vendors
A Vending Machine for every
location!

TOP AMUSEMENT LINES!

BALLY	IRVING KAYE
WILLIAMS	KEENEY
MIDWAY	ALL-TECH
GOTTLIEB	UNITED

Complete EXPORT Service

Available through
RUNYON INTL. INC.

Wide Selection of
Reconditioned Equipment
CABLE: RUNYONEX, SPRINGFIELD, N.J.

ONE-STOP SHOPPING AT RUNYON!

SHUFFLES — PINS — GUNS — KIDDIE RIDES
— PARTS & SERVICE — RECORD DEPT. —
SHOPS — SPRAYROOMS — LUXURIOUS SHOW-
ROOMS — VISIT US!

RUNYON SALES CO. INC. RUNYON INTL. INC.

U.S. Route 22, Fadam Road, Springfield, N.J.
Tel DRexel 6-8720

593 Tenth Avenue, New York, N.Y.
LOngacre 4-1880

306 Tolland St., East Hartford, Connecticut
BUtler 9-4303

Make Money With Coin

MAGIC-BOX

NEAPOLITAN PIANOLA JUKE-BOX, A Marvelous Little Unit
IT'S A LITTLE WONDERFUL JUKE-BOX
ITALIAN STYLE (OR NEAPOLITAN STYLE)

An automatic unit, equipped with a multiple selector unit which makes it possible to listen in succession to 50 records (100 selections).



WATER POLO

FEATURES:

- ★ Equipped with a timer, to set the playing time.
- ★ 4 Can Play
- ★ The Cabinet is All Formica
- ★ Pistols Mounted on Bushings to Prevent Spillage of Water.
- ★ Minimum Dimension:
Height — 1.03 meters — Length — 1.20 meters, and width 0.70 meters.



BALL POLO — TWO-PLAYERS

FEATURES:

- ★ When the token is inserted in the slot, the balls are released.
- ★ The game is played between two players and it is started by placing the first ball in center field.
- ★ By manipulating the two opposite handles in the shape of a pistol, situated at both ends of the field, the two players hurl the iron balls to oppose the enemy.
- ★ try of the plastic ball into the proper net. The greater number of nets wins the game.
- ★ The game time is 5 minutes, and when this time span is up the balls are once again blocked inside the table proper.
- ★ The game is played skill against skill and the winner is the party with the higher skill, so that a greater number of nets is scored to win.

*DIMENSIONS: Height 100 cm Width 58 cm
 Length 110 cm Weight 50 kg

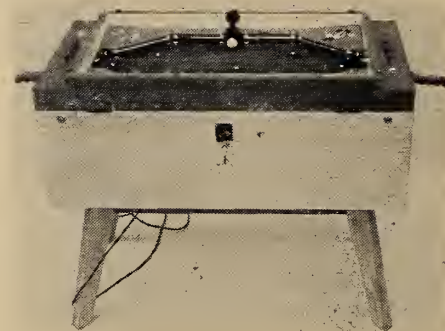

GALLOPING HORSE

Fitted to perform at all current supply ratings and provided with a timer, regulating the time of play, which is 6 minutes. The horse is a varnished duraluminum casting with a cellulose base varnish so that no water damage will occur.

LEATHER AND SKIN FINISH.

CAN BE INSTALLED IN THE OPEN — DOES NOT SUFFER DAMAGE FROM WEATHER.



L'Automatico

Via Galeotti 12—BOLOGNA (Italy)
Phone 510345
Telegrams: L'Automatico-Bologna

Operated Games-Italian Style

BASKET BALL GAME



- ★ The game is timed with a timing clock
- ★ The cupola (dome) is a plexiglas casting and the field proper is of plastic.
- ★ Small dimensions:

Height: 1.30 meters

Length: 1.35 "

Width: 0.80 "

THE HUNTING CRANE, 1965

MOST POPULAR THROUGHOUT THE WORLD!

This game gives you the pleasure of hunting for candies, cigarettes (whole packages)

- ★ A 12-relay frame—24 volts, interchangeable
- ★ Tilt Safe, essential for this game
- ★ Belgian Glass Frame with Luminous Indices showing the progress of the game. Self-braking motors.
- ★ Elastic Frame
- ★ Three Speed Control

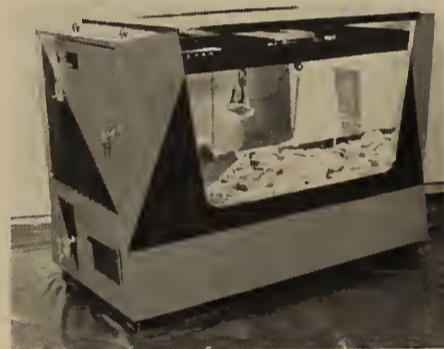

BABY BALL GAME

Can be shifted from place to place!

THIS IS AN UNUSUAL FOOTBALL GAME; a two player, or four player game. There are 11 little men in each team playing with a little ball.

These little men are moved by players.

L'automatiko

Via Galeotti 12 - BOLOGNA (Italy)

Phone 510345

Telegrams: L'Automatico-Bologna

U. S. MANUFACTURERS

with

WORLD WIDE REPRESENTATIVES

AMERICAN

AMERICAN SHUFFLEBOARD CORPORATION
210 Patterson Plane Rd.
Union City, N.J.
Write for foreign representatives

AUTO-PHOTO

AUTO-PHOTO COMPANY
3300 Central Avenue
Los Angeles, California
(Subsidiary of Photo-Me Int'l.)

PHOTOME LIMITED
Hersham Trading Estate
Hersham, Surrey, England

PORTEX, S.A.R.L.
4, Square Rapp
Paris VII, France

SCHNELLPHOTOAUTOMATEN

G.m.b.H.
47 Viersener Strasse
Krefeld, West Germany

FOTOFIX SCHNELLPHOTO-AUTOMATEN, G.m.b.H.
Praterstrasse 36, Door 6
Vienna, Austria

NIPPON AUTO-PHOTO K.K.
3 Enokizaka-machi
Akasaka, Minato-ku
Tokyo, Japan

BALLY

BALLY MANUFACTURING COMPANY
2640 Belmont Avenue
Chicago 18, Illinois
Write for Foreign Distributor Information

CHICAGO COIN

CHICAGO DYNAMIC INDUSTRIES,
1725 W. Diversey
Chicago 14, Illinois
Write for Foreign Distributor Information

CINEBOX

(Licensee)
DAVID ROSEN INC.
855 No. Broad St.
Philadelphia, Pa.

DUNCAN

DUNCAN SALES
737 Carnegie Ave.
Cleveland, Ohio
(Licensee)

EXHIBIT

EXHIBIT SUPPLY CO.
4218-30 W. Lake St.
Chicago, Ill.

GOTTLIEB

D. GOTTLIEB & CO.
1140-50 North Kostner Avenue
Chicago 51, Illinois

FRANCE, NORTH AFRICA, BENELUX, BRITISH ISLES, ITALY AND SPAIN

Mondial Commercial Corp.
Empire State Building
350 Fifth Avenue
New York, N. Y.

GERMANY AND AUSTRIA

Nova Apparate GmbH & Co.
Semperstrasse 24
Hamburg 39, Germany

SWITZERLAND

Eric de Stoutz
1 Avenue du Mail
Geneva, Switzerland

SCANDINAVIA

Aktiebolaget Freius Danneman
Grenstigen 9
Lidingo 5, Sweden

PUERTO RICO

All Coin
Amusement Company
2495 N. W. 77th Terrace
Miami, Florida

QUEBEC, CANADA

Laniel Amusements, Inc.
151 Rockland Avenue
Town of Mont Royal
Montreal, Quebec, Canada

WINNIPEG, MANITOBA, CANADA

Monarch Coin Machine Co.
211 Rupert Avenue
Winnipeg, Manitoba, Canada

JENNINGS

JENNINGS MANUFACTURING CO. CONTACT:

Bankers World Export Co.
1009 E. Baltimore St.
Baltimore, Maryland

MAR-MATIC SALES LTD.
31-35 Kirby St.
Hatton Garden
London E. C. 1, Eng.

MIDWAY

MIDWAY MFG. CORP.
10136 Pacific Ave.
Franklin Park, Ill.

Foreign Representative:

MONDIAL COMMERCIAL CORP.
350 Fifth Ave.
New York, N.Y.

MILLS

MILLS BELL-O-MATIC INTERNATIONAL CORP.
Leonard Haines Inc.
35 Mercer St.
New York 13, N. Y.

MUTOSCOPE

International Mutoscope Corp.
11-12 44th Avenue, Long Island City, N.Y.
International Distributors
Belamex Vending Intl.
51 Madison Ave., New York City
(Continued on page 16)

PATTERSON

L. T. PATTERSON DISTRIBUTORS
10 Rockwood Bldg.
Cincinnati, Ohio

R.F. JONES CO.

EXCLUSIVE DISTRIBUTORS

ROWE ★ AMI ★ BALLY

IN ORBIT ... with
the coin equipment that MOVES



Seven Offices to Serve Operators in America
and Throughout the World

SAN FRANCISCO
240 SHOTWELL STREET
KLondike 2-3579

LOS ANGELES
1269 SO. FIGUEROA ST.
Rlchmond 9-7405

R. F. JONES (Far East Ltd.)
1-22 YOYOGI, SHIBUYA-KU
TOKYO, JAPAN
370-4111

SALT LAKE CITY
375 SO. SECOND WEST
ELgin 9-2029

SEATTLE
309 NINTH AVE., NORTH
MAin 4-7594

CABLE—JONCO

DENVER
2830 WEST 9TH AVENUE
Denver, Colorado
534-6308

HONOLULU
841 HALEKAUWILA ST.
506-721

Faster ★ Better ★ More Economically

U. S. MFR'S. WITH WORLD WIDE REPS. (cont'd)

ROCK-OLA

ROCK-OLA MANUFACTURING CORPORATION

800 North Kedzie Ave.
Chicago, Illinois

Foreign Representatives:

Brabo Corporation
Kronenburgstreet 55
Antwerp, Belgium
Tel: 37.99.82
Cable: "Tablichar"
George Charlier
A. den Ouden
Gerry Linssen

(Rock-Ola
Kon. Astridplein 2-3
Antwerp, Belgium)

Brabo Corporation
Carel Reinierskade 53
Den Haag, Netherlands
(Belgium, Luxembourg, Netherlands)

Capitol Enterprises
P. O. Box 253
Monrovia, Liberia
West Africa
C. Fairhurst, General Manager

Compania Comercial Curacao de Honduras, S.A.
Apartado 353
Tegucigalpa, Honduras
Cable: Curtrading
Rudy Van Ammers, Mgr.
W. Olyslager

P. O. Box 62
San Pedro Sula, Honduras

Companhia Ultramarina de Comercio, Lda. (See Walker Bros.)
Avenida Da Republica No. 27
Lourenco Marques, Portuguese East

Curacao Trading Co. Inc.
120 Wall Street
New York 5, New York
Tel. HA 5-5454
Joseph Wortman

Duarte International Sales Co.2I
835 East 31st Street
Los Angeles 11, California
Tel: Adams 4-9616
Cable: Pacami
J. S. Duarte

Esteve International Corp.
Ponce de Leon No. 724
Hato Rey, Puerto Rico

Goddard Novelty Co. Pty. Ltd.
257 Broadway
Sydney, Australia
Tel: NW 1250 JJ5289
Cable: Goddardnov
H. P. Goddard

Guam Music, Inc.
Blake Bldg.
P. O. Box 631
Agana, Guam
Cable: GMI
Walter M. Dale, Gen. Mgr.

Isthmian Amusement Corporation
P. O. Box 465
Curundu, Canal Zone
George G. Dilfer

K. I. D. Inc.,
Knickerbocker Industries
395 Broadway
New York 13, New York
Tel: Worth 6-2595
B. B. Gechtman
Jules Pressner
Miss Carmen Rivera
(Venezuela, Windward & Leeward Islands, Netherland Antilles)

Laniel Amusement Inc.
151 Rockland Road
Town of Mount Royal
Montreal 16, Quebec, Canada
Phone: 731-8571
Edouard Laniel, President
Gaetan Laniel, Vice-President
Romeo Laniel, Treasurer
Pierre Laniel, Secretary
Jean Coutu

J. Hilhem & Sons
P. O. Box 20
24 Easy Street
Freetown, Sierre Leone
Tel: 2867-2869
Cable: "Wilhem" Freetown

Morcoin Co., Ltd.
564 Interior-1
Echague Street
Manila, Philippines
Wh. J. Suter

New-Way Sales Company
1257-61 Queen St. W.,
Toronto, Ontario, Canada
Phone: 531-9740
Jerry Janda
Paul Janda
Jerry Janda, Jr.

Nova Apparate
24 Semperstrasse
Hamburg 39, Germany
Tel: 27.1221/24
Cable: "Novatrade"
A. W. Adickes
H. Regener, Kurt Borrassch
Adolf Zimmerman
Mr. Vallentin
(Germany, Austria, Italy, Switzerland, Scandinavia, England, France, Portugal, Norway, Denmark, Sweden, Ireland, Spain, Greece, Iceland, Cyprus, Canary Islands, French Somililand, Ethiopia)

(Novomat A. G.
Pfeffingerstr. 104
Basel, Switzerland
G. Guldenschuh
G. Jeker)

(Grommer & Co.,
Taborstreet 25
Vienna II, Austria
Grommer—Spirkl)

(Mepadi S. A.
Rue de La Grange Aux Ormes
Marly-Haute Par Metz
Boîte Postale No. 191
France
Mr. Caen, Mr. Loewe)

(Ruffler & Walker
33-37 St. John's Hill
Clapham Junction
London S. W. 11, England
W. R. Ruffler
F. Gordon Walker

(Bruno Dragoni
via Ugolini 12
Milano, Italy)

(British Automatic Co.
14, Appold Street
London E. C. 2, England
Mr. Cooper
Mr. J. Rendell)

Nova's Forwarder:
Judson Sheldon International
161 Avenue Of The Americas
New York, New York 10013
Tel: Digbey 9-3500
E. H. Luhmann

Pakistan Radio House, Ltd.
27, Victoria Road
P. O. Box 7234
Karachi, Pakistan
Tel: 52900 or 52347
Cable: "Parahouse"

STRUVE DISTRIBUTING CO.

"Covers The West"



Struve Distributing also covers the world with the finest used equipment for export.

Contact us for your needs.
All equipment shipped to your specifications.

Cable address: KLEACOE
Los Angeles

With quality equipment
and better service.

Exclusive distributors for:

**SEEBURG
UNITED
WILLIAMS**

Offices:

Struve Distributing Co.

★ 50 Rio Grande Blvd.
Denver, Colorado
303-222-9758

★ 1902 E. McDowell
Phoenix, Arizona
602-253-9544

★ 1403 W. Pico Blvd.
Los Angeles, California
213-748-8641

★ 963 Folsom Ave.
Salt Lake City, Utah
801-328-1541



TAITO TRADING Co., Ltd.

Head Office

206-8 Fukoku Bldg., Uchisaiwai-cho, Chiyoda-ku, Tokyo, Japan

JAPAN'S LEADING DISTRIBUTORS AND IMPORTERS OF JUKE BOX-COIN MACHINES AMUSEMENT MACHINES OF ALL KINDS



SOLE DISTRIBUTORS
FOR JAPAN

**SEEBURG
GOTTLIEB
SCOPITONE**



EXCLUSIVE EXPORTERS
OF

**CONTINENTAL
FRUIT MACHINE**

WORLDWIDE ENQUIRY
WELCOMED

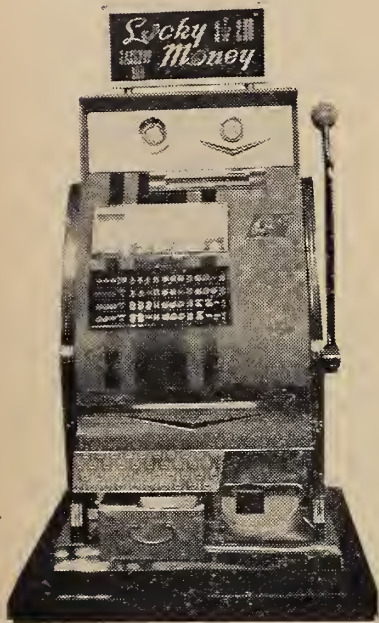

BEST WISHES TO CASH BOX from WISCONSIN & MINNESOTA'S BUSIEST DISTRIBUTORS

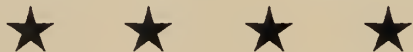

Joel Kleiman Sam Cooper

Kenny & John Glenn

PIONEER

SALES & SERVICES, INC.
3110 W. Fond Du Lac
Milwaukee, Wisconsin
Phone: HI. 5-9340

K C

SALES & SERVICES
1926 University Ave.
St. Paul, Minn.
Phone: 645-9184

"FROM PORT OF BOSTON TO YOU"

TRIMOUNT

*A New England Firm
with a Worldwide
Reputation!*

Celebrating 41 Years
Of Service To The Trade.
Specializing In the
EXPORT MARKET.
Contact TRIMOUNT
for your Monthly Bulletin
and Complete Price List.

Cable: TRICOIN, Boston

TRIMOUNT AUTOMATIC SALES CORP.

Branch of Rowe AC Service Division of Automatic Canteen Company of America
40 Waltham Street, Boston 18, Mass.
Tel. Liberty 2-9480, Cable: Tricoin, Boston



U. S. MANUFACTURERS

with

WORLD WIDE REPRESENTATIVES

(Rock-Ola continued)

vs: Gimbles Store
Summerset Street, Saddar
Karachi 3, West Pakistan
Mr. H. A. Karim Issa

W. E. van Romondt's Handel
Maatschappij N.V.
Postbus 168
Paramaribo, Surinam Z.A.M.
Netherlands Guiana
Tel: 2831, 2832
Cable: "Vanromondt"
H. C. H. Jongbaw

Ross Distributors of Puerto Rico,
Inc.
215 Eleanor Roosevelt Avenue
Hato Rey, Puerto Rico

Nippon Goraku Bussan K. K.
Tokyo International Airport
Haneda P. O. Box 63
Tokyo, Japan
Cable: "Utamatik Tokyo"
Richard D. Stewart
Paul Yuan
(Japan)

Establishment Garlan
International P. O. Box 1252
Seoul, Korea
Cable: "Egarlan"
A. P. Kolonie
Wayne A. Perryman (Korea)

American Vendors, Inc.
P. O. Box 238
Naha, Okinawa
Cable: "Amvendo"
Tel: 899-2162
K. Takaesu
Frank Pontillo

Club Specialty Inc.,
Apartado 133
Panama, R. de Panama
Alfredo E. Reynolds
Gande, Price, Ltd.,
G. P. O. Box 2621,
Gloucester Bldg.
Hong Kong (Room 324)
Cable: "Tradewell Hong Kong"
Phone: 22284
A. A. Smith
(For S. E. Asia—U. S. Military
market)

Wh. J. Crum
Gande, Price, Ltd.
Boite Postale 872
Saigon, Vietnam

Juke-Boxes Inc.
119B Chatham Road, 7/Floor
Kowloon, Hong Kong
Cable: "Jukeboxes Hongkong"
Tel: 67643
Mr. John G. Perrone
(S. E. Asia—Civilian Market)

Pacific Entertainments Ltd.
Rm. 228 Wang Hing Building
#10 Queen's Road Central
Hong Kong
Cable: "Pelimited"
Tel: 27735/6/7
S. Stevenson
(Taiwan)

Sega, Inc.
Haneda Airport
P. O. Box 32
Tokyo, Japan
Tel: (741) 9261
Cable: "Segastar"
S. F. Dotterer, General Manager

Mr. Leo Prescott
Roof Garden Offices
Hotel Filipinas
Dewey Boulevard, Manila
Philippine Islands
Cable: "Leoprest Manila"
Phone: 5-70-11 office
8-63-75 home
(Philippine Islands)

Service Games Inc., Panama
Apartado 133
Panama, R. de Panama
Cable: "Servgame"
Tel: 3-1590
L. O. D'Aquino

Whitney I. Crum
Tradewell Enterprises
suite 104
14106 Ventura Blvd.
Sherman Oaks, Calif. 91403

Robbins Forwarding Co.
327 S. La Salle Street
Chicago, Illinois
F. J. Franklin
Mrs. M. Wessig

Syeeda Tallim
175 Waterloo Street
Georgetown, British Guianan
S. Tallim

Van Dusen Brothers
10528-123rd Street
Edmonton, Alberta, Canada
Tel: Hunter 8-0040
Wesley Van Dusen
E. Alex Bendera

(Van Dusen Brothers
723-10th Avenue, S. W.
Calgary, Alberta, Canada
Tel: 5-5452

(Select Music Company
428 West 8th Avenue
Vancouver 10, B. C., Canada
Tel: 874-2362

Walker Brothers (London)
Limited
Salisbury House
London Wall
London, E.C. 2, England

Raymond Weir
Regent Street West
Belize, British Honduras

Winnipeg Coin Machine Co.,
768 Notre Dame Avenue
Winnipeg, Man., Canada
Tel: SP 2-2429
Roman Kozoris

ROWE AC

ROWE AC MANUFACTURING

Troy Hills Rd.
Whippany, New Jersey

DISTRIBUTORS and LICENSEES

AUSTRIA

Franz A. Szechenyi
Automaten und Schallplattenban-
del
Franz Josef Kai 63
Vienna, Austria

BELGIUM

Ets. C. Van Brabant
Belgielei 134
Antwerp, Belgium
Cable: TONALTY

DENMARK

Oscar Siesbye A/S
5, Palaisgade
Copenhagen K, Denmark
Cable: SKES

ENGLAND

Automatic Canteen Co. (G.B.)
Ltd.
616, Spur Road
North Feltham Trading Estate
Feltham-Middlesex, England
Cable: CANTEEN-HOUNSLOW-
MIDDLESEX

Continued on page 18)

30



ALFRED ADICKES



GRAND PRIX II
Model 426 160-selections
Stereo-monaural 45-33 rpm

YEARS of HAPPINESS and SUCCESS THROUGH MUTUAL COOPERATION!

It has been approximately 30 years since Rock-Ola began producing phonographs at the famous address in Chicago—800 North Kedzie Avenue—an international landmark today. It is more than 30 years ago since the mutually successful and very pleasant relationship started between NOVA APPARATE and ROCK-OLA MANUFACTURING CORPORATION.

We are happy to congratulate Mr. David C. Rockola and the entire Rock-Ola organization on 30 wonderful years in business.

Unprecedented sales results on Rock-Ola products throughout Europe support the wisdom in joint planning between U.S. manufacturer and European distributor. The "Grand Prix II," "Starlet," "Princess Royal" and "Wall Phonograph" models are the stars of this gala anniversary year. This program meets the most stringent requirements and the most discerning tastes.

We shall continue to provide the trade with surprises and innovations in coin-operated equipment through the years with Rock-Ola products now on the drawing boards. Rock-Ola phonographs excel in full dimensional tone reproduction, technical perfection, and beautiful styling.

Rock-Ola phonographs means better phonographs—better music! That's what our customers want . . . that is what NOVA APPARATE and ROCK-OLA will continue to give them!



STARLET
Model 429 Compact 100-
selections Stereo-monaural
45-33 rpm



PRINCESS ROYAL
Model 424 High fashion 100-
selections Stereo-monaural
45-33 rpm

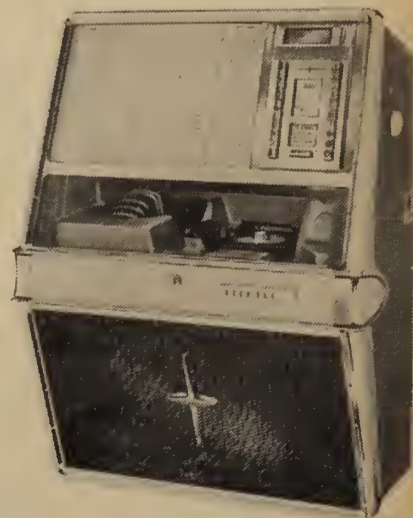

WALL PHONOGRAPH
Model 403 100-Selections
Stereo-monaural compact 33-
45 speed

PLUS . . .
Rock-Ola's PHONETTE WALL BOX
Model 500 160-sel; Model 501 100-
sel. Twin stereo speakers, volume
controls, 45-33 rpm

NOVA APPARATE

24, Semperstrasse Hamburg 39 Germany

U. S. MFR'S. WITH WORLD WIDE REPS. (cont'd)

(Rowe AC continued)

Automatic Canteen Co. (G.B.)
Ltd.
Sun Mill, Peel Street
Chadderton, Near Oldham
Lancashire, England
Cable: CANTEEN-CHADDER-
TON

Automatic Canteen Co. (G.B.)
Ltd.
590-594 Wandsworth Road
London S. W. 8, England

FRANCE

Electronique et Mecanique
175 bis, Blvd. Jean Jaures
Boulogne, Billencourt (Seine)
Paris, France

GERMANY

Helmut Rehbock, GmbH
Alter Teichweg 19
Hamburg 22, Germany
Cable: HELREHBOCK

GREECE

Tecnophon Import Export Co.
Ltd.
135 Patission
Athens, Greece
Cable: TENOAMI

HOLLAND

Theo A. Denies
Nieuwe Havenstraat 97
The Hague, Holland

IRELAND

Renters Ltd.
23 Exchequer St.
Dublin, Ireland

ITALY

S. p. A. Microtecnica (L)
147 Via Madama Cristina
Torino, Italy
Cable: MICROTECNICA

Apparecchi Musicali Italiani
Corso Unione Sovietica 28
Torino, Italy
Cable: AMUSIT

MALTA

Jos. Micallef (1919) Ltd.
34 Strait Street
Valletta, Malta
Cable: MICALLECO

NORWAY

A/S Frigoterm
5-7 Grensen
Oslo, Norway
Cable: FRIGOTERM

PORTUGAL

C. O. Husum
Rua Da Madalena 18-4
P. O. Box 2683—Central
Lisbon, Portugal
Cable: FLAMINGO

SWEDEN

Canteen Automatfoersaeljning
AB
Elektravagen 49
Postbox 42016
Stockholm 42, Sweden
Cable: CANTEEN—STOCK-
HOLM

SWITZERLAND

Automatic Musical Instruments,
S. A.
25, route des Acacias (Sales Of-
fice)
Geneva, Switzerland
Cable: AMINC
Cortina Automaten, A. G.
Solothurnerstrasse 91
Basel, Switzerland
Cable: CORTINA
René Aubert
Chemin du Levant
Lausanne, Switzerland

MIDDLE EAST

CYPRUS

George Heraclides
64-65 Athens Street
Larnaca, Cyprus

IRAN

Sherkat Bazargani Zereh
(Zereh Trading Co. Ltd.)
646 Saadi Avenue
Tehran, Iran
Cable: ZEREHCO

LEBANON

Wael & Wissam Ezzedine
P. O. Box 157—Allenby St.
Beirut, Lebanon
Cable: EZZE

SYRIA

Mohammed Kheir Kabbani
P. O. Box 1066
Damascus, Syria

AFRICA

TUNISIA

Marcel Bellaiche
2 Rue de Nice
Tunis, Tunisia

FAR EAST

Hirdaramani, Ltd.
65-69 Chatham Street
P. O. Box 324
Colombo, 1, Ceylon
Cable: HIRDARAM

JAPAN

Tsugami Mfg. Co. Ltd.
4-1 Tamura-cho Shiba
Minato-ku
Tokyo, Japan
Cable: TSUGAMI

GUAM

A. J. Shelton
P. O. Box 803
Agana, Guam

AUSTRALIA

National Instruments, Pty. Ltd.
(L)
Phillips Road
Kogarah, N. S. W., Australia
Cable: NATAMI—SYDNEY

LATIN AMERICA AND THE CA- RIBBEAN AREA

ARGENTINA

Vicente Sirimarco
Distribución A M I
Av. Corrientes 758—2o. D
Buenos Aires, Argentina

BAHAMAS

Carter's Upholstering Works
P. O. Box 934
Augusta & South Sts.
Nassau, N.P., Bahamas

BRITISH GUIANA

Eclipse Agencies
9 Longden St.
Georgetown, British Guiana

CHILE

Indelec (Office)
Monjitas 470
Santiago, Chile
Cable: INDELEC
Indelec (Assembly Plant)
Casilla 690
Arica, Chile
Nicolás Chápanos M.
Avda. Independencia #3689
Santiago, Chile

COSTA RICA

Discoteca Ltda.
Apartado 1635
San José, Costa Rica

CURACAO

Ed. & D. A. Haseth
Wolkstraat 12-14
P. O. Box 600
Willemstad
Curacao, Netherland Antilles

DOMINICAN REPUBLIC

Curacao Trading Co., S. A.
P. O. Box 868
Santo Domingo, Dominican Re-
public
Cable: CURTRADING

(Continued on following page)

ALL POOL TABLE SUPPLIES

UNDER 1 ROOF!

from
one of America's
largest pool table supply
houses catering to the coin machine industry!

● "IMPERIAL CUE STICKS"

Exclusive line of IMPORTED and DOMESTIC cues—in all lengths—48", 52", 57".

Two-piece jointed cues with plain or ultra-fancy butts also available.

These cues are sturdily constructed of the finest woods for professional play and accuracy. Available by the dozen or by the gross.

● SLATES

In ALL sizes! For tables requiring one-piece slates or three-piece slates for larger tables.

● "IMPERIAL" CLOTH

OUR OWN EXCLUSIVE LINE OF IMPORTED QUALITY CLOTH. And available ONLY from Eastern Novelty Distributors, Inc.!

Highest quality . . . rubber-backed with cotton or rayon, or unbacked. Sold by the bolt or pre-cut to any size. Variety of colors always available!

● BALLS

The finest IMPORTED Belgian balls, designed to last a lifetime. Complete sets (1-15), cut balls or odd replacements.



eastern

FULL LINE OF ACCESSORIES
Complete 1965 Catalog Available on Request
Distributor and Manufacturer Inquiries Invited!
NOVELTY DISTRIBUTORS, INC.

3726 Tonnele Avenue
(Routes #1 and #9)
North Bergen, New Jersey
Telephone (201)
UNION 4-2424
Member BBIA

U. S. MFR'S. WITH WORLD WIDE REPS. (cont'd)

(Rowe AC continued)

ECUADOR
Distribuidora Musical, G. A.
"Dimúsica"
Avenida 9 de Octubre No. 909
Apartado 5547
Guayaquil, Ecuador
Cable: DIMUSICA

EL SALVADOR
Distribuidora Eléctrica
Calle Ruben Darío No. 418
San Salvador, El Salvador
Cable: DISTELEC

GUATEMALA
Distribuidora Electro Musical,
S. A.
11 Calle 5-67
Zona 1
Guatemala, Guatemala, C.A.
Cable: DEMSA

HONDURAS
Yude Canahuati
Apartado Postal No. 76
San Pedro Sula, Honduras, C.A.
Cable: YUDE-TEGUCIGALPA

BRITISH HONDURAS
David Estephan H.
P. O. Box 155
Belize, British Honduras

MEXICO
Ami de México, S. A. (L)
Calzada Tlatilco No. 239
México 16, D. F.
Cable: MEXAMI

NICARAGUA
Solorzano Villa Pereira Comercial
S. A.
Avenida Roosevelt No. 202
Managua, Nicaragua
Cable: SOVIPE

PANAMA
Elga, Inc.
Apartado 4395
Panamá, Panamá
Cable: DISELEC

PERU
Panamúsica, S. A.
Avenida 28 de Julio 144
Lima, Perú
Cable: PANAMUSICA

TRINIDAD
Loraine Distributing Company
1B Sea Lots
Port of Spain
Trinidad, B.W.I.
Cable: LORDISCO

URUGUAY
Jesus Lareo
S. C. 8 de Octubre No. 4665
Montevideo, Uruguay
Cable: JELA

VENEZUELA
Distribuidora Jasalco, C. A.
Apartado 2607
Caracas, Venezuela
Cable: JASALCO

Casa Lujan, S. A.
Maderero a Bucara #148
Caracas, Venezuela
Cable: LUJANER

Distribuidora Cestari
Calle Libertad, 36
Apartado No. 4250
Puerto La Cruz, Venezuela
Cable: CESTARI

Emarven, C. A.
Apartado del Este 5635
Caracas, Venezuela
Cable: EMARE

Arturo Ehrlich
Calle Comercio 97
Valencia, Venezuela

Mercantil Lara, S. A.
Apartado Postal 291
Carrera 21 #25-81
Barquisimeto, Venezuela
Cable: MERCALA

Unión Mercantil Pacheco, C. A.
Apartado No. 75
Valera, Edo. Trujillo
Venezuela
Cable: UMPACA

(L) Indicates that firm is a Rowe-AC licensee

SEEBURG
SEEBURG INTERNATIONAL INC.
1500 N. Dayton St.
Chicago, Illinois

Seeben, N. V.
203 Mechelsesteenweg
Antwerpen, Belgium

Seeburg Great Britain Ltd.
430 Edgeware Road
London W. 2, England

Seevend Automaten Vertriebs,
G.M.B.H.
Fuhlsbuttler Strasse 108
(Drosselhof)

Hamburg 33, Germany
Seerome S.P.A.
Viale Lombardia 72
Milan, Italy

Seerome S.P.A.
Via Gadames 44-46
Rome, Italy

A & D Christoff O. H. G.
Stubenring 16
Vienna 1, Austria

Nordatoy Oy
Sahaajank 7
Helsinki, Finland

Socodimex S. A.
1, Quai de Grenelle
Paris 15, France

General Espanola de Automaticos
S. A.
Calle Valderribas 73
Madrid 7, Spain

Manufacturera de Sinfonolas
S. A.
Avenida Jardin 330
Mexico 15, D. F., Mexico

Philippine Amusement
Enterprises
P. O. Box 2952
Manila, Philippines

Musikvertrieb A. G.
Badenerstrasse 555
Zurich, Switzerland

Distribuidoras Unidas C. A.
Avenida Mexico No. 229
Caracas, Venezuela

Taito Trading Co., Ltd.
Central P. O. Box 1164
Tokyo, Japan

Pan Nordic Automation
P. O. Box 18
Saro, Sweden

Mr. Peter Thomas
Avenida Universitaria
San Salvador, El Salvador

Seeburg Automatic Products
Pty., Ltd.
Lido House
400 Kent Street
Sydney, Australia

Seeburg (Aust.) Pty. Ltd.
136 Nelson Street
Annandale, Sydney, Australia

(Continued on following page)

★ **WE EXPORT** ★

LET US KNOW
WHAT YOU CAN USE!

WE CAN FURNISH
MOST ANYTHING YOU WANT
IN TOP CONDITION!

OUR FIRM FORMERLY MADE SHIPMENTS
FROM CINCINNATI, OHIO BY JOE WEINBERGER

— **WRITE** —

SOUTHERN AUTOMATIC MUSIC COMPANY

735 SOUTH BROOK STREET • LOUISVILLE, KENTUCKY • PHONE JU 5-5094

State Sales and Service Corporation

SAMUEL A. WEISMAN
1825 GUILFORD AVENUE

Phones: 837-7177

DAVID KOENIGSBERG
BALTIMORE 2, MD.

THE WURLITZER COMPANY

BALLY MFG. CO.
MIDWAY MFG. CO.
TAPE-ATHON CORP.

EXCLUSIVE
FACTORY
DISTRIBUTORS

IRVING KAYE SALES CORP.
UNIVERSAL VENDORS, INC.

DITCHBURN VENDING MACHINES, INC.
AUTOMATIC PRODUCTS CO.
CHICAGO DYNAMIC INDUSTRIES, INC.

ATTENTION: WORLD BUYERS:

OUR LARGE VOLUME OF SALES FOR THE WORLD'S
FINEST MANUFACTURERS BRING US QUANTITIES OF
LOVINGLY USED MONEY-MAKING COIN OPERATED
EQUIPMENT.

WE ARE EXPERTS IN RECONDITIONING, CRATING AND
SHIPPING TO ALL PARTS OF THE WORLD FROM THE
GREAT PORT OF BALTIMORE.

TRY US FOR PRICE

TRY US FOR QUALITY

- Bingo Games
- Shuffle Alleys
- Bowling Alleys
- Arcade Equipment
- Phonographs
- Pin Ball Machines
- Cigarette Machines

Satisfaction Guaranteed



CABLE ADDRESS
STASA

U. S. MANUFACTURERS with WORLD WIDE REPRESENTATIVES

Stockdales Industrial Vendors
Limited
Heacham, King's Lynn
Norfolk, England

Codiscos-Compania Colombiana
De Discos S. A.
Apartado Aereo No. 14-28
Nebellin, Colombia

Cable address for Seeburg
International is SEEVEND CHICAGO

Pizarro, Forttes & Cia. Ltda.
Casila No. 250
Vina del Mar, Chile

Disco Centro Ltda.
Apartado #52
San Jose, Costa Rica

Caribbean Motors Co., C. Por A.
Apartado #52
Santo Domingo, Dominican
Republic

A.M.I.C.A.
Apartado 1052
Calle Benalcazar No. 511
Quito, Ecuador

Casa Edison
9a, Av. Sur y Calle Ruben Dario
606
San Salvador, El Salvador

N.A.M. Nacional
P. O. Box 196
6a. Ave. y 24 Calle, Zona 4
Guatemala, Guatemala

Curacao Trading Co., Inc.
P. O. Box 368
Port-au-Prince, Haiti

Cosdel (H.K.) Ltd.
Man Yee Bldg. Des Voeux Rd.
P. O. Box 2567
Hong Kong

Juke Box Ltd.
144 King Street
Kingston, Jamaica

(Continued on following page)

WILLIAMS

WILLIAMS ELECTRONIC
MANUFACTURING CORPORATION
3401 North California Ave.
Chicago 24, Illinois
(Division of Seeburg)

WURLITZER

Community Furniture Store
P. O. Box 483
Bay Street
Nassau, N.P., Bahamas

The Auto Supplies Co.
30, Hadfield and Lombard Sts.
Georgetown, Br. Guiana

Santiago Castillo, Ltd.
P. O. Box 69
Belize, Br. Honduras

LIEBERMAN MUSIC CO.

257 Plymouth Ave. North
Minneapolis, Minnesota

Exclusive Factory Distributors

(612) 332-7131

SEEBURG SALES CORP.
BALLY MFG. CO.
D. GOTTLIEB & CO.
FISCHER SALES & MFG. CO.
WILLIAMS ELECTRONIC MFG. CORP.

5 ONE-STOPS TO SERVE YOU

ACME MUSIC CO.

Sam Sales

321 Plymouth Ave., North
Minneapolis, Minnesota

(612) 332-7131

LIEBERMAN-IOWA ONE-STOP

1406 E. Grand Ave.
Des Moines, Iowa

(515) 262-8211

LIEBERMAN'S ONE-STOP RECORDS

809 So. 25th St.
Omaha, Nebraska

(402) 341-3056

MUSIC BOX ONE STOP

1301 W. 79th St.
Chicago, Ill.

(312) A8. 4-3600

VAN GORR'S ONE STOP

1715 Second Ave.
Rock Island, Ill.

(309) 788-3401

VIKING VENDING CO.

257 Plymouth Ave., North
Minneapolis, Minnesota

(612) 332-7131

SEEBURG VENDING MACHINES
CONEX CUPS
Full Line Vending Machine Parts

HAROLD N. LIEBERMAN CO.

FE 2-3336

Exclusive Distributor For
The Following Record Mfrs.:

ABC PARAMOUNT
BEAR
CAMEO-PARKWAY
DOT
FOUR CORNERS
KAPP
LONDON & GROUP
MGM
MONUMENT
SWAN
VANGUARD
VERVE

EUROPE'S LARGEST DISTRIBUTORS OF PLEASURE PRODUCTS



33-37, ST. JOHN'S HILL, CLAPHAM JUNCTION, LONDON, S.W.11.

WORKS, ALTENBURG GARDENS, S.W.11.

TELEPHONE BATTERSEA 8626-7-8-9 CABLES RUFFWALK LONDON

IMPORTERS AND SOLE U.K. DISTRIBUTORS OF THE WORLD FAMOUS

ROCK-OLA

for reliability

MAIN U.K. DISTRIBUTORS SEGA FRUIT MACHINES

WE ALSO CARRY A FULL RANGE OF

JENNINGS - KEENEY - GAMES - GOTTLIEB - CHICAGO COIN PRODUCTS

WISCONSIN'S LEADING DISTRIBUTOR

Celebrating our 26th Year

SPECIALIZING (EXPORT & DOMESTIC MARKETS)

Buying—Selling—Trading

New and used phonograph-games

Exclusive distributors for Wisconsin and Upper Michigan

THE WURLITZER COMPANY (Phonographs) ALL-TECH (Pool Tables)

VALLEY SALES COMPANY (Pool Tables) UNIVERSAL VEND (Candimat)

TAPE-ATHON CORP. (Background Music) STANRAFT (Merchandise Vendors)

DITCHBURN VENDING (Vending Machines)

Write for current price lists (EXPORT & DOMESTIC) or call
for the best deal Area Code 414

HARRY JACOBS, PRES.



united Inc.

1907 N. Third St., Milwaukee, Wis.
53212 Phone 372-9272

U. S. MFR'S. WITH WORLD WIDE REPS. (cont'd)

(Wurlitzer continued)

Matsushita Electric Trading Co., Ltd.
Kawaramachi Bldg.
71, 5-chome, Kawaramachi,
Higashi-ku
Osaka, Japan

Matsushita Electric Trading Co., Ltd.
15-17, Shinbashi 6-chome,
Minato-ku
Tokyo, Japan

Industrias Riojas, S.A.
Rosas Moreno 97
Mexico 4, D.F., Mexico

Daniel Genest
755 Montfort
Jonquiere, Que., Canada

Monarch Coin Machine Company
211 Rupert Avenue
Winnipeg, Man., Canada

William Pound Agencies Ltd.
P. O. Box 1173
St. John's, Nfld.

C. J. Sheils Ltd.
1760 Midland Avenue
Scarborough, Ont., Canada

Deutsche Wurlitzer GmbH
Hullhorst, Kreiss
Lubbecke/Westf.
Germany
"Covering the European Market
& North Africa"

Mid-West Distributors
709 Linwood Boulevard
Kansas City 9, Missouri
816 Westport 1-8776
J. W. Balk, President

Curacao Trading Co., S.A.
P. O. Box 308
Curacao, N.W.I.

J. A. Nieuw
P. O. Box 84
Oranjestad, Aruba, N.W.I.

Williams International, Inc.
Central P.O. Box 164
Naha, Okinawa

Guardia & Cia., S.A.
Apartado Postal 481
Panama City, Panama

Importaciones Peru Ltda.
Av. Limatambo 3589, San Isidro
Apartado de Correos 4124
Lima, Peru

Borinquen Music Corporation
Calle Comercio 400
P.O. Box 3089
San Juan, Puerto Rico

Trinidad Phonograph Co., Ltd.
P.O. Box 859
54 Park Street
Port of Spain, Trinidad
Elias V. Siutto
Y1 1599
Montevideo, Uruguay

Comercial Jaeger, S.A.
La Casa del Radio
Apartado 228
Maracaibo, Venezuela

Intervencia
Calle Real de Savria
Apartado del Este 5125
Caracas, Venezuela

Houette Amusement Company
1807 Notre Dame St., W
Montreal 3, Que., Canada

Dale Distributing (B.C.) Ltd.
1110 Homer Street
Vancouver 2, B.C., Canada



Shipments made all over the world—No Inland Freight
"As Is" or Re-Conditioned
Special Chutes—Special Packing—We Service What We Sell
Write for Complete Catalog

NOW AVAILABLE
Bowlers/Shuffles/Gottlieb & Williams Five Balls

PHONOGRAPH SPECIALS:
Wurlitzer 1800/1900/2000/2100/2300
Rock-Ola 1448/1455/1454/1468/1475
AMI G200/G120/H200/I200/I120/J200/J120
Seeburg B-C/G/R/V200/K200



EMPIRE INTERNATIONAL

DIVISION OF EMPIRE COIN MACHINE EXCHANGE, INC.

Chicago: 1012 N. Milwaukee EVerglade 4-2600
Detroit: 7743 Puritan Diamond 1-5800
Call—Write—Cable for Prices Cable **EMCOMACH**

Domestic Distributors for Rock-Ola • Midway • Pool Tables by Fischer



"You've tried the rest . . . now play the best"



FISCHER . . . THE BEAUTIFUL TABLES

with the big, profitable difference in performance

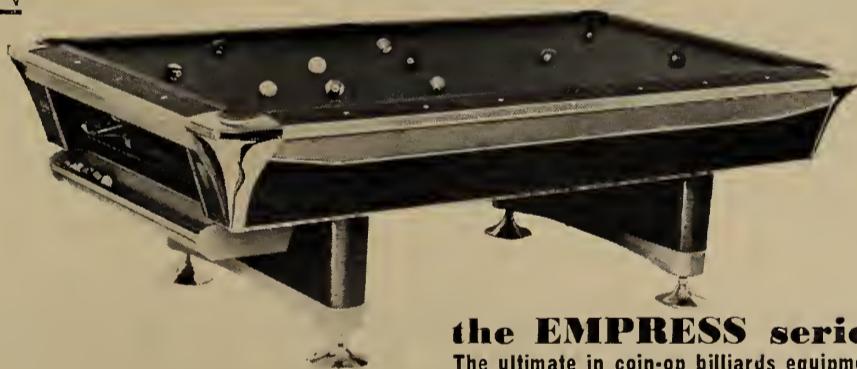

the EMPRESS series
The ultimate in coin-op billiards equipment.
Luxuriously styled . . . precision crafted
. . . designed to give years of use.

Cue ball at opposite end of table from coin-op mechanism, new heavy die-cast chrome-plated corner sections, bolt down top frame, all metal non-clog open center runways, inlaid diamond markers on burnproof top rail, heavy die-cast leg levelers and chrome-plated shields, covering of the very finest All Wool felt.



Pat. Pending.



Provides faster ball action, faster easier set-up, quicker easier cushion replacement.

12 unit-lock clamps replace more than 50 wood screws . . . Wedge-lock locks cushions, top rail, playfield and frame together in a single, perfectly fitted rigid unit.

- Precision ground marble playfield, guaranteed not to warp for life of table (also available, slate playfield).

- 101" or 92" in Walnut-grained formica or mahogany-look Duran Clad-on.

See your Distributor or write

by *Fischer*

MANUFACTURING CO., INC.
TIPTON, MO.

When you think billiards . . . think FISCHER—that's quality!

Proved in use for over 15 years



REGENT SERIES

Compact companion to the Empress line. Mahogany-look Duran Clad-on finish, chrome-plated cast pocket fittings, patented Wedge-Lock and cushion assembly. Choice of sizes:
REGENT—91-A 92"x52"x31½"
REGENT—71-A 71"x45"x31½"



FIESTA 58 Bumper Table

Top dollar returns per square foot. Quality features throughout: removable top frame, metal bumpers, separate cash box, recessed pull-out drawer mechanism, chrome corners, top quality balls, superior quality cloth, no-lift leg levelers. Durable mahogany-look Duran Clad-on. Regulation size, 41 3/16"x57 3/16"x32½".

Coin-Operated MOVIES

MODEL AP-10

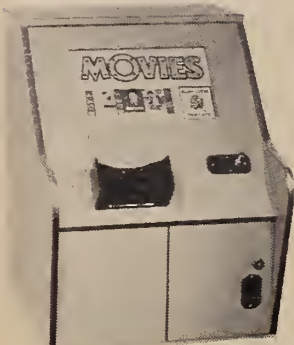

WT. 54 lbs.
Stands Available

MODEL KKT



"WITH SOUND" & ALL
FILM IN COLOR"

MODEL AD PANORAM
formica
covered



Complete Film Library

MODEL AP-10 CONSOLE
WT. 80 lbs.



For Complete Information,
Write or Call

Manufactured by:

urban

Industries Inc.
P.O. Box 31
Louisville, Kentucky 40201
Phone: AC 502-583-8059

HARBY

HAS THE BIG MONEY MODELS THAT EARN BONUS PROFITS!

Pictured at right is the New KOMPAK-4 UNIT. Combines 4 Bulk Vendor into one unit. Secured by Ace Lock. Lever Action provides direct access to any unit desired without disturbing adjacent unit.

Also Manufactured in Single Units—One Complete Machine.

Other Top Quality Vending Combinations by HARBY Include:

BALL GUM
CAPSULES

NOVELTIES
WRAPPED GUM

ANY COIN DENOMINATION OR ANY MERCHANDISE DISPENSER AT NO EXTRA CHARGE.

Write for Complete Catalog:

HARBY INDUSTRIES

702 Mariposa, Burbank, Calif.

Exclusive European Dist. Holland Belgie, Europe 276 Ave. Louise, Brussels 5, Belgium



When It Comes To Reconditioned Equipment
Operators always come to

THE LIPSKY DISTRIBUTORS CORP.

607 Tenth Ave., New York, N.Y. • LO 3-4028

All types of new and used Pool Tables • Exclusive N.Y. Distributor of Th. Berman's new "Arizona" Gun.



LOOK to the GENERAL for LEADERSHIP

One of America's oldest and largest coin machine distributors.
Established 1925 — over 41 years of superior service.

Franchised Factory Distributors in
Md.—D. C.—Va.
for

Rockola—Gottlieb—Fischer—Mutoscope
and other leading manufacturers

We export reconditioned equipment of every type
to all the World from the Port of Baltimore

General Vending Sales Corp.

237-245 W. Biddle St.

Baltimore, Md. - 21201

Phones—(Area Code 301) 837-4119

Cable Address—GENVEND

SEGA ENTERPRISES FORMED IN TOKYO

TOKYO—A merger was announced last week between two major leisure recreational equipment industry firms, Nippon Goraku Bussan and Rosen Enterprises Ltd. The name of the company was changed on July 15th to "Sega Enterprises Ltd." the date the merger was officially registered. Richard Stewart, former president of Nippon Goraku Bussan was appointed Chairman of the Board.

David Rosen, former President of Rosen Enterprises Ltd., not to be confused with David Rosen of Philadelphia, was appointed Co-Representative Director as was Mr. Scott F. Dotterer, who was Managing Director of Nippon Goraku Bussan K.K. Both of the companies forming Sega Enterprises Ltd. have shown extremely rapid growth rate over the past several years. Their combined annual sales before the merger amounted to \$8,000,000 annually with a net profit of over \$1,000,000. It is expected that sales and profits will rise appreciably as a result of the better utilization of management personnel and service facilities.

Sega Enterprises will continue to expand in the fields the merged partners pioneered in Japan—the import-export, manufacture, sale and operation of amusement machines, jukeboxes, recreational equipment, model car racing circuits, and other indoor equipment.

Operating jukeboxes and amusement machines in over 2,500 different locations, the company is probably one of the world's largest in the coin operated amusement and jukebox field. In operation and sales the company controls well over 50% of the market. Present plans call for a growth rate of 20% annually. Sega also manufactures for export several different models of coin operated machines thereby contributing to Japan's foreign exchange earnings.

The former Rosen Enterprises pioneered the operation of game centers and indoor recreational centers in Japan. Working very closely with movie companies and utilizing available space they were able to open game centers in the heart of the amusement districts of the various cities in Japan. Pioneering model car racing in Japan, Rosen Enterprises is responsible for over 50% of the existing centers now operating, officials of the firm contend.

Expansion plans are underway to expand the plant and office site which is presently 100,000 sq. ft. located at the entrance of the Tokyo Haneda Airport highway.

THE OLDEST and LARGEST DISTRIBUTOR

ON THE PACIFIC COAST

Exclusive Distributors for:

SEEBURG CORP.

UNITED MFG. CO.

WILLIAMS MFG. CO.

GOTTLIEB MFG. CO.

CHICAGO COIN

MIDWAY MFG. CO.

IRVING KAYE CO.

We have substantial inventories at all times of:

✓ PHONOGRAPHS

✓ GAMES

✓ BOWLERS

✓ SHUFFLE ALLEYS

✓ ARCADE EQUIPMENT

Write or Wire for Information:

Cable Address: PINGAME

Phone: HEmlock 1-1750

ADVANCE AUTOMATIC SALES CO.

1105 WEST PICO BLVD., LOS ANGELES, CALIF. RI 6-1191

COIN-OPERATED PHONOGRAPHS

ROCK-OLA Mfg. Corp.

800 N. Kedzie Ave.
Chicago, Ill.

1954 — 1965



Rock-Ola 1442
(1954—120 Sel.—45 rpm)



Rock-Ola 1446
(1954—120 Sel.—45 rpm)



Rock-Ola 1448
(1955—120 Sel.—45 rpm)



Rock-Ola 1452
(1956—50 Sel.—45 rpm)



Rock-Ola 1454
(1956—120 Sel.—45 rpm)



Rock-Ola 1455
(1957—200 Sel.—45 rpm)

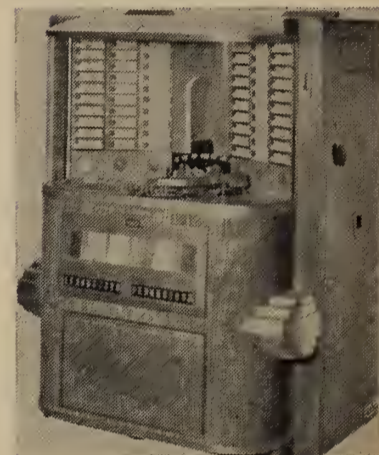

Rock-Ola 1464
(1958—Wall Type Phono)



Rock-Ola 1465
(1958—200 Sel.—45 rpm)
1462—100 Sel., 1458—50 Sel.



Rock-Ola 1475
(1959—St. or Mon. 200 Sel.)
Model 1468—120 Sel.



Rock-Ola 1485
(1960—200 Sel.)
Model 1478—120 Sel.

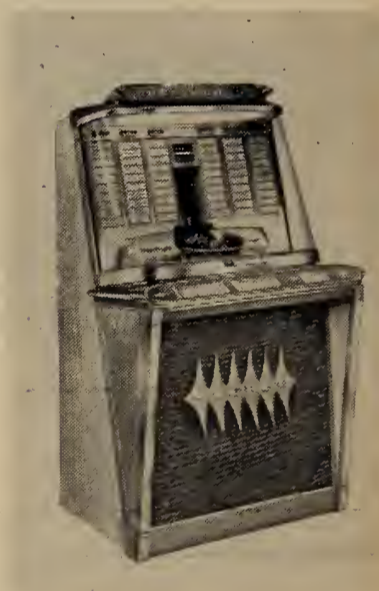

Rock-Ola 1495
(1961—200 Sel.)
Model 1488—120 Sel.



Rock-Ola 1493
(1962 Princess—100 Sel.)
45-33 rpm, and Wall Mdl. Avail.



Rock-Ola 1497
(1962 Empress—200 Sel. 45-33)
Model 1496—120 Sel.



Rock-Ola 408
(1963 Rhapsody—160 Sel.)
Capri-404—100 Sel., 45-33 rpm



Rock-Ola 418 SA
(1964 Rhapsody II—160 Sel.)
Capri-414—100 Sel., 45-33 rpm

COIN-OPERATED PHONOGRAPHS

Rock-Ola —
— Rowe AMI

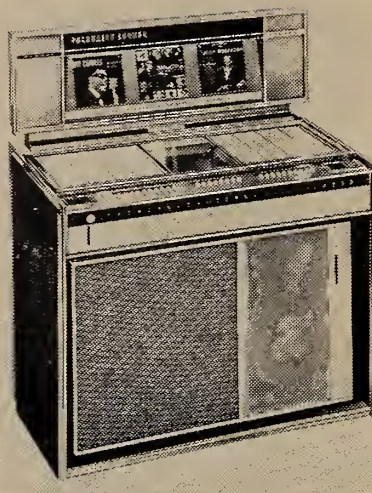

Rock-Ola 424
(1964 Princess Royal St—Mon)
100—Sel. 33—45—7" LP Intermix

Rock-Ola 429
(1965 Starlet St—Mon)
100—Sel. 33—45—7" LP

Rock-Ola 425
(1964 Grand Prix 160—Sel.)
33—45 rpm

Rock-Ola 426
(1965 Grand Prix II 160—Sel.)
St—Mon. 33—45 rpm

ROWE AC MANUFACTURING

Troy Hills Road
Whippany, N. J.

1955 — 1965

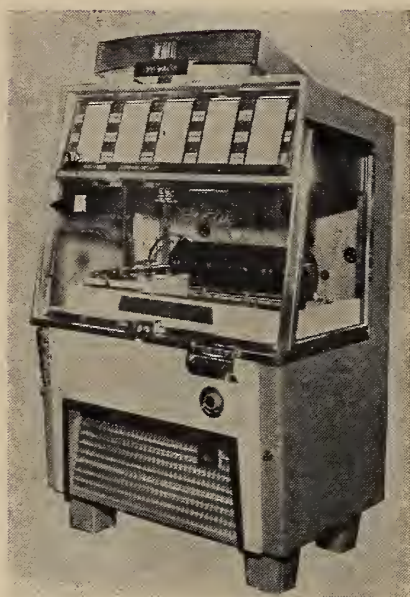

Rowe "G"
(1955 80 or 120—Sel.)
45 rpm

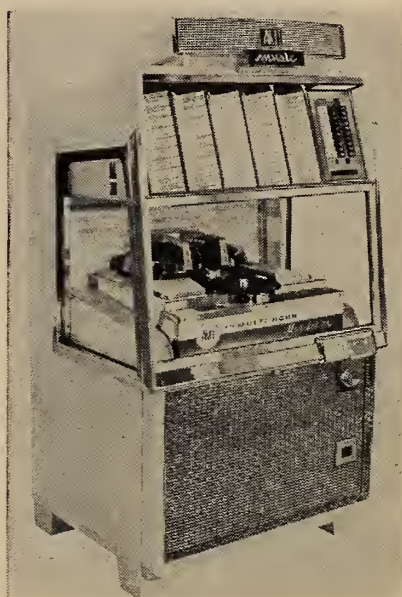

Rowe "G—260"
(1956 260—Sel. 45 rpm)

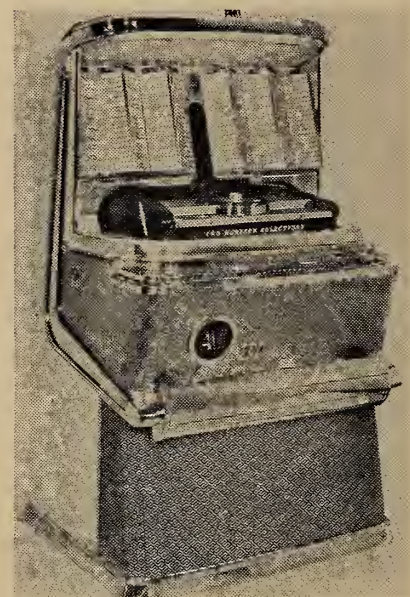

Rowe "H—200"
(1957 200—Sel. 45 rpm)
Model H—120 120 Sel.
(160 Sel. available)

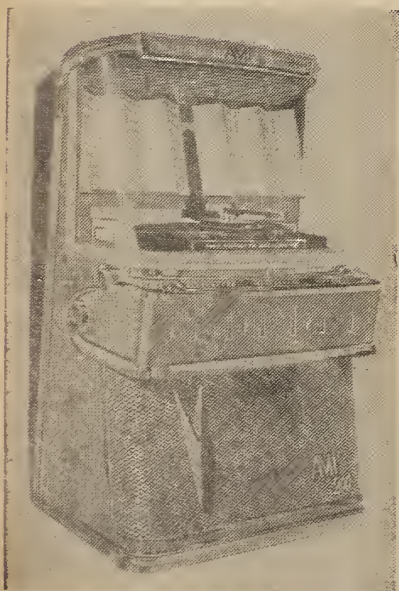

Rowe "1—200"
(1958 200 Sel. 45 rpm)

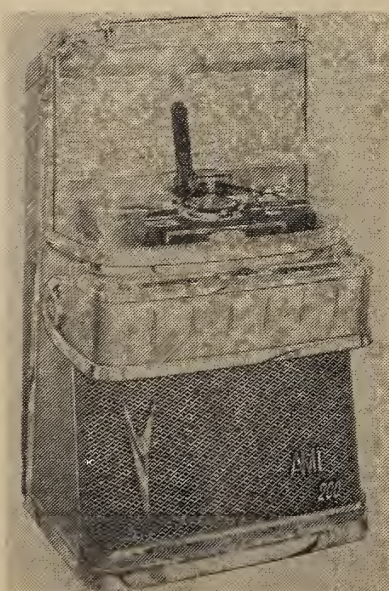

Rowe "1—200M"
(1958 200 Sel. 45 rpm)

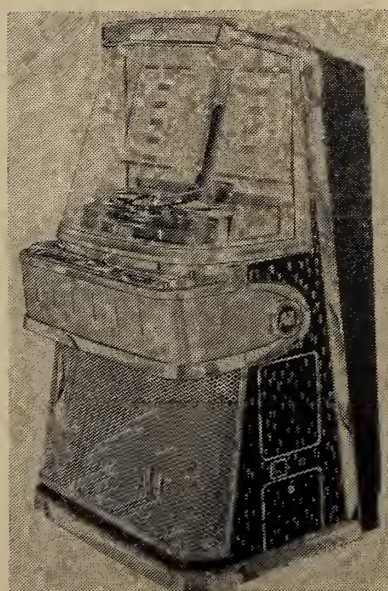

Rowe "1—200"
(1958 120 Sel. 45 rpm)
Model "1—100"
(1958 100 Sel. 45 rpm)

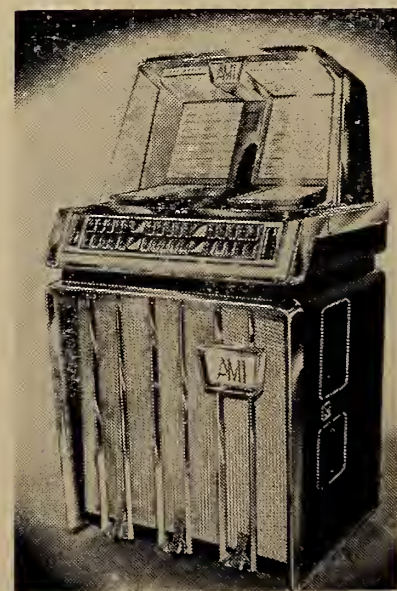

Rowe "J"
(1959 St—Mon. 200 Sel.)
Elec. or Man.
(120 Sel.) (100 Sel.)

**IF YOU... really want to be with it...
PUT IN A ROWE DISCOTHÈQUE—
and dance your way to the bank!**



Rowe exclusive! Stereo-Round,SM the sound of the big band — stereo at its finest. Anywhere — any place in the room, Stereo-Round gives you music with the big sound.

* Stereo Round Sound System
U.S. Patent No. 3,153,120

UP TO 400% EXTRA PROFIT WITH THIS PACKAGE ...

You'll not just double but *quadruple* your profits with this irresistible money-making combination... ROWE and KILLER JOE! Crowds-in-the-know really go-go-go for Rowe and Killer Joe. Put in the ROWE authentic Discothèque, sponsored by Killer Joe,



"Mr. Discothèque" himself... and you'll *pull in* and keep a spending crowd! Remember, your ROWE AMI DIPLOMAT is authentic Stereo-Round with the big-band sound. So for the big-money sound—in your cash register—go-go-go ROWE Discothèque!

**HERE'S
WHAT
ROWE
GIVES
YOU!**

89 EXCITING PROMOTIONAL PIECES ...

Complete merchandising package to establish your Discothèque... Killer Joe 5-foot blow-ups... Striking banners and streamers... plus many interior decorations... Newspaper ads... Radio spots.



ROWE AMI DIPLOMAT...

the musiconsole with the big, live sound of Stereo-RoundSM that makes your place an authentic Discothèque...and makes you authentic dollars.

KILLER JOE PROGRAMMING!

200 selections give you... more program flexibility...more continuous music...more...of what your customer wants.

Rowe[®] AC MANUFACTURING
Troy Hills Road, Whippany, New Jersey

FOR FULL DETAILS, NO OBLIGATION, CALL YOUR ROWE DISTRIBUTOR

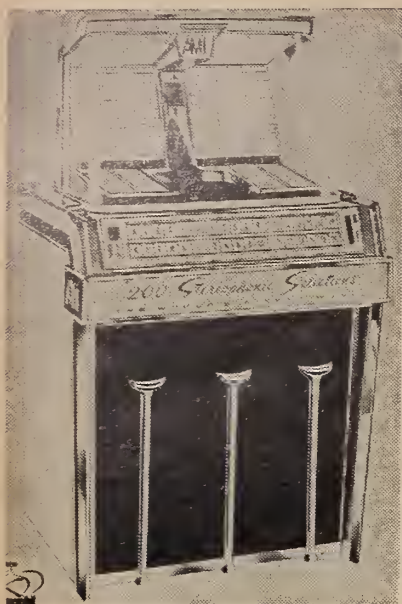

Rowe "K"
(1960 200, 120 or 100 Sel.)

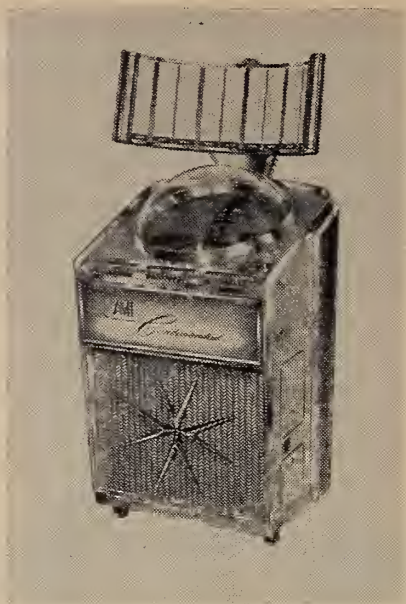

Rowe "Continental 200"
(1960 200—Sel. Lyric 100—Sel.)

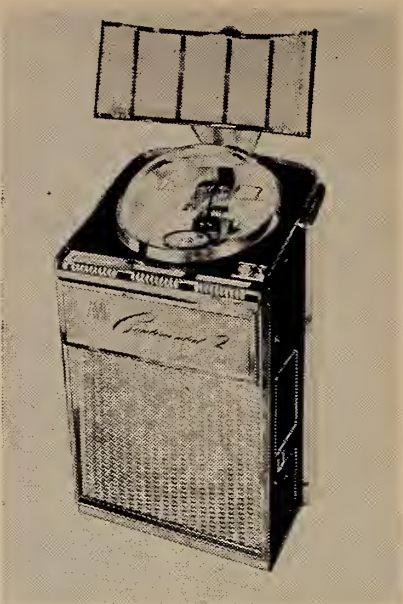

Rowe "Continental 2"
(1961 200 or 100—Sel. 45—33)

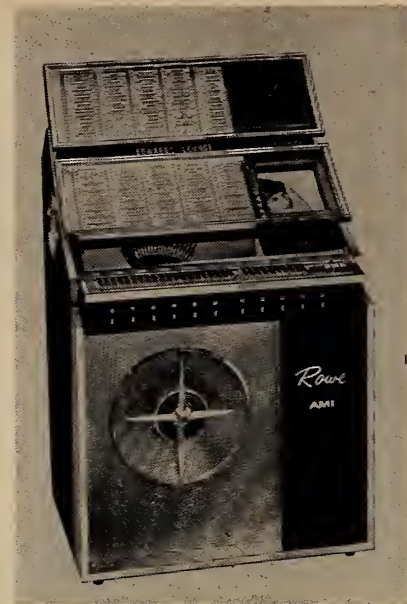

Rowe-AMI
(1962-63 200, 160 or 100—Sel. 45—33)



Rowe "Tropicana"
(1963-64 200, 160 or 100—Sel. 45—33)

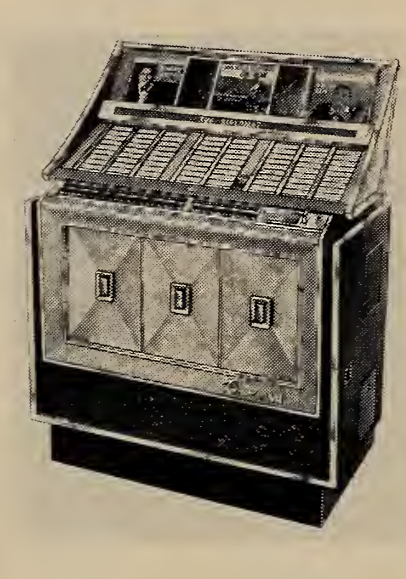

Rowe "Diplomat"
(1965 200, 160 or 100—Sel. 45—33)

**SEEBURG
SALES CORP.**

1500 N. Dayton

Chicago, Ill.

1953 — 1965

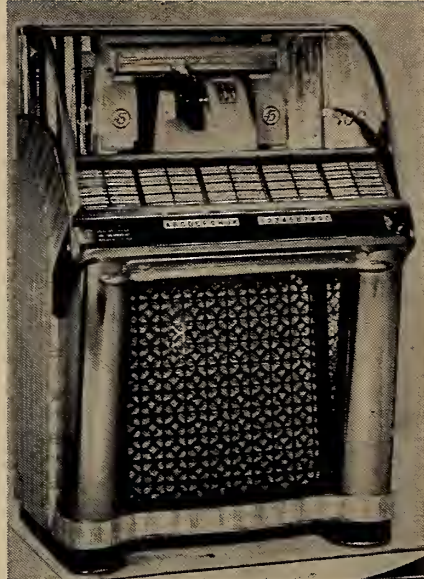

Seeburg HF-100G
(1953 100—Sel. 45 rpm)

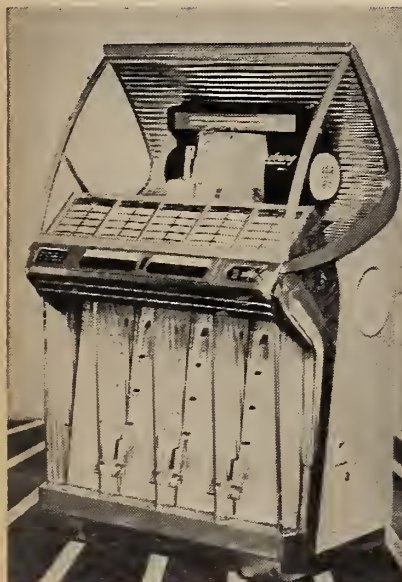

Seeburg HF-100R
(1954 100—Sel. 45 rpm)

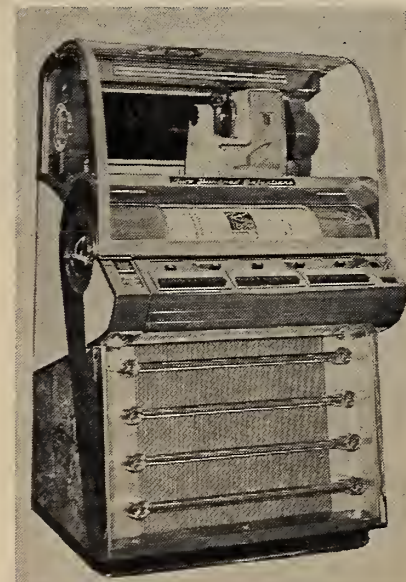

Seeburg V-200
(1955 200—Sel. 45 rpm)

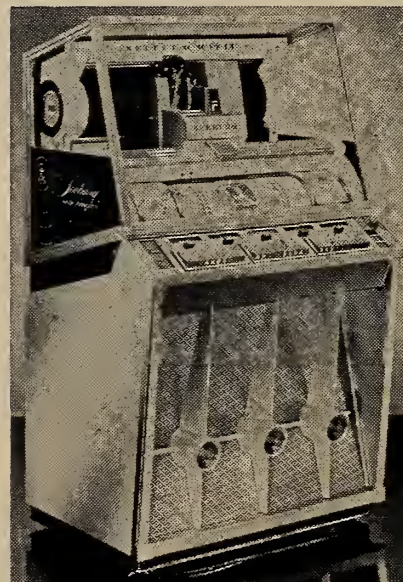

Seeburg KD-200
(1957 200—Sel. 45 rpm)

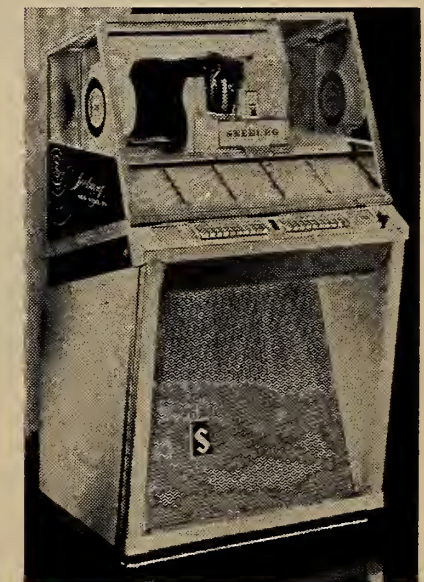

Seeburg L-100
(1957 100—Sel. 45 rpm)



Seeburg "201"
(1958 200—Sel. 45 rpm)

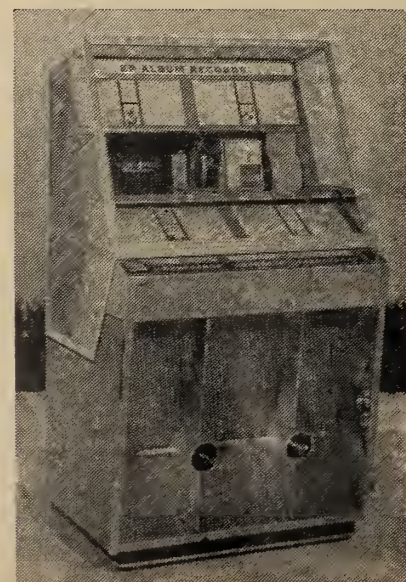

Seeburg "161"
(1958 160—Sel. 45 rpm)



Seeburg "222"
(160—Sel., "220" 100—Sel.)

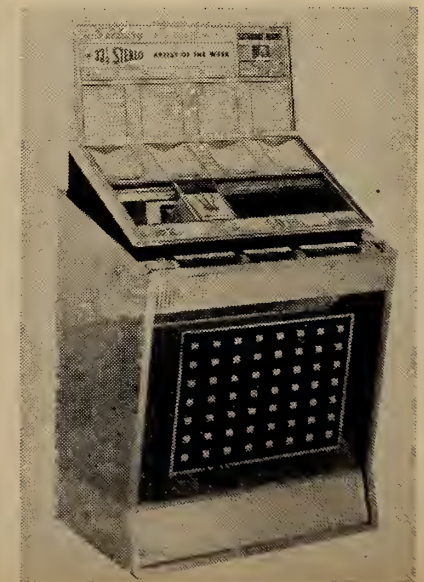

Seeburg "AQ160S"
(1960—160 Sel. 45—33)



* Serving
the
industry
for a
third of a
century

**EXCLUSIVE
DISTRIBUTORS
for the
BEST-SELLING
LABELS**

- ABC PARAMOUNT
- ARGO
- AUDIO SPECTRUM
- CHALLENGE
- CHECKER
- CHESS
- COMMAND
- D C P
- FLEETWOOD
- GOLDEN RECORDS
- GRAND AWARD
- HILLTOP
- IMPERIAL
- IMPULSE
- KAPP
- LIVING LANGUAGE
- LOMA
- MODERN
- MOMUMENT
- MUSIC GUILD
- MUSICOR
- RED BIRD
- REPRISE
- SOMA
- SOUND STAGE 7
- SURE
- TANGERINE
- TUFF
- WARNER BROS.
- WESTMINSTER
- YOUNG PEOPLES RECORDS

★ WE STOCK THE
WORLD'S LARGEST
INVENTORY

THE MOST COMPLETE LINE OF COIN OPERATED EQUIPMENT

HOT DRINKS	HOT DRINKS	PASTRY	CANDY	HOT FOODS	FRESH FOODS	CIGARETTES	COLD DRINKS	
★ ROWE AMI	★ WILLIAMS	★ CHICAGO COIN	★ ROWE AC	★ IRVING KAYE	★ MIDWAY PRODUCTS	★ AUTO PHOTO	★ SOUTHLAND	★ U.S. BILLIARDS

EXCLUSIVE WHOLESALE DISTRIBUTORS

DAVID ROSEN, INC.
amusement vending music machines record dist.

855 NORTH BROAD STREET
PHILADELPHIA, PA., 19123
Phone: (215) CEnter 2-2900

SEND FOR
COMPLETE
COIN
MACHINE
LIST

COIN-OPERATED PHONOGRAPHS

Seeburg —
— Wurlitzer

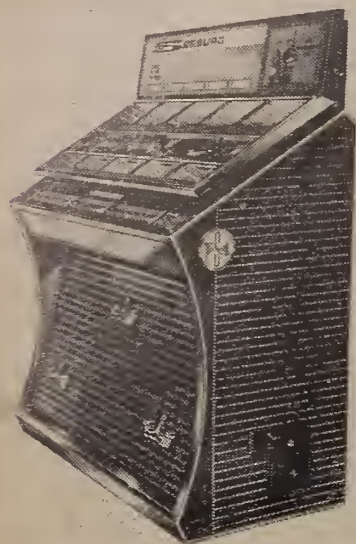

Seeburg "AY160S"
(1961 160—Sel. 45—33)
Model "AY100S" 100—Sel.



Seeburg "DS160"
(1962 160—Sel. 45—33)
Model "DS100" 100—Sel.

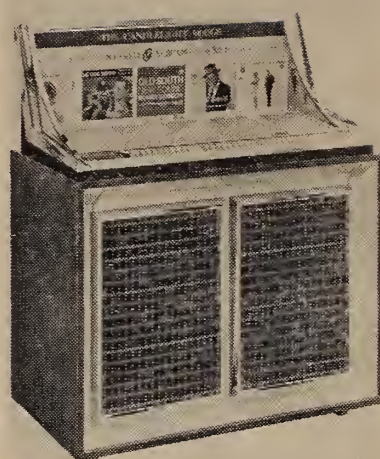

Seeburg LPC-1
(1963-64 160—Sel. 45—33)

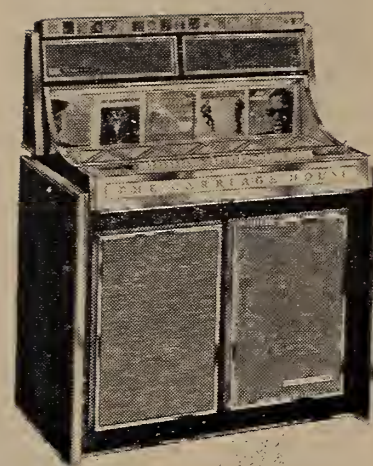

Seeburg LPC 480
45—33 rpm

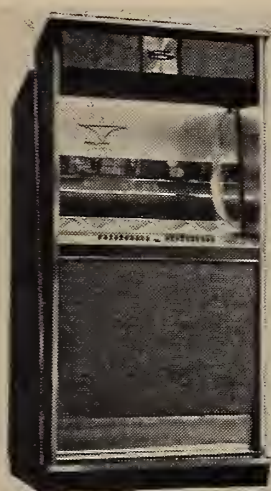

Seeburg "Mustang"
(1965 100—Sel. 45 rpm)

THE WURLITZER CO.
N. TONAWANDA, N.Y.

1953 — 1965



Wurlitzer 1600—1650
(1953 48—Sel. 78 rpm)



Wurlitzer 1700
(1954 104—Sel. 45 rpm)

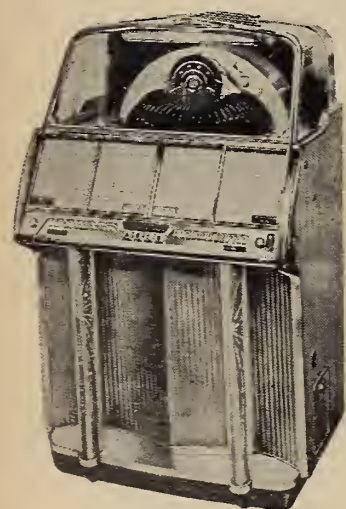

Wurlitzer 1800
(1955 104—Sel. 45 rpm)

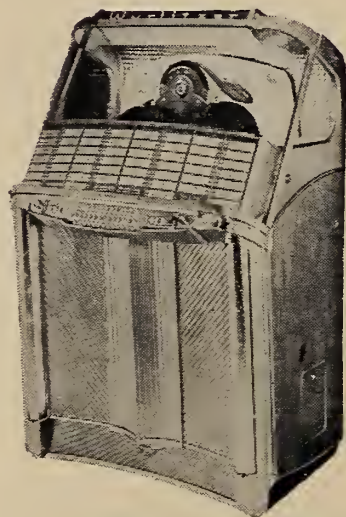

Wurlitzer 1900
(1956 104—Sel. 45 rpm)

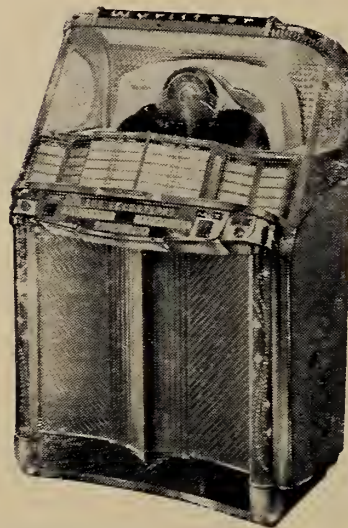

Wurlitzer 2000
(1956 200—Sel. 45 rpm)

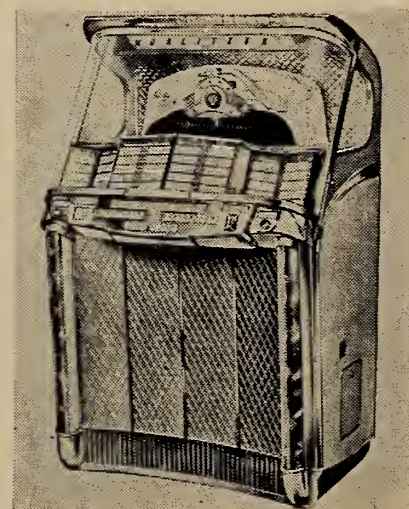

Wurlitzer 2100
(1957 200—Sel. 45 rpm)

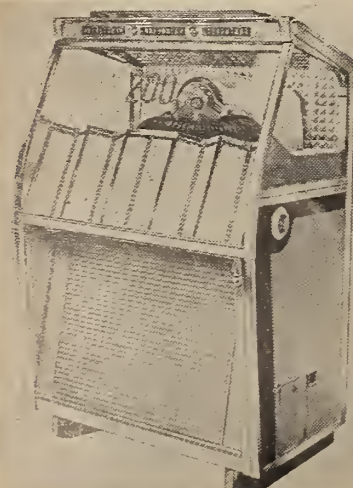

Wurlitzer 2150
(1957 200—Sel. 45 rpm)

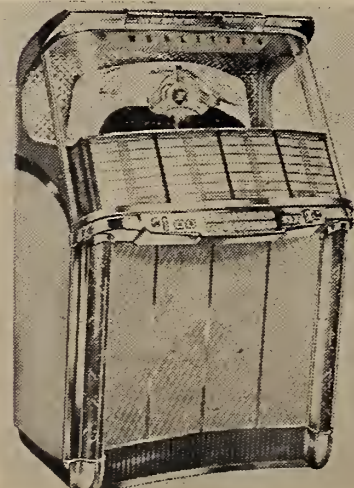

Wurlitzer 2104
(1957 104—Sel. 45 rpm)

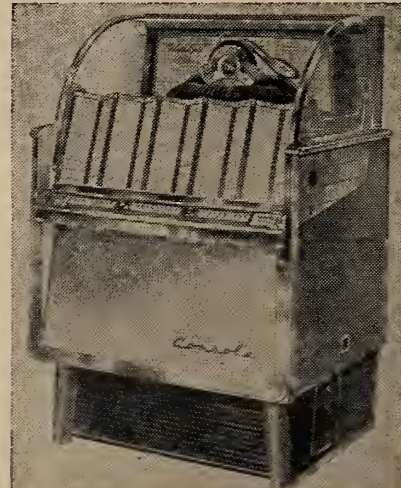

Wurlitzer 2200
(1958 200—Sel. 45 rpm)

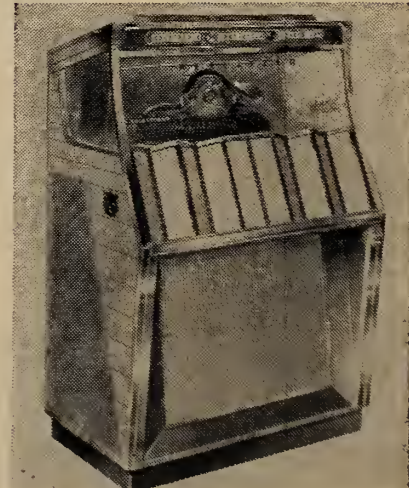

Wurlitzer 2250
(1958 200—Sel. 45 rpm)

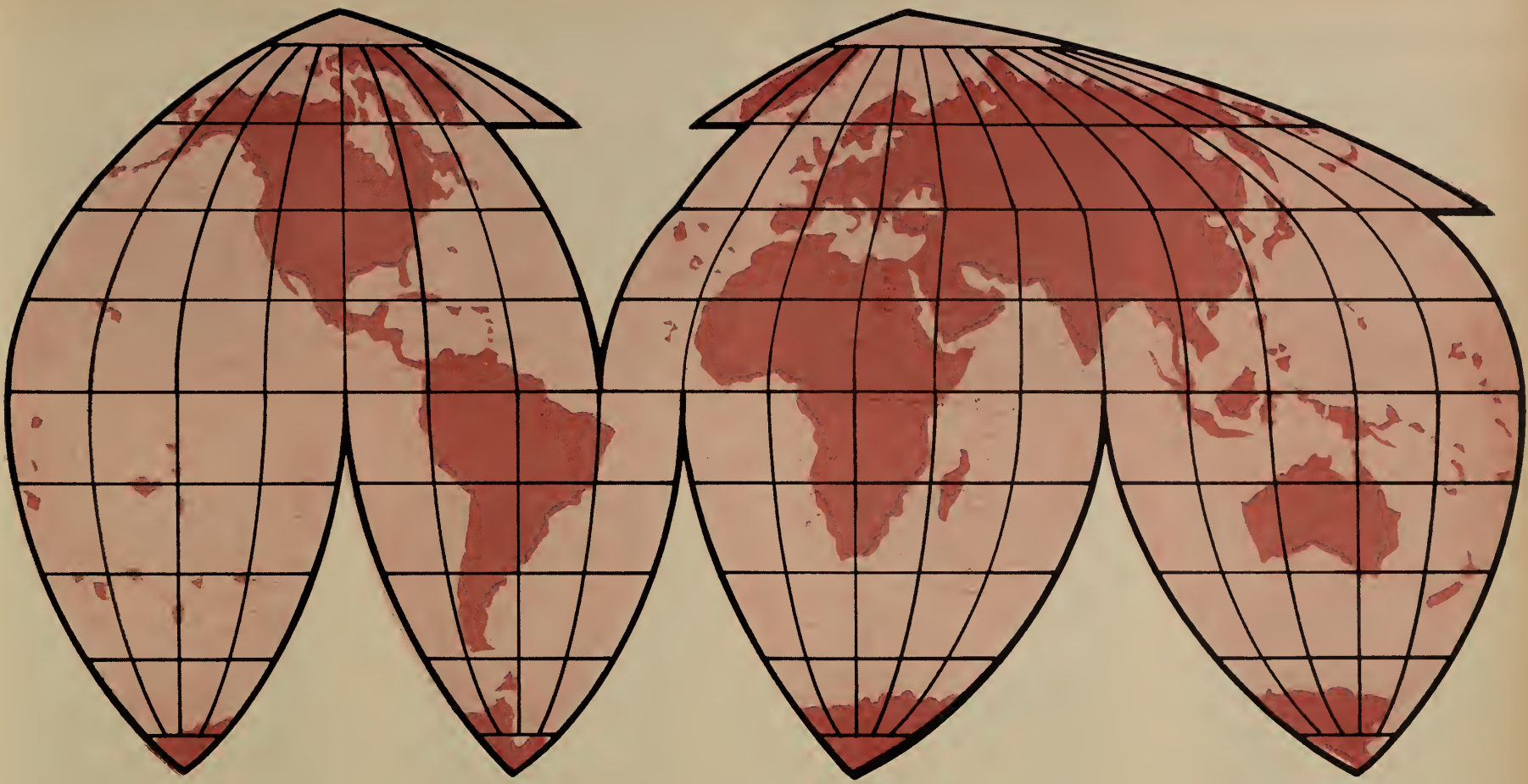

**Phonographs for Tahiti.
Hot tea for Britain.
Discothèque records for Alaska.
Cigarettes for Kuwait.
Background music for Hong Kong.
In music and vending,
Seeburg is the preferred name...
around the world.**

Sales, service, and parts available from these Seeburg Affiliates and Distributors :

Seeben, N. V.
203 Mechelsesteenweg
Antwerpen, Belgium

Seeburg Great Britain Ltd.
430 Edgware Road
London W. 2, England

Seevend Automaten Vertriebs, G.M.B.H.
Fuhlsbuttler Strasse 108 (Drosselhof)
Hamburg 33, Germany

Seerome S. P. A.
Viale Lombardia 72
Milan, Italy

Seerome S. P. A.
Via Gadames 44-46
Rome, Italy

A & D Christoff O. H. G.
Stubenring 16
Vienna 1, Austria

Nordator Oy
Sahaajank. 7
Helsinki 82, Finland

Socodimex S. A.
1, Quai de Grenelle
Paris 15, France

General Espanola de Automaticos S. A.
Calle Valderribas 73
Madrid 7, Spain

Manufacturera de Sinfonolas S. A.
Avenida Jardin 330
Mexico 15, D. F., Mexico

Philippine Amusement Enterprises
P. O. Box 2952
Manila, Philippines

Musikvertrieb A. G.
Badenerstrasse 555
Zurich, Switzerland

Distribuidoras Unidas C. A.
Avenida Mexico No. 229
Caracas, Venezuela

Taito Trading Co., Ltd.
Central P. O. Box 1164
Tokyo, Japan

Pan Nordic Automation
P. O. Box 18
Saro, Sweden

Mr. Peter Thomas
Avenida Universitaria
San Salvador, El Salvador

Seeburg Automatic Products Pty., Ltd.
400 Kent Street
Sydney, Australia

Seeburg (Aust.) Pty., Ltd.
136 Nelson Street
Annandale, Sydney, Australia

Stockdales Industrial Venders Limited
Heacham, King's Lynn
Norfolk, England

Codiscos-Compania Colombiana
De Discos S. A.
Apartado Aereo No. 14-28
Medellin, Colombia

The Seeburg Sales Corporation, 1500 N. Dayton St., Chicago, Illinois 60622. Cable address: SEEBUR CHICAGO

Coin-operated Phonographs

**Wurlitzer—
Scopitone**



Wurlitzer 2300
(1959 200—Sel. St—Mon)
2304—104—Sel., 2310—100—Sel.

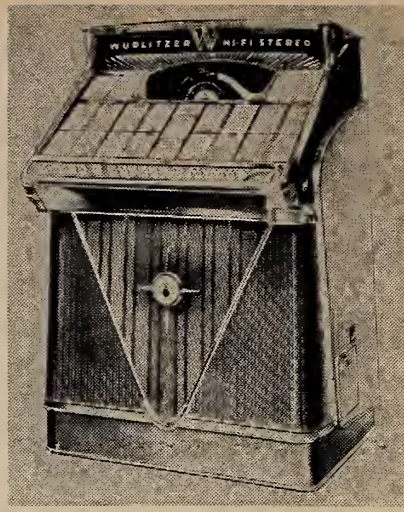

Wurlitzer 2400
(1960 200—Selections)
2404—104—Sel., 2410—100—Sel.



Wurlitzer 2500S
(1961 200—Sel. 45-33 Avail)
2504—104—Sel., 2510—100—Sel.



Wurlitzer 2600
(1962 200—Sel. 45-33)
Model 2610 100—Sel.



Wurlitzer 2700
(1963 200—Sel. 45-33)
Model 2710 100—Sel.

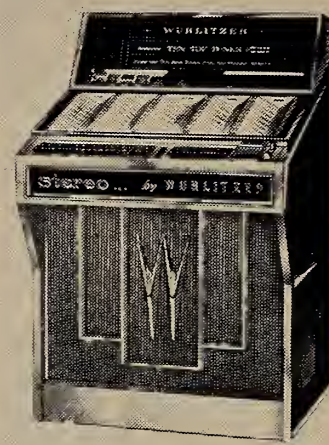

Wurlitzer 2800
(1964 200—Sel. 45-33)
Model 2810 100—Sel.



Wurlitzer 2900
(1965 200—Sel. 45-33)
Model 2910 100—Sel.

**United
Mfg. Co.**
1957 — 1961



United UPA-100
(1957 100—Sel. 45 rpm)

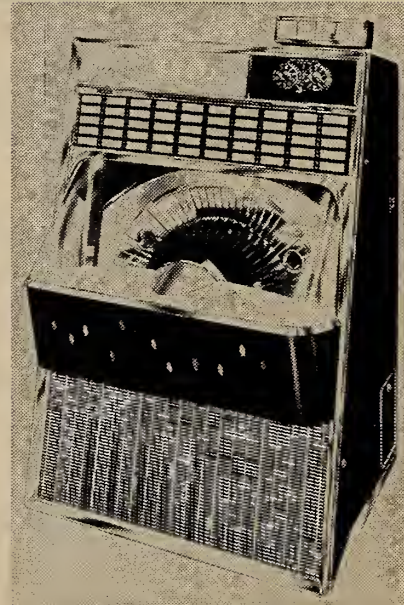

United UPC-100
(1960 100—Sel.)



United UPD-100
(1961, 62, 63—100 Sel.)

COIN-OPERATED AUDIO-VISUAL MACHINES



United UPB-100
(1959 100—Sel. St—Mon)



COLORAMA
Intersphere Development Corp.
Burns Rd., Hicksville, N. Y. 8 mm
film projector 40-selections. Pro-
duction scheduled for Jan. 1966

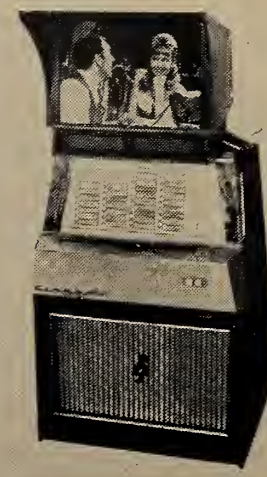

FILMOTHEQUE-DISCOTHEQUE
David Rosen Inc. (Licensee) 16
mm film projector 20-sel. 855 No.
Broad St., Phila., Pa. Manufact-
ured in USA



SCOPITONE
Tel-A-Sign Corp. 3401 West 47 St.,
Chicago, Ill. 16 mm film 36-sel.
Manufactured in USA

Deluxe Eldorado "66"

OPERATOR'S DREAM COME TRUE



Cushion moldings are held to top frame by machine screws. No more stripped wood or broken screws. (Spin tight provided with each table). Aluminum molding between cabinet and top frame hides all screws.

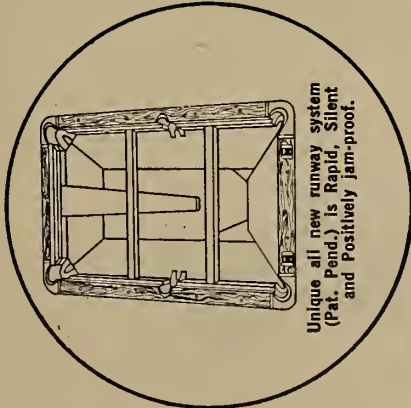

Unique all new runway system (Pat. Pend.) is Rapid, Silent and Positively Jam-proof.

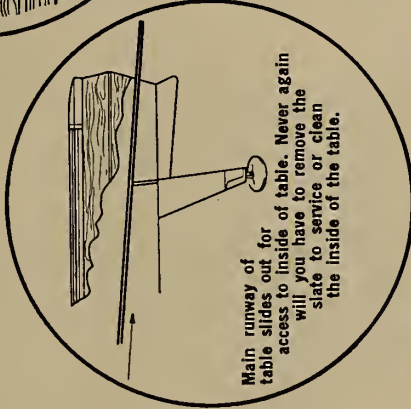

Main runway of table slides out for access to inside of table. Never again will you have to remove the slate to service or clean the inside of the table.

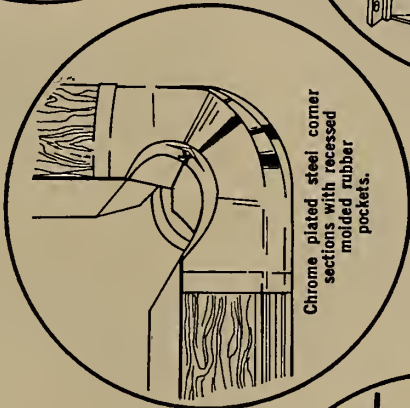

Chrome plated steel corner sections with recessed molded rubber pockets.

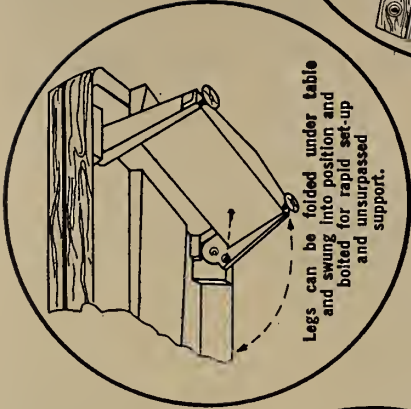

Legs can be folded under table and swung into position and bolted for rapid set-up and unsurpassed support.

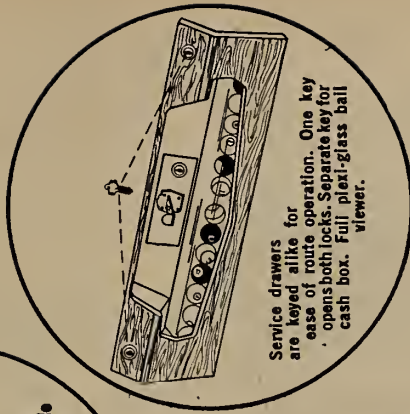

Service drawers are keyed alike for ease of route operation. One key opens both locks. Separate key for cash box. Full plexi-glass ball viewer.

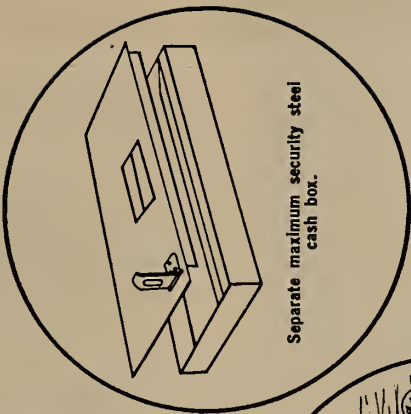

Separate maximum security steel cash box.

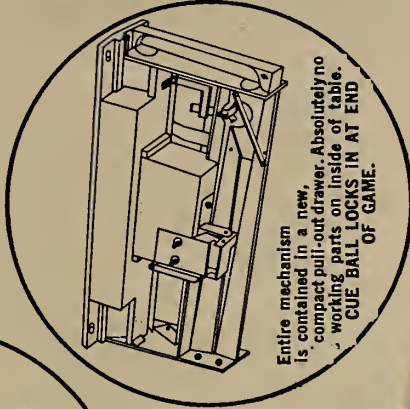

Entire mechanism is contained in a new compact pull-out drawer. Absolutely no working parts on inside of table. CUE BALL LOCKS IN AT END OF GAME.

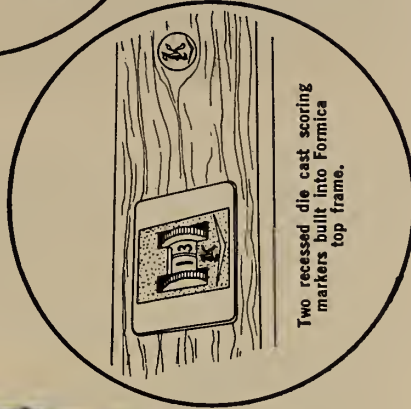

Two recessed die cast scoring markers built into Formica top frame.

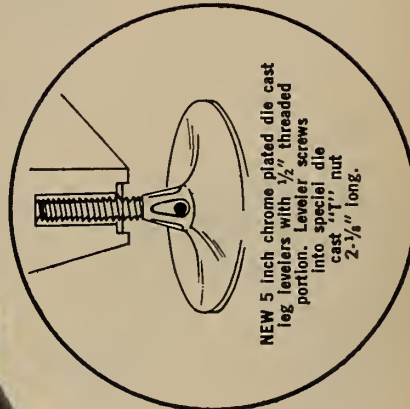

NEW 5 inch chrome plated die cast leg levelers with 1/2" threaded portion. Leveler screws into special die cast "T" nut 2-3/8" long.

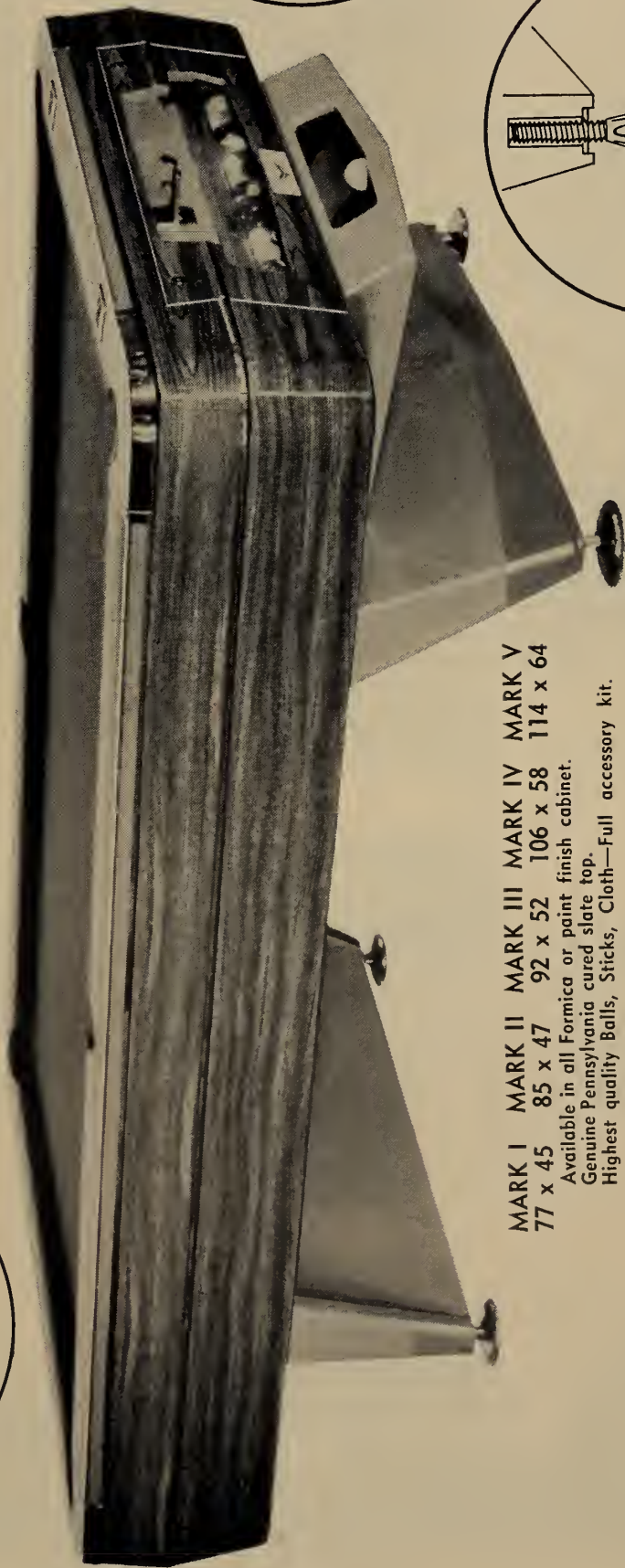

MARK I 77 x 45 MARK II 85 x 47 MARK III 92 x 52 MARK IV 106 x 58 MARK V 114 x 64

Available in all Formica or paint finish cabinet. Genuine Pennsylvania cured slate top. Highest quality Balls, Sticks, Cloth—Full accessory kit.

Irving K. Kaye Co. Inc.

363 Prospect Place Brooklyn 38, N. Y. Sterling 3-1200

AMUSEMENT MACHINES

Produced July '64—June '65 U.S. Factories

Pool Tables

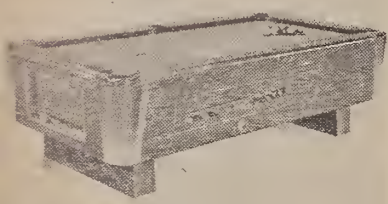

AMERICAN
Classic 6', 7' and 8' Models
also Electra Model
(with battery operated
drop coin mechanism)
6', 7' and 8' Models

Pool Tables



FISCHER
Empire VII and Empire VIII
Model VII is 31½ by 57 by 101"
Model VIII is 31½ by 52 by 92"

Pool Tables



IRVING KAYE
Deluxe Klub Pool
JUMBO: 75"x43"

Pool Tables

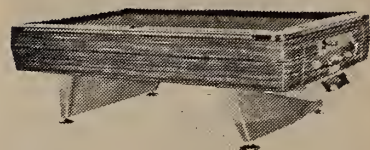

IRVING KAYE
Deluxe Eldorado
Mark II 85 by 47 inches



AMERICAN
Electra 6', 7' and 8' Models

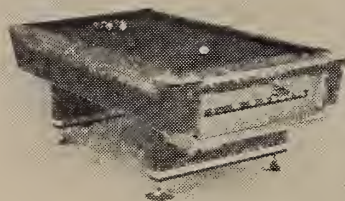

FISCHER
Regent Model 77
31½ by 45 by 77"
(Model 91 is 31½
by 52 by 92")



IRVING KAYE
Deluxe Satellite
77"x45"



IRVING KAYE
Deluxe Eldorado
Mark III 92 by 52 inches

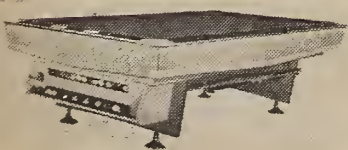

ALL-TECH
Regulation Model
4½ feet by 9 feet



FISCHER
Fiesta 58
31½ by 42 by 58"



IRVING KAYE
Ring-O-Model
Elliptical playfield

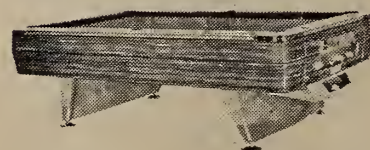

IRVING KAYE
Deluxe Eldorado
Mark IV 105 by 57 inches

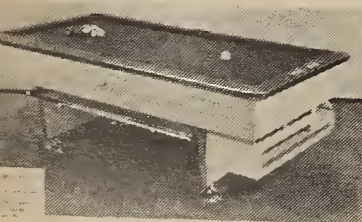

ALL-TECH
Gold Crest Model
4 feet by 8 feet



GREAT LAKES
Elliptipool Model
Elliptical playfield



IRVING KAYE
Ambassador Model
(Available in 7 7½,
8 and 9 foot sizes)



IRVING KAYE
Deluxe Eldorado
Mark V 114 by 64 inches

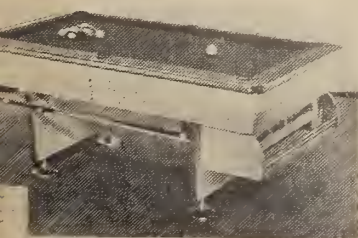

ALL-TECH
Gold Crest Model
46 inches by 78 inches



IRVING KAYE
Deluxe Klub Pool
Regular 56"x40"



IRVING KAYE
Deluxe Eldorado "66"
Mark I 77 by 45 inches



NATIONAL
Coronet Line
Models available in 5 sizes

Now THE NUMBER **1** NAME IN...

POOL TABLES



PRO 1
78"x46"



PRO 2
88"x51"



PRO 3
93"x53"



PRO 4
103"x58"



PRO 5
114"x64"



An exciting new concept that speeds installation that is perfect in all respects—even by unskilled labor!

PROFESSIONAL BILLIARD LOUNGE
108" x 42"

FEATURES...

1. 15th Ball Cue Ball Lock
2. Double Bulkhead Cabinet
3. Genuine Slate - Only
4. Post Formed Mica rails
5. Access to runways - without Removing Slate
6. Polyethelene Lined Runways
7. Adjustable Bolt & T-Nut Cushion Moulding Attachment. (Pat. Pend)
8. "H" Frame Leg Construction (Backbone - No Slate Sag)
9. Split Ball return (Club Pool)
10. Locked Meters
11. Complete Mica Cabinet & Legs (standard)

for information call 516-798-2626

U S BILLIARDS, Inc.

Amityville, New York

or your local U.S. Billiards, Distributor

AMUSEMENT MACHINES

Produced July '64—June '65 U.S. Factories

Pool Tables



VALLEY
 MODELS 1785, 1885 and 1935
 Measuring 78 by 45 by 31,
 88 by 50 by 31 and
 93 by 53 by 31 inches



VALLEY
 MODELS 785A, 875A and 935A
 (Same measurements as above)

Pool Tables

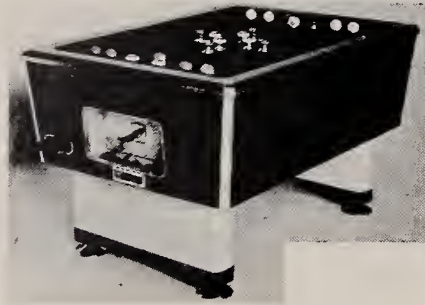

U.S. BILLIARDS
 Club Pool Model
 55½ by 39½ inches



U.S. BILLIARDS
 Regulation Table
 Measuring 9 by 4½ feet

Shuffleboard

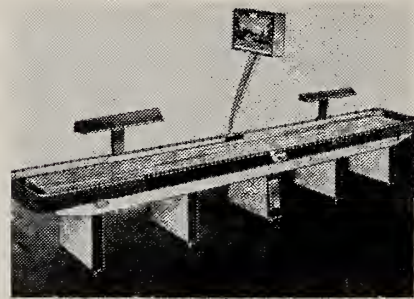

American IMPERIAL

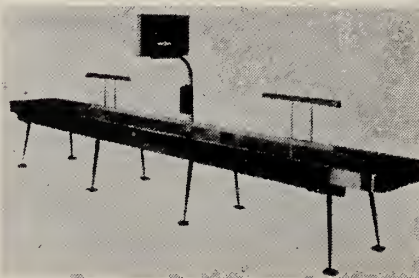

NATIONAL
 Professional Model

Novelty Games



Midway RIFLE CHAMP

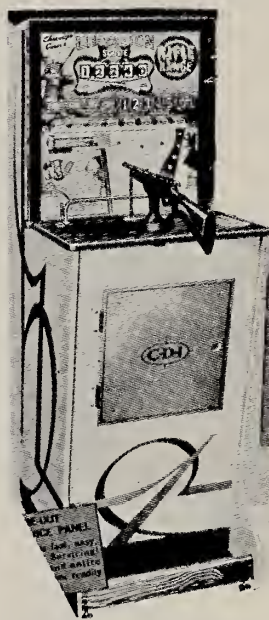

CHICAGO COIN
 Champion Rifle Game

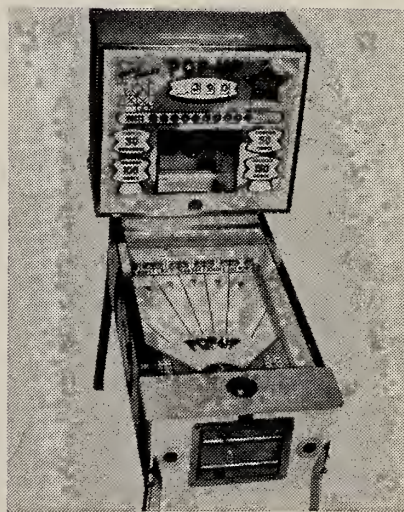

CHICAGO COIN POP UP

Baseball Games



ChiCoin BIG LEAGUE 4P



Midway PLAY BALL

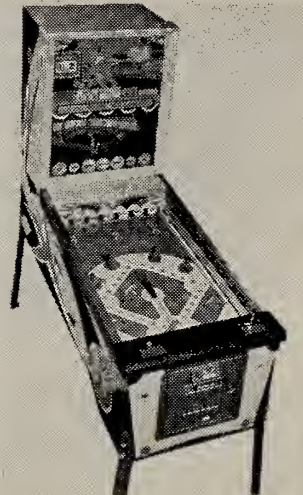

Williams Double Play



MARVEL
 Shuffleboard Scoreboard



VALLEY
 Bumper Pool Model 565

U.S. BILLIARDS
 PRO Line for 1965
 Models 1, 2, 3, 4 and 5



U.S. BILLIARDS
 PRO Models (Original line)
 Pro 1, 2, 3 and 4



MARVEL
 Coin Unit

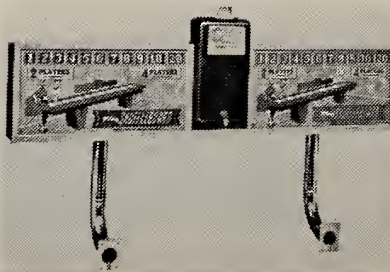

MARVEL
 Sidemount Scoreboard

Valley[®]

the "Cadillac" of Quality and Craftsmanship



CHECK THESE NEWEST FEATURES!

- * Complete new operating mechanism
- * Revamped internal structure - faster ball return
- * Bolted rails (for more solid holding and faster ball action)
- * Easily removable ball viewer door - heavy drawer eliminated
- * New color combinations of Walnut and White Formica covers entire table, including legs.
- * Locked in cue ball
- * Feather touch coin operating mechanism
- * Recessed Coin Chute - separate from cash box
- * Redesigned separate locked cash box - inaccessible except thru its door

Model #1785 Size 78 x 45 x 31
Model #1875 Size 87 x 50 x 31
Model #1935 Size 93 x 53 x 31

THE FINEST POOL TABLE VALLEY EVER BUILT

Valley[®] manufacturing & sales company

333 MORTON STREET • BAY CITY, MICHIGAN • TWINBROOK 5-8587

Film Machines



URBAN
Model AP-10

Photo Machines



AUTO-PHOTO STUDIO

Model 12
Produces 3 Prints 2"x2½" ea.

Model 14
Produces 4 Prints 1½"x2" ea.

Slot Car Units

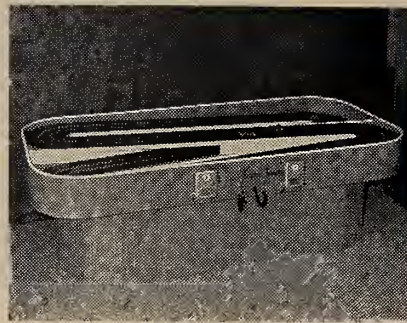

INTERNATIONAL
Flying Eight

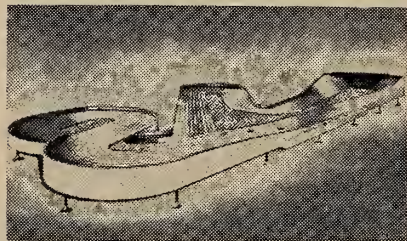

ALL-TECH
Big Ben (Non-Coin)

Kiddie Rides



Hawkins
TWIN QUARTERHORSE

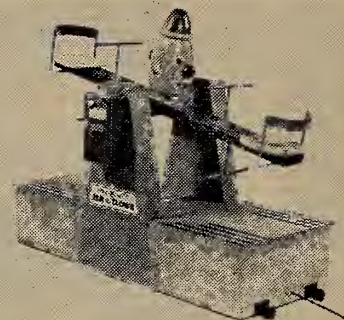

Hawkins SAM THE CLOWN
(Hawkins rides not shown)

RODEO PONY, DONNIE DUCK,
LEO THE LYON, DERBY PONY
JR., MUSTANG and BEN HUR
CHARIOT



URBAN
Model KKT

Seal-In Plastic Units

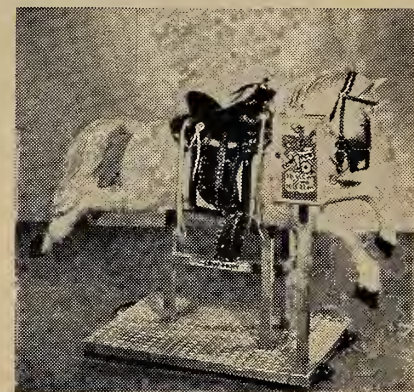

Exhibit KLEER SEAL VENDER
Vends 2⅞"x4¼" Material

Golf Game



WMS. Hollywood Driving Range



ALL-TECH
Cow Pony

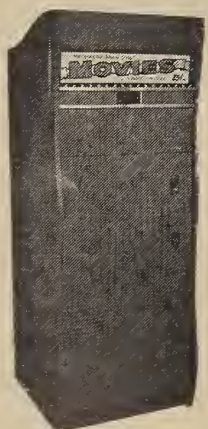

URBAN
Model AD Panoram

Metal Typer

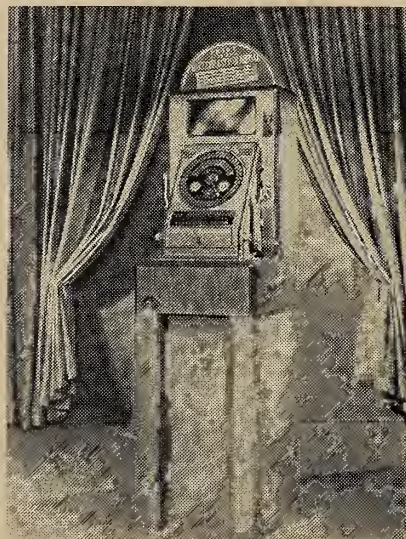

STANDARD HARVARD

Ski Machine



DuKane SKI 'N SKORE

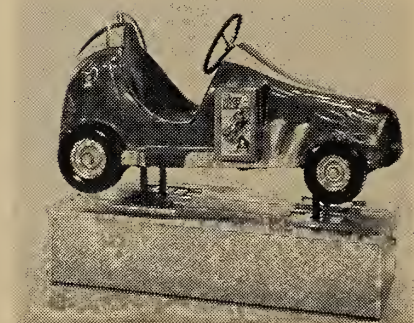

ALL-TECH
Midget Racer

(All-Tech models not shown)

KIDDIE HI-WAY PATROL, SANTA
FE EXPRESS, The STAGE COACH,
CHUCK WAGON, FIRE ENGINE,
INDIAN SCOUT, HELICOPTER and
SATELLITE EXPLORER

Kiddie Rides



MODERN PRODUCTS
Army Tank



MODERN PRODUCTS
The Satellite

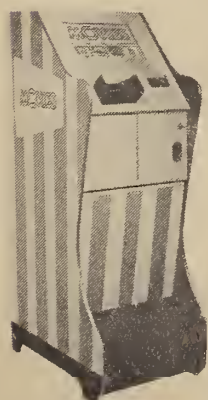

URBAN
Model AP-10 Console

set your sights higher
and you'll choose



210 Paterson Plank Road, Union City, N.J.
(201) UNion 5-6633

1423 S. Western Avenue, Los Angeles, Calif.
(213) REpublic 3-3724



The **CLASSIC**, with cheat-proof "Feather Touch" coin mechanism, and The **ELECTRA**, with battery operated drop coin mechanism, are both available in three popular sizes and all new models of both tables have a conversion feature which enables the operator to change The **ELECTRA** to The **CLASSIC** or The **CLASSIC** to The **ELECTRA** by simply changing the cash box door.

- One piece customized cabinet made with genuine Formica
- Sturdier legs made with genuine Formica Famed American leg adjusters
- Genuine Formica top rails
- Steel corners
- Specially designed professional cushions
- Finest cured slate top
- Silent, steel wire runways
- Exclusive cue ball lock
- Deluxe accessories.



The IMPERIAL, World Famous Shuffleboard

- Outstanding construction throughout
- Cantilevered scoreboard
- Built in scoreboard light
- Beautiful end lamps for illumination
- Horse Collar play control
- Tamper proof pin gate control — even when electricity is off—or exclusive Magno Play Control available.

WRITE FOR FREE COLOR BROCHURE OR SEE THEM AT YOUR DISTRIBUTOR

Pingames



Bally BAND WAGON 4P

Pingames



Bally BUS STOP 2P

Pingames



Bally SHEBA 2P

Pingames



Gottlieb BOWLING QUEEN 1P



Bally BIG DAY 4P



Bally GRAND TOUR 1P

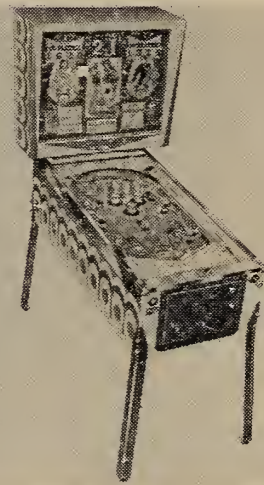

Bally 2 IN 1 2P

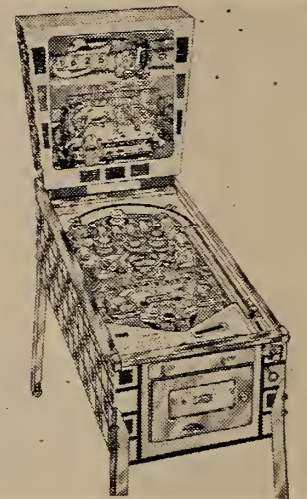

Gottlieb BUCKAROO 1P



Bally BORDER BEAUTY
(in-line)



Bally HARVEST 1P



ChiCoin MUSTANG 2P



Gottlieb HAPPY CLOWN 4P



Bally BULLFIGHT 1P



Bally MAGIC CIRCLE 1P



ChiCoin ROYAL FLASH 2P



Gottlieb HI DOLLY 2P

U. S. TRADE ASSOCIATIONS

NATIONAL

Music Operators of America
228 North LaSalle St.
Chicago, Illinois
Pres. Clint Pience

National Automatic Merchandising Association
7 South Dearborn Street
Chicago, Illinois
Pres. J. Richard Howard

National Coin Machine Distributors Association
30 North LaSalle Street
Chicago, Illinois
Exec. Div. Bob Sliter

National Vendors Association
134 No. LaSalle
Chicago, Illinois
Pres. Ted Raynor

National Vending Machine Dist. Assn.
4711 E. 27 St.
Kansas City, Mo. 64127
B. K. Bitterman, Secretary-Treasurer

LOCAL

Alabama Amusement Assn.
224 Dexter
Montgomery, Ala.
Isaac Cohen

Arkansas Music Operators Assn.
609 Rector Bldg.
Little Rock, Ark.
Charles Stewart

Arizona Music Guild
P.O. Box 14011
Phoenix, Arizona
Exec. Sec. John Hourihan

Bridgeport Coin Machine Operators Assn.
520 Success Ave.
Bridgeport 10, Conn.
James V. Fitzpatrick

California Music Merchants Assoc.
128 E. 14th St.
Oakland 6, Calif.
Pres. George Miller

Music Operators of Connecticut
242 Trumbull St.
Hartford, Conn.
Pres. Jerry Lambert

A.M.O.A. of Florida
8163 N.E. 2nd Ave.
Miami, Fla.
Pres. James I. Mullins

No. Fla. Amusement & Music Assoc.
695 W. Monroe St.
Jacksonville, Fla.

Record Music Service Assoc.
Room 1605
188 Randolph St.
Chicago, Ill.
Pres. Earl Kios

Illinois C. M. Operators Assoc.
157 N. Fernsworth
Aurora, Illinois
Pres. Bill Poss

Music Guild of Southern Illinois
414 Langdon Ave.
Alton, Ill.
Harry Schaffner

Illinois Amusement Assn.
208 N. Madison St.
Rockford, Ill.
Lou Casola

Music Operators of No. Illinois
8020 Lincoln Ave.
Skokie, Ill.
Pres. Robert Lindelof

Houston C. M. Ops. Assoc.
Rm. 609
401 Louisiana
Houston, Texas
Pres. Jack Staz.

Music Operators Society of St. Jos. Valley
130 N. Ironwood Dr.
Mishawaka, Ind.
Pres. Frank R. Fabiano

Iowa Music Operators Assn.
1337 2nd Ave.
Des Moines, Iowa
Pres. Jack Jeffreys

Kansas Music Merchants
Salina, Kans.
Pres. Richard McClanathon

Half game, half circus!

100% EARNING ENERGY!



Light Targets on right or left side of Playfield by skill-shot across one of the four Side-Selector Top Rollovers, then shoot to build up maximum scores on selected side before hitting Change-Targets Bumper which lights Targets on opposite side. Back-and-forth action between twin sides of playfield is as wildly exciting, suspense-packed and loaded with surprises as a three ring circus, keeps players coming back for long sessions of repeat play.

27 ways to build high scores plus free balls

Bally 50/50, from Top Rollovers to Out-Hole, is designed to insure extra potent play-appeal, extra rich earning-power. Get your share. Get Bally 50/50 now.



ONE OR **2** CAN PLAY

See your distributor or write **BALLY MANUFACTURING COMPANY • 2640 BELMONT AVENUE, CHICAGO 18, ILLINOIS, 60618, U. S. A.**

Phonographic Equipt. First Year Report

LONDON—As Phonographic Equipment (Distributors) Ltd. nears the end of its first year as a public company the directors report very satisfactory results in all spheres.

The coin machine business is expanding rapidly and Phonographic claims more than their fair share of the business.

The company enjoys extremely good distributor-operator relations maintained by their own sales force which continually travels up & down the country.

Phonographic Equipment have done a good job for all their manufacturers during the past twelve months including William and United, Bally, Seega and Jupiter etc.

MUSIC BOXES
We can supply your needs for all models of WURLITZER—SEEBURG—A.M.I.—ROCK-OLA
Write for Special Prices

AMUSEMENT GAMES			
Arizona Gun	\$295	Kay Hockey	\$125
Auto Photo #9	695	MacLevy Ft. Vibrator	135
Bally Fun Fone	95	Merc. Floor Grip	85
Cap. Midget Movies	110	Metal Typer, Standard	225
C.C. Drop Ball	125	All Teeh	
C.C. Pro-Basketball	250	Chuck Wagon	395
C.C. Goalee	110	Bally Toonerville	
Ex. Hi-Ball	75	Trolley	300
Evans Hole-in-One	95	Bert Lane	
Geneo 2 Pl.		Merry Go Round	295
Basketball	135	Bert Lane Miss America	
Ingo Floor Grip	50	Boat	295
All Teeh		Fire Engine	\$395
Un. Slugger	\$110	Midway Red Ball	125
Wms. Sidewalk Engineer	110	Midway Skee Fun	125
Wms. Peppy	175	Muto Lord's Prayer	150
Wms. Ten Pins	125	Muto Plastic Vendor	95
Wms. Crane	125	Muto Cross Country	195
Waiting Scale	110	Panorams, Capitol	275
Cap. Donald Duck	250	Urban Color Kiddie	
Ex. Red Nose Reindeer	245	Movies	325
Kings Choo-Choo Train	250	Shoe Shiner	150
Sandy Horse	325	Southland Speedway	
Scientific Boat	295	2 Pl.	295

Write for our latest price bulletin for complete quotations on FLIPPER GAMES, ARCADE EQUIPMENT, POOL TABLES, VENDING MACHINES, SHUFFLE ALLEYS AND BOWLERS.

CLEVELAND COIN International

2029 PROSPECT AVE., CLEVELAND 15, OHIO
All Phones Tower 16715

Pingames

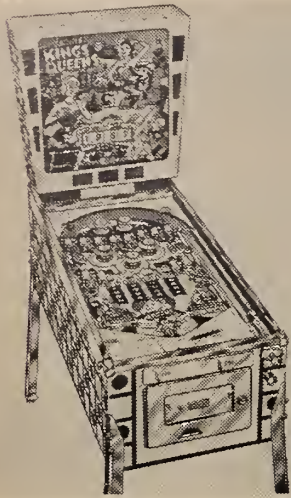

Gottlieb *KINGS & QUEENS 1P*

Pingames



Gottlieb *SKY-LINE 1P*

Pingames



Williams *HEAT WAVE 1P*

Pingames



Williams *WHOOPEE 4P*



Gottlieb *MAJORETTES 1P*

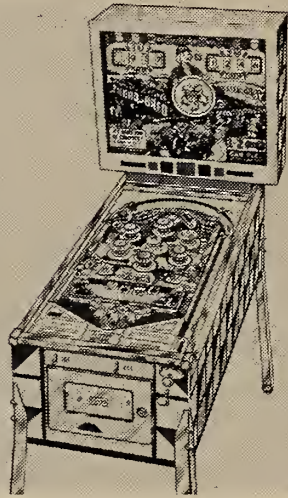

Gottlieb *THORO-BRED 2P*



Williams *MOULIN ROUGE 1P*



Williams *ZIG-ZAG 1P*



Gottlieb *NORTH STAR 1P*



Midway *RODEO 2P*



Williams *PRETTY BABY 2P*

PROTCISION

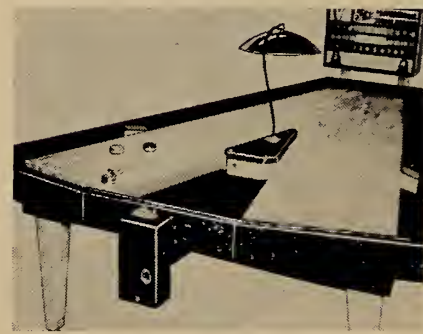

ASTROLITE

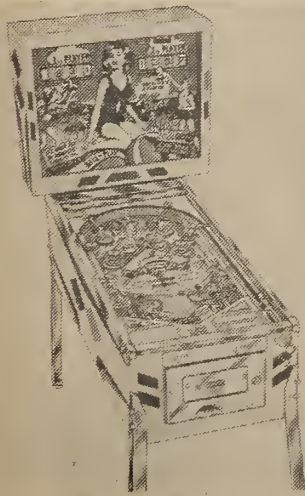

Gottlieb *SEA-SHORE 2P*



Williams *ALPINE CLUB 1P*



Williams *RIVER BOAT 1P*



MARVEL SLUGGER

Shuffle Alleys

Shuffle Alleys

Bowlers

Bowlers

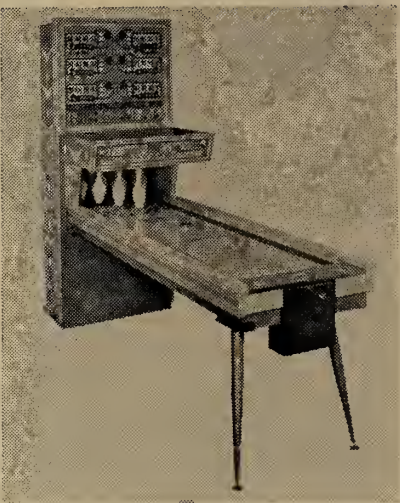

ChiCoin DeVILLE

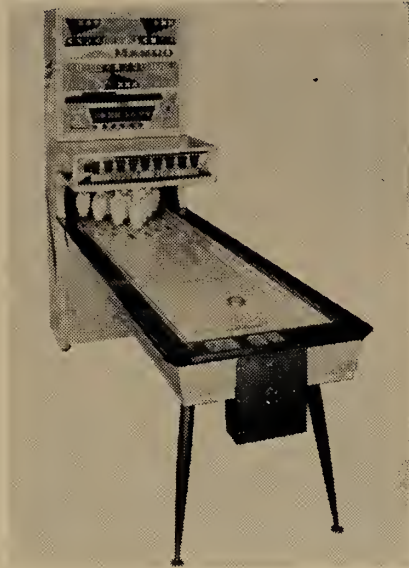

United MAMBO

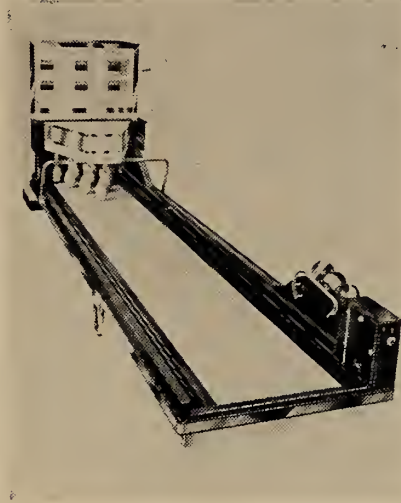

1965 BALLY BOWLER

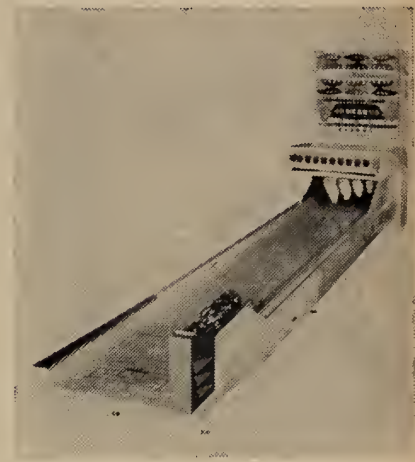

United MATADOR



ChiCoin TOP BRASS

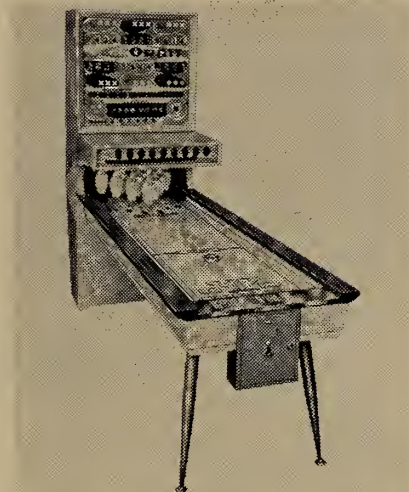

United ORBIT

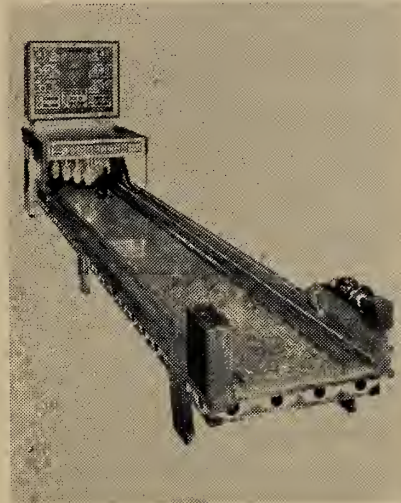

ChiCoin MAJESTIC

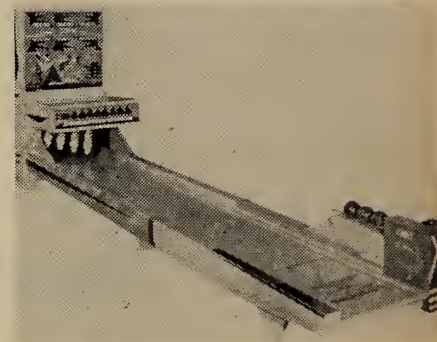

United OASIS

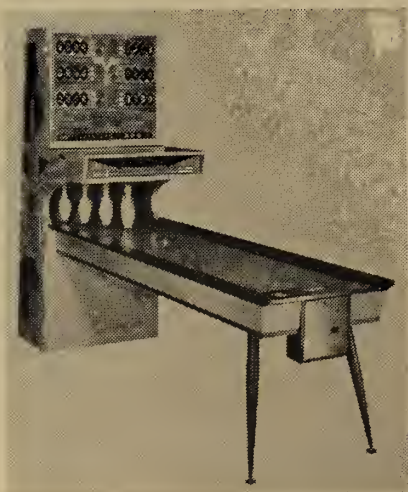

ChiCoin TRIUMPH

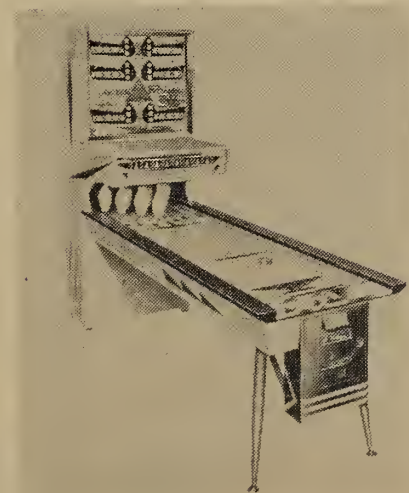

United PYRAMID

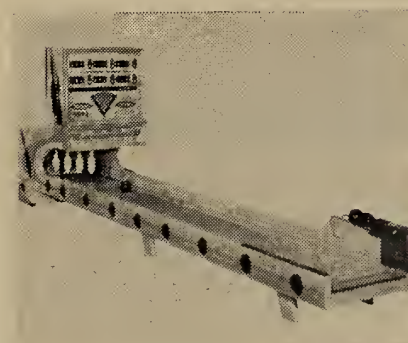

ChiCoin SUPER-SONIC

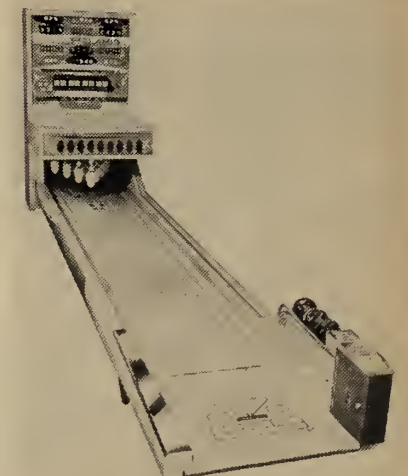

United POLARIS

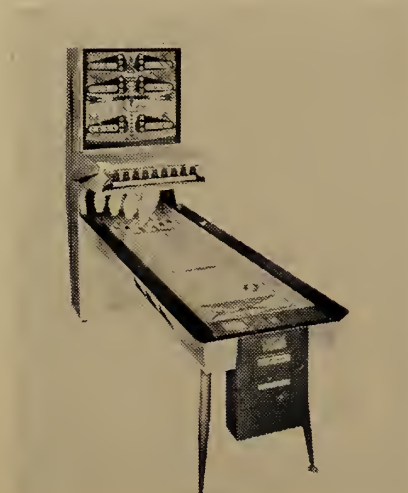

United CHEETAH

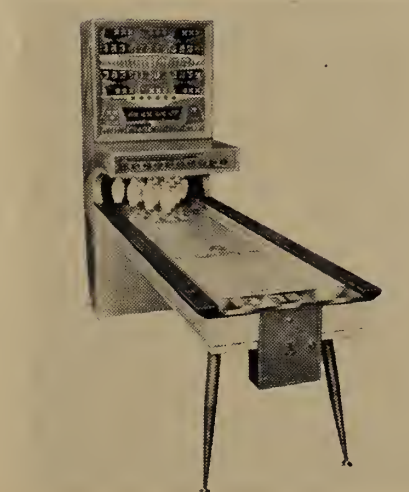

United TIGER

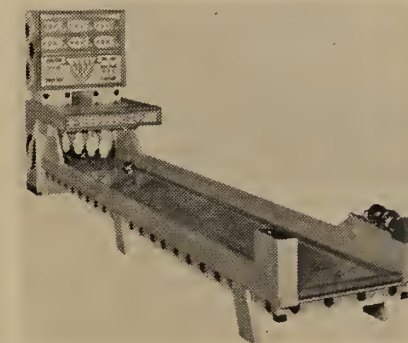

ChiCoin TOURNAMENT

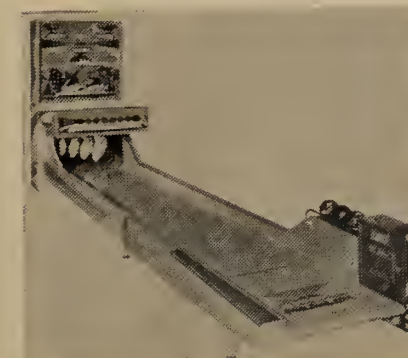

United GALLEON



Bally ALL THE WAY

CONGRATULATIONS

to
CASH BOX

on its
23rd Anniversary

Thanks for all your achievements
in behalf of the Coin-Machine Operators

Amalgamated Machine Operators Ass'n.

8163 N.E. 2nd Ave. • Miami, Fla.
James I. Mullins, Pres.

BEST WISHES

To

CASH BOX

ON YOUR 23rd ANNIVERSARY

HASTINGS DISTRIBUTING COMPANY, INC.

(Since 1932)

6100 W. BLUEMOUND ROAD, MILWAUKEE 13, WISCONSIN

SINCEREST BEST WISHES TO

CASH BOX

on its 23rd Anniversary

ILLINOIS COIN MACHINE OPERATORS ASSN.

157 NO. FARNSWORTH, AURORA, ILLINOIS
898-4122

A-1 RECORD SALES

EXCLUSIVE SPECIALISTS FOR THE JUKE BOX OPERATORS

The One-Stop with a complete selection of Singles, E.P.'s, 7 inch L.P.'s, Standards and Background Music.

FREE TITLE STRIPS

Immediate Delivery
Mail Orders Our Specialty

OTTO WILKINSON
General Manager

659 Tenth Ave., (212) Circle 6-1234, New York City 36

We Extend to

"CASH BOX"

Our very sincere congratulations on
your 23rd Anniversary

We of the Westchester Operators Guild are very proud and happy
to have Cash Box as our friend.

Our Best Wishes For Your Continued Success.

Westchester Operators Guild Inc.

125 NORTH MAIN STREET
PORT CHESTER, NEW YORK

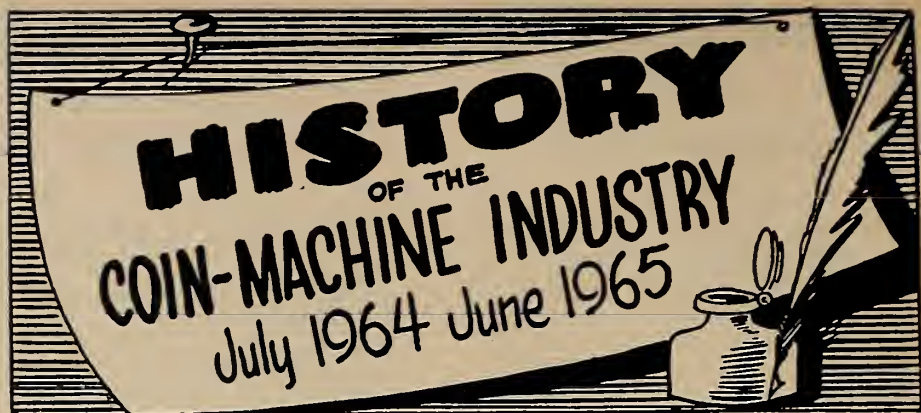

JULY

Pete Petropoulos was appointed Rowe AC Sales Manager succeeding Bob Martin. ★ 300 cigarette operators and guests attended annual outing at Laurels Country Club. ★ Vendo and Kelsey Hayes competed for purchase of Continental APCO and Continental Vending Machine Corp. ★ A drop of 6% was noted for vending machine production during 1963. ★ Eddie Ginsburg, his customers, friends and guests celebrated 30 years of Atlas Music Company success at a lavish Chicago outing. ★ American Shuffleboard's sales representative, Hall McKinley, was laid to rest. ★ The Vendo Company bought the assets of Continental Vending for \$6,500,000. ★ J. H. Keeney and Company moved its equipment and personnel into Chicago's Jennings Building. ★ Lou Casola decided to keep the MOA convention in Chicago for 1965. ★ Williams Mfg. released its new "heat wave" single-player. ★ NAMA lifted its membership ban on music

and amusement operators. ★ United shipped its "tiger" shuffle. ★ John Chapin was named Field Engineering and Training Director by Seeburg. ★ Zach Toms of Liggett & Myers Tobacco died. ★ Betson Vending announced additional expansion at its North Bergen, N.J. headquarters. ★ Frank Ash joined Active Amusement's sales staff. ★ Industrias Riojas, Mexico City based Wurlitzer outlet, announced increased distribution facilities for Latin America. ★ The U. S. Treasury Dept. took initial steps toward alleviating the coin shortage by increasing production at its mints. ★ Seeburg premiered its LP-480 Console before its European distrib network. ★ Nova Apparate completed expansion of its Hamburg office and plant facilities. ★ Wurlitzer appointed Gulf Coast for its Houston distrib. ★ Tel-A-sign's stockholders approved its Scopitone acquisition.

AUGUST

Gil Bailey's Virginia operators set November 20-21 for their annual convention. ★ U. S. Registrar of copyrights submitted Rep. Celler's HR-11947 to remove royalty exemption. ★ State Sales and Service Corp. settled into larger headquarters in Baltimore. ★ Royal Distributing Corp. announced its role in non-coin billiard parlor installations. ★ Exhibit Supply shipped its X500 "Silent Salesman, Jr." ★ Gottlieb released its "Bowling Queen" single-player flipper to the trade. ★ NAMA intro'd its "\$100 Good Merchandising Idea" for its October convention. ★ Mike Stanley opened his Hawaii Rock-Ola outlet with gala open house. ★ Allen Smith was named Vice President of Southern Amusement Company. ★ Chicago Coin introduced its new "Royal Flash" two-player pin, "DeVille" shuffle and "Majestic" big ball bowler. ★ Bally shipped its new "2 in 1" two-player flipper. ★ Modern

Products released its "Satellite" thrill kiddy ride. ★ Seeburg named Ralph Isacksen for its industrial relations vice president-director. ★ Over 400 customers and friends joined Dave Bond in a 40-year anniversary tribute to him and to Trimount Automatic Music. ★ NAMA named Dave Bach for its 1964 convention chairman. ★ Gottlieb shipped its single-player "Majorettes" flipper. ★ Ron Pepple appointed Eddie Morrison for his Northwest sales staff. ★ Western Trails acquired national distribution for Modern's "Satellite" kiddy ride. ★ United released its "Orbit" shuffle alley to the trade. ★ Dave Rosen was honored by Philly's Municipal Veterans Association. ★ Argentina's Jet S.A. Amusement and Vending credited legislative breakthroughs in national games laws to successful p.r. campaign. ★ United shipped its "Polaris" big ball bowler to the trade.

SEPTEMBER

The Seeburg Corporation acquired the assets of United Manufacturing; Sam Stern was named Chief Exec of the new division. ★ Coinbiz veteran Carl Keesling died. ★ Columbia upped its little LP production for ops. ★ Chicago factories completed final preparations for their MOA exhibits. ★ A major legislative victory, spearheaded by John Cooper of the Allied Vending Service, gained legality for pool table operation in Buffalo. ★ Gottlieb intro'd its "Sea-Shore" two-player flipper to games operators. ★ Bally appointed Advance Distributing Company their outlet in eastern Missouri and southern Illinois. ★ Williams premiered its "Riverboat" single player. ★ Seeburg noted a 47% rise in its net earnings for preceding nine month period. ★ The New Jersey Vending Guild formed an operators credit exchange. ★ Veteran operator Rudy Leitgeb, tri-county Coin Machine Association exec., died September 15. ★ Bally released its "Big Day" four player

to the game trade. ★ London stock speculators subscribed heavily to initial shares released on British Exchange by Phonographic Equipment Ltd. ★ NAMA issued its first volume of its Labor Relations Manual. ★ NYSCMA members discussed business economy and proposed legislation at huge Rochester meeting; re-elected Millie McCarthy president. ★ D & R Industries appointed Jack Werbaneth its regional sales manager. ★ Dean McMurdie became general sales manager for the R. F. Jones Company. ★ Rock-Ola factory reps previewed their new phone line-up to their east coast distrib network. ★ Red Wallace was elected president of the West Virginia Music and Vending Association. ★ Cine-Sonic Sound Inc. announced plans to manufacture units to convert juke boxes into audio-visual machines. ★ MOA's Fred Granger asked for closer cooperation between regional and the national association at Ohio ops meeting.

HISTORY OF THE COIN-MACHINE INDUSTRY

July 1964 June 1965

OCTOBER

New Jersey Council president Bill Cannon stressed the necessity for educating local legislators with coin-operated amusement machines during giant state operators conclave. ★ Close to 600 members and friends of New York State's coin-operated machine trade flocked to the Nevele Hotel for a gala weekend outing. ★ American Shuffleboard made a hit with its equipment at Washington's National Recreation Show. ★ Chicago cigarette operators held their first annual dinner dance Oct. 16 at the La Salle. ★ Jack Burns was named field director for the Empire Coin Machine Exchange. ★ National Shuffleboard premiered its "Coronet" coin-operated table lineup. ★ Chicago Coin introduced its "Mustang" two-player to the trade at the MOA show. ★ Automatic Products released its "Candyshop" vendor at the MOA. ★ Gottlieb shipped its "North Star" single-player flipper to its distrib network. ★ Clint Shockey, Royal Distributing exec, unveiled his "Water Polo" amusement console. ★ Nearly

1,000 tradesmen and associates of the coin-operated machine industry trod the exhibit aisles of the MOA exposition at Chicago's Sherman House; Clint Pierce was elected President. ★ Rock-Ola Manufacturing Company and its distributor network, launched their new "Princess Royal" compact phonograph. ★ R. F. Jones acquired Steelmade Inc., can vending equipment manufacturers. ★ George Miller, national association veteran, resigned from his post as MOA's legislative counsel, due to failing health. ★ Elgin McDaniel, veteran Minnesota coin machine operator, died in a fatal car accident October 3rd. ★ Bally released their "All The Way" unique shuffle alley. ★ Bill Poss was elected ICMOA president. ★ Irving Kaye named Ed Ratajack his national sales manager. ★ 10,000 vending machine operators, manufacturers, and distributors broke all records at a giant NAMA exposition; Rock-Ola's single-cup coffee, Rowe's "FiFo", Westinghouse lineup intro'd. ★ Dick Howard was elected NAMA prexy.

NOVEMBER

American Bottlers held their 46th annual meeting Nov. 9-12 at Chicago's McCormick Place. ★ The South Carolina Coin Operators Assn. met Nov. 21-22 for their annual meeting in Columbia. ★ Gottlieb released its "Happy Clown" four-player flipper to pin game markets. ★ ABC Consolidated agreed to a Federal Trade Commission order requiring divestiture of certain of its motion picture theatre concessions and contract rights. ★ MOA execs picked Chicago to host its '65 meeting. ★ The 46th annual convention of the International Assn. of Amusement Parks opened its convention November 29th. ★ NAMA's Hungerford delivered an initial salvo in his association's battle to avert any "non-conforming" coinage proposals by rapping special silver interest groups. ★ Austria's Automatic Machine Federation held its first International Exhibition and Congress Nov. 7 through 10th at Vienna's Kunstlerhaus. ★ Over 550 tradesmen and friends paid honor to Dave Rosen at a Nov. 15th State of Israel testimonial in Philadelphia. ★

Chicago Coin appointed the Sandler Distributing Co. for their distributor in Minnesota, North Dakota and South Dakota. ★ ARA's Paul Weingarten was elected president of the NYAVA. ★ NAMA's Western Conference drew many members of the trade to Los Angeles Nov. 20-22. ★ Al Denver was unanimously elected president of New York City Music Operators' Assn; new location contract was introduced to members. ★ St. Joseph Valley operators held their annual banquet Nov. 18 in South Bend, Indiana. ★ Seeburg introduced their memory programmer for background units. ★ Britain raised its bank loan rate from 5% to 7% in an attempt to curb devaluation of the British pound. ★ Australia announced plans to introduce a decimal system to its currency in Feb. 1966. ★ New York State's Liquor Authority ruled that the installation of coin-operated equipment in taverns was an exception to the regulation calling for a \$100.00 alteration filing fee provided that the equipment didn't require a change in the location's seating arrangement.

DECEMBER

The Mike Stanley Company was appointed distributor for the American Shuffleboard line in Hawaii. ★ Unique Industries, a division of Florida Western Trails, introduced 12 new kiddy rides to the trade. ★ Eddie Ginsburg hosted a gala Christmas party for his Atlas Music Company employees. ★ The Seeburg Corp. launched its discotheque music-dance package featuring its LPC-480 phono with twin speaker combination and custom "Rec-o-dance" little LP's. ★ The Gotham Educational Equipment Company filed patent infringements against several "round" pool table manufacturers in Denver, Colorado. ★ Chicago Coin released its "pop up" novelty game to amusement operators. ★ United shipped its new "Mambo" shuffle alley. ★ "Tournament" big ball bowler was released by Chicago Coin. ★ Williams-United joined personnel forces and consolidated manufacturing and shipping facilities under one roof. ★ Overall cigarette sales for 1964 were noted

to drop 3%. ★ Mar-Tab Vending purchased the Beyer & Brown amusement route based in Daytona Beach. ★ New Jersey Council President Bill Cannon urged all his operators to return all coins to normal channels of distribution as rapidly as possible in an effort to combat the coin shortage. ★ Midway Manufacturing announced plans to begin production on shuffles and bowlers. ★ Williams introduced their new "Zig-Zag" single-player pin game. ★ The Mike Munves Corporation announced the expansion of all services for games operators. ★ The United Kingdom launched its coin convention season at a record-breaking Blackpool Show. ★ Automatic Canteen was selected by the city of Anaheim, California to handle all concession operations for the new Anaheim Stadium. ★ NAMA's special coinage committee held its first meeting in Chicago on Dec. 17th. ★ Midway released its "Rifle Champ" gun target amusement game.

TIME & MONEY SAVER

CLEAN COIN MACHINE MECHANISMS, MOTORS, RELAYS and SWITCHES IN THE FIELD . . . FAST WITH KLEENALL . . .
WON'T BURN OR CONDUCT LEAVES NO OILY FILM CAN'T HARM INSULATION NO OIL OR CARBON TET



needle-nose nozzle on each can gives pin-point spray at hard-to-reach places

THOROUGHLY TESTED BY COIN OPERATORS
FOR FREE SAMPLE & FULL DATA WRITE ON YOUR LETTERHEAD TO:
COLMAN ELECTRONIC PRODUCTS
P. O. Box 2965 Amarillo, Texas 79105

Thank you for your continued support . . .

New York State Coin Machine Association Inc.

Millie McCarthy, Pres.
Mac Douglas, Treas.
Ed Solomon, Sec.
HURLEYVILLE, NEW YORK

Sincerest Congratulations on your 23rd Anniversary
PHONOGRAPH SERVICE CORP.
2436 N. CICERO AVE., CHICAGO 39, ILL.
TEL: NA-2-4100

MICHIGAN OPERATORS

We are as close as your phone, and as always ready to serve you with:
Rowe AMI phones and vendors, Gottlieb Pins, ChiCoin Bowlers and Guns, ABT standard and model Bill Changers, complete line of reconditioned used Music, Games and vendors: Chorm, boll gum, and all other vending merchandise.

MILLER-NEWMARK DIST. CO.
PARTS DISPATCHED BY NEXT BUS TO YOUR TOWN.
For Export Shipments Through Port of Muskegon

Grand Rapids, Michigan
3767 E. 28th St.
949-2030

Detroit, Michigan
5743 Grand River Ave.
TY8-2230

There's a NEW kind of record with a NEW kind of sound

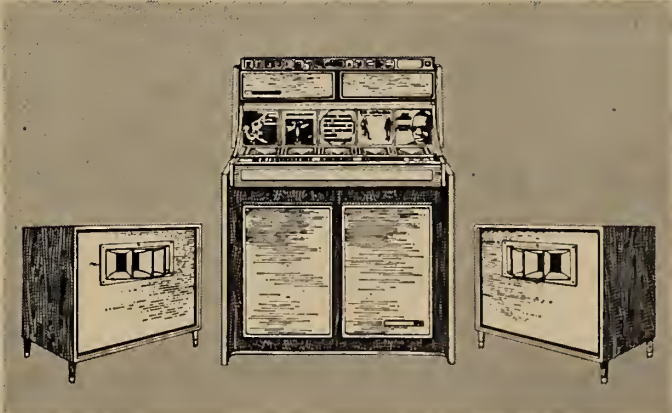

... it's a NEW form of public ENTERTAINMENT!

And it belongs to you . . . alone, compliments of your Seeburg Distributor. The ONLY phonograph showcasing these profitable sounds is the SEEBURG LPC-480.

To hear the sounds (and the facts) just come in and see us, today.

S.L. LONDON MUSIC CO., INC.
3130 W. Lisbon Ave., Milwaukee, Wisc. Tel. (412) 344-3220
LONDON DISTRIBUTING CO.
1100 Northwest 163rd Drive, Miami, Fla. Tel. (305) 621-1415
LONDON DISTRIBUTING CO.
310 Riverside Ave., Jacksonville, Fla. (305) 356-0218
LONDON DISTRIBUTING CORP.
P.O. Box 8471, Fernandez Juncos Station, San Juan, Puerto Rico

WORLD WIDE

offers the world's largest selection of quality PHONOGRAPHS, VENDING and GAMES at MONEY-SAVING LOW PRICES

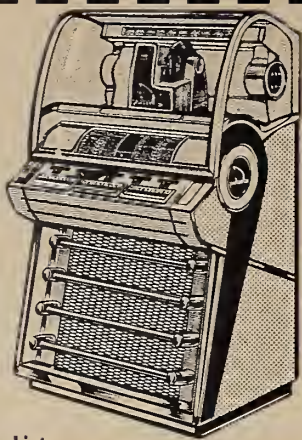

Write for Complete Catalog and Price List



WORLD WIDE distributors

2730 WEST FULLERTON AVE., CHICAGO 47, ILL.
EVerglade 4-2300 CABLE: GAMES - CHICAGO

PHONOGRAPHS

Rockola 1455	\$195.00
Rockola 1465	250.00
Rockola 1468	295.00
Rockola 1475	325.00
Rockola 404	595.00
Rockola 408	650.00
A M I Cont II 100	395.00
A M I Cont I 200	395.00
A M I H 120	195.00
Seeburg VL 200	175.00
Seeburg KD 200	235.00
Wurlitzer 1700	95.00
Wurlitzer 1800	95.00

BOWLERS

Bally Challenger	\$169.50
Bally Bowler 16'	495.00
United Savoy 16'	195.00
United Falcon 16'	195.00
United Alamo 16'	675.00
United Advance 16'	150.00
Chic. Coin Gold Crown	675.00

SHUFFLES

Bally Del Club	\$ 99.50
Bally Official Jumbo	125.00
Bally Super Shuffle	350.00
Bally Big Seven	350.00

MISCELLANEOUS

United Del Baseball	\$195.00	Bally Bucky Horse	\$495.00
Bally Bank Ball	175.00	Bally Sharpshooter	175.00
Bally Champion Horse	395.00		

NOW DELIVERING: BALLY MAGIC CIRCLE, BALLY 50/50, 2 PLAYER ROCKOLA STARLETS, PRINCESS ROYAL & GRAND PRIX II

LAKE CITY AMUSEMENT COMPANY

4533 PAYNE AVENUE CLEVELAND, OHIO Tel. HE 1-4100

G-R-R-R-R-8 BUYS

on completely reconditioned United Shuffles. All Models

DOLPHIN to ULTRA

contact us for low prices:

BANNER SPECIALTY CO. 1641 N. Broad St., Phila. CE 6-5000

WE'VE SWITCHED! to ROWE/AMI

Shaffer Music Co. is the new distributor in Ohio, Michigan, and Kentucky for Rowe Vending Equipment and AMI Phonographs.

Shaffer Music will continue to have a wide selection of excellent used equipment in great operating condition.

See Shaffer first for the best in music and vending.

SHAFFER MUSIC CO.

Columbus, Ohio, 849 North High St., 294-4614

Cincinnati, Ohio, 1889 Central Parkway, 621-6310

Cleveland, Ohio, 21st Ave. at Carnegie, 241-2651

Detroit, Mich., 300 E. Milwaukee, 873-4200

HISTORY OF THE COIN-MACHINE INDUSTRY

July 1964 June 1965



JANUARY

Ed Claffey was appointed general sales manager at Rowe AC. ★ Mike Stanley opened a branch office on L.A.'s Pico Blvd.; Marshall Ames was appointed as the man in charge. ★ The Wurlitzer Co. introduced their Model 2900 phonograph to the music operating trade through open house premieres at their distrib network; new remote wall box was also bowed. ★ Rowe AC factory execs and distribs held a pre-release phono meeting in Miami's Diplomat Hotel. ★ An East and Gulf Coast shipping tie-up caused costly delays in coin machine exports. ★ Milwaukee music ops cited increased collections for 1964 at their January 11th meeting. ★ Struve Distributing was appointed by Seeburg as their equipment outlet in S. Calif. and Arizona. ★ Coin machine and vending veteran Frank Doyle passed away. ★ Columbia released six more little LP's. ★ Seeburg announced record 1964 earnings. ★ The Rowe AC organization premiered their 'Diplomat' Musicconsole

phonograph ★ Central Sales Co. moved to new Houston showrooms. ★ Bally released their "Bullfight" single-player. ★ MOA brass met with coin machine factory owners and reps to plan '65 Trade Show and discuss proposed ASCAP legislation. ★ Marvel Mfg. announced its new "side-mount" scoreboard for shuffleboards. ★ Tape Athon's Anthony toured coinmarkets with his background unit in conjunction with Wurlitzer 2900 phono showings. ★ Columbia Records released a special display rack for merchandising stereo singles and little LP's to music ops. ★ ICMOA convened in Springfield to discuss the Illinois \$10.00 license fee on equipment. ★ Northern Ill. ops met in Chi. ★ Seeburg brought coin-op discotheque to Europe via a Zurich meet. ★ Rowe distribs continued gala open house showings of their 'Diplomat' phono. ★ American tobacco intro'd quarterly payments for cig vending ops.

FEBRUARY

Over 3,000 shatter attendance record at London's A.T.E.; wide variety of new coin-op music and games equipment shown. ★ Lowen Automaten took steps to broaden its distrib effectiveness. ★ Earl Kies was re-elected president of the Recorded Music Service Assn. ★ ChiCoin named State Sales in Md., D.C., Va. and N.C. and Pioneer Sales in Wisconsin as distribs. ★ Large bloc of coin-op table mfr's displayed their home lines at the Nat'l Sporting Goods Show in Chi. ★ Williams shipped 'Pretty Baby' two-player pin. ★ Wiener Bros. Sales relocated HQ to Bklyn. ★ Al Witt was elected president at South Carolina Ops. Assn. ★ Reg Gilchrist was appointed Gen. Mgr. at Universal Music in Toronto. ★ Sparks Specialty was named for Rowe in Atlanta. ★ Gottlieb released "Thoro-Bred" two-player flipper. ★ Seeburg's discotheque sales team scoured nation with package demonstrations. ★ 'Putt-Well' golf

game was intro'd to trade. ★ Struve opened a Los Angeles showroom. ★ Epic Records released 6 more little LP's. ★ Heavy vending representation sparked 'Start Your Own Business Show' in N.Y. ★ NAMA worked toward October Trade Show in Miami. ★ Williams' Lurie conducted amusement game "front money" discussions in many major cities. ★ Conn. Assn. attorney Joseph Burns died. ★ Bally shipped "Border Beauty" bingo. ★ Eastern Music Systems' Marvin Stein was honored by the Allied Jewish Appeal. ★ Trade leaders in N.Y. united with Manpower Development Program officials to establish phonograph mechanic school in Sept. ★ Marvel revamped its plant facilities. ★ Dick O'Connor was appointed Asst. Sales Prom. Mgr. at Wurlitzer. ★ Britain reduced its import tax to 10%. ★ Gorman was named General Sales Rep. at Rock-Ola; Cordero to Sales Coordinator. ★ CMA mounted N.Y. cig tax increase battle.

MARCH

MOA directors wrapped up their mid-year meeting in Washington, D.C. after meeting Congressmen and formulating plans for the September convention. ★ Williams' Bud Lurie pressed his dime-play, front money, program for amusement operators. ★ Seeburg succeeded in reversing the breach of contract suit brought on by a Phoenix, Arizona distributing company. ★ Williams introduced their "Alpine Club" single-player pin game. ★ Bally unveiled their "Sheba" two-player pin which offered three ways to gain free balls. ★ Pepsi-Cola held their bottlers seminar for New York operators March 10-11. ★ Dave Howle was appointed sales director for AVENCO. ★ Westinghouse Automatic Merchandising Division released its WK8-10 coffee vendor. ★ Mike Stanley toasted hundreds of customers and guests to a 2-day bash at his Bellevue, Washington office. ★ The coin division of New York's UJA kicked off their 1965 campaign; Al Miniaci was selected by the committee to be guest of honor. ★ South Dako-

ta's operators held a 20th anniversary birthday celebration and convention in Aberdeen; Darlo Maxwell succeeded John Trucano as president. ★ Rowe AC Manufacturing kicked off their discotheque package starring their "Diplomat" phono; Killer Joe Piro was signed as the program's standard bearer. ★ Baltimore operators mourned the death of General Vending's Irv Blumenfeld. ★ Chicago Coin introduced their "Top Brass" shuffle alley. ★ Southland Engineering released their "Kiddy Railroad". ★ Frank Schroeder became PR representative for Fischer Manufacturing. ★ United released their "Galleon" bowler. ★ American Shuffleboard exhibited equipment at the American Health, Physical Education and Recreation Convention, March 18 through 22, in Dallas. ★ Rowe AC held regional distributor meetings which began March 31; the subject of cold drink machines got priority treatment. ★ New York State cigarette operators set April 1st to begin vending at 40¢.

HISTORY OF THE COIN-MACHINE INDUSTRY

July 1964 June 1965



APRIL

Morris Gisser began a round the world sales trip for his Cleveland Coin Machine Exchange on April 27. ★ Bally Manufacturing issued a fact sheet containing operator service information. ★ Seeburg appointed L & R Distributing for southern Illinois and eastern Missouri. ★ Suren Fesjin of Mondial embarked on a middle eastern sales trip. ★ 250 operators and customers attended a gala open house party at Betson enterprises in North Bergen, New Jersey. ★ Billy Weikel was appointed sales head for Great Lakes and Orbit Engineering. ★ Automatic Canteen gained operating privileges at New York's new Metropolitan Opera House. ★ Jack Burlington of Vendo was named to the NAC Board. ★ NAMA issued formal requests to their members to petition Congress on the industry's standpoint of the coin problem. ★ Midway Manufacturing shipped their "Play Ball" single-player baseball game. ★ Greece banned operation on all amusement games; U.S. exporters were hit hard.

★ Williams introduced their single-player golf game "Hollywood Driving Range". ★ Baltimore County voted down a proposed bill to ban all pin-ball machines. ★ Harry Hoffman was elected president of General Vending by its Board of Directors. ★ Operator sales of New Orleans instituted a new lease program for customers. ★ The eighth international automatic vending exhibition introduced new vending ideas to the British market at London show. ★ Several cigarette manufacturers raised the price on their filter brands. ★ Paul Calamari was appointed Bally Sales Manager. ★ Wurlitzer announced the purchase of the Martin Band Instrument Company. ★ Southeastern Vending opened a Raleigh, South Carolina branch. ★ Robert Harpling was appointed Bally Assistant Sales Manager. ★ Williams premiered their "Double Play" baseball game. ★ Gottlieb shipped their "Hi Dolly" two-player. ★ Bally released their four-player "Band Wagon".

MAY

Chicago Coin introduced their "Big League" two-player baseball game ★ The Bowling and Billiards Institute of America held their 25th meet in New York's Hilton; Fischer, Kaye exhibited ★ Rock-Ola released two new cold can drink dispensers ★ NAMA issued their 1964 report ★ Chicago Coin named C. A. Robinson Company and Badger Sales for L. A. area ★ NAMA termed INCO coinage substitute unsuitable ★ Bally Mfg. introduced their "1965 Bally Bowler" ★ Shaffer Music signed with Rowe AC to distribute their complete line of products in Southern Ohio ★ The 1965 Hanover Trade Fair and 43rd Milan Fair showed off the best side of the industry to the European merchant market ★ Vendo promoted Van Vlack and Kovalick ★ Rock-Ola held open distributor meetings in New York, New Orleans and Chicago to prep for new phono lineup ★ Seeburg offered operators a solution to the ASCAP-royalty problem with the factory's own music licensed and recorded and produced by them and a new rights

agency named COPPS ★ Copyright hearing dates were set for the end of the month; MOA witnesses were selected and ready ★ California's operators association announced the proposed opening of an additional office in S. Calif. ★ New York City coinbiz reps met with members of the City's Manpower Development and Training Program and finalized plans for a juke box mechanic's school to begin in Sept. ★ Ace-Hi Distributing was appointed Wurlitzer outlet in Buffalo ★ Seeburg's Bill Adair traveled far and wide in U.S.A. with the Seeburg juke box operators own music plan ★ Bally issued their parts and supplies catalogue for amusement operators ★ The Wurlitzer Company launched into their discotheque package program in conjunction with the Arthur Murray Dance Studios ★ Tee-Q Industries released their "Thunderbird Raceways" slot car game ★ Gottlieb premiered their "Buckaroo" single-player ★ Bilotta Enterprises gained national distribution for Brad Cue Sticks ★ Alan Kitt joined the sales staff of Empire Coin.

JUNE

Rowe AC dropped all the excise tax on their phonographs. ★ Seevend was appointed Seeburg distributor for S. Ohio, W. Va., & N. Ky. ★ Williams Released the "Moulin Rouge" and the "Pyramid" Shuffle Alley. ★ United offered the industry a free kiddie ride booklet. ★ Vendo Co. received the Dept. of Commerce Export Excellence Award. ★ U. S. Census Bureau cited an 11% rise in value of mfrs'. '64 new machine shipments. ★ Scopitone announced the release of its 1st eight American-made films. ★ Music ops testified at the Copyright Bill hearings. ★ Federal Machine released its Cup Drop Popcorn Vendor. ★ Bally released its "Magic Circle" single player flipper. ★ Ace-Hi was selected to distribute the Rock-ola line. ★ Westchester Operators re-elected Carl Pavesi Pres. for '65-'66. ★ Harry Jacobs, Sr. passed away June 6. ★ Vet-

eran Jersey Op McKim Smith died. ★ Rock-ola celebrated 30 years of successful equipment manufacturing. ★ Rock-ola premiered two new phonographs, the "Grand Prix" and the "Starlet." ★ Stancraft moved their sales HQ to Closter, N. J. ★ Jack Gordon, Seeburg's Pres., brought his company's Phono-Speaker "bargain pack" to Europe. ★ Phono and games displays sparked Paris Fair. ★ National Shuffleboard's Harry Kotler died. ★ "Oasis" Bowler was released by Williams Mfg. ★ State of Texas okayed free play bill. ★ 770 guests pledged 250,000 dollars to shatter the UJA-Coin Machine division record at Al Miniace testimonial in N. Y. ★ All phono Mfrs. reduced sale price to distributors when LBJ signed the excise tax law. ★ Seeburg formed 14 publishing firms in Europe. ★ Empire was named distributor for Bally in Michigan.

TOUSJEUX & NOUVEAUTES,
S. A.
GENEVA, SWITZERLAND

The oldest manufacturers of football games, trade mark "LE NATIONAL," the best European game known.

We are also

Operator and Distributor of Bally's most successful games for Switzerland.

THE HOT BOX

JUKE BOX CONTROL CABLES

Now a complete selection of Juke Box Control Cable for nearly every use.

Phone or write for your low trade prices.

DYNABALL COMPANY
8039 LAWDALE, SKOKIE, ILL. 60076
677-0773 549-5100

Congratulations
to
CASH BOX
on its
22nd Anniversary
NEW YORK STATE OPERATORS GUILD
Headquarters: BEACON, NEW YORK

ACTIVE'S

the choice for

THE LOWEST

PRICES and

BEST EQUIPMENT

ALWAYS

Exclusive Gottlieb and Rock-Ola Distributor for Eastern Penna, So. Jersey and Delaware.

Reconditioned Equipment For Export
ACTIVE Amusement Machines Co.
666 No. Broad Street, Phila. 30, Pa. POplar 9-4495
1101 Pittston Ave., Scranton 5, Penna.



DONNY DUCK



Everybody loves that happy little fellow. Mfr. of the following other rides:

Leo the Lion
Ben Hur Chariot
Derby Pony
Sam the Clown
(See-saw)
Pony Cart

All rides carry one year warranty.

PAUL W. HAWKINS MFG.

3119 E. Pennsylvania
Rt. 7, Box 974L

Phone: 294-1607 Tucson, Arizona 85714

DISCOUNT HOUSE

If you haven't received your
D & R Catalog yet—Drop us a line

"The light that guides the industry"

3323 W. Foster Ave.

D & R INDUSTRIES, CHICAGO, ILL. 60625

Phone: (312) 588-5522



Happy Anniversary

Sincerest and Best Wishes

to

CASH BOX

On Its 23rd Anniversary

MUSIC OPERATORS of NEW YORK, Inc.

NEW YORK, N. Y.

ALBERT S. DENVER, President

U.S. PHONOGRAPH MANUFACTURERS AND DISTRIBUTORS

ROCK-OLA

ROCK-OLA MANUFACTURING CORP.

800 North Kedzie Ave.
CHICAGO, ILL.

(Distributors)

A.M.A. DISTRIBUTORS, INC.
1711 St. Charles Avenue
NEW ORLEANS, LA. 70130

A'S VENDING, INC.
1405 Turtle Creek Blvd.
DALLAS, TEXAS

ACTIVE AMUSEMENT MACHINES CO.
666 N. Broad Street
PHILADELPHIA, PENNA. 19130

ACTIVE AMUSEMENT MACHINES CO.
1101 Pittston Avenue
SCRANTON 5, PENNA.

AMUSEMENT DISTRIBUTORS, INC.
1615 St. Emanuel Street
HOUSTON, TEXAS 77003

ARIZONA AMUSEMENT & VENDING CO.
848 North Fourth Avenue
TUCSON, ARIZONA

BIRD MUSIC DISTRIBUTORS, INC.
124-126 Poyntz Avenue
MANHATTAN, KANSAS 66503

H. B. BRINCK
825-827 East Front Street
BUTTE, MONTANA 59701

BROWN BROTHERS, INC.
7600 Wayzata Blvd.
MINNEAPOLIS, MINN. 55426

CALDERON DISTRIBUTING CO., INC.
423 North Alabama Street
INDIANAPOLIS, INDIANA

VICTOR CONTE MUSIC COMPANY
1001 Lansing Street
UTICA, NEW YORK 13501

EMPIRE COIN MACHINE EXCHANGE
1012 N. Milwaukee Avenue
CHICAGO, ILLINOIS 60622

EMPIRE COIN MACHINE EXCHANGE
7743 Puritan Avenue
DETROIT, MICHIGAN 48238

EMPIRE COIN MACHINE EXCHANGE
1955 South Division Street
GRAND RAPIDS, MICHIGAN 49507

EMPIRE COIN MACHINE EXCHANGE
(c/o HASTINGS DISTRIBUTORS)
6100 W. Bluemond Road
MILWAUKEE, WISCONSIN

RONDEAU SALES—(DIVISION OF
EMPIRE COIN MACHINE EXCHANGE)
102—20th Street
MENOMINEE, MICHIGAN

FLOWER CITY DISTRIBUTORS, INC.
389 Webster Avenue
ROCHESTER, NEW YORK 14609

FRANCO DISTRIBUTING CO., INC.
24 North Perry Street
MONTGOMERY, ALABAMA 36104

GENERAL VENDING SALES CORP.
239-245 W. Biddle Street
BALTIMORE, MARYLAND 21201

GREATER SOUTHERN DISTRIBUTING
COMPANY
321 Edgewood Avenue, S.E.
ATLANTA, GEORGIA 30312

GRECO BROS. AMUSEMENT CO., INC.
Main Street—Box G
GLASCO, NEW YORK 12432

GRECO BROS. AMUSEMENT CO., INC.
1288 Broadway Avenue
ALBANY, NEW YORK

H. Z. VENDING & SALES CO., INC.
1201-1207 Douglas Street
OMAHA, NEBRASKA 68102

J. M. NOVELTY COMPANY
5555 Mahoning Avenue
YOUNGSTOWN 9, OHIO

KINGS DISTRIBUTING COMPANY
330 N. Johnson Street
P. O. Box 976
VISALIA, CALIFORNIA 93277

KINGS DISTRIBUTING COMPANY
2712 West Pico Blvd.
LOS ANGELES 6, CALIFORNIA

KINGS DISTRIBUTING COMPANY
315 North Thorne Avenue
P. O. Box 3227
FRESNO, CALIFORNIA

LAKE CITY AMUSEMENT CO., INC.
4531-4533 Payne Avenue
CLEVELAND, OHIO 44103

B. D. LAZAR COMPANY
1635 Fifth Avenue
PITTSBURGH, PENNA. 15219

LESTOURGEON DISTRIBUTING CO.
2828 South Boulevard
P. O. Box 641
CHARLOTTE, NORTH CAROLINA 28201

MOUNTAIN DISTRIBUTORS
3630 Downing Avenue
DENVER, COLORADO 80205

MUSIC & VENDING CORPORATION
86 Brookline Avenue
BOSTON, MASSACHUSETTS 02215

MUSICAL SALES, INC.
2920 Locust Street
ST. LOUIS, MISSOURI 63103

PATTON MUSIC COMPANY
611 Eye Street
MODESTO, CALIFORNIA

ELI ROSS DISTRIBUTORS, INC.
852 N. W. 71st Street
MIAMI, FLORIDA 33150

ELI ROSS DISTRIBUTORS, INC.
90 Riverside Avenue
JACKSONVILLE, FLORIDA 32202

S & H DISTRIBUTING CO., INC.
1550 Bolinger Avenue
SHREVEPORT, LA. 71103

S & M DISTRIBUTING CO., INC.
1074 Union Avenue
MEMPHIS, TENNESSEE 38104

SANDERS DISTRIBUTING COMPANY
612 Eighth Avenue, South
NASHVILLE, TENNESSEE 37203

SEACOAST DISTRIBUTORS
1200 North Avenue
ELIZABETH, NEW JERSEY 07201

ALBERT SIMON, INC.
587-9 Tenth Avenue
NEW YORK, NEW YORK 10036

M. J. STANLEY COMPANY
309—112th N.E.
BELLEVUE, WASHINGTON

STATE MUSIC DISTRIBUTORS, INC.
3100 Main Street
DALLAS, TEXAS 75226

S. L. STIEBEL COMPANY
635 West Main Street
LOUISVILLE, KENTUCKY 40202

TULSA AUTOMATIC MUSIC COMPANY
739 West 5th Street
TULSA, OKLAHOMA 74127

VENDING MACHINE EXCHANGE
63 Commonwealth Avenue
BRISTOL, VIRGINIA 24201

WALLACE & WALLACE MUSIC, INC.
401 Jones Avenue
OAK HILL, WEST VIRGINIA 25901

ROWE AC

ROWE AC MANUFACTURING
Troy Hills Road
WHIPPANY, NEW JERSEY

(Distributors)

ATLAS MUSIC CO.
2122 N. Western Ave.
CHICAGO, ILL.

AUTOMATIC MUSIC DIST., INC.
900 North Western Ave.
OKLAHOMA CITY, OKLA.

BANNER SPECIALTY CO.
1508 Fifth Ave.
PITTSBURGH 19, PA.

SOUTHERN AMUSEMENT OF ALABAMA,
INC.
3606 Sixth Ave., South
BIRMINGHAM, ALABAMA

BUSH INTERNATIONAL INC.
286 N.W. 29th St.
MIAMI, FLA.

BUSH INTERNATIONAL INC.
60 Riverside Ave.
JACKSONVILLE, FLA.

BUSH INTERNATIONAL, INC.
1725 West Cypress
TAMPA, FLORIDA

BUSH INTERNATIONAL INC.
P.O. Box 8582, Fdez. Juncos. Sta.
SANTURCE, PUERTO RICO

ADVANCE DISTRIBUTING CO.
4710 Delmar Blvd.
ST. LOUIS, MISSOURI

CENTRAL SALES CO.
2104 Leeland Ave.
HOUSTON, TEXAS

GARRISON SALES CO.
1000 W. Washington St.
PHOENIX, ARIZONA

HERMITAGE MUSIC CO.
469 Chestnut
NASHVILLE, TENN.

R. F. JONES CO.
240 Shotwell St.
SAN FRANCISCO, CALIF.

R. F. JONES CO.
1269 So. Figueroa
LOS ANGELES, CALIF.

R. F. JONES CO.
375 South Second, West
SALT LAKE CITY, UTAH

R. F. JONES CO.
2830 W. 9th Ave.
DENVER, COLO.

R. F. JONES CO.
841 Halekauwila St.
HONOLULU, HAWAII

R. F. JONES CO.
309 9th Avenue, North
SEATTLE, WASHINGTON

K. C. SALES AND SERVICE
1926 University Ave.
ST. PAUL 4, MINN.

J. H. LYNCH CO., INC.
1601 So. Gayoso
NEW ORLEANS, LOUISIANA

PIONEER SALES AND SERVICES, INC.
3110 W. Fond du Lac Ave.
MILWAUKEE, WISCONSIN

ROANOKE VEND. EXCH., INC.
4930 W. Broad St.
RICHMOND, VA.

(Continued on page 48)

DAVIS

OFFERS

BIG SAVINGS

BIG SOUND

... and much quality

in the used equipment export field ...

The Davis World Export Corp. guarantee is synonymous with top quality used music and vending equipment the World over. An exclusive Seeburg factory distributor, Davis offers ...

... LOCATION-READY equipment which is steam cleaned and overhauled

... GUARANTEED machines which are electrically and electronically tested

... European AND Puerto Rican Representatives

IN EUROPE
Holland-Belge-Europe
276 Ave. Louise
Brussels, Belgium

IN PUERTO RICO
Cancel Hermanos Inc.
1816 Loiza St.
Santurce, Puerto Rico

Write or visit our representative for
guaranteed quality used equipment

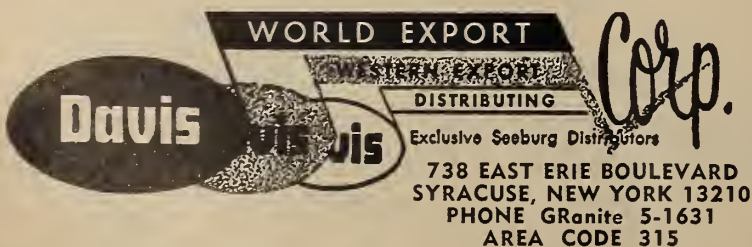

COLUMBIA RECORDS

for greater play and greater profit!

Current best-selling singles

Unmatched Little LP library

All-time "Hall of Fame" hits

Everything's going for

COLUMBIA RECORDS

ATLAS helps you make operating profitable
with
RECONDITIONED SPECIALS GUARANTEED
IN STOCK—SUBJECT TO PRIOR SALE

PIN BALLS — BOWLERS

GOTTLIEB		BALLY	
TROPIC ISLE	\$155	CROSS COUNTRY	\$185
SLICK CHICK	175	CUE-TEASE, 2-PL.	225
GIGI	195	STAR-JET, 2-PL.	275
FLYING CHARIOT, 2-PL.	280	SKY DIVER	245
SHIPMATES, 4-PL.	450	MAD WORLD, 2-PL.	375
WILLIAMS		GRAND TOUR	295
"21"	\$120	2-IN-1, 2-PL.	375
TRADE WINDS	185	HARVEST	325
FRIENDSHIP 7	185	BULL FIGHT	350
SKILL POOL	240	BUS STOP, 2-PL.	395
METRO, 2-PL.	225	BIG DAY, 4-PL.	495
MARDI GRAS, 4-PL.	295	3-IN-LINE, 4-PL.	295
		BONGO, 2-PL.	315

CHICAGO COIN	
SOUTH PACIFIC, 2-PL.	\$365
MUSTANG, 2-PL.	440

UNITED BALL BOWLERS	
FALCON	\$350
SAVOY	295
TIP TOP	295
DIXIE	250
CLASSIC	350

BALLY
ALL-THE-WAY
SHUFFLE ALLEY
LIKE NEW \$350

... plus a big selection of completely reconditioned and refinished Phonographs, Vending Machines and Games for domestic and export sale.



Write for complete 1965 Catalog
Established 1934

ATLAS MUSIC COMPANY

Cable:
ATMUSIC—Chicago

2122 N. WESTERN AVE., CHICAGO 47, ILL. ARmitage 6-5005

**U.S. PHONOGRAPH
MANUFACTURERS
AND
DISTRIBUTORS**

(continued)

SEEBURG

1500 N. Dayton St.
CHICAGO, ILL.

(Distributors)

ADVANCE AUTOMATIC SALES
1350 Howard Street
SAN FRANCISCO, CALIFORNIA 94103

ATLANTIC NEW YORK CORPORATION
843—Tenth Avenue
NEW YORK, NEW YORK 10019

ATLANTIC CONNECTICUT CORP.
171 Park Avenue
EAST HARTFORD, CONN. 06108

ATLANTIC NEW JERSEY CORP.
730 Division Street
ELIZABETH, NEW JERSEY 07201

ATLAS MUSIC COMPANY
2231 Fifth Avenue
PITTSBURGH, PA. 15219

DAVIS DISTRIBUTING CORP.
738 Erie Blvd. East
SYRACUSE, NEW YORK 13210

DAVIS DISTRIBUTING CORP.
1231 Main Street
BUFFALO, NEW YORK 14209

DAVIS DISTRIBUTING CORP.
1056 Broadway
ALBANY, NEW YORK 12204

DAVIS DISTRIBUTING CORP.
319 Alexander Street
ROCHESTER, NEW YORK 14604

DUNIS DISTRIBUTING COMPANY
1003 S. W. Front Ave.
PORTLAND, OREGON 97204

EASTERN DISTRIBUTORS, INC.
1812 Worcester Street
BALTIMORE, MARYLAND 21230

EASTERN MUSIC SYSTEMS CORP.
334 North Broad Street
PHILADELPHIA, PA. 19102

H. A. FRANZ & COMPANY
606 Dennis
HOUSTON, TEXAS 77006

G. K. GABRIELSON & COMPANY, INC.
724 Memorial Drive, S.E.
ATLANTA, GEORGIA 30316

**MR. JOHN P. STOCKSDALE
J & J DISTRIBUTORS, INC.**
1661 West 16th Street
INDIANAPOLIS, INDIANA 46207

L & R DISTRIBUTING, INC.
1901 Delmar
ST. LOUIS, MISSOURI 63103

LIEBERMAN MUSIC COMPANY
257 Plymouth Avenue North
MINNEAPOLIS, MINNESOTA 55411

S. L. LONDON MUSIC COMPANY, INC.
3130 W. Lisbon Ave.
MILWAUKEE, WISCONSIN 53208

MR. S. L. LONDON
LONDON DISTRIBUTING COMPANY
1100 Northwest 163rd Drive
MIAMI, FLORIDA 33169

LONDON DISTRIBUTING COMPANY
310 Riverside Ave.
JACKSONVILLE, FLORIDA 32202

LONDON DISTRIBUTING CORP.
P. O. Box 8471
Fernandez Juncos Station
SAN JUAN, PUERTO RICO 00910

(Continued on page 49)

**There's a NEW kind of record
with a NEW kind of sound**

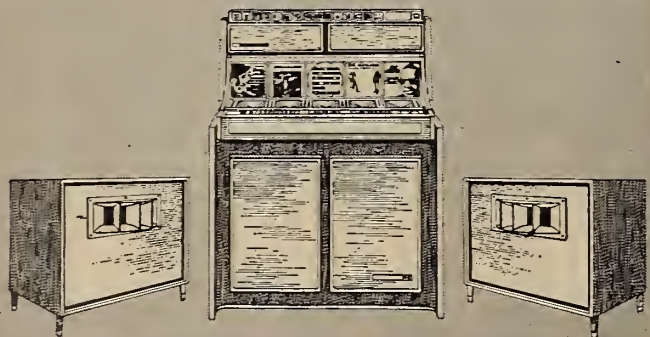

**... it's a NEW form of public
ENTERTAINMENT!**

**And it belongs to you . . . alone, compliments
of your Seeburg Distributor. The ONLY pho-
nograph showcasing these profitable sounds
is the SEEBURG LPC-480.**

To hear the sounds (and the facts)
just come in and see us, today.

Southeastern Vending Distributors, Inc.

601 WOODIS AVE.
NORFOLK, VA.
622-0811

1010 S. SAUNDERS ST.
RALEIGH, N.C.
833-1633

1506 TAYLOR ST.
COLUMBIA, S.C.
253-7565

ROWE AC (Cont'd)

ROANOKE VEND. EXCH., INC.
625 Ohio Ave.
CHARLESTON, W. VA.

ROANOKE VEND. EXCH., INC.
63 Commonwealth Ave.
BRISTOL, VA.

DAVID ROSEN, INC.
855 N. Broad St.
PHILADELPHIA 23, PA.

RUNYON SALES CO.
593 Tenth Ave.
NEW YORK 18, N.Y.

RUNYON SALES CO.
U.S. Route 22—Fadam Rd.
SPRINGFIELD, N. J.

RUNYON SALES CO.
306 Tolland St.
HARTFORD, CONN.

SANTONE SALES CO.
121 Navarro St.
SAN ANTONIO, TEXAS

SHAFFER MUSIC CO.
849 N. High St.
COLUMBUS, O.

SHAFFER MUSIC CO.
2126 E. 21st St.
CLEVELAND, OHIO

SHAFFER MUSIC CO.
1889 Central Parkway
CINCINNATI, OHIO

SHELDON SALES DIST. CORP.
881 Main St.
BUFFALO 3, N.Y.

SOUTHERN AMUSEMENT DIST. CO.
628 Madison Ave.
MEMPHIS 3, TENNESSEE

SOUTHERN AUTOMATIC MUSIC CO.
735 S. Brook St.
LOUISVILLE, KY.

SOUTHERN AUTOMATIC MUSIC CO.
P. O. Box 422
INDIANAPOLIS, IND.

SOUTHERN VENDING CO.
1405 Turtle Creek Blvd.
DALLAS, TEXAS

SPARKS SPECIALTY CO.
842 N. Highland Ave., N.E.
ATLANTA, GA.

SPARKS SPECIALTY CO.
1309 Taylor St.
COLUMBIA, S.C.

TRIMOUNT AUTOMATIC SALES CO.
40 Waltham St.
BOSTON 18, MASS.

W. B. MUSIC CO.
2900 Main St.
KANSAS CITY, MO.

Canada

R. C. GILCHRIST, LTD.
5796 Ferrier St.
TOWN OF MT. ROYAL
MONTREAL, QUEBEC

GILCHRIST VENDING LTD.
76 Densley Ave.
TORONTO, ONTARIO

R. C. GILCHRIST, LTD.
2089 W. Fourth Ave
VANCOUVER, B.C.

U.S. PHONOGRAPH MANUFACTURERS AND DISTRIBUTORS

(continued)

SEEBURG (Cont'd)

MARTIN AND SNYDER COMPANY
13200 West Warren
DEARBORN, MICHIGAN 48126

PHILIP MOSS AND COMPANY
1420 Locust Street
DES MOINES, IOWA 50309

PHILIP MOSS AND COMPANY
309 North 16th Street
OMAHA, NEBRASKA 68110

MUSIC-VEND DISTRIBUTING CO.
100 Elliott, West
SEATTLE, WASHINGTON 98119

O'CONNOR DISTRIBUTING CO. INC.
9030 Directors Row
DALLAS, TEXAS 75247

OPERATORS SALES, INC.
4122 Washington Ave.
NEW ORLEANS, LOUISIANA 70125

SAMMONS-PENNINGTON COMPANY
1049 Union Ave.
MEMPHIS, TENNESSEE 38104

SAMMONS-PENNINGTON-NASHVILLE,
INC.
214 Sixth Avenue South
NASHVILLE, TENNESSEE 37203

SEEVEND, INC.
457 Neilston St.
COLUMBUS, OHIO 43215

SOUTHEASTERN VENDING
DISTRIBUTORS, INC.
1010 South Saunders Street
RALEIGH, NORTH CAROLINA 27603

SOUTHEASTERN VENDING
DISTRIBUTORS, INC.
1506 Taylor Street
COLUMBIA, SOUTH CAROLINA 29201

SOUTHEASTERN VENDING
DISTRIBUTORS, INC.
601 Woodis Avenue
NORFOLK, VIRGINIA 23510

R. F. STENSTROM, INC.
210 Mokauea Street
HONOLULU, HAWAII 96819

STRUVE DISTRIBUTING CO. INC.
963 Folsom Avenue
SALT LAKE CITY, UTAH 84104

STRUVE DISTRIBUTING CO. INC. OF
COLO.
50 Rio Grande Blvd.
DENVER, COLORADO 80023

STRUVE DISTRIBUTING CO. INC.
1403 West Pico Blvd.
LOS ANGELES, CALIFORNIA 90015

STRUVE DISTRIBUTING CO. INC.
1900 E. McDowell Road
PHOENIX, ARIZONA 85006
SUTHERLAND DISTRIBUTING CO. INC.
2710 McGee Trafficway
KANSAS CITY, MISSOURI 64108

SUTHERLAND DISTRIBUTING CO. OF
JOPLIN
501 Wall St.
JOPLIN, MISSOURI

SUTHERLAND DISTRIBUTING CO. OF
WICHITA
1135 N. Washington St.
WICHITA, KANSAS 67214

SUTHERLAND DISTRIBUTING CO. INC.
Northwest Fourth & Lee Sts.
OKLAHOMA CITY, OKLAHOMA 73102

SUTHERLAND DISTRIBUTING CO.
1343 S. Staples
CORPUS CHRISTI, TEXAS

SUTHERLAND DISTRIBUTING CO.
3902 Pershing
EL PASO, TEXAS 79903

SUTHERLAND DISTRIBUTING CO.
226 S. Flores Street
SAN ANTONIO, TEXAS 78204

W. S. DISTRIBUTING, INC.
126 Lincoln
BRIGHTON, MASS. 02135

WORLD WIDE DISTRIBUTORS
2732 West Fullerton
CHICAGO, ILLINOIS 60647

Canada

WESTERN AUTOMATIC VENDING LTD.
499 Commercial Drive
VANCOUVER 6, B.C., CANADA

"GUS" WINTER LIMITED
Portugal Cove Road
P. O. Box 1450
ST. JOHN'S, NEWFOUNDLAND

WURLITZER

THE WURLITZER CO.
NORTH TONAWANDA, N.Y.

(Distributors)

MICKEY ANDERSON AMUSEMENT CO.
314 East 11th Street
ERIE 5, PENNSYLVANIA

ANGOTT DISTRIBUTING COMPANY, INC.
2616 Puritan Avenue
DETROIT 38, MICHIGAN

ARKANSAS DISTRIBUTING COMPANY
316 West Second Street
HOPE, ARKANSAS

B & B DISTRIBUTING COMPANY, INC.
777 Main Street
BUFFALO, NEW YORK

BANNER SPECIALTY COMPANY
1641 North Broad Street
PHILADELPHIA 22, PENNSYLVANIA

BILOTTA ENTERPRISES, INC.
224 North Main Street
NEWARK, NEW YORK

BILOTTA ENTERPRISES, INC.
1226 Broadway
ALBANY 4, NEW YORK

TOP MUSIC CO.
501 West Fayette Street
SYRACUSE, NEW YORK

BRADY DISTRIBUTING COMPANY
1900 West Morehead Street
CHARLOTTE 8, NORTH CAROLINA

BRANDT DISTRIBUTING COMPANY, INC.
1809-11 Olive Street
ST. LOUIS 3, MISSOURI

CENTRAL DISTRIBUTING COMPANY
1209 Douglas Street
OMAHA 2, NEBRASKA

CLEVELAND COIN MACHINE EXCHANGE,
INC.
2029 Prospect Avenue
CLEVELAND 15, OHIO

CLEVELAND COIN MACHINE EXCHANGE,
INC.
1827 Adams Street
TOLEDO, OHIO

COMMERCIAL MUSIC COMPANY, INC.
1550 Edison Street
DALLAS 7, TEXAS

CONSOLIDATED MUSIC COMPANY
1062 North Seventh Street
LAS CRUCES, NEW MEXICO

CO-OPERATIVE DISTRIBUTING COMPANY
221 East Market Street
LOUISVILLE 2, KENTUCKY

(Continued on page 50)

COLORAMA[®]



A coin operated multiple select theatre.

For the first time a complete program of machine and film suited for the coin entertainment industry.

- 40 selections
- Full Hi-Fidelity color and sound
- Library of famous American artists performing in American films
- Continuous film production guaranteed
- Extensive film library
- Automatic cartridge film operation with no rewind time
- Remote wall box operation possible
- \$1980* (plus film)
- A money maker for any coin operator

Exclusive territories available to select operators.

Contact:

COLORAMA[®] DIVISION

INTERSPHERE DEVELOPMENT CORPORATION

6 BURNS AVE., HICKSVILLE, L. I., N. Y., PHONE: 516 681-0410

Delivery scheduled for January 1966.

*Price subject to change without notice.

29 years

of honest, dependable
service to the
coin machine trade...

...and through the years with

SEEBURG

the industry's finest name!



DISTRIBUTORS FOR

WILLIAMS ☆ BALLY ☆ CHICAGO COIN

ATLAS MUSIC CO.

2231 Fifth Ave.

Pittsburgh, Pennsylvania

Tel. 471-1704

U.S. PHONOGRAPH MANUFACTURERS AND DISTRIBUTORS (continued)

WURLITZER (Cont'd)

CRUZE DISTRIBUTING COMPANY, INC.
1101 West Washington Street
CHARLESTON 2, WEST VIRGINIA

CULP DISTRIBUTING COMPANY
614 West Sheridan Avenue
OKLAHOMA CITY 2, OKLAHOMA

DIAMOND COIN MACHINE EXCHANGE,
INC.

609 Woodis Avenue
NORFOLK 10, VIRGINIA
DRACO SALES COMPANY
2005 West Alameda
DENVER 23, COLORADO

F.A.B. DISTRIBUTING COMPANY, INC.
3927 Navy Boulevard
PENSACOLA, FLORIDA

GULF COAST DISTRIBUTING CO.
6205 Gulf Freeway
HOUSTON, TEXAS 77023

LEW JONES DISTRIBUTING CO., INC.
1311 North Capitol Avenue
INDIANAPOLIS 2, INDIANA

LEW JONES DISTRIBUTING CO., INC.
(NATIONAL COIN MACHINE EXCHANGE)
1411-13 Diversey Boulevard
CHICAGO 14, ILLINOIS

MID-WEST DISTRIBUTORS
709 Linwood Blvd.
KANSAS CITY, MISSOURI

MUSIC DISTRIBUTING COMPANY
1945 Fifth Avenue
PITTSBURGH 19, PENNSYLVANIA

MUSICAL DISTRIBUTORS CORPORATION
2714 Beverly Road
BROOKLYN 25, NEW YORK

MUSICAL DISTRIBUTORS CORPORATION
841 Tenth Avenue
NEW YORK, NEW YORK

NORTHWEST SALES COMPANY
3150 Elliott Avenue
SEATTLE 1, WASHINGTON

NORTHWEST SALES COMPANY OF
OREGON
1040 S. W. Second Avenue
PORTLAND 4, OREGON

PEACH STATE MUSIC COMPANY
624 New Street
MACON, GEORGIA

PEACH STATE MUSIC COMPANY
729 Lady Street
COLUMBIA, SOUTH CAROLINA

PEACH STATE MUSIC COMPANY
1040 Boulevard, S. E.
ATLANTA 12, GEORGIA

REDD DISTRIBUTING COMPANY
80 Coolidge Hill Road
WATERTOWN 72, MASSACHUSETTS

(Continued on next page)

THE BIG EVENT OF 1965 IS THE 15TH ANNUAL

MOA CONVENTION and TRADE SHOW

Pick Congress Hotel, Chicago
Saturday • Sunday • Monday
September 11th, 12th and 13th



- * More Exhibit Hours
- * Outstanding Industry Seminar
- * Fabulous Banquet and Show
- * Regional Association Meetings
- * Carnival of Ideas
- * Distinguished Guests

*Two floors of exhibitors representing all segments of
the coin-operated music and amusement industry.*

Music Operators of America • 228 N. La Salle Street • Chicago, Illinois 60601

U.S. PHONOGRAPH MANUFACTURERS AND DISTRIBUTORS

WURLITZER (cont'd)

ROCK CITY DISTRIBUTING CO., INC.
615 Murfreesboro Road
NASHVILLE 10, TENNESSEE

ROTH NOVELTY COMPANY
54 North Pennsylvania Avenue
WILKES-BARRE, PENNSYLVANIA

ROYAL DISTRIBUTING, INC.
1210 Glendale-Milford Road
CINCINNATI 15, OHIO

ROYAL DISTRIBUTING, INC.
1112 N. High Street
COLUMBUS 1, OHIO

SANDLER DISTRIBUTING COMPANY
236 Girard Avenue North
MINNEAPOLIS 11, MINNESOTA

SOUTHERN MUSIC DISTRIBUTING CO.,
INC.
503 West Central Avenue
ORLANDO, FLORIDA

SOUTHERN MUSIC DISTRIBUTING CO.,
INC.
2465 Harper Street
JACKSONVILLE, FLORIDA

STATE SALES AND SERVICE
CORPORATION
1825 Guilford Avenue
BALTIMORE, MARYLAND 21202

UNITED, INC.
1907 North Third Street
MILWAUKEE 2, WISCONSIN

UNITED DISTRIBUTORS, INC.
902 West Second Street
WICHITA 12, KANSAS

VALIANT AMUSEMENT, INC.
3129 East McDowell Road
PHOENIX, ARIZONA

THE WURLITZER COMPANY
2920 West Pico Blvd.
LOS ANGELES 6, CALIFORNIA

THE WURLITZER COMPANY
154 South Van Ness Avenue
SAN FRANCISCO 3, CALIFORNIA

THE WURLITZER COMPANY
832 Barronne Street
NEW ORLEANS, LOUISIANA

**PHONOGRAPH
DISTRIBUTOR
LISTS BEGIN
ON PAGE 46**

Australian Jubilee To Launch New Gaming Machines

LONDON—The Australian firm Jubilee Products are about to launch two new "pub playing" machines, specially designed for this semi-new market and in accordance with the stake and payment requirements of the Betting & Gaming law. One is a 3d play machine the other a two pulls for 6d model. Harold Smith the firms U.K. Manager reports that after five years in this country business continues to grow and that the demand for the companies product has never been greater.

Jubilee will again be exhibiting at the 1965 Club Trade Fair to be held in Brighton at the towns new exhibition hall from 28th September to 2 October.

U.S. AMUSEMENT MACHINE MANUFACTURERS AND DISTRIBUTORS

ALL-TECH
ALL-TECH INDUSTRIES, INC.
950 West Twentieth St.
HIALEAH, FLORIDA

AMERICAN
AMERICAN SHUFFLEBOARD CO.
210 Paterson Plank Rd.
UNION CITY, N.J.
(West Coast)
1423 So. Western Ave.
LOS ANGELES, CALIF.
(Distributors)

ADVANCE DIST. CO.
4710 Delmar Boulevard
ST. LOUIS, MISSOURI 63106

AMERICAN SHUFFLEBOARD SALES COM-
PANY OF NORTHERN CALIFORNIA
911—53rd Avenue
OAKLAND, CALIFORNIA

AMERICAN SHUFFLEBOARD SALES COM-
PANY OF OHIO
1219 East Third Street
DAYTON 2, OHIO

AMERICAN SHUFFLEBOARD SALES COM-
PANY OF SEATTLE
3144 Elliott Avenue
SEATTLE 1, WASHINGTON

AMERICAN SHUFFLEBOARD SALES COM-
PANY OF HOUSTON
254 W. Gray Street
HOUSTON, TEXAS

BETSON ENTERPRISES
3726 Tonnelle Avenue
NORTH BERGEN, NEW JERSEY

BELLETINI MUSIC COMPANY
501 Byrd Street
COALGATE, OKLAHOMA

BORDER SUNSHINE NOVELTY COMPANY
2919 Fourth Street North West
ALBUQUERQUE, NEW MEXICO

CENTRAL SALES INCORPORATED
91 Dennis
HOUSTON, TEXAS 77006

CLEVELAND COIN MACHINE EXCHANGE
INC.
2029 Prospect Avenue
CLEVELAND, OHIO

COIN A MATIC INC.
1208 Farnam Street
OMAHA, NEBRASKA

COMMERCIAL MUSIC COMPANY, INC.
1550 Edison Street
DALLAS, TEXAS

CULP DIST CO.
614 West Grand
OKLAHOMA CITY, OKLAHOMA

DIAMOND COIN MACHINE EXCHANGE
COMPANY
609 Woodis Avenue
NORFOLK, VIRGINIA

DUNIS DISTRIBUTING COMPANY
ANCHORAGE, ALASKA

EASTERN DISTRIBUTORS INCORPORATED
1812 Worcester Avenue
BALTIMORE, MARYLAND

JACK EISER SALES
820 Shick Street
FORT WAYNE, INDIANA

EMPIRE COIN MACHINE COMPANY
1012 Milwaukee Avenue
CHICAGO, ILLINOIS

FAIRLANE SALES
Box 721
WAYNE, NEW JERSEY

FRANCO DISTRIBUTING COMPANY
Box 927
24 North Perry Street
MONTGOMERY, ALABAMA

GAMES SALES COMPANY
262 South Camilla
MEMPHIS 4, TENNESSEE

GILCHRIST VENDING LIMITED
5796 Ferrier Street
MONTREAL, QUEBEC, CANADA

GILCHRIST VENDING LTD.
76 Densley Ave.
TORONTO 15, ONTARIO, CANADA

GILCHRIST VENDING LTD.
2089 West Fourth Avenue
VANCOUVER 9, B.C., CANADA
R. C. GILCHRIST (VANCOUVER) LIMITED
7221-104th Street
EDMONTON, ALBERTA, CANADA

GILCHRIST VENDING LIMITED
265 Princess Street
WINNIPEG 2, MANITOBA, CANADA

GINSBERG MUSIC COMPANY
205 North Main Street
ROSWELL, NEW MEXICO

HERMITAGE MUSIC COMPANY
469 Chestnut Street
NASHVILLE 10, TENNESSEE

E. M. HOUSE SALES
307 Meadow Road
SYRACUSE, NEW YORK

R. F. JONES CO.
2830 West Ninth Avenue
DENVER, COLORADO

R. F. JONES CO.
375 South Second West
SALT LAKE CITY, UTAH

R. F. JONES CO.
240 Shotwell Street
SAN FRANCISCO, CALIFORNIA

KLOPP NOVELTY COMPANY
312 North Ninth Street
READING, PENNSYLVANIA

B. D. LAZAR
1635 Fifth Avenue
PITTSBURGH, PENNSYLVANIA

LeSTOURGEON DISTRIBUTING
COMPANY
2828 Boulevard South
CHARLOTTE, NORTH CAROLINA

MID WEST DISTRIBUTING COMPANY
3850 Mariposa Street
DENVER 11, COLORADO

MILLER NEWMARK DISTRIBUTING
COMPANY
3767 East 28th Street
GRAND RAPIDS 2, MICHIGAN

MILLER NEWMARK DISTRIBUTING
COMPANY
5743 Grand River Avenue
DETROIT 8, MICHIGAN

MONROE COIN MACHINE EXCHANGE
INC.
2423 Payne Avenue
CLEVELAND 14, OHIO

PHILIP MOSS COMPANY
1420 Locust Street
DES MOINES, IOWA

PHILIP MOSS COMPANY
309 North 16th Street
OMAHA NEBRASKA

MOUNTAIN DISTRIBUTING COMPANY
3630 Downing Street
DENVER, COLORADO

MIKE MUNVES CORPORATION
577 Tenth Avenue
NEW YORK, NEW YORK

NYACK SLATE DISTRIBUTING COMPANY
112 Railroad Avenue
NYACK, NEW YORK

LOUIS OSTERMANN
101 S. Goodwin Street
PEORIA, ILLINOIS

O'CONNOR DIST. CO., INC.
9030 Directors Row
DALLAS, TEXAS 75247

PEACH STATE MUSIC CO.
130 Blvd. N.E.
ATLANTA, GEORGIA

PEACH STATE MUSIC CO.
1913 Huger St.
COLUMBIA S. C.

PHILADELPHIA AMERICAN
SHUFFLEBOARD CO.
1511 Spring Garden St.
PHILADELPHIA, PA.

PEACH STATE MUSIC CO.
624 New Street
MACON, GEORGIA

(Continued on page 52)

SKI 'N' SKORE

WRITE FOR LITERATURE

BUILD TRAFFIC
IN ANY LOCATION
AND PROFIT
FOR THE OPERATOR



A proven dynamic, prestige, profit maker for coin game operators. Opens new markets... Widely accepted in prime locations, where other coin games may not be permitted. Hundreds of games now in use!

See us at the MOA and NAMA Shows. For more information, call or write.

GAMES
DIVISION OF DUKANE CORPORATION
St. Charles, Illinois 60174

BIGGER PROFITS
NOW WITH

TROUBLE-FREE

COIN-OP POCKET BILLIARD TABLES

by National of New Jersey

"CORONET"

Manufactured
to exacting
professional
standards.

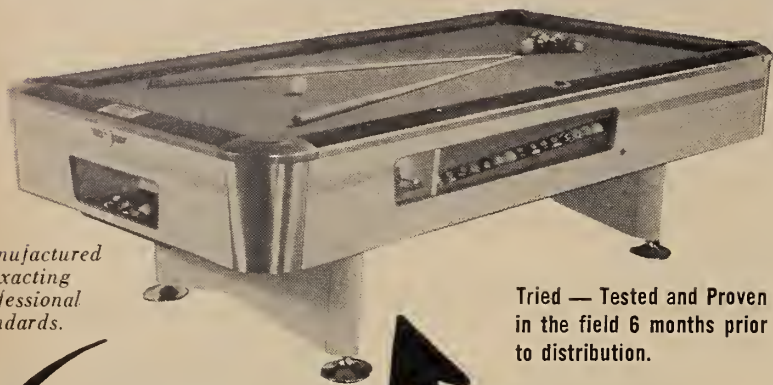

Tried — Tested and Proven
in the field 6 months prior
to distribution.

- PICTURE WINDOW BALL VIEWER
- DECORATOR DESIGNED FOR BEAUTY
- SOLID SLATE BED
- TROUBLE-FREE UPKEEP

NOW AVAILABLE

4 x 8 Reg.	4 1/2 x 9
52" x 92"	46" x 78"

SHUFFLEBOARDS
by National of N. J.

For the best in Shuffleboards ask about the "Lucky 13 Star-Lite" and the "Astro-Lite" . . . these models by National of N. J. are NEWER than NEW! Built with PROFIT PERFORMANCE in mind.

Write for FREE Color Brochure or Phone 201-672-9100 for Coin-Op, Professional, Billiard Lounge, and Home Tables.



NATIONAL

Shuffleboard & Billiard Co. of N. J.
31 MAIN ST., E. ORANGE, N. J.

U.S. AMUSEMENT MACHINE Manufacturers and Distributors

(Continued from page 51)

PURVEYOR SHUFFLEBOARD CO.
4322 No. Western Ave.
CHICAGO 18, ILLINOIS

RAYCAR, INC.
7812-14 Hamilton Ave.
PITTSBURGH, PA.

ROCK CITY DIST. CO.
615 Murfreesboro Rd.
NASHVILLE, TENN.

RUNYON SALES CO.
36 Legal Street
NEWARK, N. J.

ROYAL DISTRIBUTING CO., INC.
1210 Glendale-Milford Rd.
CINCINNATI, OHIO

ROANOKE VENDING EXCHANGE, INC.
4930 W. Broad St.
RICHMOND 26, VIRGINIA

ROANOKE VENDING EXCHANGE
625 Ohio Ave.
CHARLESTON, W. Va.

ROTH NOVELTY CO.
55 No. Pennsylvania Ave.
WILKES, BARRE, PA.

S & M SALES CO., INC.
1074 Union Avenue
MEMPHIS, TENN.

SOUTHERN AMUSEMENT CO.
628 Madison Ave.
MEMPHIS, TENN.

SOUTHERN MUSIC CO.
2465 Harper St.
JACKSONVILLE, FLA.

SOUTHERN MUSIC CO.
1922 North Dixie Highway
HOLLYWOOD, FLORIDA
HERB MULLENS
RESIDENT AGENT

SPARKS SPECIALTY CO.
1309 Taylor Street
COLUMBIA, S. C.

M. J. STANLEY CO.
309-112th N.E.
BELLEVUE, WASHINGTON

DAN STEWART CO.
140 E. 2nd South
SALT LAKE CITY, UTAH

STRUVE DIST. CO.
50 Rio Grande Blvd.
DENVER 23, Colo.

SHELDON SALES DIST CO.
881 Main
BUFFALO, N.Y.

SOUTHERN MUSIC CO.
503 W. Central Ave.
ORLANDO, FLORIDA

SOUTHERN MUSIC CO.
2209 E. Broadway
TAMPA, FLORIDA

STATE MUSIC CO.
3100 Main St.
DALLAS, TEXAS

STRUVE DIST. CO.
963 Folsom Avenue
SALT LAKE CITY, UTAH

SUTERLAND DIST. CO.
709 N.W. 4th Street
OKLAHOMA CITY, OKLA.

SUTERLAND DIST. CO.
1135 N. Washington St.
WITCHITA, KANSAS

SUTERLAND DIST. CO.
601 Wall Street
JOPLIN, MISSOURI

SUTERLAND DIST. CO.
2710 McGee Trfwy.
KANSAS CITY, MISSOURI

SUTERLAND DIST. CO.
226 S. Flores
SAN ANTONIO 5, TEXAS

SANTONE SALES
121 Navarro Street
SAN ANTONIO, TEXAS

TRI STATE AMUSEMENT CO.
Bedford Street
MANCHESTER, N. H.

TULSA ANOMATIC MUSIC CO.
789 W. 5th Street
TULSA, OKLAHOMA

WALLACE DIST. CO.
P.O. Box 75
205 N.E. 1st Avenue
MINERAL WELLS, TEXAS

WILCOX MUSIC CO.
211 S. Walnut Street
PINE BLUFF, ARKANSAS

**AUTO-
PHOTO**

AUTO-PHOTO CO.

3300 Central Ave.
LOS ANGELES, CALIF.

Write for Distributor Information

BALLY

BALLY MANUFACTURING CO.

2640 Bemont Ave.
CHICAGO, ILL.

(Write Direct For Distributor Information)

CHICOIN

**CHICAGO DYNAMIC
INDUSTRIES, INC.**

1725 Diversey Blvd.
CHICAGO, ILL.

(Write For Distributor Information)

DALE

DALE ENGINEERING CORP.

6744 Orizaba Ave.
LONG BEACH, CALIF.

DOLAN

JACK DOLAN CO.

7001 Canoga Ave.
CANOGA PARK, CALIFORNIA

DUNCAN

DUNCAN SALES CORP.

737 Carnegie Ave.
CLEVELAND, OHIO

DUKANE

**GAMES DIVISION DUKANE
CORP.**

ST. CHARLES, ILLINOIS

EXHIBIT

EXHIBIT SUPPLY CO.

4218-30 W. Lake St.
CHICAGO, ILL.

(Write For Distributor Information)

FISCHER

FISCHER SALES COIN DIVISION

1208 Ridge Road
McHENRY, ILL.

(Write For Distributor Information)

FRANTZ

J. F. FRANTZ MFG. CO.

1940 W. Lake St.
CHICAGO, ILL.

(Distributor List Available On Request)

IT MAKES CENTS . . .



. . . Wurlitzer's 2900 Phonograph that is!
Cash in on the profitable
world of the Wurlitzer
Golden Bar at —

MUSICAL DISTRIBUTORS CORP.

841 Tenth Avenue, New York, N.Y.

JU 6-7782

2714 Beverly Road, Brooklyn, N.Y.

UL 6-7720

(Continued on page 53)

U.S. AMUSEMENT MACHINE Manufacturers and Distributors

(Continued from page 52)

GOTTLIEB

D. GOTTLIEB & CO.
1140-50 N. Kostner Ave.
CHICAGO, ILL.

(Distributors)

ACTIVE AMUSEMENT MACHINES CO.
666 N. Broad St.
PHILADELPHIA, PA.

ADVANCE AUTOMATIC SALES CO.
1350 Howard St.
SAN FRANCISCO, CALIF.

ALL COIN AMUSEMENTS CO.
2495 N.W. 77th Terrace
MIAMI, FLA.

BANNER SPECIALTY CO.
1508 Fifth Ave.
PITTSBURGH, PA.

BILOTTA DIST. CO.
224 N. Main St.
NEWARK, N.Y.

BIRMINGHAM VENDING CO.
540 Second Ave.
BIRMINGHAM, ALA.

CLEVELAND COIN MACHINE EXCH.
2029 Prospect Ave.
CLEVELAND, O.

CULP DIST. CO.
614 W. Sheridan
OKLAHOMA CITY, OKLA.

FRANCO DIST. CO.
24 No. Perry St.
MONTGOMERY, ALA.

GARRISON SALES CO.
100 W. Washington
PHOENIX, ARIZ.

GENERAL VENDING SALES CORP.
245 W. Biddle St.
BALTIMORE, MD.

H. Z. VENDING & SALES CO.
1205 Douglas St.
OMAHA, NEB.

R. F. JONES CO.
240 Shotwell St.
SAN FRANCISCO, CALIF.

R. F. JONES CO.
2830 W. 9th Ave.
DENVER, COLO.

R. F. JONES CO.
1269 So. Figueroa St.
LOS ANGELES, CALIF.

R. F. JONES CO.
375 South 2nd West
SALT LAKE CITY, UTAH

B. D. LAZAR CO.
1635 Fifth Ave.
PITTSBURGH, PA.

LIEBERMAN MUSIC CO.
257 Plymouth Ave., N.
MINNEAPOLIS, MINN.

S. L. LONDON MUSIC CO., INC.
3130 W. Lisbon
MILWAUKEE, WIS.

MILLER-NEWMARK DIST. CO.
5743 Grand River Ave.
DETROIT, MICH.

MILLER-NEWMARK DIST. CO.
3767 28th St. S.E.
GRAND RAPIDS, MICH.

IRVING MORRIS, INC.
145 Frelinghuysen Ave.
NEWARK, N.J.

MORRIS NOVELTY CO.
3007 Olive St.
ST. LOUIS, MO.

MUSIC VEND DIST. CO.
100 Elliott Ave., West
SEATTLE 99, WASHINGTON

MUSIC VEND DISTRIBUTING CO.
1003 S. W. Front
PORTLAND, OREGON

MUSIC VEND DISTRIBUTING CO.
West 811 Second
SPOKANE 4, WASHINGTON

NATIONAL COIN MACHINE EXCH.
1411 W. Diversey Pkwy.
CHICAGO, ILL.

NEW ORLEANS NOVELTY CO.
1055 Dryades St.
NEW ORLEANS, LA.

ROYAL DIST. CO.
1210 Glendale-Milford Rd.
CINCINNATI, OHIO

SANDERS DIST. CO.
612-8th Ave. So.
NASHVILLE, TENN.

STATE MUSIC DISTRIBUTORS
3100 Main Street
DALLAS, TEXAS

SOUTHERN AMUSEMENT CO.
628 Madison Ave.
MEMPHIS, TENN.

STATE MUSIC DISTRIBUTORS
3100 Main St.
DALLAS, TEX.

S. L. STIEBEL GAMES CO., INC.
635 West Main St.
LOUISVILLE, KENTUCKY

TRIMOUNT COIN MACHINE CO.
40 Waltham St.
BOSTON, MASS.

UNITED EAST COAST CORP.
583 10th Avenue
NEW YORK, N. Y.

W. B. MUSIC CO.
2900 Main St.
KANSAS CITY, MO.
Export

JUDD DISTRIBUTING CO.
1140-50 N. Kostner Ave.
CHICAGO, ILL.

(See foreign representative listing
elsewhere)

Canada

LANIEL AMUSEMENT INC.
151 Rockland Ave.
Town of Mont Royal
MONTREAL 3, QUEBEC, CANADA

MONARCH C. M. CO.
211 Rupert Ave.
WINNIPEG, MAN., CANADA

GREAT LAKE

GREAT LAKES EQUIPMENT CO.
1208 N. Ridge Rd.
McHENRY, ILLINOIS

HAWKINS

PAUL HAWKINS CO.
3119 E. Pennsylvania Ave., Rt. 7
TUCSON, ARIZONA

IRVING KAYE

IRVING KAYE CO., INC.
363 Prospect Place
BROOKLYN, N. Y.

(Write For Distributor Information)

JENNINGS

JENNINGS MFG. CO.
4309 W. Lake St.
CHICAGO, ILL.

Export Representative:
MAR-MATIC SALES CO.
1009 E. Baltimore St.
BALTIMORE, MD.

MARVEL

MARVEL MANUFACTURING CO.
2849 West Fullerton
CHICAGO, ILLINOIS

(Continued on page 54)

- DOUBLE STANDARD -



COMPACT
BIG UNIT MONEY-MAKERS
THAT TAKE LESS THAN
1/3 THE SPACE
REQUIRED BY A POOL TABLE

ONE TO FIVE BANKS ADD UP TO SIX COMPLETELY NEW GAMES
ON A SINGLE DOUBLE BOARD
SOUND COMPLICATED? NOT AT ALL! ONCE YOU SEE IT
YOU'LL UNDERSTAND. ONCE YOU TRY IT YOU'LL KNOW

You Can Bank On
V-BACK PROFESSIONAL
SHUFFLEBOARD

MANUFACTURED BY
PROTOCISION ENGINEERING

INCORPORATED
1000 E. McNichols Road DETROIT, MICHIGAN 48203

**A NEW CONCEPT
WITH ACTION
AS BIG AS
THE PLAYER'S
IMAGINATION**

REVOLUTIONARY NEW AMUSEMENT GAMES

Pool Table Pictures p. 31-37

Pins and Shuffles p. 39-41

Phonograph Pictures p. 23-30

In the Tulsa, Oklahoma Area Check First With TULSA AUTOMATIC MUSIC CO.

(Established in 1952)

739 W. 5th TULSA, OKLAHOMA Phone: LU. 4-4775
HEADQUARTERS FOR ALL TYPES OF USED COIN MACHINES

Write for Complete List of Current Equipment Prices

ASK FOR
R. C. HOGARD, President **DALE RORIE, Mgr.**
Exclusive Distributors for:
ROCK-OLA MFG. **VALLEY SALES CO.**
AMERICAN SHUFFLEBOARD

ALL-TECH

The Home Table
That Homeowners
Ask For!

- Laminated exterior plywood chassis
- Redwood mica rails, pearl inserts
- White mica aprons
- 100% natural rubber rails
- Gold anodized aluminum trim
- Heavy duty self-adjusting legs
- Built-in scoring counters
- No assembly—set on legs, bolt down

GOLD CREST

ACE 8

4' x 8'

6-Pocket

**GULLEY RETURN
TABLE**



Shipping Wt. 375 lbs.

The same selling features in our coin line apply to the All-Tech home line . . . and this means big sales for you. All-Tech is designed for eye appeal and this is what helps sell the home field!

ALL-TECH Industries Inc.

950 West 20th Street Hialeah, Florida Tel: TUxedo 8-7551

U.S. AMUSEMENT MFR'S AND DISTRIBUTORS

(Continued from page 53)

MIDWAY

MIDWAY MFG. CO.
10136 Pacific Ave.
FRANKLIN PARK, ILL.

ANNIVERSARY SALE!

Completely Reconditioned Guaranteed

Bally

Hootenanny	\$225
Star Jet (2-PI)	275
2 In 1 (2-PI)	345
Mad World (2-PI)	345
Bus Stop (2-PI)	395
Sheba (2-PI)	445

Gottlieb

Gigi	\$245
Sunset (2-PI)	265

BOWLERS AND ARCADES

Bally

Strike Bowler 14'	\$ 75
Trophy Bowler 14'	145
Lucky Alley 14'	145
Official Jumbo Shuffle 8 1/2'	145
Lucky Shuffle 8 1/2'	145
All the Way (2-PI) shuffle 8 1/2'	295
(New Floor Sample)	

Chicago Coin

Six Game Shuffle Bowler 8'	\$145
----------------------------	-------	-------

United

Big Bonus Shuffle 8 1/2'	\$145
Lineup Shuffle 8 1/2'	145
Sunny Shuffle 8 1/2'	145

MUSIC

Rock-Ola 1448	\$195
Rock-Ola 1468	295
Rock-Ola 1488	445
AMI J-120-E	345
Seeburg 161	495
Wurlitzer 2410-5	395
Wurlitzer 2810-4	695
Wurlitzer 2810-1	695

RUSH DEPOSIT BAL. C.O.D. OR SIGHT DRAFT.

MICKEY ANDERSON AMUSEMENT COMPANY

314 East Eleventh Street
Erie, Pennsylvania
PHONE: 452-3207

MILLS

MILLS INTERNATIONAL
35 Mercer St.
NEW YORK, N.Y.

MUTOSCOPE

INTERNATIONAL
MUTOSCOPE CORP.
11-12 44th Avenue
LONG ISLAND CITY, NEW YORK

(Write For Distributor Information)

EXCLUSIVE EXPORT REP.:
BELAMEX VENDING INTL.

51 Madison Ave.
NEW YORK CITY, N.Y.

NATIONAL

NATIONAL SHUFFLEBOARD
CORP.

31 Main St.
EAST ORANGE, N.J.

NYACK

NYACK SLATE CO.

Railroad Ave.
NYACK, N.Y.

ORBIT

ORBIT ENGINEERING CO.

4050 S.W. 14th Ave.
FT. LAUDERDALE, FLORIDA

PATTERSON

L. T. PATTERSON DISTRIBUTORS

10 Rockwood Bldg.
CINCINNATI, OHIO

PROTOSION

PROTOSION ENGINEERING
CORP.

1000 E. McNichold Rd.
DETROIT, MICHIGAN

SOUTHLAND

SOUTHLAND ENGINEERING INC.
1657 Euclid St.
SANTA MONICA, CALIF.

SPACE

SPACE MFG. CO.
5203 Raynor Ave.
LINTHICUM, MARYLAND

SUN-GLO

SUN-GLO SHUFFLEBOARD
SUPPLIES INC.
113 Heckel St.
BELLEVILLE, N. J.

STANDARD

STANDARD-HARVARD
METALTYPER
1318 NORTH WESTERN AVE.
CHICAGO, ILL.

TEE-Q

TEE-Q RESEARCH MFG. CO.
EUDORA, KANSAS

URBAN

URBAN INDUSTRIES INC.

715-17 West Main
LOUISVILLE 2, KENTUCKY

(Write For Distributor Information)

U.S. BILLIARDS

U. S. BILLIARDS INC.
Amityville, N.Y.

VALLEY

VALLEY SALES CO

333 Morton St.
BAY CITY, MICH.

(Write For Distributor Information)

WILLIAMS

WILLIAMS ELECTRONIC
MANUFACTURING CORPORATION

3401 No. California Ave.
(Div. of Seeburg)

(Write For Distributor Information)

ROYAL

DISTRIBUTING, INC.
1210 Glendale-Milford Rd.
Cincinnati 15, Ohio

COLUMBUS ADDRESS:
1112 NORTH HIGH STREET

Please direct all inquiries to
our Cincinnati address.

PHONE:
Area Code 513 • 771-4250
Ask for Harold or Clint

YOU'VE NEVER SEEN GAMES SO CLEAN!

America's Most Diversified
Distributor Offers You the
Widest Selection of Music-
Games-Vending in the Busi-
ness!

Factory Distributors for:

AUTO-PHOTO • BALLY
CHICAGO COIN • FISCHER
GOLD MEDAL PRODUCTS
GOTTLIEB • IRVING KAYE
KEENEY • MIDWAY
WURLITZER • VALLEY

WRITE, WIRE OR CALL TODAY FOR
INFORMATION ON LATEST EQUIP-
MENT AND PRICE LIST. WE'LL ADD
YOUR NAME TO OUR MONTHLY
MAILING.

ROYAL HAS THE LARGEST
SUPPLY OF USED BOWLERS
IN THE U. S. (BOTH 16' &
13'). CHOICE OF AS IS OR
A-1 CONDITION.

AMUSEMENT
MACHINE
MANUFACTURER
LIST BEGINS
ON PAGE 51

IT'S HERE
FRIDAY 3th



DON'T TRUST TO LUCK—

get lucky with the only combination
records and movies machine. It's two
machines in a single unit—it's

FILMOTHEQUE—
DISCOTHEQUE

For Info—Write/Wire/Phone

Exclusive Rowe AMI Distributor
Ea. Pa. - S. Jersey - Del. - Md. - D.C.

DAVID ROSEN, INC.

855 N. BROAD ST., PHILA., PA. 19123
Phone: (215) CEnter 2-2900

SLUGGER...

Counter Game

1c, 5c or 10c play.
Size: 18" x 12" x 8"
Weight, 25 lbs.
Natural wood cabi-
net. Polished
chrome fittings.

\$54.50

f.o.b. Chicago



SPECIALS!
BILLIARD SUPPLIES

5-Oz. Bumper Pool Balls (10)... \$ 9.00
2 1/8" Balls, 1-15 w/Cue Ball... 12.50
2 1/2" Balls, 1-15 w/Cue Ball... 14.00
48" Cues \$ 1.50 ea.
52" Cues \$1.95 ea.; 25 1.50 ea.
57" Cues \$2.95 ea.; 33.00 dz.
Plastic Triangles, 2 1/4" 1.00
6-Hole Cue Rack 5.00
Billiard Chalk, Gr. 3.50

We carry complete line of Pool
Supplies—Write for list.

1/3 deposit, bal. C.O.D. or S.D.

ELECTRIC SCOREBOARDS

Coin operated for shuffleboards.

15, 21 and/or 50 points. (Horse-
collar). OVERHEAD double-faced
model on chrome stands com-
plete with coin box.

\$169.50

f.o.b. Chicago

SIDEMOUNT MODEL — 15-21
points only. Complete with
chrome stands and scoring but-
tons. Walnut Formica cabinet.
Large coin box. Other features.

\$249.50

f.o.b. Chicago

MARVEL Mfg. Co.

2849 W. Fullerton

Chicago, Ill. 60647

Phone: Dickens 2-2424

Mr. Operator! Here's the low-priced high-earner you've been waiting for!

FLYING EIGHT RACEWAYS

Coin-operated raceway skill game earning up to \$4.00 per hour on test locations!



\$595⁰⁰

Suggested
Operator
List Price

International Mfg., Inc., makers of fourteen miniature raceway models ranging in sizes up to 52' x 27' has taken the most profitable play and service features of its nationally known raceways line and engineered them into beautiful mahogany cabinets measuring only 4 feet by eight feet. Scaled racers designed for commercial use, thirty feet of track in each lane (2 lanes), timers with a range of settings, 25¢ meters,

numbered lanes and super-sensitive hand controls for maximum player skill which never heat up in the hand. Rheostat, race track and car has its own color—one set for "red" racer, another for the "blue"—easily distinguishable for simplicity of two-player performance. Flying Eight Raceways is designed with minimum service in mind . . . constructed to sustain weights up to 250 lbs. Each game is virtually indestructible.

PRODUCTION FACILITIES

I.M.I. will begin its accelerated quality control production this week stepping up from present production volume to 100 FLYING EIGHT RACEWAYS each day. Distributors note . . . there should be no delivery problem regardless of the size of individual orders, now or later.

DISTRIBUTOR TERRITORIES NOW AVAILABLE!

While several distributor franchises have already been issued, some choice territories are still offered to coin machine distributors. Inquiries invited.

Call KI 2-2133 Collect!
EUDORA, KANSAS

LEGAL IN EVERY TERRITORY!

The principals of International are familiar with the laws of every state. FLYING EIGHT RACEWAYS are LEGAL EVERYWHERE!

Immediate Delivery Anywhere In the United States. Overseas Buyers Cable for Information.

WRITE • WIRE • CALL FOR
FURTHER INFORMATION

- FLYING EIGHT RACEWAYS are shipped in two cartons—maximum fifteen minute assembly from carton to operation!
- Each FLYING EIGHT RACEWAYS game shipped complete in every respect—CARS, TRACK, POWER-PACKS, RHEOSTATS, VARIABLE VOLTAGE TRANSFORMERS, 25¢ COIN METERS, ready for location operation 15 min. after arrival!
- Shipping wt. 320 lbs. 4' by 8'-29 inches high. Operates on 115-115 volt.
- Fits into floor space smaller than required for most pool tables! Beautiful enough to place in any location and strong enough to take it!
- Operator tested and approved on locations.



International Manufacturing, Inc.

900 East Highway 10
Eudora, Kansas 66025 • KI 2-2133

Ruffler & Walker Praise 'Starlet'



GORDON WALKER

R & W have completed deals with two Brewery chains and have sited 6d play machines in nearly 400 locations.

They are also selling several 3d play lines with 20-1 payouts including the new Keeney upright "Crazy Gang," with payouts up to 1/- in cash and Gold Awards value 5/-. Also Games upright "3d Wild Ball" with payout up to a maximum of 20 disks which are replayable.

R & W have also taken on the Australian Fruit machine Aristocrat lines including the Bar; Belle, 3d play, with 1/- payout and 5/- Gold Award.

Blackpool Show To Bow Nov. 30th

BLACKPOOL—The fifth Northern Amusement Equipment and Coin Operated Machine Exhibition is scheduled to take place this year on November 30th, December 1st and 2nd at its usual venue The Olympia, Winter Garden, Blackpool.

Contrary to rumours that the event would not take place this year the organisers Jack D. Rose (Exhibitions) Ltd. informs us that plans are well advanced. A number of exhibitors from previous years have increased their demand for space including Phnographic Equipment Co. Ltd. Mayfield Automatic Ltd. and Thomas Automatic Co. Ltd. Several new firms will also be exhibiting for the first time.

The exhibition will be opened by The Worshipful The Mayor Alderman, Tom Joyce, J.P. Floor space of up to 20,000 square feet is available.

LONDON—Importers and sole U.K. Distributors for Rock-Ola, Ruffler and Walker have this year introduced the new 'Starlet,' 100% American made and produced in Chicago to compete with the low priced continental machines. The 'Starlet' maintains the Rock-Ola standard of mechanism but the 'frills' have been streamlined to cut cost in order that the machine can sell at virtually the same price as its continental counterparts.

The Starlet is meeting with tremendous success and Ruffler & Walker report a waiting list of up to a month.

Following the amendments to the Betting and Gaming bill Ruffler & Walker have introduced a whole range of new lines and machines with a trend toward 6d play with a 10 to 1 payout rather than 3d play with a 20-1 payout. Gordon Walker told the Cash Box that experience shows that the punter of today expects to pay 6d for pintables, Juke Boxes & Fruit machine play.



California Clippings

Our recent editorial in connection with Italy's expected lifting of restrictions on amusement equipment after October 1st has "phonorow" buzzing with the good news. Less significant, but still a subject for discussion here, is the recent robbery at King Distributors where the Capitol Sales Company's cigarette truck was stolen. It was located three days later but money and cigarettes totalling \$2000 in losses were missing. Harold Chapman, who reported the loss, also told us that he's just returned from a trip thru Blythe, Riverside, Indio and San Diego and that the "juke box" business, though strong in the outlying areas, is still best in L.A. at the moment. . . . The M. J. Stanley Co. held a sales meeting recently at the Cabana Hotel in Palo Alto, Calif with Mike Stanley of Washington, Lou Mohr of Oregon, along with Marshall Ames and Bob Huffman of the local office attending. A new division of responsibilities will have Bob heading the Stancraft line and Marshall in charge of music and games. Both men will devote most of their time to the road and personnel will be added to the Stancraft sales department. Reason is that "sales have been so fantastic that expansion is necessary." . . . Chuck Klein at R. F. Jones reports in with the news that summer business is holding up well with Bill Gray on another trip to Arizona and Ron Schimmel calling on the local customers. Mr. R. F. Jones visited the office from San Francisco following a weekend stay at his Palm Springs retreat. Katie Walsh of the parts department is vacationing in Idaho and Montana. . . . Buddy Robinson is raving about the new Columbia album release and told us he heard from sales manager Teddy Rosenberg that the fall package will be even more sensational—"with artists like Streisand, Williams, Dylan, Gorme, Lawrence and Conniff—how can they miss?" He also told us that Alex Hassilev, who is now a single performer as well as one-third of The Limelighters, dropped by with Mike Borchetta, R.C.A.'s promo rep., to check sales on Hassilev's latest Victor single. Hazel and Shirley Dennison of the sales and shipping departments at California Music are vacationing in Las Vegas and Idlewild Mountain resort. . . . Britt Adelman at Paul Laymon infos that the first carload of the new Bally "50-50" pin game is gone and the second shipment might also be sold out by the time you read this. Paul Laymon entertained Mr. and Mrs. Cecil Edwards, visiting from Germany along with friends in town from Tuscon, Arizona. And Charles Daniels, we hear, is enjoying a brief vacation and we'd guess he's fishing somewhere since that's Charles' favorite pastime. . . . Sonny Lomborg reports that with phonos and pool tables moving at a good clip he's just hired a new man, John Threewit, who'll be assisting in the processing of phonos. Jack and Dorothy Leonard celebrated their 25th wedding anniversary a few weeks ago which means they've been married just two years longer than the Cash Box family—we're celebrating our 23rd this week. Dorothy and Jack celebrated at the Knollwood Country Club in Granada Hills with Jack's dad coming in from Chicago to give them a grand party with 90 friends attending the silver anniversary banquet. . . . George Muraoka at Simon tells us that the distributing firm is now handling the "Alltech" eight foot home pool table and expects it to become an outstanding sales attraction. Due to the recent sales spurt in the parts department Art Spencer has been transferred from the office to assist Joe Merel and Norm Drake has been added to the office staff. George also informed us that Bob Umeda, shop foreman, is in the northwest on a two week fishing trip. . . . Jerry Wallace dropped by at Luenhagen's this past week to spin his latest for Mercury "Twelve Little Roses" and Katie feels that this one has good "juke box potential." . . . Leo Simone at Badger Sales tells us that they have a new foreign game, both German and Italian made, called "Foosball" and that Bill Happel has just returned from the northwest with the news that business is "unbelievable" on this game. The new Gottlieb "Hi-Dolly" two player pin game is now in the showroom at Badger for all to see but Leo is travelling again—this time to Las Vegas where he's calling on ops. Speaking of ops, there have been quite a few along "phonorow" lately including Walter Hemple—San Fernando, Pete Shupp—Downey, Larry Hansford—Lompoc, Al Martinez—Santa Maria, Walter Cook—Palos Verdes, Dick Kanold—Oxnard and Harold Sharkey—Huntington Beach.



UPPER MID-WEST MUSINGS

The Walter Witt family are taking off next week for a few days up north for some good bass fishing. . . . Gabby Clausiau, Grand Rapids, in town taking in the Twin-Baltimore series and staying over the week end. . . . Mr. & Mrs. Pete Wornson and family are driving to San Francisco for a couple of weeks stopping off at several places of interest. . . . Fred Norberg, Manakato, in Canada with a few friends getting in some good fishing. . . . The Gene Clennon's have just returned from a two week vacation, driving to New York and taking in the World's Fair. . . . Mr. & Mrs. Ernest Woytossek and family in town over the weekend visiting friends and relatives. . . . Sam Sigel of the Lieberman Music Co. taking the week off and with Mrs. Sigel are driving to the upper Peninsula for a week's vacation. . . . Mr. & Mrs. Arndt Peterson, in town for the day and taking in the baseball game. . . . Art Berg, Fairmont, Minn. in town for a few hours picking up parts and records. . . . Ralph Sanders, Pine City, and Joe Weber, Blue Earth, in town for the day picking up parts and records. . . . Roy Stone and service man Fritz, in the cities for the day . . . as was Cab Anderson of Hudson.



Happy Birthday This Week To:

Martin J. Bromley, Honolulu, Hawaii. . . . Marjorie H. Stambaugh, W. Palm Beach, Fla. . . . Roy Westerlund, Red Oak, Ia. . . . Wm. R. Happei, Jr., L.A., Calif. . . . Mrs. Ben Hofer, New Braunsfels, Texas. . . . Samuel Weinberger, Indianapolis, Ind. . . . Marshall Thompson Cornelius, Abilene, Texas. . . . Lewis C. Sgank, Kalamazoo, Mich. . . . O. R. Kilburn, Bellows Falls, Vt. . . . Geo. Prock, Dallas, Texas. . . . Ted Rubenstein, Chgo, Ill. . . . James A. Crover, Perth Amboy, N.J. . . . David Berson, Harrisburg, Pa. . . . Walter C. Knack, Dixon, Ill. . . . Robert B. Young, L.A., Calif. . . . Joe F. Floyd, Anderson, S.C. . . . Victor Ostergren, Gary, Ind. . . . Peter Nastasi, New Orleans, La. . . . Kenneth Tom, Montreal, Canada. . . . John P. Christy, Det., Mich. . . . John T. Quinn, Troy, N.Y. . . . Steve Brancalone, Det., Mich. . . . Sydelle Blatt, Miami, Fla. . . . James F. Tolisano, Hartford, Conn. . . . John R. Spink, Woodfibre, B.C., Canada. . . . Alfred D. Harper, Las Cruces, N. Mexico. . . . Carl A. Gualano, Chgo, Ill. . . . Sarkis Anthony, Columbus, Ohio. . . . Wm. Joseph, Zanesville, West Grove, Pa. . . . Chas. A. Robinson, L.A., Calif. . . . Budge Wright, Portland, Ore. . . . Wm. W. McCallum, Dallas, Texas. . . . Gerald J. Martell, Providence, R.I.

If you are reading someone else's copy of
Cash Box
why not mail this coupon today!

CASH BOX
1780 BROADWAY
NEW YORK, N. Y. 10019

Enclosed find my check.

- \$15 for a full year (52 weeks) subscription (United States, Canada, Mexico)
- \$30 for a full year (Airmail United States, Canada, Mexico)
- \$30 for a full year (other countries)
- \$45 for a full year (Airmail other countries)

(Check One)

- I AM A DEALER
- ONE STOP
- DISTRIB
- RACK JOBBER
- PUBLISHER
- RECORD CO.
- DISK JOCKEY
- COIN FIRM
- OTHER

NAME

FIRM

ADDRESS

CITY STATE ZIP #

Be Sure To Check Business Classification Above!

U. S. Distributors and Jobbers LISTED BY STATES

ALABAMA

Birmingham
 Birmingham Vending Co., 540 2nd Ave., N.
 H. C. Clarkson, 2003 Crestmont Dr.
 Jefferson Music Co., 19th & 7th
 Southern Amusement Dist., 3606 6th Ave. S.
 Wolfe Dist. Co., 2003 Crestmont Dr.

Montgomery
 Franco Distribution Co., P.O. Box 927 or
 24 N. Perry St.

ALASKA

Anchorage
 M. J. Stanley Co., P.O. Box 256

Fairbanks
 Alaska Music Co., Box 1234
 Dunis Dist. Co.

ARIZONA

Phoenix
 Amco Leasing, Inc., 2040-B North 16th St.
 City Music Co., 4502 N. 32nd St.
 Copper State Amusements, 921 N. 6th St.
 Jim Finnerty, 2051 27th Place
 Garrison Sales Co., Inc., 1000 W. Washington
 Minthorne Music Co., Inc., P.O. Box 16170
 Struve Dis Co. Inc., 1900E McDowell Road
 Valiant Amuse. Inc., 3129 E. McDowell Rd.

Safford
 Gila Elec. & Music Co., 406 Main St.

Tucson
 Arizona Amusement & Vending Co., 848 No.
 4th Ave.
 Falcon Automatic, 727 So. Campbell Ave.
 Paul W. Hawkins, Route 7—Box 974-L,
 3119 East Pennsylvania

ARKANSAS

Fayetteville
 Tri-State Sales Co., 315 Rollston St.

Hope
 Arkansas Distributing Co., 316 W. 2nd St.

Little Rock
 Little Rock Amusement Co., 105 W. 13th St.
 Standard Aut. Dist. Co., 805 Broadway

Pine Bluff
 211 S. Walnut St.

CALIFORNIA

Los Angeles
 Amco Music & Vending, Inc., 2251 West
 Pico Blvd.
 American Coin Mach. Co., 2962 W. Pico
 Blvd.
 American Shuffleboard Co. Inc., 1423 S.
 Western Ave.
 Badger Sales Co., Inc., 2251 W. Pico Blvd.
 Irving Bromberg Co., 8313 1/2 W. 3rd St.
 R. F. Jones Co., 1269 So. Figueroa
 Kings Dist. Co., 2712 West Pico Blvd.
 Duarte Int. Sales Co., 835 E. 31st St.
 The Seeburg Dist. Co., 2920 W. Pico Blvd.
 C. A. Robinson & Co., 2301 W. Pico Blvd.
 Paul A. Laymon, Inc., 1429 W. Pico Blvd.
 Simon Dist. Co., 2833 W. Pico Blvd.
 E. F. Stanton & Co., 2736 W. Pico Blvd.
 Struve Dist. Co. Inc., 1403 West Pico Blvd.
 The Wurlitzer Co., 2920 W. Pico Blvd.
 Weymouth Dist. Co., 2525 W. Pico Blvd.

Fresno
 Kings Dist. Co., 315 North Thorne Ave.,
 P.O. Box 3227

Modesto
 Patton Music Co., 611 Eye St.

San Francisco
 Advance Automatic Sales Co., 1350 Howard
 St.
 Emarcy Dist. Co., 813 Folsom St.
 Golden Gate Novelty Co., 2293 Mission St.
 Huber Dist. Co., 1118 Howard St.
 R. F. Jones Co., 240 Shotwell St.
 Nobro Novelty Co., 142 Dore St.
 Charles I. Perry Co., 15 Harriet St.
 The Wurlitzer Co., 154 South Van Ness Ave.

Santa Rosa
 Coin Machine Service, Inc., 322 Wilson St.

Turlock
 Patton Music Co., 132 So. Center St.

Visalia
 Kings Dist. Co., 330 N. Johnson St.

Oakland
 A.S.S. Co. of No. Calif., 911—53rd Ave.

COLORADO

Denver
 Draco Sales Co., 2005 W. Alameda Ave.
 J. R. Harris Co., 3650 Tejon St.
 R. F. Jones Co., 2830 W. 9th Ave.
 Midwest Music Co., 3850 Mariposa St.
 Modern Dist. Co., 3222 Tejon St.
 Mountain Distributors Co., 3630 Downing St.
 Struve Distrib. Co. Inc., 50 Rio Grand Blvd.
 Thompson Dist. Co., 1314 Pearl St.

CONNECTICUT

Hartford
 General Amusement Game Co., 187 Park St.
 Reliable Coin Machine Co., 184-188 Windsor
 St.

East Hartford
 Atlantic New York Corp., 171 Park Ave.
 P.O. Box 806
 Runyon Sales Co., 306 Tolland St.

Somers
 Florade Syrup Corp., Eleanor Rd.

FLORIDA

Jacksonville
 Bush International, 60 Riverside Ave.
 S. L. London Distributing Co. of Jackson-
 ville, 310 Riverside Ave.
 Southern Music Dist. Co. Inc., 2465 Harper
 St.
 Eli Ross Distributors, 90 Riverside Ave.

Miami
 All Coin Amusements Co., 2495 N.W. 77th
 Terrace
 Bush International, 286 N.W. 29th St.
 London Dist. Co., 1100 Northwest 163 Dr.
 Eli Ross Dist. Inc., 852 N.W. 71st St.
 Schwartz Dist. Co., 1800 S.W. 17th St.
 William Blatt, 7525 E. Treasure Dr., Miami
 Beach, Fla.

Orlando
 Southern Music Dist. Co. Inc., 503 W. Cen-
 tral Ave.
 S. L. Stibel Co. Inc., 635 W. Main St.

Pensacola
 F.A.B. Dist., Co. Inc., 3927 Navy Blvd.

Tampa
 Bush International, 1725 W. Cypress
 Southern Music Co., 2209 E. Broadway

GEORGIA

Atlanta
 Friedman Amusement Co., 1235 Techwood
 Dr. N.W.
 G. K. Gabrielson & Co. Inc., 724 Memorial
 Dr. S.E.
 Greater Southern Dist. Co., 321 Edgewood
 Ave., S.E.
 National Uni-Pak, 534 Armour Circle
 Peach State Music Co., 1040 Blvd. S.E.
 Robinson Dist. Co., 321 Edgewood Ave. S.E.
 Sparks Specialty Co., 842 N. Highland Ave.
 N.E.
 Variety Dist. Co., 585 Grant St. S.E.

Macon
 Heath Dist., 3253 Vineville Ave.
 Peach State Music Co., 624 New Street

HAWAII

Honolulu
 Hawaiian Amusement Ltd., 2248 S. King St.
 R. F. Jones Co., 841 Halekauaia St.
 R. F. Stenstrom, Inc., 210 Mokauea St.
 Service Games, Inc., 210 Mokauea St.

Wahiawa, Oahu
 Auto. Vend. Mach. Co., P.O. Box 186

NEW MEXICO

Albuquerque
 Border-Sunshine Nov. Co., 2919 4th St.,
 N.W.

Las Cruces
 Consolidated Music Co., P. O. Box 86

Roswell
 Ginsberg Music Co., 205 No. Main St.

NEW YORK

Albany
 Bilotta Enterprises, Inc., 1226 Broadway
 Davis Dist. Co., 1056 Broadway
 Greco Bros. Amuse. Co. Inc., 1288 B'way.
 Ave.
 Universal Vendors, 788 Broadway

Binghamton
 Binghamton Amusement Co. Inc., 4
 Florence St.

Brooklyn
 American Vending Co., 2684 Coney Island
 Ave.
 Herman Dist. Co. Inc., 1505 Coney Island
 Ave.
 Musical Distributors Corporation, 2714
 Beverly Road

Buffalo

B & B Distributors, 777 Main St.
 Clare Enterprises, Inc., 5939 Main St.
 Davis Dist. Corp., 1231 Main St.
 Sheldon Sales, Dist. Corp., 881 Main St.
 N. J. Steinke Co., 731 Main St.

Elmira

Joy Automatic, 108 E. Church St.

Glasco

Greco Bros., Box 94

Glen Falls

Witham Enterprises & Asso., 20 Cunning-
 ham Ave.

Great Neck

L.I. National Sales, 243 N. Blvd.

Hudson Falls

Henry C. Knoblauch & Sons, 7 Broad St.

Newark

Bilotta Enterprises, 224 N. Main St.

New York

Atlantic New York Corp., 843 Tenth Ave.
 R. H. Belam, 51 Madison Avenue
 Crescent Amusement Devices, 841 10th Ave.
 Lipsky Dist. Corp., 607 Tenth Ave.
 Dave Lowy & Co., 602 Tenth Ave.
 Mike Munves Corp., 577 Tenth Ave.
 Mondial Comm. Corp., 330 5th Ave.
 Musical Distributors Corp., 841 Tenth Ave.
 Runyon Sales Co., 593 Tenth Ave.
 Seaboard New York Corp., 843-849 Tenth
 Ave.
 Albert Simon, Inc., 587 Tenth Ave.
 United East Coast Corp., 583 10th Ave.
 West Side Dist. Corp., 612 Tenth Ave.
 Wiener Sales Corp., 539 Tenth Ave.

Rochester

Davis Dist. Corp., 319 Alexander St.
 Flower City Dist. Inc., 738 Erie Blvd.

Syracuse

Davis Corp., 738 Erie Blvd., E.
 E. M. House Sales, 307 Meadow Rd.
 Rex-Bilotta Dist. Co., 501 West Fayette St.

Utica

Victor Conte, 1001 Lansing St.

MICHIGAN

Buchanan

Fabiano Amuse. Co., 109 Liberty Ave., P.O.
 Box 189

Dearborn

Martin and Snyder Co., 13200 W. Warren

Detroit

Angott Dist. Co., 2616 Puritan Ave.
 Empire C. M. Co., 7743 Puritan Ave.
 Gay-Coin Distributors, 4866 Woodward Ave.
 Henry C. Lemke, 1047 E. Grand Blvd.
 Miller-Newmark Dist. Co., 5743 Grand River
 Music Systems, Inc., 14561 Livernois
 Weidman Nat'l. Sales Co., 5911 4th Ave.

Grand Rapids

E. & R. Sales Co., 1732 Monroe, N.W.
 Empire Coin Machine Exchange, 1955 South
 Miller-Newmark Dist. Co., 3767 East 28th St.
 Division St.

Kalamazoo

Kala Coin Amusement Co. 826 Mills St.

Lansing

Music Systems, Inc., 812 Hamilton

Menominee

Empire Coin Machine Exc., 102-20th St.

Pontiac

Wolverine Entertainers, Inc., 1782 Pontiac
 Dr.

St. Ignace

Henry Nelson, St. Ignace, Mich.

MINNESOTA

Duluth

Twin Ports Sales Co., 226 Lake Ave., So

Faribault

Gopher Sales Co., 601-603 Central Ave.

PIN GAMES by



from IRVING MORRIS, INC.

EXCLUSIVE GOTTLIEB DISTRIBUTOR

Our Coin Machine Volume Is Based On Value
 and we do an international business!

CALL BI 3-4300 FOR PROMPT SERVICE

145 FRELINGHUYSEN AVE., NEWARK, NEW JERSEY 07114

CLEARING THE DECKS

For Delivery of New Equipment From Factories!

GRAND PRIX II ROCK-OLA PRINCESS ROYAL
 STARLET
 PHONOGRAPHS

GRAND PRIX I, Model 425 \$975
 418-SA 775
 414-SA 695
 404 625

Perfect Condition—Like Brand New!

1475 \$325 1496 \$375
 1458 225 1468 245
 1454 150 1478 295
 1475 325 1465 250

CHICAGO COIN SUPER-SONIC

SEEBURG KD200 \$250

BOWLERS CHICOIN	5 BALLS BALLY
TOURNAMENT \$895	BULL FIGHT \$350
MAJESTIC 895	BUS STOP 395
CADILLAC 695	BONGO 325
SPARE-LITE 695	MAD WORLD 325
GRAND PRIZE 650	HARVEST 295
ROYAL CROWN 495	SKY DIVER 250
GOLD CROWN 445	
CONTINENTAL 425	

CALDERON DISTRIBUTING, INC.

433 N. Alabama St. Phone: MEIrose 4-8468 Indianapolis, Indiana

U. S. Distributors and Jobbers LISTED BY STATES

Minneapolis
Atlas Sales Co. Inc., 720 S. 4th St.
Brown Brothers, 7600 Wayzata Blvd.
Lieberman Music Co., 257 Plymouth Ave. N.
S. L. London Music Co. Inc., 2605 Hennepin
Sandler Dist. Co., 236 Girard Ave. North
Gerald Sheafor, 4500 Oak Drive

St. Paul
Automatic Games Supply Co., 1934 Uni-
versity Ave.
K. C. Sales and Service, 1926 University Ave.
Mayflower Dist. Co., 2227 University Ave.
Midway Novelty Sales Co., 777 University
Ave.
Paster Dist. Co., 2227 University Ave.

MISSISSIPPI

Biloxi
United Novelty Co. Inc., Box 126

Greenwood
LeFloie Music Co., 712 George St.

Jackson
Capitol Music Co., 135 E. Amite St.
United Dixie Co. Inc., 106 Minerva St.

MISSOURI

Joplin
Sutherland Dist. Co. of Joplin, 501 Wall St.

Kansas City
Advance Music Co., 1606 Grand Ave.
Automatic Coin Machine Co., 13 W. Linwood
B&G Amusement Co., 3113 Gillham Rd.
Mid-West Dist., 709 Linwood Blvd.
Sutherland Dist. Co. Inc., 2710 McGee Traffic-
way
Uni-Con Dist. Co., 3410 Main St.
W. B. Music Inc., 2900 Main St.

Lemay
NBC Distributing Co., 780 Lemay Jerry Rd.

St. Louis
Advance Distributing Co., 4710 Delmar Blvd.
Arrow Nov. Co. Inc., 2852 Sidney St.
Brandt Dist. Co. Inc., 1809-11 Olive St.
Central Dist. Inc., 2315 Olive St.
Geo. Glass Dist. Corp., 1901 Delmar Blvd.
Ideal Novelty Co., 2823 Locust St.
L & R Dist. Inc., 1901 Delmar
McCall Novelty Co., 2315 Olive St.
Midwest Dist. Co., 1917 Delmar
J. S. Morris & Sons Novelty Co., 4722 Del-
mar
Morris Novelty Co., 3007 Olive St.
Musical Sales Co. Inc., 2920-2922 Locust St.
Reel Dist. Co., 4910 National Bridge
Rite-Way Distrib., 1916 Washington Ave.
J. Rosenfield Co., 4701 Washington Blvd.
W. B. Dists. Inc., 18 La Due Ridge Rd.

IDAHO

Pocatello
Dan The Music Man, 1229 N. Main St.

ILLINOIS

Chicago
Atlas Music Co., 2122 N. Western Ave.
Champion Dist. Co., 3451 N. Milwaukee
Empire Coin Machine Co., 1012 Milwaukee
Ave. North
Globe Dist. Co., 2330 N. Western Ave.
King & Co., 2700 Lake St.
Merit Industries, 7312 So. Halstead St.
National Coin Machine Exch., 1411-13
Diversey Boulevard
Purveyor Shuffleboard Co., 4322 N. Western
Ave.
Seeburg International, 1500 N. Dayton St.
Trans-World Trading Corp., 6445 North
Central Ave.
Western Trails Amuse. Co., 3249 No. Broad-
way
World Wide Dist., 2732 West Fullerton Ave.

Moline
Hallgren Dist. Co., 1626 3rd Ave.

Peoria
American Shuffleboard Sales Co., 101 S.
Goodwin St.

Rockford
Midwest Dist. Co., 208 N. Madison St.

INDIANA

Evansville
Automatic Amusement Co., 1000 Pennsylv-
ania St.
Carl J. Speis Co., P.O. Box 3133
S. L. Stiebel Co., 12-16 N.W. 6th St.
S & S Dist. Co., 1000 Pennsylvania St.

Fort Wayne
Antoine & Bechtel, 2101 Weisser Park
General Sales Co., 1416 S. Calhoun St.
Lee Sales Co., Inc., 1815 S. Lafayette

Indianapolis
Associated Dist. Inc., 210 S. Meridian St.
Calderon Dist. Inc., 423 N. Alabama St.
Fountain Sq. Music, 1117 Prospect
Lew Jones Dist. Co., Inc., 1301 North
Capital Ave.
J. & J. Dist. Inc., 1661 W. 16th St.
Sicking Co., 1312 N. Capitol Ave.
Siler Sales Co., 5955 Cooper Rd.
Southern Automatic Music Co. of Indiana,
Box 422

IOWA

Ankeny
Lamberti Music Co., 605 Walnut St.

Des Moines
Philip Moss & Co., 1420 Louost St.
Superior Sales Co., 1337 2nd Ave.

Dubuque
Dubuque Coin Machine Co., 1456 O'Hagen
St.

KANSAS

Manhattan
Bird Music Co., Inc., Box 290

Wichita
Sutherland Dist. Co. of Wichita, 1135
Washington St.
United Dist. Inc., 902 W. Second St.

KENTUCKY

Covington
Lew Jones Dist. Co. Inc., 329 W. 9th St.

Lexington
Southern Automatic Music Co. Inc., Henry
Clay Station, Box 7099

Louisville
B. B. Novelty Co. Inc., 715 W. Main St.
H. M. Branson Dist. Co., P.O. Box 4005,
814 E. B'way
Co-operative Dist. Co., 221 E. Market St.
Southern Automatic Music Co., P.O. Box 834
S. L. Stiebel Co. Inc., 635 W. Main St.

LOUISIANA

New Orleans
A. M. Amusement Co., 1025 Baronne St.
A.M.A. Dist. Inc., 1711 St. Charles Ave.
C. & M. Specialty Co., 832 Camp St.
Coin Mart, 1055 Baronne St.
Crown Novelty Co. Inc., 1055 Baronne St.
The Double A Amuse. Co., 341 N. Galvez St.
F. A. B. Dist. Co., 1019 Baronne St.
General Dist. Co., 1609 Orleans Ave.
J. H. Lynch Co. Inc., 1601 So. Gayoso St.
Operators Sales, Inc., 4122 Washington Ave.
New Orleans Novelty Co., 1055 Dryades St.
J. H. Peres Dist. Co., 922 Poydras St.
Space Dist. Co. Inc., 712 Clairborne Dr.
The Wurlitzer Co. 832 Baronne St.

Shreveport
S & H Novelty Co., 1550 Bolinger Ave.

MARYLAND

Baltimore
A. & A. Coin Machine Co., 715 Ensor St.
Eastern Dist., 1812 Worcester St.
General Vending Sales Corp., 239-245 W.
Biddle St.
Mar-Matic Sales Co., 1140 E. Coldspring
Lane
State Sales & Ser. Corp., 1825 Guilford Ave.

MASSACHUSETTS

Boston
Atlas Dist. Co., 1022 Commonwealth Ave.
Intl. Vending Corp., 1028-A Commonwealth
Ave.
Music & Vending Corp., 86 Brookline Ave.
Strauss Vending Machine Co., 1672 Wash-
ington St.
Trimount Automatic Sales Co., 40 Waltham
St.
The Wurlitzer Co., 78 Brookline Ave.

Brighton
Redd Dist. Co. Inc., 126 Lincoln St.
U. S. Dist. Co., 126 Lincoln St.
W. S. Dist. Inc., 126 Lincoln

Brookline
Ben D. Palastrant, 132 Beaconsfield Rd.

Watertown
Redd Dist. Co., 80 Coolidge Hill Rd.

NEBRASKA

Omaha
Central Dist., 1209 Douglas St.
Coin-A-Matic Inc., 201 S. 13th St.
H. Z. Vending & Sales Co., 1201-1207
Douglas St.
Lieberman Music Co. P.O. Box 3242
Phillip Moss & Co., 309 North 16 St.
United Products, 201 So. 13th St.

NEW HAMPSHIRE

Manchester
Tri-State Amusement Co., Bedford St.

NEW JERSEY

Belleville
113 Heckel Street

Elizabeth
Atlantic N.J. Corp. 730 Division St.
Seacoast Dists. Inc., 1200 North Ave.

Newark
Atlantic New Jersey Corp., 772 High St.
Irving Morris, Inc., 145 Frelinghuysen Ave.
R & Y, 604 Broadway

No. Bergen
Betson Enterprises, 3726 Tonnelle Ave.
Eastern Novelty Distributors, 3726 Tonnelle
Ave.

Springfield
Runyon Sales Company, U.S. Route 22 &
Fadam Road

Union City
American Shuffleboard Co. Inc., 210 Patter-
son Plank Rd.

MONTANA

Billings
Direct Sales Co., 2513 Montana Ave.

Butte
H. B. Brinck, 825 E. Front St.

Havre
Pete L. Weyh Co., P.O. Box 927

Helena
Capitol Music Co., 222 E. Lynsdale

Missoula
Greg's Vending, 456 Strand

NORTH CAROLINA

Charlotte
Brady Dist. Co., 1900 W. Moorehead St.
LeSturgeon Dist. Co. Inc., 2828 South Blvd.
P.O. Box 641
Roanoke Vending, Franklin 7-1310
The Seeburg Dist. Co., 801 S. Cedar St.
Southeastern Vending Distributing, Inc., 801
S. Cedar St.

Greensboro
National Products Corp., 2416½ High Point
Rd.

Raleigh
Bishop Music Co., P.O. Box 2168
Pierce Music Co., 415 East Martin
South Eastern Vending Dist. Inc., 1010 S.
Saunders St.

Reidsville
Trent Bros. Music Co., 708 N. Scales St.

NORTH DAKOTA

Bismarck
Dakota Music Corp., 912 Arthur Dr.

OHIO

Byesville
Vernon Yontz Sales Co., 140 Second St.

Canton
Stark Novelty Co., 239-30th St., N.W.

Cincinnati
Bigner Music, Inc., 2345 Quebec Rd.
Royal Dist. Inc., 1210 Glendale-Milford Rd.
Shaffer Music Co., 1889 Central Parkway

Cleveland
Cleveland Coin Machine Exch., 2029 Prospect
Ave.
Lake City Amusement Co., 4531-4533
Payne Ave.
Monroe Coin Machine Exchange, 2423 Payne
Ave.
Shaffer Music Co., 2126 E. 21st St.

Columbus
Central Ohio Coin Machine Exch., 315 E.
Fifth Ave.
Royal Dist. Inc., 1112 North High St.
See Vending Inc., 457 Neilstone St.
Shaffer Music Co., 849 N. High St.
University C. M. Exch., 858 N. High St.

Medina
Reinhardt Co., 734 E. Smith Rd.

Toledo
Toledo Coin Machine Exch., 814 Summit St.

Youngstown
J. & M. Novelty Co., 5555 Mahoning Ave.

OKLAHOMA

Oklahoma City
Atkins Music Co., 233 S. W. 20th St.
Automatic Music Dist., 900 N. Western Ave.
Boyle Amusement Co., 522 N.W. Third St.
Culp Dist. Co., 614-16 W. Sheridan Ave.
Dickson Dist. Co., 631 W. California Ave.
Rice Music Co., 611 N. Hudson
Sutherland Distrib. Co., Northwest Fourth
& Lee Sts.
Sutherland Dist. Co., 709 N.W. 4th St.

**There's a NEW kind of record
with a NEW kind of sound**

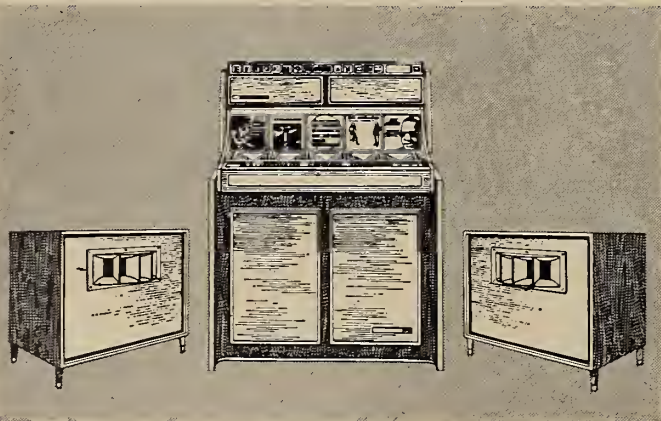

**...it's a NEW form of public
ENTERTAINMENT!**

**And it belongs to you . . . alone, compliments
of your Seeburg Distributor. The ONLY pho-
nograph showcasing these profitable sounds
is the SEEBURG LPC-480.**

To hear the sounds (and the facts)
just come in and see us, today.

SUTHERLAND DISTRIBUTING CO., INC.

2710 McGee Trafficway, Kansas City, Missouri HA 1-7446
Northwest Fourth & Lee Sts., Oklahoma City, Oklahoma CE 6-3691
226 South Flores St., San Antonio, Texas CA 6-0305
501 Wall Street, Joplin, Missouri
1135 N. Washington St., Wichita, Kansas 1343 S. Staples, Corpus Christi, Texas
3902 Pershing, El Paso, Texas

**DISTRIBS AND
JOBBER
LISTED BY STATES**

Tulsa
Automatic Music Co., 739 W. S. St.
H. W. Dolph Dist. Co., 2239 E. 6th St.
Tulsa Automatic Music Co., 739 West 5th St.

OREGON

Portland
Dunis Dist. Co., 1003 S.W. Front Ave.
Michael Dist. Co., 1200 S.E. Morrison
Northwest Sales Co. of Oregon, 1040 S.W.
2nd Ave.
Western Dist., 1226 S.W. 16 Ave.

PENNSYLVANIA

Erie
Mickey Anderson, 314 E. 11th St.

Harrisburg
D & L Coin Mach. Co., 414 Kelker St.

Moosic
Sterling Service, Rocky Glen Park

Philadelphia
Active Amusement Machine Co., 666 N.
Broad St.
American Shuffleboard Sales Co., 1511-13
Spring Garden Ave.
Banner Specialty Co., 1641 N. Broad St.
Block Marble Co., 2929 W. Cheltenham Ave.
Central Vend. Mach. Ser. Co., 6011 Balti-
more
Eastern Music Systems Corp., 334 N. Broad
St.
General Coin Machine Co., 929 Spring Gar-
den St.
International Amusement Co., 3810 Dor-
chester Rd.
Lehigh Specialty Co., 826 N. Broad St.
Model Vending 4830 No. Front St.
Rake Coin Machine Exch., 609 Spring Gar-
den St.
David Rosen, Inc., 2451 N. 56 St.
Scott-Crosse Co., 1732-42 Fairmont Ave.
S & K Dist. Co., 3608 Powelton Ave.
Steppin' Sam Co., 1439 Higbee St.
Veeco Sales Co., 2125 Market St.

Pittsburgh
Atlas Music Co., 2231 Fifth Ave.
Banner Specialty Co., 1508 Fifth Ave.
B. D. Lazar Co., 1635 Fifth Ave.
Music Dist. Co., 1945 Fifth Ave.
Oak Sales Co., 2033 Fifth Ave.
Pittsburgh Coin Machine Exch., 2203 Fifth
Ave.

Reading
Klopp Novelty Co., 312 No. 9th St.

Scranton
Active Amuse. Machines Co., 1101 Pittston
Ave.

Wilkes-Barre
Roth Novelty Co., 54 N. Pennsylvania Ave.

Williamsport
Williamsport Electronics and Television Co.,
233-35 W. Third St.

York
Crosse Dunham Co., 350 Greendale Rd.

SOUTH CAROLINA

Columbia
Friedman Amuse. Co. Inc., 2009 Main St.
G. K. Gabrielson & Co., 2608 Main St.
Peach State Music Co., 729 Lady St.
So. Eastern Vend. Dist. Corp., 1506 Taylor
St.
Sparks Specialty Co., 1820 Sumter St.

SOUTH DAKOTA

Pierre
Gordon Stout, Co., Box 4

TENNESSEE

Chattanooga
Chattanooga C. M. Co., 1820 Rossville Ave.
Dixie Amusement Co., 912 Houston St.
Sadikoff Sales Co., 142 No. Market St.
Shearer Amusement Co., 11 West Peak

Knoxville
Central C.M. Exchange, 2422 North Central
Roanoke Vend. Exch. Inc., 313 W. Depot
Ave. N.W.

Memphis
Consolidated Amuse. Co., 1269 Madison Ave.
Game Sales Co. Inc., 262 South Camilla
S. & M. Sales Co. Inc., 1074 Union Ave.
Sammons-Pennington Co., 1049 Union Ave.
Southern Amusement Dist., 628 Madison Ave.
Standard Aut. Dist. Co. Inc., 1269 Madison
Ave.
Williams Dist. Co., 1117 Union Ave.

Nashville
H. & N. Dist. Co., 313 Seventh Ave. So.
Hermitage Music Co., 469 Chestnut
Parker Dist. Co., Box 1281
Rock City Dist. Co. Inc., 615 Murfreesboro
Rd.

**Midway Intro's
'Mystery Score'
Skill Amusement**



**MIDWAY'S
'MYSTERY SCORE'**

CHICAGO—Marcine Wolverton and Hank Ross, heads of Midway Manufacturing Company, in Franklin Park, Illinois, last week announced the re-release to the coin machine trade of the new "Mystery Score" pitch and bat skill amusement novelty game which is already in full production in the Midway factory.

This game reportedly offers the operators, location owners, and players a surprising innovation in three-dimensional "fly away," skill targets, and three-dimensional playfield targets. The foremost scoring feature is the thrilling "Mystery Score" play feature which is practically guaranteed to keep skillful players dropping coins into the chute to keep trying to better the score. In this innovation several targets when hit on the playfield score a new mystery scoring feature.

Furthermore, Hank Ross explained there is an unlimited "last ball" play again feature in the new "Mystery Score" novelty amusement game. It is available in replay, regular, and extra ball models. It is also available with single or twin coin rejectors.

The beautifully appointed amusement game cabinet is 25 inches wide, 66 inches in height, and 55 inches in depth, suitably designed to easily fit in any size location—from the largest to the smallest.

Ross advised, in conclusion, that "Mystery Score" models are currently in full production in the factory, and sample shipments have already been rushed out to Midway Mfg. Co.'s family of distributors throughout the United States.

Sammons-Pennington-Nashville, Inc., 214
Sixth Ave South
Sanders Dist. Co., 612 8th Ave. So.
T. W. Amusement Co., 3104 Clarksville
H'way
Ten-Tucky Ser. Inc., 313 7th Ave. So.
Triangle Music Co., 206 W. Magnolia

TEXAS

Corpus Christi
Southland Dist. Co., 1343 Staples

Dallas
Southland Dist. Co., 1405 Turtle Creek Blvd.
Commercial Music Co., 1550 Edison St.
O'Connor Co. Inc., 9030 Directors Row
Southern Vending Co., 1405 Turtle Creek
Blvd.
State Music Co., 3100 Main St.
Walbox Sales Co., 3909 Main St.

El Paso
Sotherland Dist. Co., 3902 Pershing

Forth Worth
Forth Worth Amusement Co., 309 Ellison
Bldg. 103 Main St.
Sun Refinishing Co., 201 E. Daggett

Contact The Greatest . . . **THE GRECO BROS.**

★ For ALL Of Your ★
Domestic and Export Needs

Any Machine That Operates
With A Coin — We Got.
If We Don't — We'll Get It!

GRECO BROS. AMUSEMENT CO.

MAIN STEET, GLASCO, N.Y.
CHerry 6-8700

1288 BROADWAY, ALBANY, N.Y.
HO 5-0228

Congratulations to Cash Box
on its help to all in our industry
COIN-OPERATED INDUSTRIES OF NEBRASKA

(Formerly Music Guild of Nebraska)
1208 FARNAM STREET OMAHA, NEBRASKA

NEW YORK JOBBERS AND DISTRIBUTORS

Albany
Bilotta Enterprises, Inc., 1226 Broadway
Davis Dist. Co., 1056 Broadway
Greco Bros. Amuse. Co. Inc., 1288 B'way.
Universal Vendors, 788 Broadway

Binghamton
Binghamton Amusement Co. Inc., 221 Main
St.

Brooklyn
American Vending Co., 2684 Coney Island
Ave.
Herman Dist. Co. Inc., 1505 Coney Island
Ave.
Musical Distributors Corporation, 1640 Bed-
ford Ave.

Buffalo
B & B Distributors, 777 Main St.
Clare Enterprises, Inc., 5939 Main St.
Davis Dist. Corp., 1231 Main St.
Sheldon Sales, Dist. Corp., 881 Main St.
N. J. Steinke Co., 731 Main St.

Elmira
Joy Automatic, 108 E. Church St.

Glasco
Greco Bros., Main St., Box G.

Glen Falls
Witham Enterprises & Asso., 20 Cunning-
ham Ave.

Great Neck
L.I. National Sales, 243 N. Blvd.

Hudson Falls
Henry C. Knoblauch & Sons, 7 Broad St.

Newark
Bilotta Enterprises, 224 N. Main St.

New York
Atlantic New York Corp., 843 Tenth Ave.
R. H. Belam Co., 23 East 26 St.
Crescent Amusement Devices, 841 10th Ave.
Lipsky Dist. Corp., 607 Tenth Ave.
Dave Lowy & Co., 602 Tenth Ave.
Mike Munves Corp., 577 Tenth Ave.
Mondial Comm. Corp., 330 5th Ave.
Musical Distributors Corp., 841 Tenth Ave.
Runyon Sales Co., 593 Tenth Ave.
Seaboard New York Corp., 843-849 Tenth
Ave.
Albert Simon, Inc., 587 Tenth Ave.
United East Coast Corp., 583 10th Ave.
West Side Dist. Corp., 612 Tenth Ave.
Wiener Sales Corp., 559 Tenth Ave.

Rochester
Davis Dist. Corp., 319 Alexander St.
Flower City Dist. Inc., 389 Webster Ave.

Syracuse
Davis Corp., 738 Erie Blvd., E.
E. M. House Sales, 307 Meadow Rd.
Rex-Bilotta Dist. Co., 501 West Fayette St.

Utica
Victor Conte, 1001 Lansing St.

**JOBBER LISTS
BEGIN ON
PAGE 57**

UTAH

Salt Lake City
Dan Stewart Co., 140 E. Second South Ave.
Don Stewart Co., 140 E. 2nd St. So.
Interstate Dist., 917 So. State St.
Mel-O-Dee Music, Inc., 712 S. State St.
R. F. Jones Co., 375 So. 2nd West
Struve Dist. Co. Inc., 963 Folsom Ave.
Thompson Dist. Co., 127 E. Second South

VIRGINIA

Bayside
Old Dominion Vend. Cer., 1925 Terrace Ave.

Bristol
Roanoke Vend. Exch. Inc., 63 Common-
wealth Ave.

Norfolk
Diamond Coin Machine Exch. Inc., 609
Woodis Ave.
O'Connor Dist Inc., 1611 Virginia Beach
Blvd.
Southeastern Dist. Inc., 601 Woodis Ave.
(P.O. Box 87)

Portsmouth
O'Connor Vending Machine Co., 624 Craw-
ford St.
J. A. Woodard Co., 13 Oakcrest St.

Houston
American Shuffleboard Sales Co., 254 W.
Gray
Amusement Distributors, Inc., 1615 St.
Emanuel St.
Central Sales, 91 Dennis
H. A. Franz & Co., 606 Dennis
Gulf Coast Distributing Co., 6205 Gulf Free-
way, Houston, Texas
H & H Dist. Co., 3016 Polk St.
Southern Vending Company, 1 Main St.,
Room 376
Steele Dist. Co. Inc., 2617 Leeland
R. Warncke Co., 3445 Leeland Ave.
Bill Williams Distributing Co., 91 Dennis St.

Lubbock
Wallace Dist. Co., P.O. Box 75

Mineral Wells
Wallace Dist. Co., P.O. Box 75

Odessa
Sheffield Music Co., 1401 Maple St.

San Antonio
Sutherland Dist. Co., 226 So. Flores St.
Pan American Sales Co. Inc., 812 S. Presa
St
Santone Sales Co., 121 Navarro St.
R. Warncke Co., 121 Navarro St.
Bill Williams Dist. Co., 1415 So. Flores

U. S. Distributors and Jobbers

LISTED BY STATES

Richmond
Allen Dist. Co., 3409 West Leigh St.
O'Connor Vending Machine Co., 2318 W. Main St.
Roanoke Vend. Exch. Inc., 4930 W. Broad St.

WASHINGTON

Bellevue
M. J. Stanley Co., 309 112th St. NE.

Mercer
Michael J. Stanley Co., 7600 S.E. 24th Ave. POB 177

Seattle
American Shuf. Sales Co. of Seattle, 3144 Elliott Ave.
Bert Farmer, 1435 23rd Ave.
R. F. Jones Co., 309 9th Ave. North
Michael Dist. Co., 100 Elliott, W.
Music-Vend Dist. Co., 100 Elliott, West.
Northwest Sales Co., 3150 Elliott Ave. W.
Puget Sound Novelty Co., 114 Elliott Ave. W.
Western Dists., 3126 Elliott Ave.

Spokane
Western Dists. Inc., 1007 W. Wash. St.

Tacoma
Pacific Kiddie Ride Dist. Co., 1212 Tacoma Ave.
State Amusement Co., 1531 Broadway

WEST VIRGINIA

Charleston
Cruze Dist. Co. Inc., 1101 W. Washington St.
Roanoke Vending Ex. Inc., 625 Ohio Ave.

Fairmont
Mid-State Dist., 1909 Locust Ave.

Martinsburg
Hutzler Vend. Mach. Co., 1301 Winchester Ave.

Oak Hill
Allied Sales Co., 401 Jones Ave.

Wheeling
Allen Sales, Inc., 928-930 Market St.
Tri-State Amusement, 149 18th St., Rear
Wheeling Coin Machine Exch., 2829 Loff St.

WISCONSIN

Beloit
Dan Savage Nov. Co., 628 Third St.

Green Bay
Bookmeier Sales Co., 148 No. Chestnut St.
Feel Coin Mach. Exch., 245 Summit St.
Forst Dist. Co., 201 So. B'way
H & L Sales Co., 1337 Velp Ave.
Union Sales Co., 409 N. Adams St.

Lake Geneva
H & M Sales Co., Box 414

Milwaukee
Badger Novelty Co., 2546 N. 30 St.
General Novelty Co., 519 N. 16th St.
Hastings Dist. Co., 6100 W. Bluemound Rd.
Mitchell Novelty Co., 3506 W. National Ave.
Paper Dist. Co., 3601 W. Fond du lac.
Pioneer Sales & Service, 3110 W. Fond du lac Ave.
Summerfield Inc., 2736 W. Tutonia
S. L. London Music Co. Inc., 3130 W. Lisbon Ave.
United Inc., 1907 North 3rd St.

Sheboygan
Anthony Hirt, 2420 No. 8th St.

PUERTO RICO

San Juan
London Dist. Co., P.O. Box 8471
C. Hernandez
1816 Loiza St.
Santurce, P.R.

CANADA

Vancouver
Western Atom. Vending Ltd. 499 Commercial Dr.

St. John's, Newfoundland
Gus Winter Limited, Portugal Cove Road
Gilchrist Vending Ltd.
Edmonton, Alberta
Montreal, Quebec
Vancouver, B.C.
Toronto, Ontario
Winnipeg, Manitoba

Automat Formed In London

LONDON—Norman Miller, an expert in the field of visual juke boxes having introduced Scopitone to Great Britain some two years ago, has now announced the formation of his own company, Automat. Conscious of the market potential of visual juke boxes in this country Automat is committed to design, build and subsequently distribute a brand new model of quality but of a size suitable for the widest possible range of locations and at a price comparable to the standard type of juke box. At the moment the only visual boxes available in this country are imported. The manufacture of a new low-priced British model will not only result in a considerable reduction in price for the operator but will also avoid the additional customs duties. Once proved in this country Automat intend to develop and extend their activities by entering the export market.

In order to supply the very best and latest films for use in their machines Automat have, for some time, been carrying out extensive market research with the result that as soon as the boxes are available they will have an adequate supply of film to meet the most exacting demands.

Ditchburn 1st Yr. Report

LONDON—The Ditchburn Organisation celebrated their first full year as a public company by announcing a net profit for the year ended 31st March 1965 of £185,315 before tax (net profit for the year after tax £94,298—an increase of 21 per cent). The company proposed a final dividend on ordinary shares at 15 per cent less tax. The music division was again responsible for a large part of the Group profit with background music for the first time making a relatively small but valuable contribution. In spite of the obvious difficulties caused by the import surcharge the automatic phonograph section of the music division had a very successful year.

Sales and rentals of Wurlitzer equipment again exceeded 1000 units. Although the increased cost of the machines, due to import surcharges, have hindered the expansion prospects Ditchburn continue to sell and rent large quantities of Wurlitzer phonographs. Possibly the most encouraging feature of the year's results was, however, the progress of the United Kingdom vending division in terms of both income (which increased by over 40 per cent) and profit. The new 'break through' with the Ditchburn Teaspa and Wurlitzer cigarette machine have made important additions to the company's lines.

COIN MACHINE PARTS • SUPPLIES • REFINISHING • COIN COUNTERS

Abbott Coin Counter Co., Inc.
PO Box 1341
Greenwich, Conn.

Brandt Automatic Cashier Co.
515 First St.
Watertown, Wisc.

Block-Marble Co.
1425 N. Broad St.
Phila., Penna.

Coin Acceptors Inc.
4946 Daggett Ave.
St. Louis, Mo.

Coin Machine Improvement & Mfg. Co.
2365 Oldbridge Rd.
Dallas, Texas

D&R Industries
3323 Foster Ave.
Chicago, Illinois

Dynaball Industries
8039 Lawndale
Skokie, Illinois

Globe Dist. Co.
1623 N. California Ave.
Chicago, Ill.

Heath Sales Co.
570 Popular
Macon, Georgia

Inter-County Industries
809 Walnut St.
Reading, Pa.

Johnson Fare Box Co.
4619 N. Ravenswood
Chicago, Ill.

Lewis Mercantile Co.
40 Great Jones St.

Klopp Engineering Inc.
35551 Schoolcraft Rd.
Livonia, Mich.

Mar-Matic Sales Co.
1009 E. Baltimore St.
Baltimore, Md.

Marvel Mfg. Co.
2845 W. Fullerton Ave.
Chicago, Ill.

Mike Munves Corp.
577 Tenth Ave.
New York, N.Y.
National Rejectors Inc.
5100 San Francisco Ave.
St. Louis, Mo.

Peach State Dist. Co.
130 Blvd., N.E.
Atlanta, Ga.

Schmelke Mfg. Co.
Shakopee, Minn.

Sun-Glo Shuffleboard Supplies Inc.
115 Heckel St.
Belleville, New Jersey

Sun Refinishing Co.
201 East Daggett St.
Ft. Worth, Texas

Standard Changemakers Co.
422 E. New York St.
Indianapolis, Ind.

Vendronics Inc.
3961 Brotherton Rd.
Cincinnati, Ohio.

Wico Corp.
2901 N. Pulaski Rd.
Chicago, Ill.

Oct. Gaming Date Nears

LONDON—As mentioned in our A.T.E. issue dated 30 January 1965, the latest amendment to the Betting and Gaming laws comes into effect as at 31st Oct. 1965. This limits payments in kind to the value of 5/-(70 c).

Although not officially in operation until that date, many operators who have bought machines designed to comply with the law are already experiencing the results that will eventually be brought about.

Unfortunately the indications are that the new 5/- limit is having a depressing effect on takings. Penny play machines are not so badly affected as the odds are still much in favour of the player. But where to compensate for the declining value of money the stake has been up to 3d and 6d the incentive is so reduced that it is with these machines that player disinterest is most noticeable.

Although the issue of decimal coinage for Britain is still very much alive, no decision has yet been reached. The Socialist Government has indicated that in principle they are as keen to see it implemented as were their Conservative predecessors and have said that they will be coming to a decision as soon as possible. On the face of it there appears to be a strong possibility that we shall have it thrust upon us. In fact the thing most likely to defer a decision is the very congested parliamentary programme.

**ROANOKE Gives You Rowe AC FULL LINE
Diplomat, Celebrity & Customusic
In Va., W. Va, and N.C.**

ROANOKE Vending Exchange, Inc.

4930 West Broad Street

Richmond 26, Virginia (ATlantic 2-4221)

JACK G. BESS, Ch. of the Bd. • HARRY D. MOSELEY, Pres.

(Eldridge L. Fink) DICKENS 3-0311 (G. E. "Rusty" Derby) FRANKLIN 7-1310
Charleston, W. Va. Charlotte, N. C.

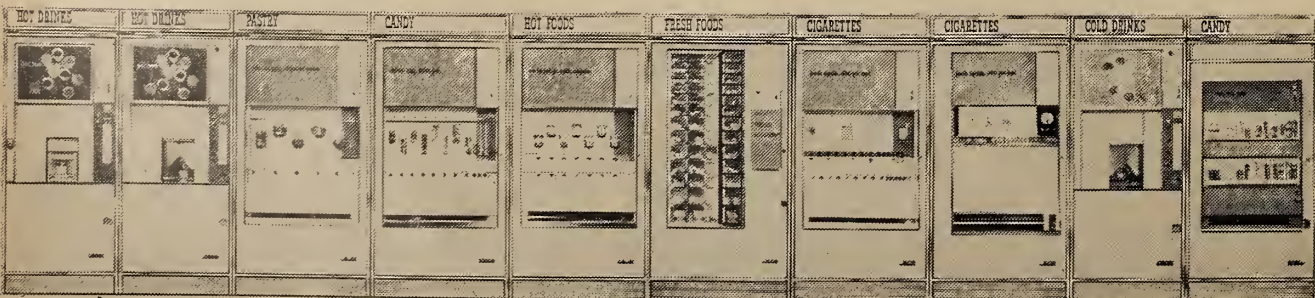

CIGARETTE MACHINE MANUFACTURERS AND CURRENT MODELS

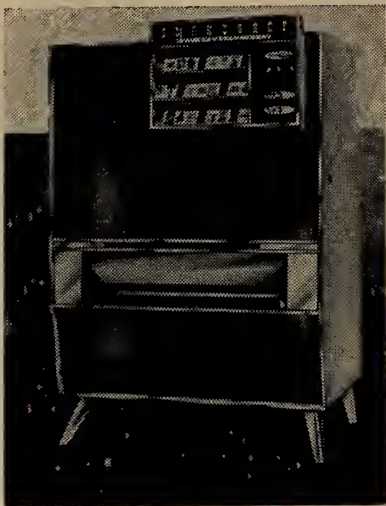

AUTOMATIC PRODUCTS
Smokeshop's Storlite Series Models 430, 450, 850 (capacities). With penny-nickel changer. Takes half-dollars.

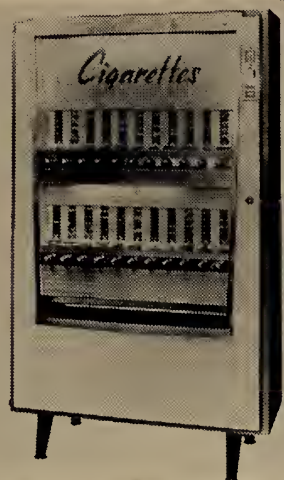

NATIONAL
Model 22M—22 selections; 850 capacity.



NATIONAL
Model 80M—850 capacity; 20 selection.

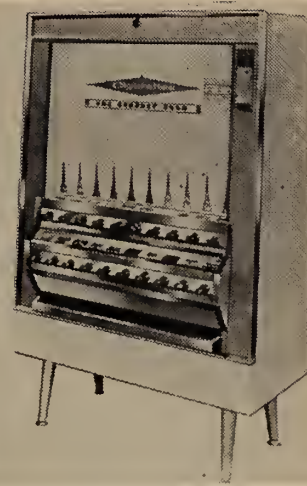

NATIONAL
Crown Series 800—20 cols. 10 front cols.; max. cop. 52; 10 rear max. cop. 33; total 850. Takes all sizes. Mechanical.

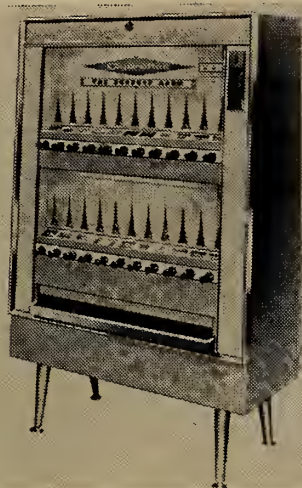

NATIONAL
Crown Series 222; 22 cols.; 11 upper cols.; max. cop. 33; 11 lower max. cop. 23; total 616. Takes all sizes. Mechanical.

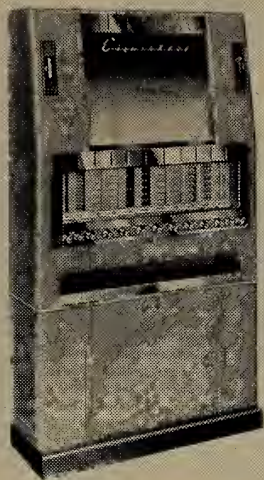

NATIONAL
Series 113; 13 columns, 9 flat, 4 split; All cols. take any size. Mechanical. 8 oux. shift cols.—443 capacity.



NATIONAL
Crowe 880; electric; top pack delivery; 22 selections; 880 pack capacity.



ROWE AC MFG.
Model 86; 510 pack capacity; 14 selections; manual coin mechanism.



ROWE AC MFG.
Riviera Model; 21 selections.



ROCK-OLA
Coravelle; electric; 800-pack cop.; vends all sizes; 20-sel.; tilt-out columns for service.

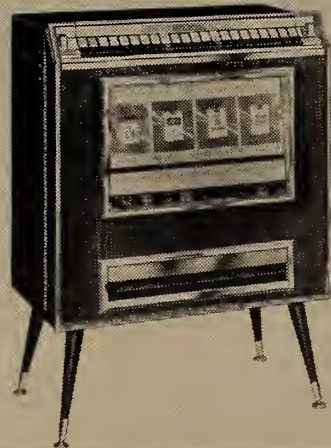

SEEBURG
Model 4E5; elec.; top-load; 11 cols. with 20-pack cop.; 11 cols. with 55 pack cop.; 825 capacity; 22 cols. all sizes; personalized.

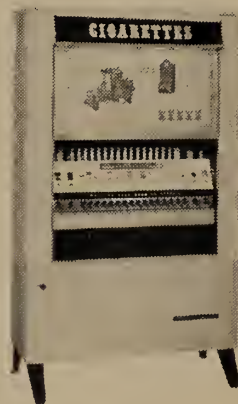

SEEBURG
Williamsburg Line
Models 14T1 and 14T1G; 4 cols. of 60 pack; 10 cols. of 27; 510 cop. Models W20T1 and W20T1G; 4 cols. of 60 pack; 16 cols. of 27; 672 cop.

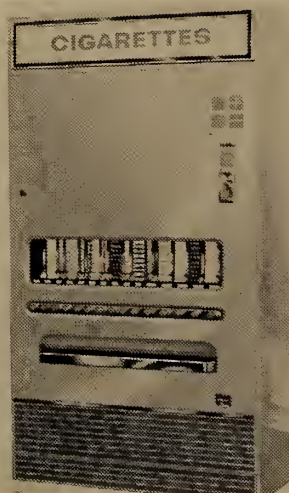

VENDO
Stoner Model C-23; 15-sel.; 520 cap.; reg or king-size.

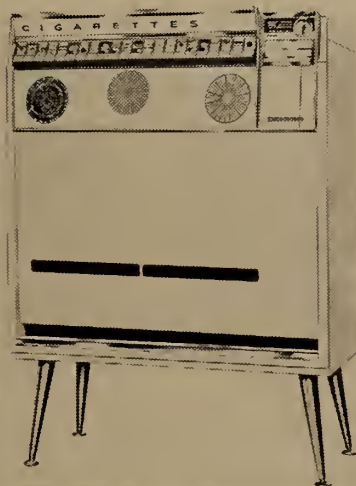

VENDO
Console model CA1A (also CA2A and CA3A) 22-sel.; 850 packs all sizes; electro-mechanical push-button; 11 single cols. swing out; 11 dual-shift in rear; first-in, first-out.

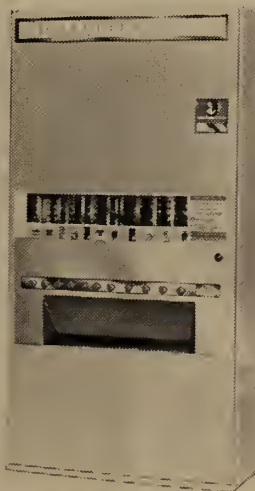

VENDO
428-special; 11-sel.; reg., king and lang-size packs; manual pull-knob; 5 shift cols. 58 packs; 3 reg. cols. 32 packs; 3 split 14 packs.

CANDY AND
SNACK
MACHINE
PICTURES
CONTINUE
ON PAGE 66





STUDIO B
BY A.21

by vending real "Espresso"



**money
at the
bottom
of each
cup?**

yes: money & money.... & money

coffee italian way, with

B_E 635

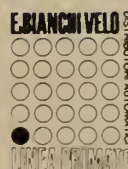

Linea Primato Automatic Vendor,
Manufactured by the famous Italian
Firm E. Bianchi Velo
also, in a Special Model for the American Market.



B_E 635

it's the
SENSATIONALLY
new way
of selling

B_E 635

the first
automatic vendor
which
grinds coffee
each time
for each cup,
to keep
the delicious
fragrance
and flavour
of the coffee grains

B_E 635

more
and more clients
and a safe
profitable business
for you



OUTSIDE BODY in bonderized steel plates soldered and strengthened; double glazing in synthetic oven baked enamel painting.

COFFEE MAKING PLANT constituted by a monoblock casting of bronze and brass actuated by chromium plated cylinders and pistons.

Hydraulic working (and hydraulic coffee dosage) minimizes management costs.

The coffee making plant performs the entire operative cycle of: coffee introduction, pressure, infusion, extraction, filter washing, coffee grounds removal.

The "espresso" coffee is prepared one cup at the time. The plant includes a boiler for overheated water, whose temperature is regulated by special control devices to guarantee complete safety and thermic stability.

The boiler is fed by means of a rotative pump connected with the reserve tank.

The grounds are removed and automatically set, dry, in an internal container.

DISTRIBUTION SERVICES. The coffee grains are introduced in a stainless-steel container; the coffee grinding is made cup by cup by a special automatic dosing grinder.

Sugar and milk are kept in transparent containers and their dosage is controlled by a special device.

The powder milk melts perfectly in a special mixing bowl, before distribution.

Chocolate is kept in a transparent container; melts and is whipped before distribution.

Cup station: in stainless steel for a perfect and easy cleaning and a comfortable keeping.

Water tank: allows the vendor to work even by low water pressure and during temporary interruptions in water distribution.

For sugared drinks a spoon is also automatically supplied.

DEPURATOR: an adequate depurator is recommended in order to avoid calcareous deposits. It can be supplied on request.

ELECTRIC PANEL: hermetic seal relés, on Octal and Undecal supports, to enable an immediate replacement when out of use.

SELECTION: by means of a push-button, after introduction of the coin. This post-selection system avoids the possibility of mistaking the choice.

On the buttons panel are three warning lights showing: 1. machine ready for selection; 2. machine working; 3. empty vendor.

CUP DISPENSER: type 9703 of ABT Products. Capacity: 635 cups; perfect hygiene. The cup dispenser wheels outwards and enables an easy and speedy filling.

AND REMEMBER: THE COFFEE, MILK, SUGAR, CHOCOLATE AND WATER DISTRIBUTORS CAN BE REGULATED TO GET JUST THE PERFECT DRINK TO MEET YOUR CLIENTS' PARTICULAR TASTES.

**E. BIANCHI VELO - LINEA PRIMATO
AUTOMATIC VENDORS DIV.**

**OFFICES: VIA FANTOLI, 11 - MILANO -
ITALY - PHONE 503441**

**FACTORIES: VIA ALESSANDRIA, 1-PON-
TECURONE (ALESSANDRIA)- ITALY -
PHONE 88076**

B_E 635

five selections
to satisfy all tastes:
sugared
or unsugared coffee
sugared or unsugared
"cappuccino"*
and hot chocolate

*"cappuccino" is the well known
milk and coffee italian way

B_E 635

*sell
the best
and get
the most:
the fabulous*

ESPRESSO

*coffee
italian way*

B_E 635

E. BIANCHI VELO

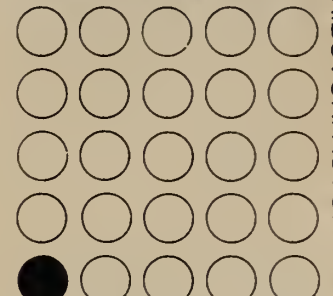

DISTRIBUTORI AUTOMATICI

LINEA PRIMATO



CANDY - SNACK MACHINES CURRENT MODELS

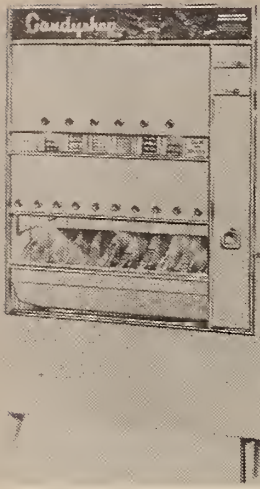

AUTOMATIC PRODUCTS

Candyshop Model; 10 candy columns with 400 bar capacity; 6 gum-mint columns with 200 capacity; first in/first out.



GOLD MEDAL

Model 105 peanut vendor; 250 sale capacity; stores 275 sales; 110 volt; National Rejector; electronic system.



GOLD MEDAL

Model 200 popcorn vendor; 120 10¢ sale capacity; 100 sale storage; electronic system; National Rejector; 110 volt.

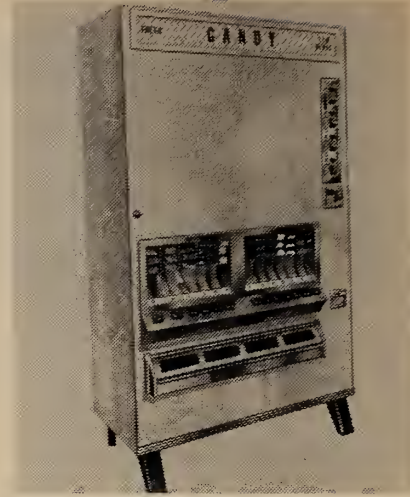

LEKTRO VEND

Model-002 large candy vendor; 21 selections, 2 stack units; 13 candy columns; 8 gum columns; 848 maximum capacity.

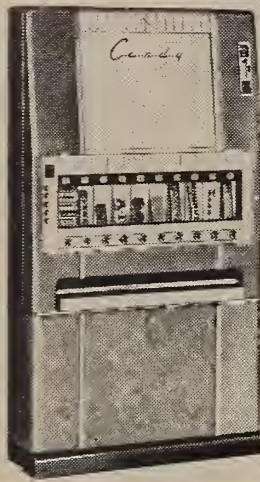

NATIONAL

Series 510 candy vendor; 14 selections; 9 bar columns; 5 gum; 416 units maximum; shelf reset lever; nickel tube and change maker.

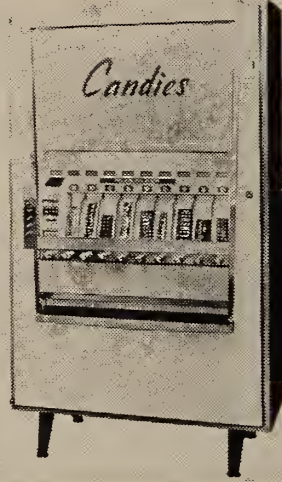

NATIONAL

Consoline candy vendor; 14 selections; 9 bar and 5 gum or mint; maximum 416 units; nickel chongemaker; variable shelving.

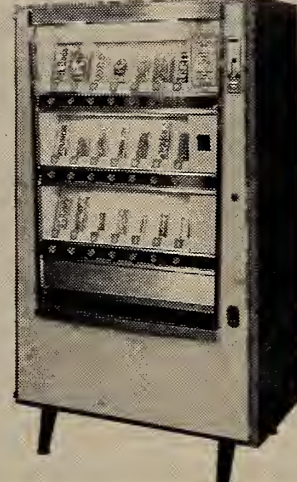

NATIONAL

Moduline candy vendor; 21 selections; 588 maximum units; first-in, first out; electrical merchandise feeding rocks; 10 swing out shelves.

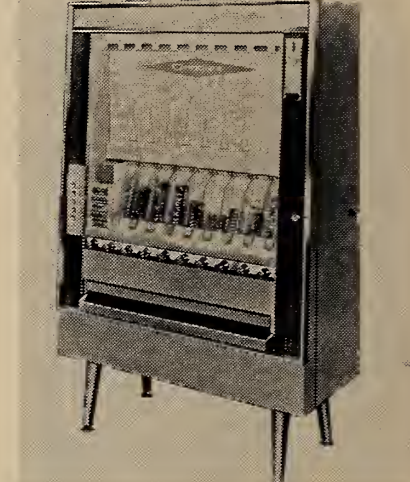

NATIONAL

Series CC Crown Line DeLuxe; 14 selections; Max. capacity 416 units; 9 bar plus 5 gum or mint; coin mechanism; set price selector; variable shelving.

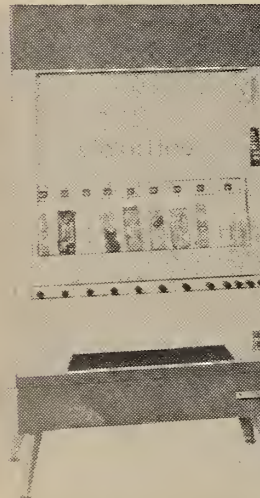

ROWE AC MFG.

Model 77; 11 columns; 340 item capacity; manual coin mechanism.

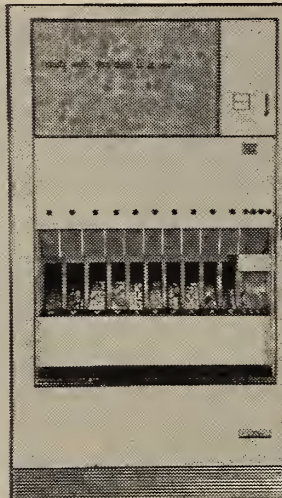

ROWE AC MFG.

Fifo Model; first in/first out delivery; 14 column capacity with candy and gum-mint.



SEEBURG

Williamsburg Line; models W10CN1-10C, W10CN1-5/10C, W10CN1G-10C and W10CN1G-5/10; 10 selections; 2 or 3 cols., adjustable; cap. 220.

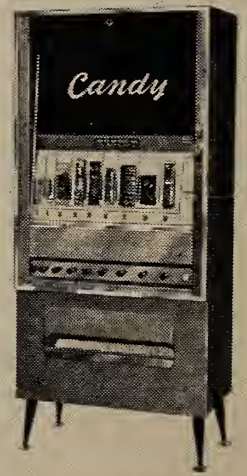

UNIVERSAL VENDORS

Candimot made by Westinghouse; 7 columns of 24 shelves & 2 for 100 5¢ gum or 68 10¢ gum-mint; maximum capacity 268 items; manual operation.

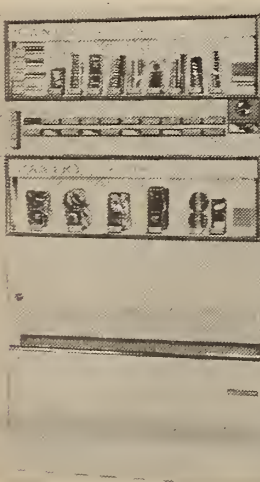

VENDO

Staner Model FA8A candy-postry, gum-mint unit; variable shelf sizes; 7 cols. 20 shelves; 2 cols. 24, 6" & 8" deep; 4 cols. 20; 4 cols. variable gum & mint.

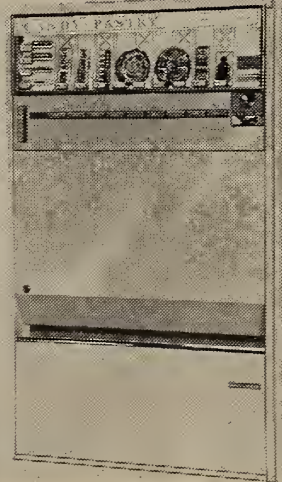

VENDO

Staner Model FA3A candy-postry with gum-mint unit; variable shelf sizes; 3 cols. 20 shelves; 2 cols. 24 shelves; 2 cols. 20 shelves; 4 cols. variable gum-mint.

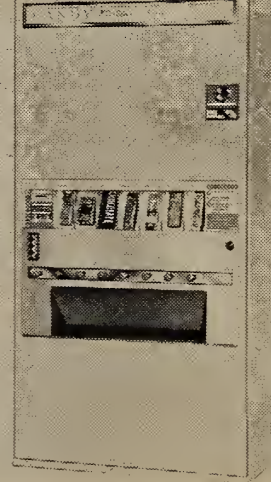

VENDO

Staner Model FA2A candy with gum-mint unit; variable shelf sizes; 7 cols. 20 shelves; 2 cols. 24 shelves; 4 cols. variable gum-mint.

VENDING MACHINE LISTINGS BEGIN ON PAGE 61.

CIGARETTE, CIGAR, HOT AND COLD DRINK MACHINES

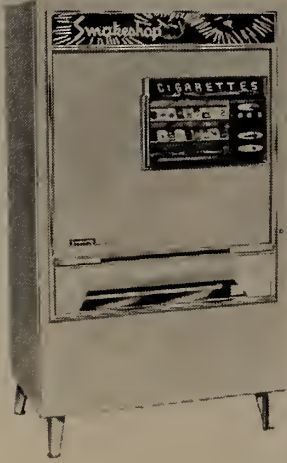

AUTOMATIC PRODUCTS
Smokeshop Modulator '900'

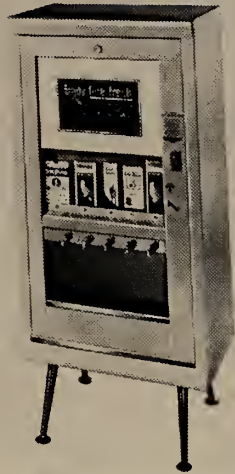

GENERAL CIGAR
5-col.; also available 7 cols.

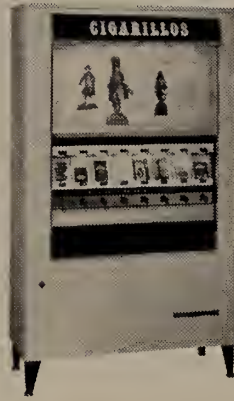

SEEBURG
Williamsburg line: cigarillos; Model W8C01; 8-sel.; 200 cop.



SEEBURG
Williamsburg line: cigar vendor Model W6CR1; 6-sel.; 114 cop.



DITCHBURN
Minicold Model
Cold Drink Unit



DITCHBURN
Minispa Model
Hot Drink Unit



ROWE AC MFG.
Model 1020
Cold Drink Unit

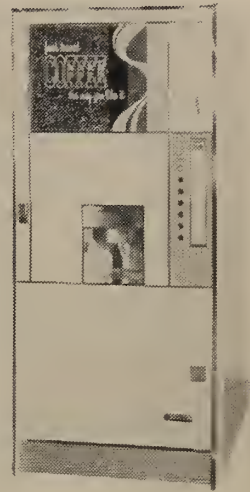

ROWE AC MFG.
Model SK-9
Coffee Machine

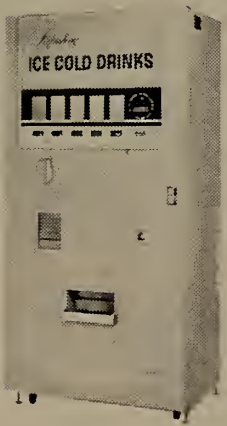

Rock-Ola MODEL 3302
Cold Drink Unit



Rock-Ola MODEL 3301
Cold Drink Unit



SERV-O-MATIC
Hot Coffee, chocolate,
soup vendor

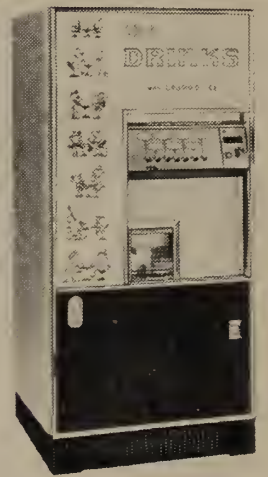

SEEBURG
Cold Drink Unit



SEEBURG
Hot Drink Unit



SEEBURG
Hot Drink Unit



SEEBURG
Cold Drink Unit

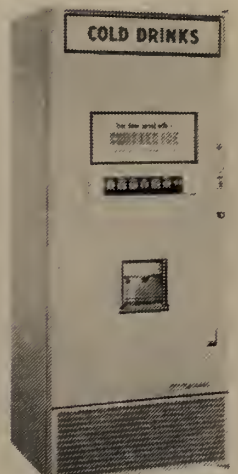

SEEBURG
Cold Drink Unit

VENDING MACHINE MFRS.—TYPE EQUIP. PRODUCED

THE ALASKAN CO., INC.
1140 Kirkland Ave
Nashville, Tenn.
Ice

ALCO COIN LOCK CO.
32a Harvard St.
Brookline, Mass. 02146
Toilet Locks

ALD, INC.
7045 North Western Avenue
Chicago, Illinois
Drycleaners, dryers, washers, extractors, coin changes, laundry supplies

PRISCILLA ALDEN COSMETICS, INC.
422 Main Ave
Clifton, New Jersey
Lipstick, perfume, comb, moist towelette

ALGAS INDUSTRIES
3951 South Capital Ave
City of Industry Calif. 95610
Candy bars, cigarettes, soft drinks

ALLEN ELECTRONICS, INC.
2260 Avenue A
Bethlehem, Pa. 18001
Coffee, instant packet, hot chocolate, soft drinks, pre-mix, soup (cup), tea

A.M.M. MANUFACTURING CORP.
1400 Rahway Ave
Avenue, N. J. 07001
Ice cream, milk

AMERICAN CLEANING EQUIPMENT CORP.
5024 Rose St.
Schiller Park, Ill. 60176
Vacuum cleaner for cars

AMERICAN COIN LOCK COMPANY, INC.
453 Cottage Street
Pawtucket, Rhode Island
Toilet locks

AMERICAN HYGIENIC CORPORATION
(Division of Delicate Corporation of America)
717 Pine St.
Camden, N.J.
Sanitary napkins

AMERICAN LOCKER COMPANY, INC.
Jones & Gifford Ave.
Jamestown, N.Y. 14701
Lockers for checking parcels

AMERICAN SCIENCE CENTER, INC.
5700 Northwest Highway
Chicago, Illinois 60646
Telescopes

AMERICAN UNIVEND CORPORATION
405 Lexington Ave
New York, New York 10017
Candyroll items, supplies.

AUTOMATIC PRODUCTS COMPANY
(Division of Gross-Given Manufacturing Company)
301 Chestnut Street
St. Paul, Minn. 55102
Cigarettes, component parts

AUTO-POP MFG. CO., INC.
14 North Ninth Street Building
St. Louis, Mo. 63101
Fresh popped corn

AVENCO (ADVANCE ENGINEERING COMPANY)
2412 University Avenue, S.E.
Minneapolis, Minn. 55414
Instant and fresh brew coffee, hot choc., canned food, tea, soup, coin changers, cold drinks

BEAUTY AID HAIR DRYERS
(Div. of Helene Curtis Ind., Inc.)
4401 West North Ave.
Chicago, Illinois 60639
Hair Dryers

BEL-CAL CORPORATION
602 South Bridge Street
Visalia, California 93277
Coin changers, paper currency changers, paper currency handling venders

BEST PLASTIC PRODUCTS INC.
(Subsidiary of Marlen Co.)
325 West 25 Pl.
Chicago, Ill. 60616

BOWL-O-MATIC
(Division of Automatic Bowl Manufacturing, Inc.)
235 Robbins Lane
Syosset, Long Island, New York
Coin operated bowling pinsetters

K. G. BROWN MFG. CO., INC.
Wickham Avenue
Mattituck, Long Island, New York 11952
Charcoal, ice, milk, ice cream, bait, groceries, hosiery, soup

CACO MFG. CORP.
5816 Heiser St.
Houston, Texas 77032
Hair dryers

CAVALIER CORPORATION
1100 East 11th Street
Chattanooga 3, Tennessee 37043
Drinks, canned & bottled

CHECKMATE BATTERY VENDING
4853 Joyce Drive
Dayton 39, Ohio
Batteries

CHEMSPRA INT'L CORP.
570 South Colorado Blvd.
Denver, Colorado 80222
Car wash equipment

CHOICE-VEND
(A Division of the Seeburg Corporation)
Turn Pike Rd.
Windsor Locks, Conn.
Bottled soft drinks, milk
Export Rep: Belanex Intl.
51 Madison Ave., N.Y.C.

COAN MANUFACTURING CO.
2070 Helena Street
Madison, Wisc. 53704
Candy, gum, cookies, crackers, cigarettes, instant coffee, hot chocolate, soup, pastry

COFFEE-MAT CORPORATION
107 Trumbull Street
Elizabeth, N.J. 07206
Single cup, fresh brew coffee, hot choc., soup tea

COIN ACCEPTORS, INC.
4946 Daggett St.
St. Louis, Mo. 63110
Currency and coin changers, components

COIN-TROLLED EQUIPMENT CORP.
11436 Hart Street
North Hollywood, California 91605
Newspapers & magazines

JOHN F. COLBERT CO.
612 Kahl Building
Davenport, Iowa 52801
Car wash equipment

COLMA, INC.
70 Piedmont Street
Worcester, Mass. 06110
Cologne spray, lotions, supplies products

COMMERCIAL MECHANISMS
218 Sandy Spring, Place N.E.
Atlanta, Ga. 30328
Soft drinks, plastic bottles, sanitary napkins, juice, milk

CONTINENTAL-APCO, INC.
(Now owned by The Vendo Co.)
(Subsidiary of Continental Vending Machine Corp.)
956 Brush Hollow Road
Westbury, Long Island, N. Y.
Cigarettes, post-mix soft drinks, post-mix soft drinks with ice, pre-mix soft drinks, pre-mix soft drinks with ice, batch fresh-brew and instant coffee, hot chocolate, soup, popcorn, ice cream, hot and cold prepared food, also supplies vendible products and vending machine components and supplies.

CONTINENTAL MANUFACTURING CO., INC.
Dewey Street
Conway, Pa. 15027
Exercise equipment

THE CORNELIUS COMPANY
2727 North Ferry Street
Anoka, Minn. 55303
Bottled soft drinks

COUNCIL MANUFACTURING COMPANY
420 North Second Street
Fort Smith, Ark.
Ice, charcoal, vending machine components & supplies

DELICATE CORP.
717 Pine St.
Camden, N. J. 08103
Sanitary napkins vending machine

DEMAY INC.
2641 Decatur Avenue
New York, N.Y. 10058
Single cup fresh brew, tea, hot choc., soup

DIAL-A-SHAKE INC.
Route 30 & Oak Ave
New Lenox, Illinois 60451
Milkshakes

DILLON MFG. CO.
3203 Grace Street, N.W.
Washington 7, D.C.
Postage stamps

DITCHBURN VENDING MACHINES, INC.
(Div. of The Ditchburn Org. Ltd., England)
1826 North Elston
Chicago, Ill. 60622
Instant coffee, cookies, crackers, hot choc, pastry, tea, soft drinks, laundry supplies

DIVIDENDS DISPENSER, INC.
1115 Main Street
Bridgeport, Connecticut 06603
Tickets

DOCUMAT, INC.
84 Fourth Avenue
Waltham, Mass. 02154
Photo copy machines

E. B. METAL PRODUCTS CO.
P. O. Box 149
Whitehall, New York 12887
Bags, bait, books, cookies, crackers, handkerchiefs, hosiery, food, insurance, laundry, pens & pencils, napkins

EASTERN SPECIALTY PRODUCTS, INC.
83 Zeigler Street
Boston, Massachusetts 02119
Milk, supplies

ELECTROWARE CORPORATION
5350 Rondeau St.
Toledo, Ohio 43615
Popcorn

EM-RO DISTRIBUTORS
6355 North Broadway
Chicago, Illinois 60626
Parking lot gates

ENVIRO EQUIPMENT CORPORATION
369 Linden Street
Brooklyn, N.Y. 11227
Ice

THE EXHIBIT SUPPLY COMPANY
4719-21 West Lake Street
Chicago, Ill. 60644
Post cards, coin-operated plastic laminating machines

FEDERAL DIV., THE VICTOREEN INSTRUMENT CO.
1055 Stewart Ave.
Garden City, N.Y. 11534
Photo copy machines

FERROMATIC PRODUCTS
(Division of Ferro Stamping Company)
1367 Franklin Street
Detroit, Mich. 48207
Canned soft drinks

FLATTO MANUFACTURING COMPANY
Cotton Exchange Bldg.
Brownsville, Texas 78520
Stamps, stamp folders

THE FLXIBLE COMPANY
326-332 North Water Street
Loudonville, Ohio 44842
Lockers

FOLLETT CORPORATION
99 Broad Street
Phillipsburg, New Jersey 08862
ice

FORD GUM AND MACHINE COMPANY, INC.
P.O. Box 192
Akron, N.Y. 14001
Ball gum, candy

FRUIT-O-MATIC MANUFACTURING COMPANY
P.O. Box 551
7855 Sepulveda Boulevard
Van Nuys, Calif. 01408
Refrigerated fresh fruit

GARDNER MANUFACTURING COMPANY
263 Kansas Street
Horicon, Wisc. 53032
Hot canned food, soup

GENERAL CIGAR CO., INC.
605 Third Ave.
New York, New York 10016
Cigars, supplies vendible products

GENERAL VENDING CORP.
(Subsidiary of Mr. Hot Cup, Inc.)
29 Terminal Way
Pittsburgh, Pa. 15219
Books, coffee, newspapers, magazines

GIEPEN ASSOCIATES, INC.
8538 West Grand Ave.
River Grove, Illinois 60171
Instant coffee, hot choc., soft drinks, soup, tea
Comic books

(Continued on page 69)

NRI Has Conveniently Located Sales and Service Headquarters Throughout the Country. Just Check the Listing Below for the Office Nearest You.

5100 San Francisco Avenue
St. Louis, Missouri 63115
COlfax 1-1900

42-71 65th Place
Woodside, L. I., New York 11377
NR 2-3200

2516 Waco Street
Richmond, Virginia 23229
ATlantic 8-7665

2119 South Flower Street
Los Angeles, California 90007
Richmond 9-6367

1209 Williams Street
Atlanta, Georgia 30309
TRinity 6-4318

4907 West Fullerton Avenue
Chicago, Illinois 60639
NAtional 2-3614

8801 Joy Road
Detroit, Michigan 48204
TExas 4-6295

4633 Insurance Lane
Dallas, Texas 75205
LAKeside 6-7983

3513 Bathurst Street
Toronto, Ontario, Canada
RUssell 1-5629

National Rejectors, Inc. G.m.b.H.
Buxtehude, Zum Fruchthof
Germany
23-46 or 24-49

National Rejectors (United Kingdom) Ltd.
Bentley House
225 Streatham High Rd.
London, S.W. 16, England
STreatham 3324 or 3325

Resident Engineers In Other Principal Cities

Manufacturing Facilities

5100 San Francisco Avenue
St. Louis, Missouri 63115
COlfax 1-1900

Highway 88
Hot Springs, Arkansas 71902
ROckwell 7-2313

National Rejectors, Inc. G.m.b.H.
Buxtehude, Zum Fruchthof
Germany
23-46 or 24-49



VENDING MACHINE MFRS.—TYPE EQUIP. PRODUCED

GLASCO CORPORATION
(Subsidiary of Universal Match Corporation)
Fifth and Perkins Streets
Muncie, Ind. 47305
Instant coffee, bottled & canned soft drinks,
pre-mix drinks

GLOEKLER REFRIGERATOR CO.
20th Street West of Powell Ave.,
Erie, Pennsylvania 16512
Pizza, component & supplies, french fries, hot
dogs, hamburgers

GOLD MEDAL PRODUCTS COMPANY
1825-39 Freeman Avenue
Cincinnati, Ohio 45214
Pre-popped popcorn, pre-packaged detergents
Hosiery, Peanuts

ANDREW GORRETTA & COMPANY
5209 Euclid Avenue
Cleveland, Ohio 44103
Cigarettes

GRISWOLD VENDING COMPANY
(Division of Northwest Automatic Products
Corporation)
1204 Chestnut Avenue
Minneapolis, Minn. 55403
Pre-brew coffee, bulk milk, packaged merchan-
dise

G.S.W. COIN-OP SUPPLY INC.
310 North Austin
Dallas, Texas 75202
Bags, laundry supplies, popcorn

HAIRDRI VALETING, INC.
725 Columbia Ave.
Belvidere, Ill. 61008
Hairdryers

HAMILTON SCALE COMPANY
3350 Secor Road
Toledo, Ohio 43606
Scales, coin changers, stamps, tickets

HARBY INDUSTRIES
14753 Arminta St.
Van Nuys, Calif.
General merchandise

THE HEINZ MANUFACTURING COMPANY
P.O. Box 524
Bristol, Conn. 06012
Bulk products, cartoned milk, bottled milk,
newspapers, magazines, fruit juice, groceries,
eggs, bottled & canned soft drinks

HILSON INDUSTRIES, INC.
5300 Vine Street
Cincinnati 17, Ohio 45217
Ice

HILSUM SALES CORPORATION
(Subsidiary of American Sumatra Tobacco
Corporation)
344 North East 61st Street
Miami, Fla. 33137
Stamps, cigars, cigarettes, newspapers, maga-
zines, post cards

HOSPITAL SPECIALTY CO.
(Div. of American Automatic Vending Corp.)
1991 East 66 St.
Cleveland, Ohio 44103
Sanitary napkins

HYPRESSURE JENNY
(Div. of Homestead Valve Mfg. Co.)
Box 348
Coraopolis, Pa. 15108
Car wash equipment

HYPRO ENGINEERING, INC.
700-39 Ave. N.E.
Minneapolis, Minn. 55421
Car wash equipment

ICE-LEASING CORP.
98-11 178 Place
Jamaica 33, N.Y.
Bagged ice

ICE PLANT EQUIPMENT CO., INC.
2543 Frankford Ave.
Phila., Pa. 19125
Bait, ice

**INTER-AMERICAN STAMP VENDING
CORP.**
45 Bergen St.
Brooklyn, N.Y. 11201
Cards, Postage stamps

**INTERNATIONAL BALLY COFFEE VEND-
ING CORP.**
(Div. of Seeburg Corporation)
6119 Howard Street
Niles, Illinois 60648
Fresh-brew coffee, hot choc., soup, tea

**INTERNATIONAL MUTOSCOPE CORPORA-
TION**
11-12 44th Ave.
Long Island City, New York 11101
Auto. photo, voice recordings, books, magazines,
laminating machines, handkerchiefs, sanitary
napkins, insurance

JENNINGS AND COMPANY
(Division of Hershey Manufacturing Com-
pany)
4309 West Lake Street
Chicago, Ill. 60624
Canned, cartoned, bottled milk, canned drinks,
groceries, specialty items, supplies

JOHNSON FARE BOX
(Subsidiary of Bowser, Inc.)
4619 Ravenswood Avenue
Chicago, Ill. 60640
Coin changers, components

**KWIK KAR WASH & KWIK KAR DRIVE-
THRU INC.**
147 Parkhouse
Dallas, Texas 75207
Car wash equipment

L & A PRODUCTS INC.
869 Hersey St.
St. Paul, Minn.
Car wash equipment

LA CROSSE COOLER CO.
2809 Losey Boulevard, South
La Crosse, Wisc. 54602
Bottled soft drinks

LEKTRO-VEND CORP.
P. O. Box 649
Sullivan Rd.
Aurora, Ill. 60507
Candy bars, cookies, crackers, gum, hosiery,
handkerchiefs, lipstick, lotion, pastry, per-
fume, potato chips, pretzels, general purpose
venders

LEONARD SALES CO.
(Subsidiary of Veeco Beauty Equipment Mfg.
Co.)
167 North Racine
Chicago, Illinois 60607
Hair dryers

EDW. LIVINGSTON & SONS, INC.
1735-39 Walnut St.
Kansas City, Mo. 64108
Car wash equipment



Coin Handling Equipment

**SPECIFIED
FROM COAST TO COAST**

by Professional Bottlers and Operators

Who Demand The Utmost in

Quality, Dependability and Service

NATIONAL REJECTORS, INC. • ST. LOUIS 15, MISSOURI *Offices in Principal Cities*
A Subsidiary of Universal Match Corporation



See the Universal Match Corporation Exhibit • Missouri Pavilion • New York World's Fair • 1964-65

(Continued on page 70)

VENDING MACHINE MFRS.—TYPE EQUIP. PRODUCED

(Continued from page 69)

MAGIC BAY CAR WASH SALES, INC.
305-12 Ave. So.
Nashville, Tenn. 37203
Car wash equipment

MALKIN-ILLION COMPANY
400 Coit Street
Irvington, N.J. 07111
Cigars

The sale (10c)



The profit (7 1/3c)



The profit maker!

Nationally, hundreds of locations are proving it every day: 7 1/3c profit per 10c sale with our popcorn vendor. And profits build with practically no effort on your part. Customer serves himself; maintenance is minimum; all you do is fill it with pre-popped and pre-flavored popcorn. Only needs 17 x 17" floor space. Takes a dime or two nickels; 15c operation optional. Handsome unit, too. Remember, everybody loves popcorn, and popcorn means more beverage sales. This vendor costs less than you think. Write for full information.

Similar model available for peanut vending

Exclusive Export Manager
G. C. Wilster
Gold Medal Products Co.
Box 3214 Stamford, Connecticut



1893 Freeman Ave., Cincinnati 14, Ohio

W. MANNHARDT & SON, INC.
7916 West Grand Avenue
Chicago 35, Ill.
Ice

THE MARTIN BROS. ELECTRIC CO.
3620 Perkins Ave.
Cleveland, Ohio 44114
Hair dryers

MARVEND, INC.
409 Clay St.
Marietta, Ga. 30062
Instant coffee, soup, tea, candy, potato chips, note book paper, pretzels

MAYVILLE METAL PRODUCTS COMPANY
First and Highland
Mayville, Wisc. 53050
Contract mfrs., also components

MECHANICAL SERVANTS, INC.
6610 North Clark Street
Chicago, Ill. 60626
Combs, sanitary napkins, lipstick, ball pens, toys, perfume, souvenirs, razors, razor blades, gum, pencils, hand lotion

METERFLO DISPENSERS, INC.
4201 West Peterson Ave
Chicago, Ill. 60646
Juices, bulk milk

MICRO-MAGNETIC INDUSTRIES INC.
951 Commercial St.
Palo Alto, California 93400
Money changing equipment, ticket venders

MILLER INDUSTRIES
(Division of Guardian Ind., Inc.)
180 East Sixth St.
Dubuque, Iowa
Hair dryers, vending machine components & supplies

MISTER MAGIC, INC.
(Div. of Self Service Equipment Co., Inc.)
2501 Hawn Freeway
Seagoville, Texas 75159
Car wash equipment, truck mobile, power wash equipment

JOHN E. MITCHELL COMPANY
3800 Commerce St.
Dallas, Texas 75221
Car wash cabinet

MODEL VENDING CONTROLS INC.
11711 Chillicothe Rd.
Chesterland, Ohio 44026
Money changing equipment

MODERN PRODUCTS COMPANY
Route 6
Box 365A
Yakema, Wash 98901
Refrigerated fresh fruit

MORTON LAMM & ASSOCIATES
1017 Oak Lane
Phila., Pa. 19126
Cigarettes, cookies, crackers, currency venders, hot & cold packaged food, groceries, bottled & cartoned milk, pretzels, bottled & canned drinks

NARCO
(Subsidiary of the Navarre Corporation)
Pioneer Bank Building, Suite 600
Chattanooga, Tennessee 37402
Bottled and pre-mix soft drink machines

NATIONAL REJECTORS, INC.
(Subsidiary of Universal Match Corporation)
5100 San Francisco Avenue
St. Louis, Mo. 63115
Currency changers, coin changers, cup venders, components

NATIONAL SANITARY LABORATORIES, INC.
6652 North Western Avenue
Chicago, Ill. 60645
Sanitary napkins, combs, razor blades, pens & pencils

NATIONAL VENDORS, INC.
(Subsidiary of Universal Match Corporation)
5055 Natural Bridge Avenue
St. Louis, Mo. 63115
Cigarettes, candy, gum, mints, cookies, crackers, pastry, refrigerated sandwiches, hot cans, genl. mchdse.

NEDACO, INC.
13747 So. Western Ave.
Blue Hills, Ill.
Carded merchandise, handkerchiefs hosiery

NEWSPAPER ENTERPRISE ASSOC.
(Div. of Scripps-Howard Newspapers)
1200 West Third St.
Cleveland, Ohio 44113
Newspapers & magazines

THE NIK-O-LOK CO., INC.
422 East New York Street
Indianapolis, Ind. 46202
Toilet locks

NORRIS DISPENSERS, INC.
2720 Lyndale Avenue, South
Minneapolis, Minn. 55408
Cartoned-bottled milk

THE NORTHWESTERN CORP.
East Armstrong Street
Morris, Ill. 60450
Bulk nuts, gum, candy, stamps

NU-PROCESS INDUSTRIES, INC.
13374 Farmington Rd.
Livonia, Mich. 48150
Car wash equipment

OAK MFG. CO., INC.
650 South Ave 21
Los Angeles, Calif. 90000
Bulk products, cards, gum, sanitary vendors

OMNIVEND METALAB EQUIPMENT CO.
270 Duffy Ave
Hicksville, N.Y. 11801
Bottled & canned milk, soft drinks

NATIONAL SALES OFFICES MARKETERS, INC.
41 E. 42 St.
New York, N.Y. 10017

PACIFIC NIK-O-LOK CO., INC.
Pacific Electric Building
Los Angeles, Calif. 10014
Toilet locks

PARAMOUNT ALL-PURPOSE VENDING EQUIPMENT INC.
1470 South Michigan Ave
Chicago, Ill. 60605
General purpose vendors

PARRISH METAL-CRAFT CO.
1 East State Street
Geneva, Ill. 60134
Pens, pencils, sanitary napkins, contract work
Bulk, cookies, candy, gum

PATTERSON INT'L INC.
10 Roakwood Bldg.
Cincinnati, Ohio 45202
Postcards

PERK-ETTE, INC.
1470 South Michigan Avenue
Chicago, Ill. 60605
Fresh brew coffee

POLICY-MATIC CORPORATION
P.O. Box 1163
1168 Atlanta St.
Marietta, Georgia 30062
Insurance

POLYCO INC.
(Div. of Fullview Ind.)
3602 South Jason
Englewood, Colorado 55429
Bags, wire garment hangers

J. B. POST CO.
66 Oxford Street
Wilkes-Barre, Pennsylvania
Ice

POSTAGE STAMP MACHINE CO., INC.
2008 Utica Avenue
Brooklyn, New York 11234
Stamps, post cards

PUBLISHERS VENDING SERVICES, INC.
250 East Fifth Street
St. Paul, Minnesota 55101
Newspapers, magazines, books, sundries

RAM JET CAR WASH DIV.
2527 Second Ave, North
Leeds, Alabama 35094
Car wash equipment

REDWOOD MACHINE CO., INC.
1703 Peoria Rd.
Springfield, Ill. 62700
Notebook paper, pens & pencils

ROBCO MFG. CORPORATION
235 West Main Street
Patchogue, Long Island, New York
Dryclnrs., washers, extractors, packaged gum, laundry supplies, contract work

ROCK-OLA MFG CORPORATION
(Subsidiary of Rock-Ola Manufacturing Corporation)
800 North Kedzie Avenue
Chicago, Ill. 60651
Fresh brew coffee, hot choc., bulk soup, tea, books, cigarettes, canned soft drinks

ROWE-AC MFG.
Troy Hills Rd.
Whippany, N.J.
Cigarettes, post-mix drinks, batch fresh brew-single cup fresh brew coffee, hot choc., tea, soup, candy, pastry, hot and cold pkgd. food, sandwiches, pkgd. gum, bill changer, coin handling equipment, components

RUDD-MELIKIAN, INC.
300 Jacksonville Road
Warminster, Pa. 18974
Single cup fresh brew, liquid concentrate, powdered coffee, tea, soup, hot choc., cartoned milk, hot-cold pkgd. food, pastry, cookies, crackers, fruit, post mix drinks.

S AND S PRODUCTS, INC.
West Grand Avenue
Lima, Ohio 45802
Bottled-canned drinks,

S AND S VENDING MACHINE CO.
670 Lincoln Avenue
San Jose, Calif. 95126
Ice

SAHARA PRODUCTS
(Division of McGraw-Edison Corp.)
3736 N. Booth St.
Milwaukee, Wis. 53201
Laundry supplies

SCHERMACK PRODUCTS CORP.
1164 West Baltimore Avenue
Detroit, Mich. 48202
Stamps

SCHOENBACH COMPANY
715 Lincoln Place
Brooklyn, N.Y. 11216
Stamps, combs, handkerchiefs, napkins, coin operated scales

THE SEEBURG CORPORATION
1500 North Dayton Street
Chicago, Ill. 60622
Cigarettes, single cup fresh brew, soup, tea, hot choc., post mix drinks, bottled and canned soft drinks, candy, cookies, cartoned milk, pastry, components, crackers

SELECTIVEND CORPORATION
1111 South 12th Street
Kansas City, Kans. 66105
Bottled & canned soft drinks

SERV-O-MATIC INC.
P.O. Box 663
Des Moines, Iowa 50303
Coffee, hot chocolate, soup, tea

WILLIAM F. SHEPHERD, INC.
1747 Central Avenue
Cincinnati, Ohio 45214
Candy, cookies, detergent, bleach, contract work

SHIPMAN MANUFACTURING CO.
1320-30 South Lorena Street
Los Angeles, Calif. 90023
Cigarettes, candy, cookies, gum, stamps, insurance, contract work

SHUFORD ENTERPRISES, INC.
P.O. Box 1742
Hickory, North Carolina 28601
Return bottles vender

E. J. SHURTZ MFG. CO.
240 West Tenth Street
Wichita 2, Kans. 67201
Ice

SIDEWALK VENDING
45 Bergen St.
Brooklyn, N.Y. 11201
Plastic lamenting & post cards

SKILL VENDING SALES, INC.
440 West Ontario St.
Chicago, Ill. 60610
Shoe shine machine

SOLUPAK COMPANY
5727 West 36th Street
Minneapolis, Minn. 55416
Laundry supplies, foot vibrators, car wash machine

SONDO ENTERPRISES
2107 Bellevue Ave.
Los Angeles, Calif. 90026
Fresh-brew coffee, instant coffee

SPECIALTY ENGINEERING CORP.
9030 Premier Row
Dallas, Texas 75207
Pre-mix drink, vending machine components & supplies

SPEEDEE CAR KLEEN
(Div. of Rexarc, Inc.)
East Third St.
West Alexandria, Ohio 45381
Car wash equipment

(Continued on page 71)

VENDING MACHINE MFRS.—TYPE EQUIP. PRODUCED

STAMPAK
(Div. of Inter-American Stamp Vending Corp.)
45 Bergen
N.Y., N.Y.
Postage stamps

STANCRAFT
(Division of Standard Packaging Corporation)
250 West 57 St.
New York, N.Y. 10019
Greeting cards, hosiery

STANDARD CHANGE-MAKERS, INC.
(Subsidiary of The Nik-O-Lok Co., Inc.)
422 East New York Street
Indianapolis, Ind. 46202
Coin changers, currency changers, components

STANDARD-HAVARD METAL TYPER, INC.
1318 North Western Avenue
Chicago, Ill. 60622
Identification discs, name plates

STEELMADE, INC.
2182 Market St.
San Francisco, Calif. 94102
Canned hot food, bottled-canned soft drinks

L. STEINER MFG. CO.
45 Bergen Street
Brooklyn N.Y. 11201
Stamps, post cards

STONER MFG. CO.
(Division of The Vendo Company)
328 Gale Street
Aurora, Illinois 60506
Candy, mints, gum, cookies, cigarettes, pastry,
instant coffee, hot chocolate, tea, hot canned
food

SUPERIOR MFG. CO.
P.O. Box 262
9110 Terminal Ave
Skokie, Ill. 60078
Cigarettes, cigars, gum, hot dogs

U. S. VENDING CORPORATION
140 53rd Street
Brooklyn, N.Y. 11232
Ice cubes

UNEEDA SHOE SHINE MACHINE CO.
(Subsidiary of Acme Sales Co.)
552 West 53rd Street
New York, N.Y. 10019
Shoe Shine Machines

UNITED JET WASH
(Div. of United Lent Allo, Inc.)
2605 North 27 St.
Lincoln, Nebraska 68503
Car wash equipment

UNIVERSAL METAL PRODUCTS
(Div. of Universal Match Corp.)
5661 National Bridge Ave
St. Louis, Mo. 63120
Vending machine components & supplies

UNIVERSAL VENDORS, INC.
1616 Walnut St.
Philadelphia, Pa. 19103
Candy bars, cookies, crackers, gum, cigar,
cigar packs, snacks

VACMANCO
97 Main St.
Schwenksville, Pa. 19473
Car wash equipment

VAC-UR-CAR, INC.
8337 North Christiana
Skokie, Ill. 60076
Vacuum cleaner for cars & trucks

VEND-A-BOX, INC.
321 York St.
Newport, Ky. 41071
Popcorn

VEND-A-MATION, INC.
3745 Spaeth St.
Cincinnati, Ohio 45223
Coin changers

THE VENDO COMPANY
7400 East 12th St.
Kansas City, Mo. 64126
Pre-mix & bottled soft drinks, cartoned milk,
juices, ice cream novelties, coffee (instant &
fresh brew), hot chocolate, hot & cold pack-
aged food, cookies, crackers, nuts, currency
changers

VEND-O-MATIC SALES, INC.
6413 Goodrich Ave
Minneapolis, Minn. 55426
Hot canned foods, canned soft drinks, vending
machine components & supplies

VENDOR MFRS., INC.
1319 Lewis St.
Nashville, Tenn 37210
Bulk products

VENDORLATOR MFG. CO.
(Div. of the Vendo Co.)
Pinedale Plant
Spruce & Ingram Streets
Fresno, Calif. 93706
Bottled, canned & pre-mix soft drinks

VENDOTRONICS CORP.
572 Merrick Rd.
Lynbrook, N.Y. 11563
Popcorn

VEND-RITE MFG. CO.
(Div. of R. J. Tennes & Co., Inc.)
1536 North Halsted St.
Chicago, Ill. 60622
Laundry supplies, laundry bags, pens, pencils,
sanitary napkins, cookies, crackers, packaged
gum, insurance, coin changers

VICTOR PRODUCTS CORP.
901 Pope Ave
Hagerstown, Maryland 21740
Pre-mix, post-mix, bottled and canned soft
drinks, instant coffee, hot chocolate, soup, tea,
canned & bulk juice, coin changers

VICTOR VENDING CORP.
5711 West Grand Ave
Chicago, Ill 60639
Bulk candy, nuts, ball gum, pens & pen re-
fills, coin changers

WEBEN PRODUCTS, INC.
(Div. of Weben Industries, Inc.)
1616 Anson Rd.
Dallas, Texas 75235
Car wash equipment

**WESTERN INDUSTRIES, INC. PARKING
CONTROLS DIVISION**
2744 West 36th Place
Chicago, Ill. 60632
Tickets, coin-operated parking gates

WESTINGHOUSE ELECTRIC CORP.
(Automatic Merchandising Division)
653 Page Boulevard
Springfield, Mass. 01101
Bottled & canned soft drinks, coffee (fresh-
brew, single cup) hot chocolate, soup (cup),
tea

WOODMASTER
P.O. Box 3161
Madison, Wisconsin 53704
Firewood, Charcoal, press-to-logs, other bulky
items (packaged or loose)

in colleges and universities • restaurants • theatres • lobbies • laundromats • travel terminals

you can win in any vending market
with this **PROFITABLE PAIR**



Model 77 CANDY VENDOR

VENDS candy, cookies, crackers, gum and mints • CAPACITY: 340 items (190 candy, 150 gum and mints) • 11 COLUMNS (8 candy, 3 gum or mints) • MANUAL COIN MECHANISM, with mechanical totalizer and 1-4 nickel changemaker • VENDS AT 5¢ and 10¢—accepts nickels, dimes and quarters • DIMENSIONS: 58" high by 35½" wide by 12" deep • SHIPPING WEIGHT: 324 lb. NET WEIGHT: 298 lb.

Model 86 CIGARETTE VENDOR

VENDS all cigarettes—regular, king, soft packs, boxes • CAPACITY: 510 packs • 14 SELECTIONS, with automatic match dispenser • MANUAL COIN MECHANISM, with mechanical totalizer • VENDS FROM 5¢ to 50¢ at 3 different prices. Accepts nickels, dimes, quarters • DIMENSIONS: 58" high by 35½" wide by 12" deep • SHIPPING WEIGHT: 310 lb. • NET WEIGHT: 284 lb.

What a pair of salesmen for the man who's just getting started as well as for the old pro. The Model 77 Candy Vendor also vends cookies, crackers, gums and mints. Has 11 columns—sells 340 items. The Model 86 Cigarette Vendor sells all kinds—regulars, kings, soft packs, boxes. Tremendous 510-pack capacity. Both by Rowe, world leader in quality. Both will do wonders in any market.

See your Rowe distributor today for his deal on this profitable combination. You can't lose.

Rowe[®]
AC
MANUFACTURING

Troy Hills Road, Whippany, New Jersey

STATE ASSOCIATIONS AND COUNCILS OF THE VENDING INDUSTRY

National Automatic Merchandising Association
 Pres. Carl Millman
 Automatic Merchandising Corp.
 2502 West North Avenue
 Milwaukee 5, Wisconsin
 Tel: HI 5-4473

Alaska
 (Included in the Northwest Council of N.A.M.A.)

Arkansas Automatic Merchandising Association
 Exec. Secy. Charles A. Stewart
 609 Rector Building
 Little Rock, Arkansas

California Automatic Vending Association
 (A Council of N.A.M.A.)
 Pres. Dwight Dickinson
 Bay Cities Automat Co.
 2196 Palou Ave.
 San Francisco, California
 Tel: (415) MI 8-6870

Canadian Automatic Merchandising Association
 Secy. Vernon Lang
 331 Bloor Street, West
 Toronto 5, Ontario, Canada
 Tel: 9-247341

Colorado
 (No formal organization—1958)

Connecticut Automatic Merchandising Council
 (A Council of N.A.M.A.)
 Pres. Morris Gottlieb
 National Automatic Services, Inc.
 20 Victory Street
 Stamford, Connecticut
 Tel: (203) 324-6925

Florida Automatic Merchandising Association
 Pres. Fleming W. Conyers
 Kwik Kafe of N. Florida, Inc.
 3111 Spring Park Road
 Jacksonville 4, Florida

South Florida Vending Association
 Pres. Van Myers
 Wometco Vending of S. Florida, Inc.
 400 North Miami Avenue
 Miami, Florida
 (305) Franklin 4-6262

Georgia Automatic Merchandising Council
 (A Council of N.A.M.A.)
 Pres. Lee (Bud) Wilkie
 Macke Southern Vending
 P.O. Box 10999
 Station A.
 Atlanta, Georgia

Idaho
 (Included in the Northwest Council of N.A.M.A.)

Kansas
 Exec. Secy. Charles W. Huston
 Kansas Tobacco, Candy Distributors and Vendors, Inc.
 1216 Filmore
 Topeka, Kansas

Kentucky Association of Tobacco Distributors
 Don Greene
 P. O. Box 8096
 Lexington, Kentucky

Kentucky Vending Association
 Pres. W. H. Threlkeld
 Canteen Company
 6228 Strawberry Lane
 Louisville 14, Kentucky
 Tel: EM 6-0361

Louisiana Council of Automatic Merchandising
 (A Council of N.A.M.A.)
 Pres. Richard A. Hoose
 New Orleans Cigarette Service
 730 Pierce St.—P. O. Box 19387
 New Orleans 19, Louisiana
 Tel: 488-6626

Maryland Automatic Merchandising Council
 (A Council of N.A.M.A.)
 Pres. Herbert L. Bent
 Benroy Vending Co., Inc.
 1506 S. Caton Ave.
 Baltimore 21227
 Tel: (301) MI 4-8900

New York Automatic Vending Association
 Pres. Harold Folz
 Folz Vending Co.
 P. O. Box 5
 Oceanside, L. I., New York
 Tel: OR 8-3600

New York Cigarette Merchandisers Association, Inc.
 Pres. Max Weiss
 M. W. Vending Company
 4315 Church Avenue
 Brooklyn, New York
 Tel: HY 3-9510

Vending Association of Buffalo
 Pres. Henry D. Waters
 Vending Association of Buffalo, New York
 c/o Canteen Division of Automatic Canteen Co. of America
 1712 Main Street
 Buffalo, New York 14209

North Carolina Vending Association, Inc.
 Vice-Pres. Richard D. Coonen
 Macke Industrial Vending Co.
 2701 Rozzells Ferry Road
 Charlotte 1, North Carolina

Massachusetts Automatic Merchandising Council
 Managing Director, Walter R. Guild
 The Guild Associates
 261 Franklin Street—Room 418
 Boston 10, Massachusetts
 Tel: HU 2-1660

Michigan Tobacco & Candy Distributors & Vendors Association
 Pres. Lester Greenspan
 Nor-Les Sales Company
 2676 - 18th Street
 Detroit, Michigan

Vending Association of Minnesota
 Pres. David Bach
 Bell Vending Company
 315 S. Broadway
 Rochester, Minn.

Mississippi Automatic Merchandising Association
 Pres. Robert W. Lott
 Lott Vendors, Inc.
 314 West Fortification Street
 Jackson, Mississippi
 Tel: FL 5-4758

Missouri
 N.A.M.A. Legislative Chairman Harlan Denkmann
 Automatic Canteen Co. of St. Louis
 6757 Olive Street Road
 St. Louis, Missouri
 Tel: PA 5-2600

Montana
 (Included in the Northwest Council of N.A.M.A.)

Nevada
 Legislative Chairman Bruce Sutton
 Sutton Vending Service, Inc.
 818 South Main Street
 Las Vegas, Nevada
 Tel: DU 4-1670

New Jersey Automatic Merchandising Council
 (A Council of N.A.M.A.)
 Pres. Nat Levy
 Automatique New Jersey, Inc.
 378 Schuyler Ave.
 Kearny, New Jersey
 Tel: (201) 997-2000

North Dakota Vending Association
 Pres. Irv Linderholm
 F. M. Coffee Vending Service
 419 North Pacific Avenue
 Box 1211
 Fargo, North Dakota

Northwest Automatic Merchandising Council
 (A Council of N.A.M.A.—includes the states of Alaska, Idaho, Montana, Oregon and Washington)

Northwest Automatic Merchandising Council
 Pres. Fred W. Conrad
 Rogue Valley Vending Service
 27 South Grape
 Medford, Oregon
 Tel: (503) 772-5026

Ohio Automatic Merchandising Association
 Pres. Robert Walker
 Selective Vending, Inc.
 361 West Longview Ave.
 Mansfield, Ohio
 Tel: (419) 522-4782

Oklahoma Automatic Merchandising Council
 (A Council of N.A.M.A.)
 Pres. Monty Bradley
 Interstate Vending Co.
 2200 N. Broadway
 Oklahoma City
 Tel: (405) 235-6474

Oregon
 (Included in the Northwest Council of N.A.M.A.)

Pennsylvania Automatic Merchandising Council
 (A Council of N.A.M.A.)
 Pres. Albert M. Rodstein
 Macke Variety Vending
 1213 N. Fifth St.
 Philadelphia, Pa.
 (215) PO 3-9600

South Carolina Automatic Merchandising Association
 (1138 Bull Street, Columbia, South Carolina)
 Pres. Doug Cromer
 Anderson Vendo-A-Matic Service
 507 Walden Parkway
 Anderson, South Carolina
 Tel: CA 5-8696

South Dakota Music and Vending Association
 Pres. John Trucano
 Black Hills Vending
 Deadwood, South Dakota

Texas Merchandise Vending Association, Inc.
 Pres. John Ogden
 Automatic Vending Company
 1050 Eastside
 El Paso 15, Texas
 Tel: PR 2-5228

Washington
 (Included in the Northwest Council of N.A.M.A.)

West Va. Music & Vending Assoc.
 1301 Winchester Ave.
 Martinsburg, W. Va.
 Pres. Dilman Dehaven

Wisconsin Automatic Merchandising Council
 (A Council of N.A.M.A.)
 Pres. George Terris
 Stacy Brothers Co.
 5235 North Ironwood
 Milwaukee
 (414) 332-8500

FOREIGN VENDING MACHINE MFR'S

BELGIUM

DYNAVEND
 66, Bd. de l'Imperatrice,
 Brussels.

DENMARK

AUTOMATFABRIK DANSK
AUTOMATFABRIK
 Wilders Plads,
 Copenhagen.

ESBJERG UNDERHOLDING
AUTOMATFABRIK
 Gamle Faergevej,
 Elsbjerg

PAUL KRISTENSEN
 Damhus Boulevard 55,
 Copenhagen-Valby.

INTERNATIONAL VIBRATOR COMPANY
 Dyrehovegaarsvg 2,
 Lyngby.

SOREN WISTOFT & COMPANY A/S.
 Nikolajvej 4-6,
 Copenhagen.

FRANCE

ETS. BONNET
 Villefranche Sur Saone.

ETS. BONZINI
 34-36, Rue Desire Vient,
 Bagnolet/Seine

D.E.M.
 34, Rue Lebour,
 Montreuil.

ETS. DRANCY
 72, Rue Jean Legalleux,
 Ivry (Seine)

SOCIETE INDUSTRIELLE D'APPAREILS
AUTOMATIQUES
 10, Rue Leontine,
 Paris.

GERMANY

TH. BERGMANN & COMPANY
 Eimsbuttelstrasse 64-66,
 Hamburg-Altona.

HENRICH BRUNSWIG
 Sternstrasse 117,
 Hamburg.

FERDINAND FLORSTEDT
 Flottenstrasse 57,
 Berlin-Reinickendorf.

GLOBUS-AUTOMATEN GMBH
 Schleusenstrasse 18,
 Frankfurt am Main.

MAKO APPARATEBAU
 Frankfurterstrasse 74,
 Offenbach/Main.

GREAT BRITAIN

ALDEBERT ENGINEERING CO. LTD.
 Aldebert Works,
 Aldebert Terrace,
 London, S.W. 8.
 (Cigarette & Confectionery Machines)

AUTOBARS CO. LTD.
 4-6, High Street,
 Brentford,
 Middlesex.
 (Change-Givers, Hot & Cold Drink Machines)

AUTOMAT LTD.
 173, Elmers End Road,
 Beckenham, Kent.
 (All Types)

BIRMINGHAM AUTO VENDERS LTD.
 24, Station Road,
 Erdington, Birmingham 23.
 (All Types)

BRECKNELL, DOLMAN & ROGERS LTD.
 Pennywell Road,
 Bristol 5.
 (Cigarette & Confectionery Machines)

BRITISH AUTOMATIC CO. LTD.
 14, Appold Street,
 London, E.C. 2.
 (All Types)

BURT. J. (CHISWICK) LTD.
 93, High Road,
 Chiswick W. 4.
 (Cigarette Machines)

CHADBURNS (LIVERPOOL) LTD.

Vender Sales Division,
 Park Lane Works,
 Netherton,
 Bootle 10, Lancashire
 (Cold Drink Machines)

DEAN BROS. (ENGINEERS) LTD.
 Haydn Road,
 Nottingham.
 (Confectionery & Match Machines)

DITCHBURN VENDING MACHINES LTD.
 Dock Road,
 Lytham,
 Lancashire.
 (Hot & Cold Drink Machines)

ELECTRIC SHOP DEVELOPMENTS LTD.
 22, High Street,
 Fulham, S.W. 6.
 (Universal Venders)

FISHER & LUDLOW LTD.
 Vending Division,
 Bordesley Works,
 Clyde Street,
 Birmingham 12.
 (All Types)

GLOSTER EQUIPMENT LTD.
 Hucclecote,
 Gloucester.
 (All Types)

THE RANK ORGANISATION
 Kershaw Division,
 200, Harehills Lane,
 Leeds 8.
 (All Types)

NATIONAL AUTOMATIC MACHINES LTD.
 54/56, Minerva Road,
 Park Royal,
 London, N.W. 10.
 (All Types)

PHOTO-ME STUDIOS LTD.
 Lyon Road,
 Hershaw Factory Estate,
 Hershaw,
 Surrey.
 (Photographic Machines)

ROLLASON AEROCESSORIES LTD.
 Croydon Airport,
 Surrey.
 (Hot & Cold Drink Machines)

SANKEY, JOSEPH & SONS LTD.
 Vendo Division,
 Hadley Castle Works,
 Wellington,
 Shropshire.
 (All Types)

W. M. STILL & SONS LTD.
 29-31, Greville Street,
 London, E.C. 1.
 (Hot & Cold Drink Machines)

HOLLAND
MACHINEFABRIEK COULIN
 Vlaardingen.

DESCO (VAN DESSEL)
 Rechthuislaan 8,
 Rotterdam.

N. V. HANDEL MAATSCHAPPIJ HOLDEEN
 Willem Buijwegstraat 65,
 Rotterdam.

ITALY
BREVETTI F.A.S.N.A.
 Via Monte Rosa 35,
 Turin

FIDAM
 Via Senato 24,
 Milan.

GAETANO SPATAFINA
 Via Maso Di Bianco 10,
 Florence.

SIDAM
 Via RuBiana 52,
 Turin

E. BIANCHI VELO
 Linea Primato
 Automatic Vendors Div.
 Offices: Via Fantoli, 11
 Milano, Italy
 Phone 503441
 Factories: Via Alessandria, 1
 Pontecurone (Alessandria)
 Italy

**NEW
NEW
NEW**

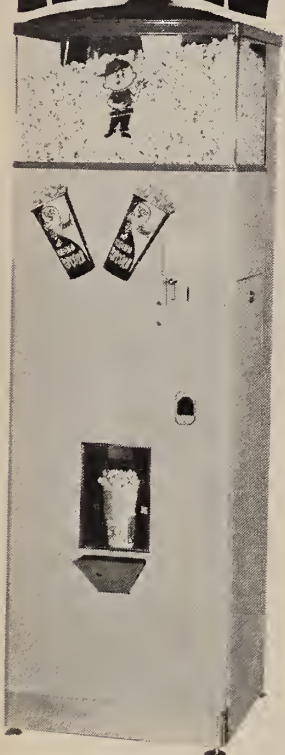

FEDERAL'S CUP DROP POPCORN MACHINE

The newest and most exciting popcorn machine to hit the market is Federal Machine Corporation's cup drop unit.

With a cup drop machine you have no sanitary problems, no popcorn mess on floors, no sack loss, no tipping sacks. What's more, this 19" x 19" machine brings more profit, because research has proven customers prefer vended popcorn in cups, three to one, over popcorn in sacks. Machine is weatherized, has adjustable portions, large 130 cup capacity and heating element to keep popcorn always hot . . . always fresh.

Get all the details today. And when you write or call, ask about the Federal pay-as-you-earn finance plan!

**Federal Machine
CORPORATION**

100-104 SW Fourth St. • Des Moines, Iowa

thanks a million



DEBBIE
REYNOLDS



KAY
STARR



JANUARY
JONES



JANE
MORGAN



BARBARA
MC NAIR

James Darren, Frankie Avalon, Vicki Carr, Jody Miller, Bobby Vee, Freddie Bell and Roberta Lynn, Mary Kaye and all the other American artists who have joined our International Stars in providing the very best in entertainment for SCOPITONE

TO THE HUNDREDS OF RESTAURANTS, NITE CLUBS, TAVERNS AND HOTELS for providing SCOPITONE with the opportunity to give their patrons great musical entertainment that they can SEE as well as HEAR in living color and high fidelity sound.

TO HARMAN ENTERPRISES for the outstanding musicals they have produced for the enjoyment of our SCOPITONE audiences.

TO WILLIAM MORRIS AGENCY, INC., for its advice and counsel.

... AND A MILLION THANKS TO OUR U.S. DISTRIBUTORS WHO ARE RESPONSIBLE FOR EXPOSING THIS EXCITING NEW THEATER OF ENTERTAINMENT TO CUSTOMERS ACROSS THE COUNTRY.

A limited number of distributorships in certain areas are open to inquirers with reasonable capital available.

*address all communications to:
vice president, SCOPITONE, Inc.
420 Lincoln Road, Miami Beach, Florida
area code 305 • 532-3404*



Scopitone

a product of TEL•A•SIGN, Chicago, Ill.

CHICAGO OFFICE: 3401 W. 47th St.
FR 6-8800
NEW YORK OFFICE: 501 Madison Ave.

Bally Mfg. Ships Beauty Beach Bingo

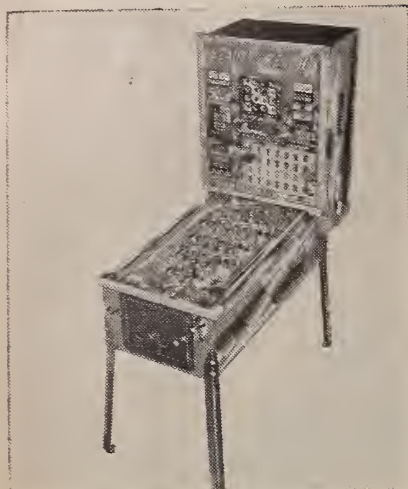

Bally BEAUTY BEACH

CHICAGO—After a lapse of several months, Bally Manufacturing Company, Chicago, has again assigned production lines to limited output of a bingo-style pinball game, which—with an obvious bow to the previous model, "Border Beauty"—is named "Beauty Beach."

"Soaring demand for Bally flipper games and slot machines," explained Bill O'Donnell, Bally president, "prevented us from us fully serving the bingo market with 'Border Beauty.' The pressure from bingo operators both in the U.S. and abroad, however, has forced to adjust our lines to permit a modest flow of bingo equipment to the trade."

"Instead of merely continuing 'Border Beauty' production, we elected to offer an entirely new improved model, 'Beauty Beach,' which test operators proclaim as the greatest bingo ever to come out of Chicago."

"In addition to new 'bathing beauty' styling and numerous mechanical refinements, the big innovation in 'Beauty Beach' is the new Triple Score Feature. The Double Score Feature is, of course, retained, but now players can buy either Double or Triple Scores, and the fact that they regard the feature as well worth buying is proved by collection reports of test locations where 'Beauty Beach' consistently tops 'Border Beauty.'"

"Retained also is the scoring simplicity of the 20-hole board and 20-number card, which called into action a whole new corps of players when 'Border Beauty' was introduced. Retained also are the 4-color zones, which replace the old fashioned lines and sections, the A, B, C Mystic Lines and the 4-Star feature of 'Border Beauty.'"

"Needless to say, the old favorite Red Letter Games, Pick-A-Play Buttons and other traditional bingo features are also built into 'Beauty Beach,' as is the combination nickel-quarter chute which is an optional alternative to dime only or nickel only coin equipment."

"In view of the restricted production, I sincerely hope operators will bear with us while we try to fill the pent up demand for the previous beau-

Toohy Named Seeburg V.P.; Exits Cash Box



MARTY TOOHEY

CHICAGO—Martin (Marty) T. Toohey has joined the Seeburg Corporation as a regional vice president in the Eastern United States, according to an announcement by William Adair, executive vice president sales. "We are pleased to have him join our team," said Adair. "He knows the people in our industry from his many years contacting them for both Billboard and Cash Box," the Seeburg executive pointed out.

Toohy has been associated with Cash Box the past six years and has been general manager of that trade publication's coin machine and vending division. Previously, he was an account executive for two years with the De Perri Advertising Agency in New York City, an advertising organization specializing in vending and industrial marketing.

Toohy began his association with the Coin Machine Industry back in 1955 when he headed the coin machine advertising sales department for Billboard.

Toohy and his wife, Maureen, recently celebrated the arrival of a baby boy, their fifth child. With their three daughters and two sons, the Tooheys reside in Englewood, New Jersey.

For the next several weeks, Toohey will be at the Seeburg Corporation's main plant in Chicago and will take up the new post in about a month. He is a World War II veteran and served in the United States Navy. He attended New York University and majored in marketing.

ty of the bingo class with our new improved, more beautiful beauty—"Beauty Beach"

Cash Box Appoints Adlum Coin Div. Mgr.



ED ADLUM

NEW YORK—Joe Orleck, president and publisher of Cash Box, has announced the appointment of Ed Adlum to the post of general manager of the magazine's coin machine and vending division to replace Marty Toohey, recently named Eastern vice president by the Seeburg Corp.

Adlum has spent nearly two years in the Cash Box coin machine dept. working directly under Toohey. He previously worked in the circulation promotion Dept. of Look Magazine.



Eastern Flashes

A MOMENT OF SORROW—One by one, members of the coin machine trade became shocked and saddened as they learned that veteran Morris Gisser had passed away Sunday evening, August 1st, from a heart attack. Morris was a giant in this business—as Mickey Anderson stated, "one of the biggest, maybe the biggest"—and his passing was received with deep emotion by literally thousands of his customers and friends throughout the world. Perhaps the most fitting epitaph delivered was spoken by Cleveland Coin's Dave Liebling who said, "our industry has certainly lost a valuable asset when Morrie died—we can never replace him." . . . Another sad note was struck when the trade learned of the recent death of coinvet and record distributor Jake Friedman. Jake, who died at the age of 64, is survived by his wife Esther, son Gerald and two daughters Mrs. Jack Gelbart and Mrs. Washington Falk III and two sisters.

OUR LOSS, THEIR GAIN—Marty Toohey, one of the most articulate men on all phases of the coin machine business, has excited the coin machine department of Cash Box where he held reign for over five years and has picked up the weighty task of Seeburg vice president for the Eastern terrain. Marty's knowledge of the business, his polish and journalistic talents have established an example that'll be mighty tough to duplicate. Be that as it may, the job has fallen into the hands of Ed Adlum, familiar to most coinmen in the metro New York area and to many across the nation via frequent phone conversations. Ed will be getting to know all of you at the MOA conclave next month, meeting you and greeting you and shaking you down for news items. Laughing on the outside, crying on the inside, good luck, Marty Toohey!

HOT SALES IN THE SUMMER—Plenty of action has been reported in the distributor precincts during these normally slow summer months. Tommy Greco at Greco Bros. Dist. in Glasco, N.Y. reports excellent action on Rock-Ola's 'Grand Prix II' phono at both the main office and at the Albany branch where Jule Oldshime holds down the fort. Musical Distributors exec Harold Kaufman says he's riding a tidal wave of sales on Wurlitzer's 2900 juke which is popping up in more and more locations all over the metro New York area. Harry Berger, just back from a restful vacation at Hollowville, New York, is doing a job with reconditioned shuffles and also with the U.S. Billiards Pro lineup of 6-pockets. Parts Dept. Mgr. Morty at Harry's place spent last week vacationing and this week it's gal-Friday Billie Sporko's turn to head back to the Carolina hills and rest her weary bones.

NEW PRODUCTS—The Irving Kaye Co. of Brooklyn recently intro'd their new non-coin 6-pocket table the 'Ambassador' and sales exec Howard Kaye is gearing for heavy action. The table, designed in the Kaye "high-style," is mighty nice to look at and ought to find its way into many parlors and recreation rooms. . . . Hank Swartz, Intersphere exec, forecasts big things for his 'Colorama' audio-visual machine as he continues to build up his film supply with the kind of musical entertainment he feels will punch out those two-for-a-quarter plays on location.

WHEELING AND DEALING—Urban Industries chief Nat Bailen says his firm has been enjoying good business throughout the U.S.A. in trading with owners of Mills Panorams for his lineup of new film machines. Nat wishes to advise the trade that he's interested in trading with any operator with either Mills or Capital units. Nat also reports that Alvin Gottlieb of D. Gottlieb & Co. has been doing his part to help correct the situation in Kentucky where Governor Breathitt has been swaying back and forth in his considerations to ban the operation of pin games in that state. In a story in the Louisville Times, Alvin was quoted as replying to the Governor's plan to ask the next session of the state legislature to ban the pins: "Over the years, the pinball industry has become a political football. It's like the story of Jimmy Durante, relaxing on a Florida beach and letting two flies walk on his big schnoz. All of a sudden one of the flies bit him and Durante said so long as there was one wise guy in the crowd, everyone had to get off."



Philadelphia Fare



Active Amusement prexy Joe Ash says Gottlieb's new 'Dodge City' pin game is perking up business both for him and for his operator customers reporting fine action with the piece on location. The firm's sales ace Fred Pliner, who just recently returned from vacation, is all enthusiastic with Rock-Ola's "sleeper" the compact 'Starlet' phono. The box is definitely running ahead of the original 'Princess Royal' in sales, he claims. Active's bookkeeper, Rhea Katz, is out of the hospital now after an eye operation. . . . ABC Consolidated president Jack Beresin and Dave Rosen were named to help promote the benefit game between the Philadelphia Eagles and the Detroit Lions on August 1st at Franklin Field. They were among a selected group of Philly leaders selected to help promote the football game for the benefit of the Philadelphia Association for Retarded Children. Mayor James Tate is honorary chairman of the benefit game. . . . Dave Rosen recently completed negotiations to provide full banking accommodations for his new 'Filmotheque Diskotheque' audio-visual entertainment unit, and says Dave, it's "full steam ahead" now. Stated the coinvet, "banking accommodations have committed themselves to us to the availability of a \$10,000,000.00 line for the handling of 'Filmotheque-Diskotheque'. . . . Banner Specialty exec Jimmy Ginsburg is striking golden notes on the register with Wurlitzer's Golden Bar phono feature, he says. Also cooking for the distrib these days is Automatic Products' popular 'Candyshop' vendor. . . . Marvin Stein and Baltimore branch manager of Eastern Music Systems Zav Houzepian huddled for a spell last week working out sales and promotional plans for the Seeburg phono and vending lineup.

P.Z.P. Associates, Inc.
405 Poplar St.
New Haven, Conn.

ACCEPTS
THE CHALLENGE
SOMETHING NEW FOR THE
AMUSEMENT FIELD

KICK-IT
THE TABLE SOCCER GAME



We are seeking Distributors for areas all over the country. Please write to the above address if interested. Liberal discount prices available.



Chicago Chatter

Coinbiz was stunned last week upon hearing of the tragic, sudden death (Sun., Aug. 1) of Cleveland Coin's Morrie Gisser. Sales chief Dave Liebling and Ronnie Gold, Morrie's son-in-law, were grief-stricken over the news. . . . More heartbreak: Another tragic loss to coinbiz and the music industry was the death recently of Jake Friedman of Atlanta, after an illness of several months. . . . Chicago Coin's sales director, Mort Secore, looked up from a very busy desk to inform that ChiCoin has resumed full production on all amusement equipment for the coming Fall season. Mort sez the outlook for Fall is very good at ChiCoin. . . . Among the execs at the Seeburg Corp. who returned from business trips t'other day were Jack C. Gordon, Tom Herick and Bill Adair. A very busy man at Seeburg these days is Frank Luppino.

The big news at Bally Mfg. Co. this week is Bill O'Donnell's announcement to the domestic and foreign trade that the firm is back in production of bingo games, after a lapse of several months. Herb Jones advises that the newest Bally bingo version is "Beauty Beach." . . . We looked in on a new Seeburg discotheque installation at the Palmer House last week. We got the word from Stan Jarocki, of Seeburg. During our visit to the "Charade A Go-Go" Room we chatted with World Wide's Nate Feinstein, Harold Schwartz and Tom Higdon, who observed the installation. Latest report from the Palmer House's Fred Townsend is that it's a swingin' room now. . . . More sad news: Irv Webb (59) who was for many years associated with David C. Rockola (since 1934) died in his home in Altadena, Calif. last Tuesday, Aug. 3. He was in semi retirement of late.

Rock-Ola adchief George Hincher advises that everyone at Rock-Ola Mfg. is eagerly looking forward to the upcoming MOA Convention in the Pick-Congress Hotel (Sept. 11-13), and the NAMA Trade Show in Miami Beach (Oct. 16-19). . . . J. H. Keeney's Art (and Kay) Weinand just returned from a Florida vacation well tanned and relaxed. He's trying to clear the decks at Keeney in preparation for a sales trip to London. . . . Harry and Rose Silverberg expect to be in Chi for the MOA Conclave. Meanwhile, sales are up at W. B. Distribs., in Kansas City. A fast-moving item is the can cold drink vendor.

Williams Electronic Prexy Sam Stern, Herb Oettinger and Jack Mittel are holding down the fort while sales chief Bud Lurie is on the road again calling on distribs, and Bill DeSelm is on vacation. . . . Gil Kitt and Joe Robbins, of Empire Coin, visited the Grand Rapids branch with Edward G. Doris, executive vice pres. of Rock-Ola Mfg. Corp. On hand to greet them was Manager Dick Flaherty. Joe info'd that Dave St. Pierre is doing a bang-up job with Empire's vending line, especially the can cold drink vendor. . . . Susan Berger is helping her mother and dad (Mr. & Mrs. Sam (Frances) Berger) at Dynaball Co. Susan returns to her scholastic chores at Bateman in the Fall. . . . Nelson E. Coons, of Cardinal Vending, in Cleveland, is chairman for the forthcoming NAMA Convention, according to Prexy Richard Howard.

Dennis Ruber, co-head with Richard Uttanoff of D&R Industries, reports that his eastern sales trip was a whopping success. While there he added Si Lipp to the firm's sales force for the State of New York. . . . Al Rosen, head of Phoenix Postage Vendors Co., in Phoenix, Arizona, was a visitor in the Cash Box office last week. . . . It's good news from Hymie and Eddie Zorinsky, H. Z. Vending & Sales. The Fair Trade Law just passed thru both houses of the State Legislature and was signed by the governor. The law is in effect in Nebraska. . . . Mary Gillette, head of Phonograph Service Co., is a very proud mother. Her daughter Leslie was married, July 31, in St. Paul. Lucky groom's name is George Faricy. Leslie recently received her Masters Degree in Psychology and Counseling at Michigan State U. . . . We found Joe Kline and Stan Levin, et al, in a beehive of activity at Atlas Music Co. t'other day. Selling well at Atlas are vending, games and music equipment. Sam Kolber is on vacation this week.

Empire's Joe Robbins bemoans the fact that he often golfs with Sam Greenberg, Elliott Music, and Billy Knapp, Allied ABC, a couple of "golf hustlers" (a la Minnesota Fats). Joe explained that Sam and Billy make it a general point to conceal his ball if he drives well. Also, either Sam or Billy keep score (so who can beat them?) . . . MOA's Fred Granger announced last week that Capitol Records is in the fold for the convention. . . . Ray and Dick Brown, Brown Bros. Distribs, in Minneapolis, announced a change of address last week. The busy Twin Cities distrib is now located at 2321 Washington Avenue, North. . . . Heartfelt sympathies to Mrs. Audrey Brown on the death of her mother. Audrey is a sister of Ray and Dick Brown.

A. L. (Lew) Ptacek, prexy of Bird Music, in Manhattan, Kansas, is eagerly looking forward to the MOA Convention. Lew is a vice president of MOA, and very active in association affairs. . . . Construction is proceeding on schedule on the two additional floors at Gottlieb Memorial Hospital, according to Alvin Gottlieb. . . . Production is up to a furious pace at Midway Mfg. Co. Marcine Wolverton and Hank Ross had to acquire additional space elsewhere to keep up the production and shipping schedules.



Milwaukee Mentions

Although Sam Hastings, Hastings Distribs, tried very hard to retain his injured eye a unanimous opinion by several eye specialists was that it would have to be removed. Last Tuesday, Aug. 3 the operation was skillfully performed in a Milwaukee hospital. During Sam's convalescence his capable sons, Jack and Jimmy, are holding down the fort. . . . Joel Kleiman and Sam Cooper, co-heads of Pioneer Sales & Services, happily advise that Rowe coffee vendors are moving out to locations as rapidly as cold drink machines. Sales are also steady on Rowe-AMI "Diplomat" phonos, and amusement games. . . . Nate Victor, S. L. London Music Co., gathered up his wife and kiddies and left the city for a weeklong holiday (bet he catches some whoppers in Wisconsin's well stocked lakes). . . . United, Inc's, Harry Jacobs has been so swamped of late he's seriously considering adding personnel to his staff. Recently Chuck Meyers was appointed a sales rep covering Wisconsin and Northern Michigan. . . . When we chatted with Orville Carnitz, prexy of Badger Novelty Co., he dwelt on the upcoming MOA Convention, Sept. 11-13, in the Pick-Congress Hotel. Orv expects to be on hand with Dick Wegener, Ray Van Tour and Mike Papageorden of his staff. . . . Jerome "Red" Jacomet, Red's Novelty Co., is a very active director of MOA and will probably lead a Milwaukee contingent to the conclave. . . . Among the Wisconsin operators making the rounds in Cream City's coinrow last week were: Lou Alberfonti, Harold Summerfield, Ed Bartel, Bernie Schmith, Roger Bookmeier, Chuck Hartman, and Tony and Bob Zore.

MIDWAY MANUFACTURING COMPANY
10136 PACIFIC AVENUE, FRANKLIN PARK, ILLINOIS

WATCH FOR
Midway's
**NEW
SHUFFLE
ALLEY**



There's a **NEW** kind of record
with a **NEW** kind of sound

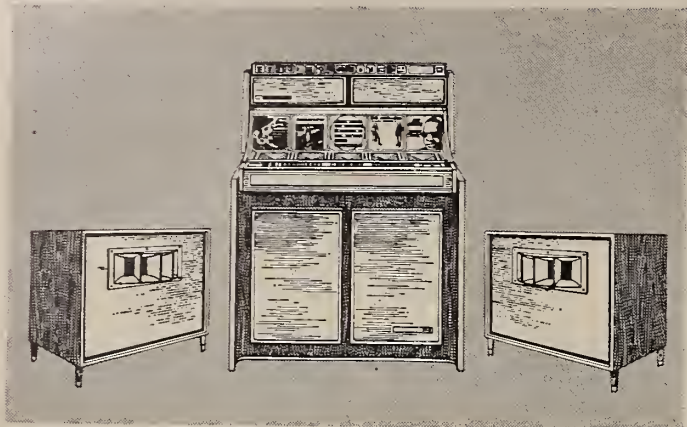

...it's a **NEW** form of public
ENTERTAINMENT!

And it belongs to you . . . alone, compliments
of your **Seeburg Distributor**. The **ONLY** pho-
nograph showcasing these profitable sounds
is the **SEEBURG LPC-480**.

To hear the sounds (and the facts)
just come in and see us, today.

OPERATORS SALES, INC.

4122 WASHINGTON AVE., NEW ORLEANS, LA. • 822-2370

IT'S **GOOD** BUSINESS TO DO BUSINESS
WITH **GOOD** RECONDITIONED EQUIPMENT

THE VERY FINEST IN
RECONDITIONED VENDING EQUIPMENT
IS THE SPECIALTY AT **VASCO**

Let us show you how you can turn your
Corsair cigarette machines into a brand
new look by converting your front door.

VASCO (Vendors Automatic Supply Corp.)

311 Scholes St., Bklyn., N. Y. • 212 EM 6-5700

PHONOGRAPHS

SEEBURG

OS-120	825
DS-100	825
AY-160	725
AY-100	725
AQ-160	625
AQ-100	625
Q-160	550
Q-100	550
220	495
KD-200	245
L-100	350
R-100	275
G-100	175

AMI

Diplomat	900
Tropicana	725
JAL	450
Continental 2-200	395
Continental 2-100	395
Continental 1-200	350
J-200	325
G-120	175
F-120	150

WURLITZER

2610-S	\$595
2410-S	350
2150	225
2100	195

ROCK-OLA

1475	\$395
1455-0	175
408 Rhapsody	645

BALL BOWLERS

CHICAGO COIN	
Majestic	\$830
Cadillac	795
Official	725

Grand Prize	650
Royal Crown	595
Gold Crown	550
Continental	450
Princess	325
Dutchess	350

UNITED

Polaris	\$895
Thunder	875
Futura	795
Fury	745
Lucky	595
Tropics	575
Southern Star	450
Classic	350

BASEBALLS

ChiCoin Big League	Write
ChiCoin All Star	\$225
ChiCoin Bullseye	125
Williams Tenth	
Inning	445
Williams Major	
Williams Oeluxe	350
Baseball	250
Williams Official	225
Williams Short Stop	195
Williams Pinch Hitter	225
Williams	
King of Swat	95
Bally Heavy Hitter	125
Bally Big Inning	125
Miday Oeluxe	
Baseball	245

SHUFFLES

Bally All the Way	\$375
Bally Super	325
Bally Official	125
Bally Oeluxe Club	125
Bally Lucky Shuffle	125

CHICAGO COIN

Gold Star	Write
Triumph	\$750
DeVillie	650
Spotlight	550
Strike Ball	450
Citation	375
Variety	245
Six-Game	195
Four-Game	150
Red Pin	125

UNITED

Action	\$495
Crystal	425
Viking	325
Dolphin	295
Oval	145
Lineup	225
Cyclone	125
Sure Fire	225
Flash	175
Zenith	150

ARCADE

ChiCoin Champion	
Rifle Range	\$395
ChiCoin Worlds Fair	
Gun	395
ChiCoin Shoot the	
Clown	250
Wms. Space Glider	\$195
Wms. Titan Gun	145
Midway Deluxe	
Shooting Gallery	125
Midway Flying Turns	395
Midway Raceway	295
Midway Ski Fun	175
Midway Target Gallery	150
Midway Target	
Gallery (2Pl)	195
ChiCoin Pop Up	425
ChiCoin All Star	
Hockey	325

ChiCoin Criss-Cross

Hockey	375
ChiCoin Ski Score	175
Wms. Mini-Golf	445
Wms. Road Racer	195
ChiCoin Big Hit	175
Bally All Star	125
Mutoscope Cross	
Country	275
United Pixie Bowler	125
ChiCoin Round The	
World Trainer	295
Southeast Speedway	325

FIVE BALLS

Wms. SkiClub	\$350
Wms. Alpine Clob	350
Wms. Merry Widow	395
Wms. Big Deal	250
Wms. Big Oaddy	275
Wms. King Pin	195
Wms. Three Coins	175
Wms. Valiant	225
Wms. Skill Ball	150
Wms. Jolly Jockey	175
ChiCoin Bronco	350
ChiCoin Sun Valley	225

GOTTLIEB

Goucho	\$325
Liberty Bell	345
Fashion Show	295
Flying Circus	245
Showboat	225
Lightning Ball	125
Miss Anabelle	125
Straight Shooter	125

BALLY

Hayride	\$275
Happy Tour	275
Bus Stop	395
2 In 1	365
Three In Line	295

Morris Gisser — "A Giant Of The Industry" — Passes Away Aug. 1st



MORRIS GISSER

CLEVELAND—Morris S. Gisser (63), president of Cleveland Coin Machine Exchange, and Cleveland Coin International, in this city, died suddenly after suffering a heart attack late Sunday night, August 1, in his home just before retiring.

Funeral services were held for Gis-

ser last Monday afternoon, August 2, in Cleveland. He was survived by his wife, Esther; two daughters, Mrs. R. A. Gold, and Roslyn Gisser, of Westchester, Pa.; a son, Sheldon Gisser; three brothers, a sister, and five grandchildren.

Gisser, a prominent, widely known coinman since 1937 (when he founded Cleveland Coin) was also active in three unrelated firms: Ansel Realty Co., Drexmore Realty Co., and Goodwill Loan Co. He was very active in temple affairs for many years. He often headed the fund raising drive for the Young Israel of Cleveland Temple. Gisser was also known to be a driving force in Israel Bond sales in the Greater Cleveland area.

Dave Liebling, sales manager of Cleveland Coin, tearfully stated "our industry has certainly lost a valuable asset when Morrie died. We can never replace him."

Liebling was associated with Gisser at Cleveland Coin for more than 20 years. Another associate is Ronnie A. Gold, Gisser's son-in-law.

Gisser had just recently returned from a whirlwind world wide sales trip for Cleveland Coin International, according to Liebling. He had been concentrating very heavily of late on the export phase of the business.

Pollak Lauds Results Of Rowe Discotheque

NEW YORK—As the Rowe big Discotheque sales and merchandising push nears the last lap of '65 . . . reports pour in of a smashing success!

"These are facts—not fiction and we can prove it!" said Fred Pollak, Marketing Vice President of Rowe AC Manufacturing, "I'm an optimist and I knew we had a real package—but the sales figures surprised even me! Present results indicate we'll more than top our highest previous estimates! It's been a great combination—Rowe and Killer Joe as our official advisor on everything Discotheque . . . he's given our program a real swingin' flavor.

"Now, here's satisfying proof" continued Fred Pollak, "you can't get away from these factual success stories we get from operators who've installed our DIPLOMAT. All have found it easy to create the excitement and bring in the crowds by following our merchandising suggestions program. Once they're in—they stay, and come again—you just can't beat THE BEAT of the Rowe AMI DIPLOMAT—it's got what it takes in the way of authentic Discotheque SOUND. It's not just a juke box, it was designed especially for Discotheque—to envelop the whole place with the sound of a LIVE BIG BAND."

When asked for "success story" particulars . . . Fred quoted a few operators at random. "From Seranton, 'A real money-maker, before Discotheque \$45 a week, now \$125 a week.' . . . from Salisbury Maryland, 'Unbelievable! It never stops—previous take \$35 a week, now up to \$95 a week.' . . . and another from Delaware, 'fabulous sound, trouble free, increased from \$12 a week to \$60 a week.'

NATIONAL COIN

Authorized Wurlitzer Distributor

Exporting to all parts of the world for a quarter of a century!

All Types Coin-Operated Equipment New and Used.

Completely Reconditioned

GOTTLIEB 5-BALL PIN GAMES
PHONOGRAPHS—all makes and models
KIDDIE RIDES • BOWLERS, etc.

Send for literature and price list

NATIONAL COIN MACHINE EXCH.

1411-13 Diversy, Chicago 14, Ill., U.S.A.

Phone: BUckingham 1-8211

CABLE: "NATCOINCO"—CHICAGO

Rosen Gains Bank Support For His Filmotheque Unit

PHILADELPHIA—With the completion of negotiations that will provide full banking accommodations for the newest coin machine entertainment facility, David Rosen announced this week that it's now "full steam ahead" for his Filmotheque-Discotheque, the movie-music machine that combines both the music machine and the motion picture machine into a single unit.

Indicative of the confidence and trust that the financial institutions have placed in Rosen, and with added confidence that this form of coin operated entertainment is fast becoming an integral part of the coin machine industry, Rosen announced that "banking accommodations have committed themselves to us to the availability of a \$10,000,000.00 line for the handling of Filmotheque-Discotheque."

With machine ready to roll off the assembly line at the new Rosen plant at 22nd and Master Streets here, with over 600 all color film subjects ready for immediate delivery, and now with complete banking accommodations, Rosen's leasing program is proceeding at a pace that "far exceeds our original expectations."

"Filmotheque-Discotheque," said Rosen, "is the only one in the new movie-music field that is making a leasing program available to the trade. The program, which is available only to the coin machine trade, is evidence of the faith and confidence we have in the future of the item. We are not concerned, as others, with deposits or side drafts. We are leasing machines now to operators with options to buy. And a similar leasing program will soon be made available to distributors."

With the mounting interest already shown in both the machine and the program, Rosen said that appointments of distributors will be made later. From all parts of the country, interested distributors have been either calling or coming to the Rosen plant to see for themselves the two-in-one combination Filmotheque-Discotheque machine.

"With the great enthusiasm already generated in the trade by Filmotheque-Discotheque," said Rosen, "we want to screen out all the possibilities within the coin machine field before making any distributorship appointments. Our doors are still open to all interested distributors to come here and to see and hear for themselves what Filmotheque-Discotheque has to offer in its present form, and to appreciate and understand its program and potentialities for the future."

MONROE COIN MACHINE EXCHANGE

24-23 PAYNE AVE. • CLEVELAND, OHIO • 216-781-4600

U. S. TRADE ASSOCIATIONS

(Local, Continued)

Amusement Machine Oprs. Assn.
2441 N. Charles St.
Baltimore 18, Md.
Pres. Irv Goldner

Kansas City Music Oprs. Assn.
2905 Southwest Blvd.
Kansas City 8, Mo.
Pres. John Masters

Maryland Vendors Assn.
3205 Elba Dr.
Baltimore, Md.
William McCarty

Music Operators Assn. of Mass.
209 Washington St., Suite 1001
Boston 8, Mass.

Western Mass. Music Guild
116 Race St.
Holyoke, Mass. 01040
Russel Mawdaley

Minnesota Amusement Games Assn., Inc.
601 Central Ave.
Faribault, Minn.

Missouri Coin Machine Council
704 E. Gregory Blvd.
Kansas City 31, Mo.
John H. Fling

Missouri Amusement Machine Assn.
705 Olive St., Rm. 1420
St. Louis, Mo.
Dewey S. Godfrey Jr.

MA of M&CMO
2605 Gene Field Road
St. Joseph, Mo.
Robert P. DeHart

Montana Music Guild
204 Fourth St., S.
Great Falls, Mont.
R. E. Holm

Coin Operated Industries of Neb.
1208 Farnan St.
Omaha, Neb.
Howard Ellis

Tri County Music Assn.
361 Columbia Ave.
Cliffside Park, N. J.

Amusement Assn. of South Jersey
210 Pavilion Ave. Riverside, N. J.
Joan A. Rossi

N. J. Council of Coin Machine Ops.
1175 Broad St.
Newark, N. J. 07114
D. W. Steinberg

Music Guild of Nebraska
201 South 13th St.
Omaha, Neb.
Pres. Frank Halys

N. J. Coin Machine Council
805 Hopkins Road
Haddonfield, N.J.
Pres. Bill Cannon

Vending Guild of N.J.
1175 Broad St.
Newark, N.J.
Pres. Allen Waldor

New Mexico Music Guild
P. O. Box 86
Las Cruces, N. M.
Alfred Harper

Music Oprs. of New York, Inc.
250 W. 57th St.
New York, N.Y.
Pres. Al Denver

New York State Operators Guild Inc.
P.O. Box 371
Beacon, N.Y.
Pres. Mike Mulqueen

New York State Coin Machine Assn.
Box 204
Hurleyville, N.Y.
Pres. Millie McCarthy

Westchester Oprs. Guild Inc.
116 N. Main St.
Port Chester, N.Y.
Pres. Carl Pavesi

GOTTLIEB'S DODGE CITY

4 PLAYER

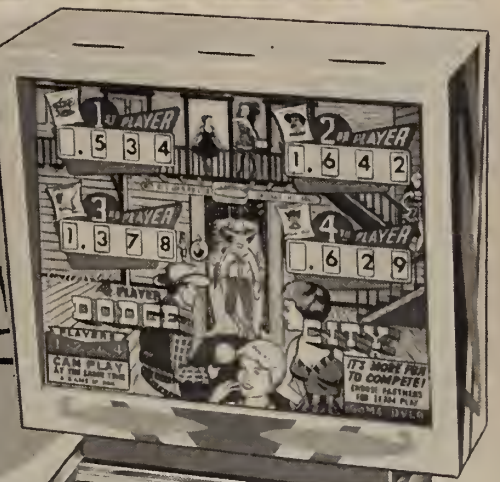
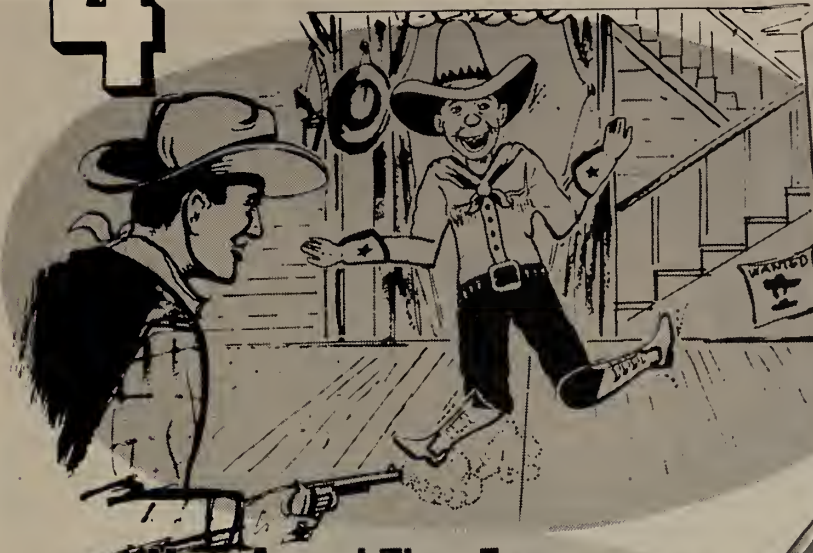

More Appeal Than Ever with
The Greatest Eye Catching
Animation Ever Created!

ONE COWBOY SHOOTS AT THE FEET OF
ANOTHER MAKING HIM DO THE MOST
COMICAL DANCE YOU'VE EVER SEEN.

FASCINATING SPINNING NUMBERS AND STAR
INDICATES VALUES OF 5 TWO-WAY ROLL-
UNDERS FOR SCORE AND SHOOT AGAIN FEATURE!

- Moving light A-B-C-D-E feature multiplies value of rollunders by 10 and 100.
- Alternating light kick-out holes score 5 to 150 points.
- New! Blinking sign tells when last ball is in play.
- New! "Pop-art" cabinet decoration makes machine stand out as "new" in all locations.
- 3 or 5 ball play ● Match feature



New "Hard-Cote" Finish
Extends Playboard Life
to an All-Time High!



Ask your distributor to
Show you the Dancing Cowboy.

D. Gottlieb & Co.

1140-50 N. Kostner Avenue • Chicago, Illinois 60651

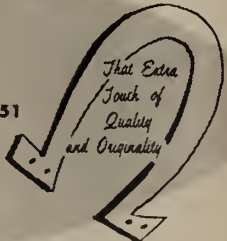

C. M. Ops Assoc. of N. Engl.
433 Main St.,
Holyoke, Mass.
Pres. Russell Mawdsley
Phonograph Merchants' Assn.

928 Leader Building
Cleveland 14, Ohio
Pres. Jack Cohen

N. Carolina Ops. Assn.
946 Fairground Ave.
Greensboro, N. C.
Fred Ayers

N. Dakota Music Ops. Assn.
471½ South Main St.
Akron 11, Ohio
Charles Marvin

Automatic Phonograph Owners Assn.
1011 Tri-State Bldg.
Cincinnati 2 (C.O.A.)

Tors Music
854 N. High St.
Columbus, Ohio
Richard Thompson

Tri-County Phonograph Operators Assn.
Canton Area
127 Tremont St., S.W.
Massillon, Ohio
Edward Elum

Phonograph Merchants Assn.
928 Leader Bldg.
Cleveland 14, Ohio
Virginia Holcomb

Northwestern Ohio Music Ops., Inc.
511 S. Canal St.
Delphos, Ohio
Wm. E. Hullinger

Oregon Music Operators Assn.
1226 Southwest 16th Ave.
Portland 5, Ore.

Lehigh Valley Amuse. Mch. Oprs. Assn.
240 N. 9th St.
Allentown, Pa.
R. D. Owens

Eastern Pennsylvania Amusement Machine
Assoc.
10 East Main St.
Norristown, Pa.
Pres. J. J. Smith, Jr.

Amuse. Mchs. Assn. of Philadelphia
685 N. Broad St.
Philadelphia, Pa.
Bus. Mgr. Jos. Silverman

Northeastern Pennsylvania Music & Machine
Operators Assoc.
P.O. Box #348
Scranton, Pa.
Pres. Ben Sterling

So. Carolina Coin Ops Assoc.
1309 Taylor St.,
Columbia, S.C.
Mgr. Ashby Bradford

South Dakota Phonograph Operators Assn.
125 N. Monroe St.
Pierre, S.D.
Pres. Gordon Stout

Music & Vending Assoc. of S.D.
Lead, South Dakota
Pres. John Trucano

Music Operators of Virginia
2001 W. Main St.
Richmond 20, Va.
Pres. Gilbert Bailey

West Virginia Music & Vending Assn.
1301 Winchester Ave.,
Martinsburg, W.Va.
Pres. Dilman DeHaven

Wisconsin Phonograph Operators
115 Smythe St.
Beaver Dam, Wisc.
Pres. C. S. Pierce

Milwaukee Coin Machine Assoc.
6100 W. Bluemound Rd.
Milwaukee 13, Wisc.
Pres. Sam Hastings

MANUFACTURERS NEW EQUIPMENT

CURRENTLY IN PRODUCTION

Prices shown are list prices f.o.b. factory. Manufacturers have not authorized prices where no price is shown

ALL-TECH INDUSTRIES

- Gold Crest 6 (46"x78")
- Gold Crest 7 (52"x92")
- Gold Crest 8 (57"x101")
- Gold Crest 9 (64"x114")

AMERICAN SHUFFLEBOARD CORP.

- Electra "6" (6' 6-pkt. table)
- Electra "7" (7' 6-pkt. table)
- Electra "8" (8' 6-pkt. table)
- Classic "6" (6' 6-pkt. table)
- Classic "7" (7' 6-pkt. table)
- Classic "8" (8' 6-pkt. table)
- Imperial Shuffleboard (16' to 22')
- Imperial Cushion Model (12')
- Bank Shot Model (8')

AUTOMATENBAU FOERSTER

- Natl. Sales Agents, L. T. Patterson, Distribs.
- Football Match
- Europa Meister Eishockey
- Musikbar 100
- Billiard Tables Miniature

AUTOMATIC PRODUCTS CO.

- CIGARETTE VENDORS**
- Smokeshop "Starlite 450"; 18 sel., cap. 450
- Smokeshop "Starlite 630"; 18 sel., cap. 630
- Smokeshop "Starlite 850"; 27 sel., cap. 850
- CANDY VENDOR**
- Candyshop "100" Ten Columns, 400 Capacity
- Candy; Six Columns, 200 Capacity—Gum & Mint. First-In, First-Out Feature; Multiple Pricing, Changermaker, Optional.

AUTO-PHOTO CO.

- Model 12 Studio \$3,245.00

BALLY MFG. CO.

- 1965 Bally Bowler (5/65)
- Band Wagon 4P (5/65)
- Sheba 2P (3/65)
- Border Beauty (Bingo) (2/65)
- All The Way Shuffle 2P (10/65)
- Bucky Bronco Kiddie Horse \$ 995.00
- Bullfight 1P (1/65)
- Magic Circle 1P (6/65)
- 50/50 2P (8/65)
- Beauty Beach Bingo (8/65)

BATES INDUSTRIES

- Round Pool Table

T. H. BERGMAN CO.

- Nat'l Sales Agents, Duncan Sales Co.
- Arizona Gun (Live action pellets)

CAMECA

- Scopitone-Audio-Visual Machine. 36-Sel. 26 inch screen. Nat'l Sales Agents, Scopitone, Inc., USA.

COAN MFG. CO.

- CIGARETTE VENDORS**
- Model 74-MD; 74 sel., cap. 74
- Model 74-APC; 74 sel., cap. 74
- Model 94-UM; 94 sel., cap. 94
- Model 94-UC; 94 sel., cap. 94
- Model 116-WM; 116 sel., cap. 116
- Model 116-WC; 116 sel., cap. 116
- CANDY VENDORS**
- Model 74-APD; 74 sel., cap. 74
- Model 84-UD; 94 sel., cap. 94
- Model 116-WD; 116 sel., cap. 116
- Model 188-D, 188 sel., cap. 188
- Model 47-Pastry, 47 sel., cap. 47

CHICAGO COIN MACHINE

- Gold Star Shuffle (7/65)
- Big League Baseball 2P (4/65)
- Top Brass Shuffle (4/65)
- Super-Sonic Bowler (3/65)
- Pop-Up 1P (10/64)
- Mustang Pin 2P

DuKANE CORP.

- Ski 'n Skore
- Write for Dist. Information

FISCHER MFG. CO., INC.

- COIN**
- Empress 101 (101")
- Empress 92 (92")
- Regent 91 (91")
- Regent 77 (77")
- Fiesta 58

- NON COIN**
- Empire VIII (4x8)
- Empire VII (3½x7)
- Duchess VIII (4x8)
- Duchess VII (3½x7)
- (Fiesta-Styled Models.)
- Crown Town & Country
- Town & Country
- Princess 58

J. F. FRANTZ MFG. CO.

- Little Leaguer (12/62)
- Double Header (12/62)
- Save Our Business
- U.S. Marshall 5½ Gun
- Kicker & Catcher
- ABT Challenge Pistol
- ABT Guesser Scale
- ABT Rifle Sport
- Aristo Scale

GOLD MEDAL PRODUCTS

- Popcorn Vendor

D. GOTTlieb CO.

- Dodge City 4P (7/65)

GREAT LAKES EQUIPMENT

- Elliptipool (elliptical pool table) ..

PAUL W. HAWKINS MFG.

- Rodeo Pony \$ 845.00
- Mustang 695.00
- Pony Cart 610.00
- Ben Hur Chariot 595.00
- Twin Quarterhorse 575.00
- Derby Pony Jr. 550.00
- Leo The Lion 550.00
- Sam The Clown 495.00
- Donny Duck 475.00

IRVING KAYE CO., INC.

- NON-COIN MODELS**
- Deluxe Continental (4½"x9')
- Ambassador 70 (85"x47")
- Ambassador 75 (92"x52")
- Ambassador 80 (106"x58")
- Ambassador 90 (114"x64")

COIN-OP MODELS

- Deluxe Eldorado 6 Pkt. Series
- Mark I, 77x45
- Mark II, 85x47
- Mark III, 92x52
- Mark IV, 106x58
- Mark V, 113x63
- Deluxe Satellite, 77x45
- Deluxe Klub Pool
- Regular 56x40
- Jumbo 75x48
- El Dorado Shuffleboard
- Ring-O Round
- Pool Table (56" diameter)

MARVEL MFG. CO.

- Side-Rail Elect. Scoreboard
- Coin Box

MIDWAY MFG. CO.

- Play Ball 1P (Replay Model Available)
- Flying Turns 2P (9/64)
- Rifle Champ 2P (1/65)
- Mystery Score (8/65) (Novelty Game)

NATIONAL VENDORS, INC.

- CIGARETTE VENDORS**
- Series 113; 13 8-column shifts, cap. 447
- Upright-Series 113; 13 8-col. sbifts, cap. 447
- Crown series 222; 22 sel., cap. 616
- Crown series 800; 20 sel., cap. 850
- Consolette-Series 650; 20 sel., cap. 670
- Moduline-22M; 22 sel., cap. 616
- Moduline-80M; 20 sel., cap. 850

ORBIT ENGINEERING CORP.

- Pitching Horseshoes (4/65)
- Tic Tac Toe (4/65)
- Dice Games

PROTOCISION ENGINEERING, INC.

- V-Shape Shuffle

PUTT-WELL GOLF CORP.

- 9-Hole Golf Game (2/65)

REDD DISTRIBUTING CO.

- Cinch Instant Shine Vendor
- (Vendor and packaged Cinch product)
- Giopen Coffee Vendor (Natl. Agents)
- Vend-A-Book Comic Book Vendor

ROCK-OLA MFG. CO.

- Caravelle (20 Col. 800 Packs) Model 3002
- Cigarette Machine
- Model 424 Princess Royal (7" LP Del.) St.-Mon.
- Model 426 160-Sel. (Grand Prix II) 45-33 RPM St.-Mon.
- Model 429 100-Sel. (Starlet) 45-33 RPM St.-Mon.
- Model 403 100-Sel. Wall Phono (33 1/3 Optional).
- 1628 Deluxe "Stereo Twins" Speakers
- 1629 "Stereo Twins Jr" Speakers
- 1950 Remote Volume Control Unit
- Model 500 160-Sel. Stereo Speaker Wallbox
- 3 level personal-pushbutton volume control
- Model 501 100-Sel. Wallbox
- 1578 160-Sel. Wallbox
- 1584 100-Sel. Wallbox
- 1551 Universal Wall Box Bar Bracket
- 1981 Money Counter for Model 425, 418-SA, & 414
- Model TRLB-M—Coffee, Hot Chocolate, Soup Vendor—Batch fresh brew, modulator door and light, 600 cup capacity, coffee 4 ways, extra cream and sugar, whipped powdered chocolate, liquid sugar, liquid soup, fresh cream, with changer. Everpure filter.
- Model 3402—Coffee, Hot Chocolate, Soup and Tea—(Compact Model). Single cup, fresh brew, serves coffee and tea 4 ways.
- Model 3403—as above, without 4 way tea feature.
- Model 1404-S, single cup, fresh brew coffee & hot drink vendor. "Ever-Pure" water filtering system. Serves coffee 4 ways, 450 cup capacity, extra cream & sugar. Ict whipped chocolate & hot soup.

DAVID ROSEN, INC.

- Filmtheque-Diskotheque
- Phono-Voice

ROUND O'POOL

- Elliptical table (48"x52").

ROWE AC SERVICES

- Rowe—AMI N-200 Phono (Diplomat) 33-45 RPM St.-Mon. Convertible to 200, 160 and 100 selections.
- HAC-200 Hideaway, 200 Sel. Mon.
- HAB-200 Hideaway, 200 Sel. Selective Stereo
- CFA Stepper, CFD Stepper, WQ-100 100 Sel. W.B., WQ-100 100 Sel. W.B., WQ-120 120 Sel. W.B., WQ-200 200 Sel. W.B., WQ-200-1 200 Sel. W.B., Dual Price Play, WQ-200-3 200 Sel. W.B., Dual Price Play, 4-coin Relector.
- F-10436 Bar Grip, W. B. Mounting Bracket.
- EX-600 Cylindrical Wall Speaker.

EX-700 Wall Speaker.

- L-2130 Ceiling Spkr., Choice of Grille.
- Types Listed: L-2136 Random Pattern, L-2136 Uniform Pattern, L-2605 Circular Flush-Mount Grille.
- Rivera Cigarette, 20 sel 800 pack.
- Celebrity Cigarette Merchandiser, 14 selection, 510 pack capacity, modular line.
- Ambassador Cig. Vendor 286; 14 sel., cap. 510.
- Celebrity Cig. Vendor 260; 20 sel., cap. 800.
- Celebrity Candy Merchandiser, 11 selections, 360 capacity, modular.
- 77 Candy Merchandiser, 11 sel., 360 cap.
- Tasty 20 Candy Merchandiser, 20 sel., 560 cap.
- Celebrity Pastry Merchandiser, 5 selection, 100 capacity, modular.
- Celebrity Hot Food Merchandiser, 7 selection, 140 capacity, modular.
- Celebrity All Purpose Merchandiser, 130 capacity, 130 selection, modular.
- Celebrity Fresh Brew Coffee Merchandiser, 11 selection, 750 cup capacity, modular.
- Celebrity Cold Drink Merchandiser, 4 selection, 1000 cup capacity, crushed ice feature optional, modular.

THE SEEBURG CORP.

PHONOGRAPHS

- LPC-480 & LPC-480R (Remote Control) stereo LP Console—160 Selections (Up to 480 Selections with all album programming). Spotlitged Album Award. 3-way audio. Income totalizer. Personalized panel. Plays 33-1/3 and 45 RPM records intermixed, stereo or monaural. Album and Universal Pricing, Half Dollar. Transistorized and unitized "pull out" components. Test point front servicing Blue or tangerine speaker grilles.

- HLPC-1—Stereo LP Hideaway. 160 selections (Up to 480 selections with all album programming). Income Totalizer. Plays 33-1/3 and 45 RPM records intermixed. Album and universal pricing.

- SC-1—Stereo Consolette. 160 selections. Used for remote selection of any record on LP Console or Hideaway. Personalized panel. Album display panel. Album pricing. Push-button volume control. Twin stereo speakers. Remote Income Totalizer. Polished chrome or copper finish.

- EBCS-1—Extended Bass Consolette Speaker. Provides full range stereo response in conjunction with Consolette speakers.

- SC-11—Stereo Communication Consolette. Consolette serves as Intercom.

- CM-1—Consolette Intercom Master Unit. Used with Stereo Communication Consolette.

BACKGROUND MUSIC

- ICK-1—Intercommunication Consolette Kit. Converts Stereo Consolette to Stereo Communication Consolette.

- BMS-2—Background Music System 1000 Selections.

- BMC-1—Background Music Compact, 1,000 Selections.

- BMCA-1—Background Music Companion Audio. Used with Background Music Compact (BMC-1)

- MPE-1—Electronic Memory Programmer. Used with the Background Music Compact (BMC-1) to insert special announcements and commercials into the background music program.

- SABMC-1—Seeburg Automatic Background Music Center. For use with FM Multiplex Telephone Lines and On-Premise Locations. Total of 112½ hours of music.

- SEP-1—Seeburg Encore Phonograph. 760 Selections of Foreground Music

CANDY VENDORS

- W10CN1—Mechanical. 10 Selections. 220 bar capacity.

- W8TIG—Mechanical 8 Selections. 152 bar capacity.

- CIGAR VENDOR
- W6CRI—Mechanical. 6 Selections. 114 package capacity.

CIGARETTE VENDORS

- 4E5—Electric. 22 Selections. 825 pack capacity.

- W20T1—Mechanical. 20 Selections. 672 pack capacity.

- W14T1—Mechanical. 14 Selections. 510 pack capacity

- MCC-20—Mechanical. 20 Selections. 720 pack capacity.

CIGARILLO VENDOR

- W8C01—Mechanical. 8 Selections. 200 Package Capacity.

COFFEE VENDORS

- MC4—Marquee Coffee Vendor, 5, 6 or 7 Selections. Brews fresh ground coffee one cup at a time. Hot coffee, hot chocolate, hot soup and hot tea. 605 cup capacity. Income Totalizing System.

- 764—Modular Coffee Vendor, 5 or 6 selections. Brews fresh ground coffee one cup at a time. Hot coffee, hot chocolate, hot soup and hot tea. 650 cup capacity. Income Totalizing System

- W5C4D—Williamsburg Fresh Brew Coffee Vendor. 5 Selections. Brews one cup at a time. Hot coffee and hot chocolate. 428 cup capacity. Income Totalizing System.

- W6HB1—Williamsburg Coffee Vendor. 6 Selections. Soluble hot coffee, hot chocolate and hot soup. 500 cup capacity.

- 772—Marquette Coffee Vendor. 5 selections. Brews fresh ground coffee one cup at a time. Hot coffee and hot chocolate. 320 cup capacity.

COLD DRINK VENDORS

- MS4—Marquee Cold Drink Vendor. 4 or 7 selections with or without crushed ice. Carbonated and non-carbonated flavors. 7-selection model offers 2 selections of iced tea. 1,500 cup capacity. Income totalizing System.

- S94—Modular Cold Drink Vendor. 4 or 7 selections with or without crushed ice. Carbonated and non-carbonated flavors. 7-selection model offers 2 selections of iced tea. 1,500 cup capacity. Income Totalizing System

GOLD CANNED DRINK VENDOR

- W3CV1—Williamsburg Cold Canned Drink Vendor. 3 selections. 189 can capacity. Automatic Can Opener.

GENERAL MERCHANDISE VENDOR

- 15G1—Pick-A-Pac 15 Selections. 315 item capacity.

LAUNDRY SUPPLY VENDOR

- W8L1—Mechanical. 8 selections. 152 item capacity.

MILK VENDOR

- MV-2—Modulra Milk Vendor. 3 selections 360 carton capacity.

PASTRY VENDORS

- W6P1—Mechanical. 6 selections. 72 package capacity.
- W6P2—Mechanical. 6 selections. 114 package capacity.

SHIPMAN MFG. CO.

- CIGARETTE VENDORS**
- Mark II: 13 or 17 columns.

SOUTHLAND ENGINEERING, INC.

- Kiddie Railroad

TEE-Q RESEARCH & MFG. CO.

- Thunderbird Raceways\$ 595.00

UNIQUE INDUSTRIES

- Stone Age Rock-it
- Armored Tank (convertible top) ..
- Air Force Jeep

URBAN INDUSTRIES, INC.

- Movie Theaters
- Model AP-10
- Model AP-10 Console
- Model AD-Panoram
- Model KKT-Kiddie Cartoon theater

U.S. BILLIARDS INC.

- 6 Pkt. Series:
- Pro 1—78x46
- Pro 2—88x51
- Pro 3—93x53
- Pro 4—103x58
- Pro 5—114x64
- Club Pool
- 56x40
- 75x43

VALLEY SALES CO.

- Bumper Pool®
- Model 522S/W Reg. Size
- Model 735A—78x45
- Model 875A—88x50
- Model 935A—93x53
- Model 1035—100x57
- El Magnifico Series
- Model 884—88x50
- Model 934—93x53
- Model 1014—101x57

THE VENDO CORP.

- CIGARETTE VENDORS**
- CA1A Console; 22 sel., cap. 850
- C-23; 15 sel., cap. 520
- 429-Special; 11 sel., cap. 428
- Continental "30"; 30 sel., cap. 830
- Tobacco Shoppe "30"; 30 sel., cap. 830

WESTINGHOUSE ELECTRIC CO.

- 6-Selection CupDrink Vendor
- Fresh Brew Coffee Vendor
- Candy Vendor
- Cigarette Vendor

WILLIAMS MFG. CO.

- Pot-O-Gold 2P
- Oasis Bowler (6/65)
- Bowl-A-Rama (7/3)
- Pyramid Shuffle (6/65)

THE WURLITZER COMPANY

- 2900-1 200 Selection
- 2900-3 200 Selection with Top Tunes Golden Bar
- 2900-4 200 Selection with Little L.P.
- 2900-7 200 Selection with Top Tunes Golden Bar and L.L.P.
- 2910-1 100 Selection
- 2910-3 100 Selection with Top Tunes Golden Bar
- 2910-4 100 Selection with Little L.P.
- 2910-7 100 Selection with Top Tunes Golden Bar and L.L.P.
- Hideaway Phonographs
- 2917-4 200 Selection with Little L.P.
- 2917-7 200 Selection with Top Tunes and Little L.P.
- 2911-4 100 Selection with Little L.P.
- 2911-7 100 Selection with Top Tunes and Little L.P.
- Remote Control Equipment
- 5220 Wall Box 200 Selection-10¢-25¢-50¢ with Speakers, Top Tunes Golden Bar and L.L.P.
- 5220A Wall Box 200 Selection-10¢-25¢-50¢ with L.L.P.
- 5225 Wall Box 100 Selection-10¢-25¢-50¢ with Speakers, Top Tunes Golden Bar and L.L.P.
- 5225A Wall Box 100 Selection-10¢-25¢-50¢ with L.L.P.
- 5010 Wall Box Ten Top Tunes—50¢ Coin Only
- 259B Stepper, 200 Selection for Model 2910
- 261B Stepper, 200 Selection for Model 2900
- 5121 Speaker—Private—Wurlitzer Wall Box Mounting
- 5121A Speaker—Private—Wall Mounting
- 5123 Speaker—Wall 12" Coaxial
- 5125B Speaker—Extender (Packed in Pairs)
- 5126 Speaker—Directional (Packed in Pairs)

the Diplomat

MUSICONSOLE

by ROWE® AMI



THE REASON THE DIPLOMAT MAKES FRIENDS SO READILY is easily seen. Its smart, distinctive, go-everywhere styling enhances the most discriminating location. Just look at the distinctive grille panel, the dramatic full-width backlighted location panel, the attention-getting album display panel, the intriguing star-pattern color wheel.

The Diplomat gives you everything you want for increased play and profits. Big selection keys. Easy-to-read, easy-to-select titles. Room-filling, self-contained Stereo Round.* Versatile programming that lets you switch, on the spot, to 200, 160 or 100 selections. It's designed to play and play and play with a minimum of fuss and servicing, but when you want to take a look at it, access was never easier.

Here's just what you need to make better friends in your present locations, make new friends in new locations. See it. Hear it. Put it to work making friends—and profits.

Rowe

AC
MANUFACTURING
Troy Hills Road
Whippany, New Jersey

CLASSIFIED ADVERTISING SECTION

CLASSIFIED AD RATE 20 CENTS PER WORD

Count every word including all words in firm name. Numbers in address count as one word. Minimum ad accepted \$5.00. CASH OR CHECK MUST ACCOMPANY ALL ORDERS FOR CLASSIFIED ADVERTISING. If cash or check is not enclosed with order your classified ad will be held for following issue pending receipt of your check or cash.

NOTICE—\$67 Classified Advertisers. Outside USA add \$52 to your present subscription price. You are entitled to a classified ad of 40 words in each week's issue for a period of One Full Year, 52 consecutive weeks. You are allowed to change your Classified Ad each week if you so desire. All words over 40 will be billed at the rate of 20c per word. Please count words carefully. Be sure your Classified Ad is sent to reach New York publication office by Wednesday, 12 Noon, of preceding week to appear in the following week's issue.

Classified Ads Close WEDNESDAY

Send all copy to: CASH BOX, 1780 Broadway, New York 19, N.Y.

WANT

SAMPLE D.J.'s FOR PROMOTION: WE PROMOTE all types of records—Pop, R&B, Spirituals, etc. Send your latest releases for Honest Evaluation. We don't promote Garbage, Good or Bad, Immediate Reply Assured. NEW ENGLAND RECORD PROMOTIONS, 106 NORTHAMPTON ST., BOSTON, MASS. 02118.

L.P.'s, CUTOUTS, OVERSTOCKS, CLOSEOUTS, SURPLUS ANY LABELS. For premiums and giveaways. New merchandise only. We pay cash. Small or large lots. EMPIRE DISTRIBUTING CO., 4610 LIBERTY AVE., PITTSBURGH 24, PA. (Tel. (412) 682-8437).

WANT TO BUY—MILLS PANORAMS AND A.M.I. MUSIC BOXES, models H-I-J-K 120 and 200 selections. Also A.M.I. WQ200 WALLBOXES with accumulators. PLEASE QUOTE QUANTITY AVAILABLE, CONDITION AND PRICE. CLEVELAND COIN INTERNATIONAL, 2029 PROSPECT AVENUE, CLEVELAND, OHIO, TO.1-6715.

FOR RESALE: SEEBURG AND WURLITZER Phonographs, Games. Send inventory and lowest cash prices. HASTINGS DIST. CO., INC.—6100 WEST BLUEMOUND ROAD—MILWAUKEE 13, WISC.

BINGOS, MISS AMERICA, ROLLER DERBY, Circus Queen, Arcade Equipment, Rock-Ola, Seeburg and Wurlitzer 1962/1963, Baleringa, County Fair, Laguna Beach, Acapulco, Cancun, Bikini, Lido, Goldengate, Silver Sails, Bounty—needed by IMPORT-EXPORT MARCEL GROSCH 3 BLD. AVROY, LIEGE, BELGIUM.

USED 45 RPM RECORDS, ALL TYPES AS they run, right off the route. No sorting or picking. We pay freight from anywhere in U.S.A. Standing order available for regular shippers. JALEN AMUSEMENT CO. 1215 S. HOWARD STREET—BALTIMORE, MD. 21230.

PANORAMS AND PANORAM PARTS. United Triple Plays wanted. ADVANCE AUTOMATIC SALES CO., 1350 HOWARD ST., SAN FRANCISCO, CALIF. (Tel. HEmlock 1-1750)

WE PAY THE HIGHEST PRICES FOR ALL BALLY BINGOS and Gottlieb Pinballs manufactured 1958 and up. Interested all brand new closeouts. Also arcade equipment. Cable or write to: HOLLAND-BELGIE, EUROPE SPRI., 276 AVENUE LOUISE, BRUSSELS & BELGIUM. (Cable address.) HOBEL-EUROPE-BRUSSELS.

RECORDS, 45's AND LP's, SURPLUS, RETURNS, overstock, cut-outs, etc. HARRY WARRINER, KNICKERBOCKER MUSIC CO. —453 McLEAN AVE., YONKERS, N.Y. (Tel. GRenleaf 6-7778).

WE PAY CASH AS ALWAYS FOR: SEEBURG; Wurlitzer; AMI and Rock-Ola music; Gottlieb Pins; Arcade equipment; Bally Bngos; Write or cable: PALMER AT BELINTRACO —31 SOMERSTRAAT—ANTWERP 1, BELGIUM.

SELL YOUR SURPLUS 45's TO THE NATION'S largest user. We are the nation's foremost packager of promotionally priced record packs. We purchase unlimited quantities on a steady basis. Wire—phone for quick deal. NATIONAL BAG-O-TUNES INC., 3318 DELAVALLE AVE., BRONX, N.Y. 10469. (Tel. TU 9-9302).

NEW 45 RPM RECORDS, NO QUANTITY too large or small. We pay the highest price, plus all freight. Also over-run return hit records. Contact immediately for quick transaction. We pay cash. SUTTON RECORD CO.—26 West 20th ST.—New York. N.Y. (Tel. CH 2-3250).

USED 45 RPM RECORDS. WE PAY freight & top prices. KING SALES—1415 WASHINGTON STREET—BOSTON, MASS.

45 RPM RECORDS, NEW OR USED. NO quantity too large or small. Highest prices paid. Write stating quantity on hand. TONY GALGANO DIST. CO., 4135 W. ARMITAGE, CHICAGO 39, ILL. (Tel. DICKens 2-7060).

USED RHYTHM AND BLUES 45's. WE PAY top prices plus freight. Write first, stating approximate amount on hand. Blues and rhythm and blues only, please. RECORD MART, 2222 ELM, DALLAS, TEXAS 75201. Phone RIVERSide 8-2053.

WE WANT TO BUY: WILLIAMS CRANES, Chicago-Coin Steam Shovels. Cash. TRI STATE TRADING CO., BOX 272, MILES CITY, MONTANA.

EXPERIENCED GAMES AND MUSIC REPAIR man. Fringes, permanent, duplicating salary. VALLEY VENDORS CORP., 1145 W. HILTON, PHOENIX, ARIZ. 258-8581.

WANTED—NEW COIN MACHINE PARTS, surplus relays, coils, steppers, motors, counters, etc. ECONOMY SUPPLY CO., 577 TENTH AVE., NYC.

WANT-NEW OR USED 45 R.P.M. SINGLES not over 6 months old. We pay 11¢ each and the freight and we can use 200 of a number. PH. 312-766-3638. SKYLINE RECORDS, 1117 BROOKWOOD AVE., BENESVILLE, ILL. 60106.

WANTED WILLIAMS 57 BASEBALL AND Chicago Coin Champion Rifle Range. TRENT BROS. MUSIC CO., 708 N. SCALES ST. REIDSVILLE, N.C., P.O. Box 1044.

BEAR GUNS & COON HUNTS IN WORKING order, Capitol Drivemobiles, Baseballs, Guns, Arcade Equipment, 3WT Wallboxes, State model, Condition, Make and best Cash Price. NEW WAY SALES, 1257 QUEEN STREET WEST, TORONTO, CANADA.

"SPECIAL 15 BRAND NEW BUMPER POOL with slate only \$150 each. 15 beautiful Wurlitzer 2810-3 @ \$695—25 new Giepen 100 Coffee Machines \$65—Wanted in Trade Shuffle Alleys." REDD DISTRIBUTING COMPANY, INC., 80 COOLIDGE HILL RD., WATERTOWN, MASS. Phone (area code 617) 926-2250.

SEEBURG VL200, L100, 2225, LPC; Wurlitzer 1900, 2104, 2250, 2400S; Rock-Ola 1448, 1493; Ami all models from 1957; Recent Pingames, Gottlieb, Williams; Uprights Keeney, Bally, etc.; Bngos, Close outs; Rush offers: VICTOR HUGO, KON. ASTRIDLAAN 49 MECHELEN, BELGIUM.

WANT FOOSBALLS. GERMAN-MADE, NEW or used. Quote price. BUDGE WRIGHT'S WESTERN DISTRIBUTORS, 1226 SW 16TH AVE., PORTLAND, ORE. 97205.

WANT—VALLEY POOLS 85x47 SIZES. TOLEDO COIN MACHINE EXCHANGE, 814 SUMMIT STREET, TOLEDO, OHIO. (Tel. CH 3-7191)

TELEQUIZ ARE WANTED, WRITE TO THE General Automatic S.C., T.G.A. 60, rue Van Schoor, Brussels, 3, Belgium.

WANT—BASEBALLS, POOL TABLES, Shuffleboard Scoring Units, Shuffleboards with anti-cheats, Guns, Bear Guns, Coon Hunts, Arcade Equipment, Personal Music. Write stating make, model, condition and best cash price. ST. THOMAS COIN SALES, 669 TALBOT ST., ST. THOMAS, ONTARIO, CANADA. Area 519-631-9550.

FOR SALE

ACE LOCKS KEYS LIKE SEND LOCKS AND the key you want them mastered to. \$1.00 each less 10% lots of 50 or more. 24 hour service. RANDEL LOCK SERVICE, 61 ROCKAWAY AVENUE, VALLEY STREAM, N.Y. 11580. TEL: 516-VA5-6216.

PIN GAMES \$75.00 UP. SHUFFLE ALLEYS \$50.00 UP. MCG20 Dugrenier—Like new \$325.00, E-2's 4 for \$500.00, Stoner D-500 Coffee \$75.00, DS160's \$775.00, AY \$675.00, Y100M \$600.00, AQ \$595.00, 222's \$495.00, CALL G. K. GABRIELSON & CO., INC., 724 MEMORIAL DRIVE, S. E., ATLANTA 16, GEORGIA, JA. 5-7441.

BALLY: ALL STAR SUPER BOWLER \$75, ALL The Way Shuffle \$695, Skill Score \$95, Big Inning Baseball \$75, Fun Phone \$95, Spinner \$50, Table Hockey \$95, Williams Official Baseball \$145, Midway Shooting Gallery \$85, Voice-O-Graph (late) \$395, Pra Golfer \$295, Val-O-Matic Card Vender \$85. All equipment clean and ready for location. Also large selection of used music and vending machines. Direct overseas shipment from Part of Detroit. MARTIN AND SNYDER COMPANY, 13200 W. WARREN AVENUE, DEARBORN, MICHIGAN, TEL. LUzon 2-2300.

EXPORT SPECIAL LIST: BASEBALLS, GUNS, Shuffle Alleys, Pin Balls. All Bingo machines. Write For Prices. D. & P. MUSIC, 27 E. PHILADELPHIA STREET, YORK, PA. Phone 848-1846.

WE HAVE A CHOICE SELECTION OF LATE Williams Two Players. Write for prices MIDWEST DIST., 709 LINWOOD BLVD.—KANSAS CITY, MO.

WURLITZER 2000 @ \$240.00, WURLITZER 2150 @ \$275.00, Wurlitzer 2200 @ \$425.00, Wurlitzer 2300 @ \$495.00, Wurlitzer 2400 @ \$595.00, Wurlitzer 2500 @ \$645.00. Northwest Sales Co. of Oregon, 1040 S. W. 2nd Ave., Portland, Oregon 97204. Phone 228-6557.

BINGO SALE ON SHOPPED BOUNTYS: SILVER Sails: Golden Gates: Lidos: Can Cans: Laguna Beaches: County Fairs: Lowest Prices in town. Packed expertly for export. Call or write NASTASI DISTRIBUTING COMPANY, 826 BARONNE STREET, NEW ORLEANS, LOUISIANA, (523-6386, 523-1471) quickly.

GOTTLIEB, CORRAL \$210, SLICK CHICK \$205, Sunset \$225, Melody Lane \$210, Liberty Bell \$285, Showboat \$215, Olympic \$205, Oklahoma \$265, Lancer \$310, Dancing Doll \$165, Big Casino \$230, Seven Seas \$185, Aloha \$165, UNITED NOVELTY CO. BILOXI, MISS. 436-4328.

GOTTLIEB—CLEANED, MECHANICALLY COMPLETELY RECONDITIONED, Off our own routes—2 Player—Around World, Atlas, Capt. Kidd, Double Action, Gondolier, Lite Card, Made-moiselle, Melody Lane, Race Time, 7 Seas, Whirlwind, 4 Player—Texan. Single Player—Kewpie Doll, Miss Annabelle, Roto Pool. All of the above are available at \$75.00 each. STAN HARRIS & CO., 508 W. VENANGO ST., PHILA., PA.

BARGAINS: COMPLETELY RECONDITIONED: Bally Star Jet (2 pl.) \$275; Bus Stop (2 pl.) \$395; Sheba (2 pl.) \$445; Official Jumbo Shuffle 8 1/2' \$145; Lucky Shuffle 8 1/2' \$145; Lucky Alley 14' \$145; Trophy Bowler 14' \$125; Gottlieb Gigi \$245; Sunset (2 pl.) \$265; United Big Bonus Shuffle Alley 8 1/2' \$145; Sunny Shuffle 8 1/2' \$145; Line Up Shuffle 8 1/2' \$145; Chicago Coin Six Game Bowler 8' \$145; Wurlitzer 2810 (like new) \$695; 2410-S \$395; Rock-Ola 1448 \$195; 1468 \$295; Seeburg 161 (160 Sel.) \$495; MICKEY ANDERSON AMUSEMENT COMPANY, 314 EAST 11TH STREET, ERIE, PA. Phone. 452-3207.

FOR SALE: RECONDITIONED SHUFFLEBOARDS with scoring units and refinished tops or let us refinish your shuffleboards. We are interested in buying late Gottlieb Games. WALLACE DISTRIBUTING COMPANY, BOX 75, MINERAL WELLS, TEXAS, FA-5-3600.

ATTENTION OPS! GET LOWDOWN PRICES on all billiard supplies coin machine parts, accessories, etc. DIAMOND COIN MACHINE EXCHANGE, 609 WOODS AVE., NORFOLK, VIRGINIA. (Tel. 625-1716).

ATTENTION OF IMPORTERS — APPROXIMATELY 150 late model AMI's available during the months of July, August and September. These models consist of Continental 11-200, JAL's, JEL's (B) and Tropicana—an exceptionally clean lot. Write if interested. TRIMOUNT AUTOMATIC SALES CO., 40 WALTHAM STREET, BOSTON, MASSACHUSETTS 02118.

HI-SPEED SUPER FAST SHUFFLE BOARD Wax. 24 one-pound cans per case. \$8.50 f.o.b. Dallas, Texas. Sold on money back guarantee. Distributor for D. Gottlieb, ChiCoin. STATE MUSIC DISTRIBUTORS INC., 3100 MAIN ST., DALLAS, TEXAS.

50 RECORDED SONGS ONLY \$3.00. MANY great songs by favorite artists, our choice. New records, guaranteed. State style of music preferred—Pop, R & B or Country. Offer good only in U.S.A. No C.O.D.'s. RHYTHM RECORDS—BOX A—ARCADIA, CALIF.

ATTENTION! WE ARE THE TRADE'S LARGEST suppliers of Pool Table supplies—slates, cues, balls, cloth, etc. Best quality, lowest prices, write or phone for our new catalog. EASTERN NOVELTY DISTRIBUTORS, 3726 TONNELE AVE., NORTH BERGEN, N. J. (Tel. UNion 3-8627).

SHUFFLE ALLEYS: UNITED SUPER BONUS \$95; Keeney Deluxe Challenge \$95; United Top Notch \$129; Ball Bowlers: Twin Bowler \$275; T.V. Bowler \$150; Classic Bowler \$150; Strike Bowler \$95; All of the above mentioned machines have been completely shopped and refinished. TRI-STATE DIST CO.—CALLIER SPRING ROAD—P.O. BOX 615—ROME, GA. (Tel. 234-7123. Area code 404).

SOUTHLAND ENGINEERING'S NEW IMPROVED model "Time Trials" in original cartons \$495. IMPERIAL COIN MACHINE EXCHANGE INC.—498 ANDERSON AVENUE, CLIFFSIDE PARK, N.J.

KLOPP COIN COUNTERS WE MANUFACTURE and sell the finest low priced coin counting-packaging and coin sorting machines available. Write for details. KLOPP ENGINEERING, INC. 35561 SCHOOLCRAFT RD. LIVONIA, MICHIGAN 48151.

GOTTLIEB TROPIC ISLE \$190.00—SLICK Check \$235.00—Want 6 Pocket Pool tables—state price condition, make, model and size in 1st letter—SEEBURG L 100's NOBRO NOVELTY CO. 142 DORE ST., SAN FRANCISCO, CALIF. MARKET 1-15438-39.

HAVE YOUR ACE LOCKS KEYS LIKE \$1.00 each 10% off 50 or more. Send your locks with key you want as master to L & S LOCK CO., 41 ELDERWOOD LANE, HUNTINGTON STATION, N. Y. LARRY SCHWARTZ, FORMER SERVICE MANAGER OF CONTINENTAL APCO.

UNITED 16' FALCON B.A. \$425; 16' JUMBO B.A. \$195; Silver Roll-Down \$550; Super Slugger Baseball \$95; Shuffle Baseball (Floor sample) \$95; ChiCoin: Six Game Bowler S/A \$325; 6-Pl. Home Run Baseball \$95; WMS. Titan Gun \$325; Midway; Slugger Baseball \$350; Deluxe Shooting Gallery \$325; CENTRAL OHIO COIN-MACHINE EXCH., INC., 315 E. 5TH AVE.—COLUMBUS 1, OHIO. (Tel. 394-3529).

ATTN: COIN OPERATORS AND WHOLESALEERS. Something to revolutionize the pool industry. Save 97% repair time, money and service. 1 and 2 piece fiber glass cue sticks. Also accessories. Dealerships available. For information contact: KING KOIN "O", 713 BOYINGTON, IRON RIVER, MICHIGAN.

PAMARAM OPERATORS: HAS YOUR TAKE dropped? Change your films to up to date, action packed films of young beautiful models. Color or b/w. We are shooting talent every week. KOLOR KADE PRODUCTIONS, 547 NINTH AVE., SAN DIEGO, 1 CALIF.

AUTOPHOTO'S, FOUR #9's LATE. \$695 EA. Un. phono UPD 100 \$399.50. Seeb. E2 Cig. \$195. Rowe Ambassador Cig. 14 col. \$135. Bally Fire Chief ride \$399.50. Aqua Jet ride \$199.50. Greco Bros. AMUSEMENT CO., 1288 B'WAY, ALBANY, N.Y. Tel. HO 50208.

SEEBURG 222—\$545, 220—\$475, KD HDW.—200, 3 WA-200 Wallboxes—10 for \$200, Wurlitzer 2500—\$475, 2410—\$375, 2300—\$275, 2100—\$100, 4—2000—Make offer. BIRD MUSIC DISTRIBUTORS, INC., 124-126 POYNTZ, Manhattan, Kansas, PHONE PR 8-5229.

IF IT'S PANORAM PARTS YOU WANT PHIL GOULD HAS 'EM. ALL TYPES OF FILMS FOR Panoram Peeks. PHIL GOULD—224 MARKET ST.—NEWARK, N.J. (Tel. 201-MARket 4-3297).

ATTENTION: WHOLESALERS AND EXPORTERS. Write for our prices on phonographs ready for export shipment. UNITED DIST. INC.—902 WEST SECOND STREET—WICHITA 3, KANSAS.

WE HAVE LARGE SELECTION OF LATE Williams and Gottlieb games. Tell us your needs. We guarantee lowest prices. CENTRAL DIST. INC., 2315 OLIVE ST., ST. LOUIS, MO. 63103 (Tel. MA 1-3511)

POKERINO, RECONDITIONED, REFINISHED in Blond Birch, with new drop crute, points, sockets, wire, knock off, trim, back-glass, playfield decals. Write for details. New socket and point drop board wired for your games. JAMES TRAVIS—P.O. BOX 206—MILLVILLE, N.J. 08332

BEST IMPORTED ARITHM CUE BALLS 2 3/8" and—Pool Sets—Lowest Prices. State Quantity. SEACOAST DISTRIBUTORS, 1200 NORTH AVENUE, ELIZABETH, NEW JERSEY 07201. BIGELOW (201) 8-3524-5.

"CLOSEOUT" NEW ROWE AMI—TROPICANA Phonograph Original Crate—Write; Reconditioned Equipment—All the Way, \$295; Bally Bucky Horse, \$495; Auto-Photo, Mod. #9, \$745; New Bally Bullfight, \$375. ADVANCE DISTRIBUTING COMPANY, 4710 DELMAR BLVD., ST. LOUIS, MISSOURI TEL. Forest 1-1050.

BINGO SPECIALS. ALL FULLY SHOPPED AND reconditioned. Bounties \$750.00. Silver Sails \$750.00. Golden Gates \$710.00. Can Can \$650.00. Laguna Beach \$500.00. Carnival Queen \$375.00. Ship port of New Orleans. OPERATORS SALES, INC., 4122 WASHINGTON AVE., NEW ORLEANS, LOUISIANA, 822-2370.

FOR EXPORT: BALLY TURF KINGS, CYPRESS Gardens Carnival Queen, Ballerina, Miss America, Laguna Beach and all other bingos. Rockola 1448, 1458, 1468, 1478, 1493. Keeney Twin Red Arrow, Flashback, Games Super Wild Cat; Mills & Jennings Fruit Slat Machines. Bowl A Rama & Princess B. A., Buckley Track Odds, Flippers & Add A Balls. CROSSE-DUNHAM & CO. 225 WRIGHT BLVD. "F" GRETNA, LA. TEL. 367-4365.

GOTTLIEB SLICK CHICK \$235, TROPIC ISLE \$185, Aloha (2 Pl.) \$250, Oklahoma (4 Pl.) \$275, World Beauties \$75, Williams: Sere-nade (2 Pl.) \$125, Jungle \$150, Ten Spot \$195, Bally Cross Country \$175, Wurlitzer 1800, good condition \$175. We are central Pennsylvania's largest supplier of Pool Table equipment at Lowest Prices. D & L COIN MACHINE CO., 414 KELKER ST., HARRISBURG, PA. 17105 (234-1051).

BINGO SALE: BOUNTYS \$695; SILVER SAILS \$695; Golden Gates \$650; Lidos \$500; Can Cans \$500; Laguna Beaches \$450; County Fairs \$395; Sea Islands \$295; Carnival Queens \$245. CONTACT NASTASI DISTRIBUTING COMPANY, 826 BARONNE STREET, NEW ORLEANS, LOUISIANA (523-6386 & 523-1471).

UNITED SHUFFLES: CRYSTAL \$325.00; Avalon \$350.00; Action \$375.00; Lancer \$395.00. ChiCoin Citation \$375.00. MO-HAWK SKILL GAMES CO., 67 SWAGGER-TOWN ROAD, SCOTIA, N.Y. 12302.

GOTTLIEB: HAPPY CLOWN \$495; WILLIAMS: Whoopees \$410; River Boat \$290; Bally; Big Day \$395; Sheba \$375; Grand Tour \$225; Chicago Coin: Majestic bowler 16' \$625; Cadillac bowler 16' \$525; Bngos: Bountys: Carnival Queens: Lidos: Can Cans: Bikinis: Touchdowns: Twists: Silver Sails: Beach Time. If interested write NEW ORLEANS NOVELTY CO., 1055 DRYADES STREET, NEW ORLEANS, LOUISIANA, Tel: 529-7321.

BRAND NEW KEENEY BLACK DRAGONS, Keeney Deluxe Red Arrows, Keeney Twin Dragons and Star Lite uprights. SASKATCHEWAN COIN MACHINE CO., 1025 104TH STREET, NORTH BATTLEFORD, SASK., CANADA. (Tel. 2989).

MILLS AND JENNINGS FRUITSLLOT MACHINES. BALLY BINGOS and Flipper Pin Games for export. ALMAN ENTERPRISES—BENDER WAREHOUSE—P.O. BOX 5734—RENO, NEVADA.

FOR SALE—WE CARRY A COMPLETE LINE of coin counters, (new or used) coin sorters, coin changers, coin wrappers, parts and supplies. Globe Distributing Co., Inc., 2330 N. Western Ave., Chicago 47, Ill. AR 6-0780.

MISC.

30,000 PROFESSIONAL COMEDY LINES! Largest laugh library in show business. 38 books; over 450,000 copies sold. Used by 1,000 disc jockeys! Orben's Current Comedy our monthly topical gag service features deejay material each issue. Free catalog. Write: ORBEN DEE-JAY LAUGHS, 3536 DANIEL CRESCENT, BALDWIN HARBOR, N.Y. 11510.

CAJUN MUSIC FROM LOUISIANA! Singles and Albums! Free List. Operators: Cajun singles in C&W locations will prove profitable. Trial offer: Ten different Cajun Singles with strips, \$5.00 (check, M.O. or \$1.00 deposit COD). FLOYD'S RECORD SHOP, Ville Platte, Louisiana 70586.

CHICAGO COIN'S

Preview Bowler

6-PLAYER AUTOMATIC BOWLING LANE

with exclusive
**SWIVEL
SCORE RACK**

- Front or Back Score Rack Serviced From Either Side

NEW EXTENDED PLAY FEATURE

- FIRST TIME EXTENDED PLAY USED ON A BOWLING LANE!
- IF ANY ONE OF A GROUP OF PLAYERS SKILLFULLY WINS AN EXTENDED PLAY — ALL WIN!

- REGULATION
- DUAL FLASH and
- FLASH-O-MATIC SCORING

PLUS THESE CHICAGO COIN FEATURES!

- Sturdy Contemporary Cabinet With Inset Legs.
- Latest Fluorescent Lighting.
- Individual Name Feature.
- Flash-Bonus Score Game. Bonus Score Collected in 11th Frame.
- Red Pin Game. Red Pin Bonus Score For Strikes in 3rd, 6th & 9th Frames.

New, Larger
Cash Box

AVAILABLE IN 13' and 17' LENGTHS
Extension Available in 4' and 8' Lengths

YOUR CHICAGO COIN DISTRIBUTOR IS NOW DELIVERING THESE PROVEN PROFIT MAKERS

BIG LEAGUE
2-PLAYER
BASEBALL GAME

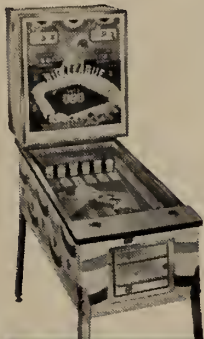

Gold Star
EXTENDED PLAY
PUCK
BOWLER



PAR GOLF
COMING
YOUR WAY
SOON...

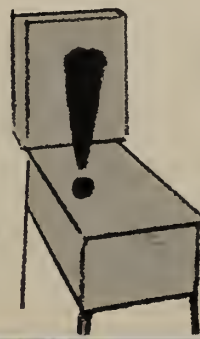

Mfrs.
of
PROVEN
PROFIT MAKERS
Since
1931

CHICAGO COIN MACHINE DIV.

CHICAGO DYNAMIC INDUSTRIES, INC.

1725 W. DIVERSEY BLVD., CHICAGO, ILLINOIS 60614

Greatest of
all automatic
entertainers
the
world
over

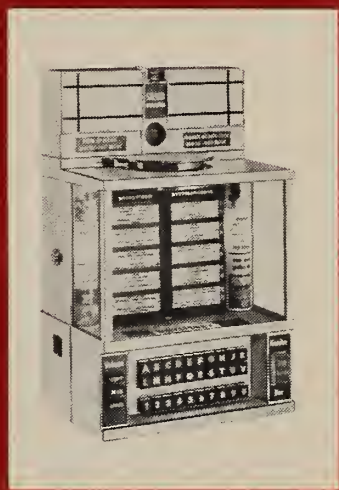

Wurlitzer's global-wide contribution to coin-operated music is recognized wherever people gather to enjoy their native foods and beverages.

Phonographs are offered in 200 and 100 selections as well as a special Discothèque model. Only Wurlitzer offers true high fidelity stereophonic sound, plus such features as the **Golden Bar** enabling the pre-selection of a number of tunes for a pre-determined coin from both the phonograph and private listening wallboxes.

WURLITZER Music Systems

THE WURLITZER COMPANY
109 YEARS OF MUSICAL EXPERIENCE
NORTH TONAWANDA, N. Y.

 *Williams*® **BIG 3** FOR BIG PROFITS!

POT O' GOLD

2 PLAYER

the game with the big 

United's

PYRAMID

SHUFFLE ALLEY

and

OASIS

BOWLING
ALLEY

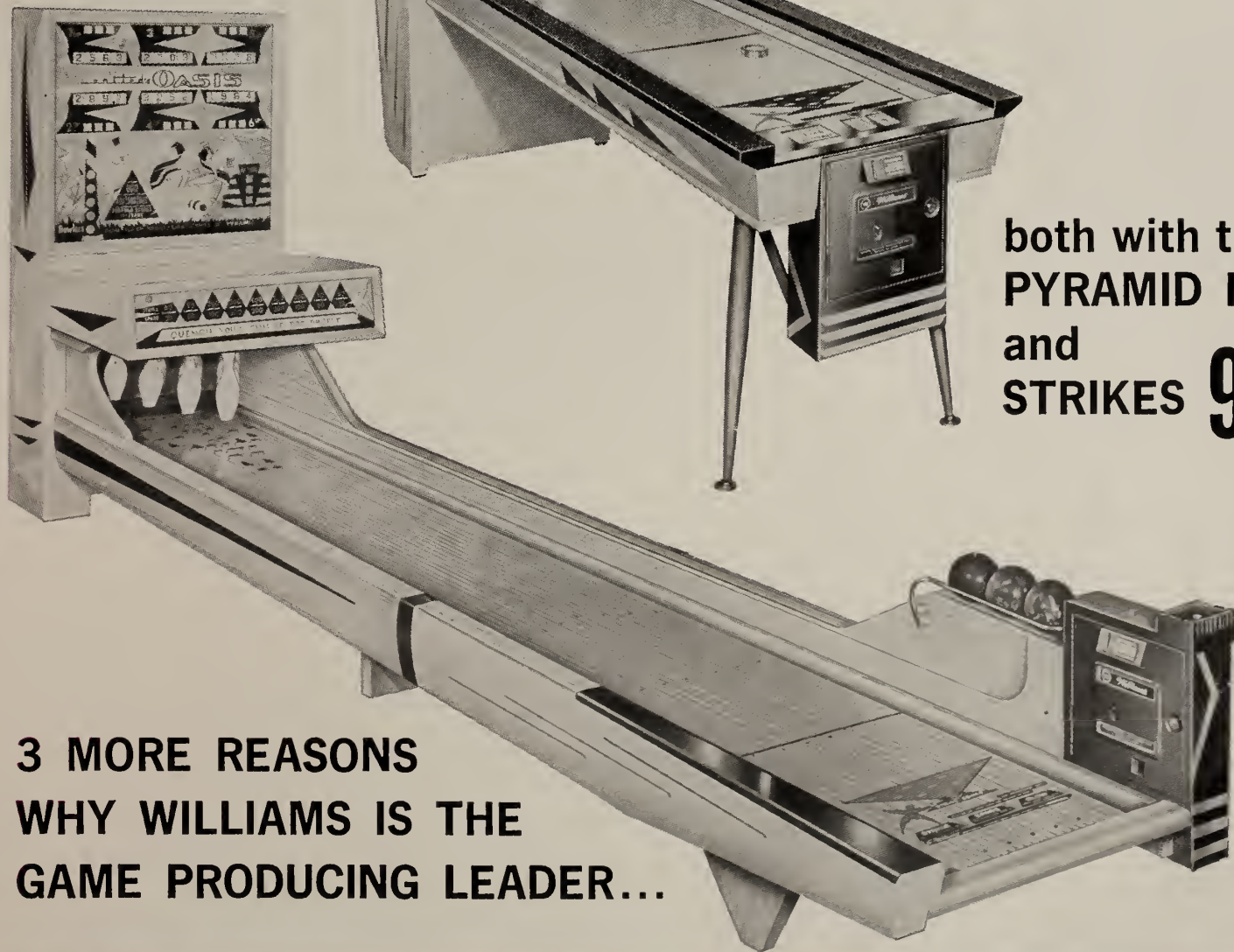

both with the
PYRAMID FEATURE
and
STRIKES 90

**3 MORE REASONS
WHY WILLIAMS IS THE
GAME PRODUCING LEADER...**



Williams® **ELECTRONIC MANUFACTURING CORP.**

3401 North California Ave. Chicago, Illinois 60618 • Cable address: WILCOIN, CHICAGO

AVAILABLE FOR IMMEDIATE DELIVERY THROUGH YOUR WILLIAMS DISTRIBUTOR

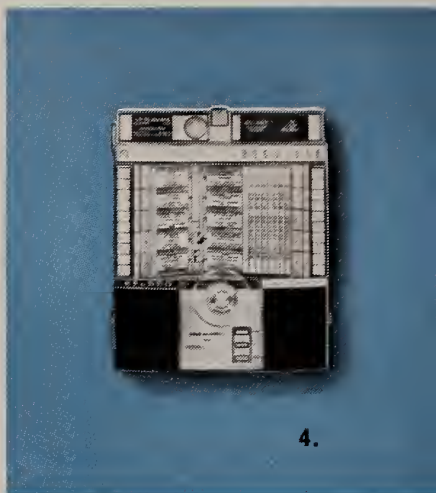

music! cold drinks! cigarettes! hot drinks!

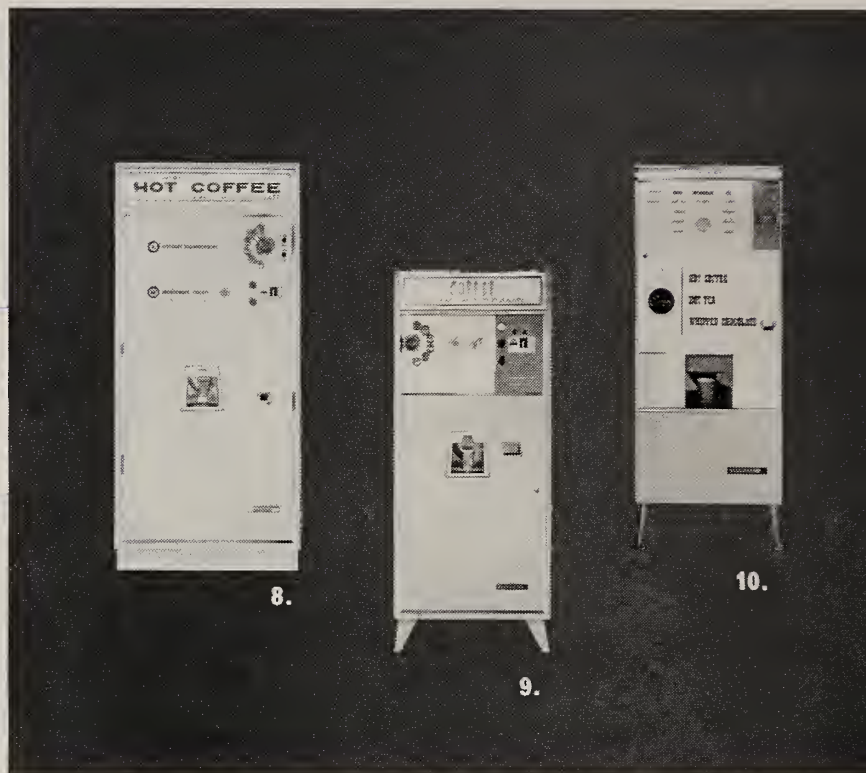
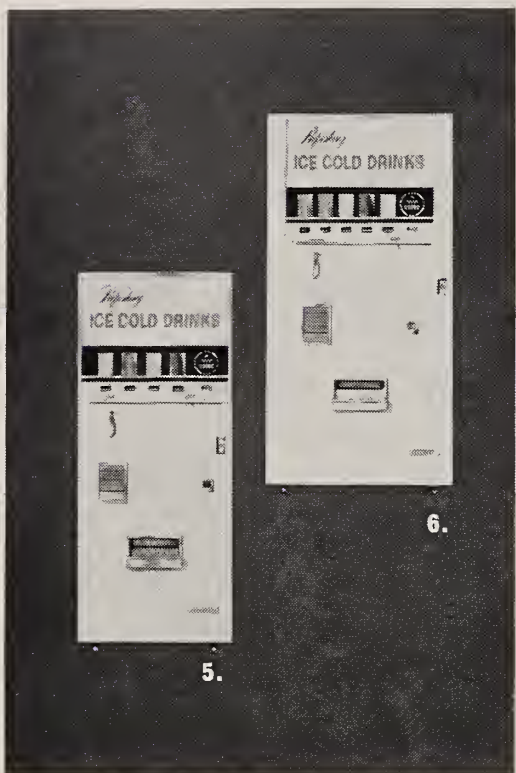

1. **Princess Royal Model 424.** Compact 100 selection stereo-monaural phonograph. Full dimensional sound. Plays 33½ or 45 RPM records, 7" LP albums or singles in any intermix. Exclusive Rock-Ola revolving record magazine.
2. **The Starlet Model 429.** Rock-Ola's newest sensation in sound reproduction. Compact 100 selection stereo-monaural phonograph for locations where economy and space are important. Intermixes 33½ or 45 RPM records in any sequence. Exclusive Rock-Ola revolving record magazine.
3. **Grand Prix II Model 426.** Prestige stereo-monaural 160 play phonograph. Plays 33½ or 45 RPM records, 7" LP albums or singles in any intermix. Full dimensional sound. Exclusive Rock-Ola revolving record magazine.

4. **Phonette Wallbox Model 500.** 160 selection remote speaker wallbox gives personal listening and volume control. Twin stereo speakers. Works with almost any phonograph. Model 501—100 selections.
5. **Can Cold Drink Vendor Model 3301/Type 340.** New 340 capacity can cold drink vendor features exclusive spray-proof can opener. Vends four flavors in four chutes. Pre-cools 48 12-ounce cans.
6. **Can Cold Drink Vendor Model 3302/Type 420.** The largest can capacity of any vendor. 420 can total capacity with 55 12-ounce cans in pre-cool. Vends five flavors. Five vending columns. Exclusive spray-proof can opener.
7. **Caravelle Cigarette Vendor Model 3002.** Best built cigarette machine on the market. Every component unitized. Packs a full line...20 packs. 800 pack capacity.

8. **Batch Brew Coffee Vendor Model TRLB-M.** High profit vendor for high volume locations. Serves flavor-rich coffee four ways. Also hot whipped chocolate, soup or tea.
9. **Single Cup Fresh Brew Coffee Vendor Model 1404-S.** Brews fresh roasted coffee one cup at a time. Ideal for discriminating locations. Serves it four ways plus hot chocolate and hot soup.
10. **Coffee and Hot Drink Vendor Model 3402.** Perfect small location vendor. Serves soluble coffee or tea four ways. Also hot whipped chocolate.



**INCREASE
YOUR TAKE!
MAIL THIS
COUPON TODAY**

ROCK-OLA
the
dependable line

ROCK-OLA MANUFACTURING CORPORATION

800 North Kedzie Avenue, Chicago, Illinois 60651

Gentlemen:
Rush me detailed information on your vending line.

- | | |
|---|--|
| <input type="checkbox"/> Rock-Ola Coffee and Hot Drink vendors. | <input type="checkbox"/> Rock-Ola Can Cold Drink Vendors. |
| <input type="checkbox"/> Rock-Ola Caravelle Cigarette Vendor. | <input type="checkbox"/> Rock-Ola Phonographs and Wallbox. |
| <input type="checkbox"/> The entire Rock-Ola vending line. | |

Name _____

Address _____

City _____ State _____ Zip Code _____