

監修：庵野 秀明  
発行：カラー

# Groundwork of EVANGELION

## The Movie 1

新世紀エヴァンゲリオン劇場版原画集







# Groundwork of EVANGELION The Movie 1

新世紀エヴァンゲリオン劇場版原画集



## 目 次

はじめに .....	29
DEATH .....	30
Air .....	52
【特典】 .....	365



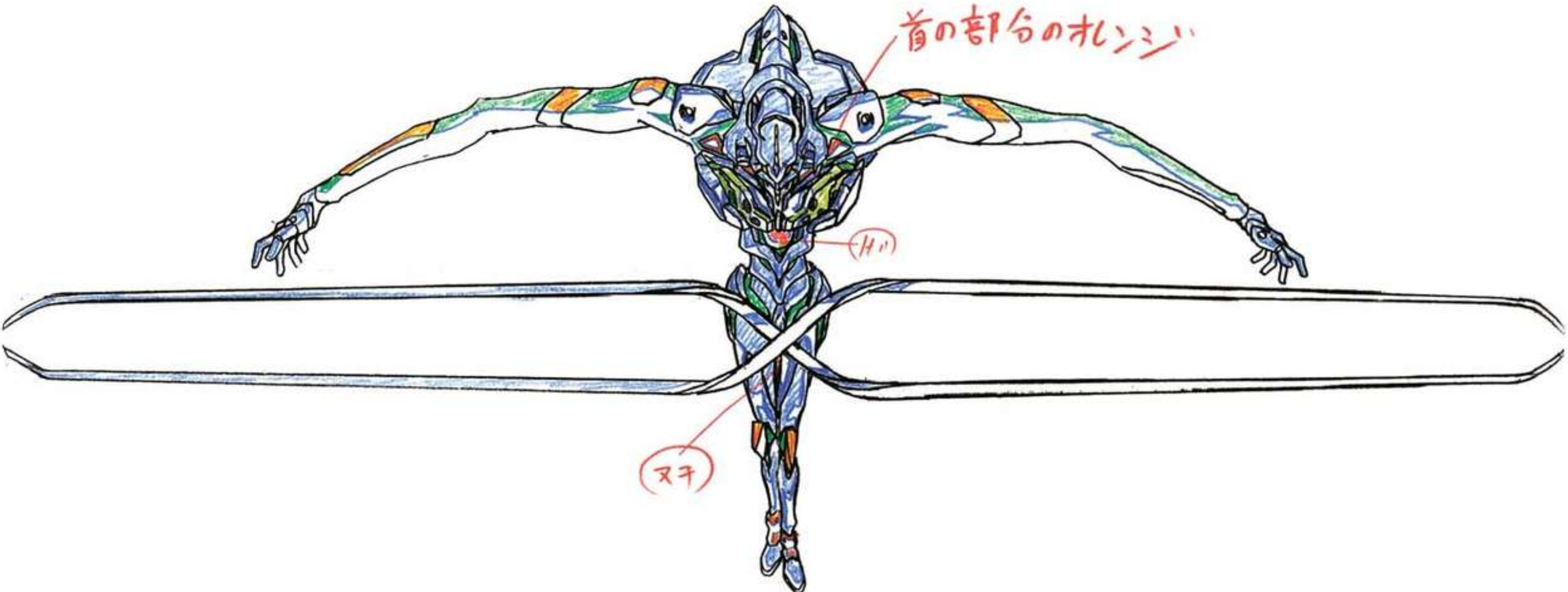

# Groundwork of EVANGELION The Movie 1

新世紀エヴァンゲリオン劇場版原画集



監修:庵野秀明

原画:摩砂雪  
初出:新世紀エヴァンゲリオン劇場版DVDポスター



(F)

Attr

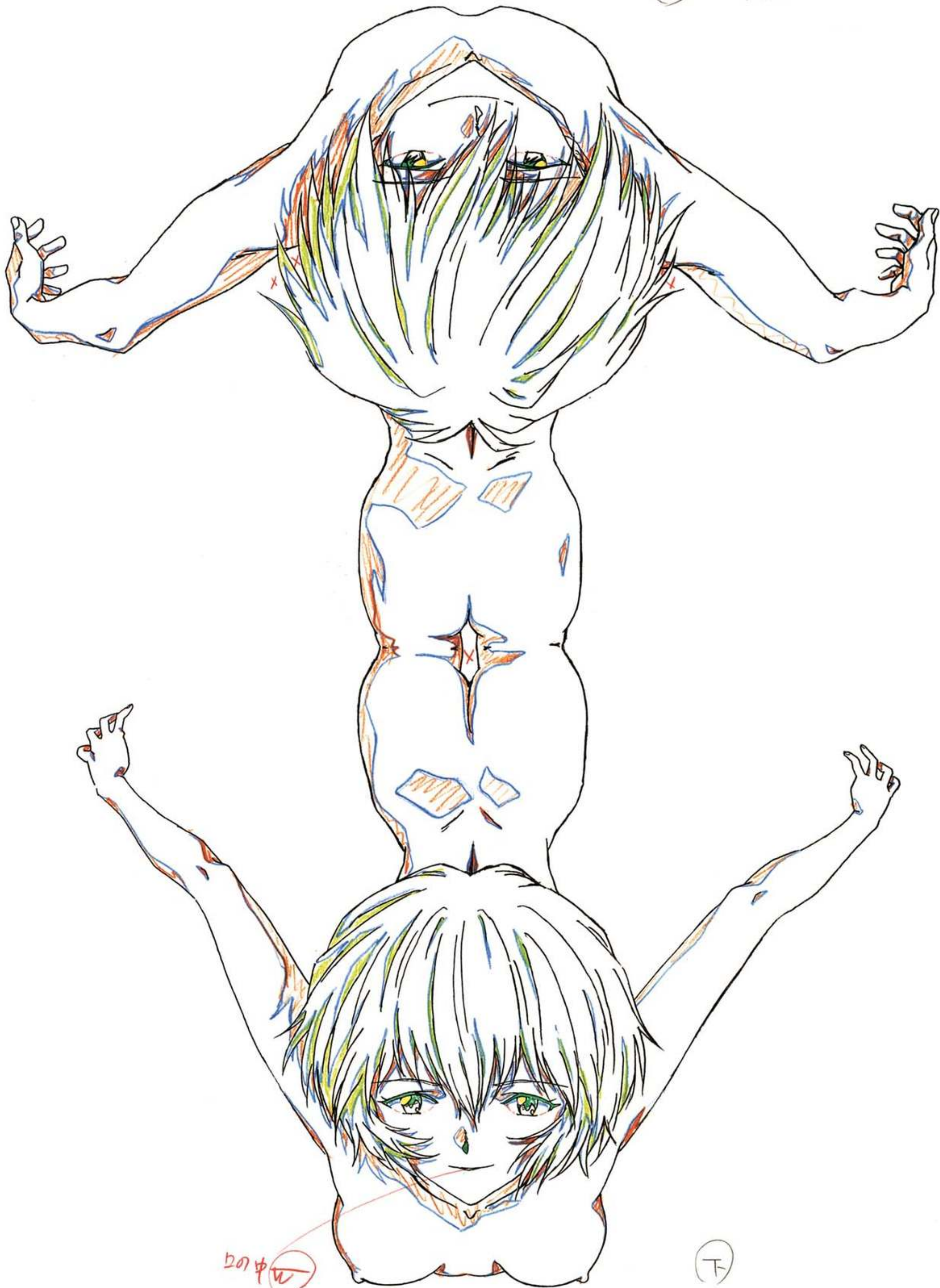

2014

(T)







CI



十字架のHは色のみ

ミサトの服  
カラー

ミサトの服  
カラー

ヒカリです

色D

服A=ス  
100  
80

⑥60  
NR01

⑦20  
NR01

35 BL

肩60  
20

80  
40

内着  
K7  
BL

60  
20

⑥60  
30

肌  
90  
60

肌②20  
NR01  
BL

色D

色D  
HIGERORY

⑥60  
NR01

212  
20  
NR01

加  
幅  
90

肌  
90  
60

⑦20  
NR01

⑦20  
NR01

⑦20  
NR01

⑦20  
NR01

⑦20  
NR01

⑦20  
NR01

⑦20  
NR01

⑦20  
NR01

⑦20  
NR01

⑦20  
NR01

⑦20  
NR01

⑦20  
NR01

⑦20  
NR01

⑦20  
NR01

⑦20  
NR01

⑦20  
NR01

⑦20  
NR01



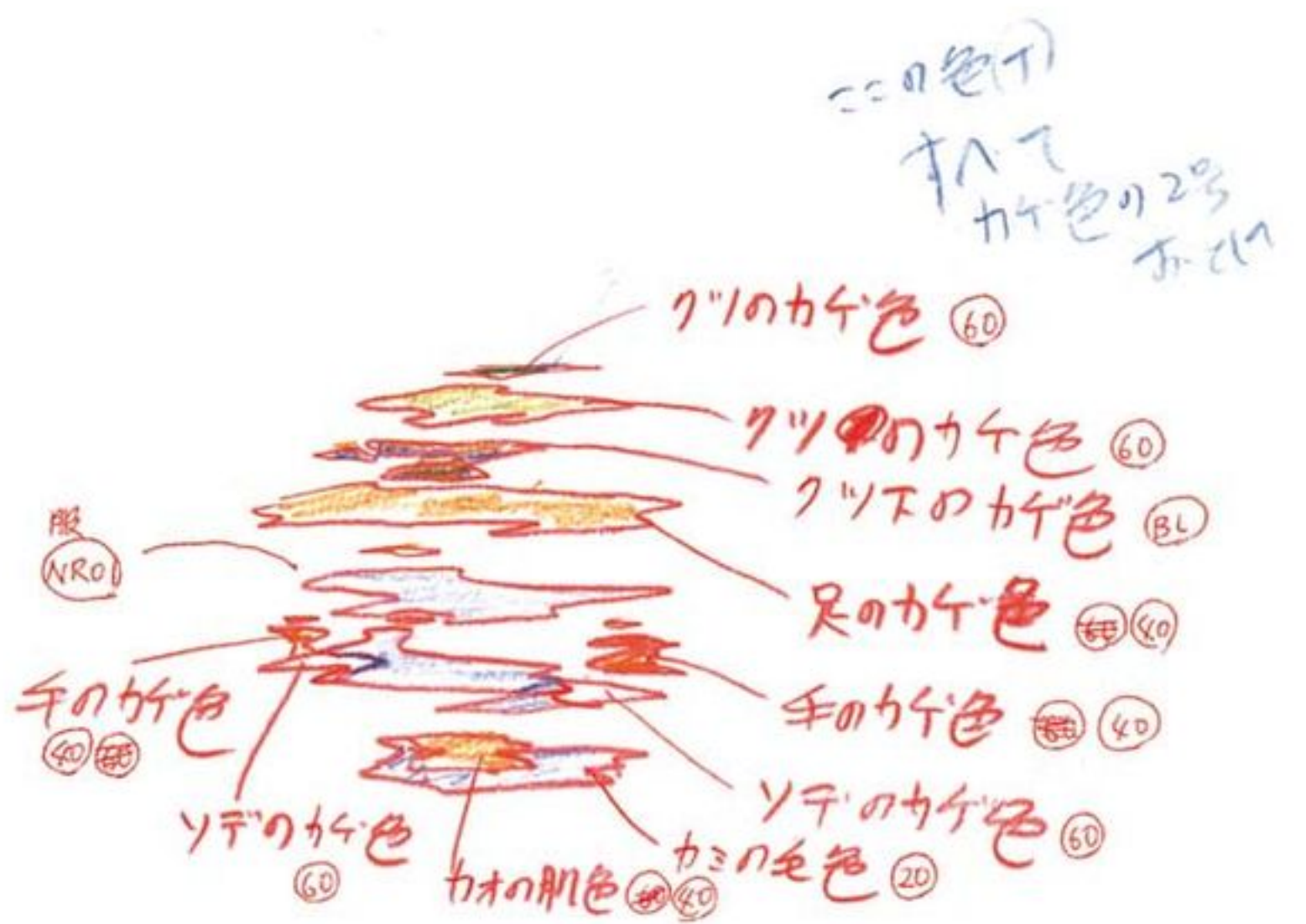
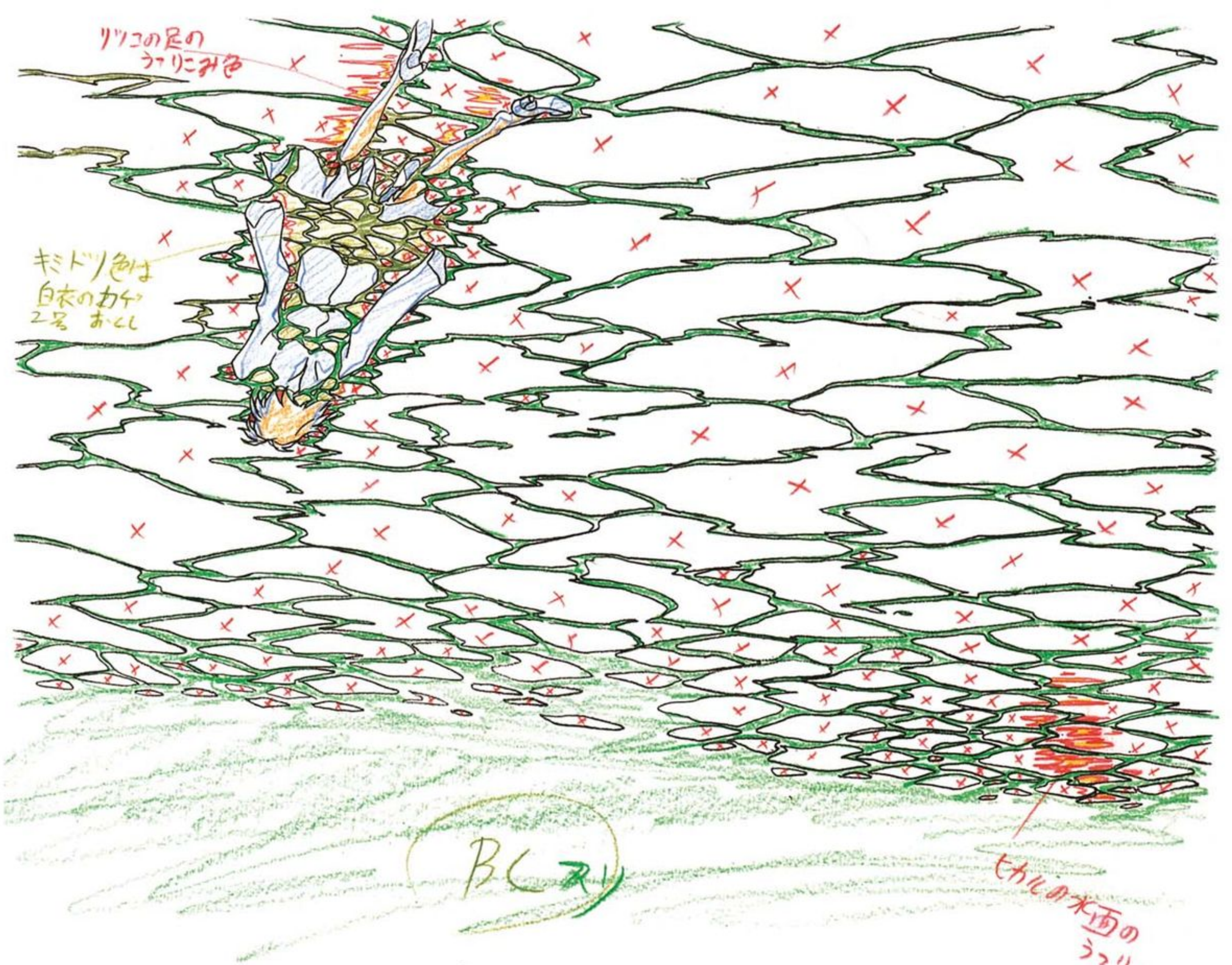



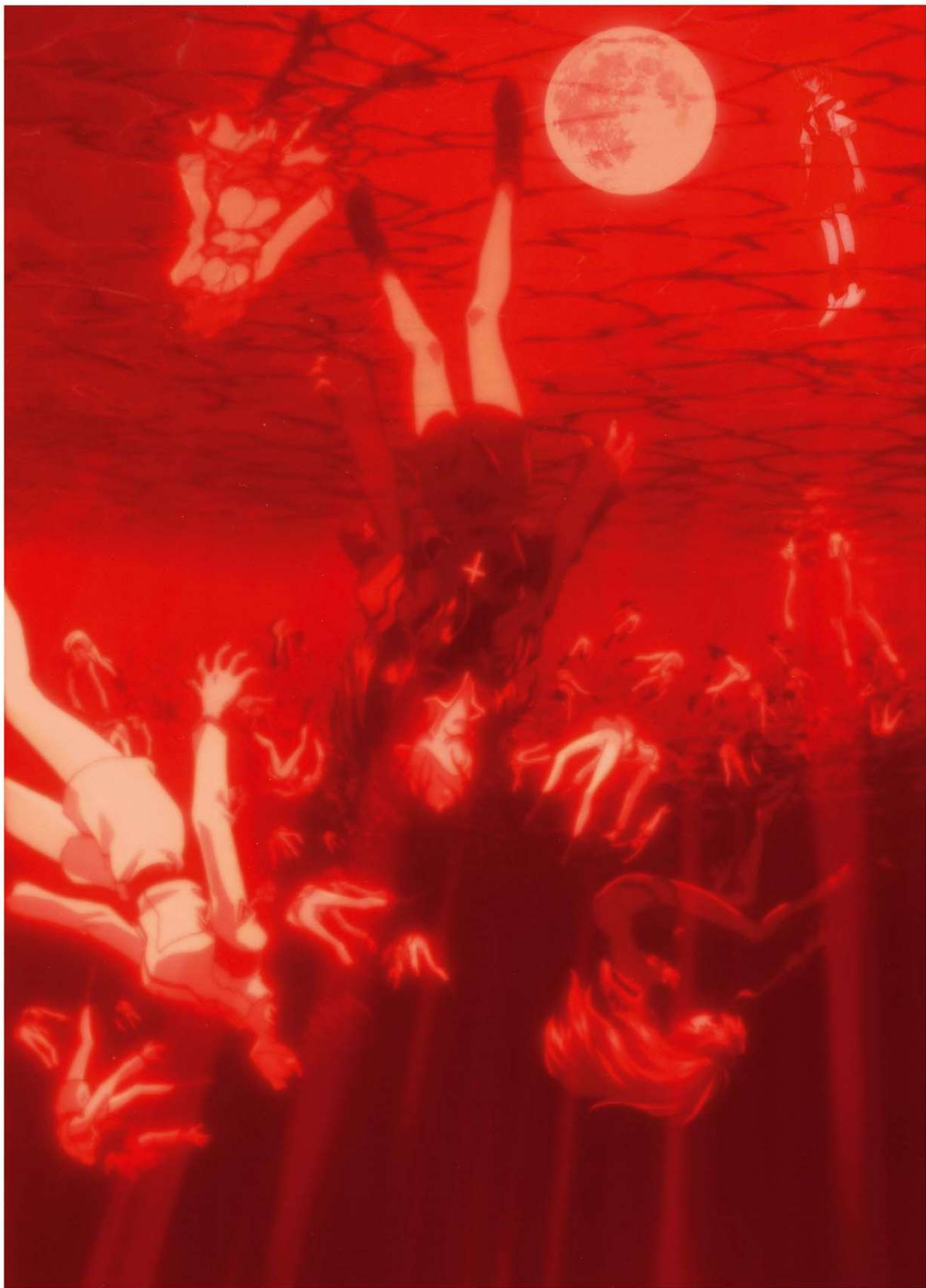



原画：鈴木俊二  
初出：新世紀エヴァンゲリオンコレクターズディスクVOL.5パッケージ





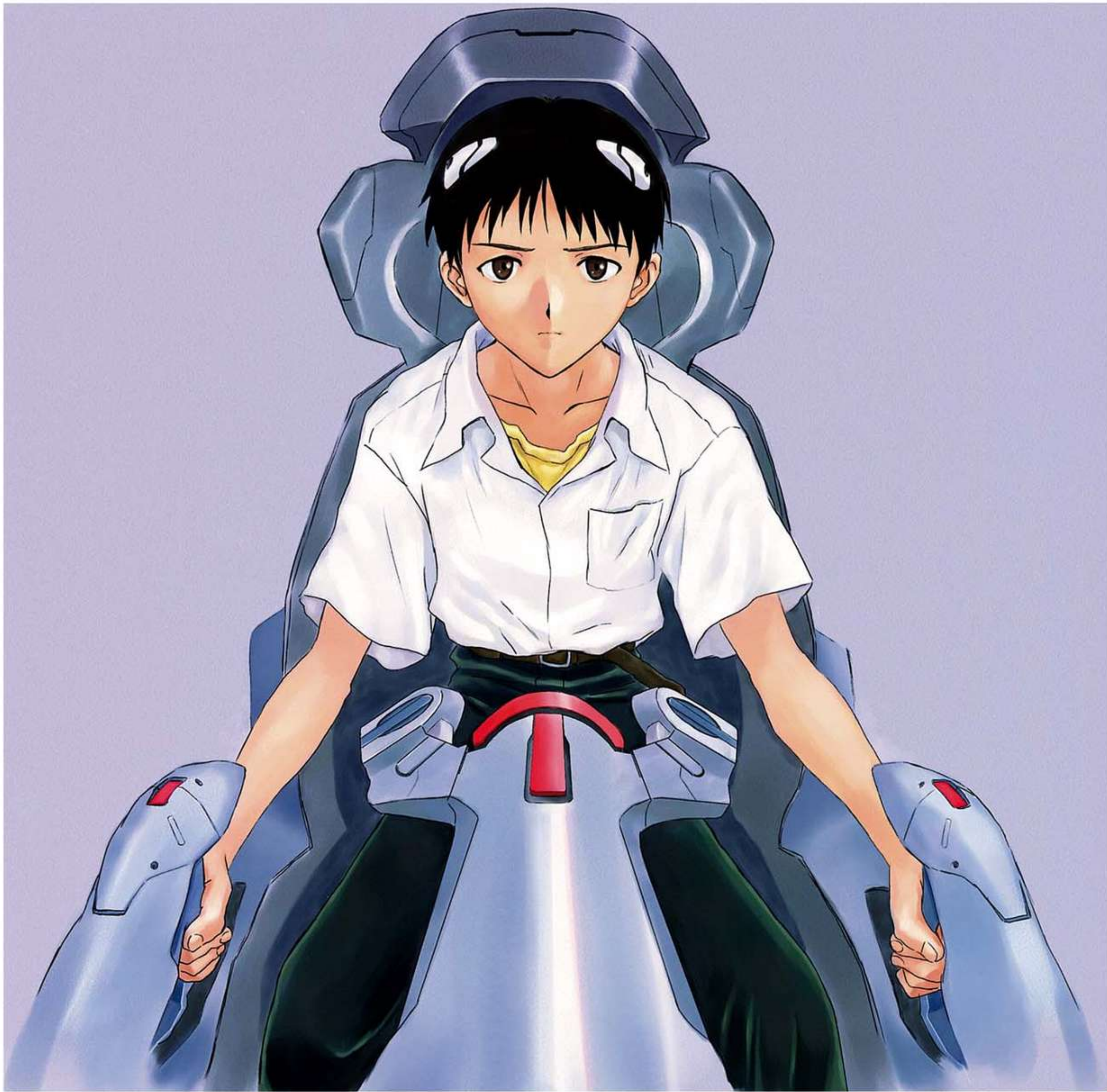

初出：新世紀エヴァンゲリオン DVDシリーズ VOL.1パッケージ  
原画：鈴木俊二











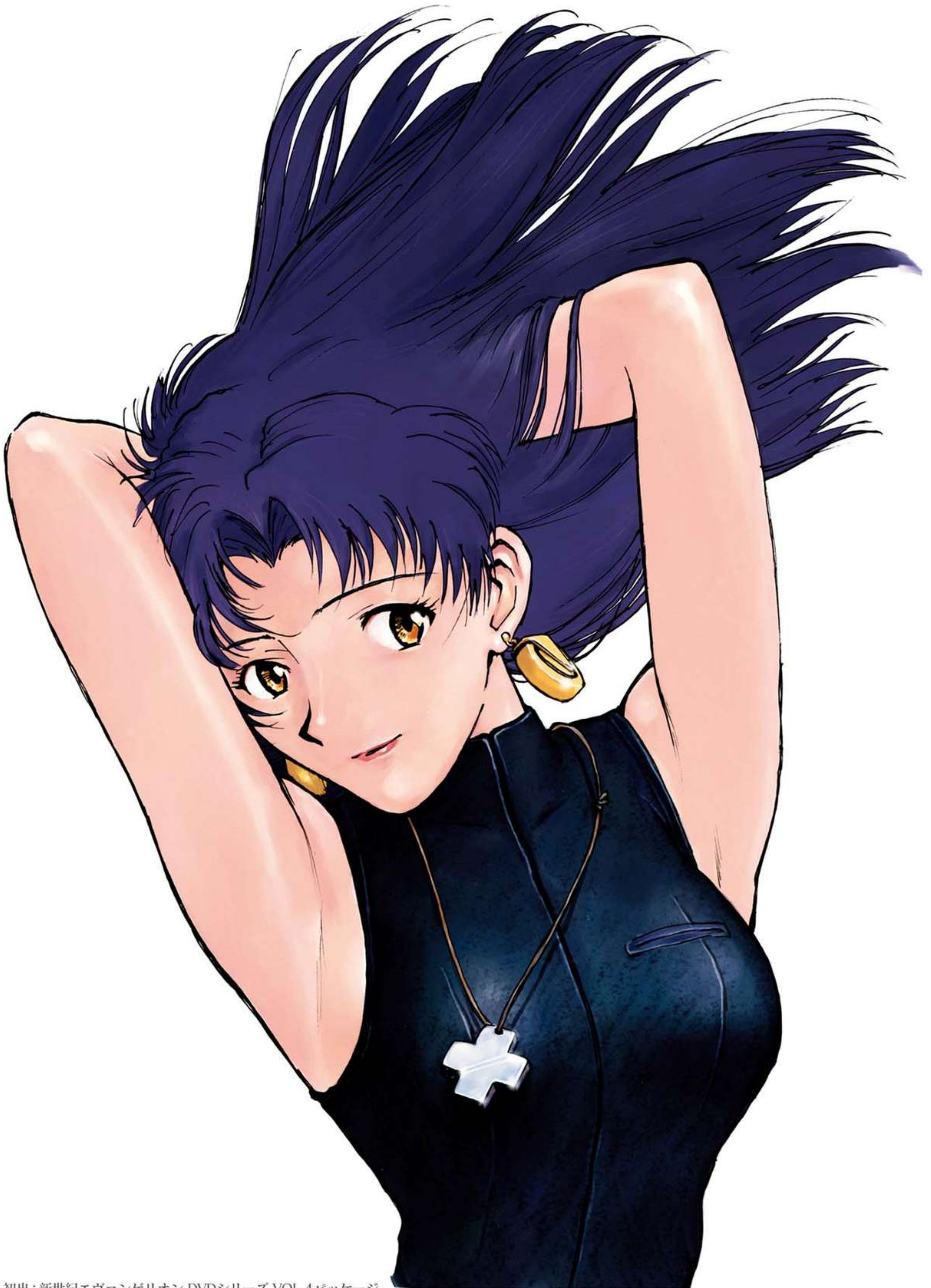

初出：新世紀エヴァンゲリオン DVDシリーズ VOL.4パッケージ  
原画：鈴木俊二





初出：新世紀エヴァンゲリオン DVDシリーズ VOL.5パッケージ 原画：鈴木俊二















初出：EVANGELION ORIGINAL  
(新世紀エヴァンゲリオン脚本集) 1 カバーイラスト  
原画：鈴木俊二



▼原画：鈴木俊二  
初出：EVANGELION ORIGINAL  
(新世紀エヴァンゲリオン脚本集) 1 イラスト見開き









初出：EVANGELION ORIGINAL (新世紀エヴァンゲリオン脚本集) 1 イラスト  
原画：鈴木俊二









初出：EVANGELION ORIGINAL (新世紀エヴァンゲリオン脚本集)2 イラスト  
原画：鈴木俊二





初出：EVANGELION ORIGINAL (新世紀エヴァンゲリオン脚本集) 2 イラスト  
原画：鈴木俊二



























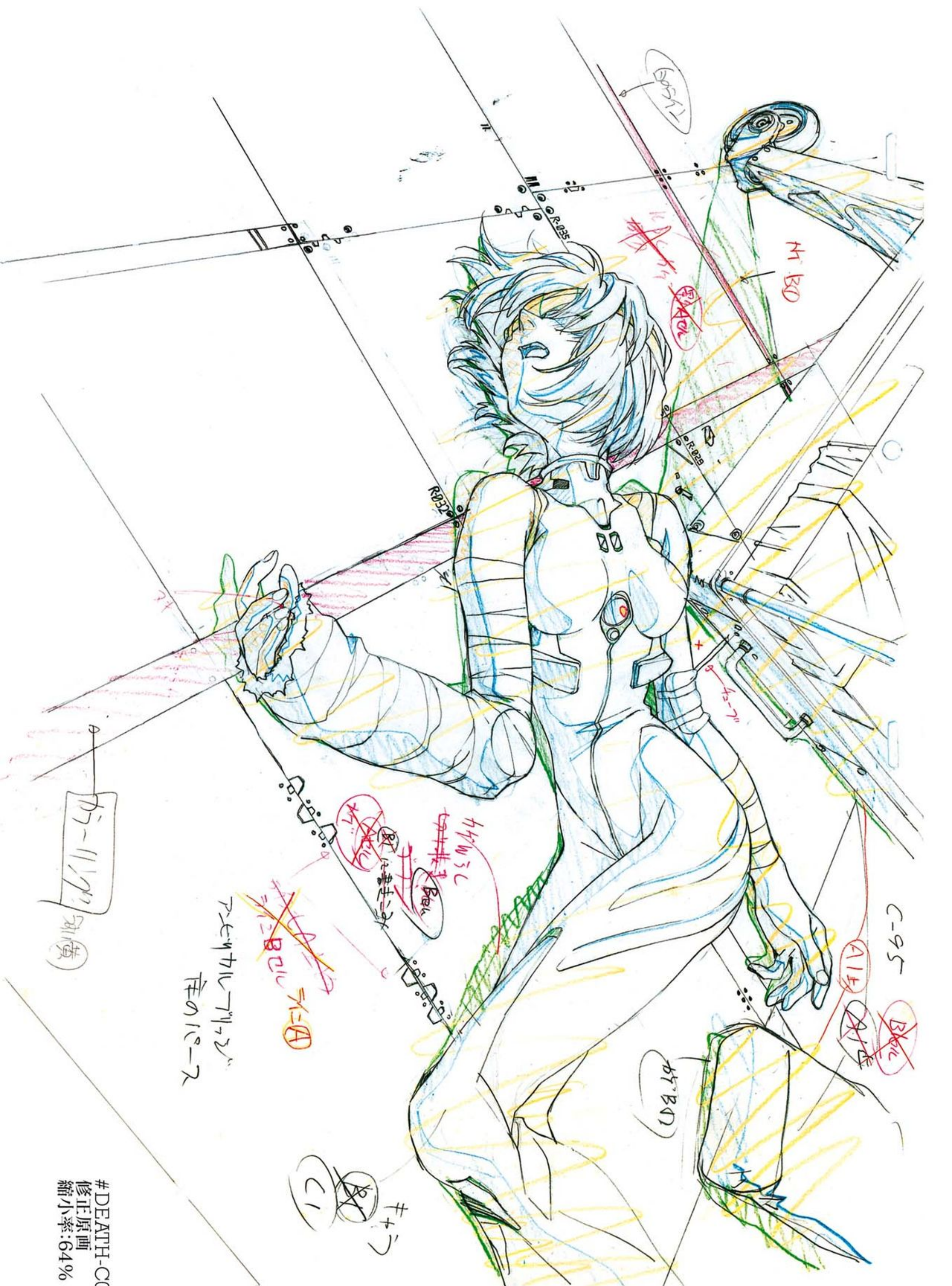

C-95

~~A14~~

~~A15~~

~~B16~~

(M-BD)

~~R032~~

#47

~~M-BD~~

M=A

カクワスC

Baku

デジタル  
フェイス

カクワスC  
加黄

#DEATH-C095  
修正原画  
縮小率:64%



# Groundwork of EVANGELION Movie 1

はじめに。

1993年、『エヴァ』の企画当初、私は従来の4：3のスタンダードサイズではなく35mmフィルムによる16：9のビスタサイズでの放映を画策していた。次世代を考え、ワイドテレビ対応の新たな形態によるアニメシリーズを狙ったものだ。

が、時期早々、更に系統的にも問題視され、残念ながら実現には至らなかった。つまり、ビスタサイズは、『エヴァ』本来の姿と云える。

しかしながら、映画化の企画当初は、1：2.35のシネスコサイズも検討していた。自分にとって劇場映画といえばシネスコ、というイメージは払拭しきれぬものがあるからだ。余談だが、その願いは実写映画『式日』にてようやく叶う。やはりアナモレンズによって広がる空間は、劇場映画ならではのものだと感じる。

だが、あえて『エヴァンゲリオン劇場版』は、いわゆる85ビスタ、つまり画面が1：1.85サイズのフレームで描かれている。画面サイズは、作品にとって最も似合うものを選ぶに過ぎないからだ。作業的には、TVシリーズのスタンダードサイズの上下を切った、いわゆる貧乏ビスタと横長の大き目の用紙による、通常ビスタとを各カットにより使い分けて描いてある。レイアウト用紙の大きさを統一するのを感じなかったからだ。経済的、効率的な理由等もあり、この方式を選んだ。それが、ベストだったからである。その判断は今でも良かったと思う。やっぱシネスコだと横長の艦船等と違って、縦長の巨大ロボットでは、画面に収まりづらいからなあ。うん。

その劇場公開を前提とした作品ゆえに描かれている、TVモニターサイズではなく大画面と横長を意識した画面構成、密度、情報、技術等を、本原画集にて「線画」というピュアな状態でお楽しみいただければ、幸いです。

本巻では、現存する原画を可能な限り回収し、その中から劇場版シト新生の追加修正及び劇場版25話から選出し、紙面の許す限り載せております。

しかし、すでに所在不明の原画が多々ありその全てを掲載することは物理的に不可能でした。申し訳ありません。

なお、作画監督による修正原画は、その目的から完成したセル画より線が足りない部分もありますが、これらは部分修正によるもので、決して線が抜けているわけではありませんので、あしからず。

また、一部の原画に関しては、原画と修正原画を併載してあります。これは作画監督の仕事の一部を紹介するという意図によるもので、その原画に何か問題があるという事等ではありません。他意の無きものです。

そして、レイアウトやタイムシート等も参考になればと、一部掲載してあります。

あと、いかんせん、月日が経っている為、生原画の保存状態の問題やオリジナル散逸によりやむなくコピー紙・セル画から収録した原画等にあたっては、可能な限り修正いたしました。多少の御見苦しい点は、御容赦下さい。

今、また劇場版、及び編集スタッフに心から感謝いたします。

ありがとうございました。

そして『エヴァ』原画集の第1巻から、早1年。

こうして劇場版まで出せるのも、皆様のおかげです。

ありがとうございます。

庵野秀明  
2001/09/26



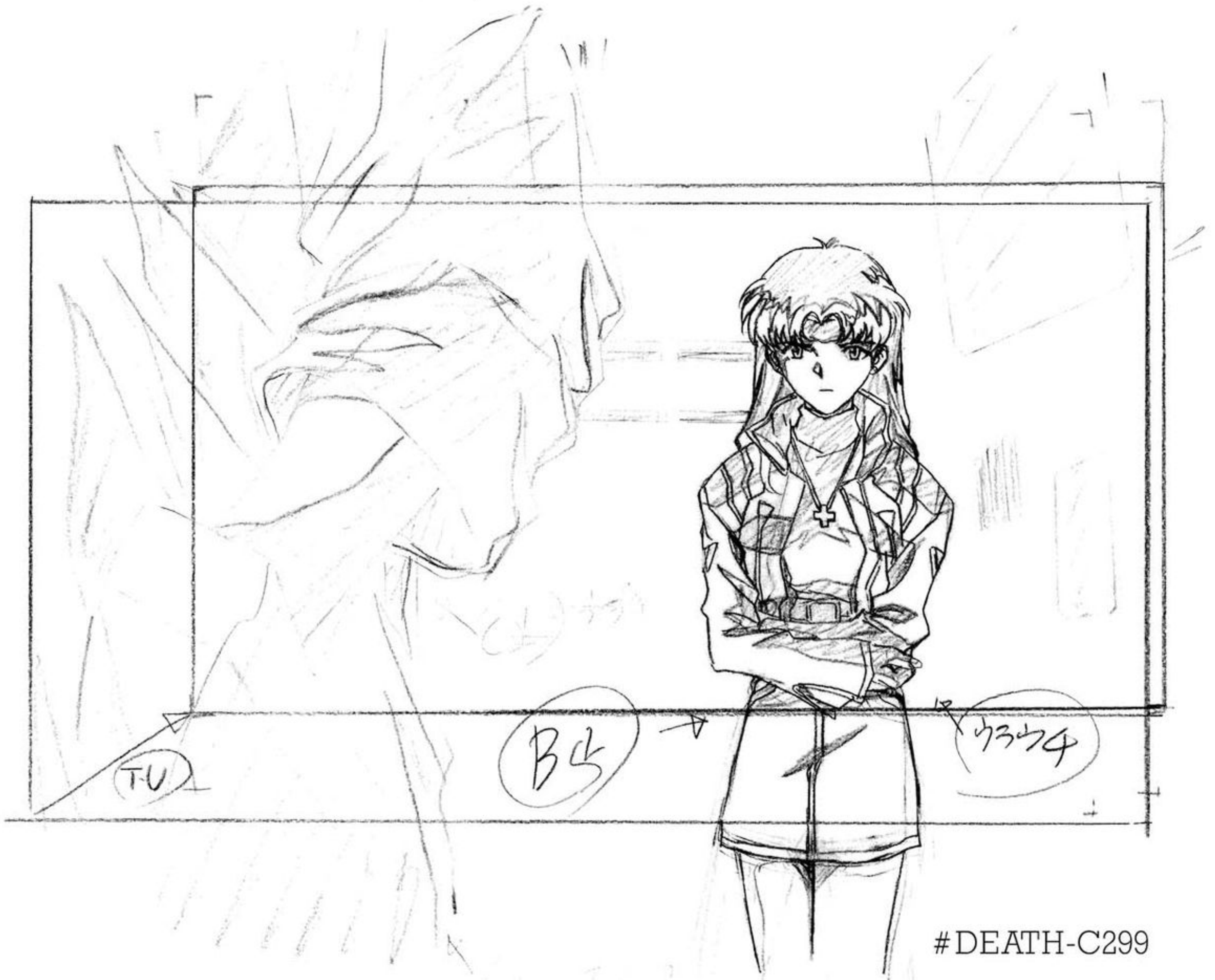



#DEATH-C300

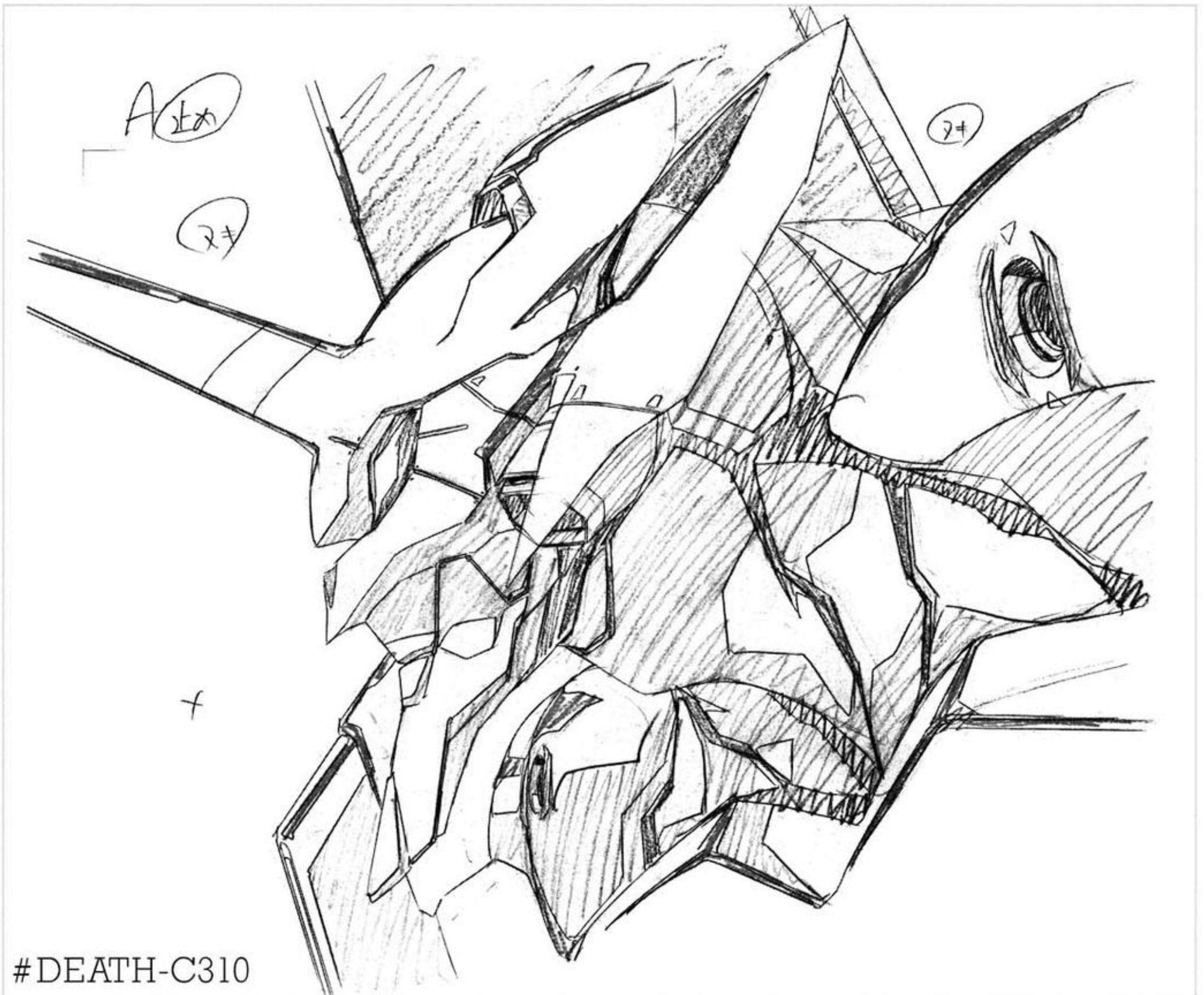

#DEATH-C310





#DEATH-C369



D2



D1

#DEATH-C370



A1 全修

BL





#DEATH-C373









#DEATH-C380

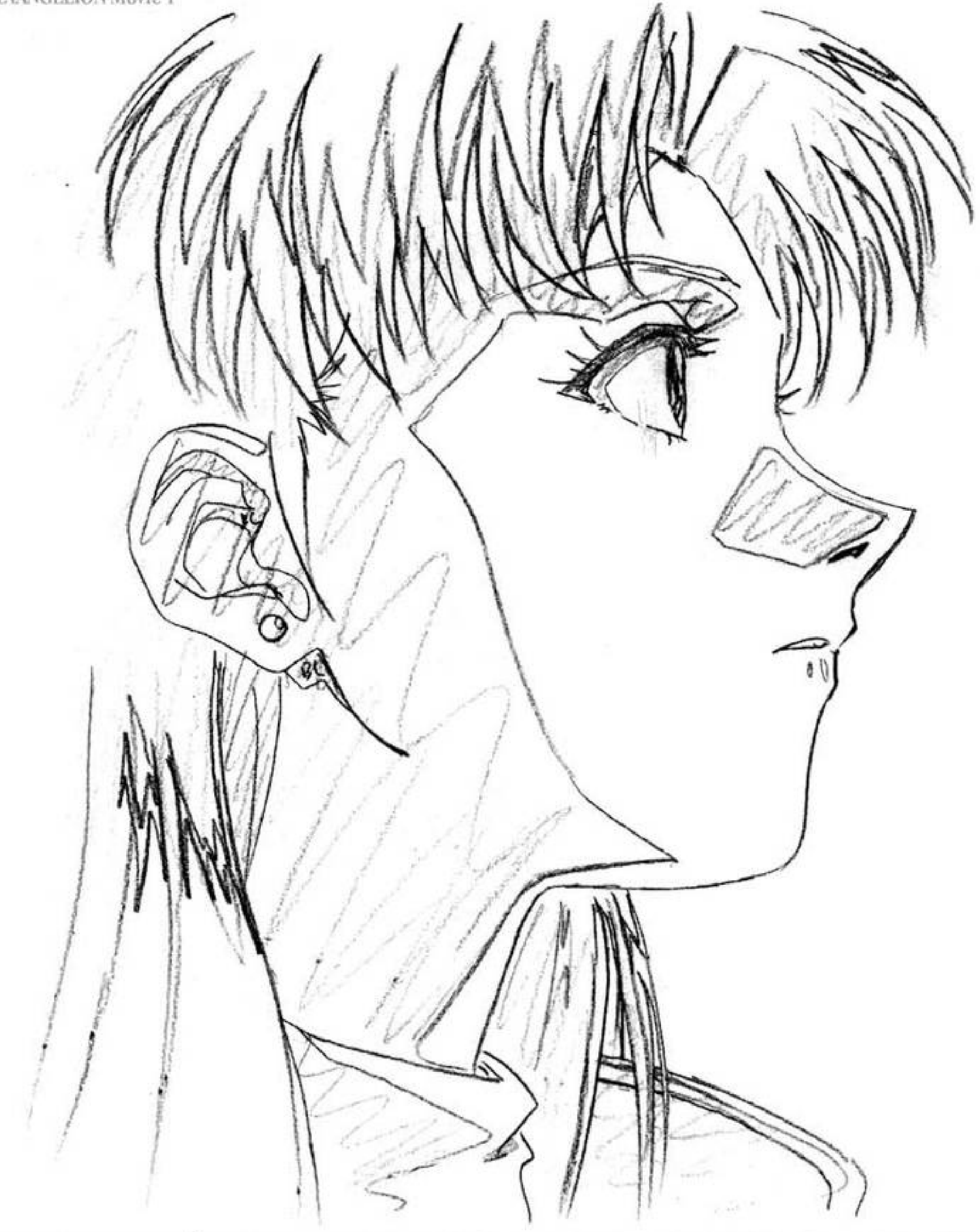

A0)



(A2)

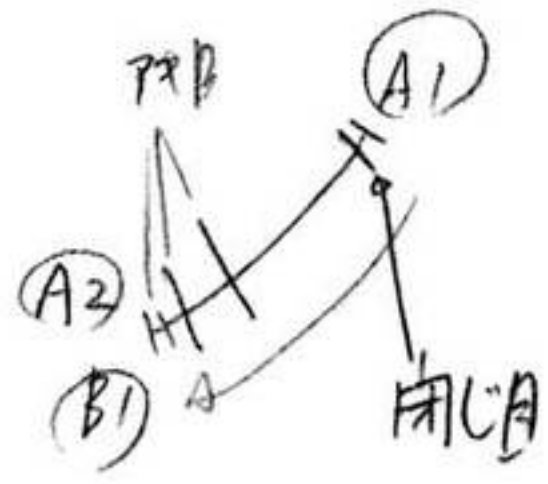

目・マコ鼻かたかみの毛服(B1)



C/62

アノイノ足



ほんとに見えない  
首が下はブルーの  
お洋服なのよ

「アノイノ足」

C/64

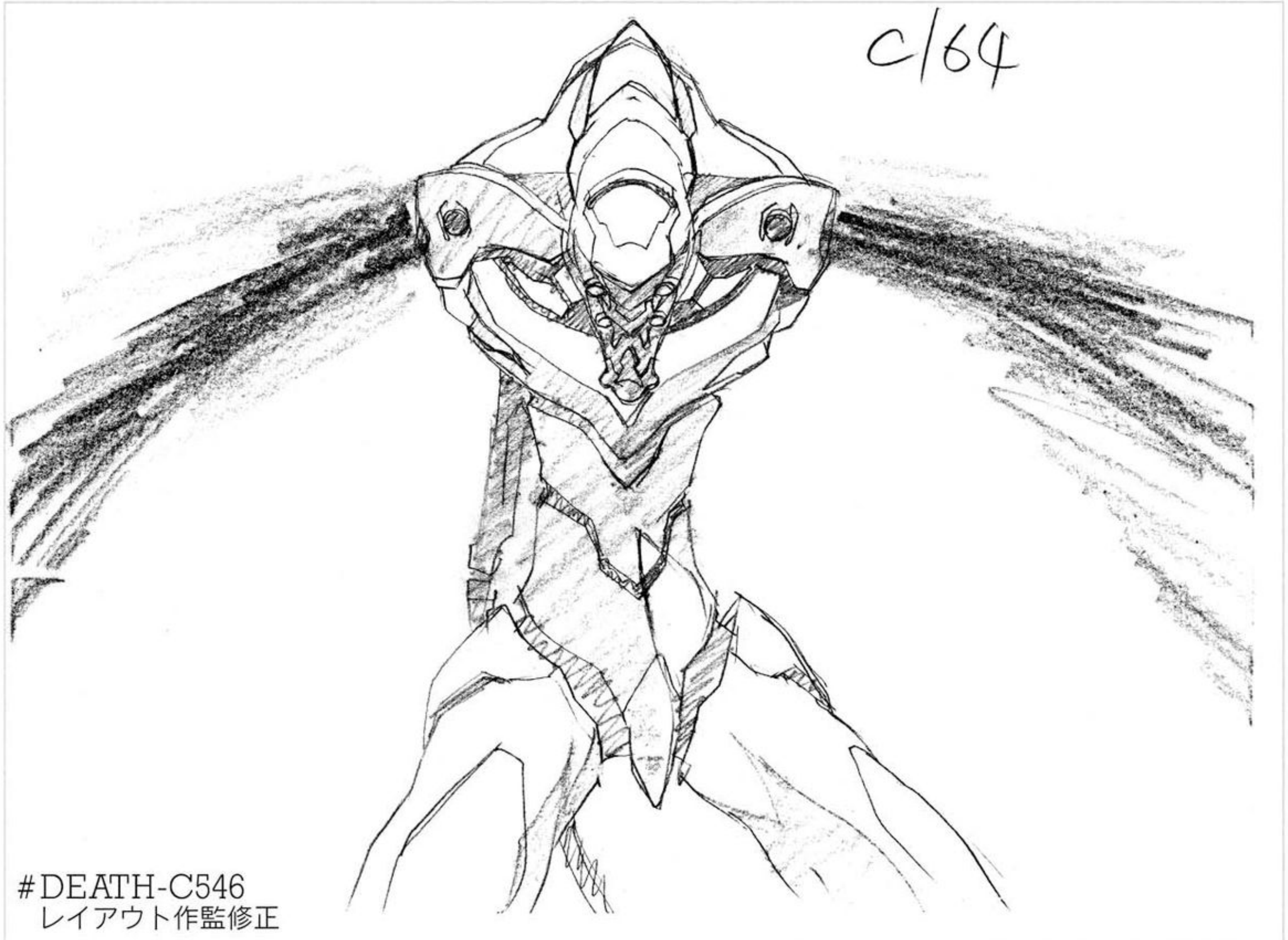



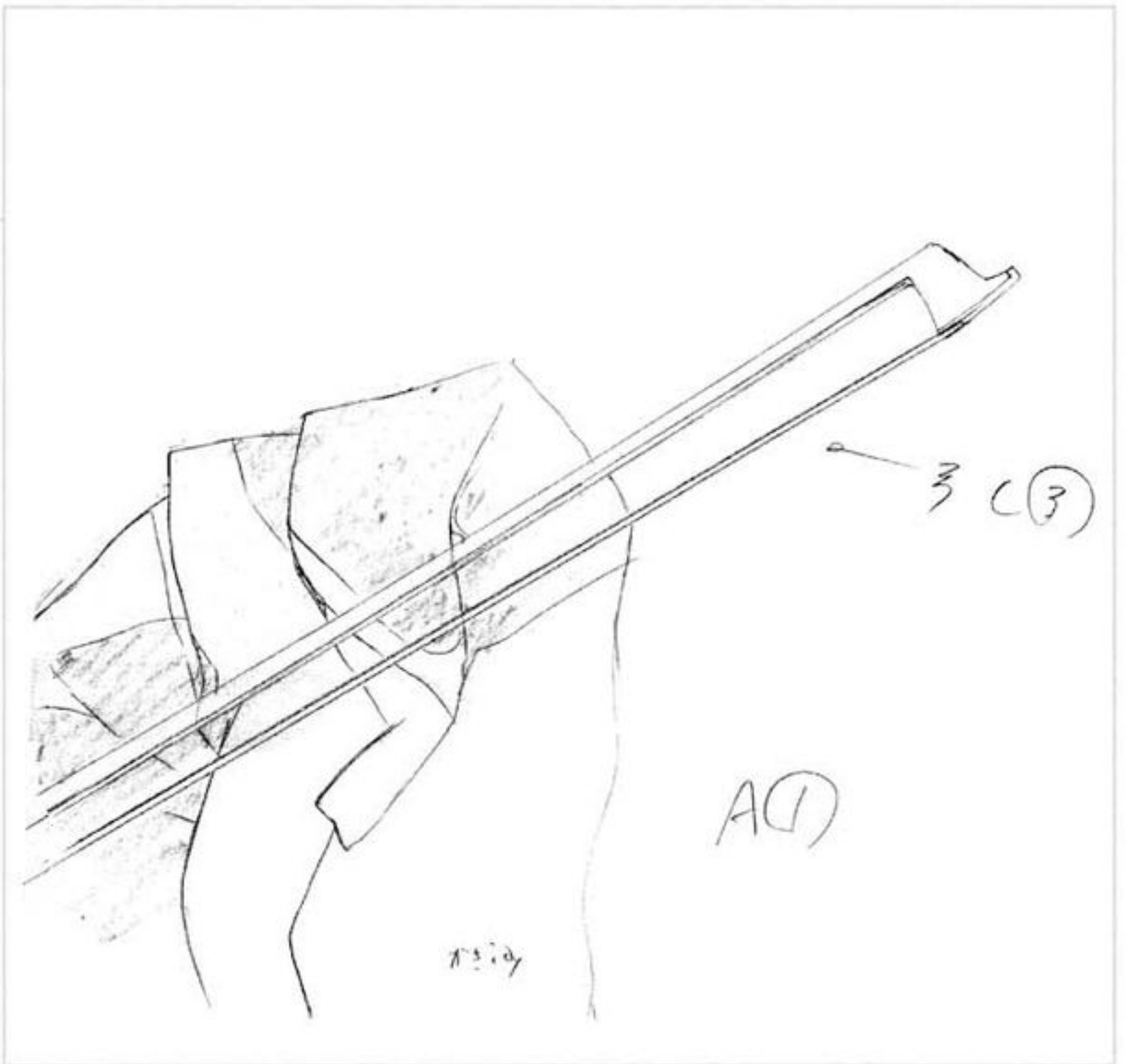

#DEATH-C572



C. 572





AG

他BX

1/2

#DEATH-C680



B4 and

他B2

AI  
かたはら



B3

他B2  
1/6

AI  
かたはら



#DEATH-C1210

B2

AI  
かたはら

アタカ  
17





#DEATH-C708

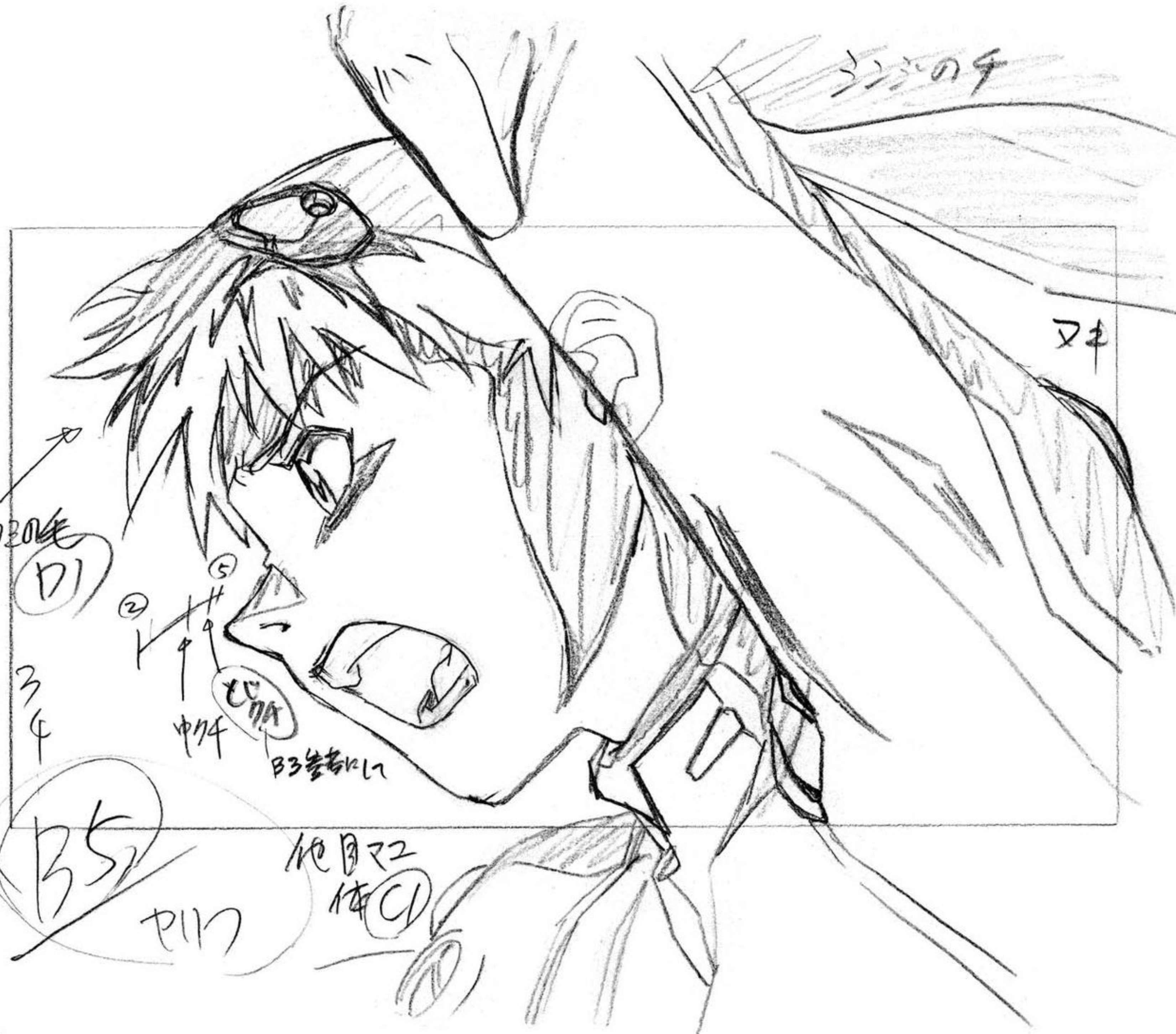







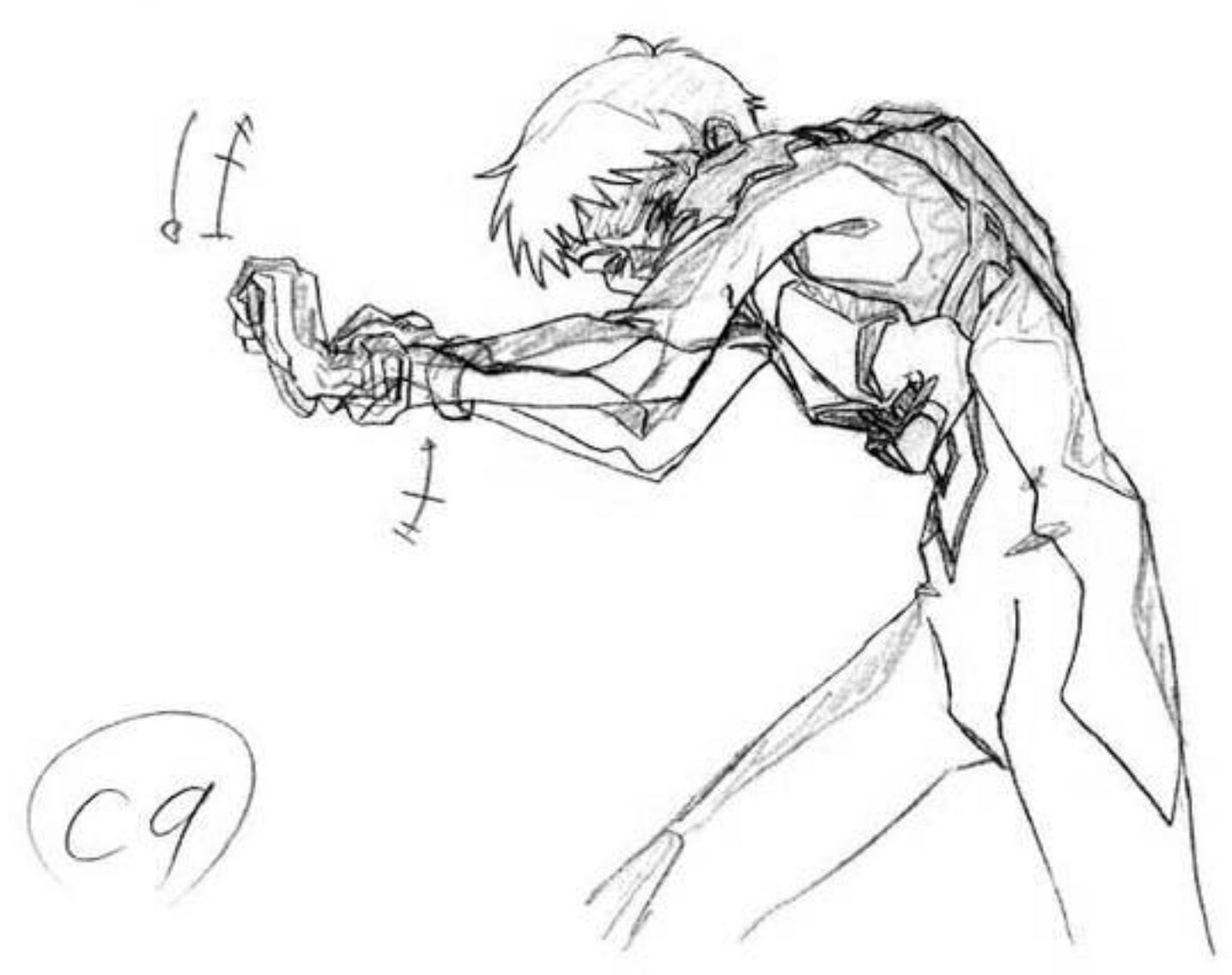
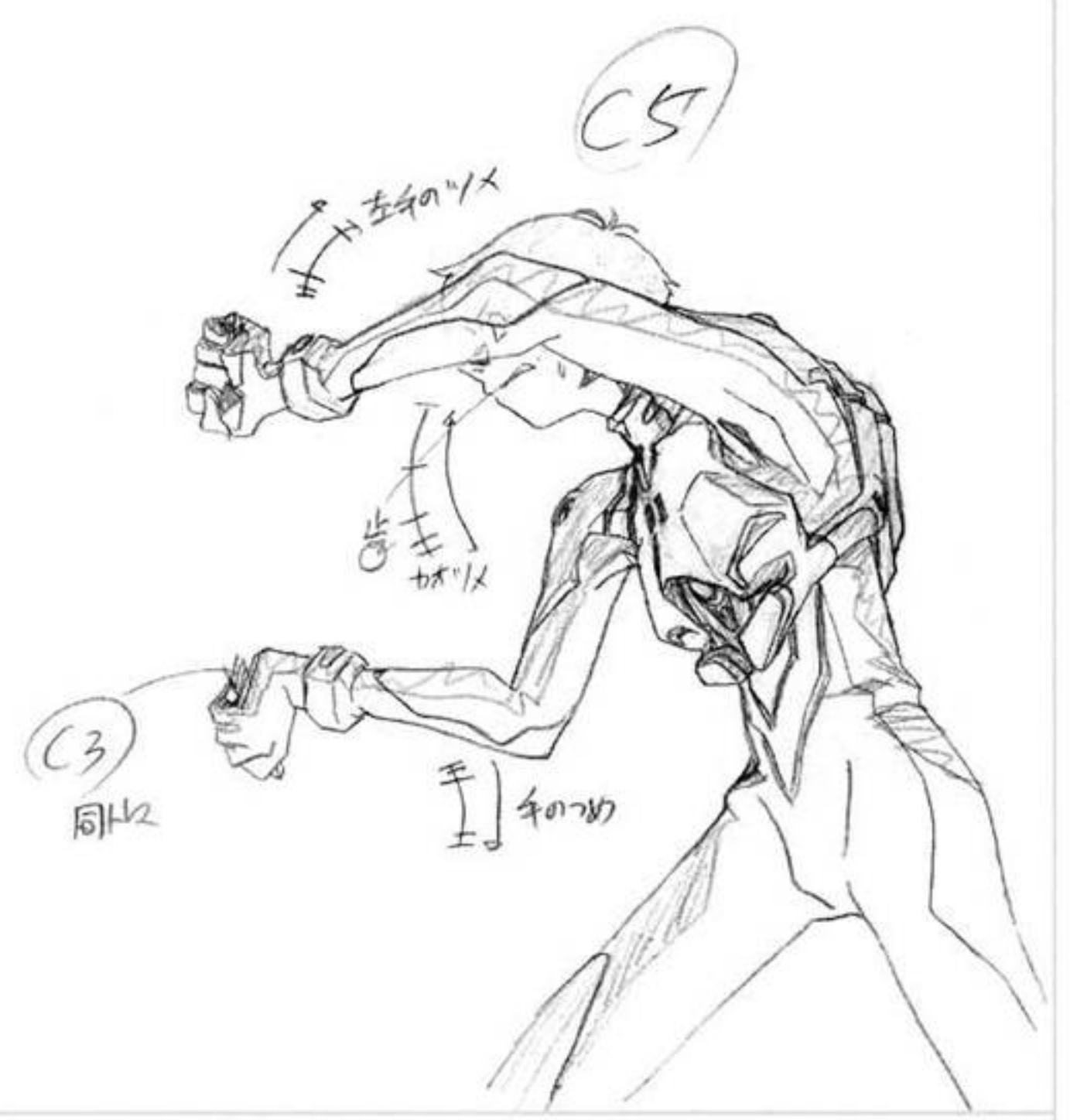



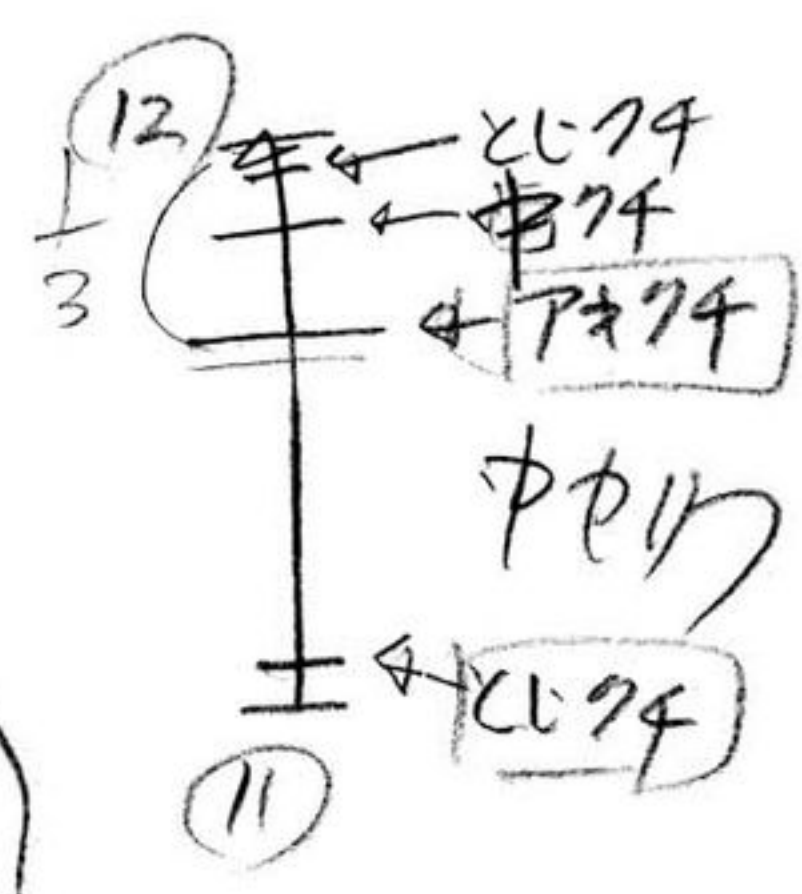
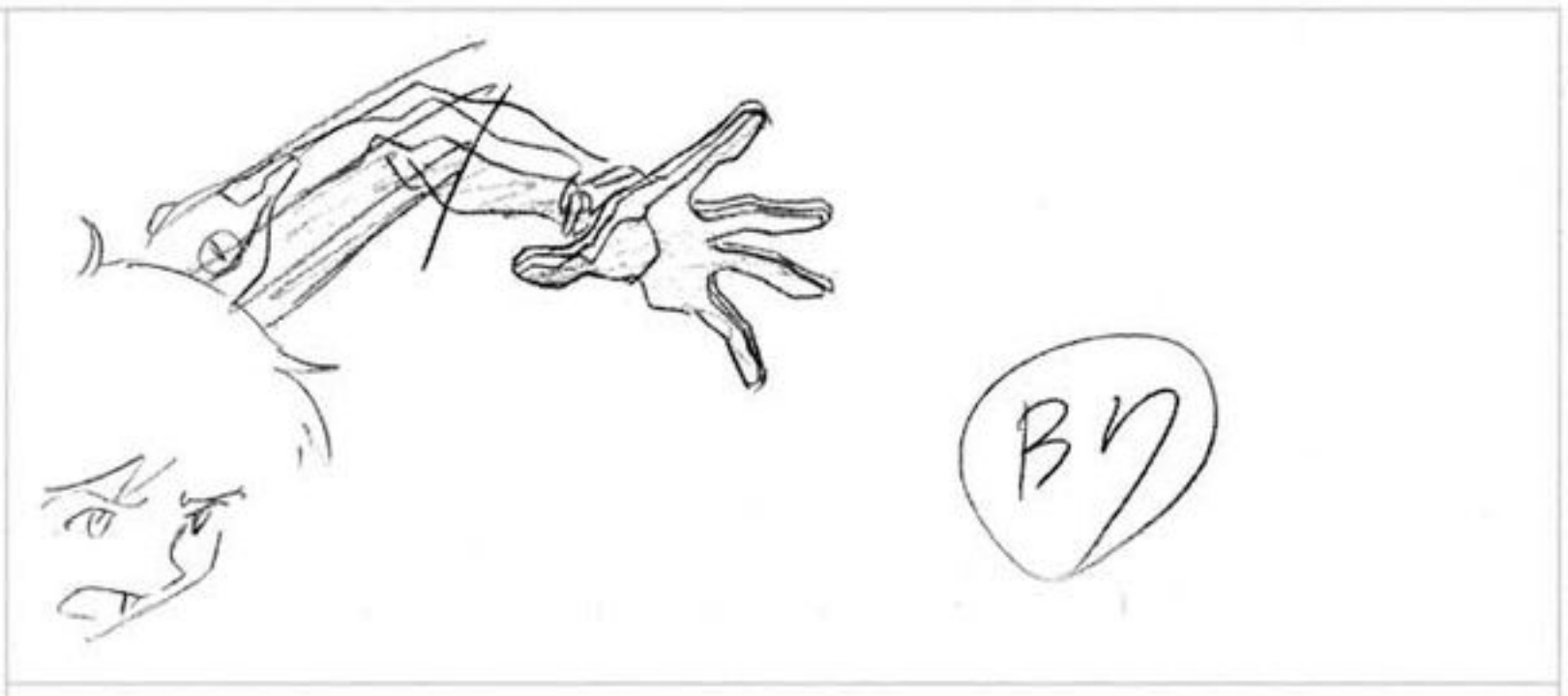

★ 中割  
C74





#DEATH-C717,721

マコは  
カミモの下

目マコ  
カミモの下  
カミ C3





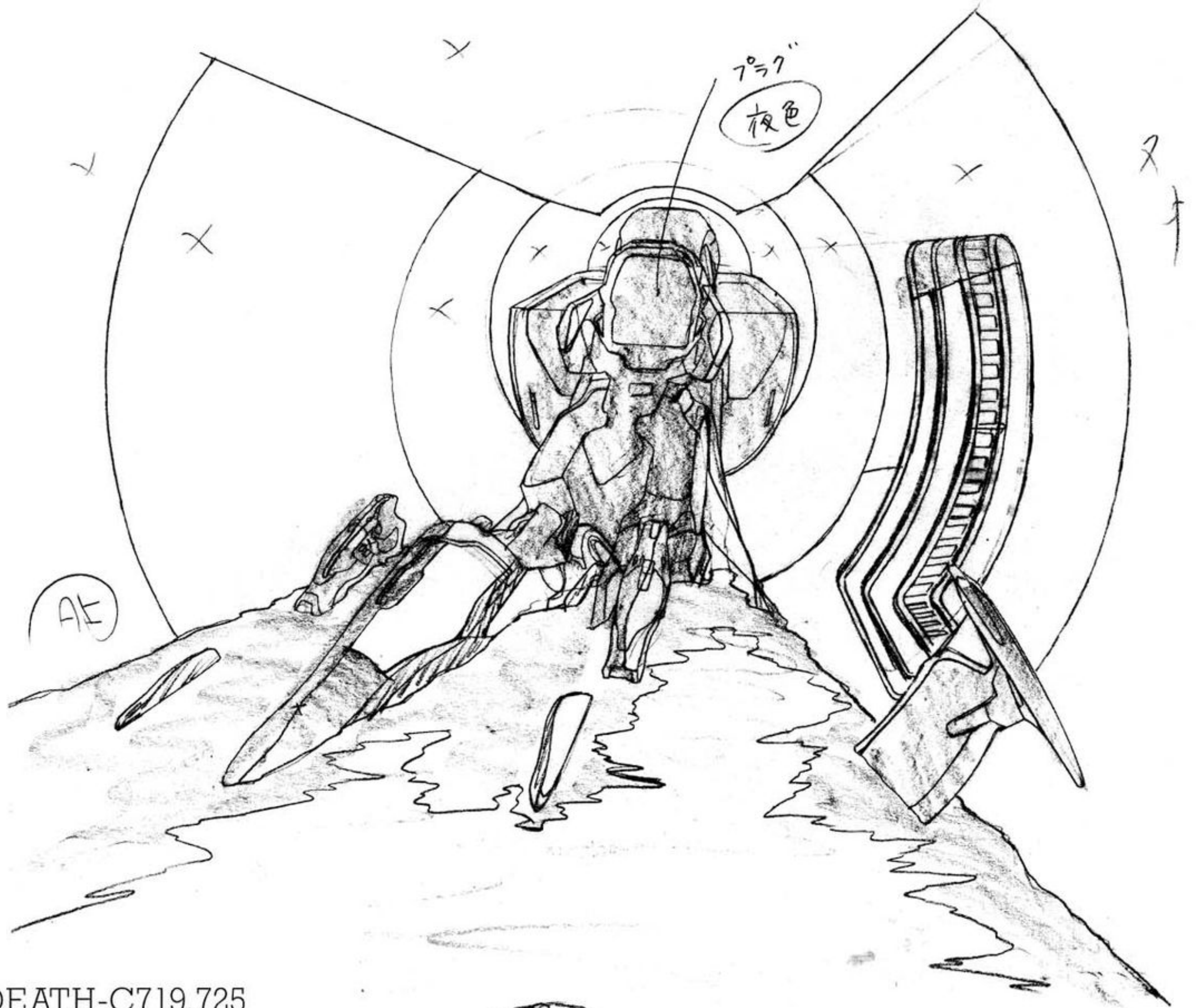

#DEATH-C719,725



#DEATH-C719,725

LCL+10 (中のP12.7)







# DEATH-C726

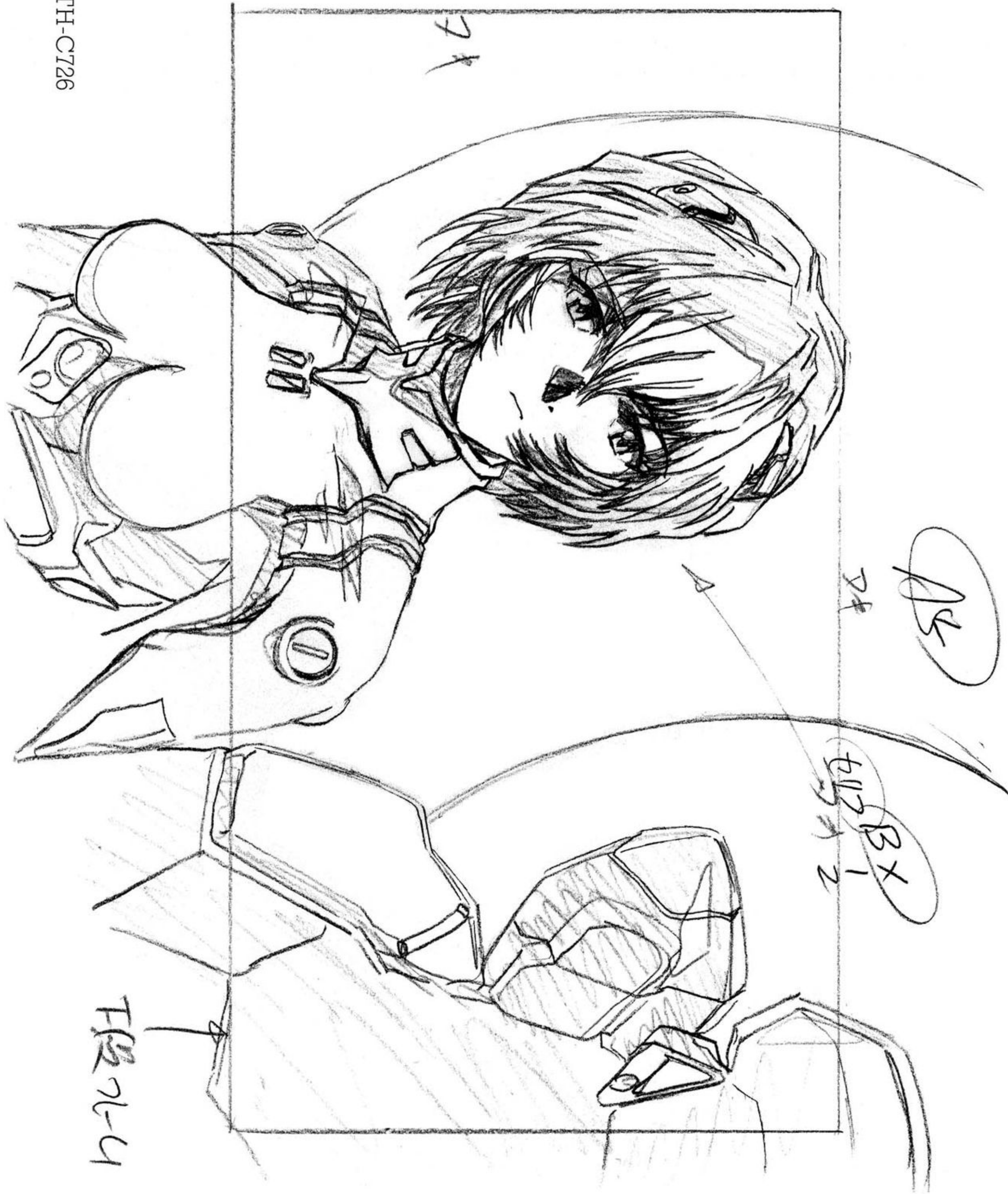



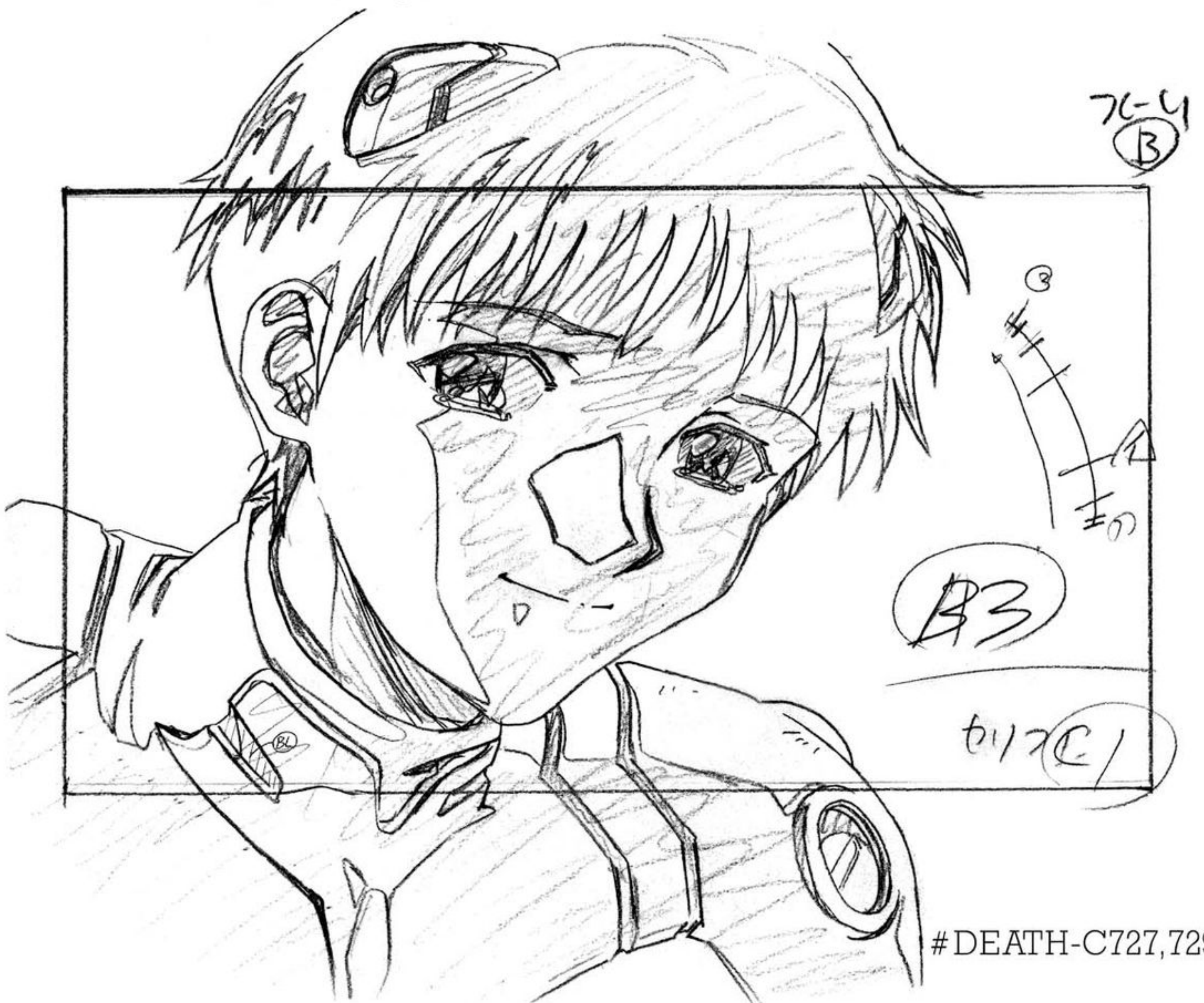

#DEATH-C727,729





B1

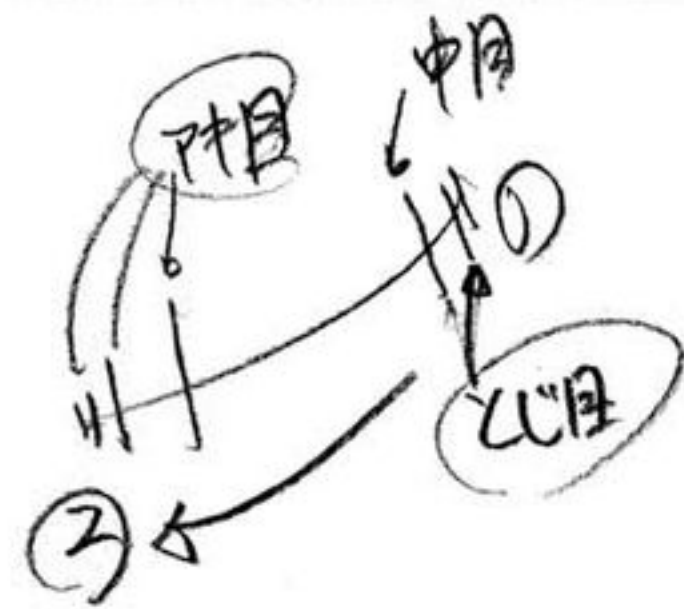

B2

た117 (C1)

↑  
FG2/004





AL

4334



#DEATH-C731



AL

#DEATH-C733





B1

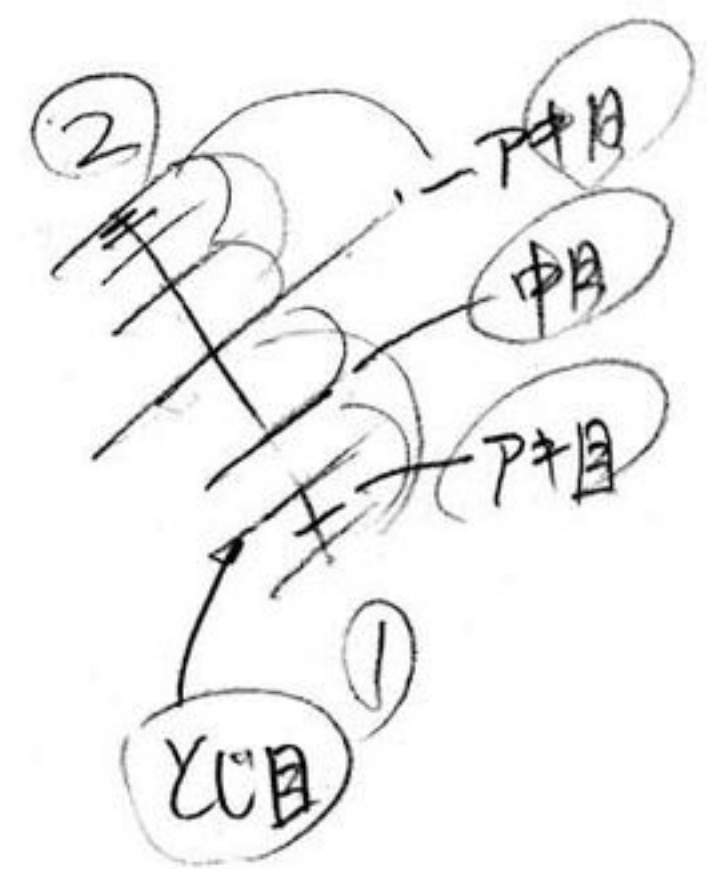

B2

中目ハナ





#DEATH-C734





AD





#25-C022





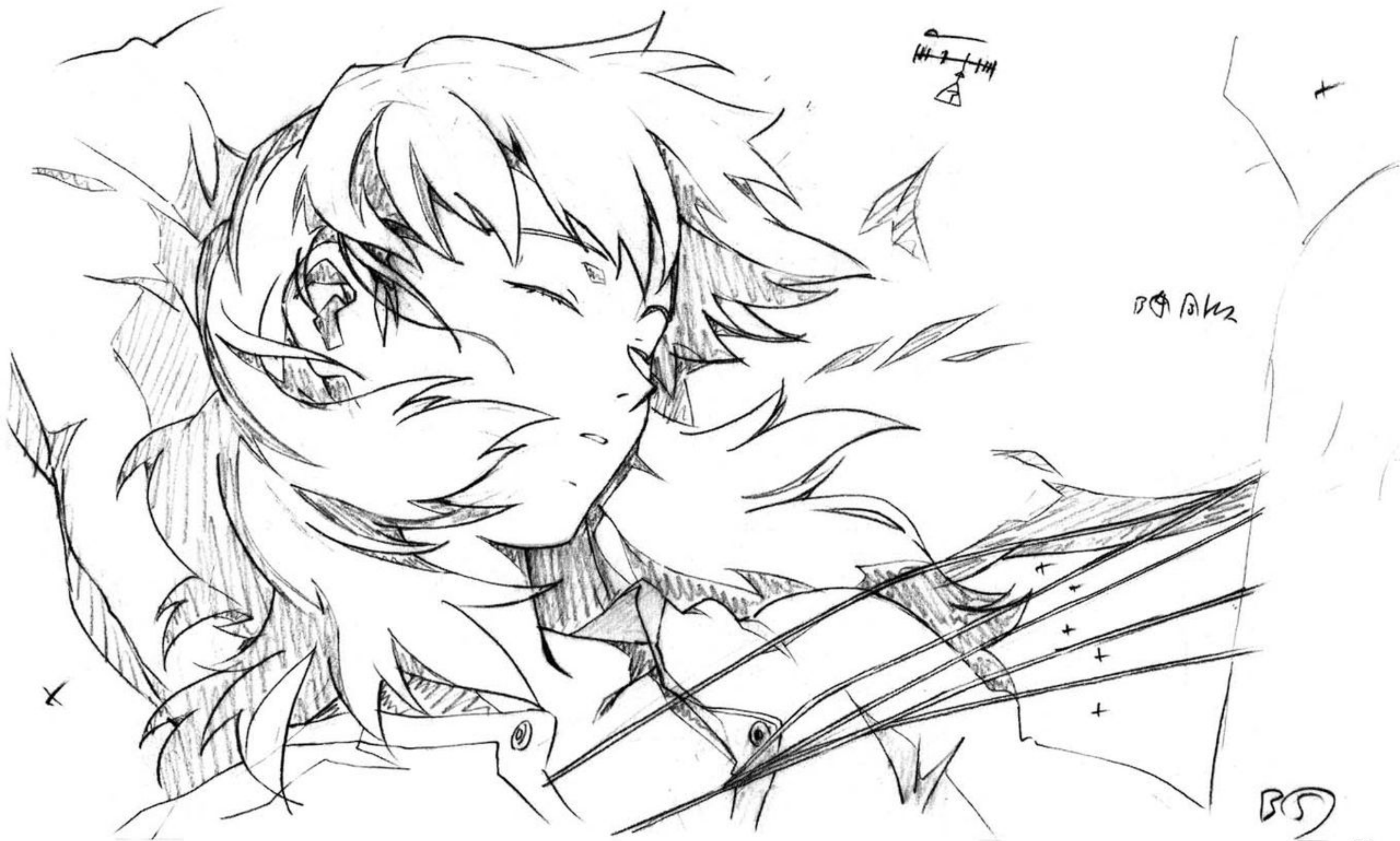



#25-C023

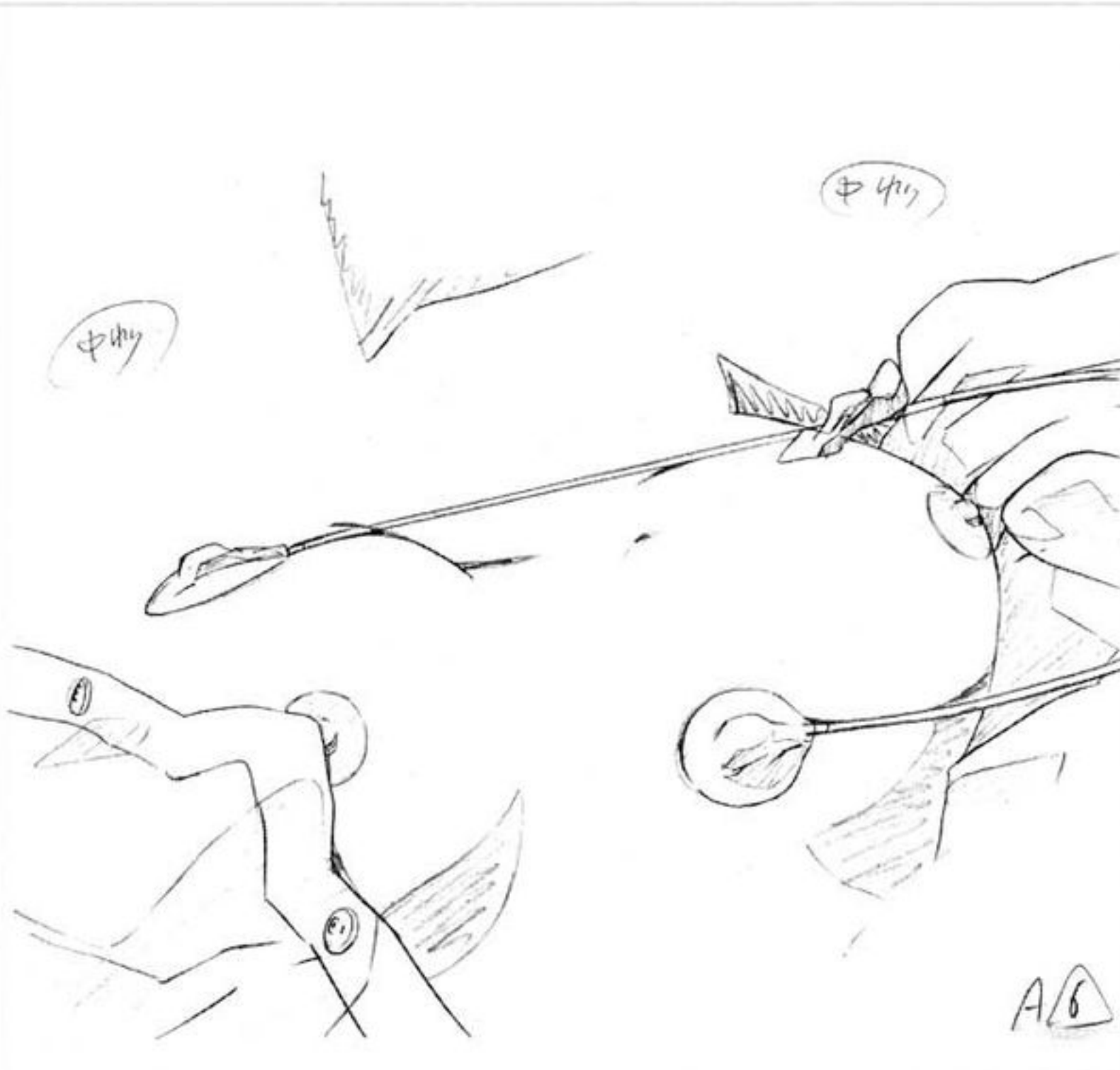
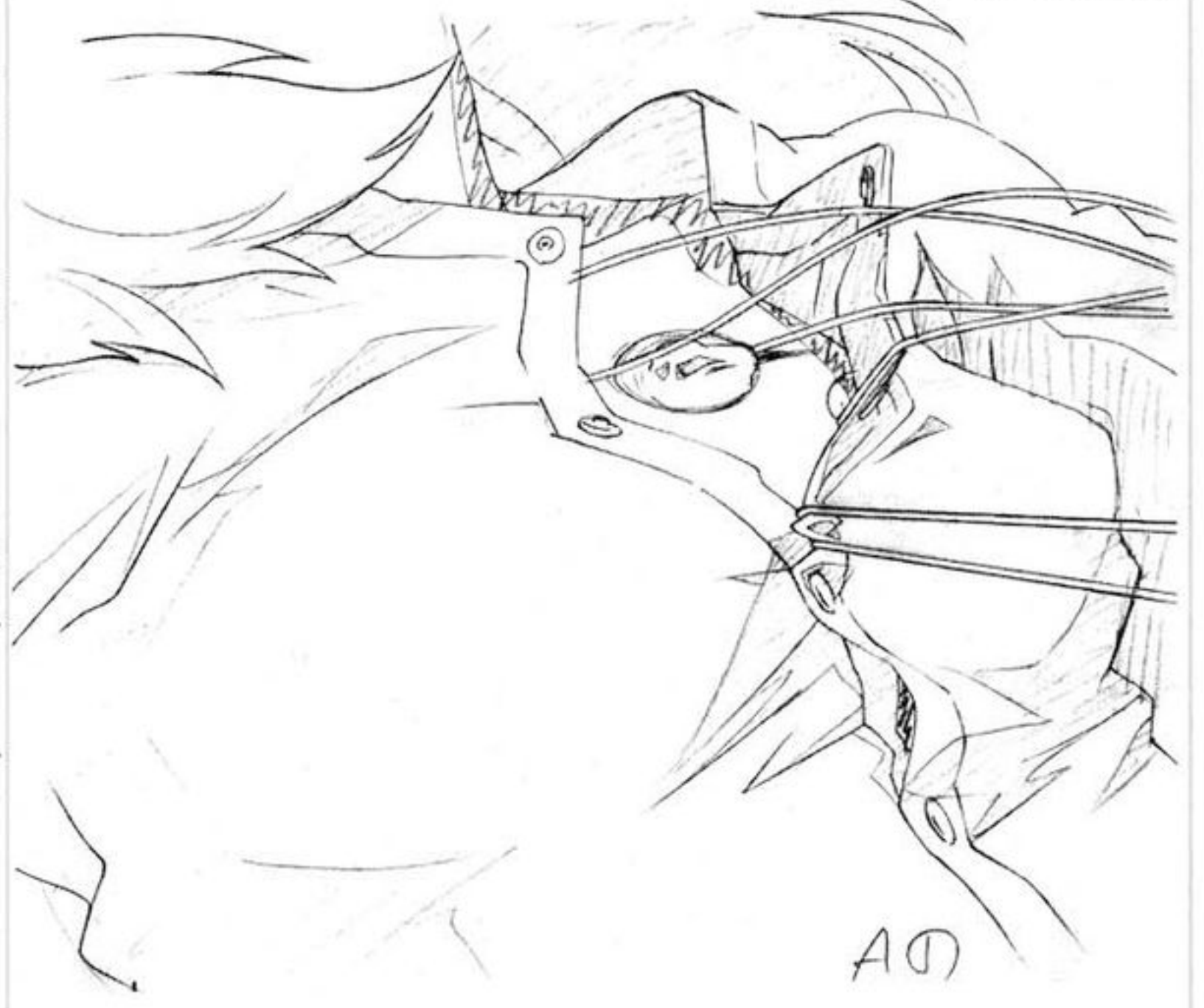
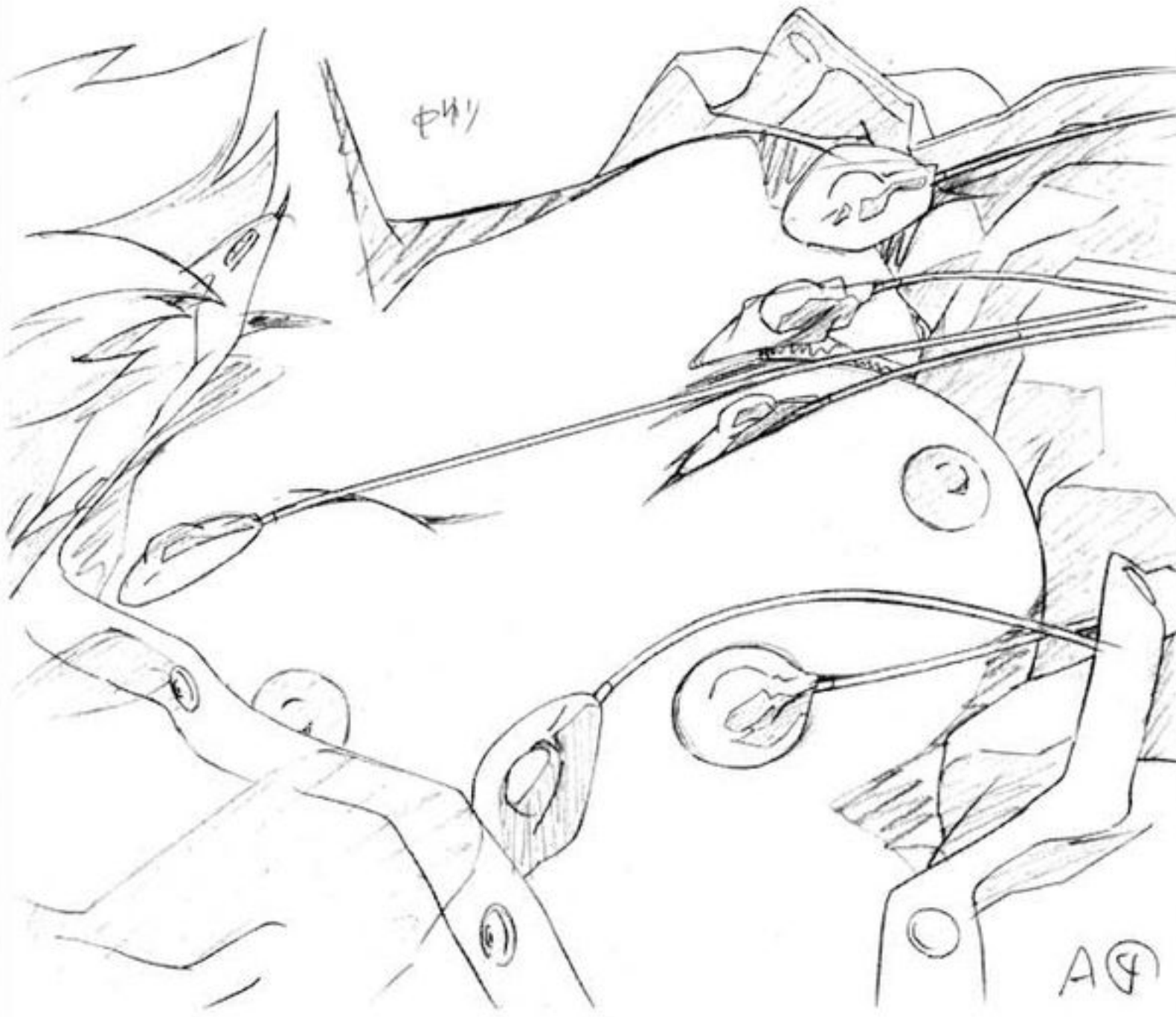



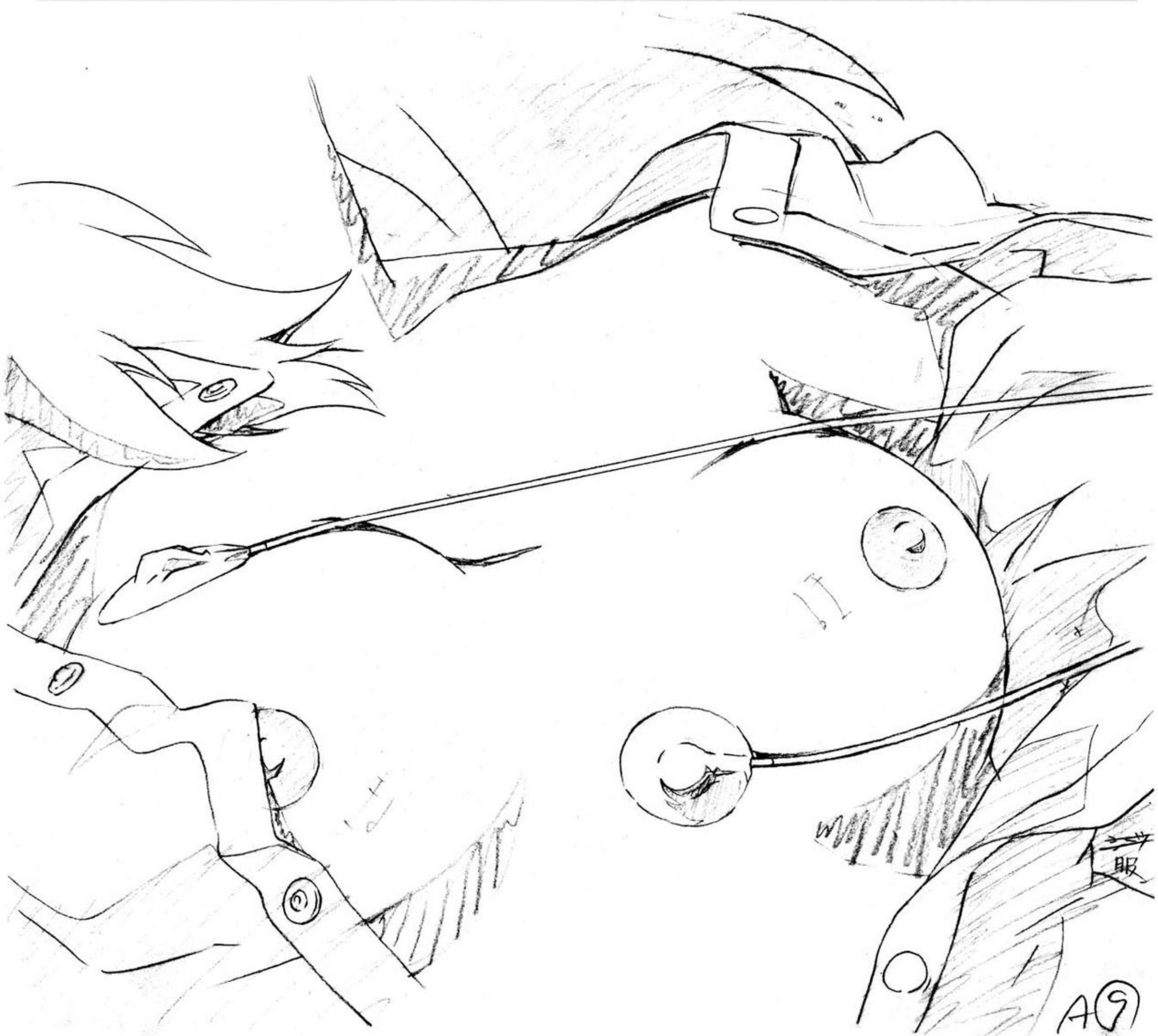
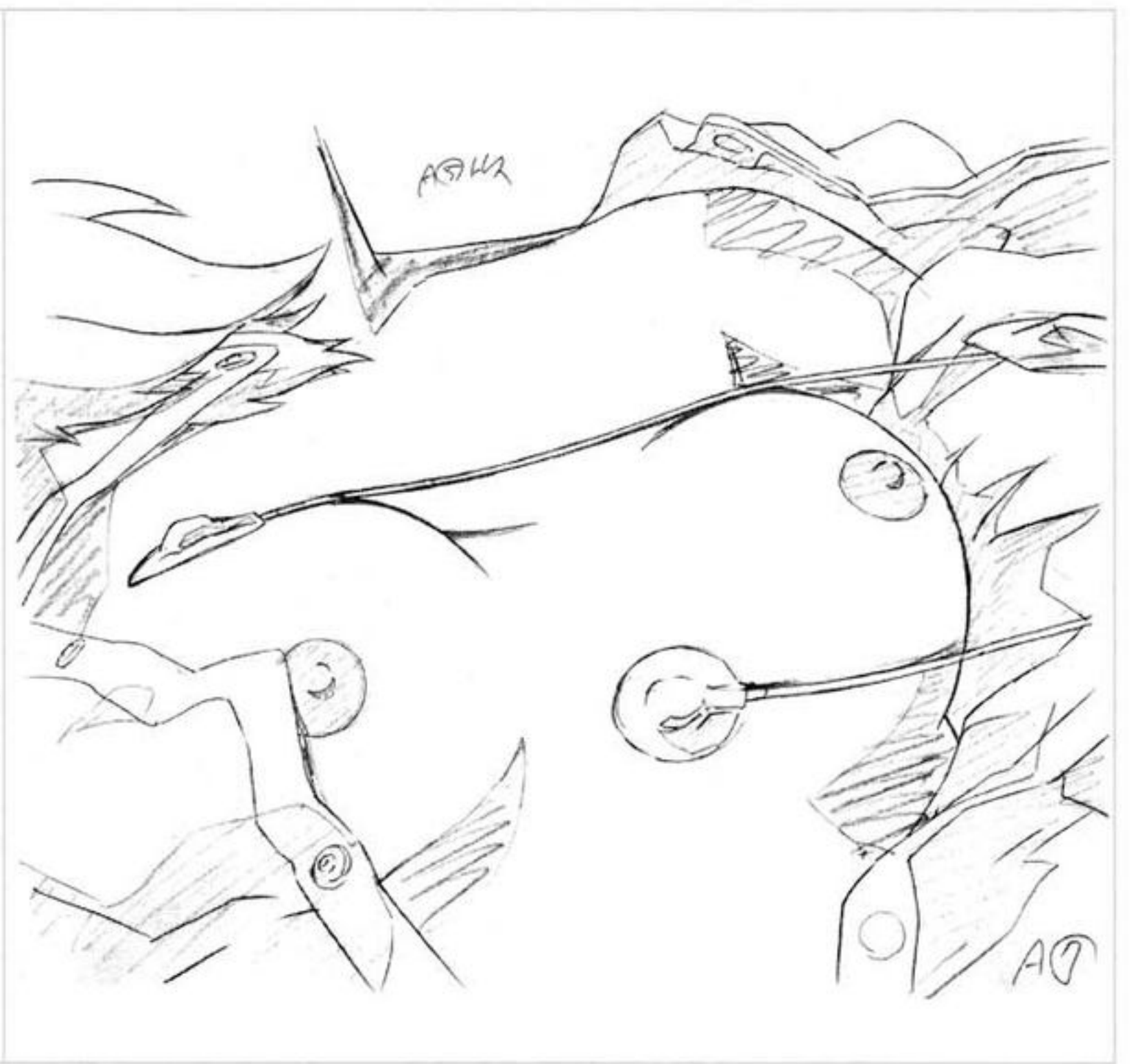
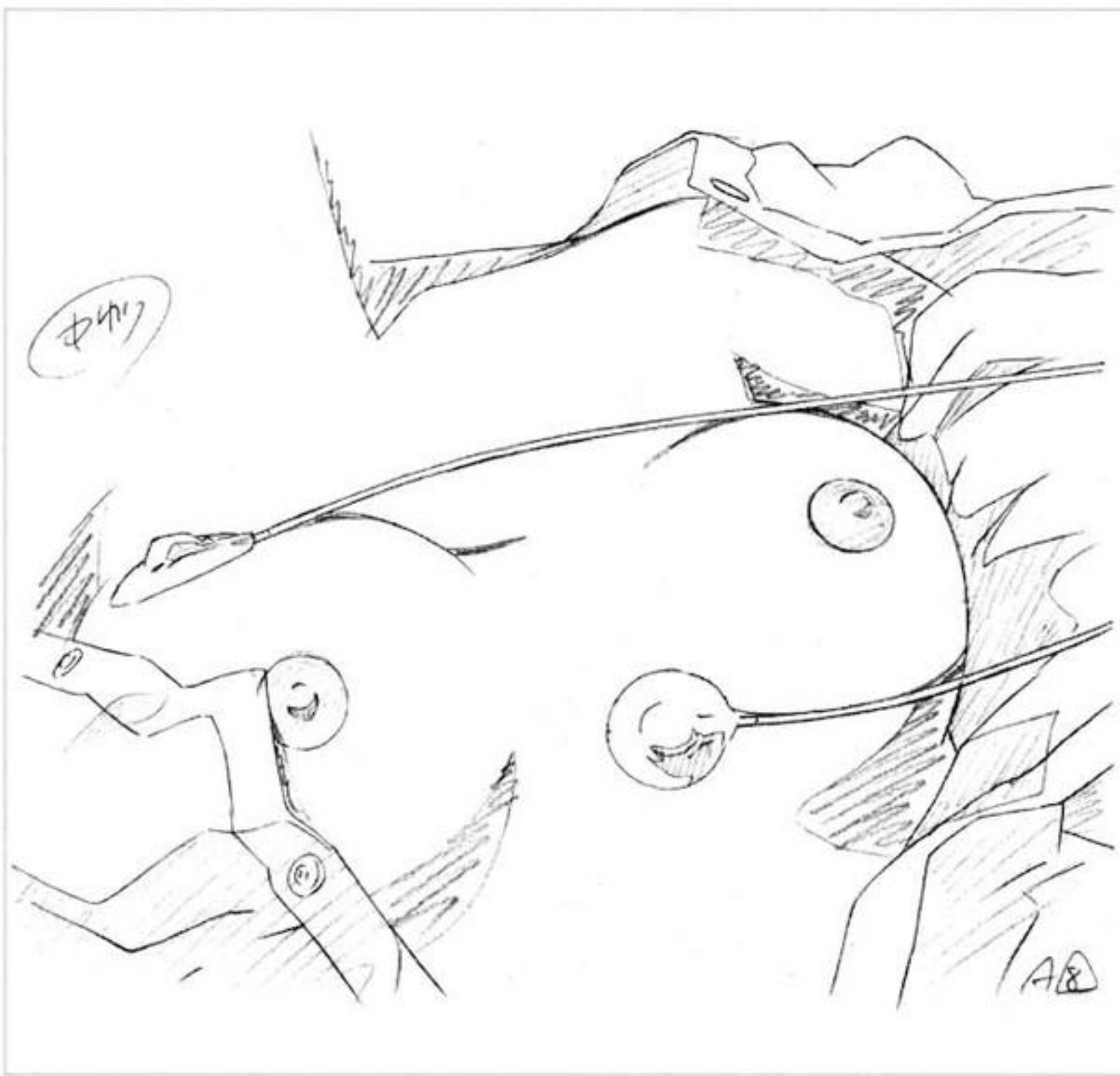



A9



#25-C026



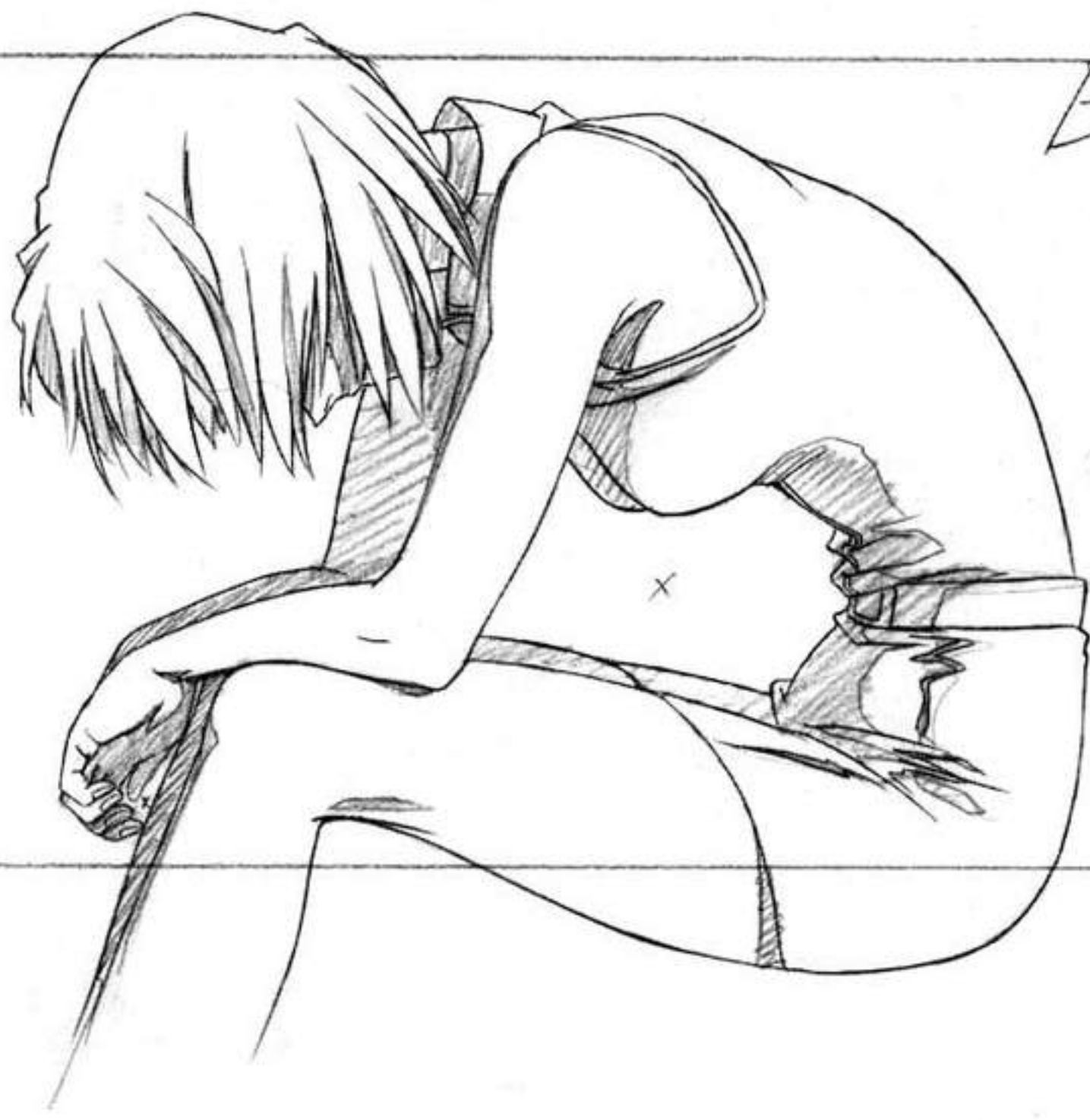

B/D  
117  
C(2)34

x = 又キ

#25-C085



修正原画

修正原画

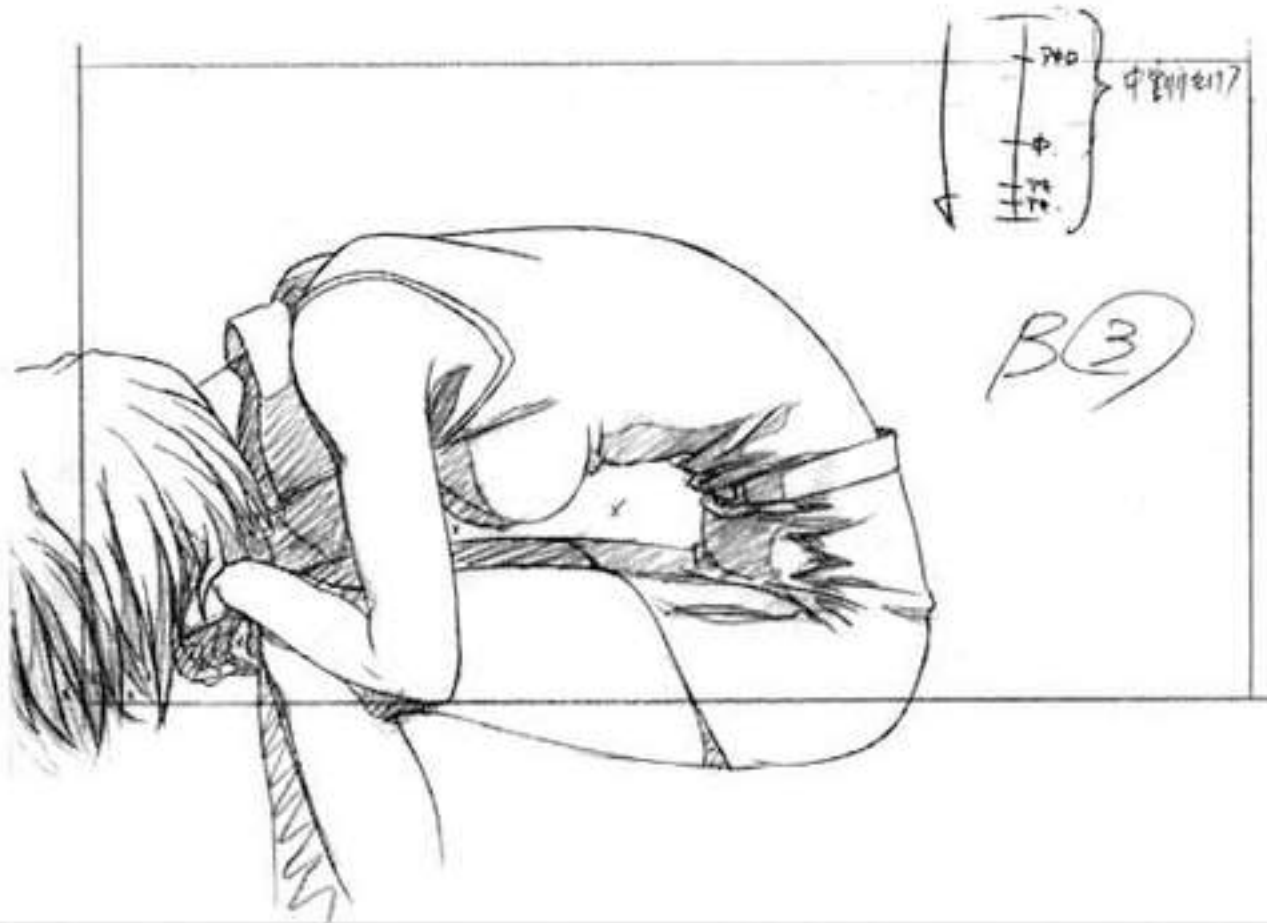

B(3)



B(2)

修正原画

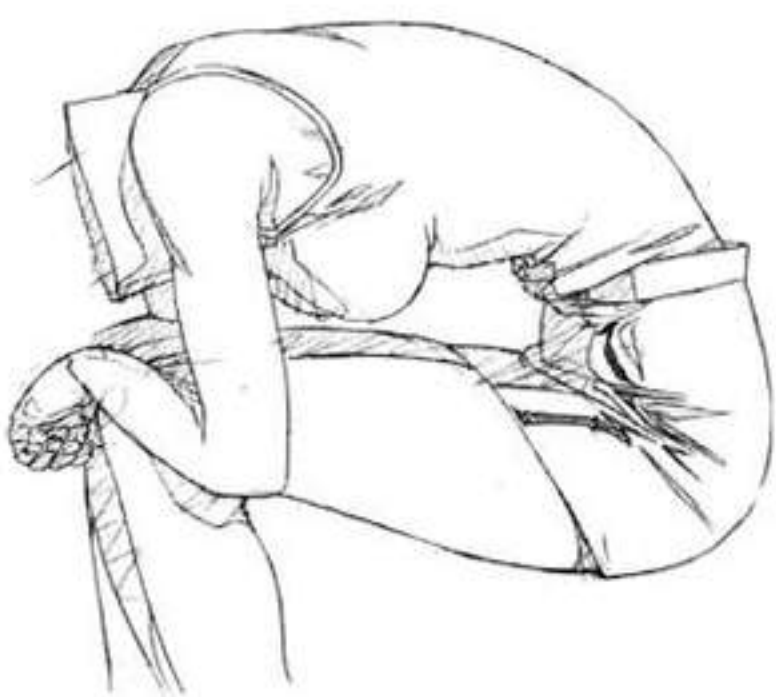

修正原画

修正原画



修正原画



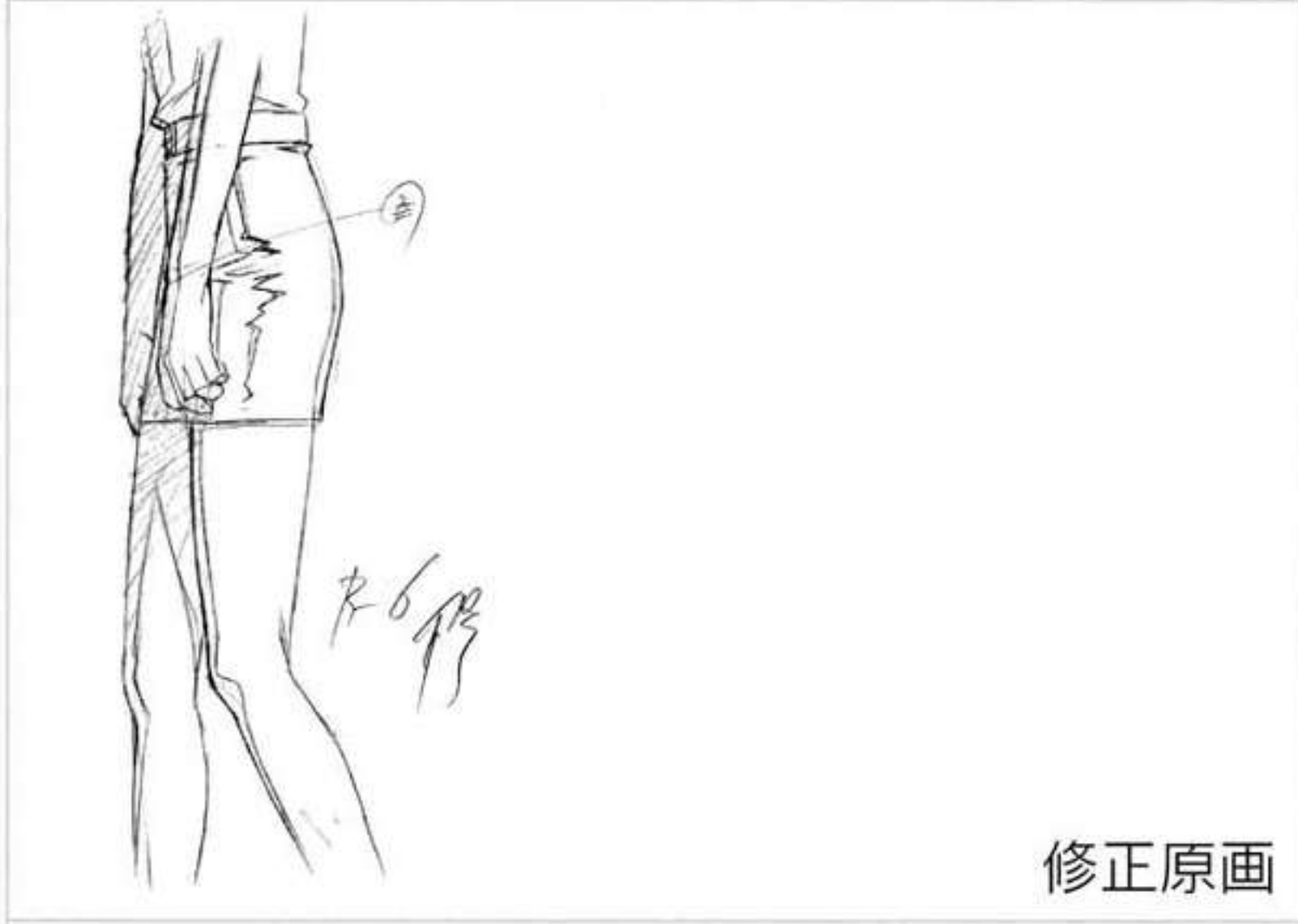
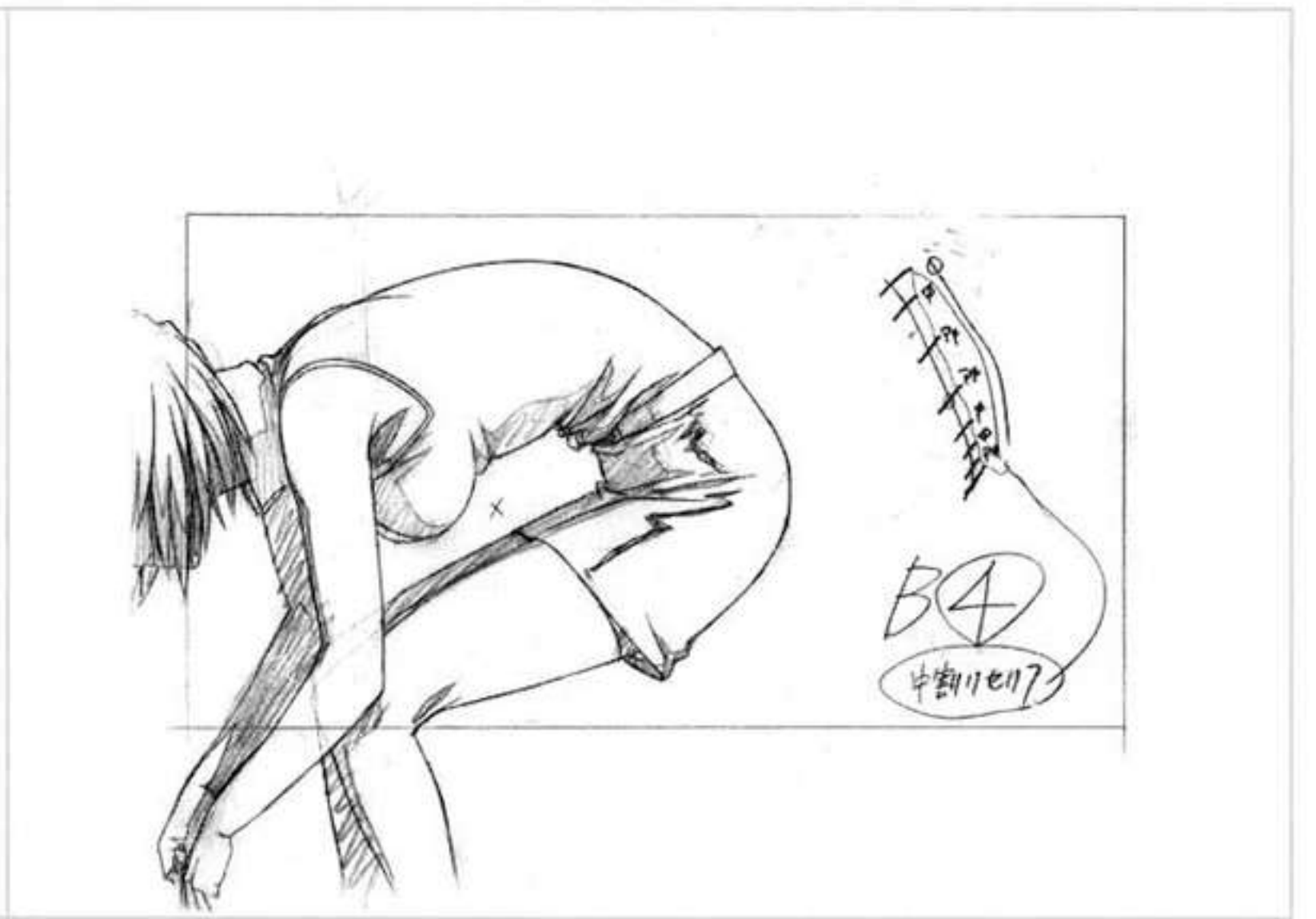
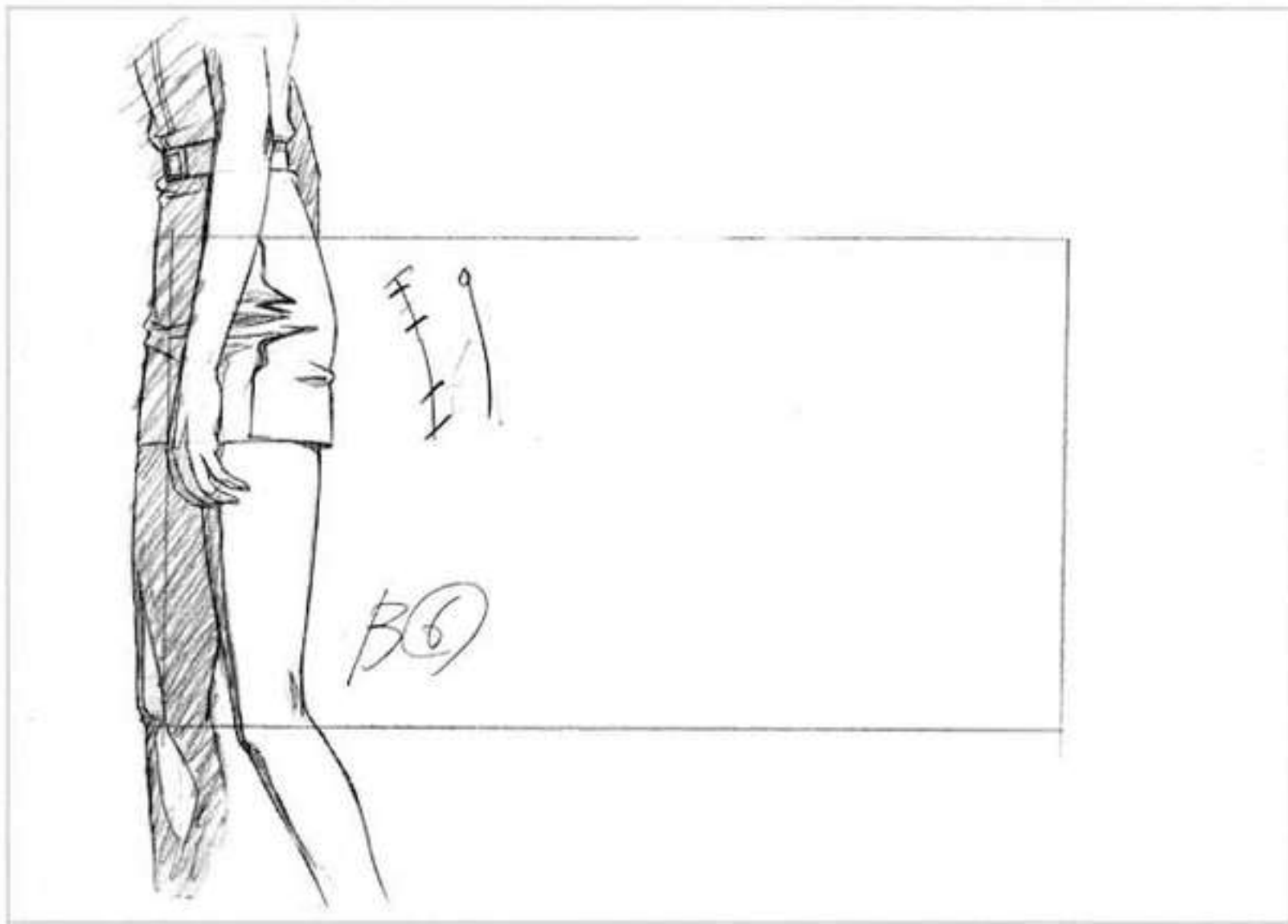

修正原画

修正原画

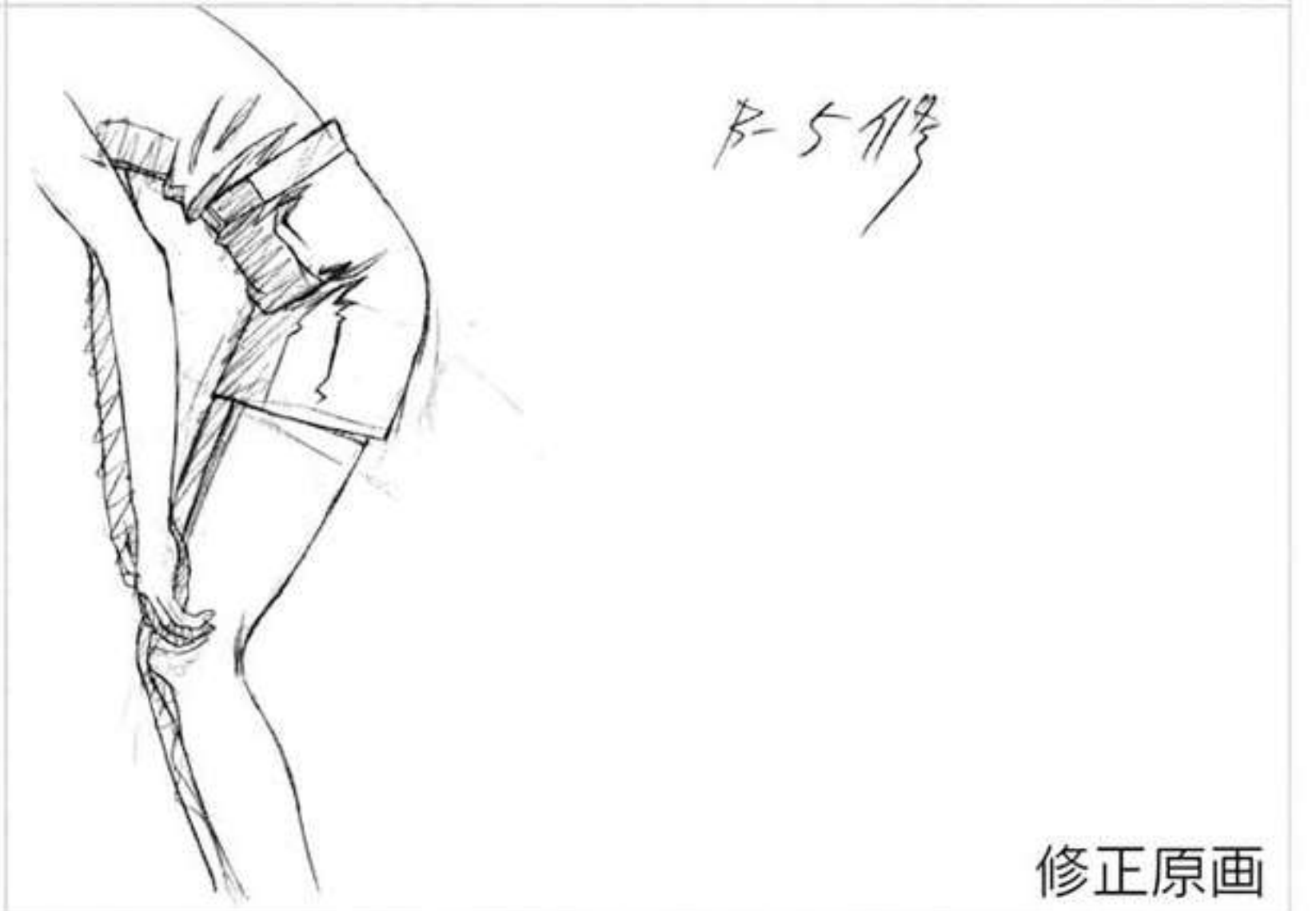
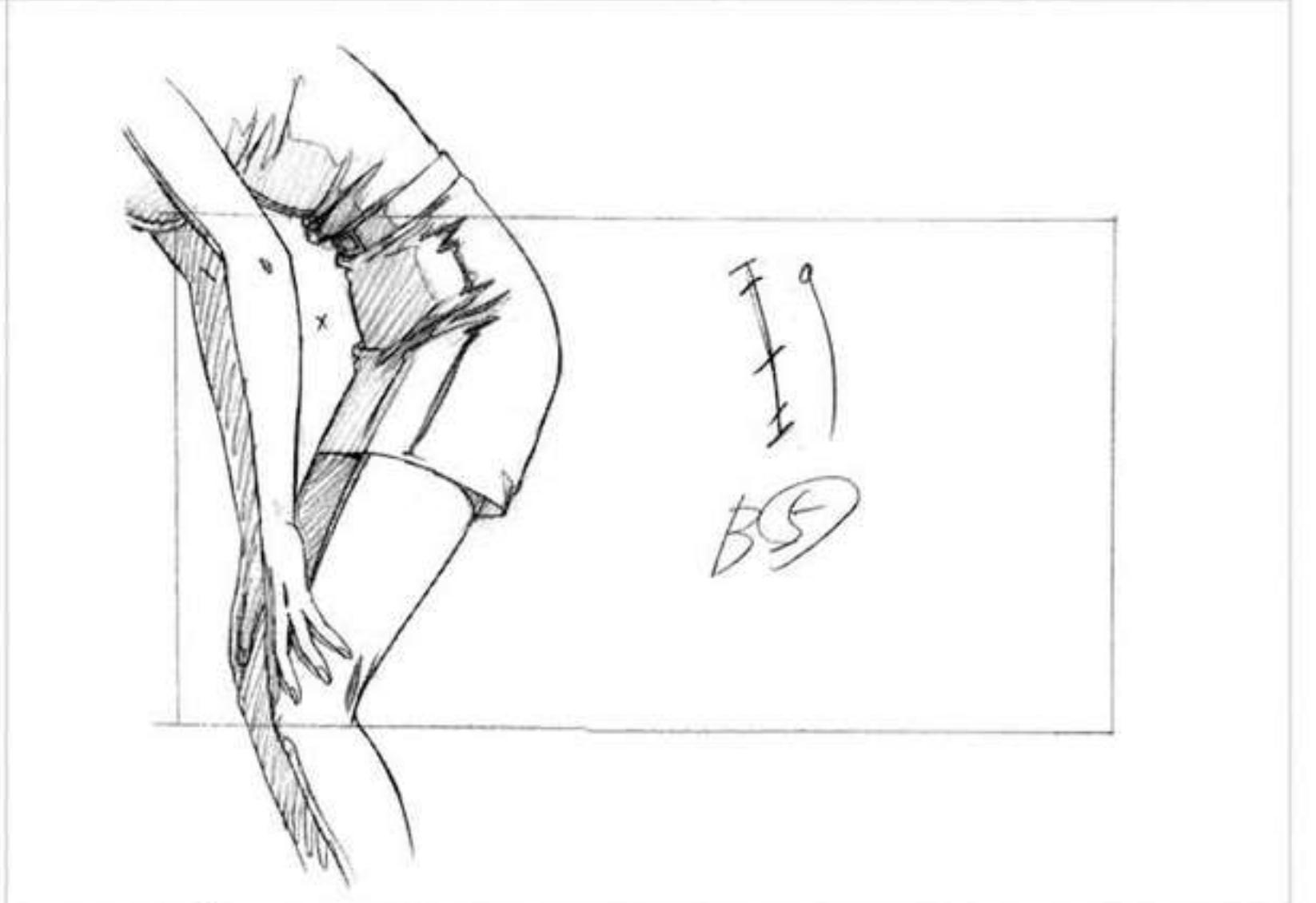
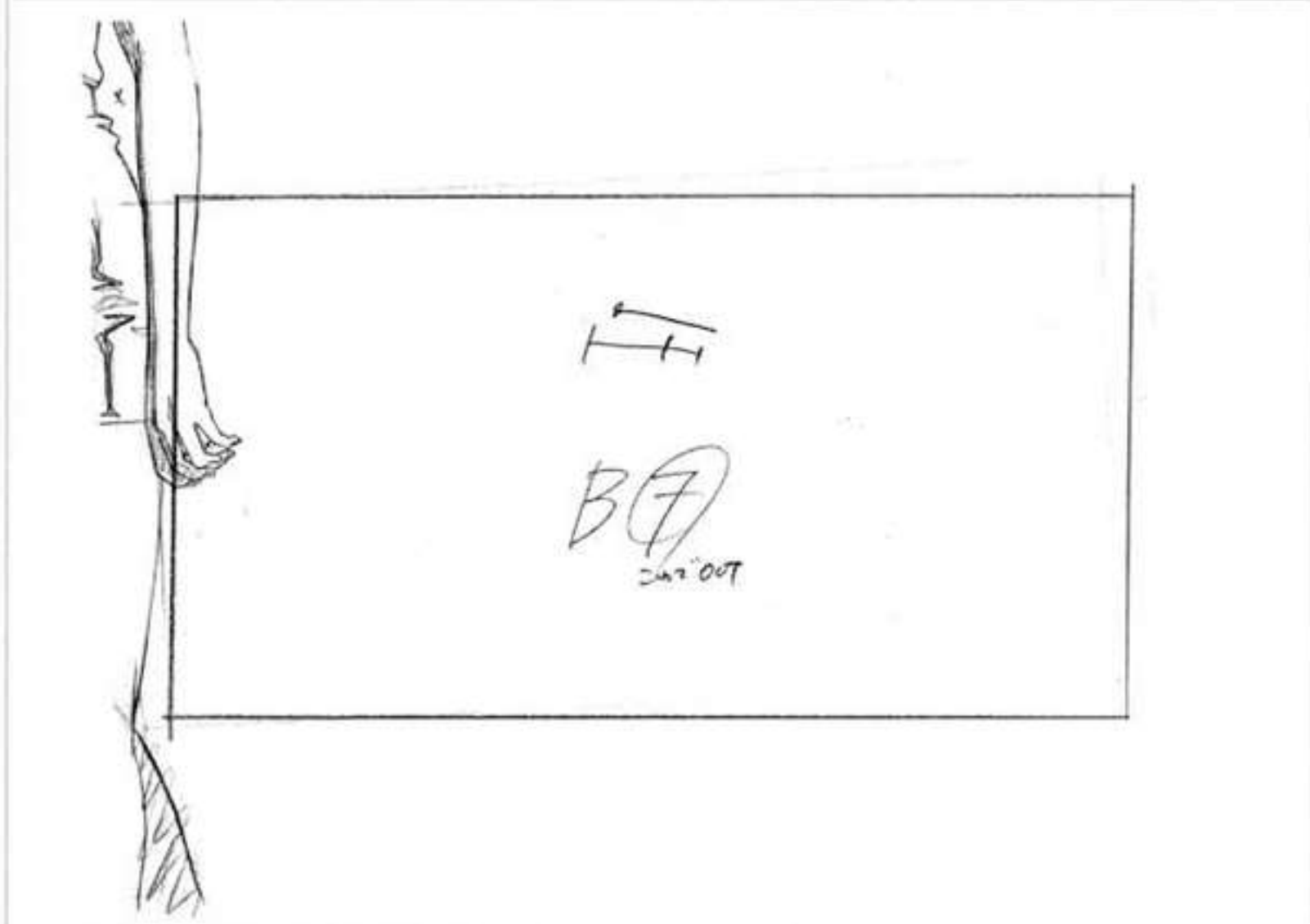

修正原画

修正原画





#25-C088



タイムシート

ABC	
①①④	
' / / ④	2
' / / ④	
' / / ①	4
' / / ①	6
' / / /	8
' / / /	10
' / / ②	12
' / / /	14
②②	14
' / / ②	16
' / / ③	18
' / / ④	20
' / / /	22
' / / ④	24
' / / /	26
①①④	28
④④①	30
④④④	32
④④④	34
④④④	36
④④④	38
④④④	40
④④④	42



C654

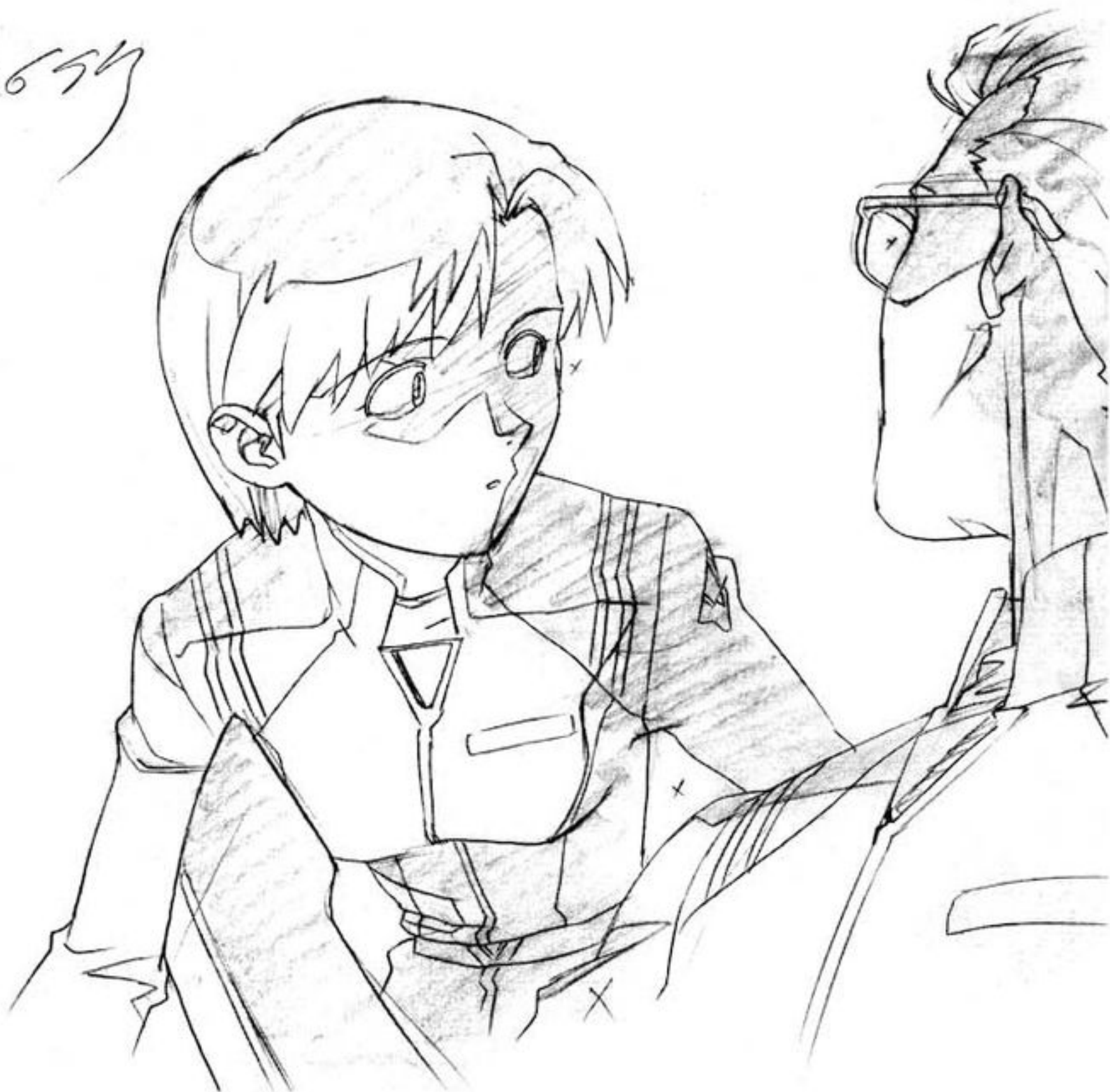

#25-C092



#25-C090





A1  
1/10



1/10  
Acher  
7.11

①

1/10  
A2

1/10



25-100

A 2  
2/1



A 3  
1/1



10:27 1/1 0 2/2

A 5  
B 1 B-2  
9/9

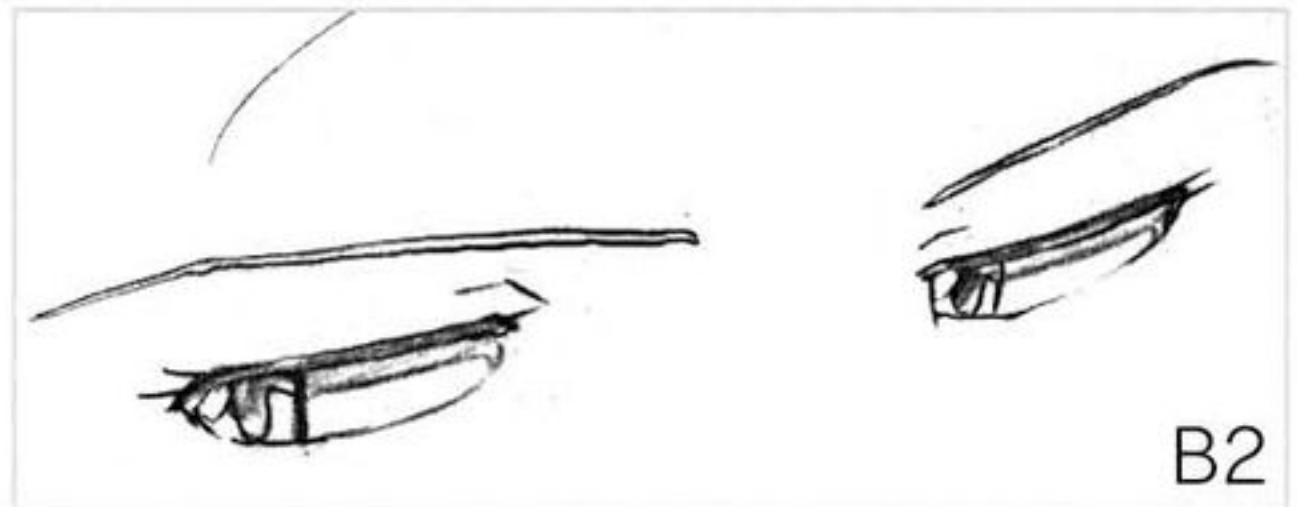

B2







#25-C119

A①

動画様

特効は入りません  
先. 緑色のワシ指しはなし

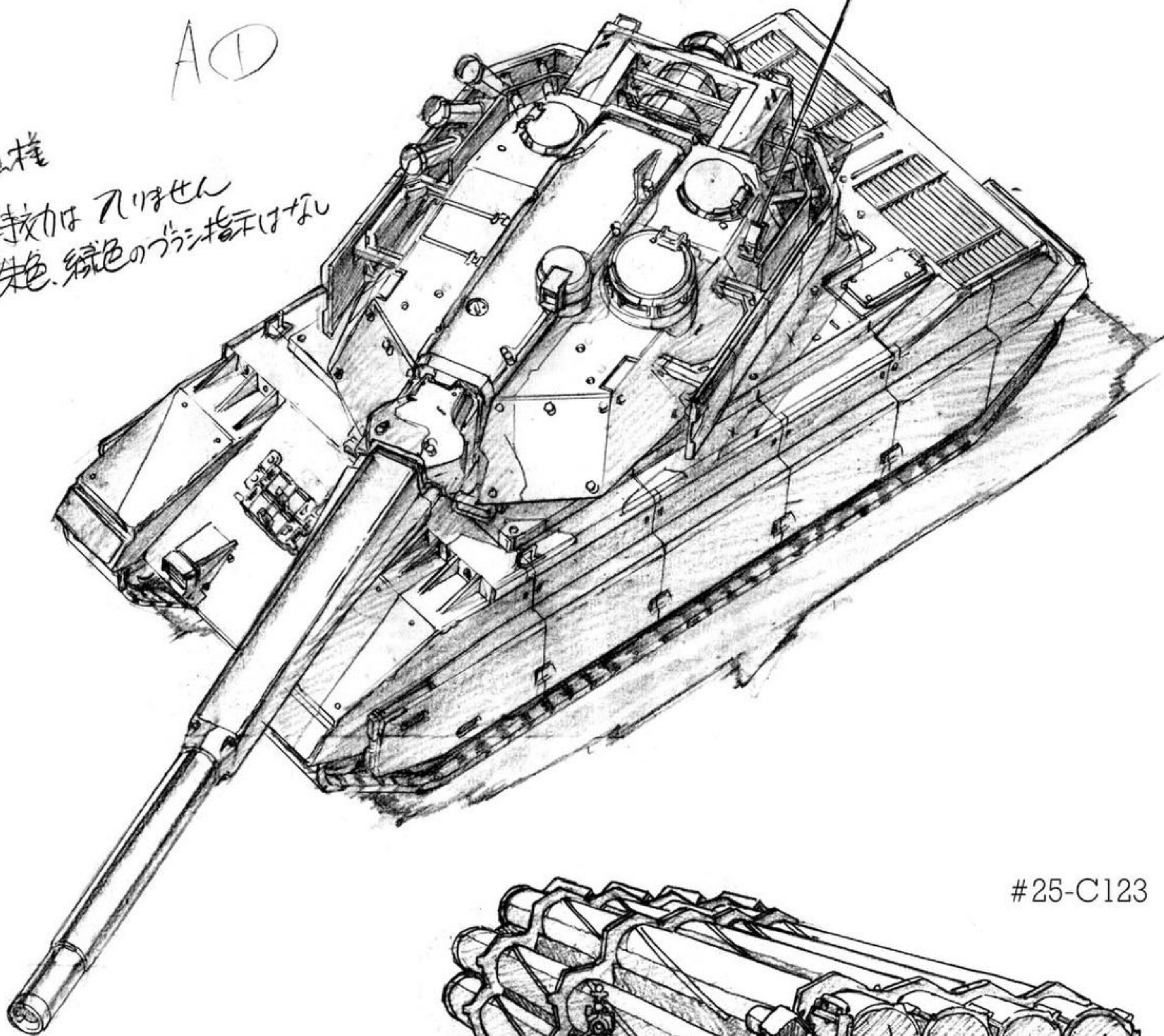

#25-C123

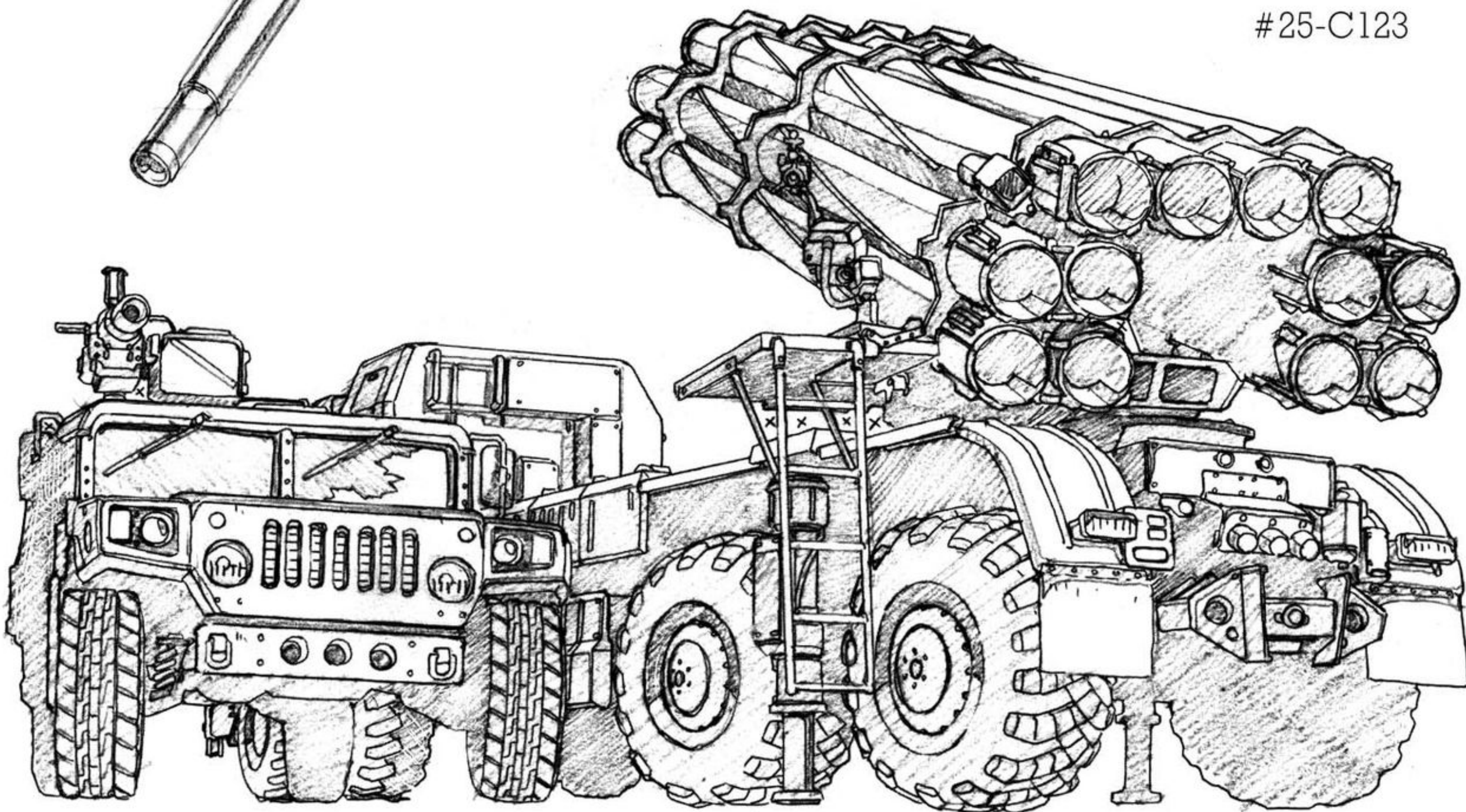





修正原画



修正原画

#25-C146







#25-C147



B-317  
 髪型とポーズの  
 参考 0989





#25-C151,153

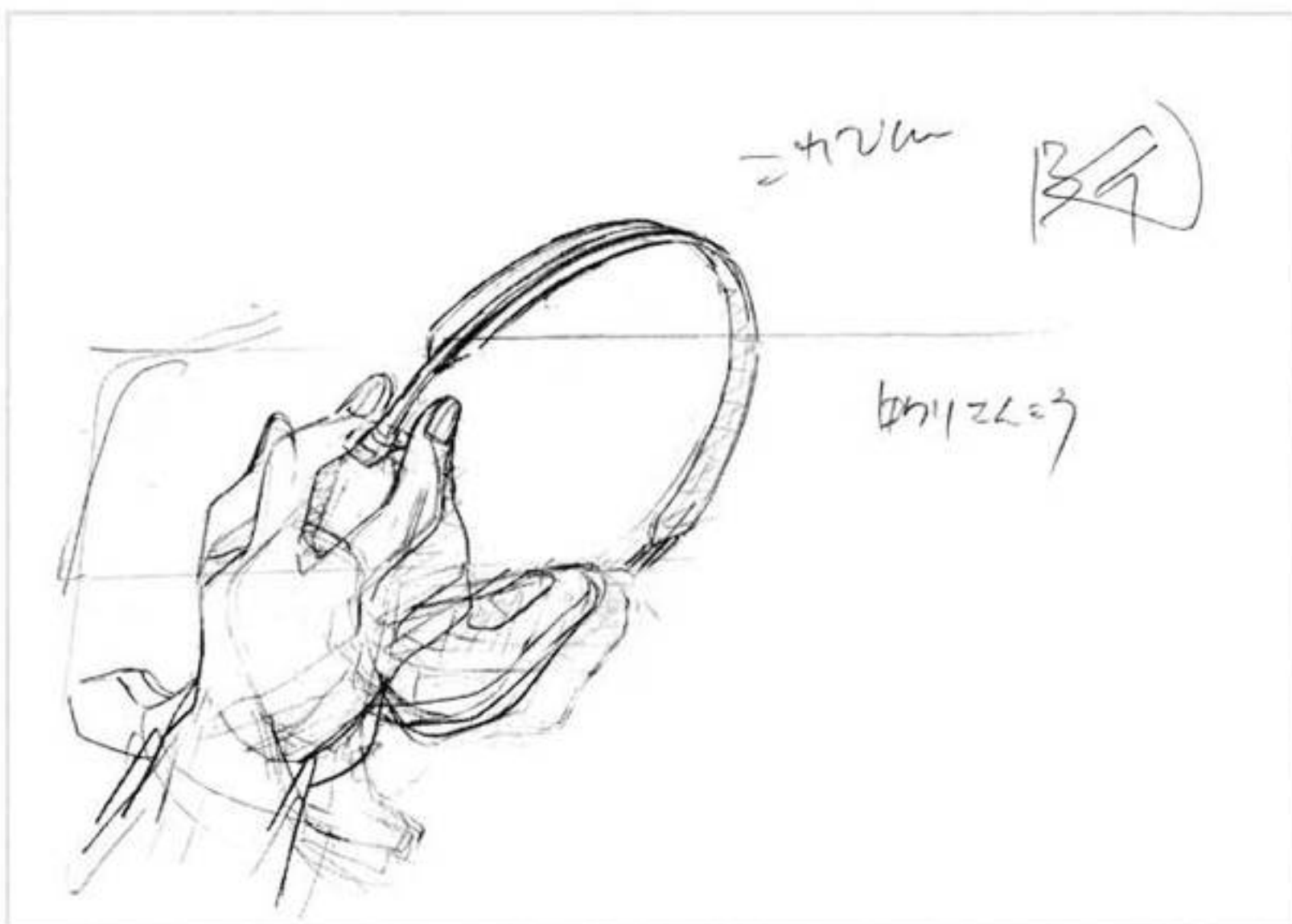



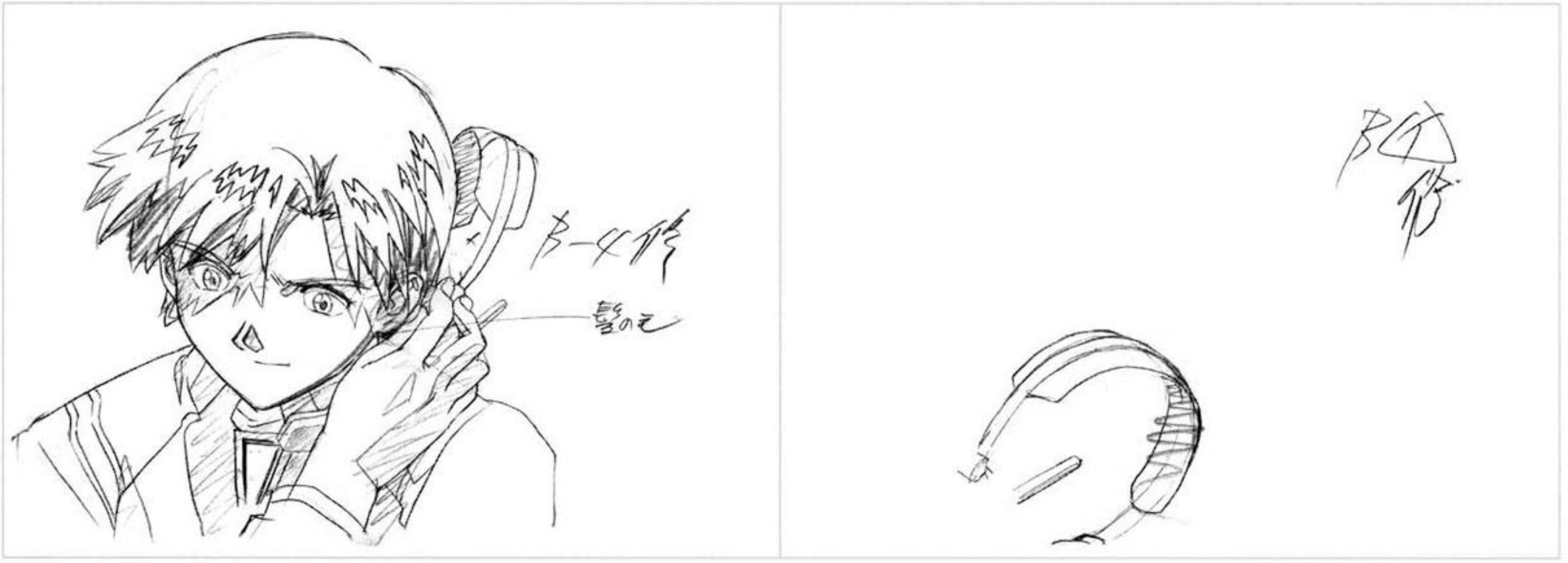





#25-C154





A1修

眼滑B-1

セウゴシズ



#25-C155







A 1/12



A 2/12  
by  
A 23



#25-C186

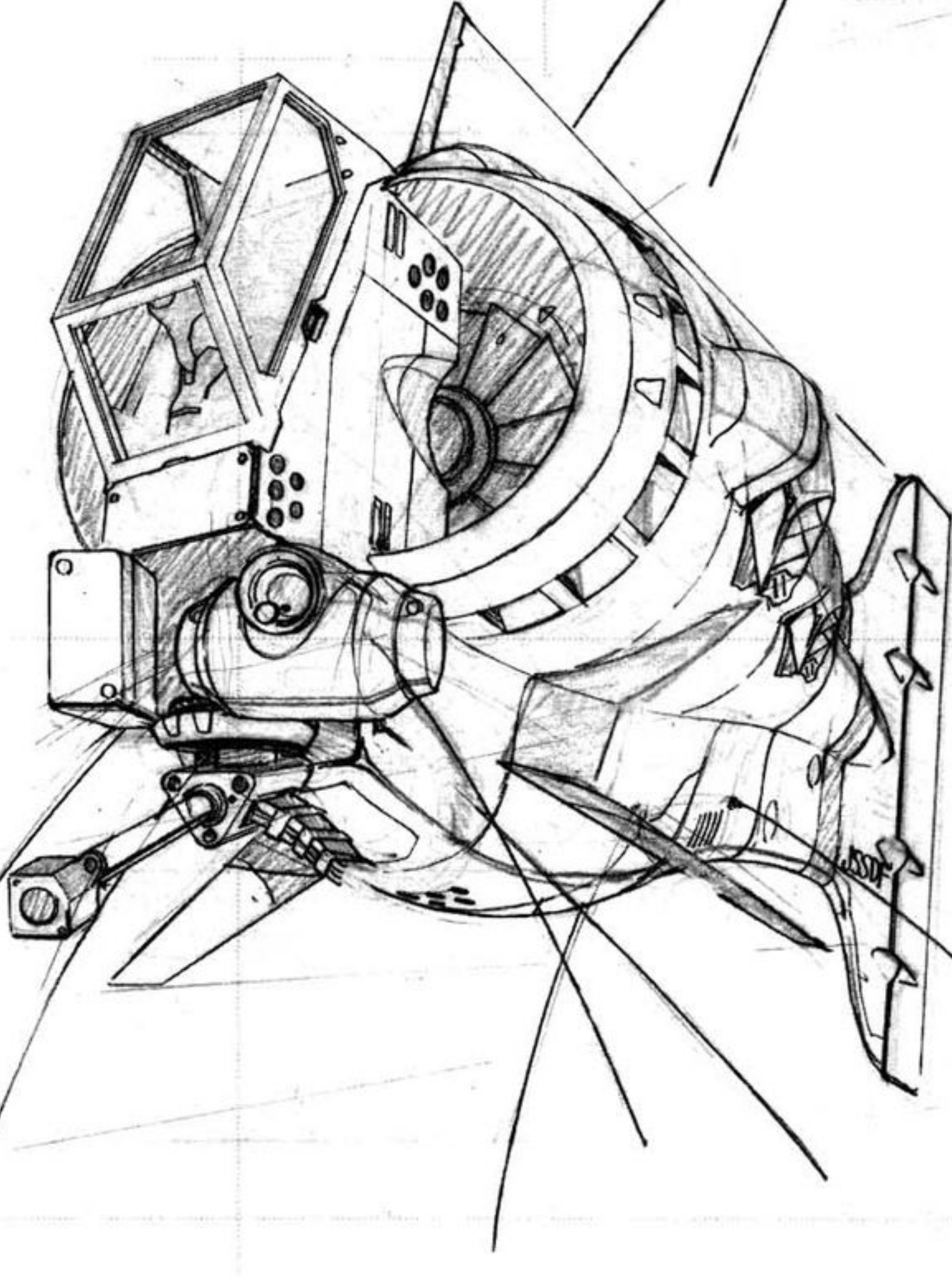
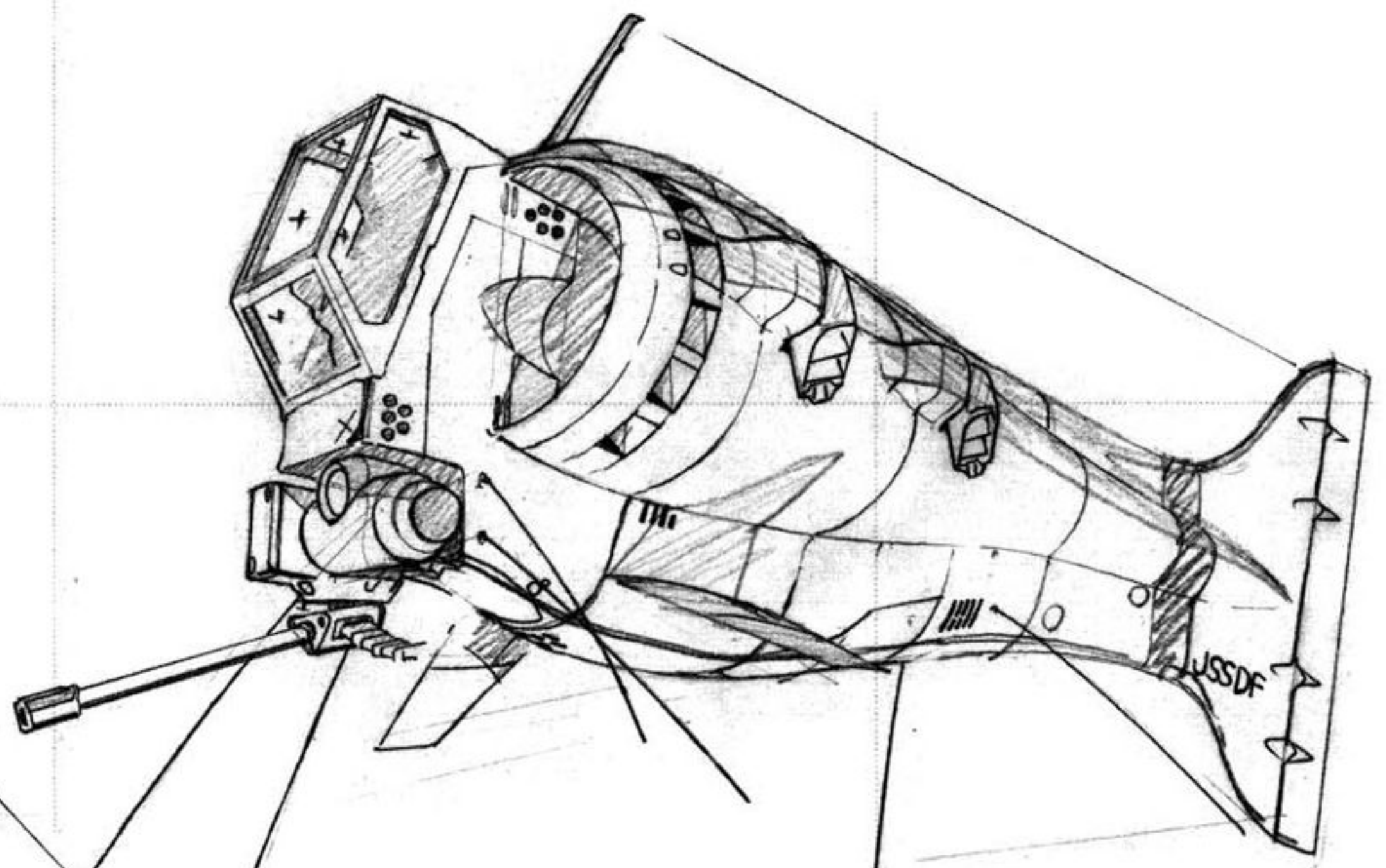

#25-C186

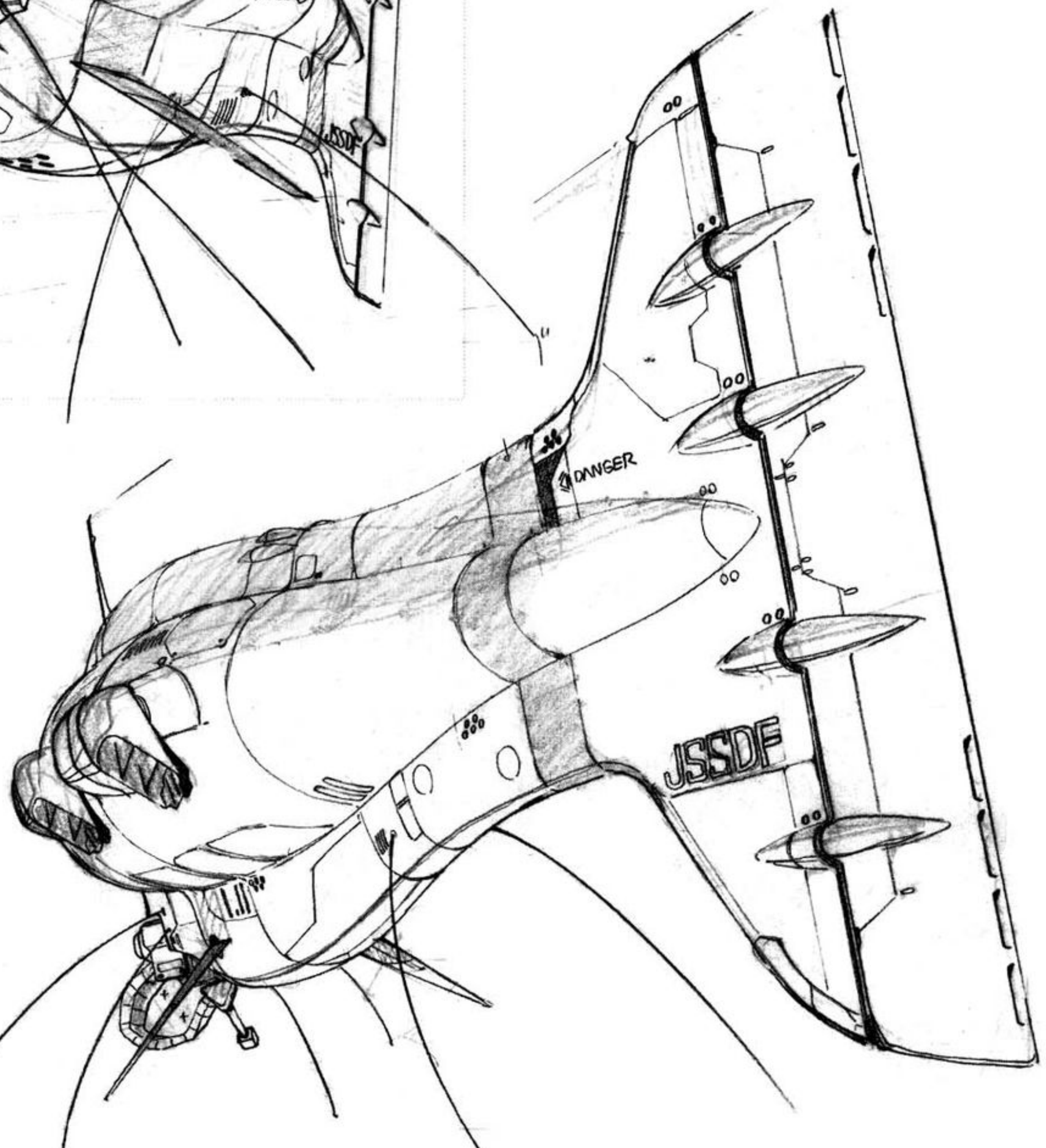

#25-C188





#25-C193

修正原画





#25-C195

B5



(B1)



B6



B2



B7



B3



B8



B4





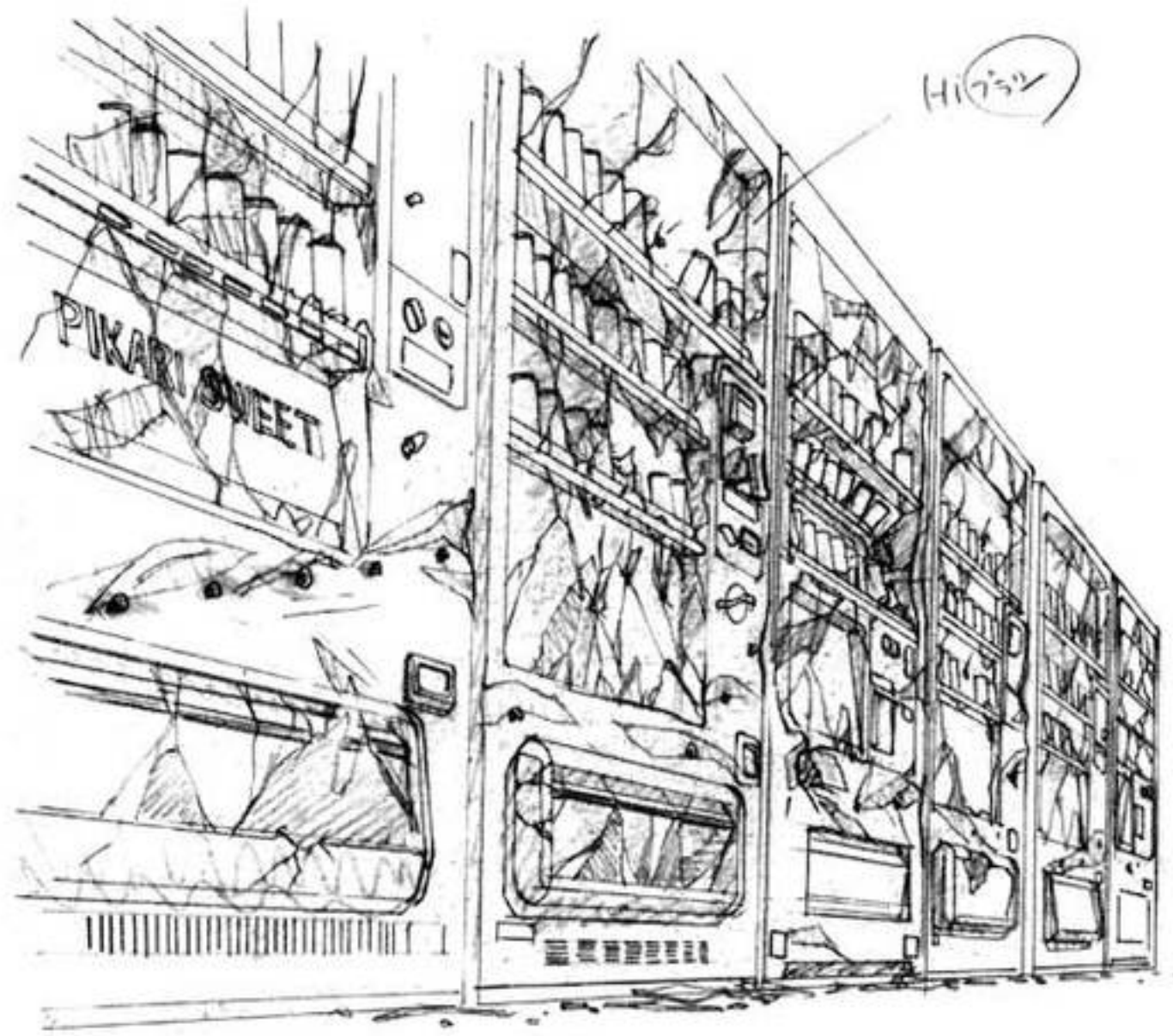

Hi (55)

A (59)

E (12) (12)



#25-C195



D39



P1

修正原画



D4



D2



D5



D3



D5



修正原画



修正原画



D6



D6



修正原画



修正原画







D-10  
113

修正原画



(8)



(D11)



(D9)



D11  
113

修正原画



D9  
113

修正原画



D12

D11113



D10





修正原画



修正原画



D13

D-13 11/3



修正原画





E3



F1

修正原画



E3



E2



E4



F2

修正原画



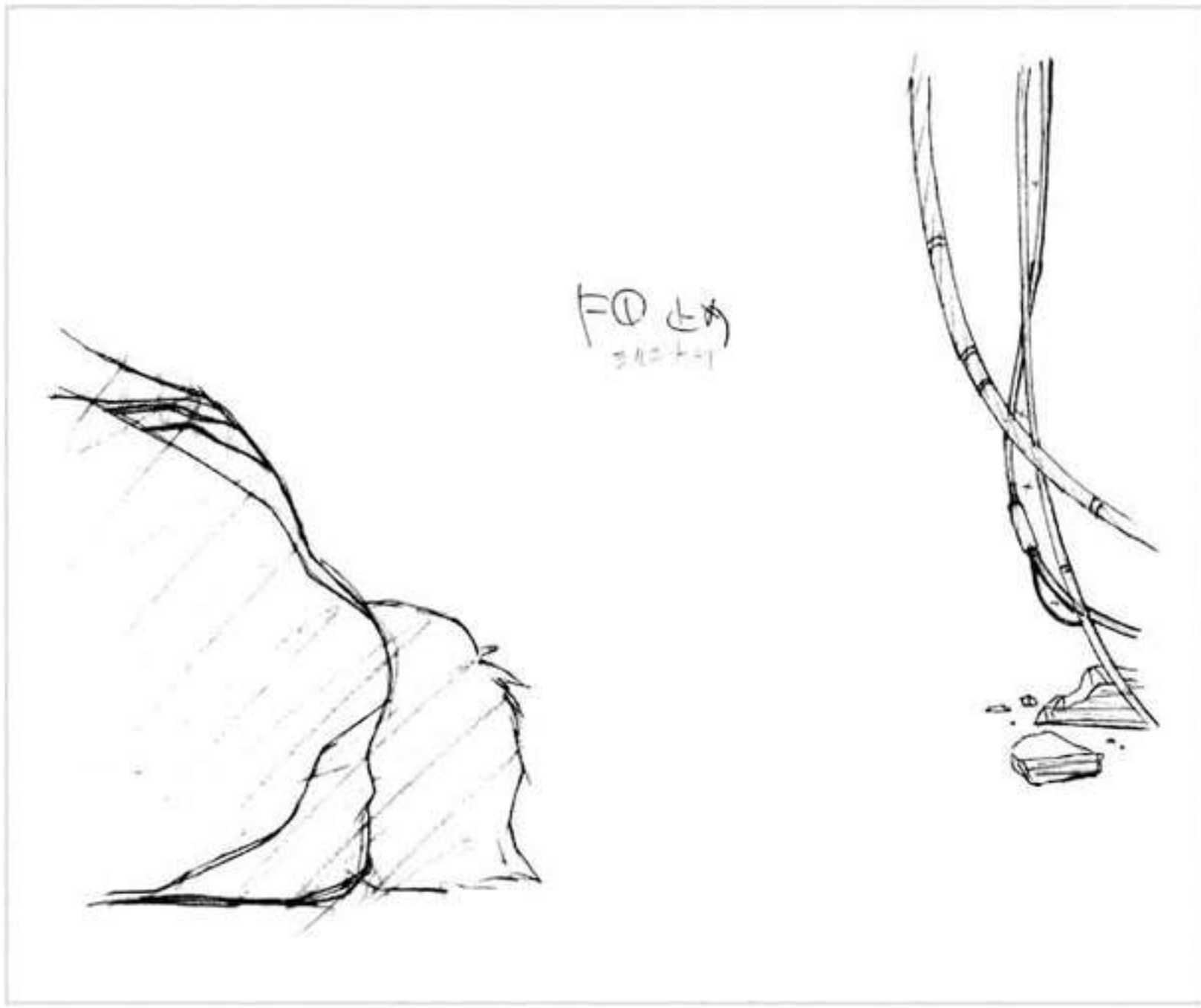

F0 6x  
3x2+1



E4y

#25-C195

タイムシート

A	B	C	D/E	
①	X	X	①	1
				2
				4
				6
②		②		8
③				10
X				12
				14
				16
①				18
				20
②				22
3				24
X				26
				28
				30
				32
				34
				36
				38
①				40
				42
②				44
3				46
X				48
				50
				52
④				54
				56
⑤				58
				60
				62
⑥				64
				66
				68
				70
⑦				72

修正原画



E5

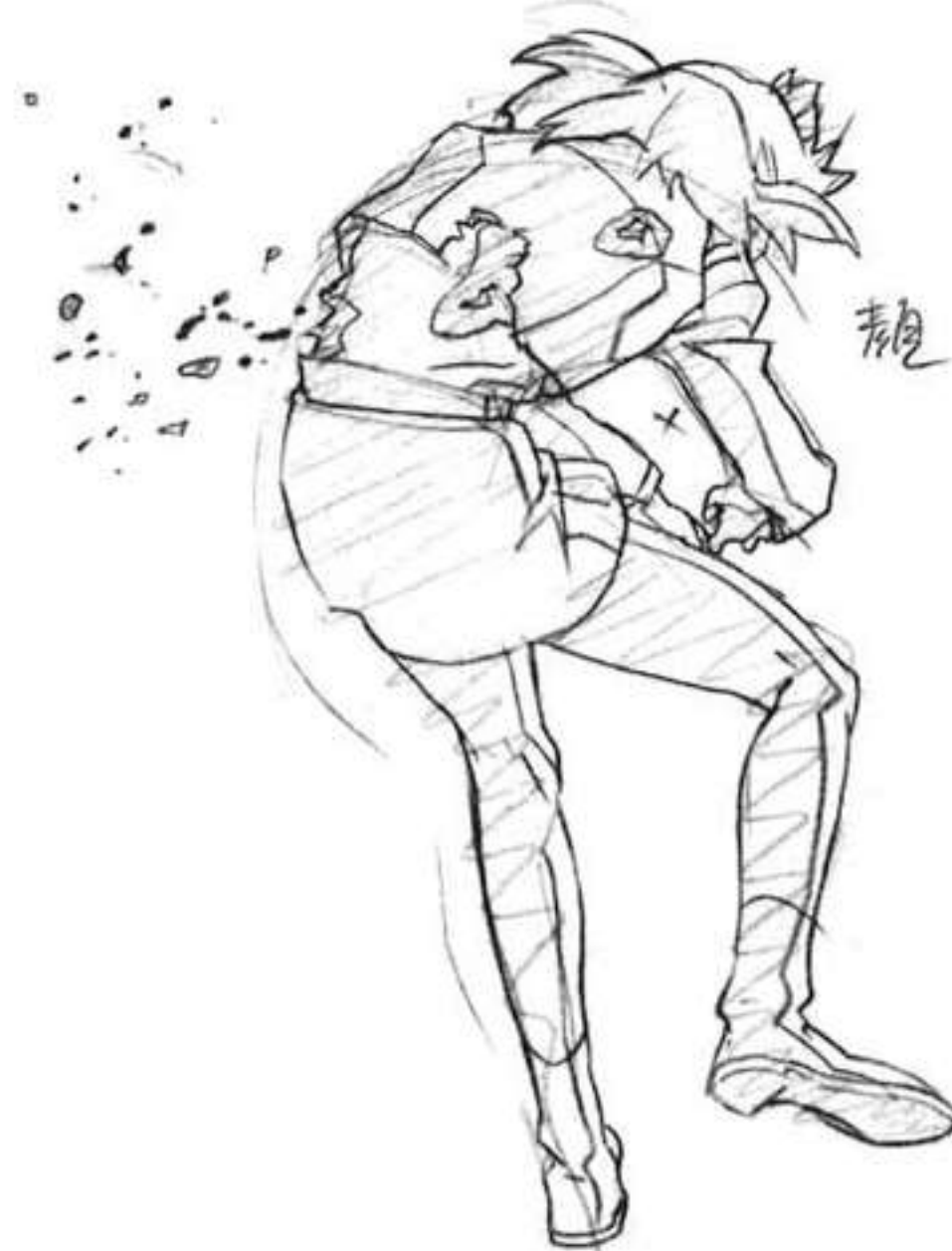

E5y

修正原画





Art  
1/17

#25-C204

Art  
1/17  
RD  
2  
3



Art



A7

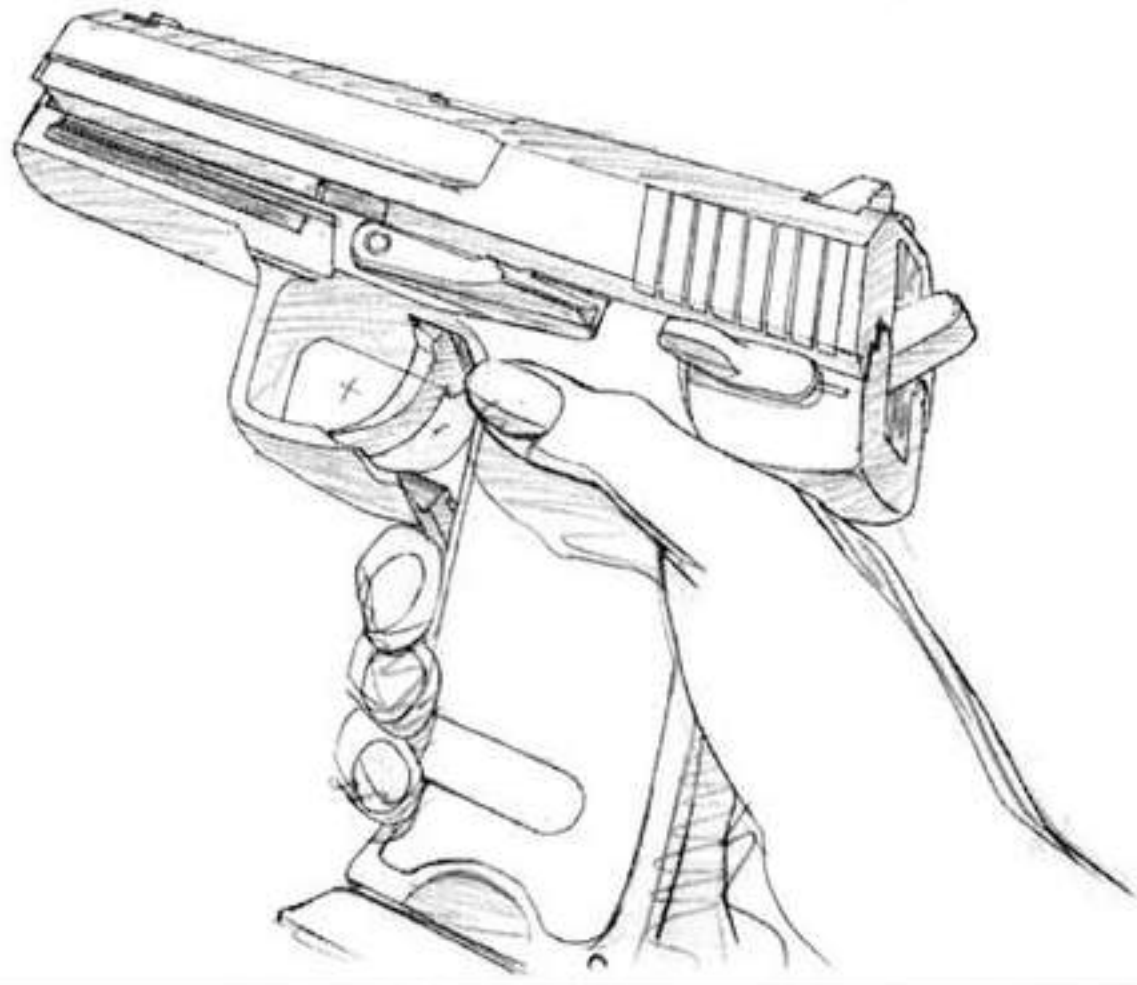

A113

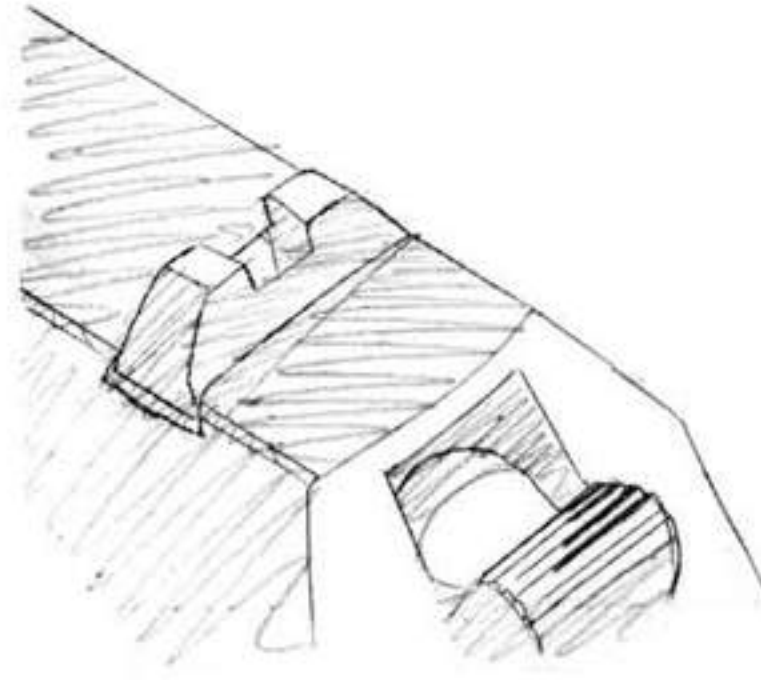

#25-C213,215

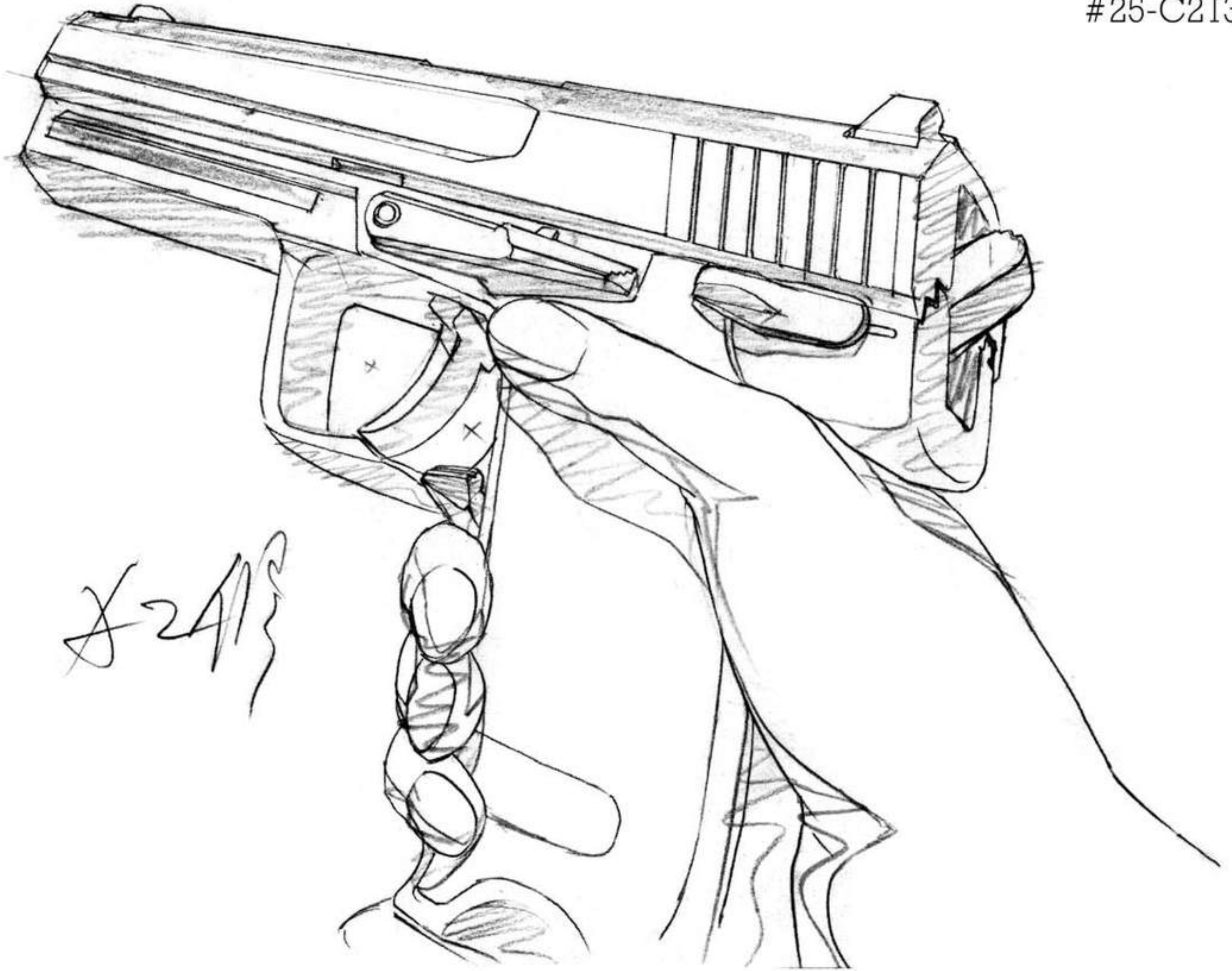

X-2A13

A7 113

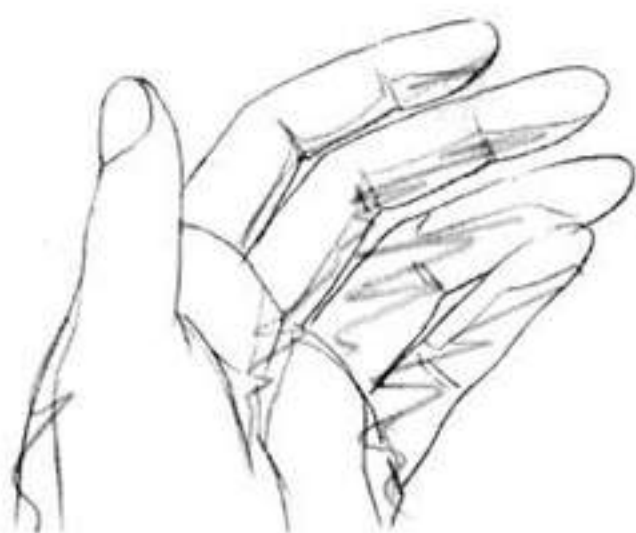

A3 113





A6  
1/3

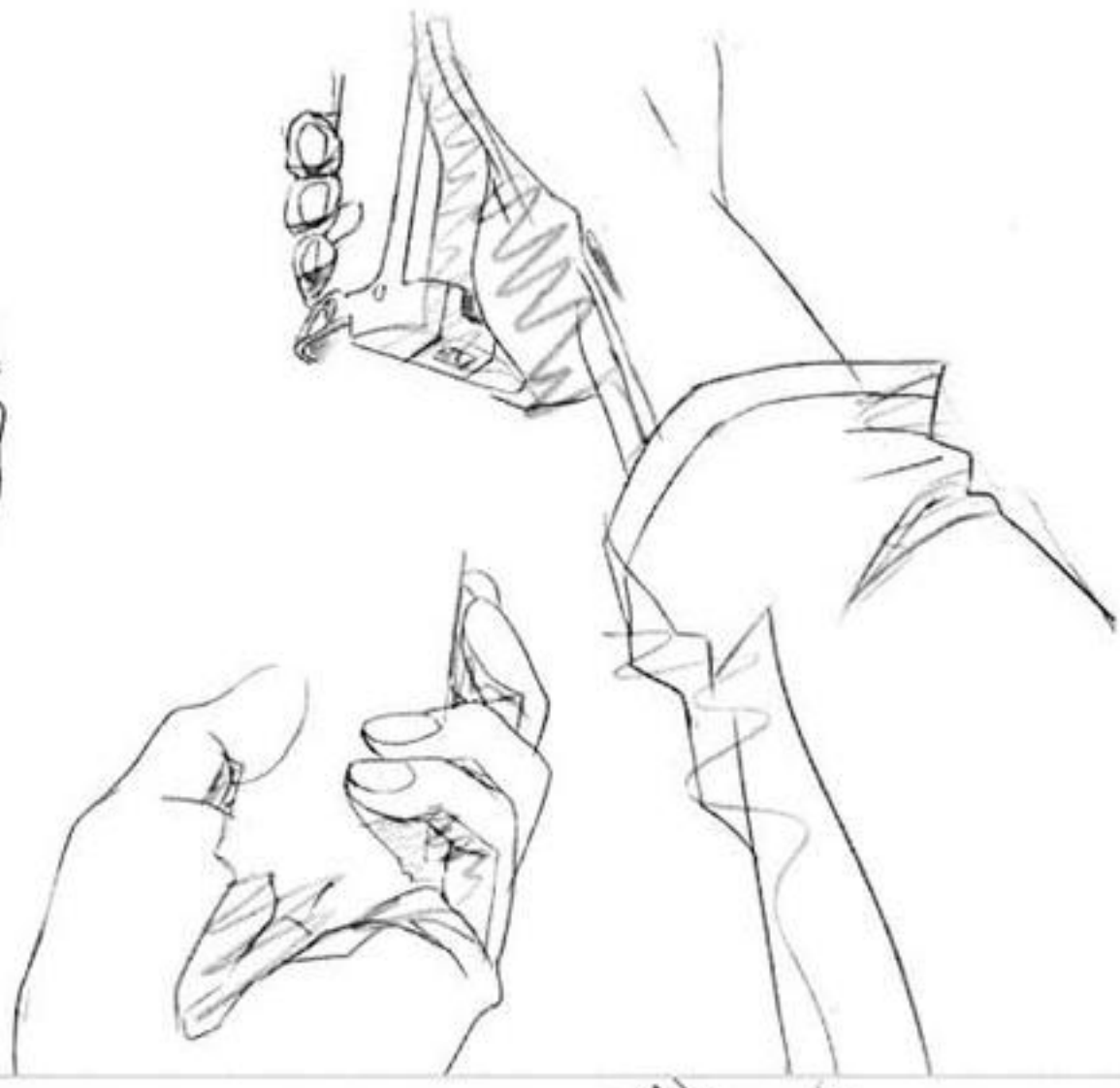

A4  
1/3



A7  
1/1



A5

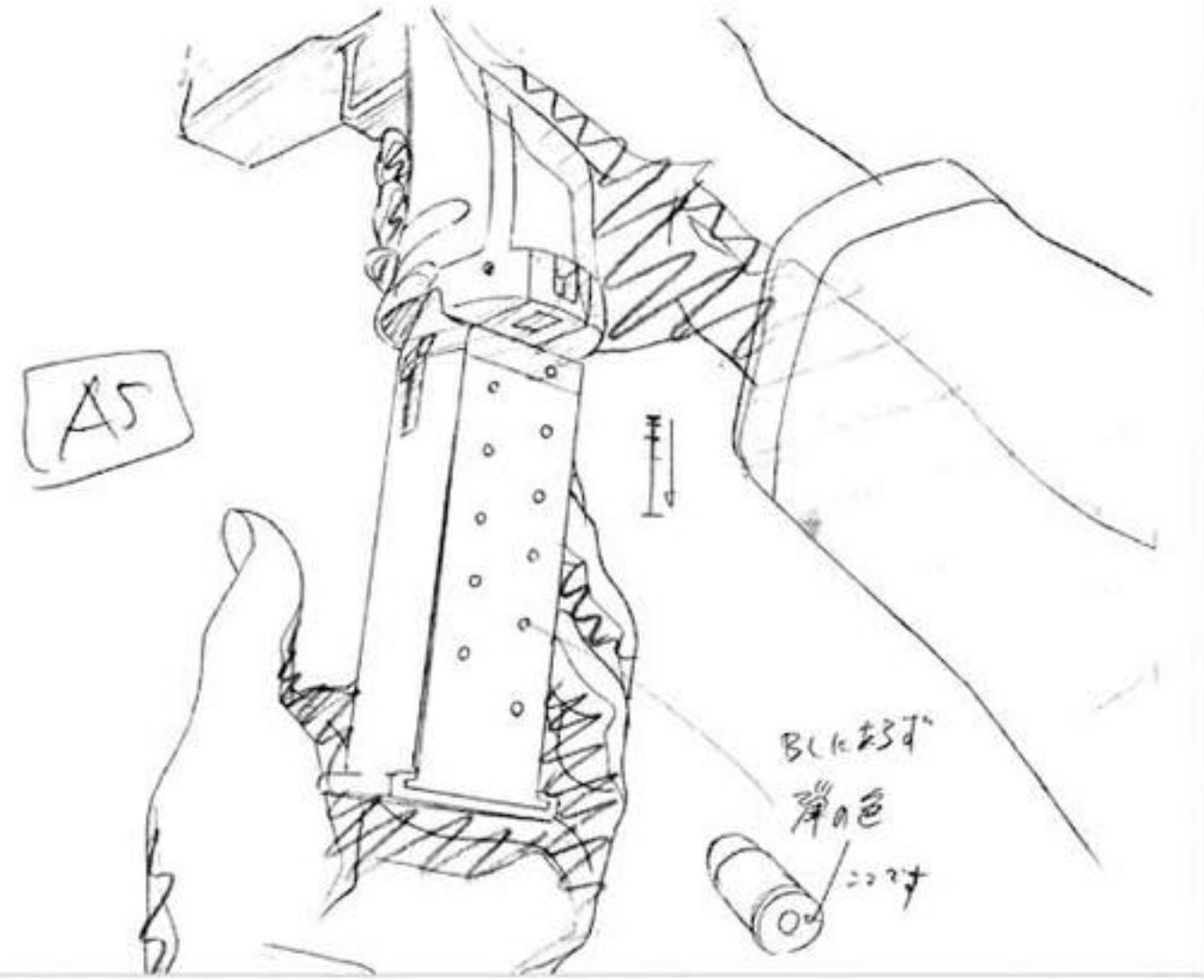

Black  
00  
2027

A7  
1/3



A5  
1/3

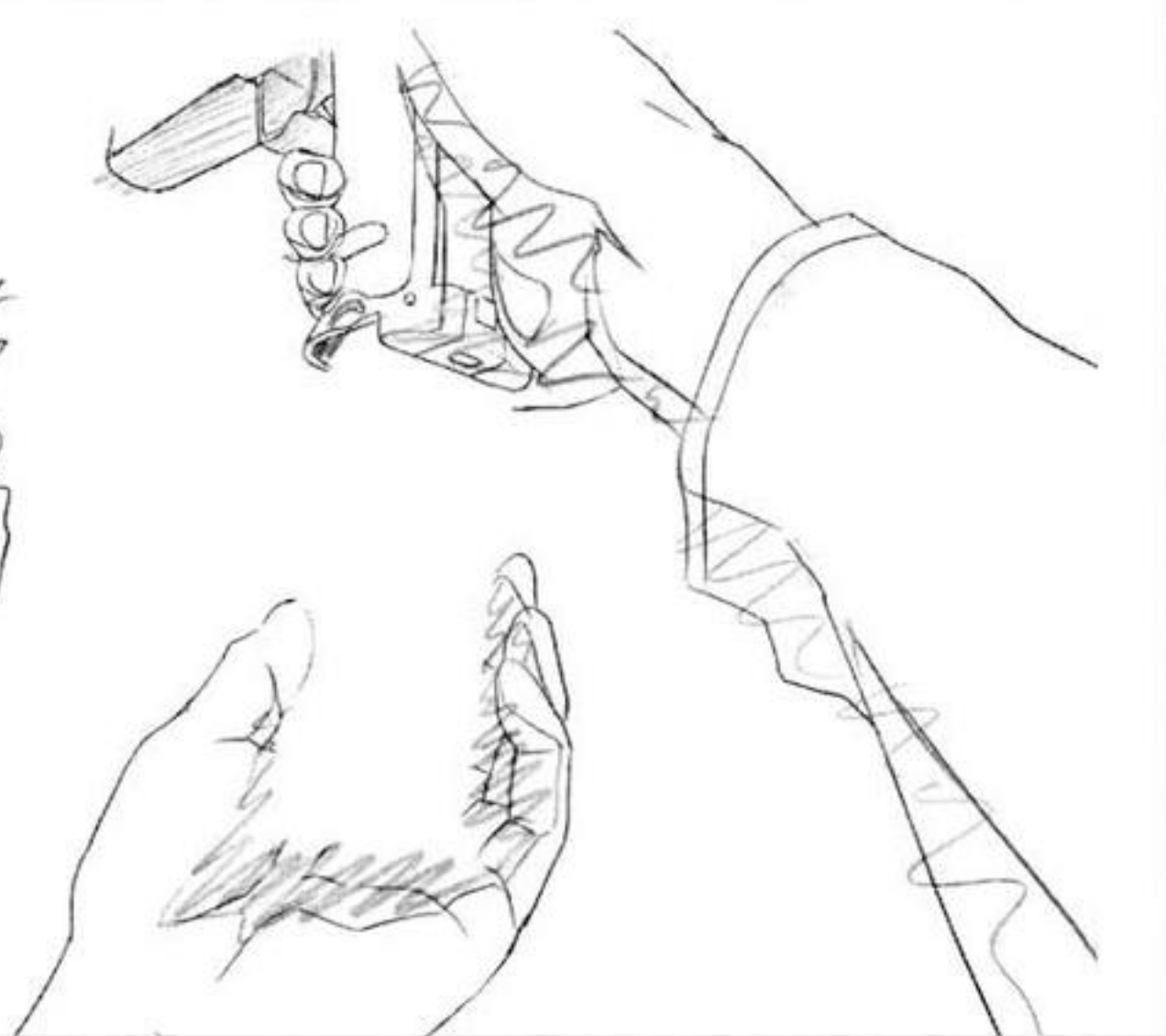

A8  
1/3



A6









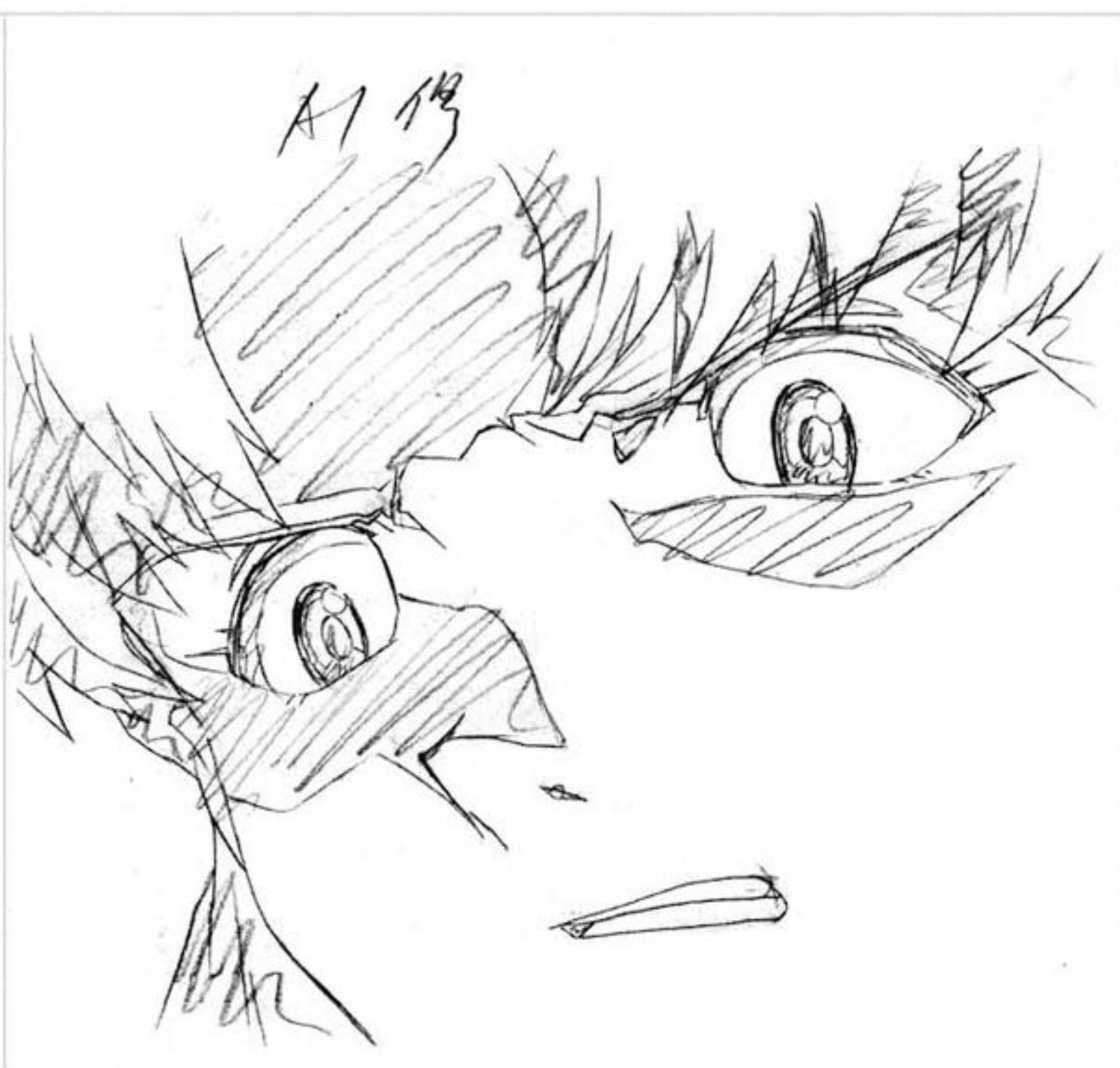

#25-C214

修正原画



A2



他 A2

A1

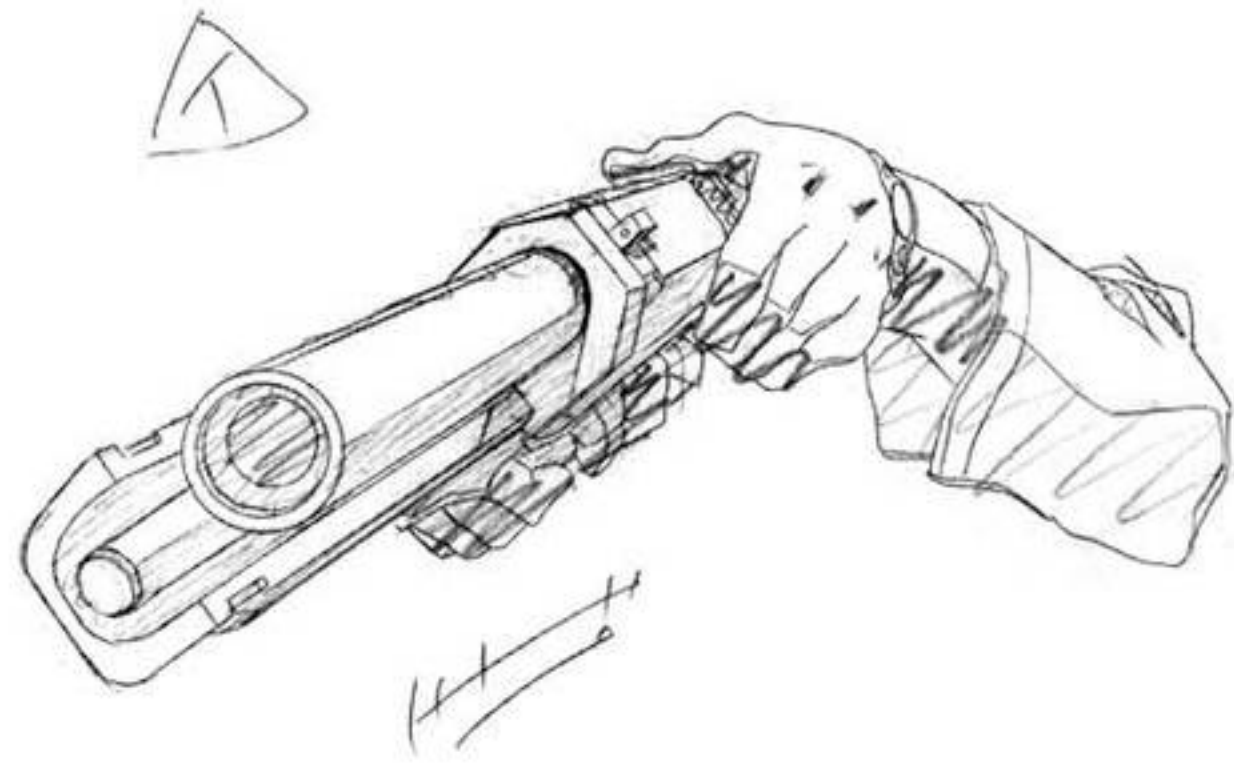

A1

缸  
不要



修正原画

A2

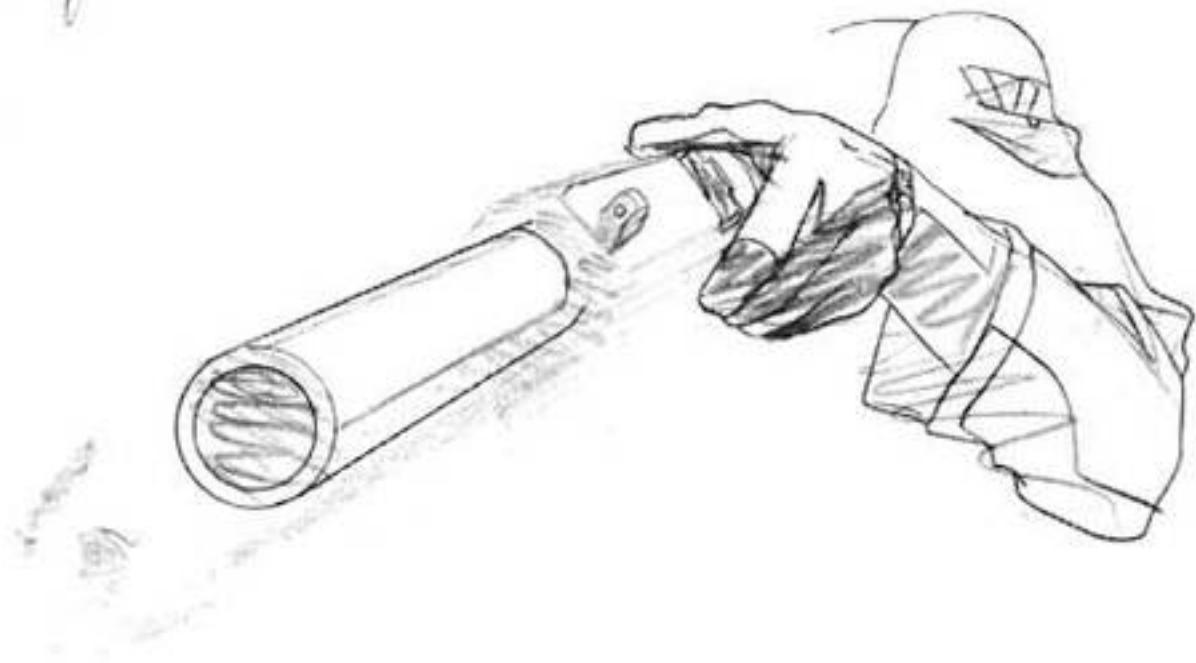

A2

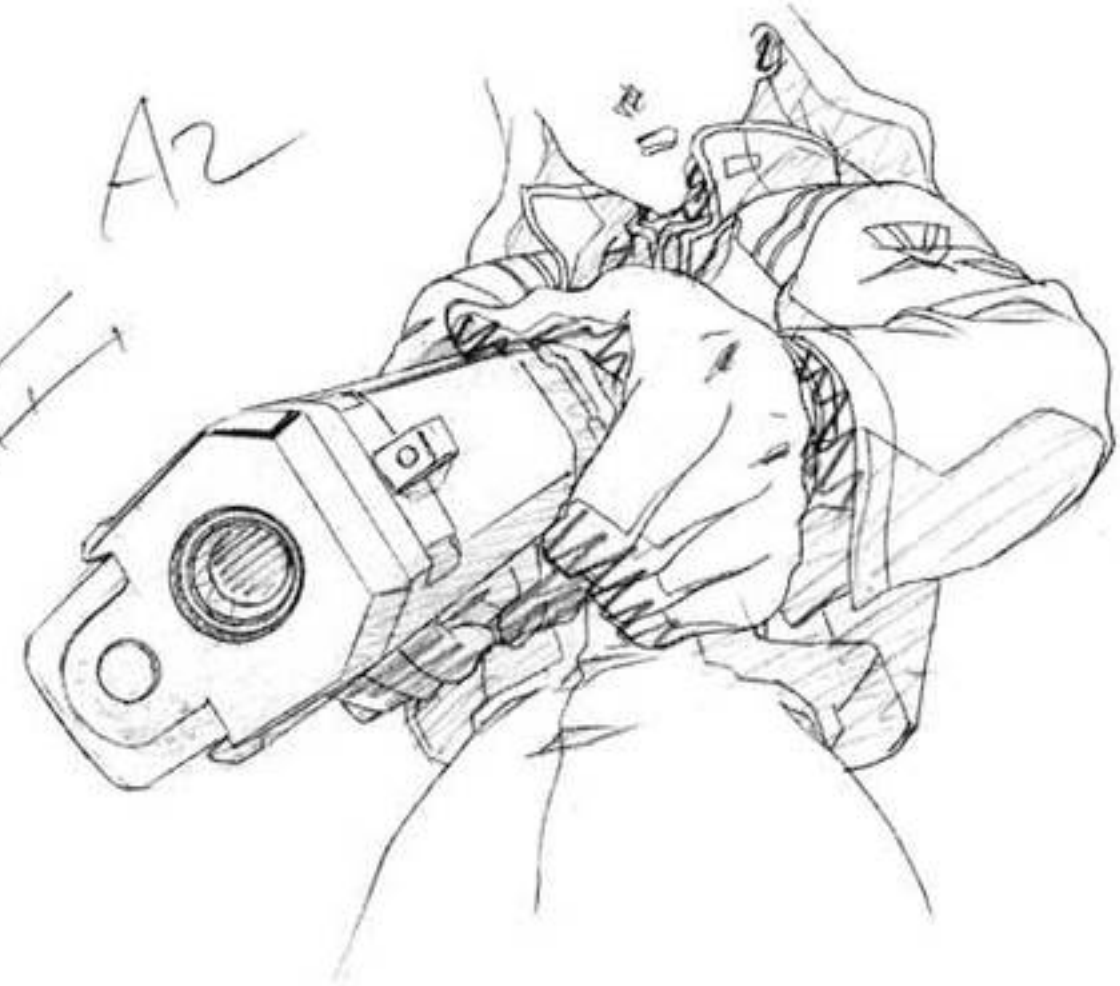

修正原画

A3



A2/B



修正原画



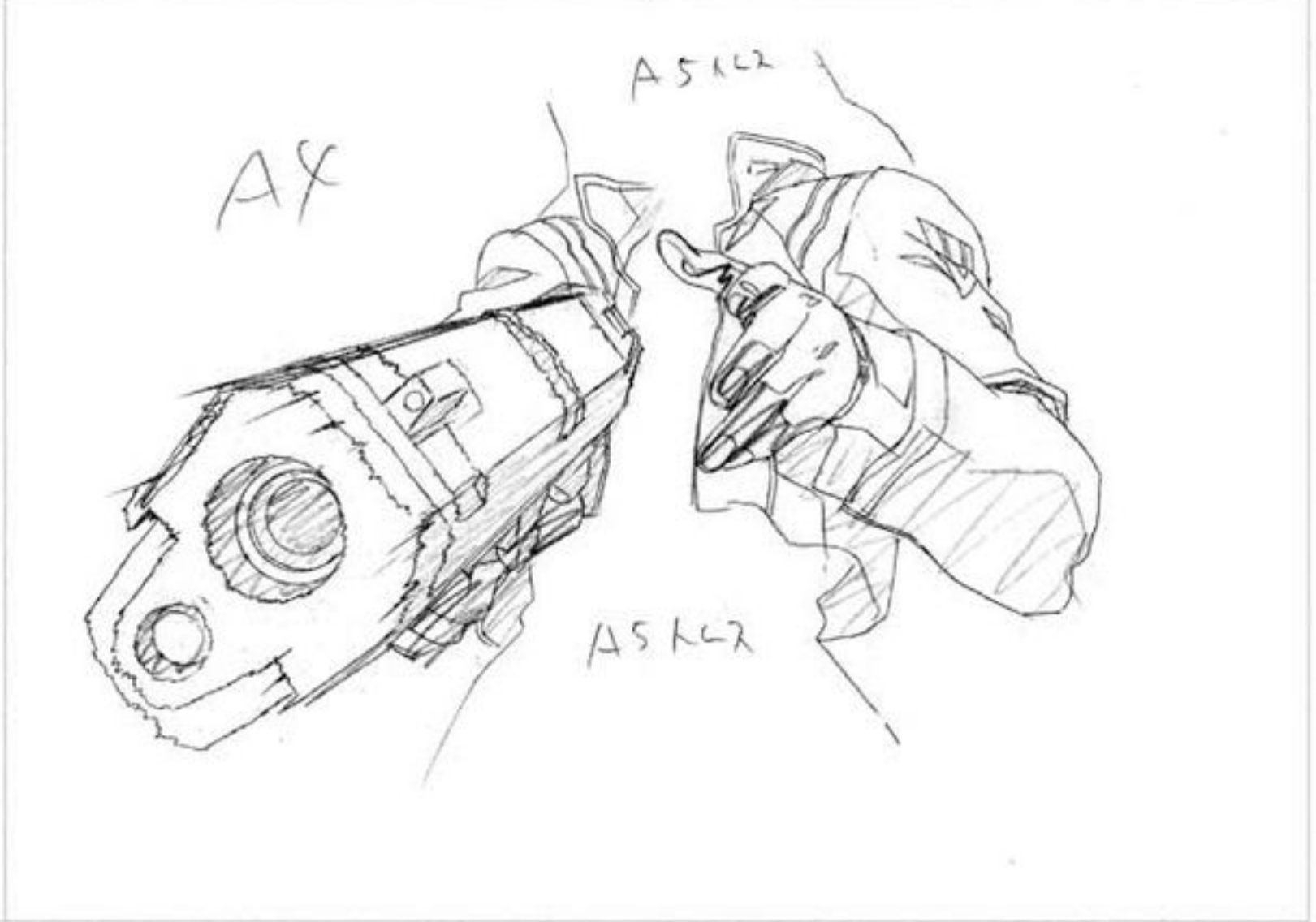
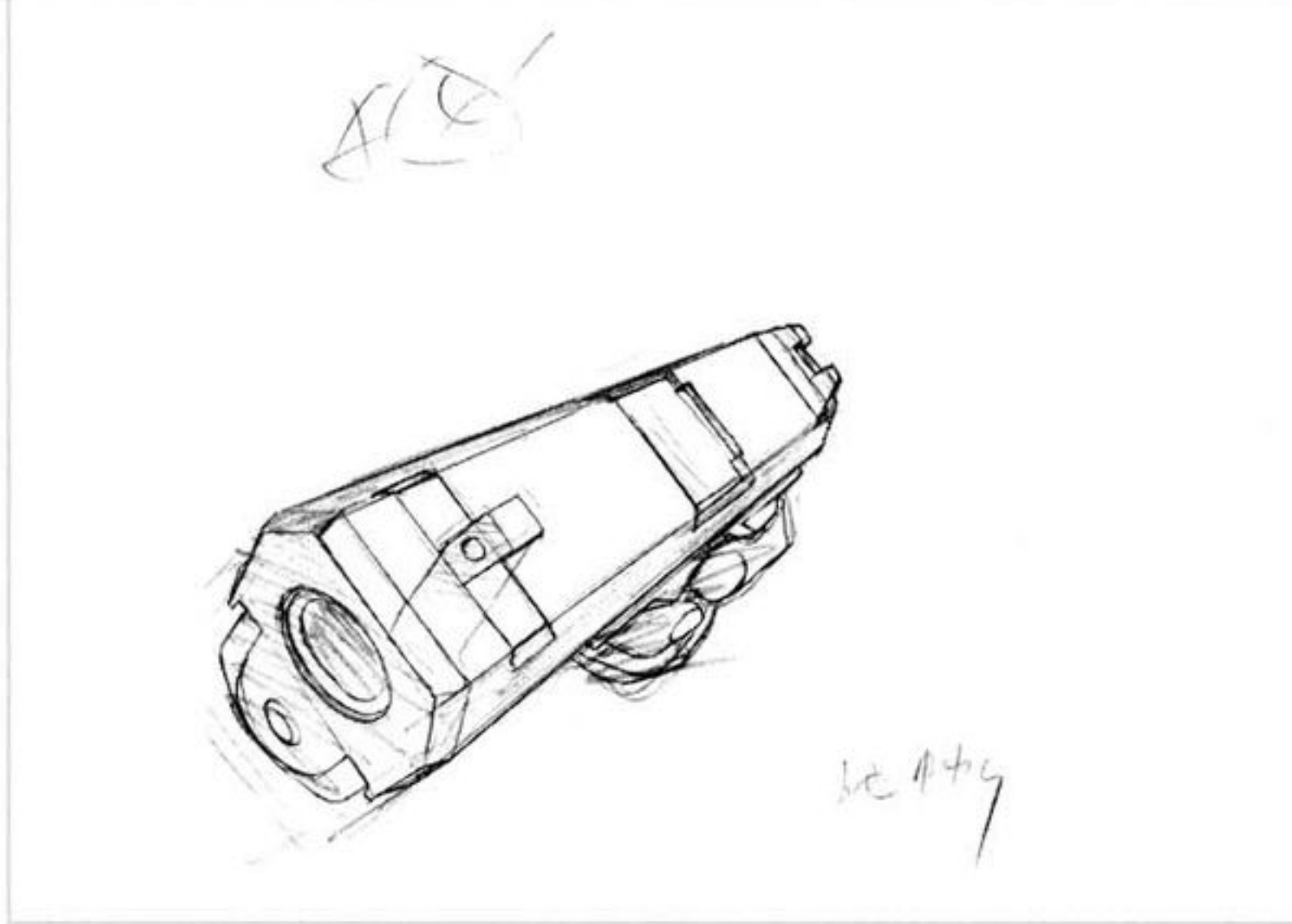
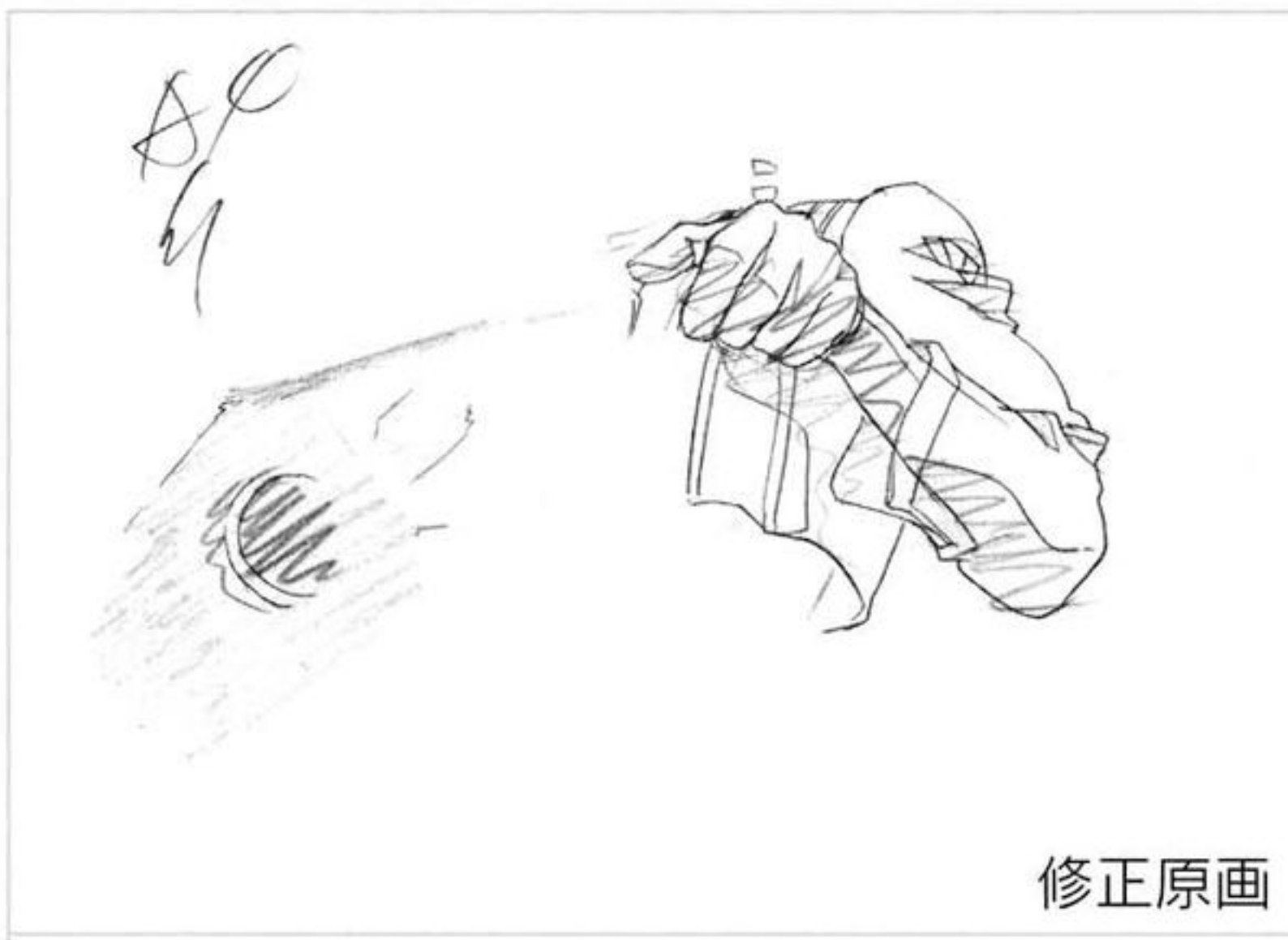

#25-C216

A	B		
1		2	
2		4	
3		6	
4		8	
5		10	
6		12	
7		14	
8		16	
9		18	
10		20	
11		22	
12		24	
13		26	
14		28	
15		30	
16		32	
17			
18			

タイムシート

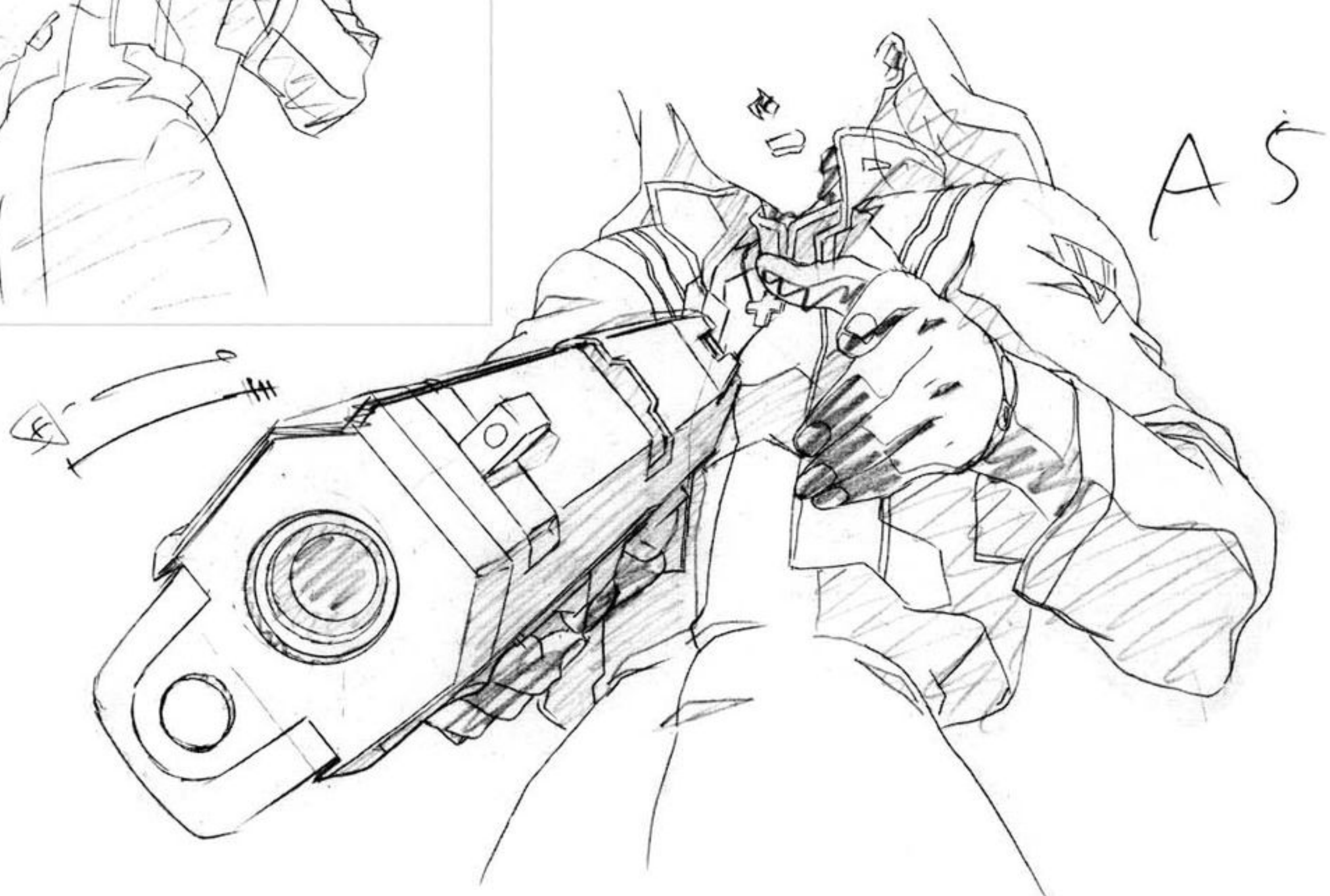









#25-C233,248





(A) 鏡の中の♀ (B)



#25-C260

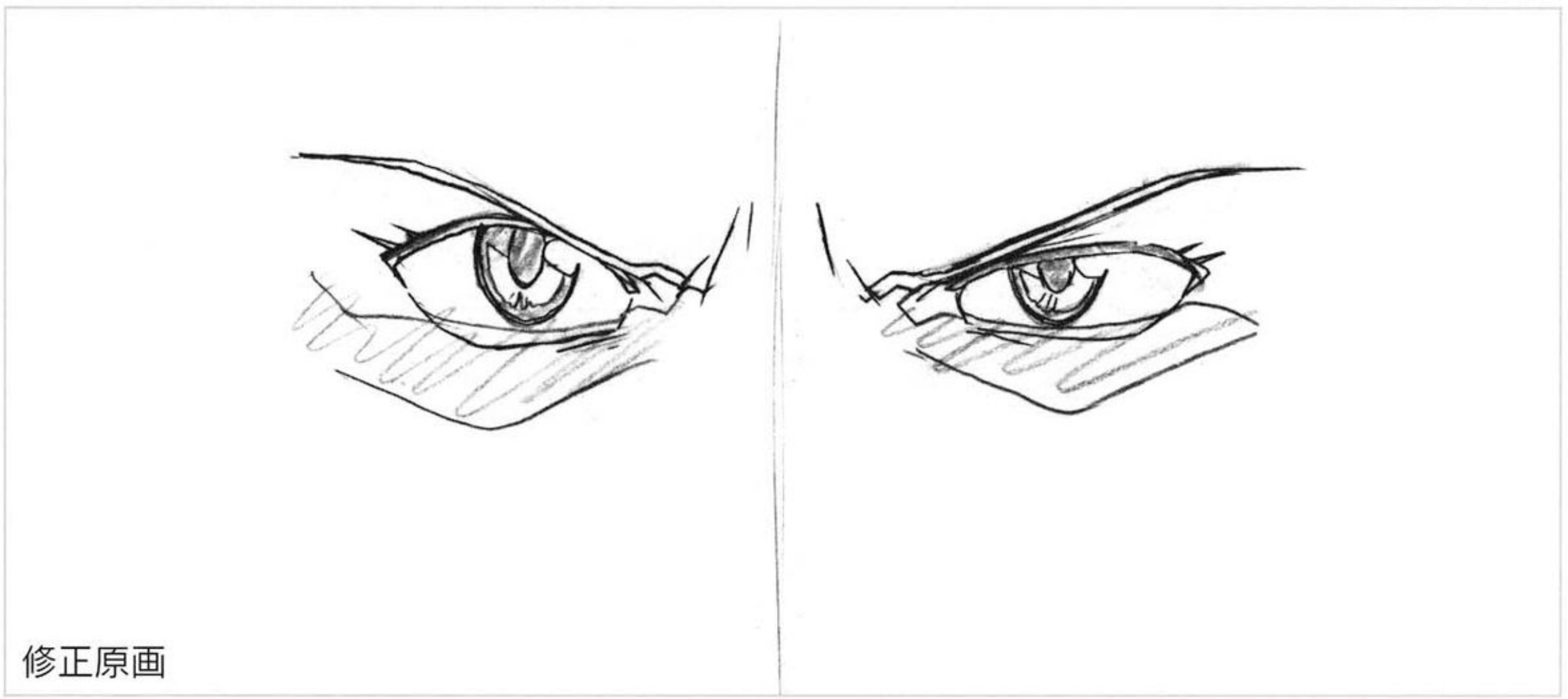

修正原画





B2



B1  
H27要



B4



B7

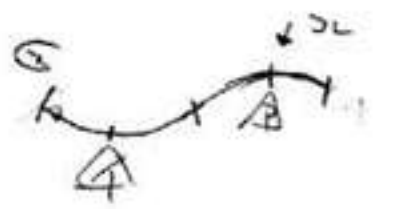

B5



B6



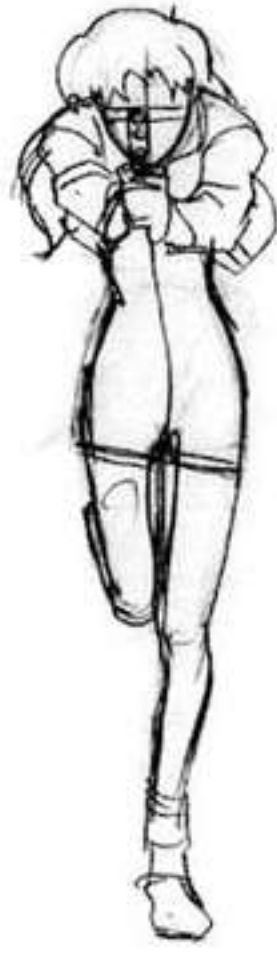

B/A



B3



B5



B4



B6



髪のリズム  
③

B7



39R



β10



β7



A

↑  
T'k'c (7)



↑  
T'k'c (7)

A



β11



β8



B-13  
作



修正原画



12



B/K



B-14  
作

修正原画



B13



R-15  
1/3



修正原画

선  
d-10



A



3/6

그림  
기분  
1/5  
1/3



A

修正原画

R-11  
1/3



修正原画



3/5





B17



A	B	C			
①	△		1	⑩	2
△	②		2	⑪	4
△	③		4	⑫	6
△	④	X	6	⑬	8
△	⑤		8	⑭	10
△	⑥		10	⑮	12
△	⑦		12	⑯	14
①	⑧		14	⑰	16
△	⑨	X	16	⑱	18
△	⑩		18	△	20
△	⑪		20	△	22
△	⑫		22	△	24
△	⑬		24	△	
△	⑭			△	
△	⑮			△	
△	⑯			△	
△	⑰			△	
△	⑱			△	
△	⑲			△	
△	⑳			△	
△	㉑			△	
△	㉒			△	
△	㉓			△	
△	㉔			△	
△	㉕			△	
△	㉖			△	
△	㉗			△	
△	㉘			△	
△	㉙			△	
△	㉚			△	
△	㉛			△	
△	㉜			△	
△	㉝			△	
△	㉞			△	
△	㉟			△	
△	㊱			△	
△	㊲			△	
△	㊳			△	
△	㊴			△	
△	㊵			△	
△	㊶			△	
△	㊷			△	
△	㊸			△	
△	㊹			△	
△	㊺			△	
△	㊻			△	
△	㊼			△	
△	㊽			△	
△	㊾			△	
△	㊿			△	

タイムシート





A4

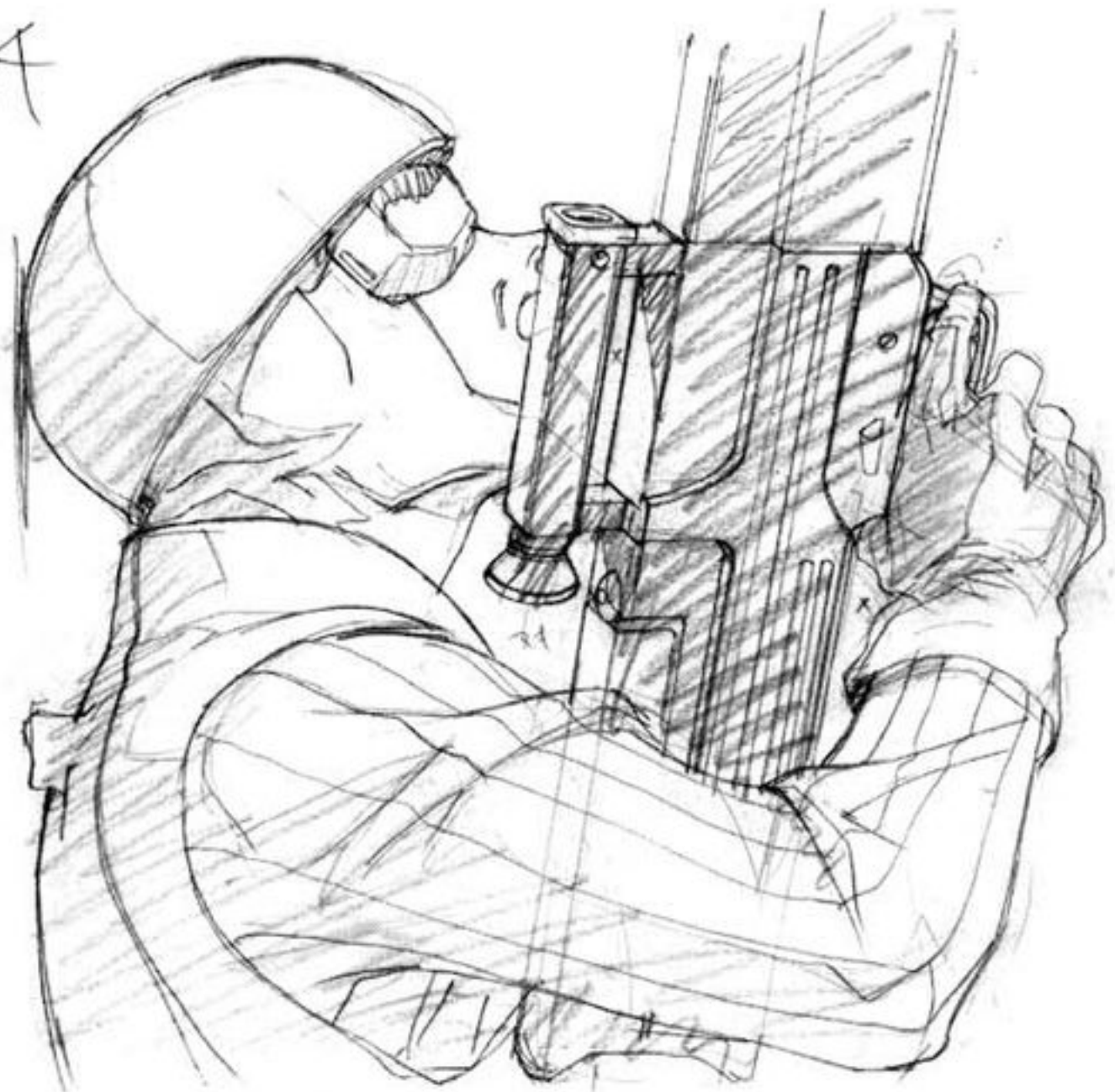

01



A5



A2



A6



A3

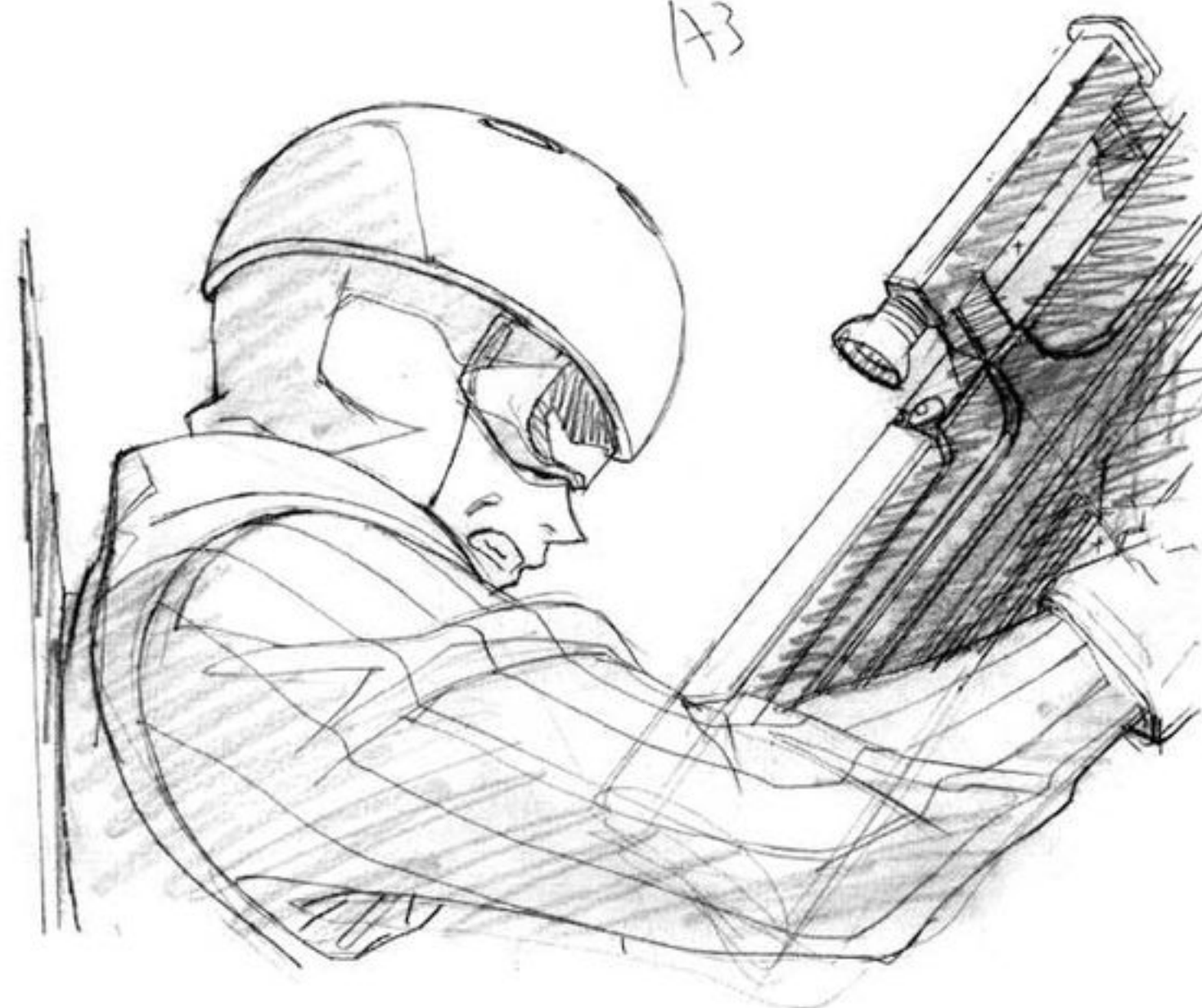



修正原画

A9 13



(A10)



(A8)



修正原画

A10 13



A9





修正原画



他部

A11



修正原画



修正原画

A11 77

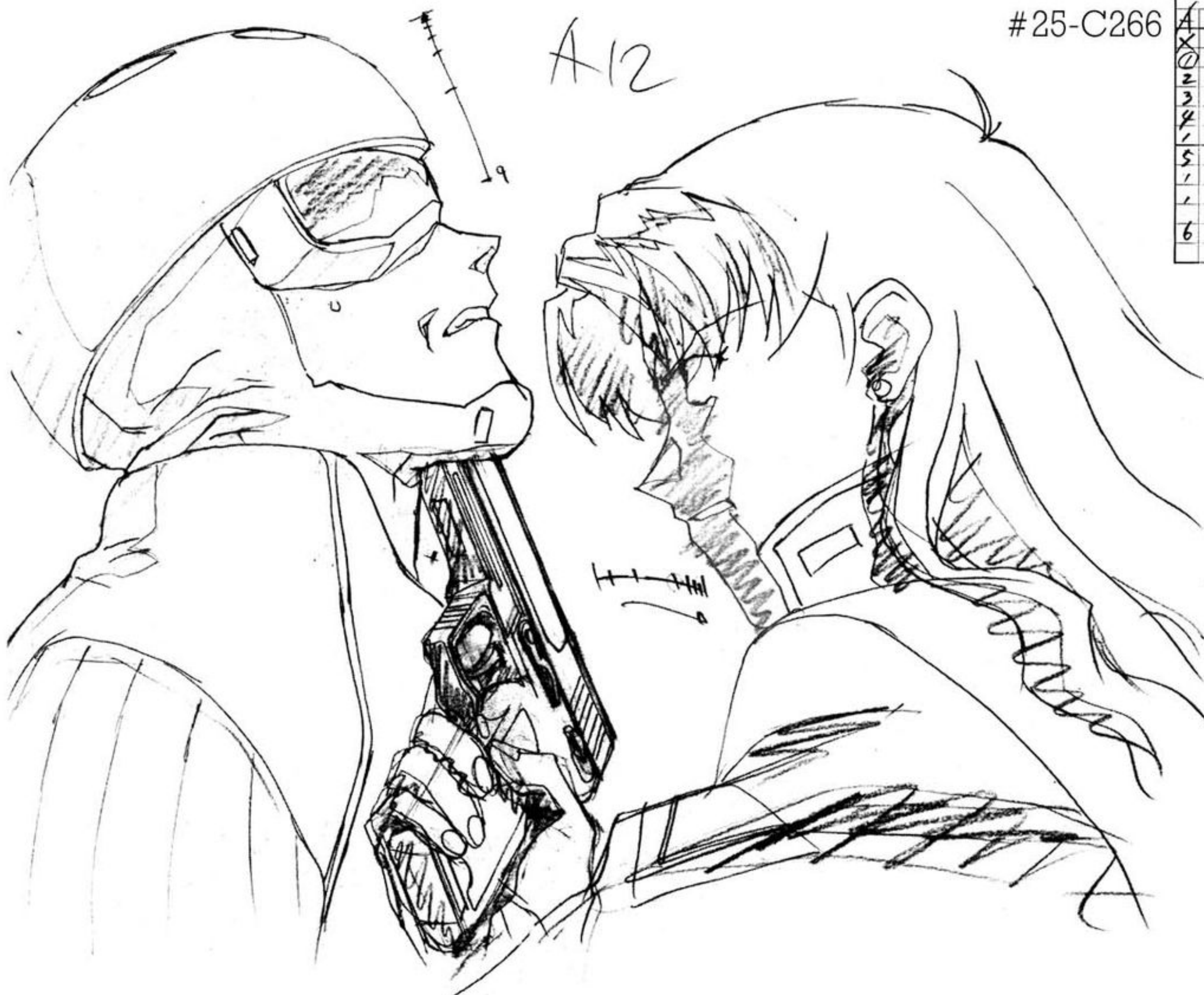

A12

#25-C266

A		
X		
1		2
2		
3		4
4		
5		6
6		
7		8
8		
9		10
10		
11		12

1		14
2		16
3		18
4		20
5		22
6		24
7		26
8		28
9		30
10		32
11		34
12		36
13		38
14		40
15		42
16		44
17		46
18		48
19		50

タイムシート





6117  
(B1)  
2  
3

#25-C267

修正原画



A 修  
207  
R  
2  
3



c4



c1

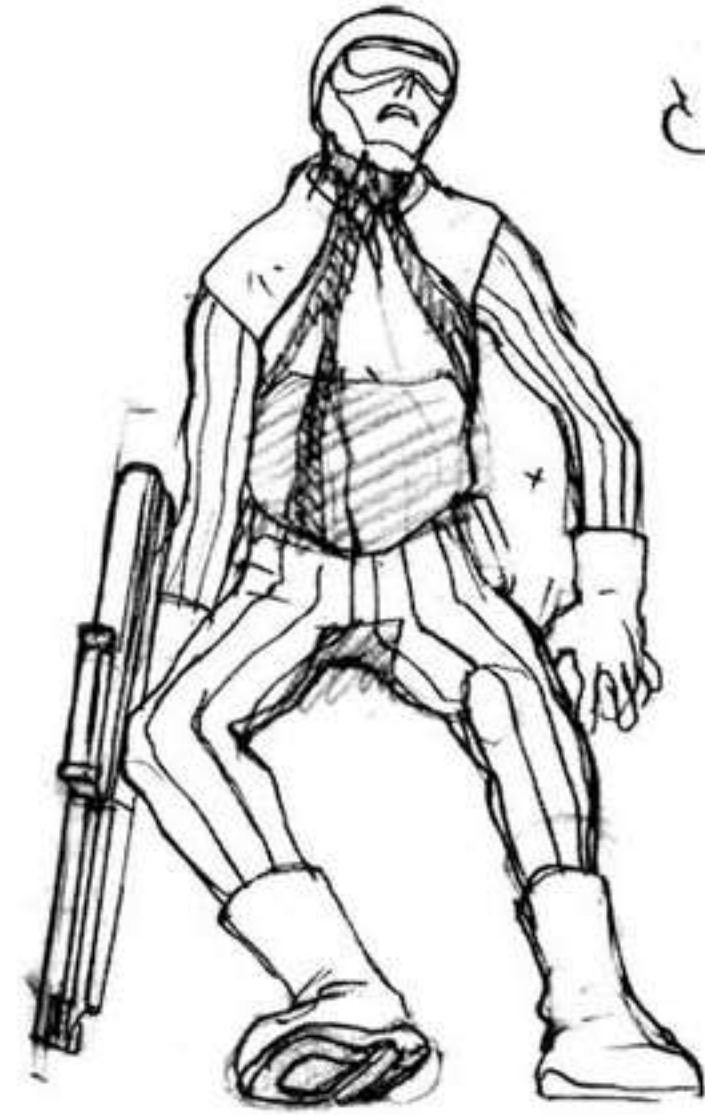

c5

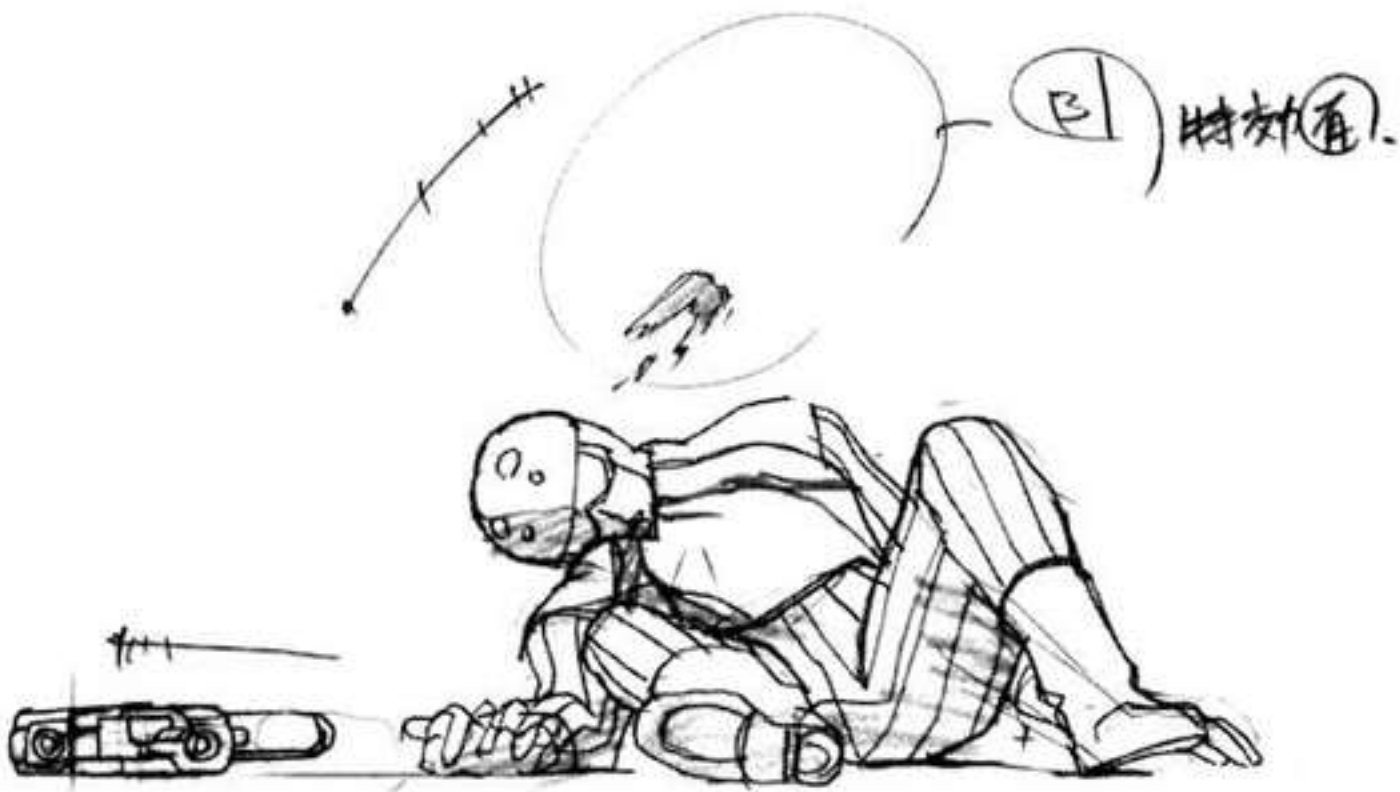

c2

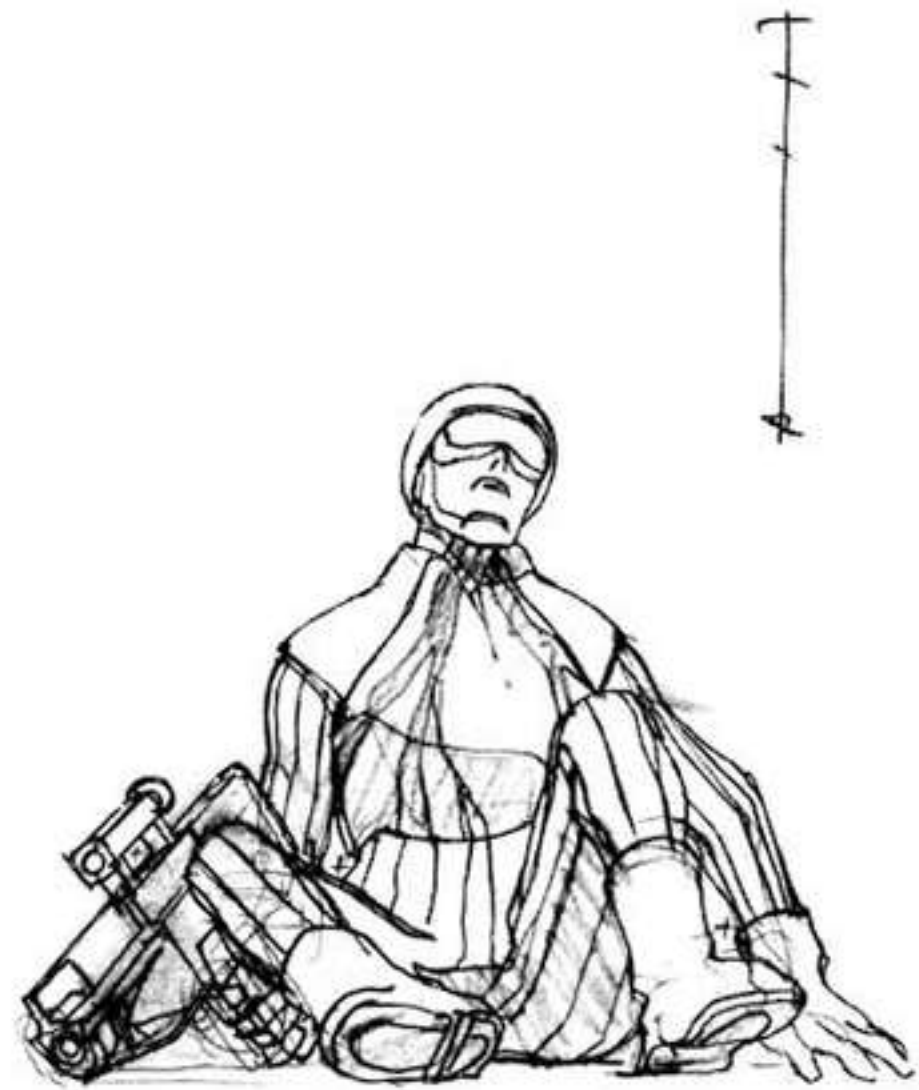

c6



c3







③

④  
①

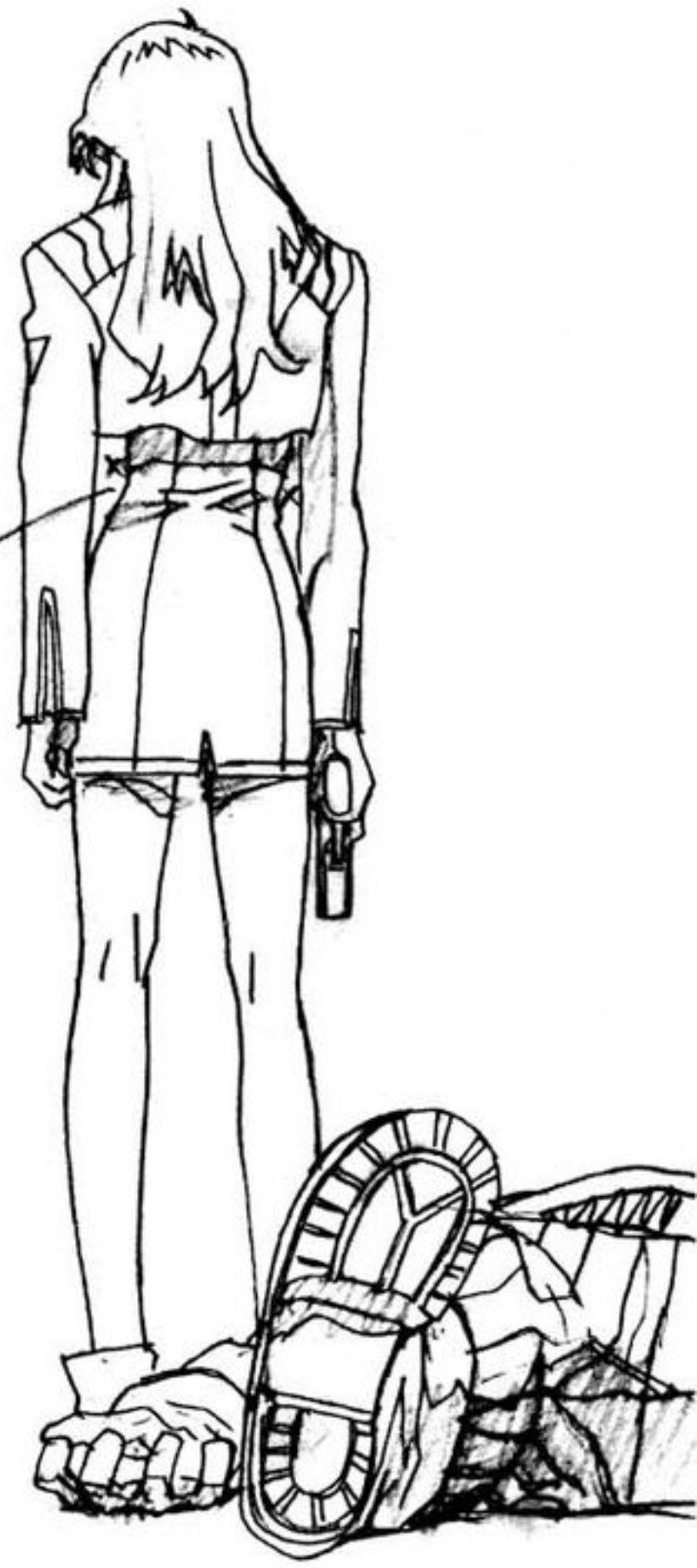

④

A	B	C	D	E
1	2	3	4	5
6	7	8	9	10
11	12	13	14	15
16	17	18	19	20
21	22	23	24	25
26	27	28	29	30
31	32	33	34	35
36	37	38	39	40
41	42	43	44	45
46	47	48	49	50

50
52
54
56
58
60
62
64
66
68
70
72
74
76
78
80
82
84
86
88
90
92
94
96

98
100
102
104
106
108
110
112
114
116
118
120
122
124
126

タイムシート

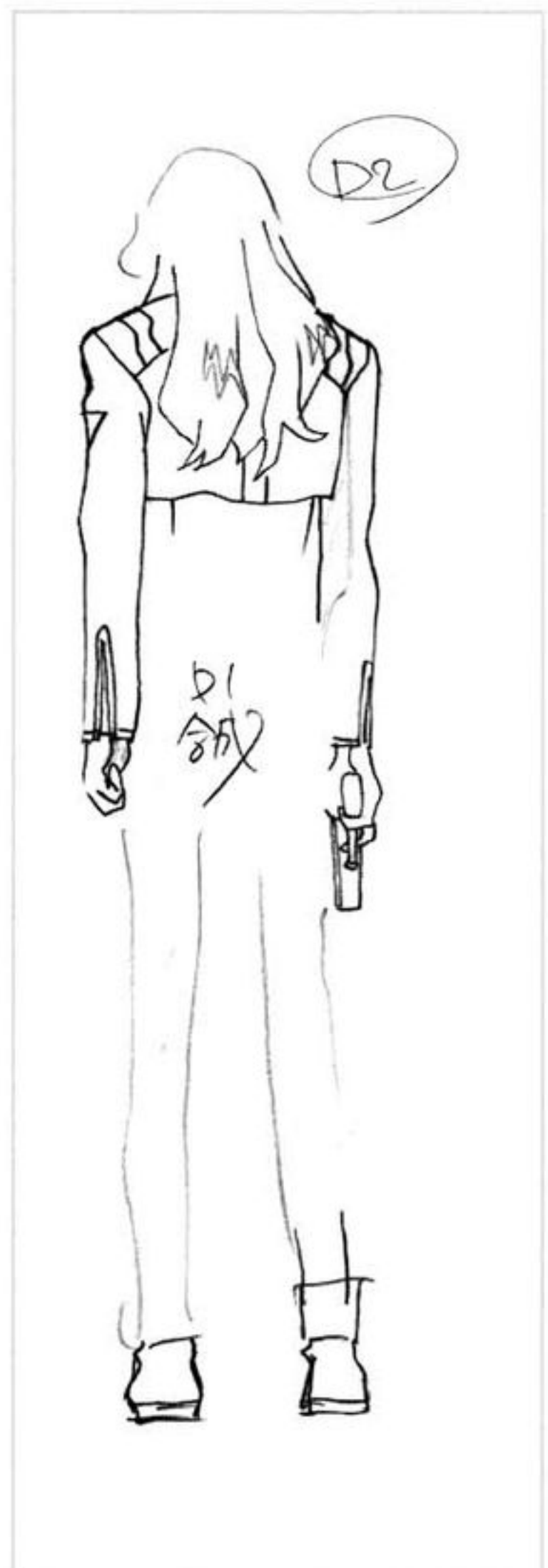
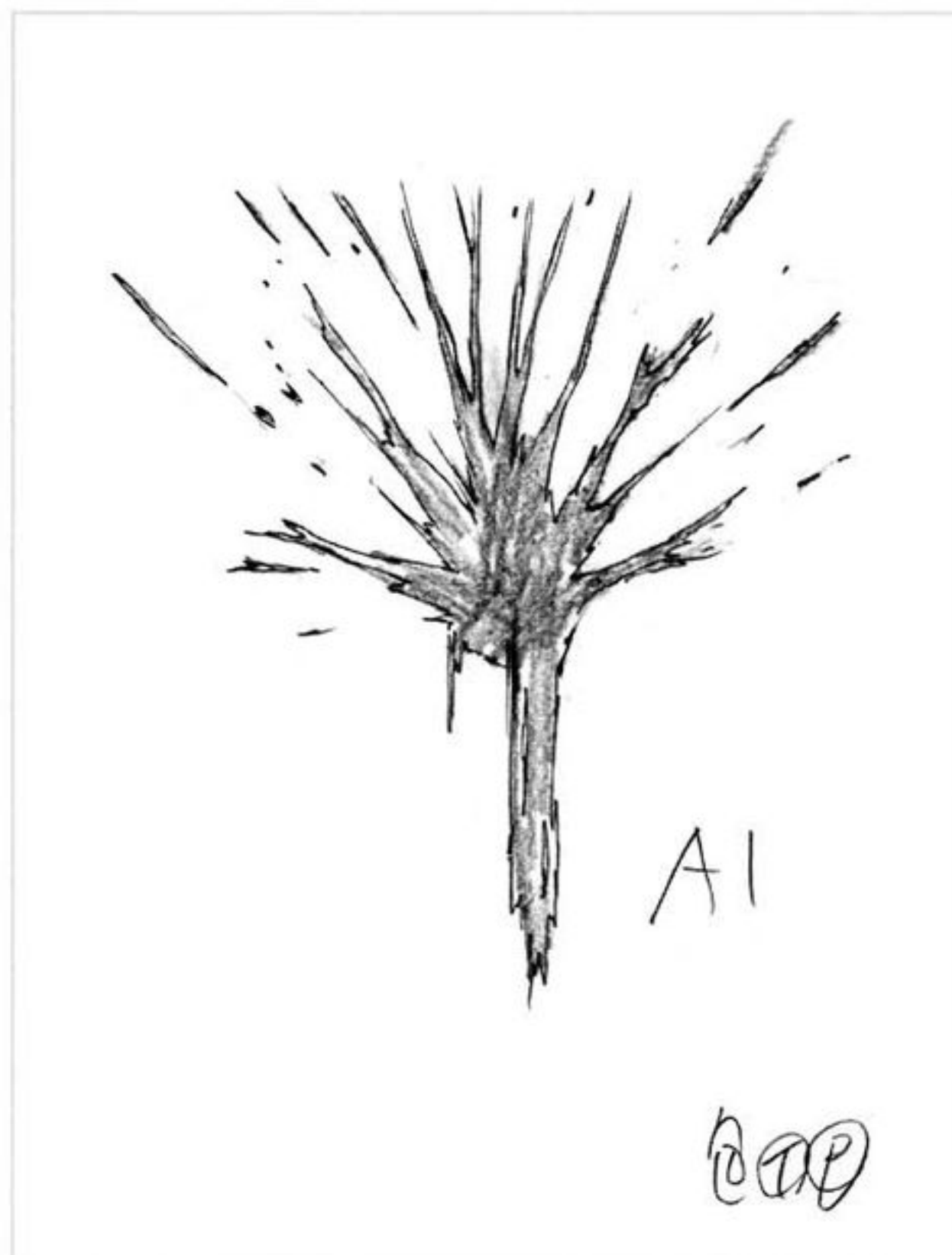



A	B	
1	/	2
1	/	4
1	/	6
2	/	8
1	/	10
3	/	12
1	/	14
1	/	16
1	/	18
4	/	20
1	/	22
1	/	24
1	/	26
1	/	28
5	/	30
6	/	32
7	/	34
1	/	36
1	/	38
1	/	40
1	/	42
8	/	44
1	/	46
1	/	48

タイムシート

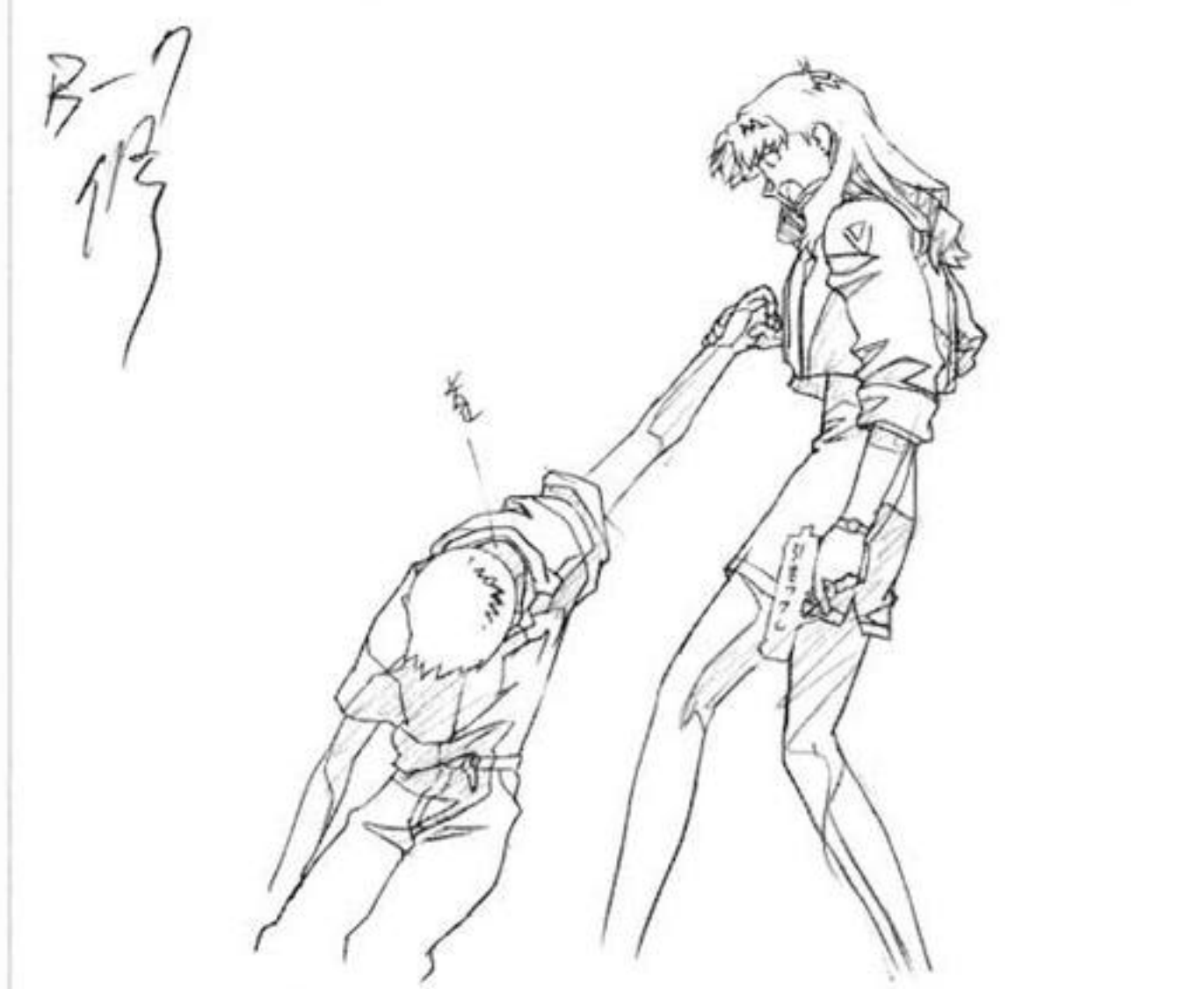





#25-C283

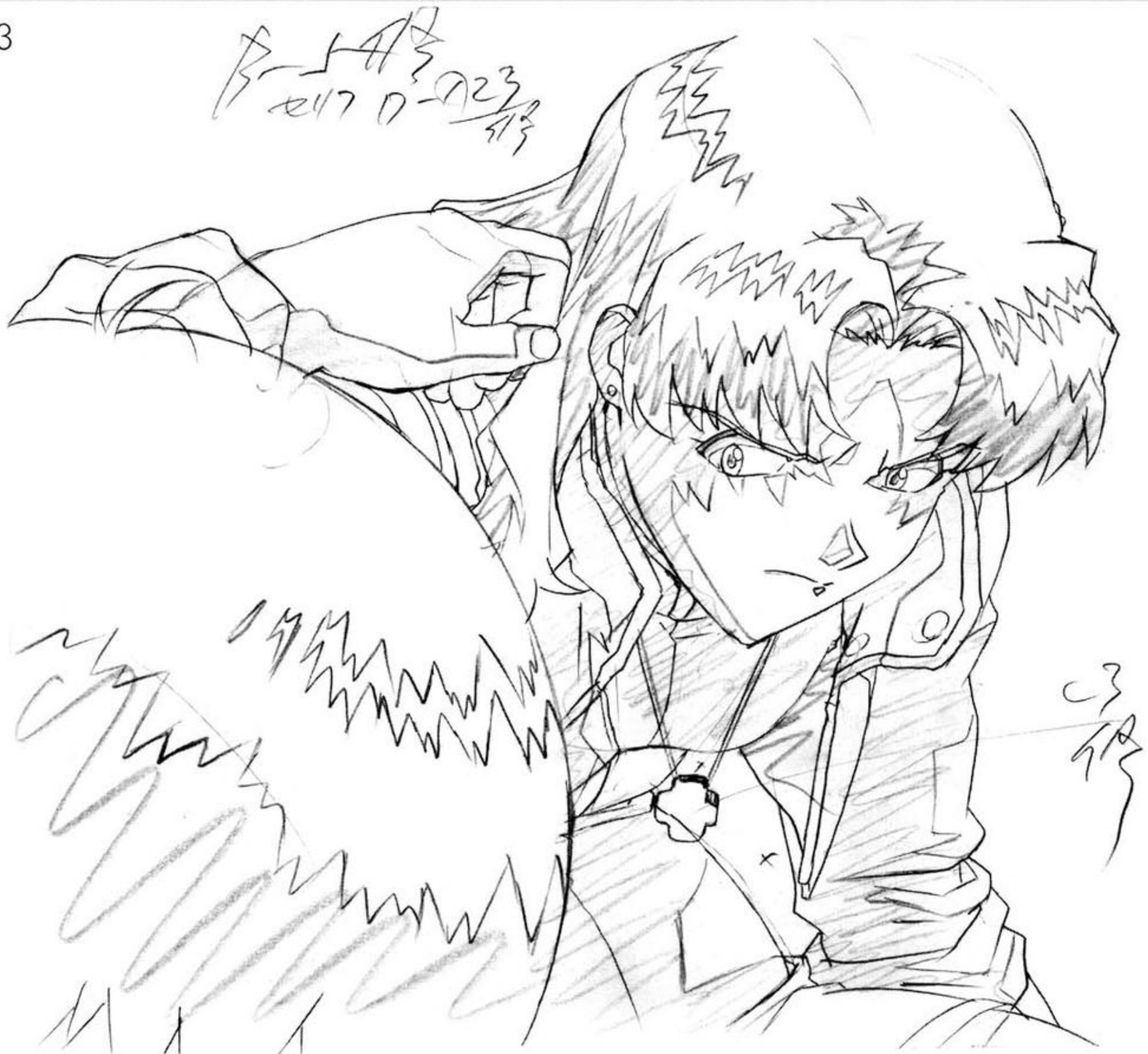



#25-C277

アツ



#25-C284

アツ

アツ





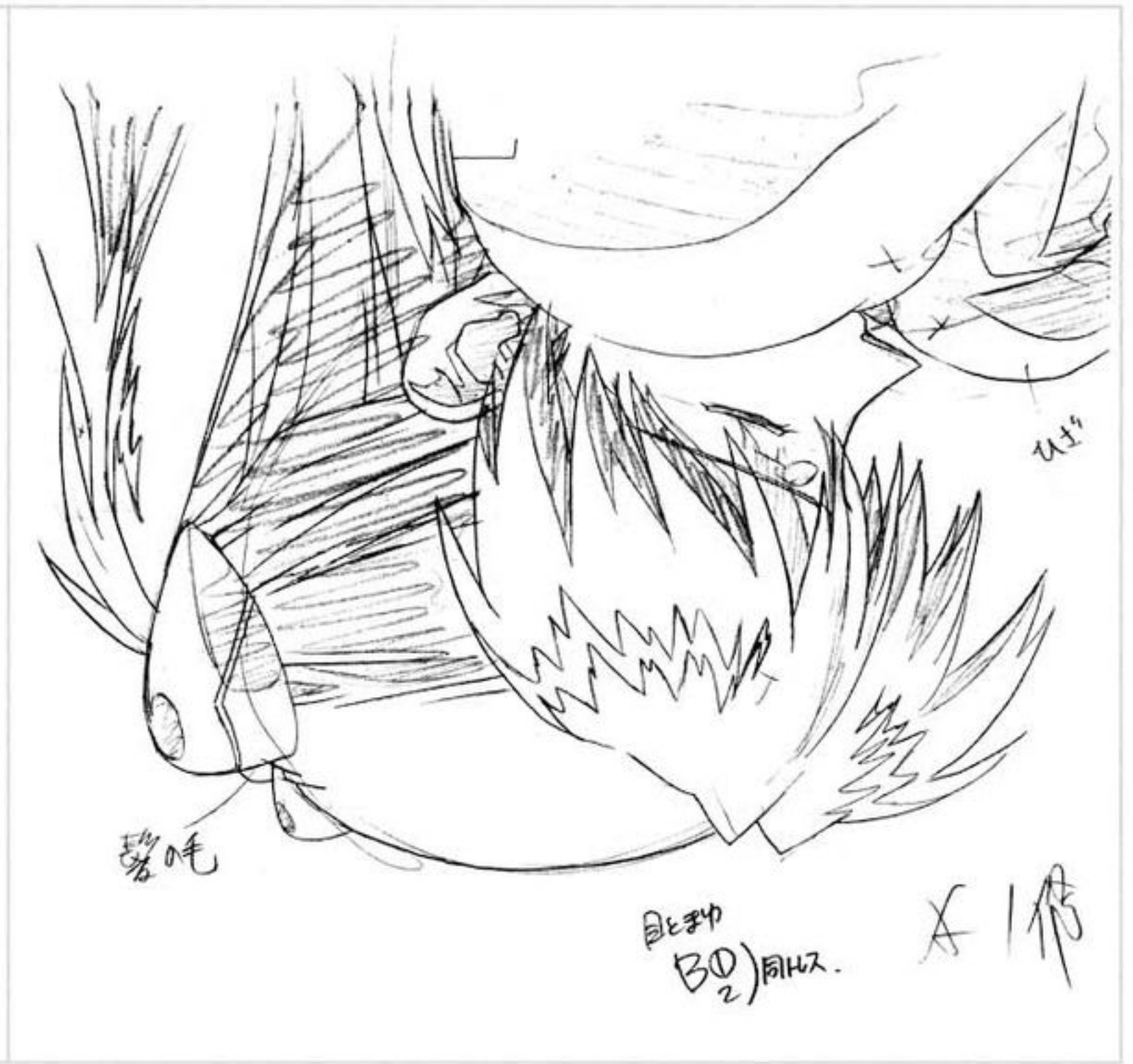
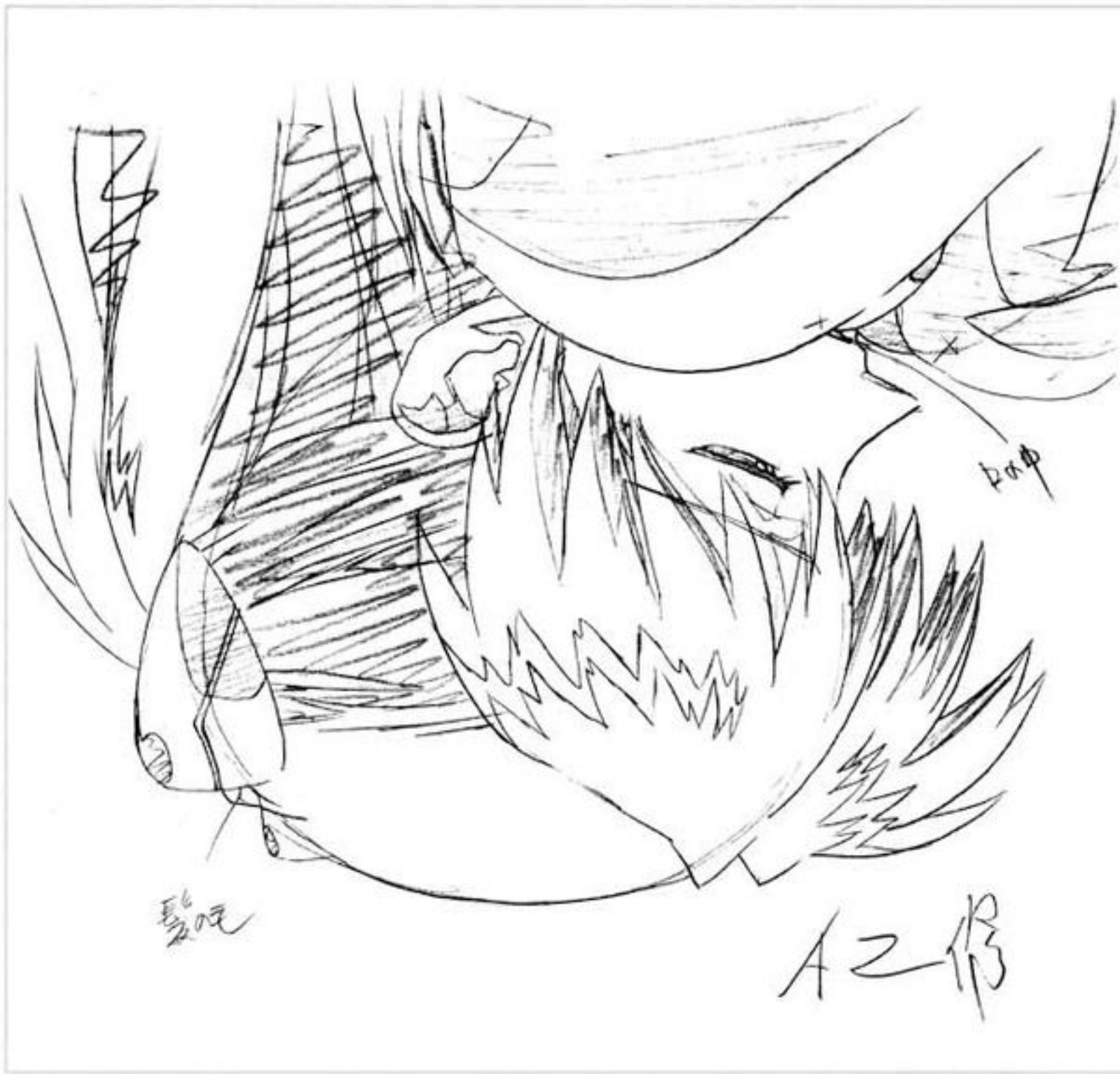

#25-C315

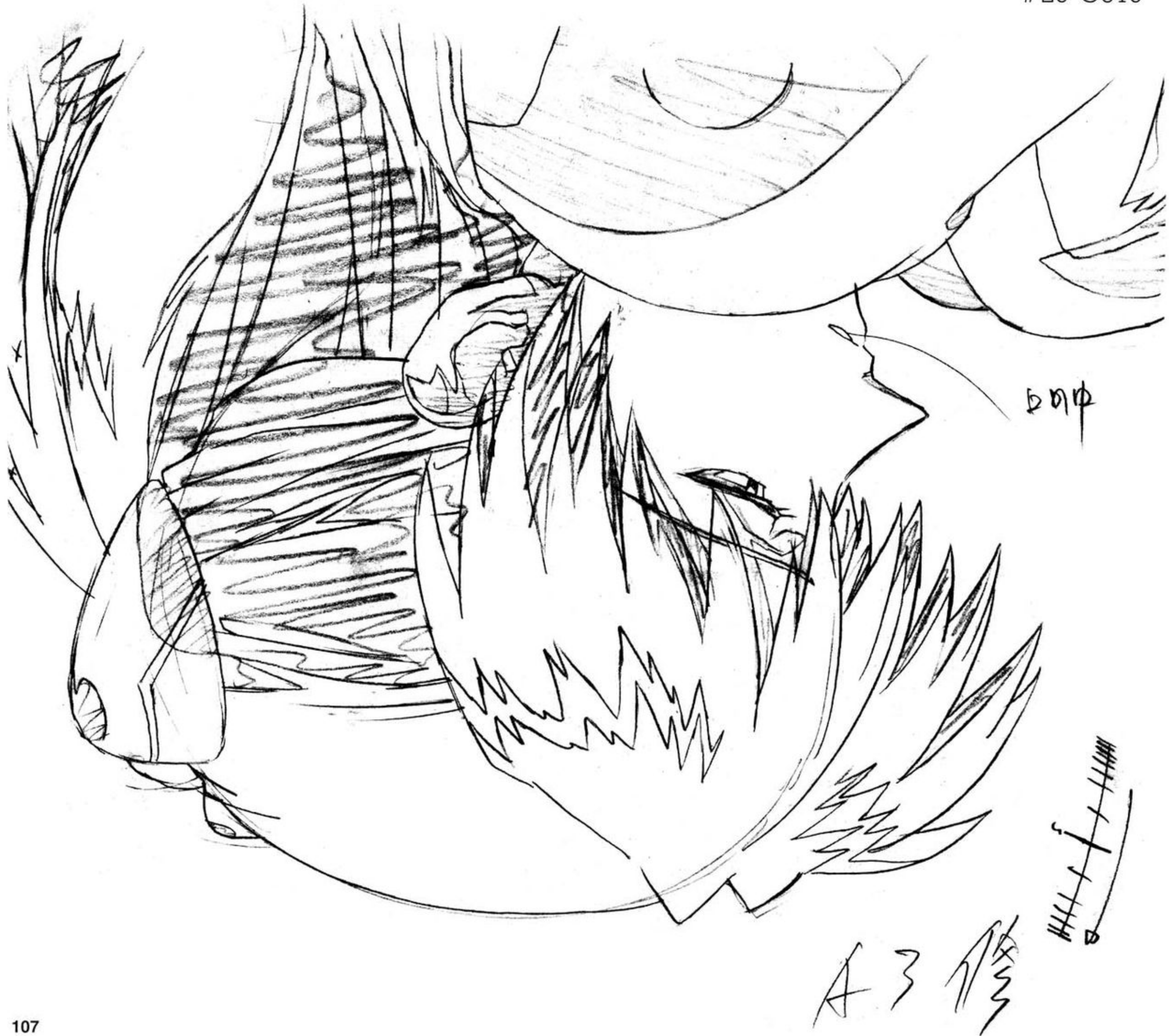





B-11/3

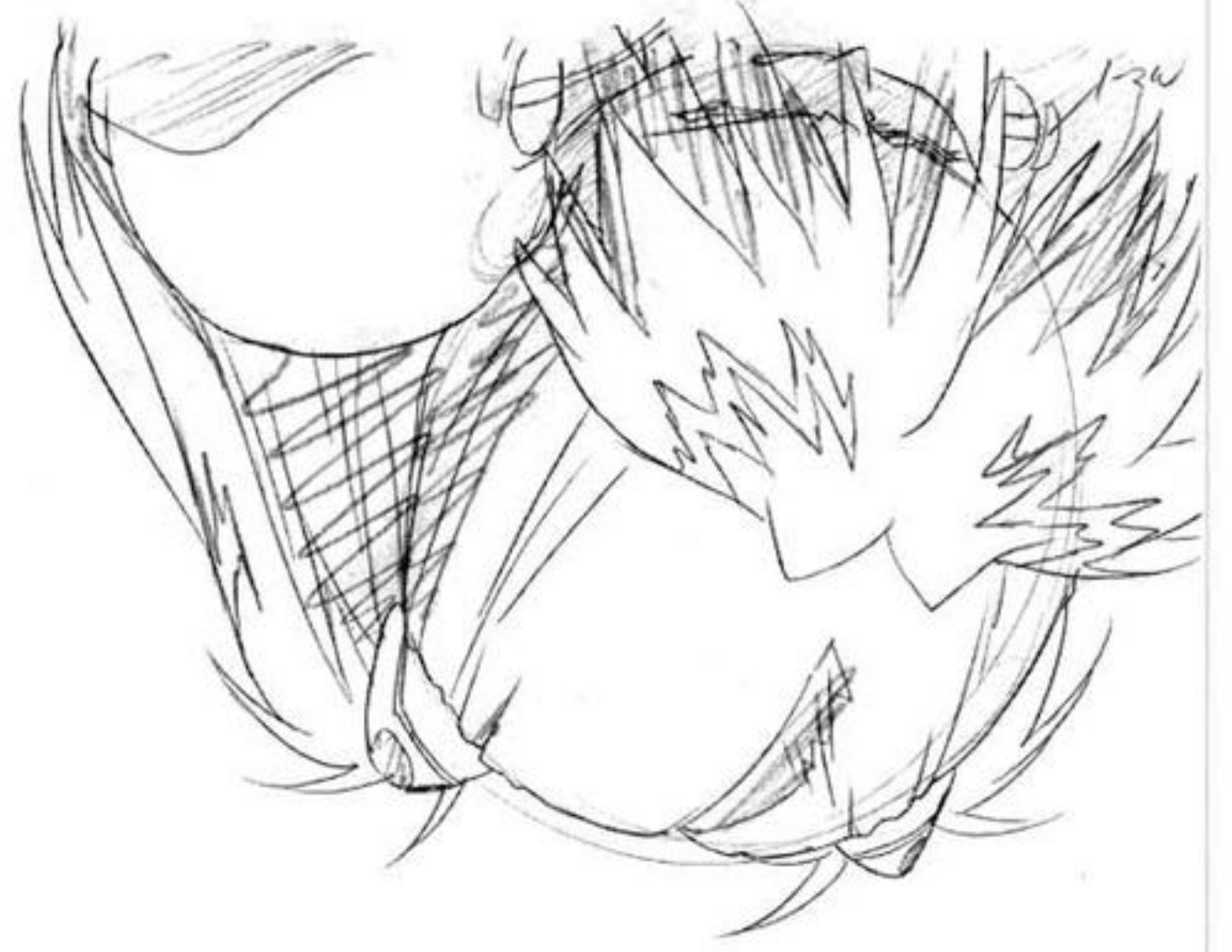

B-11/3

#25-C322

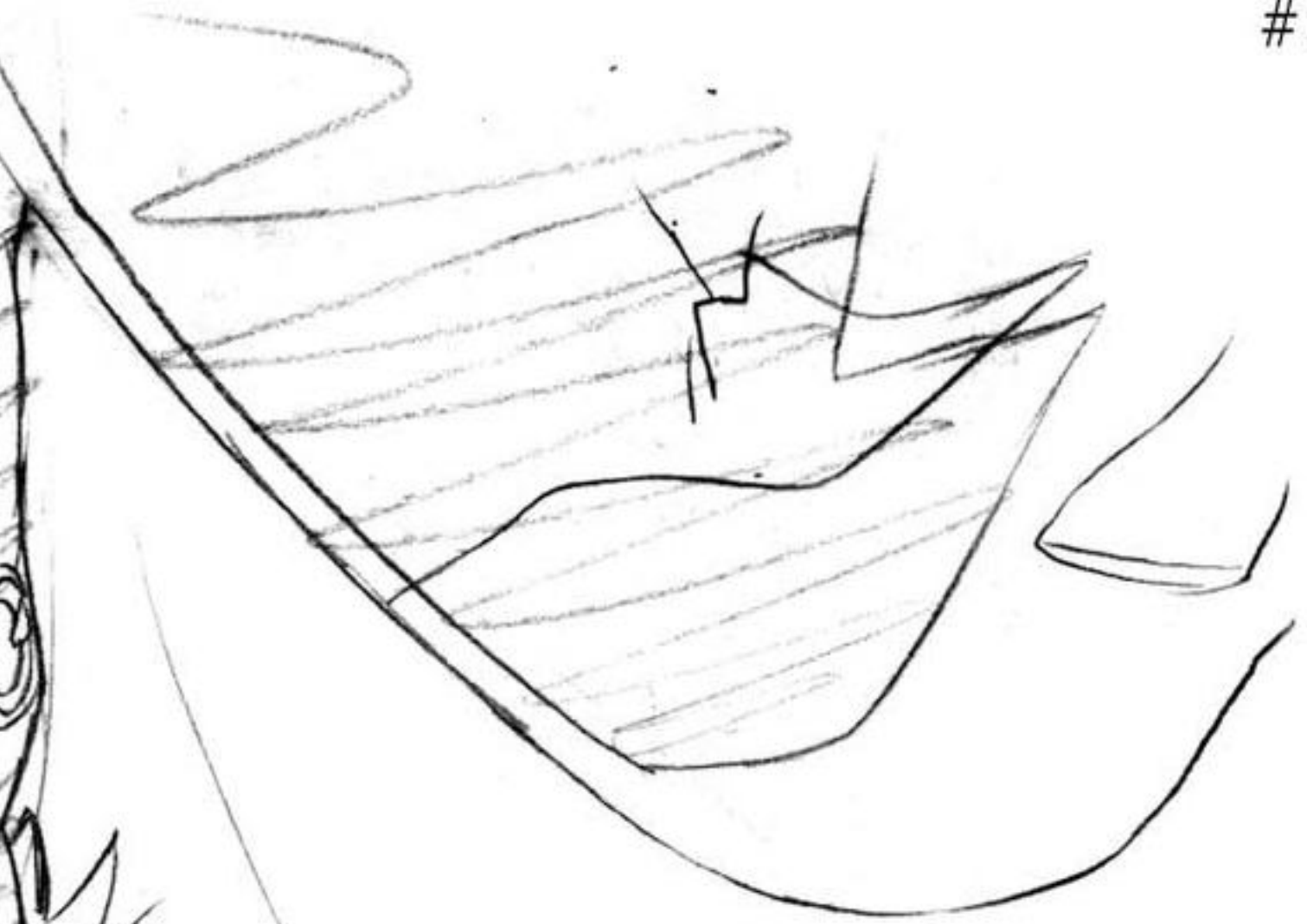

汗  
2枚203A9

B-21/3







A	1		
1	X		
			2
1			4
2			6
			8
			10
			12
			14
			16
			18
			20
			22
			24
			26
3			28
			30
			32
A			34
			36
			38
			40
4			42
5			44
			46
5			48
5			50
5			52
5			54
5			56
5			58
5			60
5			62
5			64
5			66
5			68
5			70
5			72
5			74
5			76
5			78

タイムシート

B-4

脚は.中割

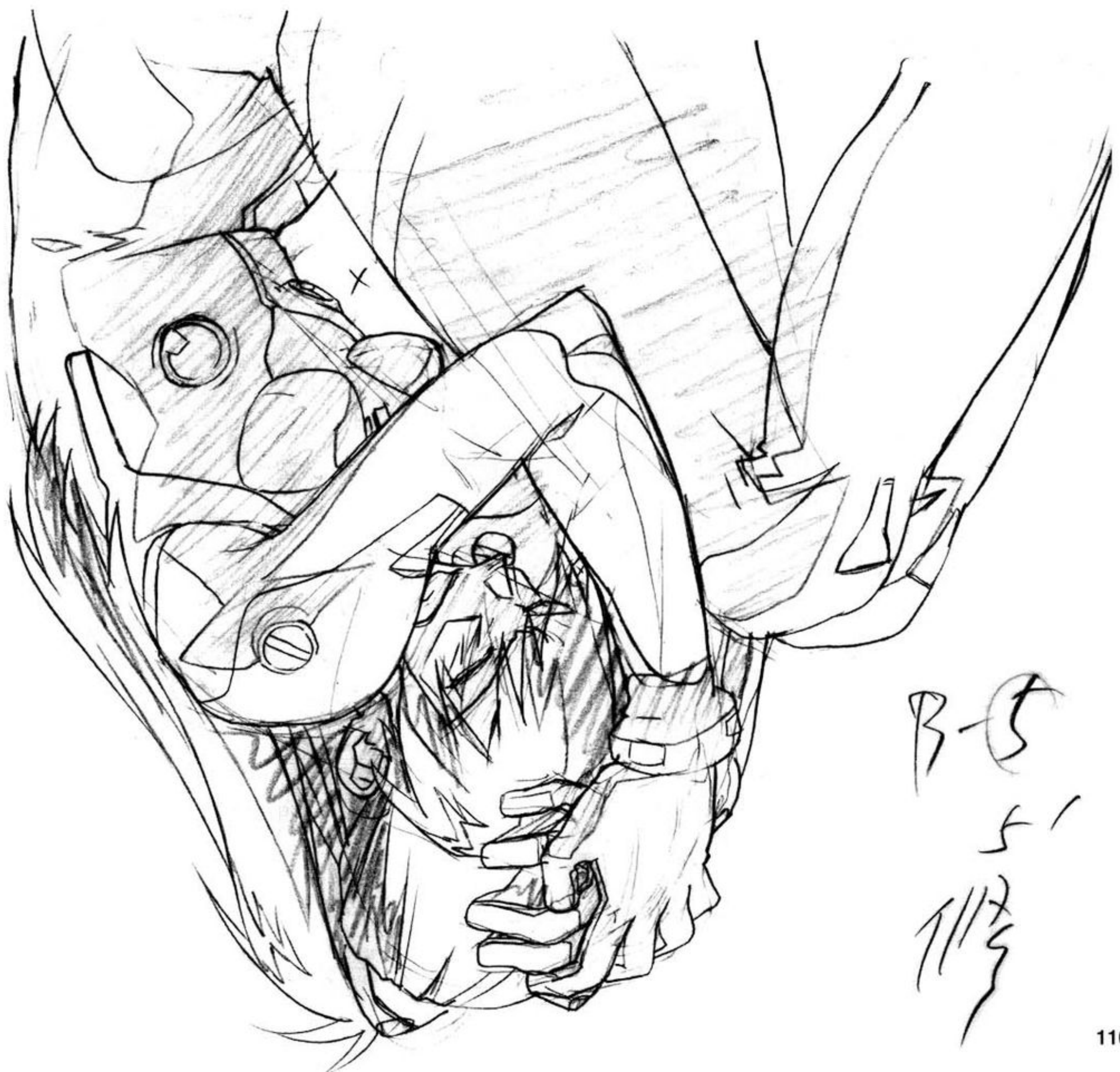

B-5  
5'  
11/3





#25-C332









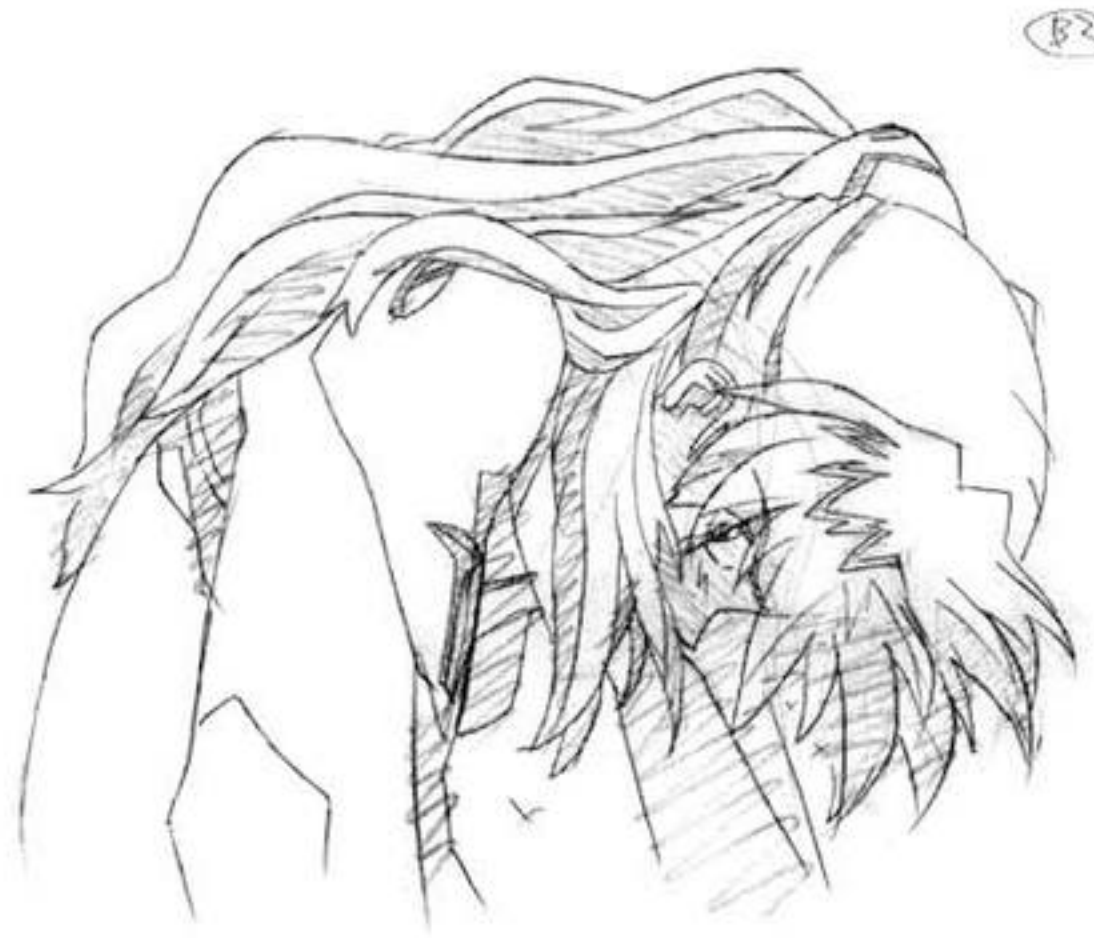

修正原画

B-2 1/2

修正原画

B-1 1/3

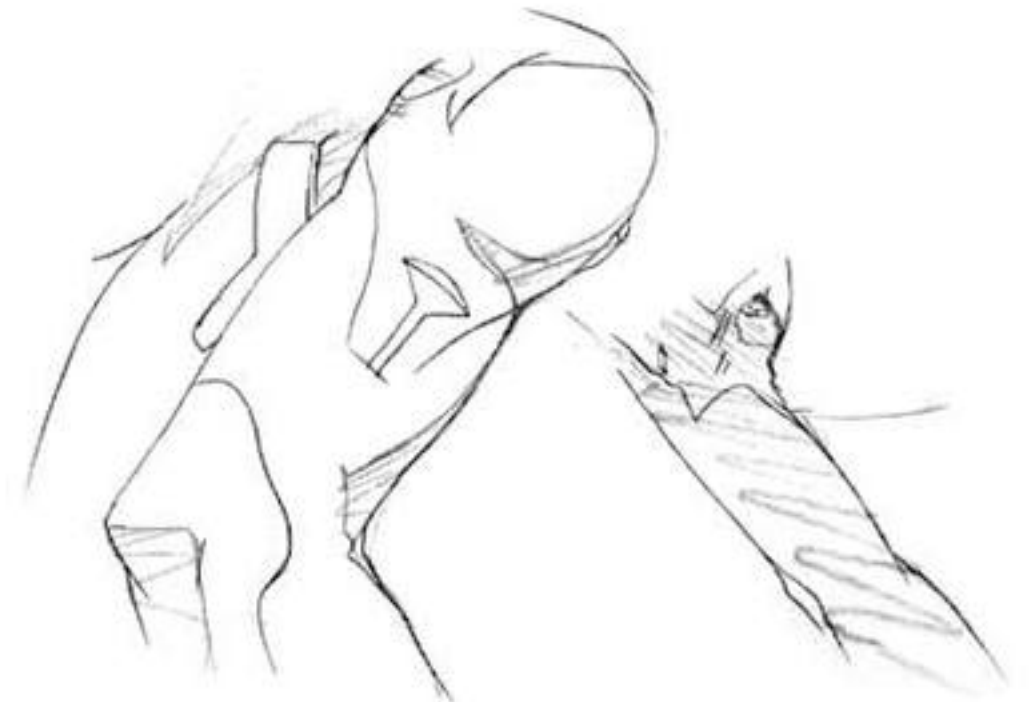

#25-C343





修正原画

B-513

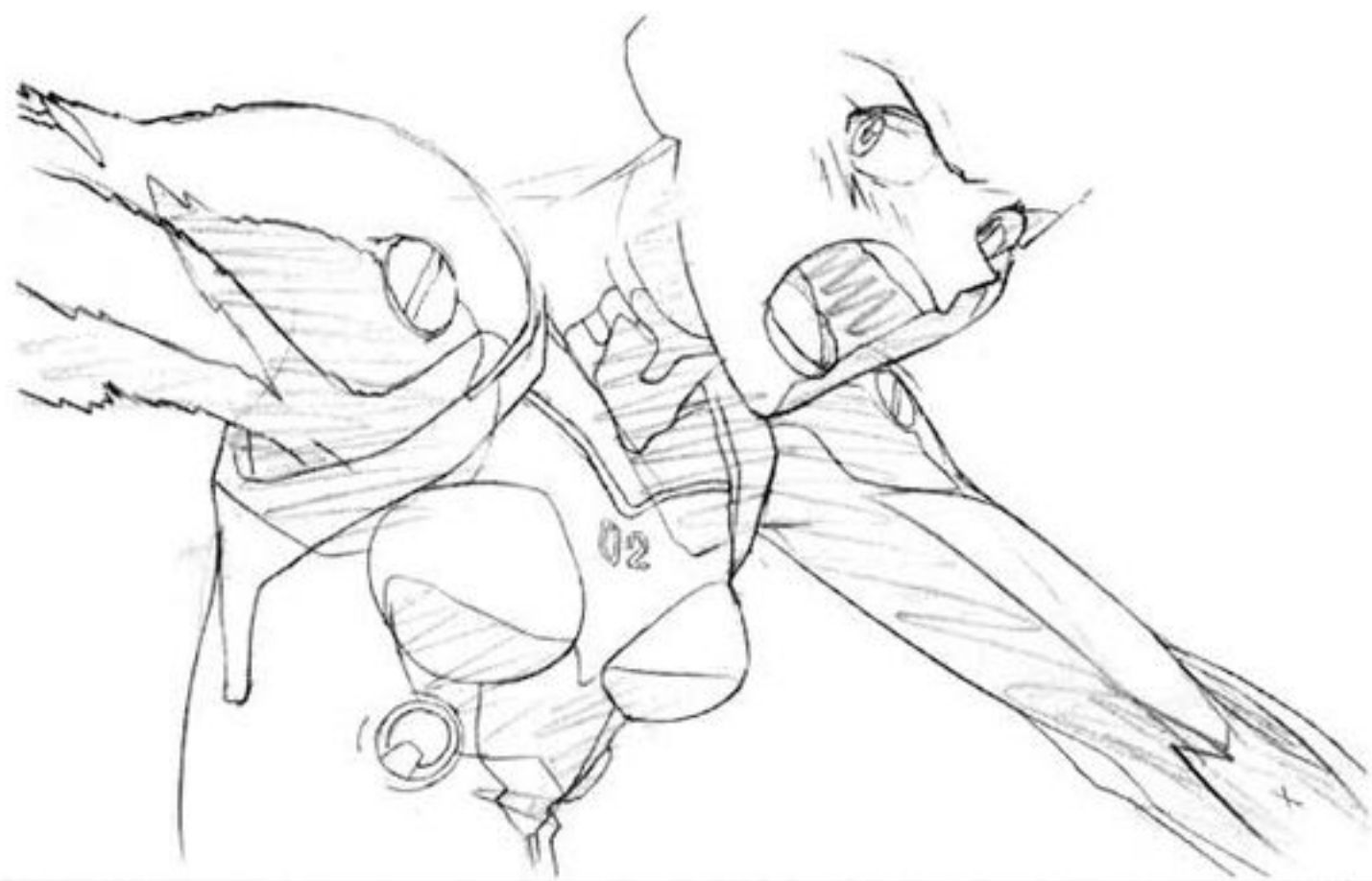

B  
3  
1  
1



修正原画

B-513

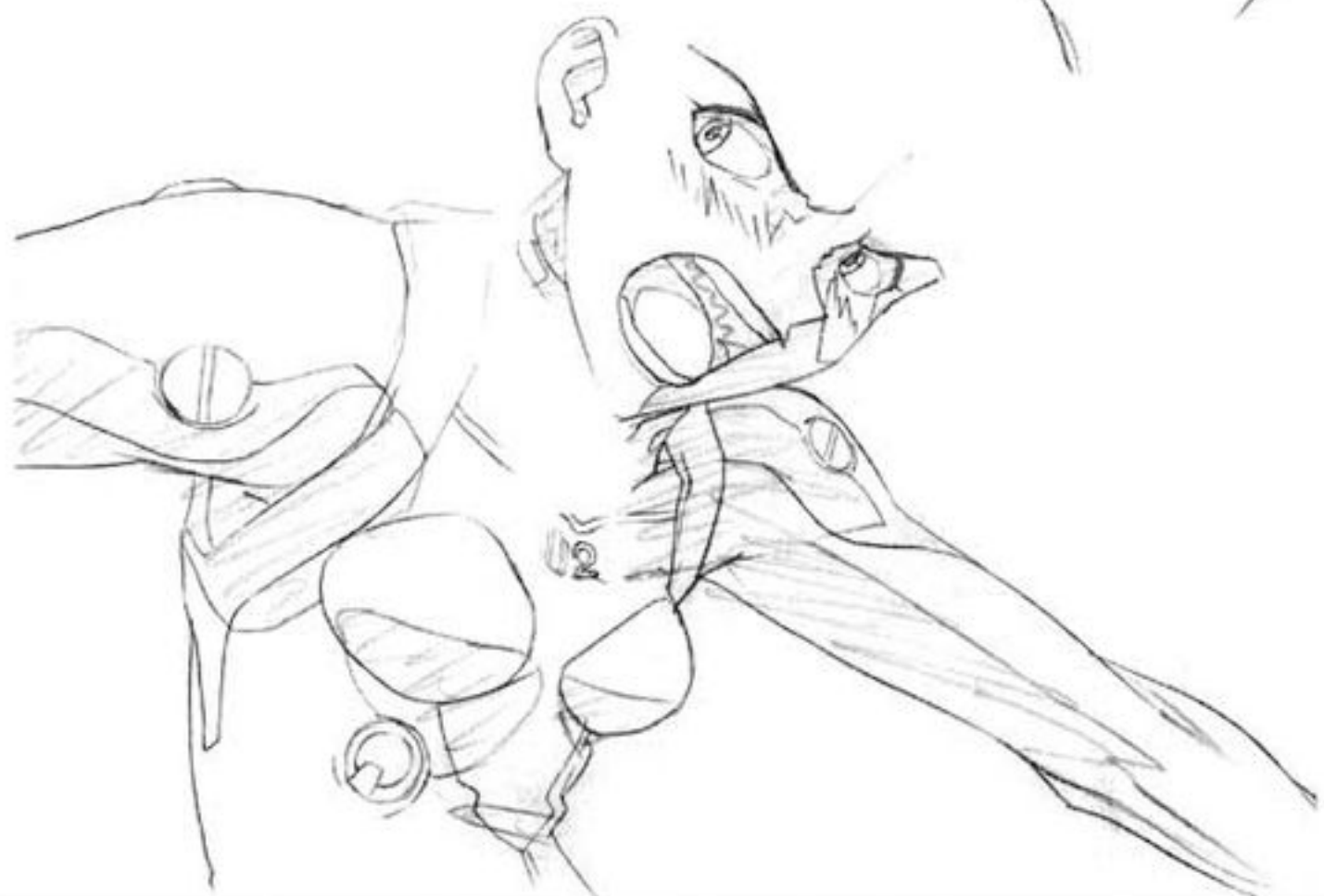

4B	
2/7	
1	2
1	4
1	6
1	8
1	10
1	12
②	14
1	16
1	18
③	20
1	22
④	24
1	26
1	28
1	30
1	32
1	34
⑤	36

#25-C343

B5



髪は12割削りたい

↑  
|||||

タイムシート





A2



A1



A3



A4

A	B	C	D	E	F	G
1	2	3	4	5	6	7
8	9	10	11	12	13	14
15	16	17	18	19	20	21
22	23	24	25	26	27	28
29	30	31	32	33	34	35
36	37	38	39	40	41	42
43	44	45	46	47	48	49
50	51	52	53	54	55	56
57	58	59	60	61	62	63
64	65	66	67	68	69	70
71	72	73	74	75	76	77
78	79	80	81	82	83	84
85	86	87	88	89	90	91
92	93	94	95	96	97	98
99	100	101	102	103	104	105
106	107	108	109	110	111	112
113	114	115	116	117	118	119
120	121	122	123	124	125	126
127	128	129	130	131	132	133
134	135	136	137	138	139	140
141	142	143	144	145	146	147
148	149	150	151	152	153	154
155	156	157	158	159	160	161
162	163	164	165	166	167	168
169	170	171	172	173	174	175
176	177	178	179	180	181	182
183	184	185	186	187	188	189
190	191	192	193	194	195	196
197	198	199	200	201	202	203
204	205	206	207	208	209	210
211	212	213	214	215	216	217
218	219	220	221	222	223	224
225	226	227	228	229	230	231
232	233	234	235	236	237	238
239	240	241	242	243	244	245
246	247	248	249	250	251	252
253	254	255	256	257	258	259
260	261	262	263	264	265	266
267	268	269	270	271	272	273
274	275	276	277	278	279	280
281	282	283	284	285	286	287
288	289	290	291	292	293	294
295	296	297	298	299	300	301
302	303	304	305	306	307	308
309	310	311	312	313	314	315
316	317	318	319	320	321	322
323	324	325	326	327	328	329
330	331	332	333	334	335	336
337	338	339	340	341	342	343
344	345	346	347	348	349	350
351	352	353	354	355	356	357
358	359	360	361	362	363	364
365	366	367	368	369	370	371
372	373	374	375	376	377	378
379	380	381	382	383	384	385
386	387	388	389	390	391	392
393	394	395	396	397	398	399
400	401	402	403	404	405	406
407	408	409	410	411	412	413
414	415	416	417	418	419	420
421	422	423	424	425	426	427
428	429	430	431	432	433	434
435	436	437	438	439	440	441
442	443	444	445	446	447	448
449	450	451	452	453	454	455
456	457	458	459	460	461	462
463	464	465	466	467	468	469
470	471	472	473	474	475	476
477	478	479	480	481	482	483
484	485	486	487	488	489	490
491	492	493	494	495	496	497
498	499	500	501	502	503	504
505	506	507	508	509	510	511
512	513	514	515	516	517	518
519	520	521	522	523	524	525
526	527	528	529	530	531	532
533	534	535	536	537	538	539
540	541	542	543	544	545	546
547	548	549	550	551	552	553
554	555	556	557	558	559	560
561	562	563	564	565	566	567
568	569	570	571	572	573	574
575	576	577	578	579	580	581
582	583	584	585	586	587	588
589	590	591	592	593	594	595
596	597	598	599	600	601	602
603	604	605	606	607	608	609
610	611	612	613	614	615	616
617	618	619	620	621	622	623
624	625	626	627	628	629	630
631	632	633	634	635	636	637
638	639	640	641	642	643	644
645	646	647	648	649	650	651
652	653	654	655	656	657	658
659	660	661	662	663	664	665
666	667	668	669	670	671	672
673	674	675	676	677	678	679
680	681	682	683	684	685	686
687	688	689	690	691	692	693
694	695	696	697	698	699	700
701	702	703	704	705	706	707
708	709	710	711	712	713	714
715	716	717	718	719	720	721
722	723	724	725	726	727	728
729	730	731	732	733	734	735
736	737	738	739	740	741	742
743	744	745	746	747	748	749
750	751	752	753	754	755	756
757	758	759	760	761	762	763
764	765	766	767	768	769	770
771	772	773	774	775	776	777
778	779	780	781	782	783	784
785	786	787	788	789	790	791
792	793	794	795	796	797	798
799	800	801	802	803	804	805
806	807	808	809	810	811	812
813	814	815	816	817	818	819
820	821	822	823	824	825	826
827	828	829	830	831	832	833
834	835	836	837	838	839	840
841	842	843	844	845	846	847
848	849	850	851	852	853	854
855	856	857	858	859	860	861
862	863	864	865	866	867	868
869	870	871	872	873	874	875
876	877	878	879	880	881	882
883	884	885	886	887	888	889
890	891	892	893	894	895	896
897	898	899	900	901	902	903
904	905	906	907	908	909	910
911	912	913	914	915	916	917
918	919	920	921	922	923	924
925	926	927	928	929	930	931
932	933	934	935	936	937	938
939	940	941	942	943	944	945
946	947	948	949	950	951	952
953	954	955	956	957	958	959
960	961	962	963	964	965	966
967	968	969	970	971	972	973
974	975	976	977	978	979	980
981	982	983	984	985	986	987
988	989	990	991	992	993	994
995	996	997	998	999	1000	1001

#25-C344

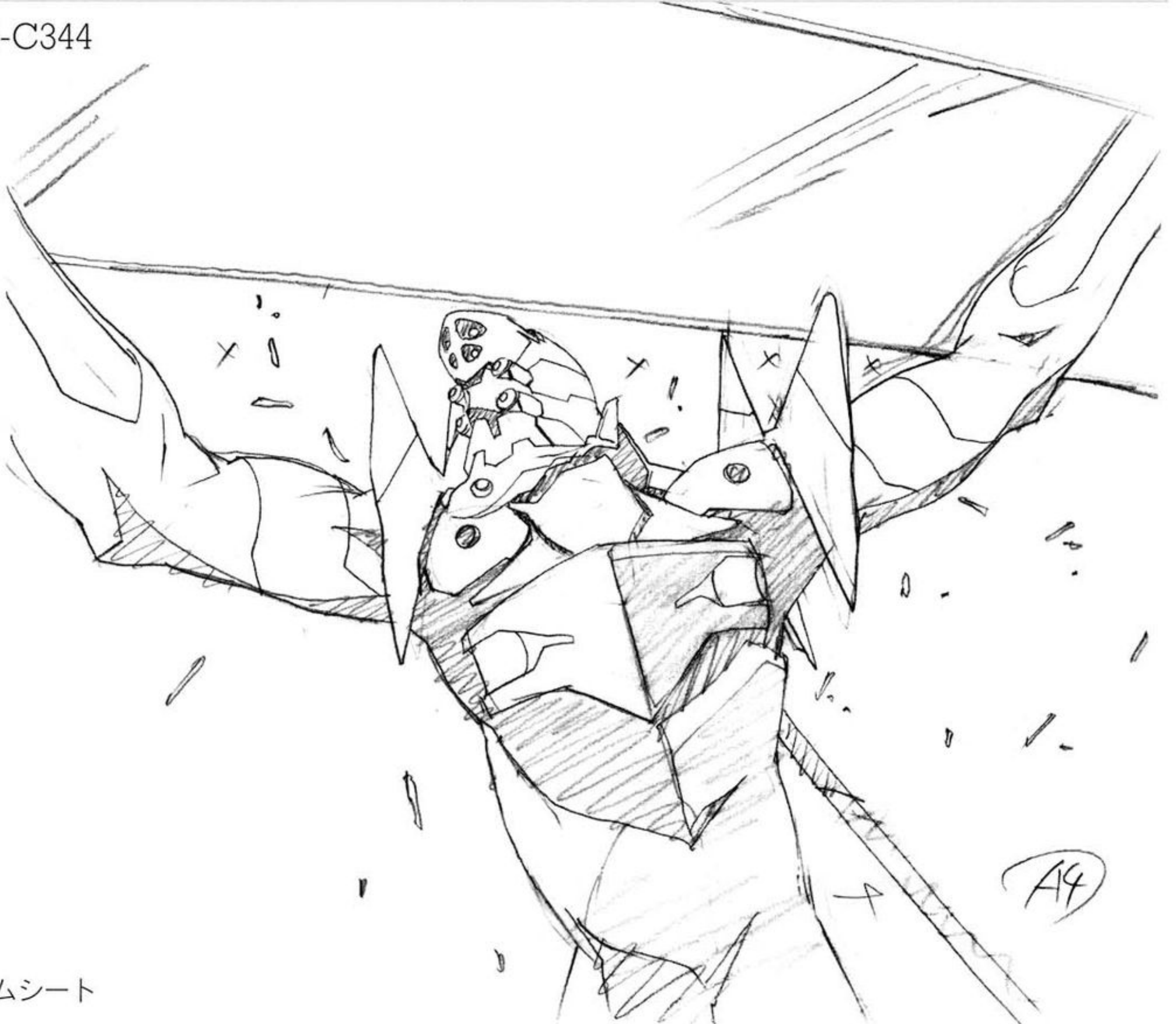

A4

タイムシート



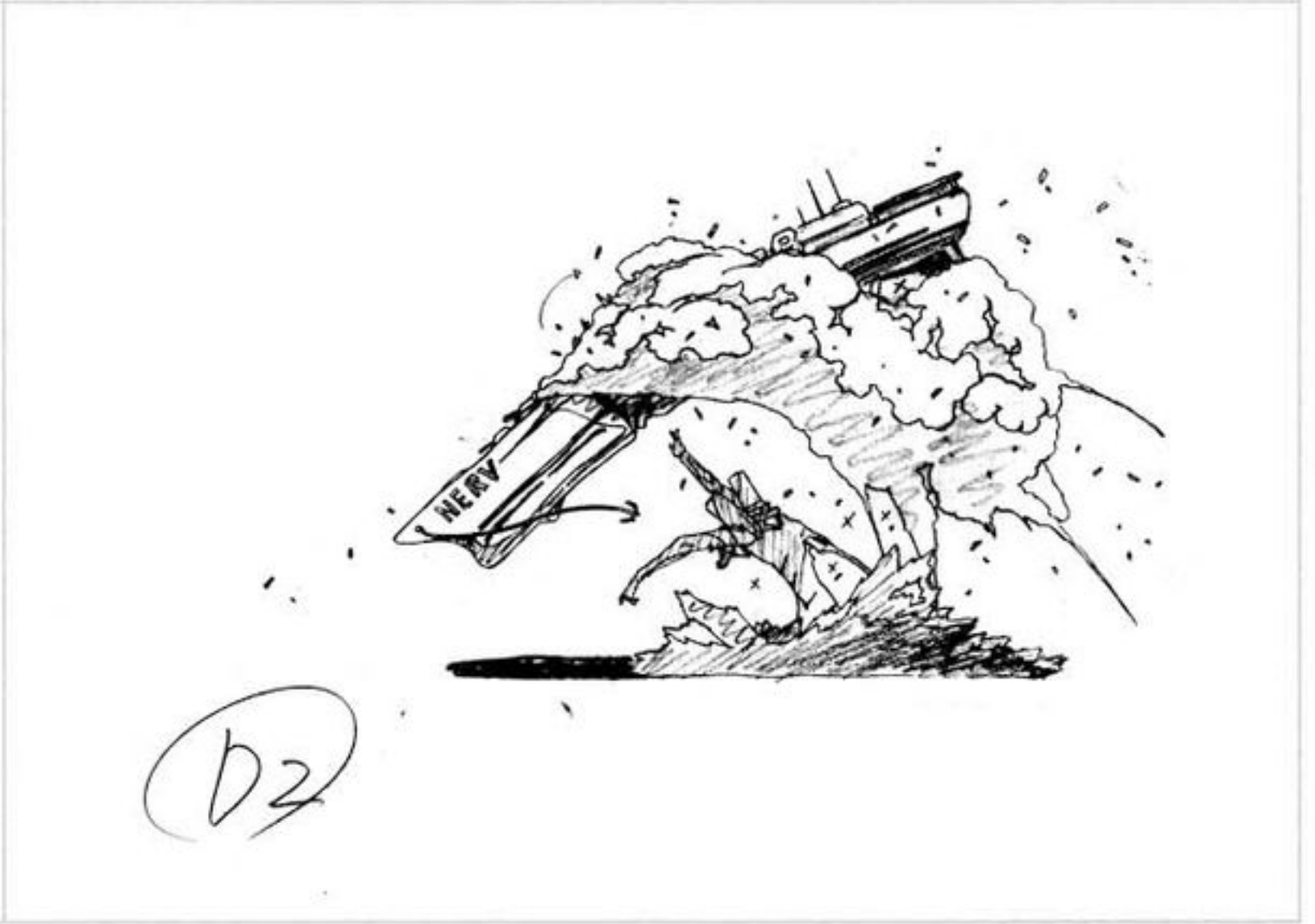
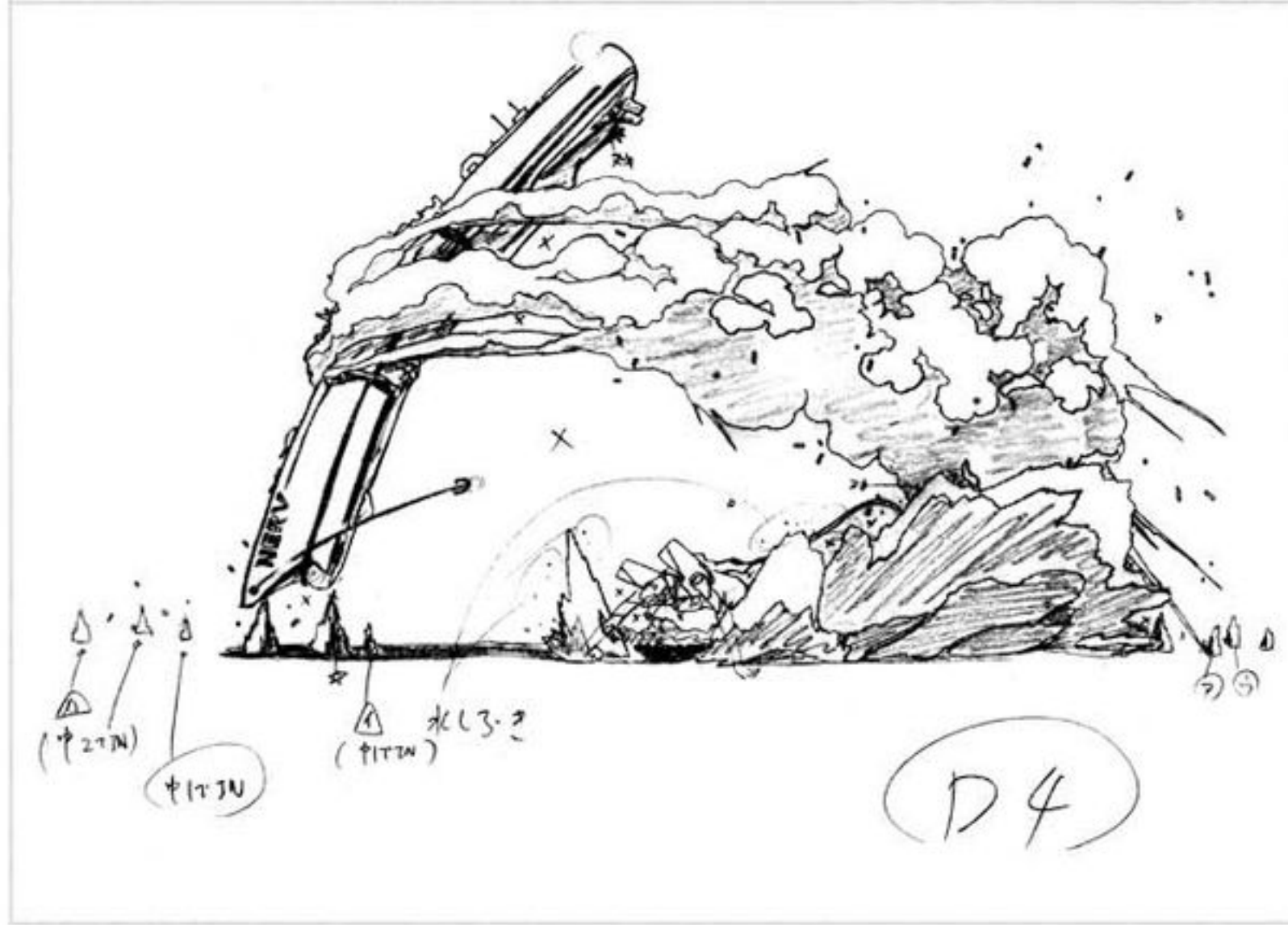
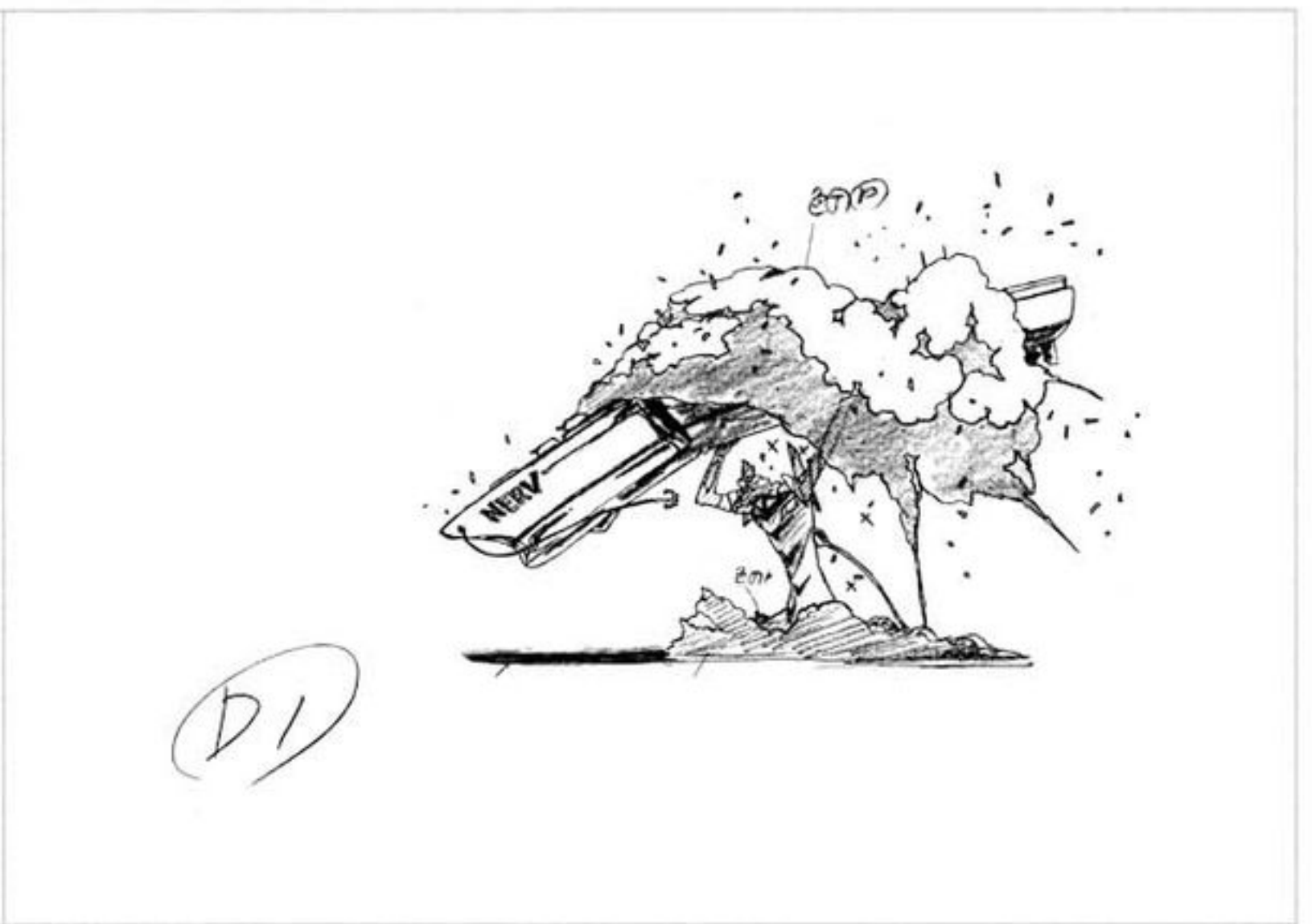
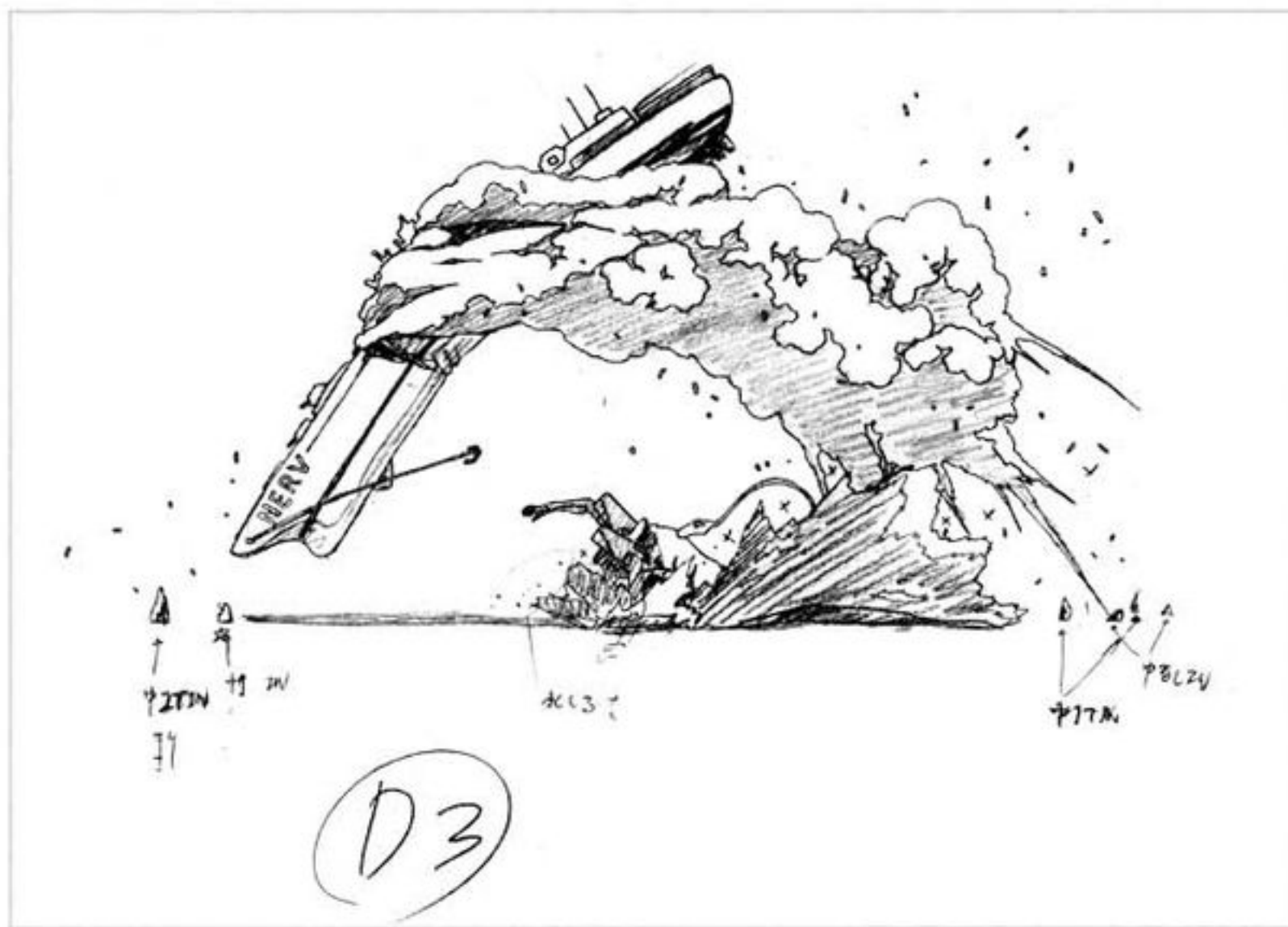

#25-C345

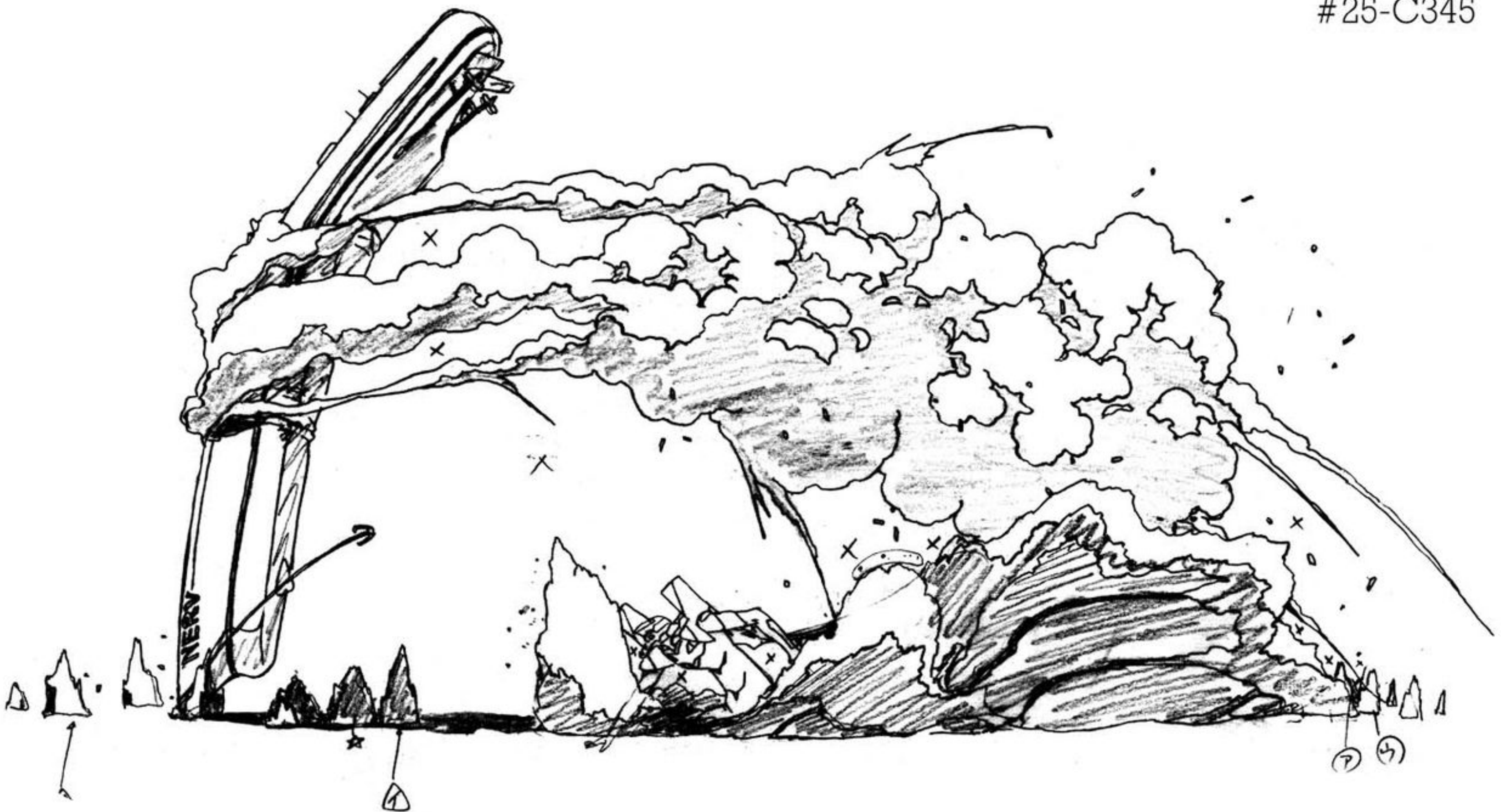

D5 *and*







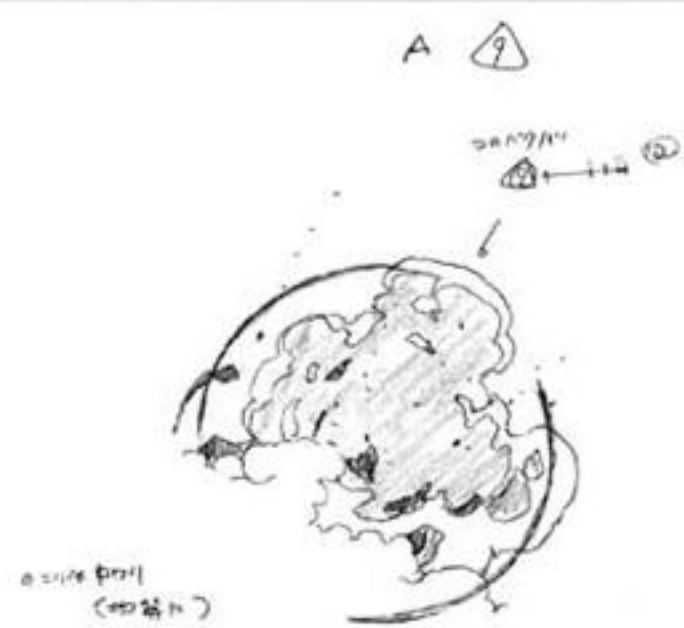

A ⑫ END

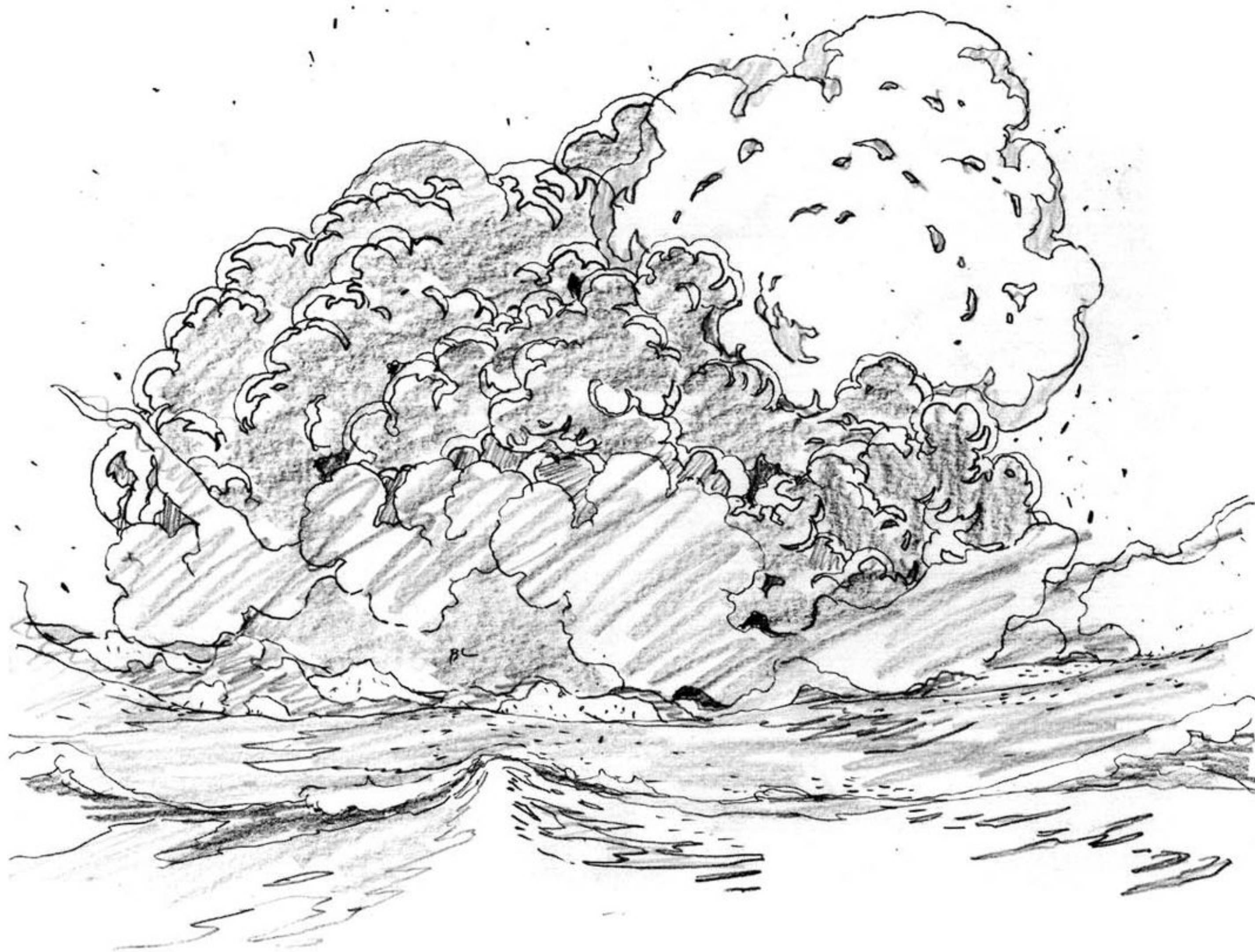



A	B	C	
○	X	X	2
			4
			6
			8
			10
			12
			14
			16
△	②		18
			20
			22
			24
			26
			28
			30
			32
			34
			36
②	⑤		38
			40
			42
			44
			46
			48
			50
			52
			54
⑤	⑦		56
			58
			60
			62
			64
			66
			68
			70
			72

タイムシート

A	B	C	
		X	74
	X		76
			78
			80
③			82
	②		84
④	③	X	86
⑤	⑥		88
⑦	④		90
⑧	⑤	X	92
⑨			94
			96
			98
			100
			102
			104
			106
			108
⑩			110
			112
			114
			116
			118
			120
			122
			124
			126
			128
⑪			130
			132

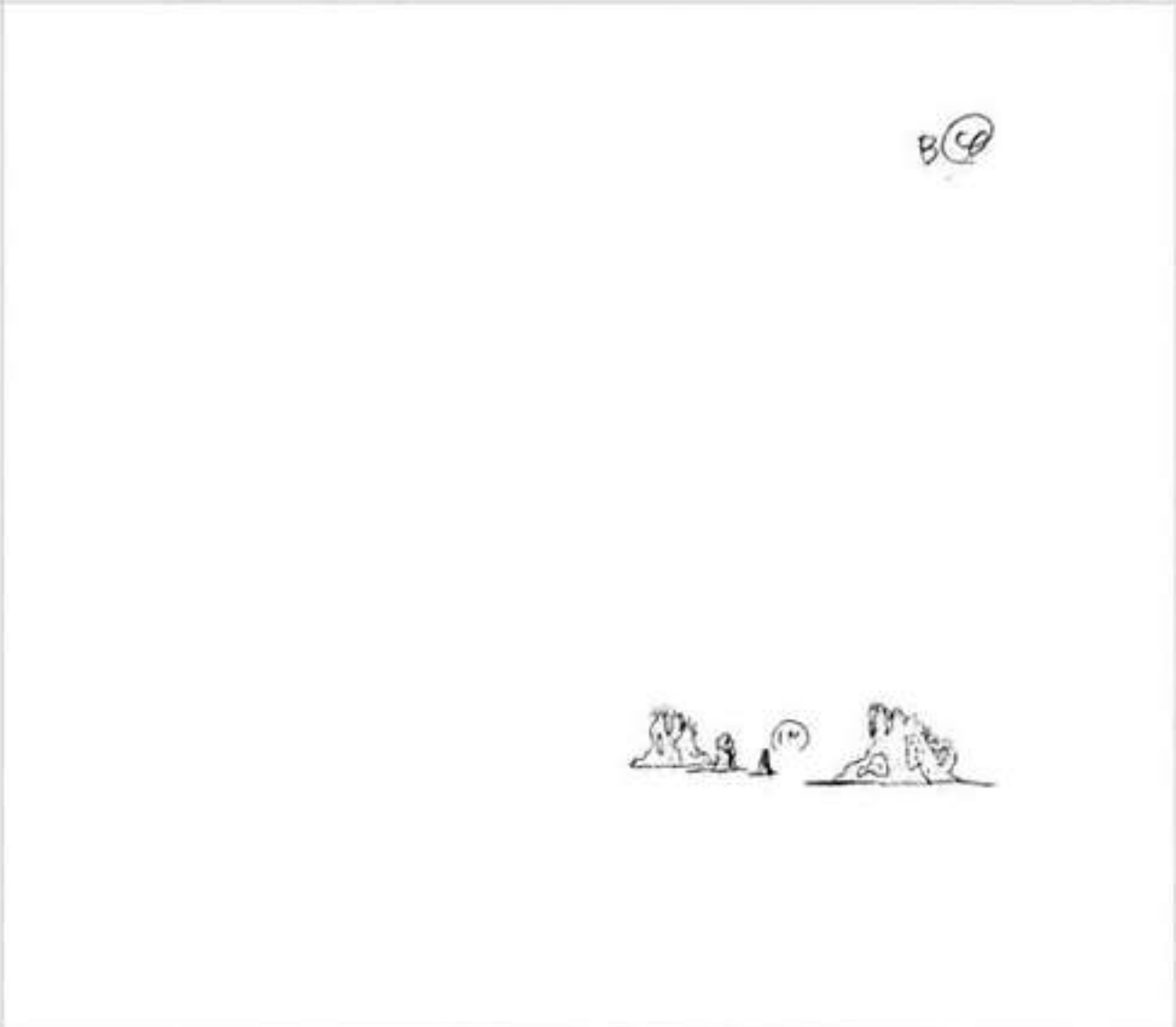
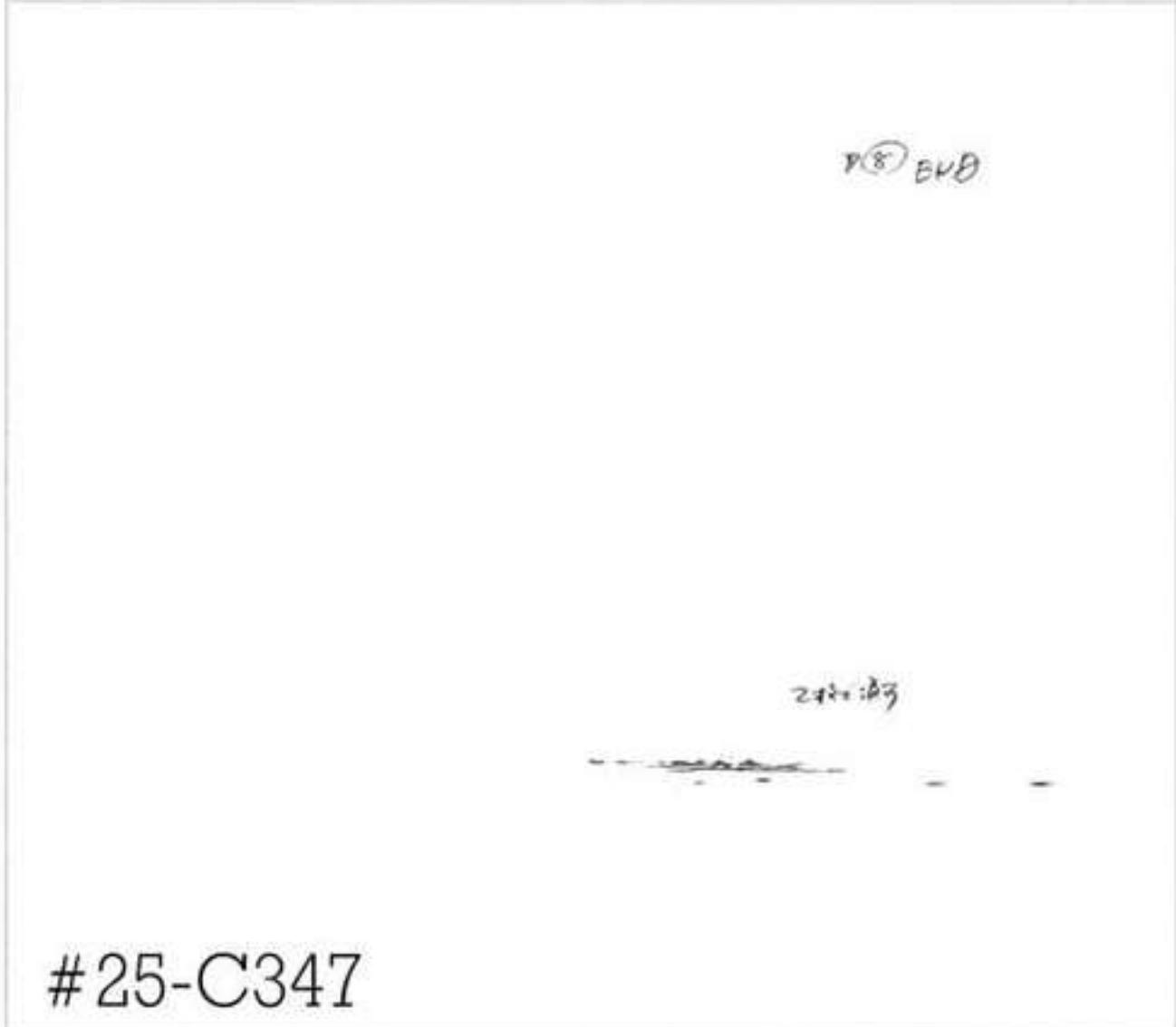
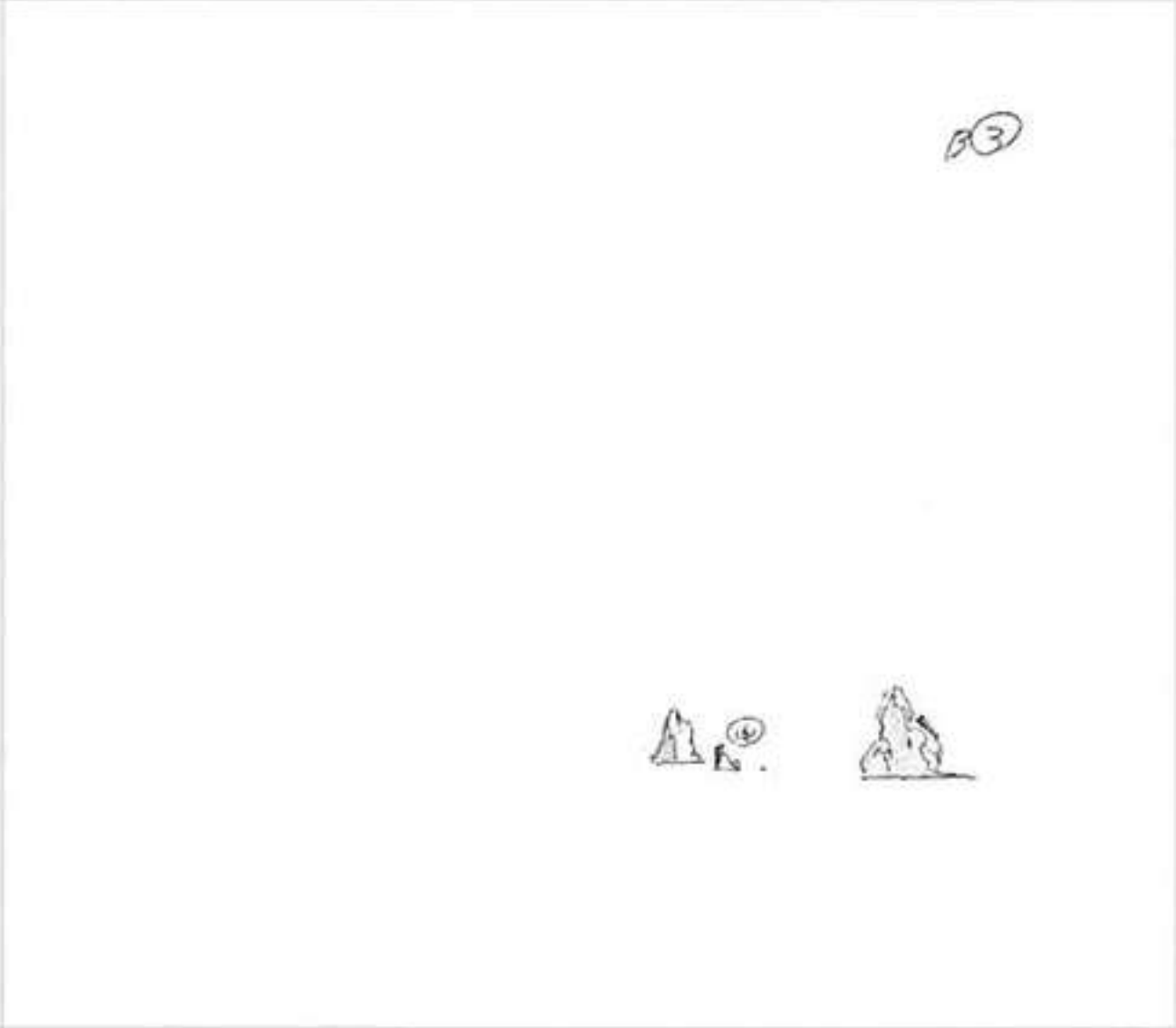
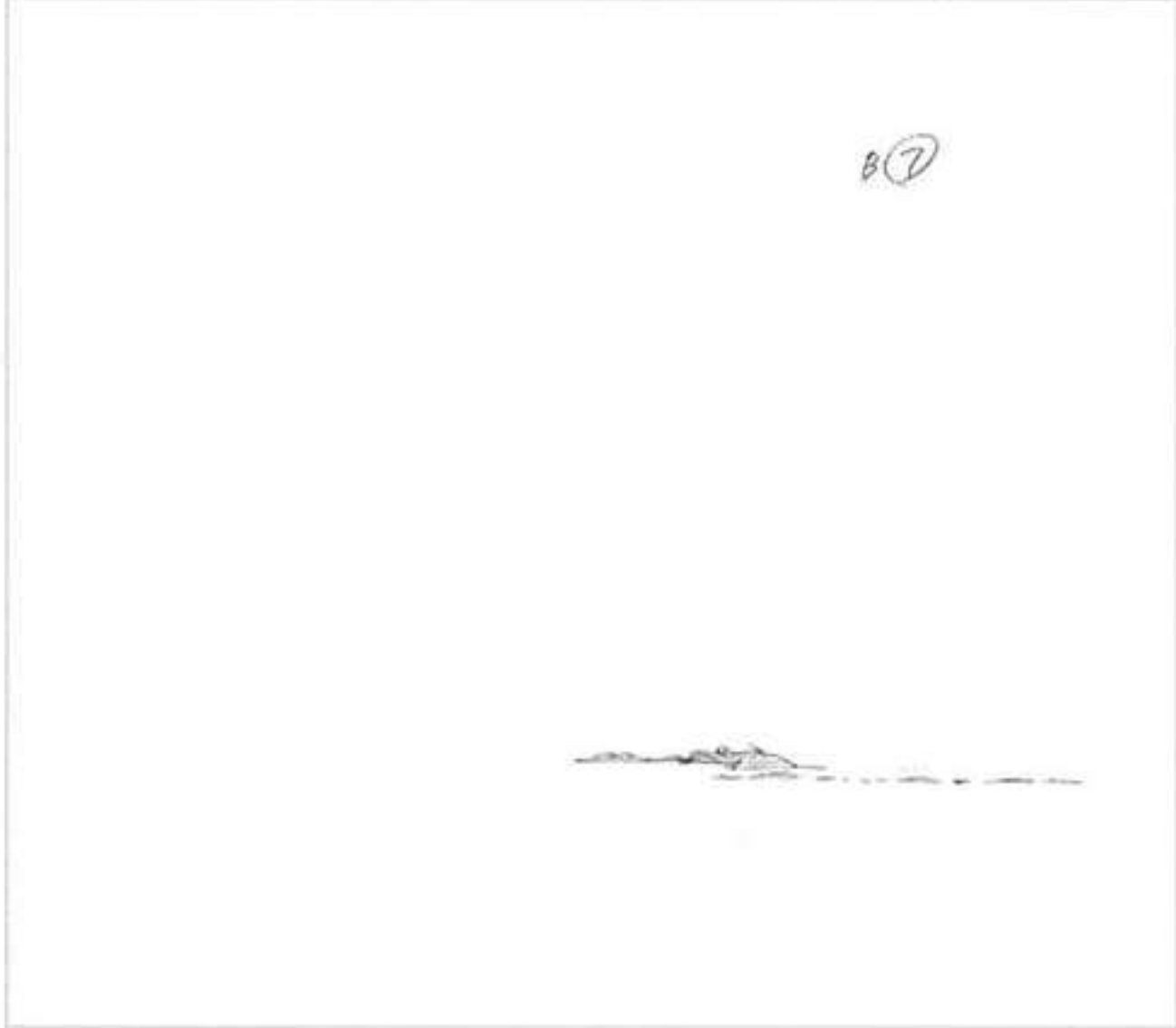
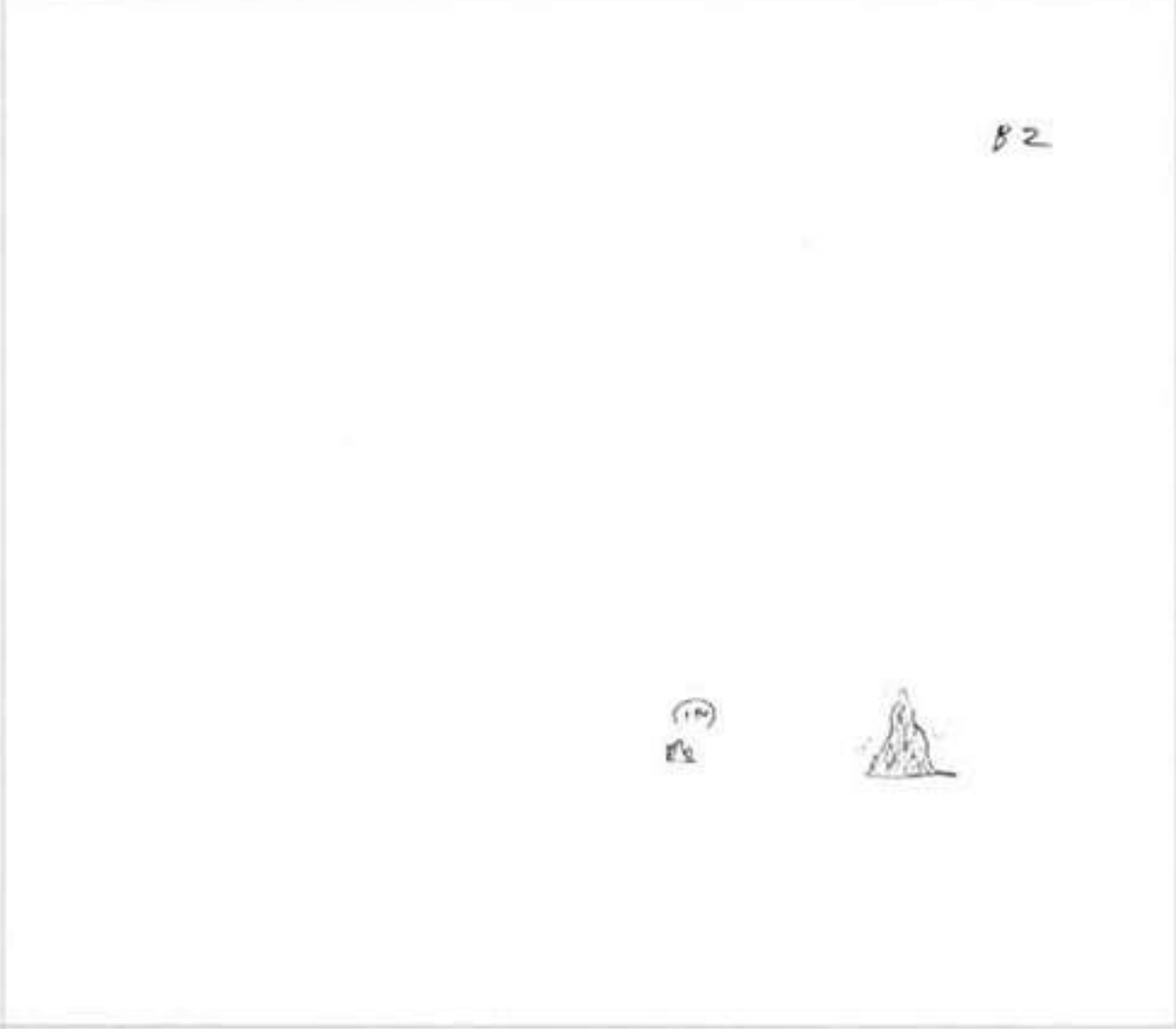
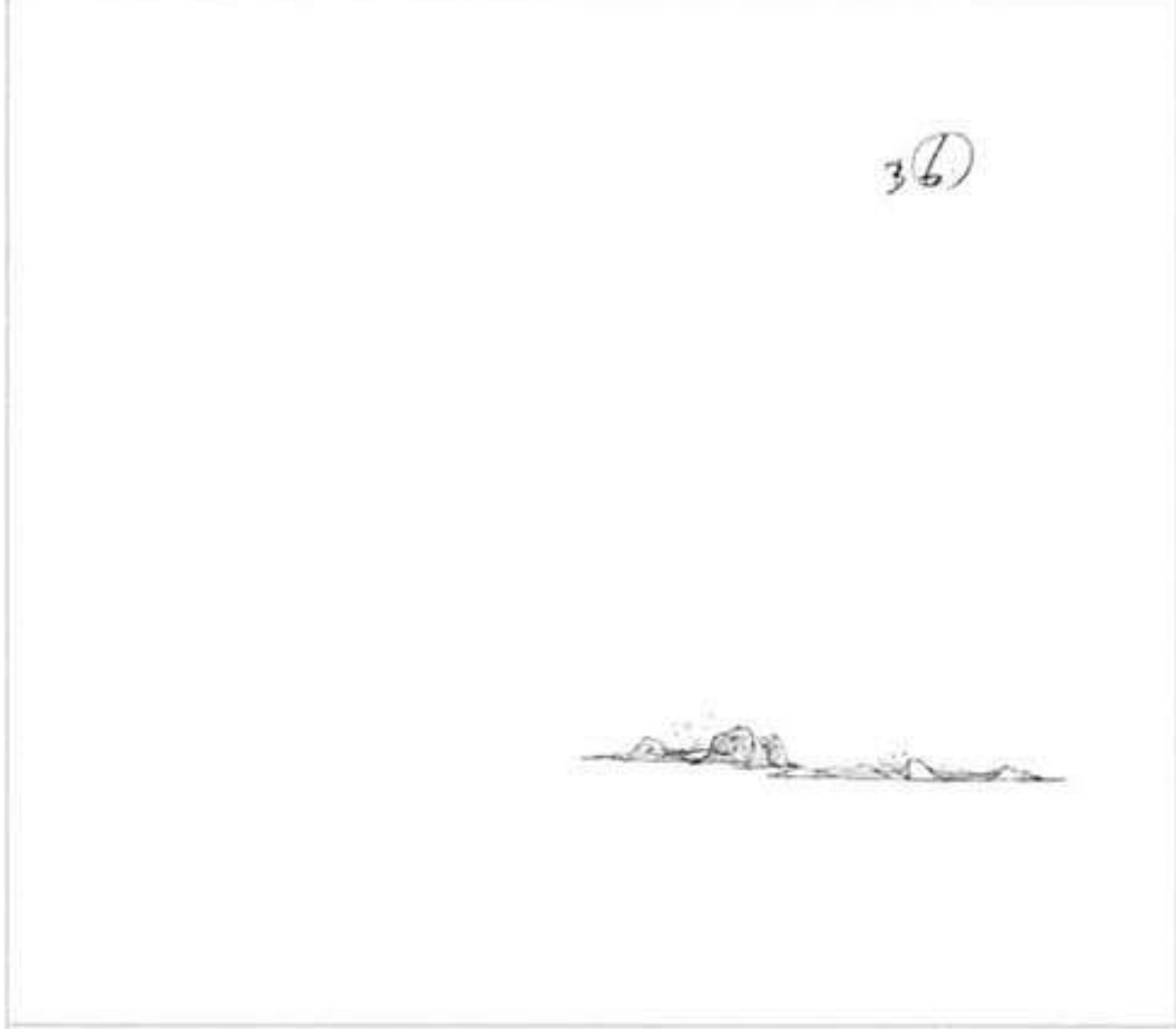
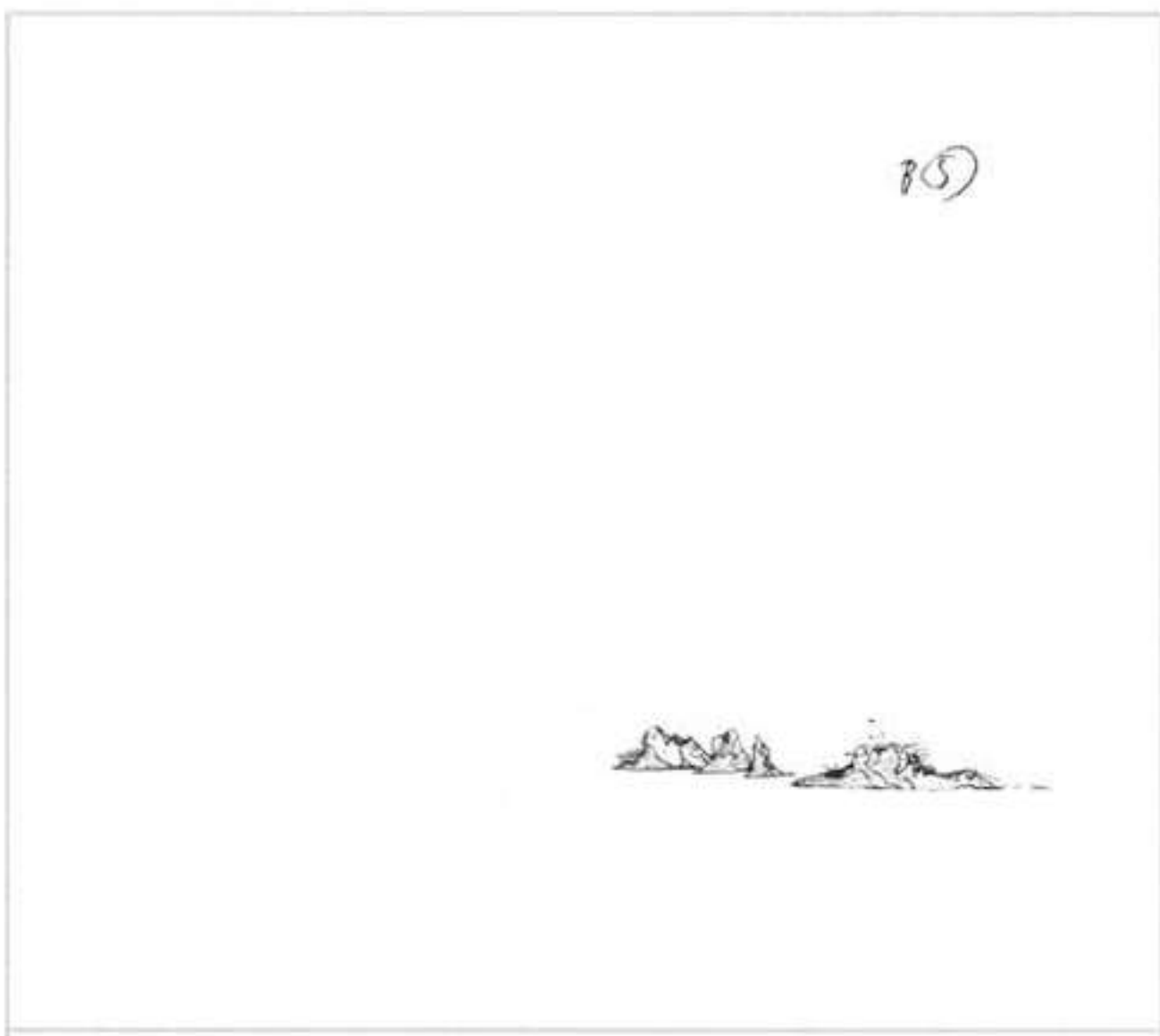

#25-C347





修正原画

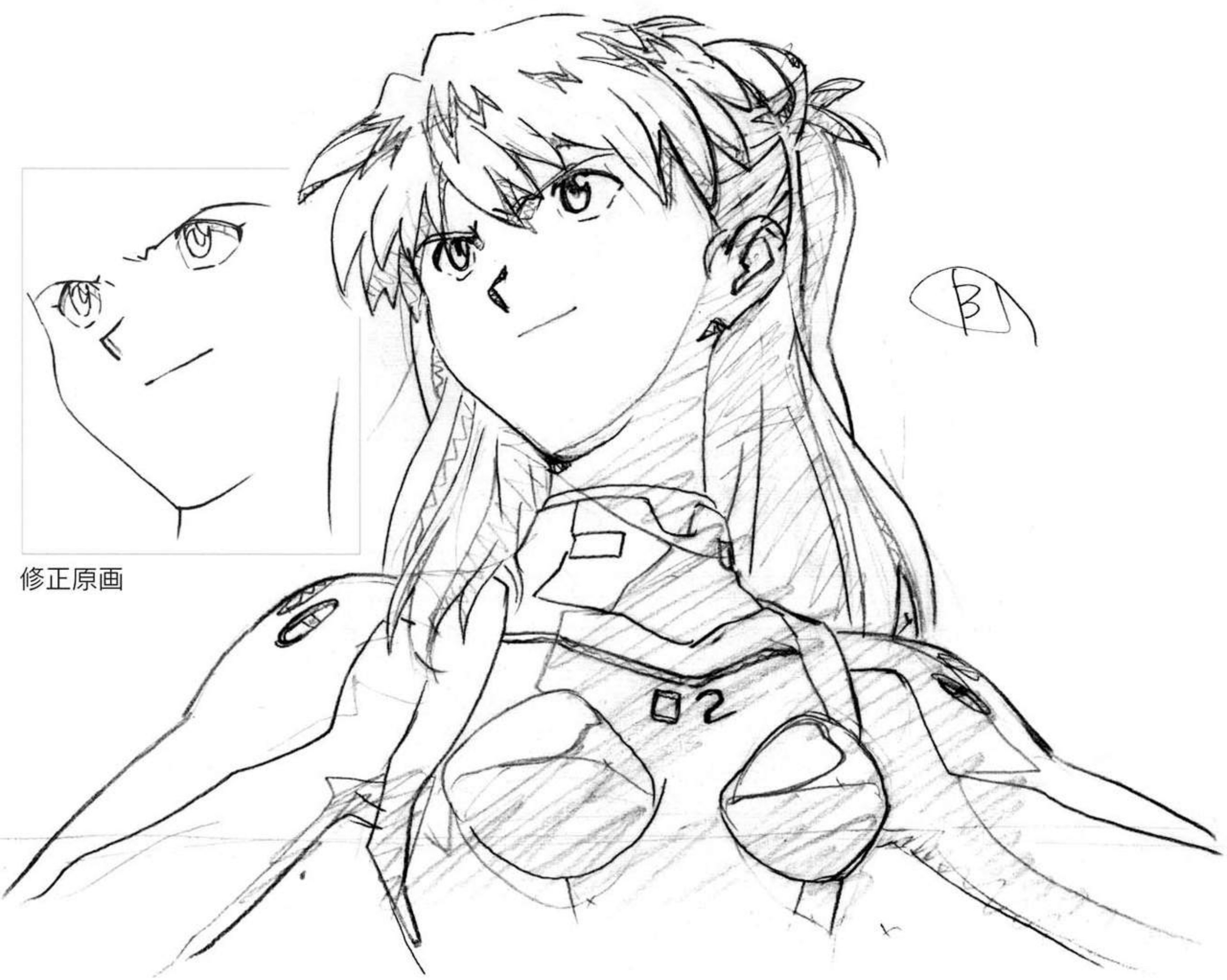

B1

#25-C348

修正原画



B2 91



B2  
© 1998 Animate Studio  
F2 L





A	B	C	D	E	
0	0	0	X	X	2
/	/	/	/	/	4
(2)					6
/	/	/	/	/	8
/	/	/	/	/	10
(1)					12
/	/	/	/	/	14
/	/	/	/	/	16
(2)					18
/	/	/	/	/	20
/	/	/	/	/	22
(1)					24
/	/	/	/	/	26
/	/	/	/	/	28
(2)					30
/	/	/	/	/	32
(1)					34
(2)					36
/	/	/	/	/	38
(1)	(1)	(1)	(1)	(1)	40
(1)	(1)	(1)	(1)	(1)	42
/	/	/	/	/	44
(1)					46
X					48
/	/	/	/	/	50
/	/	/	/	/	52
/	/	/	/	/	54
(1)					56
X					58
/	/	/	/	/	60
/	/	/	/	/	62
/	/	/	/	/	64
/	/	/	/	/	66
(2)					68
/	/	/	/	/	70
/	/	/	/	/	72

B		
/		74
/		76
(3)		78
/		80
/		82
/		84
/		86
/		88
/		90
/		92
/		94
/		96

タイムシート

修正原画

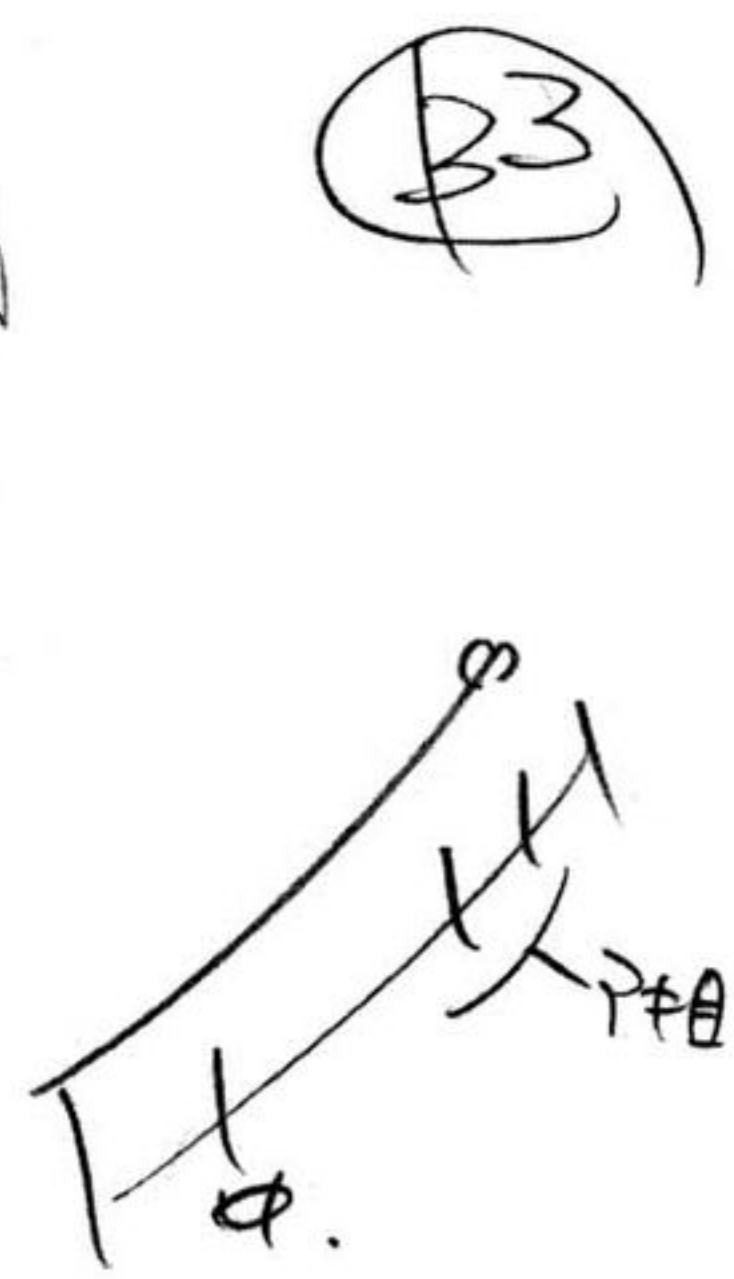
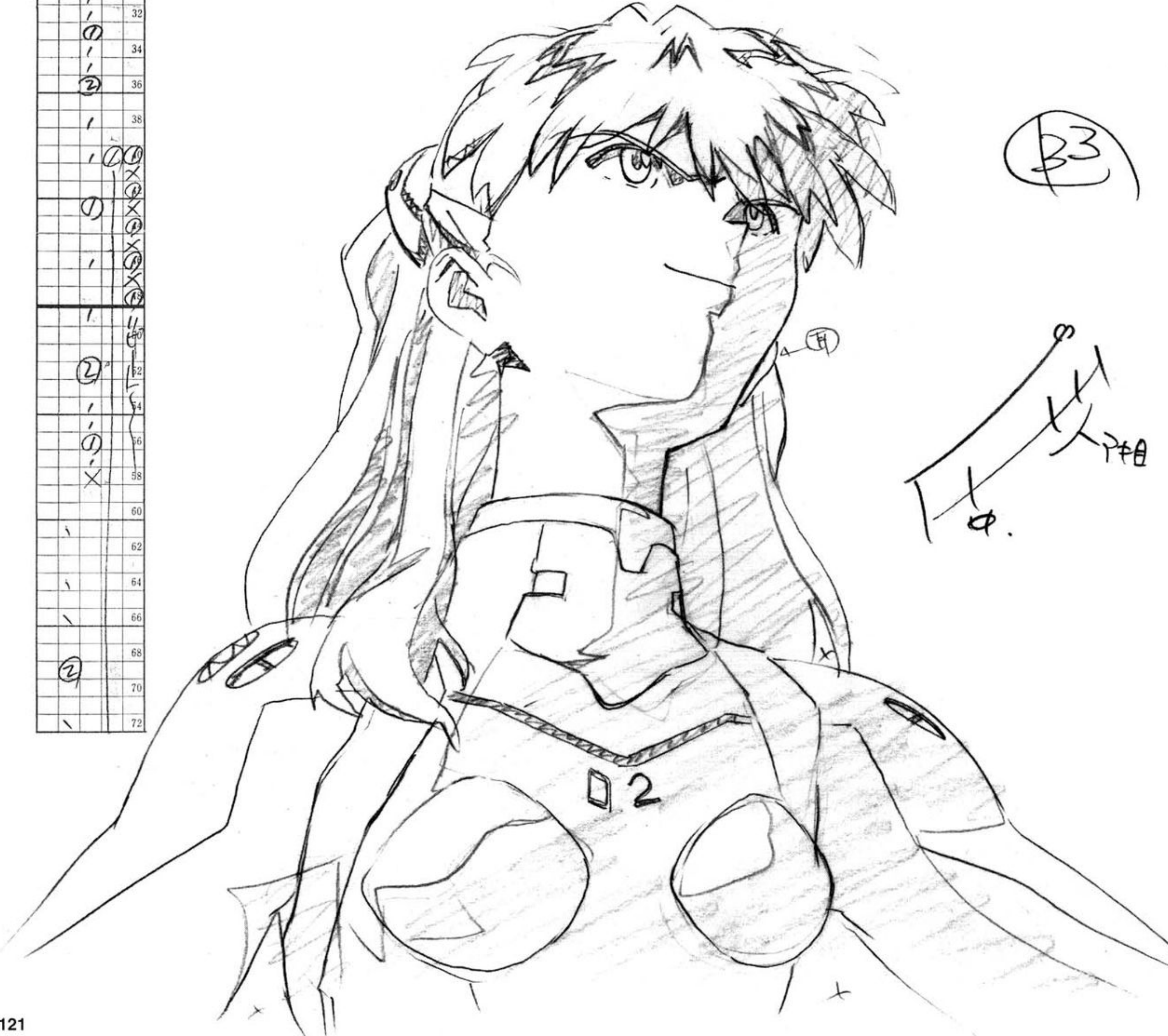





#25-C350





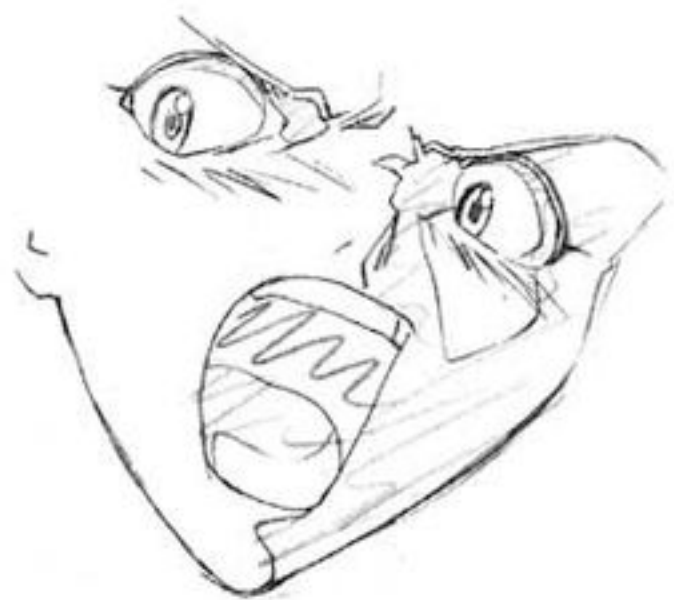

B-5  
73

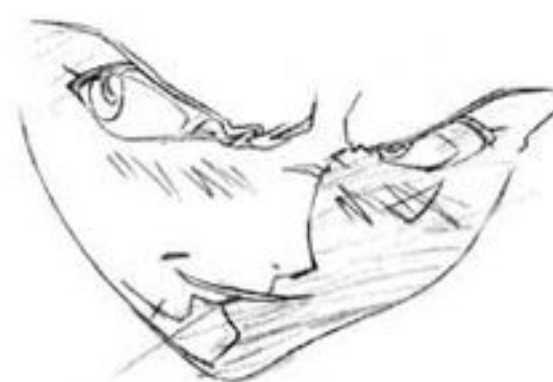

B49B



02

B-6  
73



(B5)

02

タイムシート

AB	
1	2
2	4
3	6
4	8
5	10
6	12
7	14
8	16
9	18
10	20
11	22
12	24
13	26
14	28
15	30
16	32
17	34
18	36
19	38
20	40
21	42
22	44
23	46
24	48



(B6)

6





#25-C352

修正原画





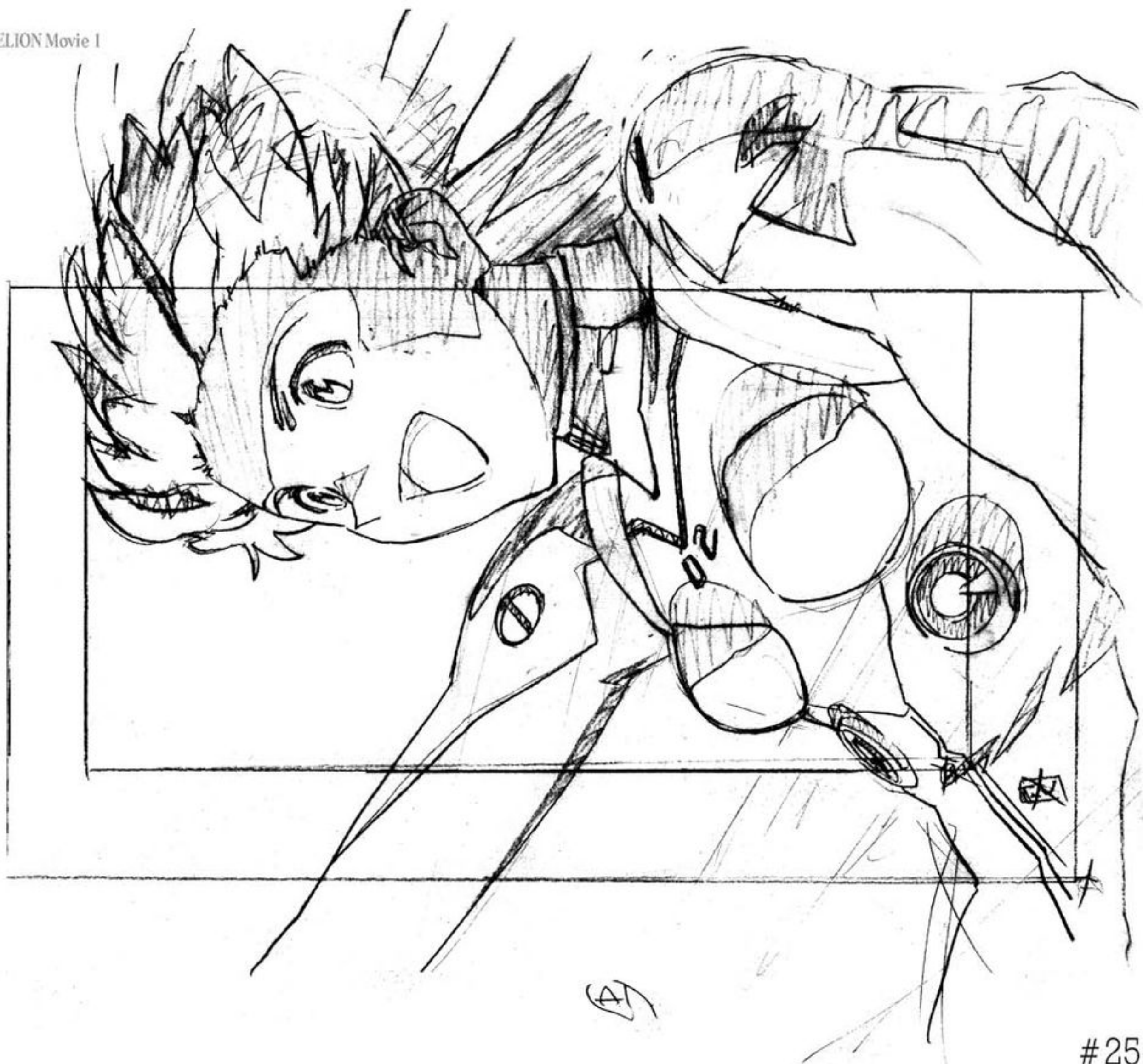

#25-C354

修正原画





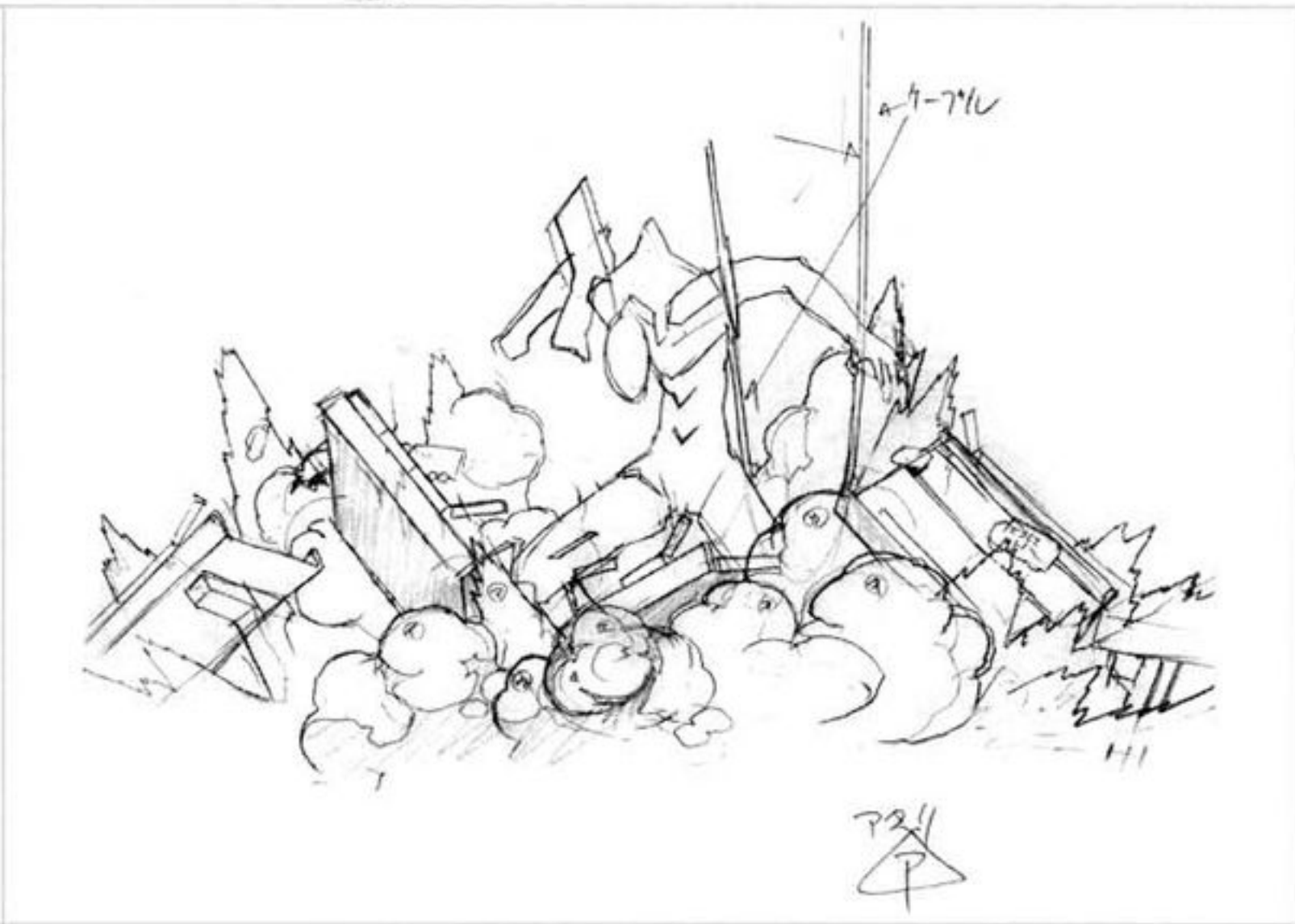
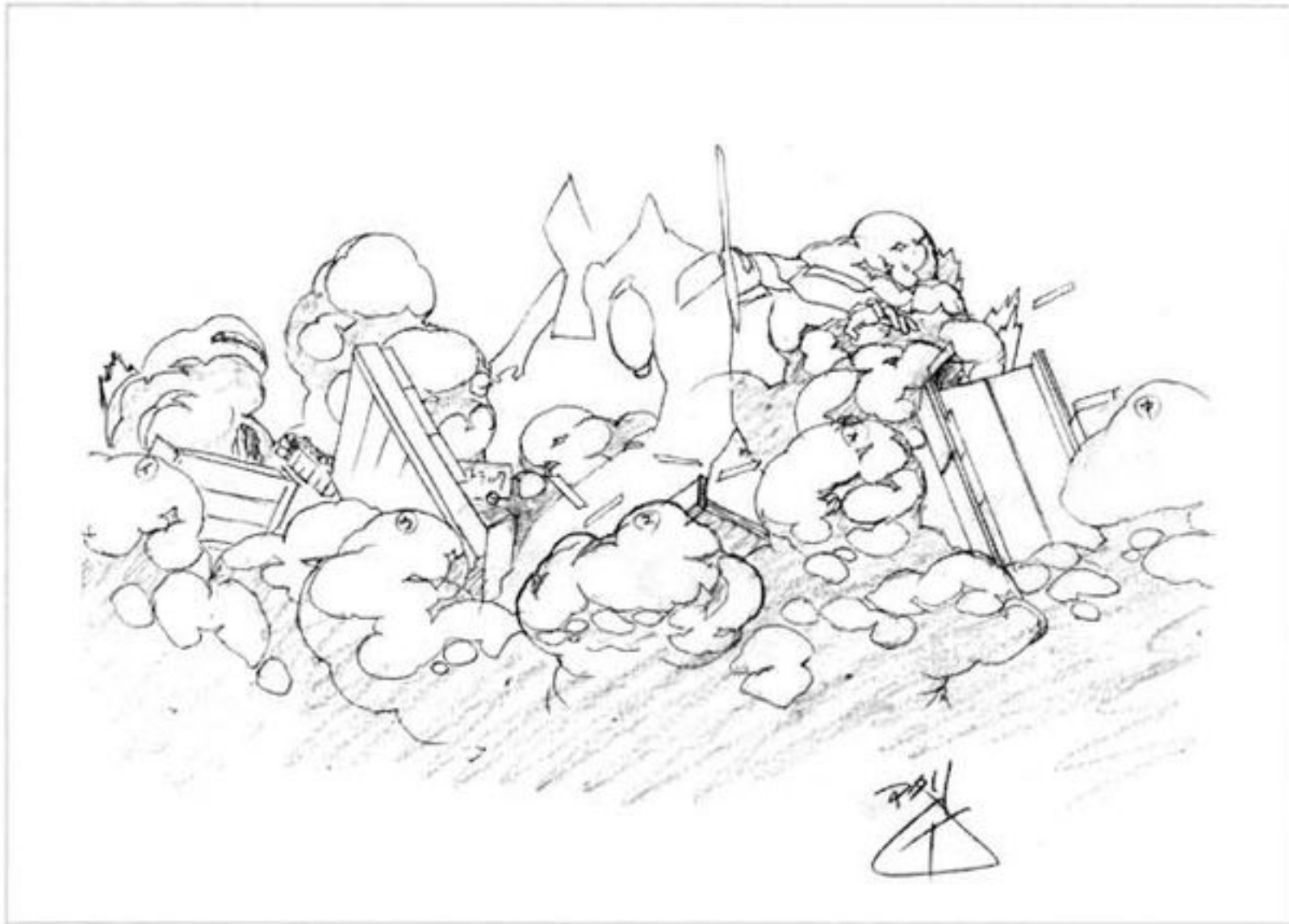
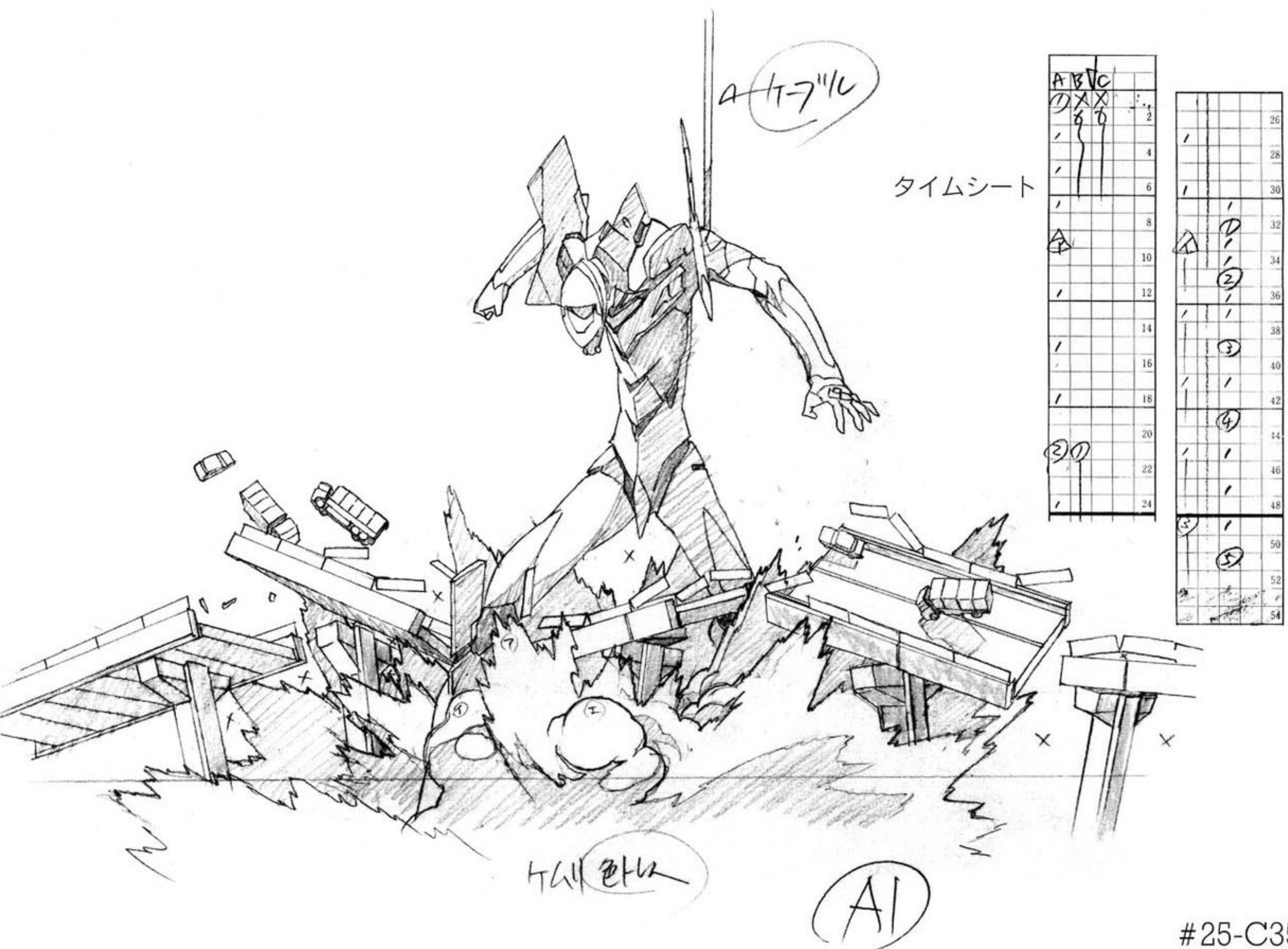



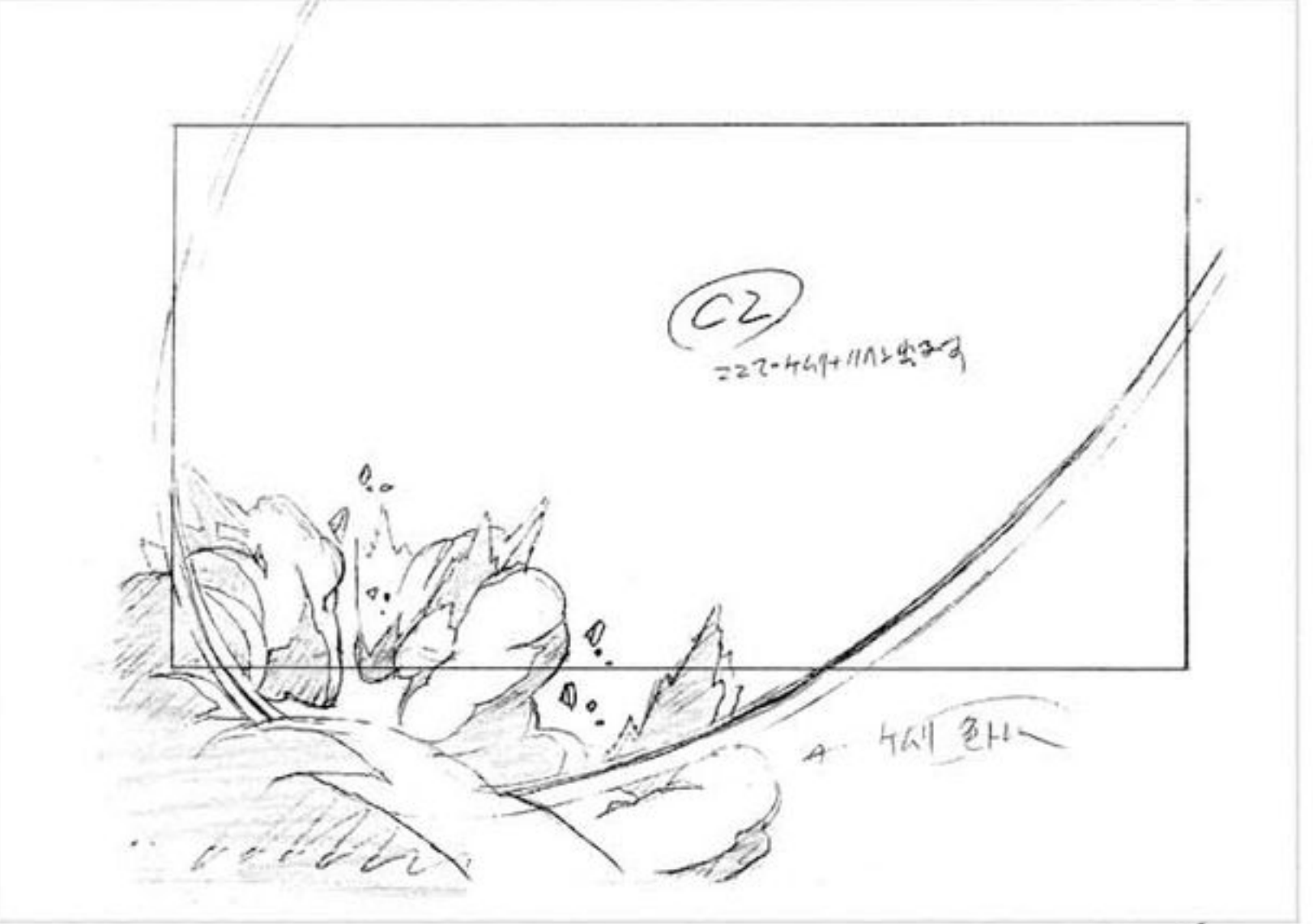
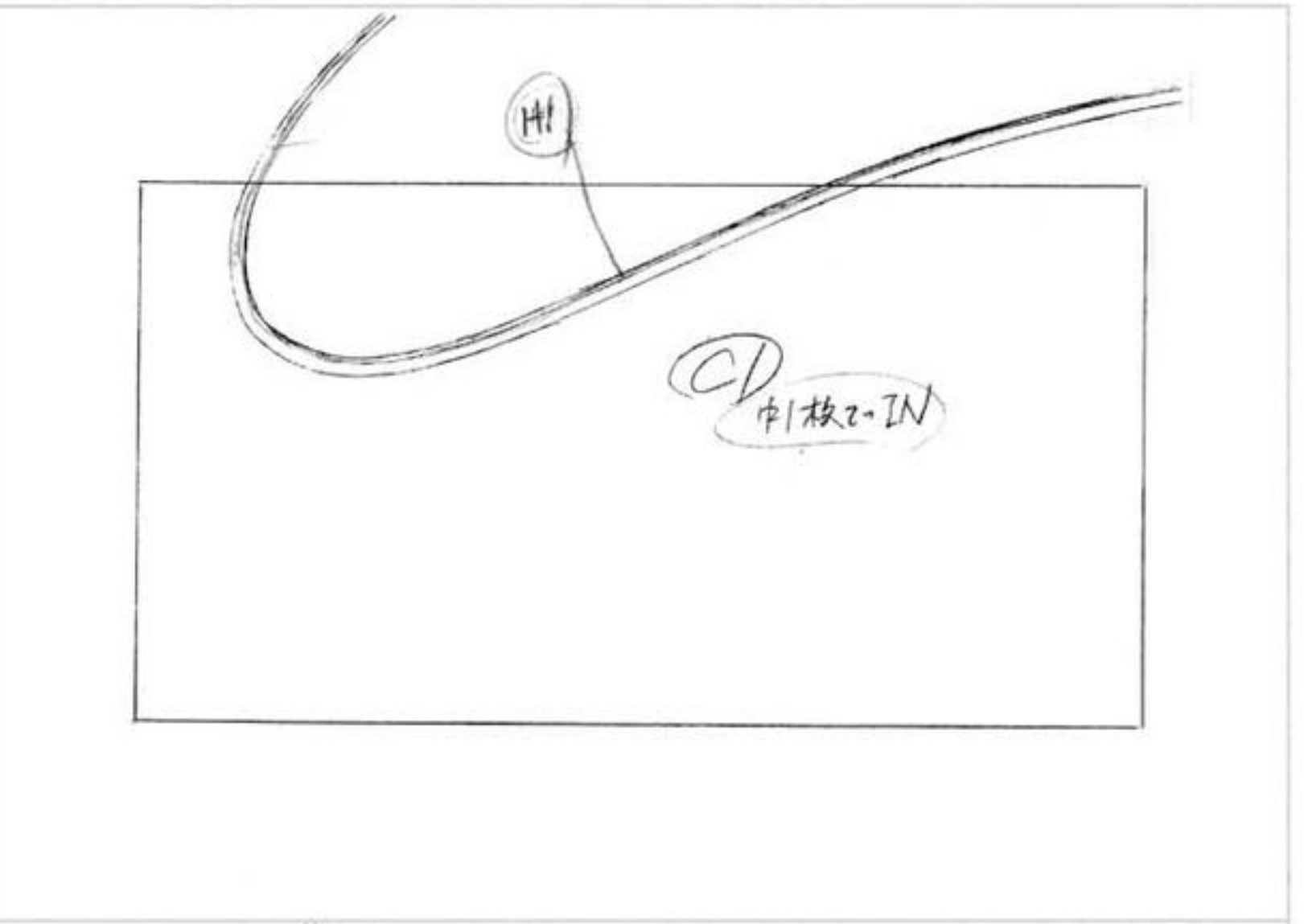
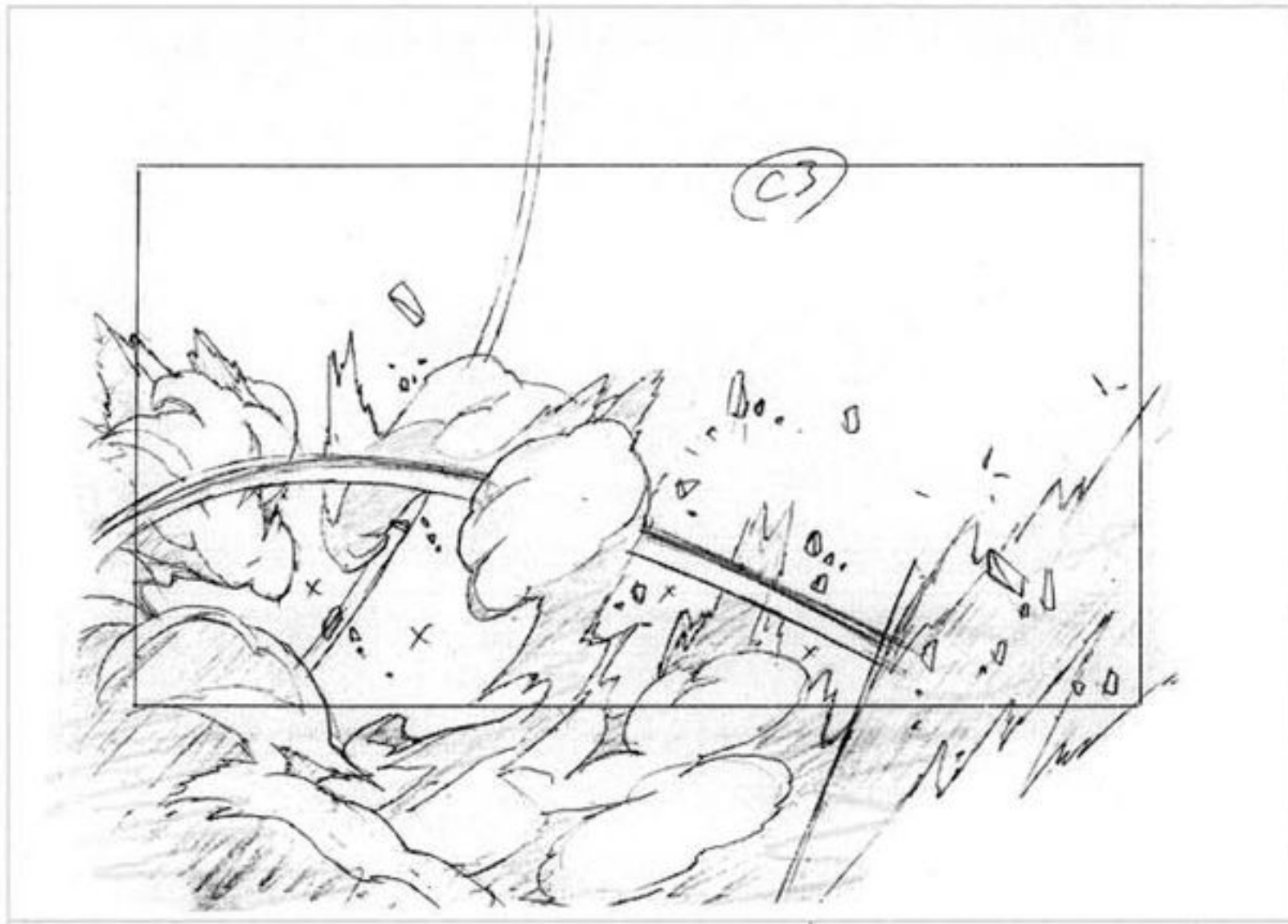

#25-C356

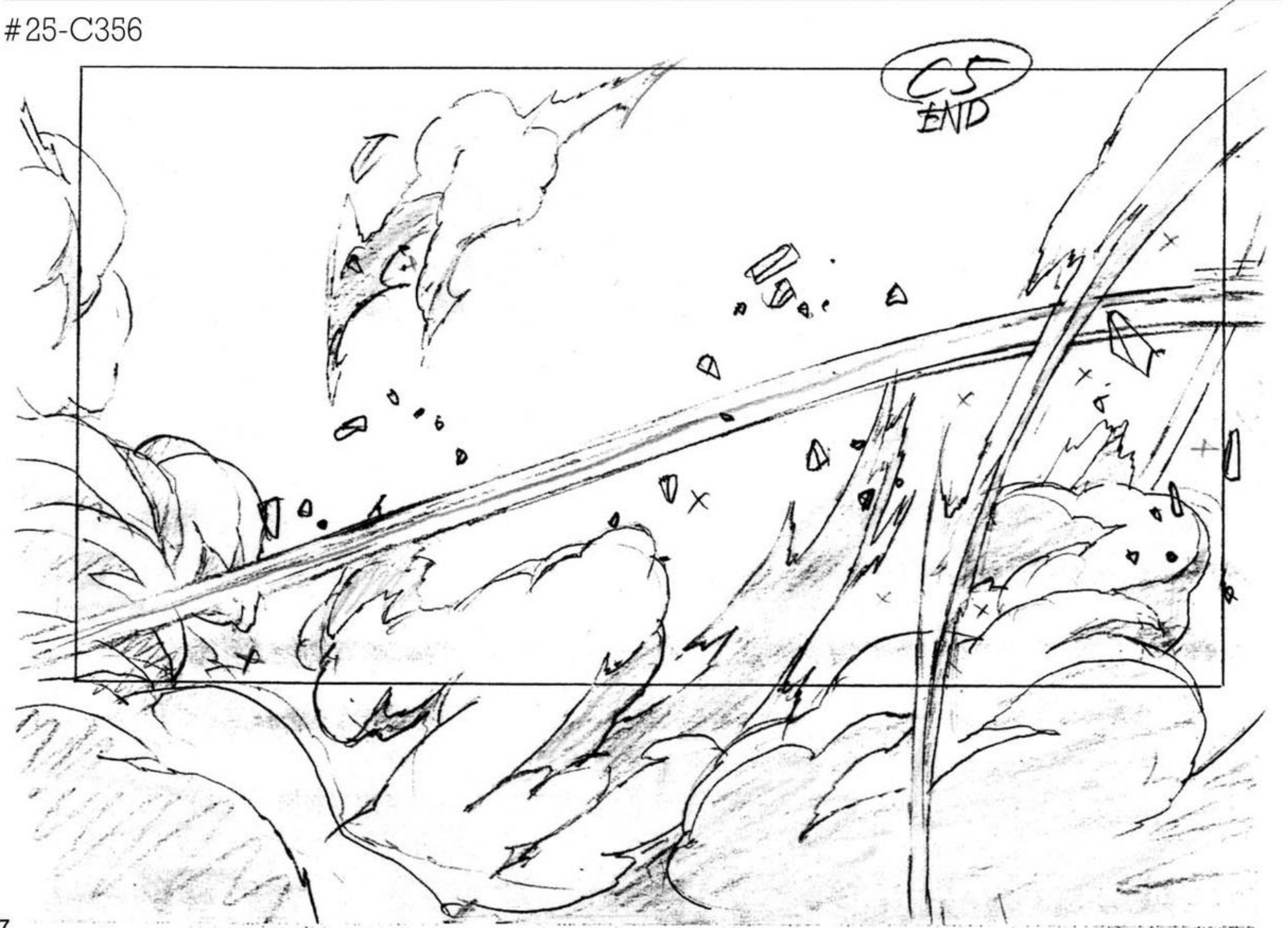



#25-C358

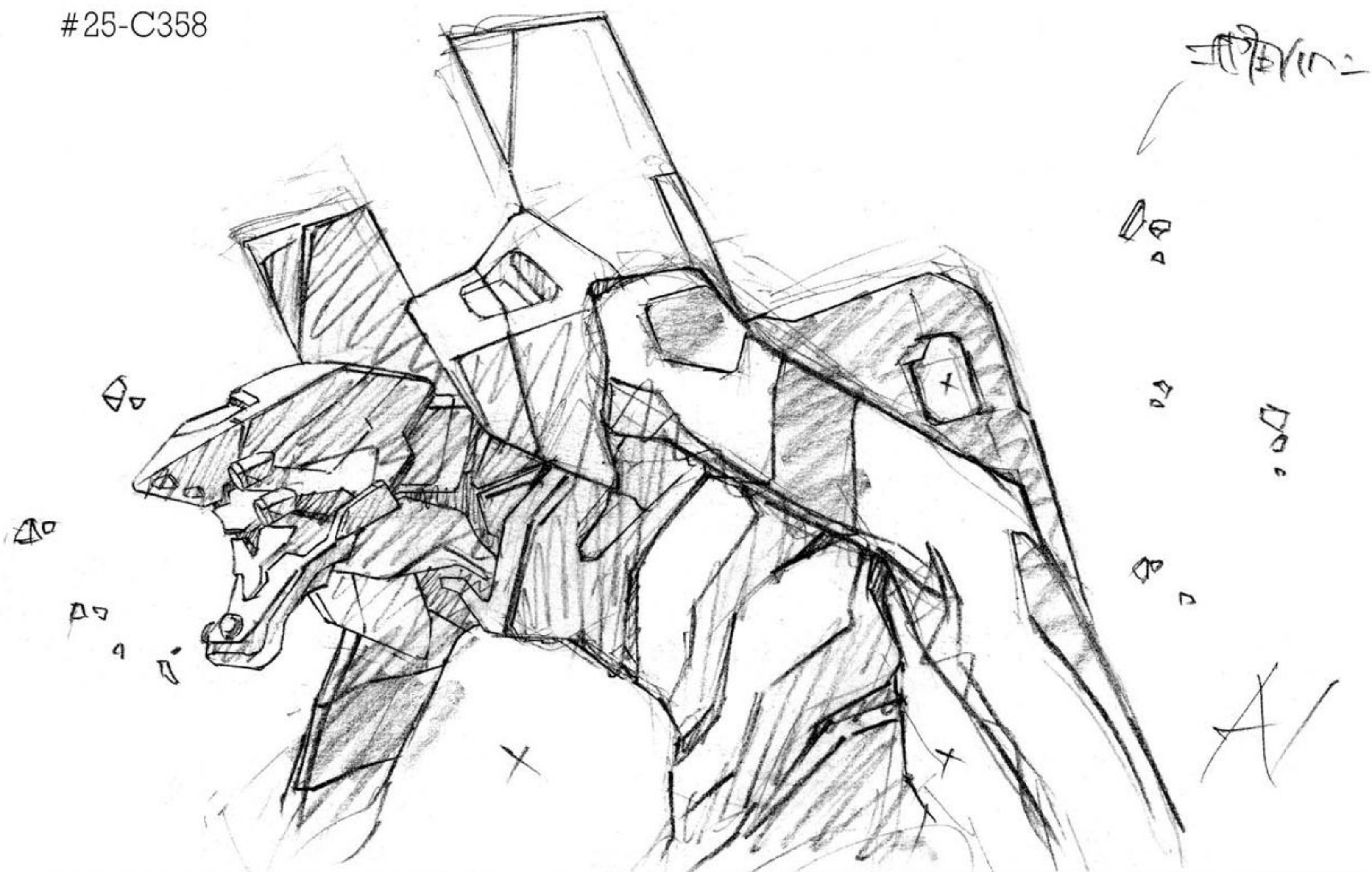

修正原画

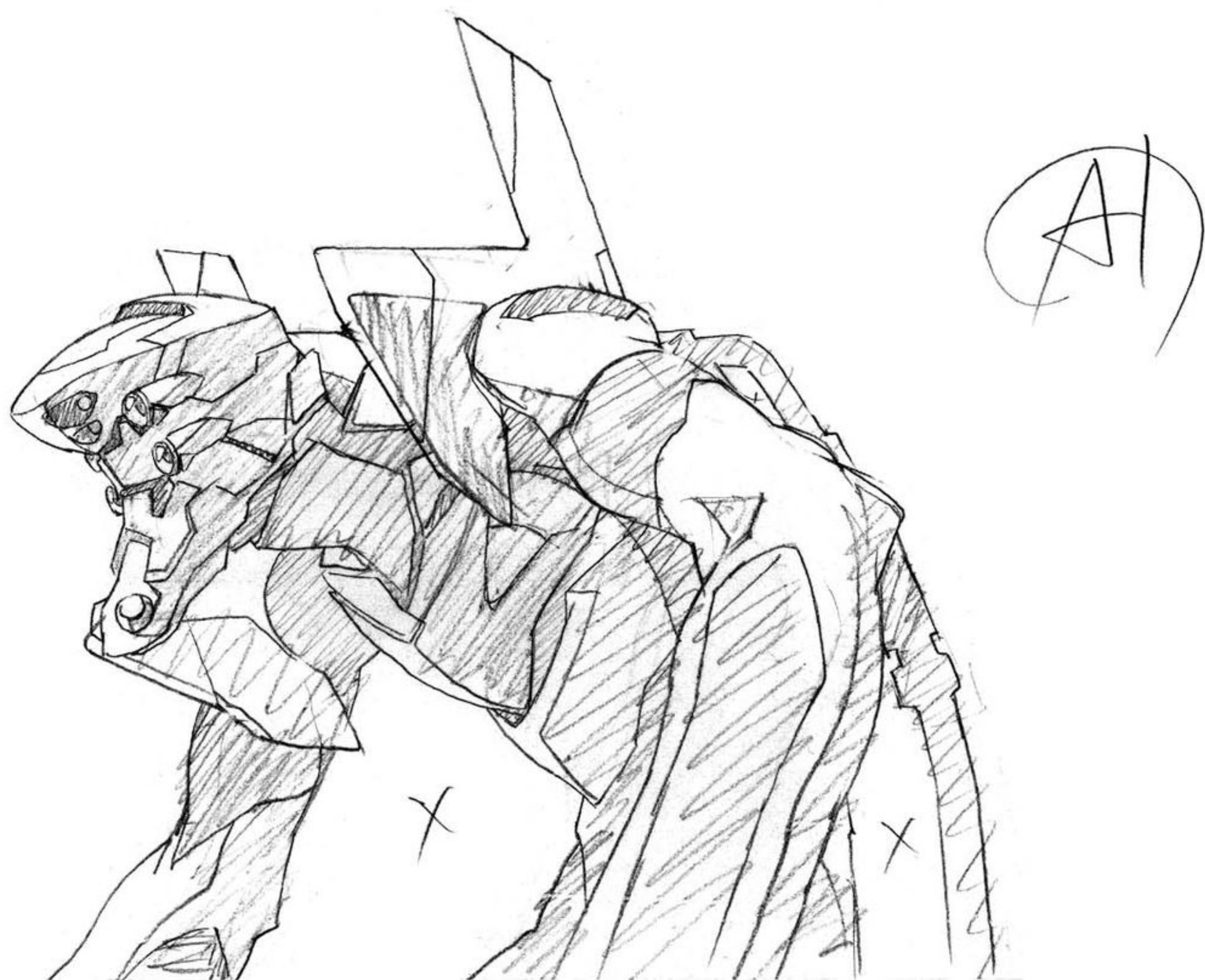



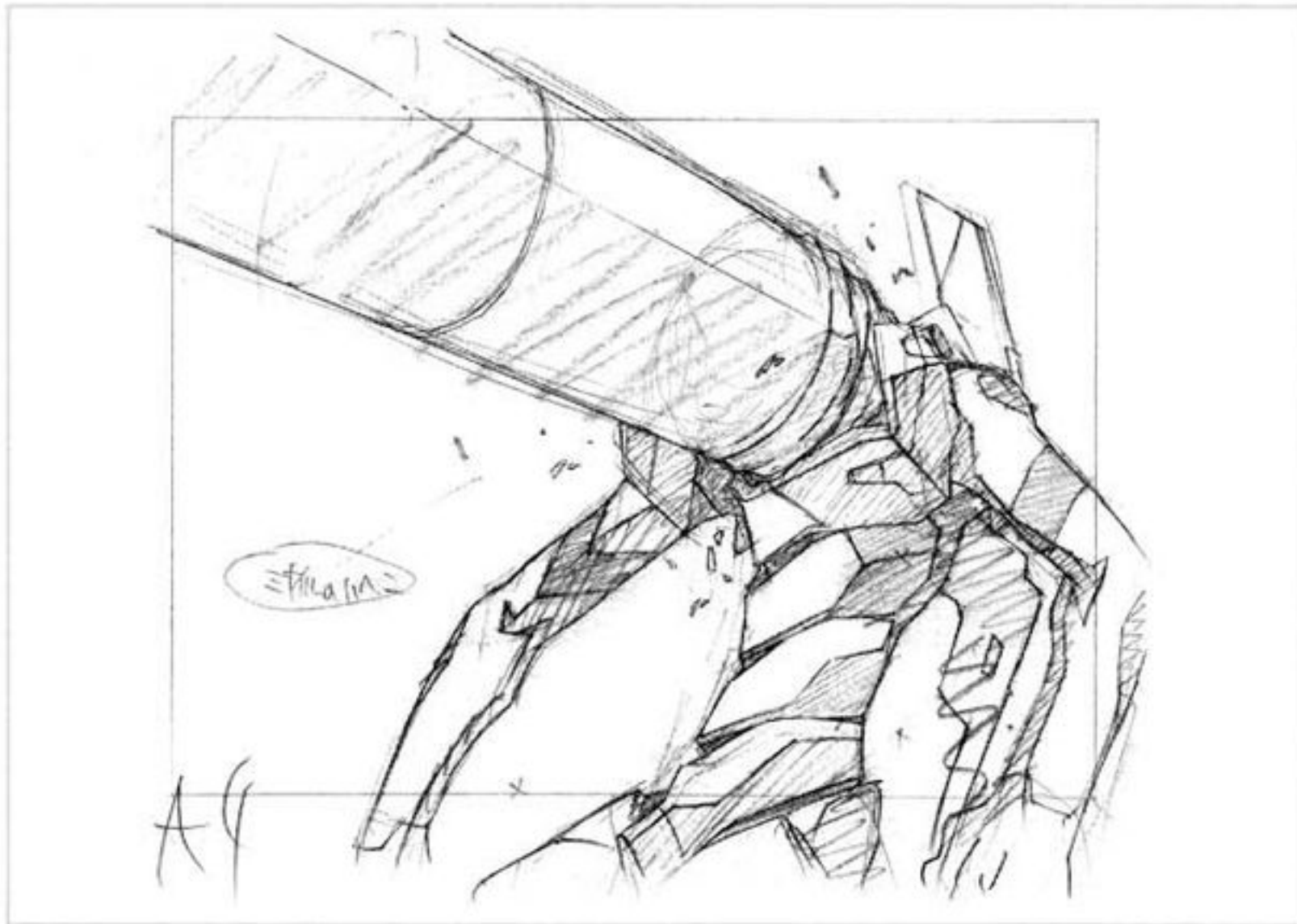

修正原画

修正原画



修正原画

修正原画

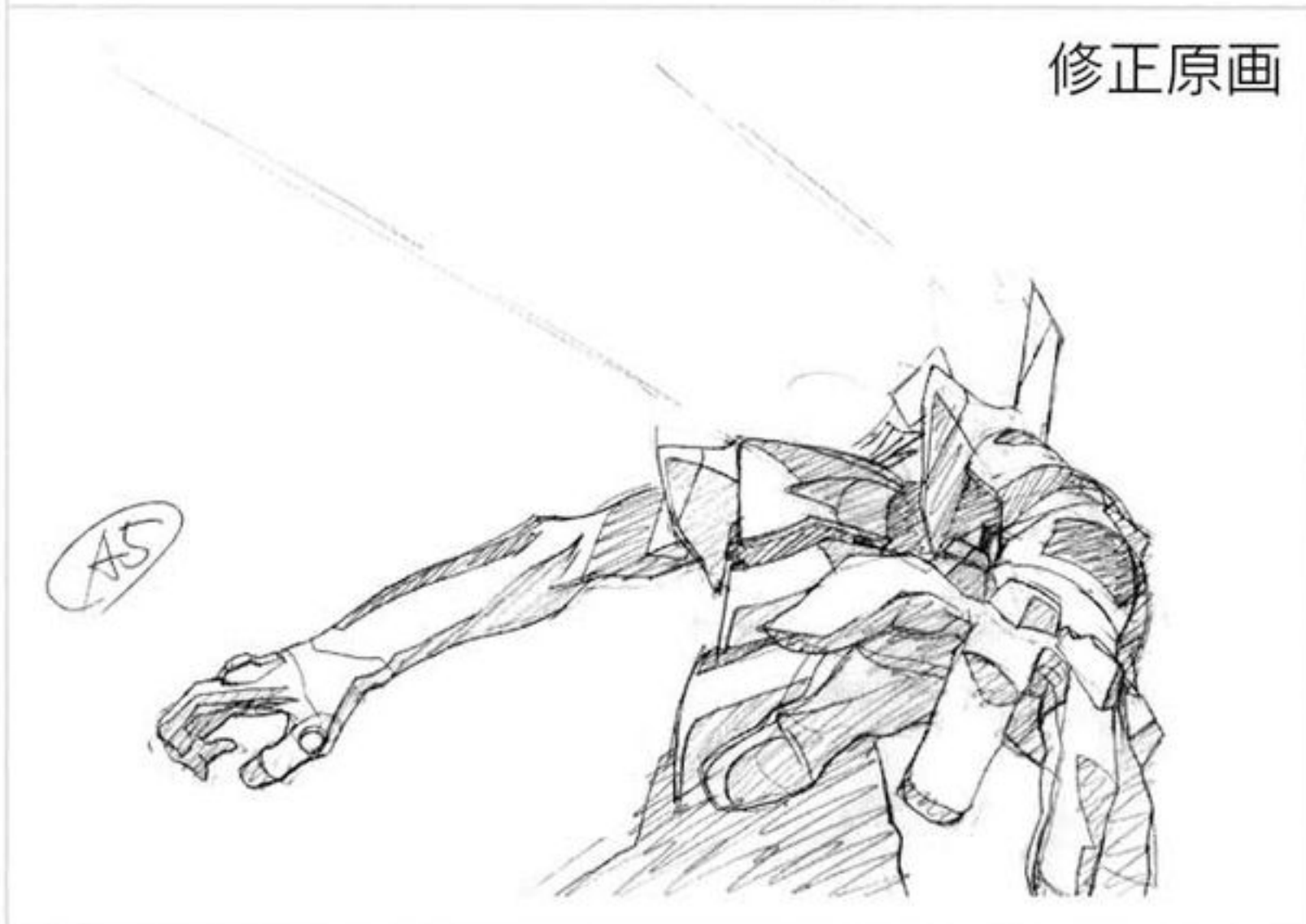



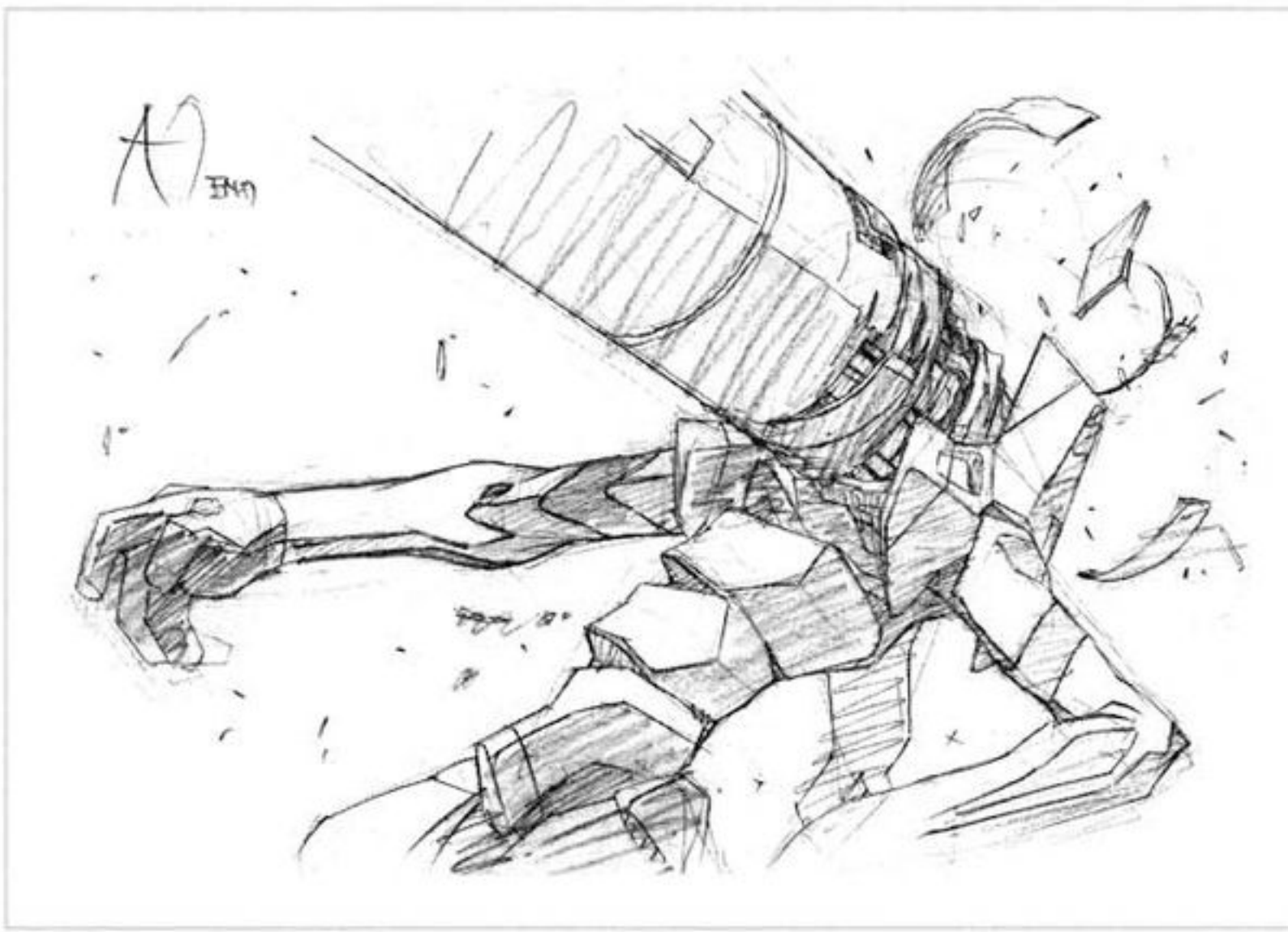

△BC	
1	
2	
3	
4	
5	
6	
7	
8	
9	
10	
11	
12	①XX
13	
14	
15	
16	
17	
18	
19	
20	②
21	
22	
23	
24	
25	
26	
27	
28	
29	
30	

32	
33	
34	③①
35	②
36	④X①
37	
38	⑤
39	
40	
41	
42	
43	
44	
45	
46	
47	
48	
49	
50	
51	
52	
53	
54	
55	
56	
57	
58	
59	
60	
61	

タイムシート

修正原画



#25-C358

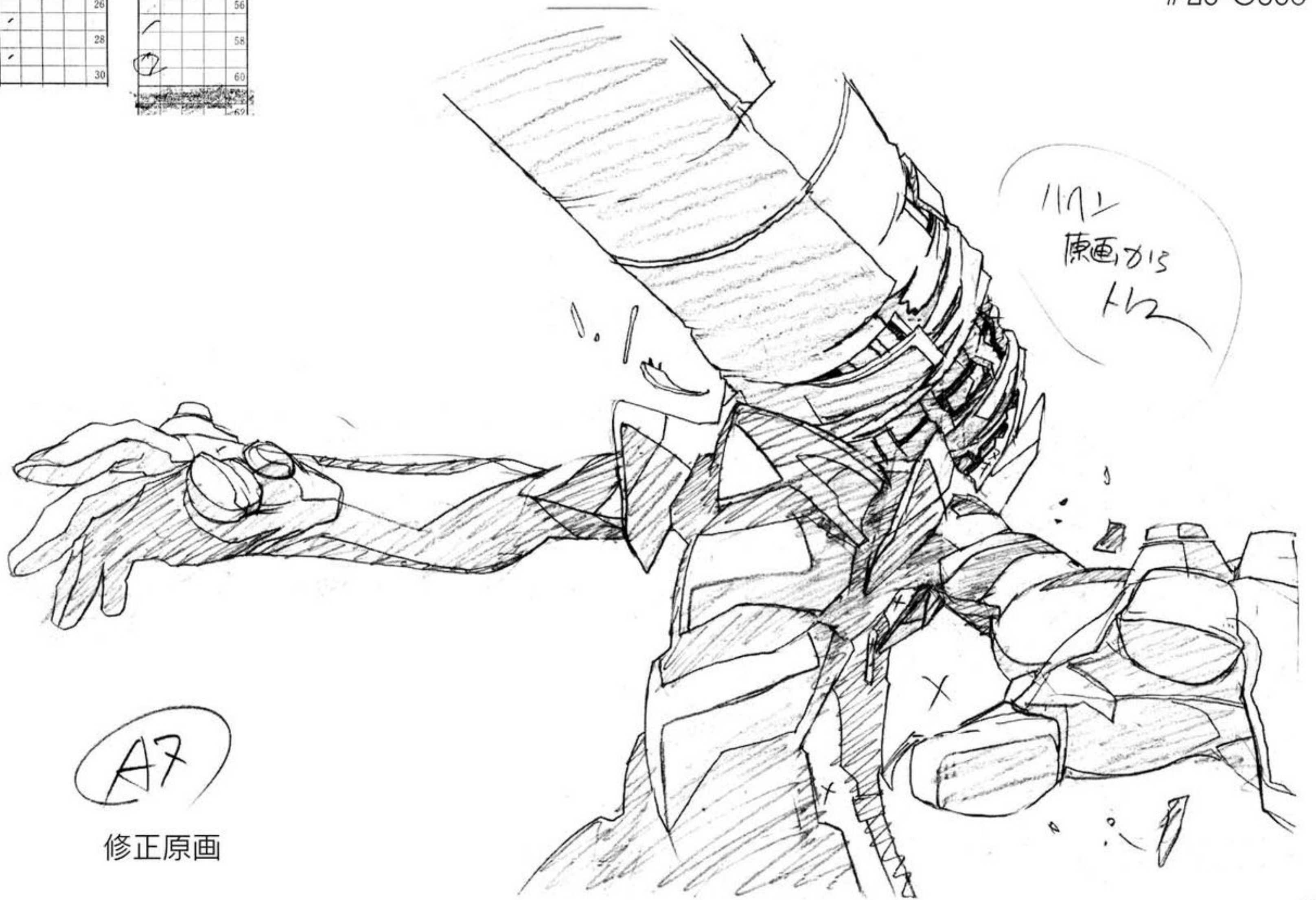



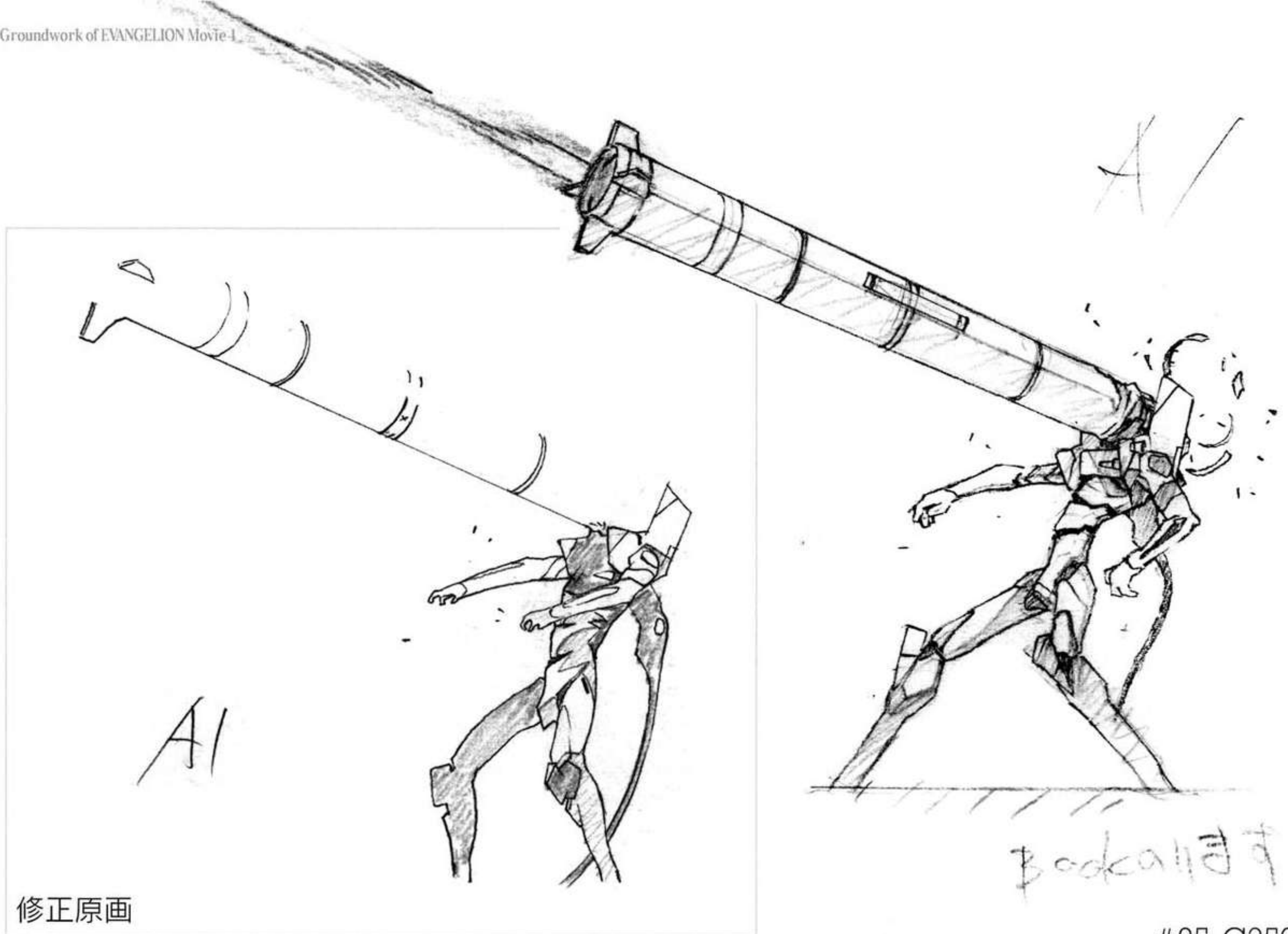

修正原画

#25-C359

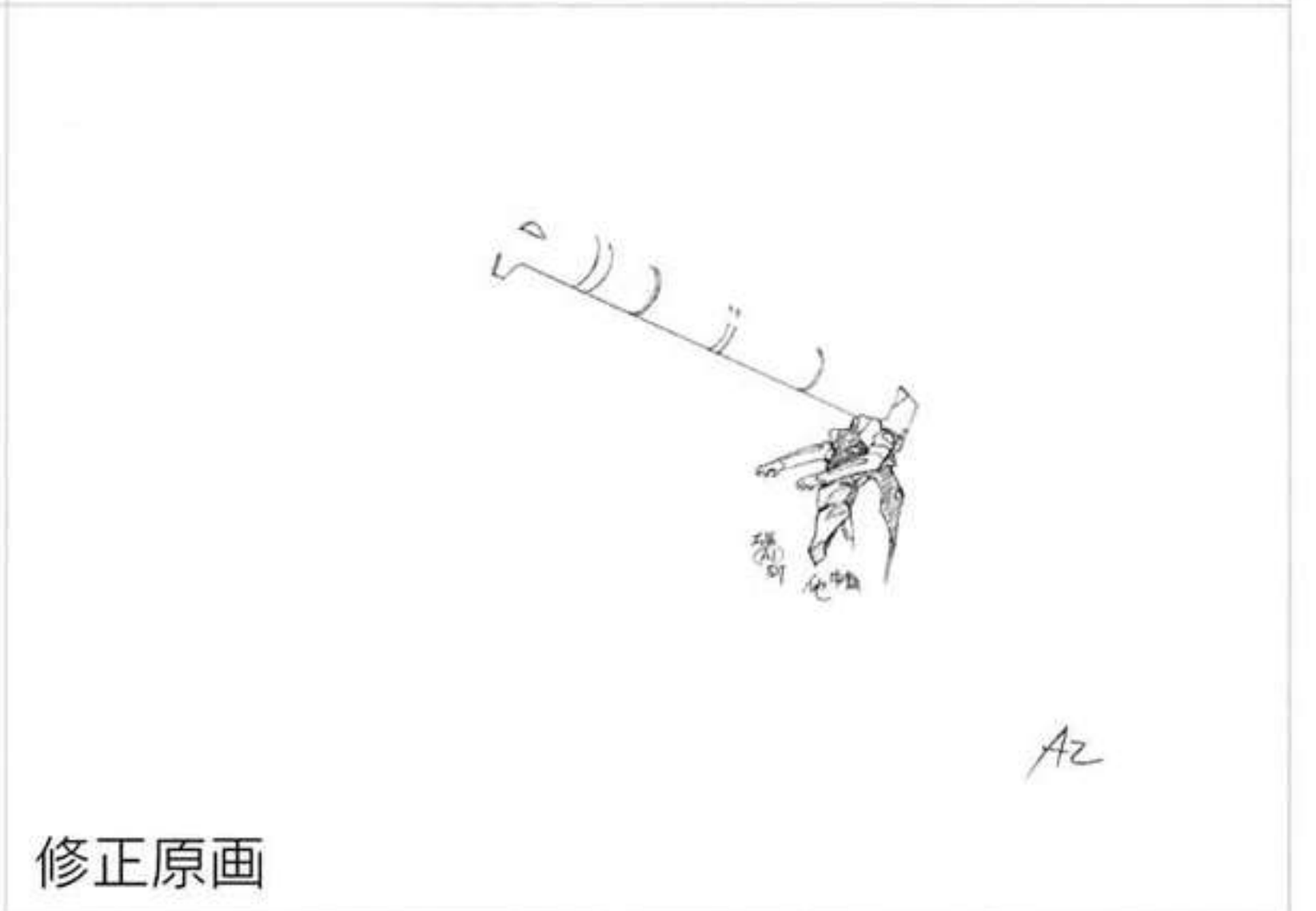
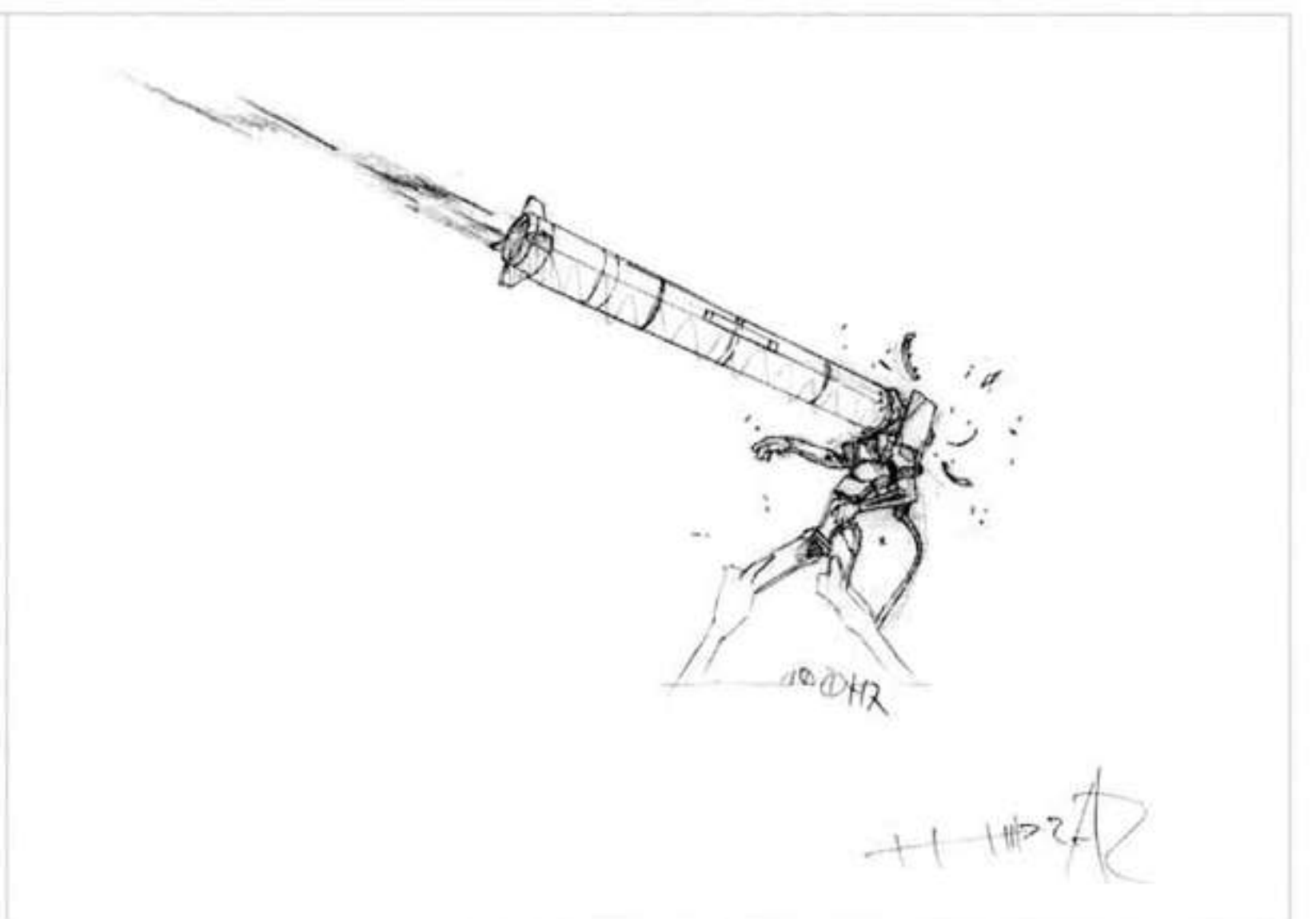
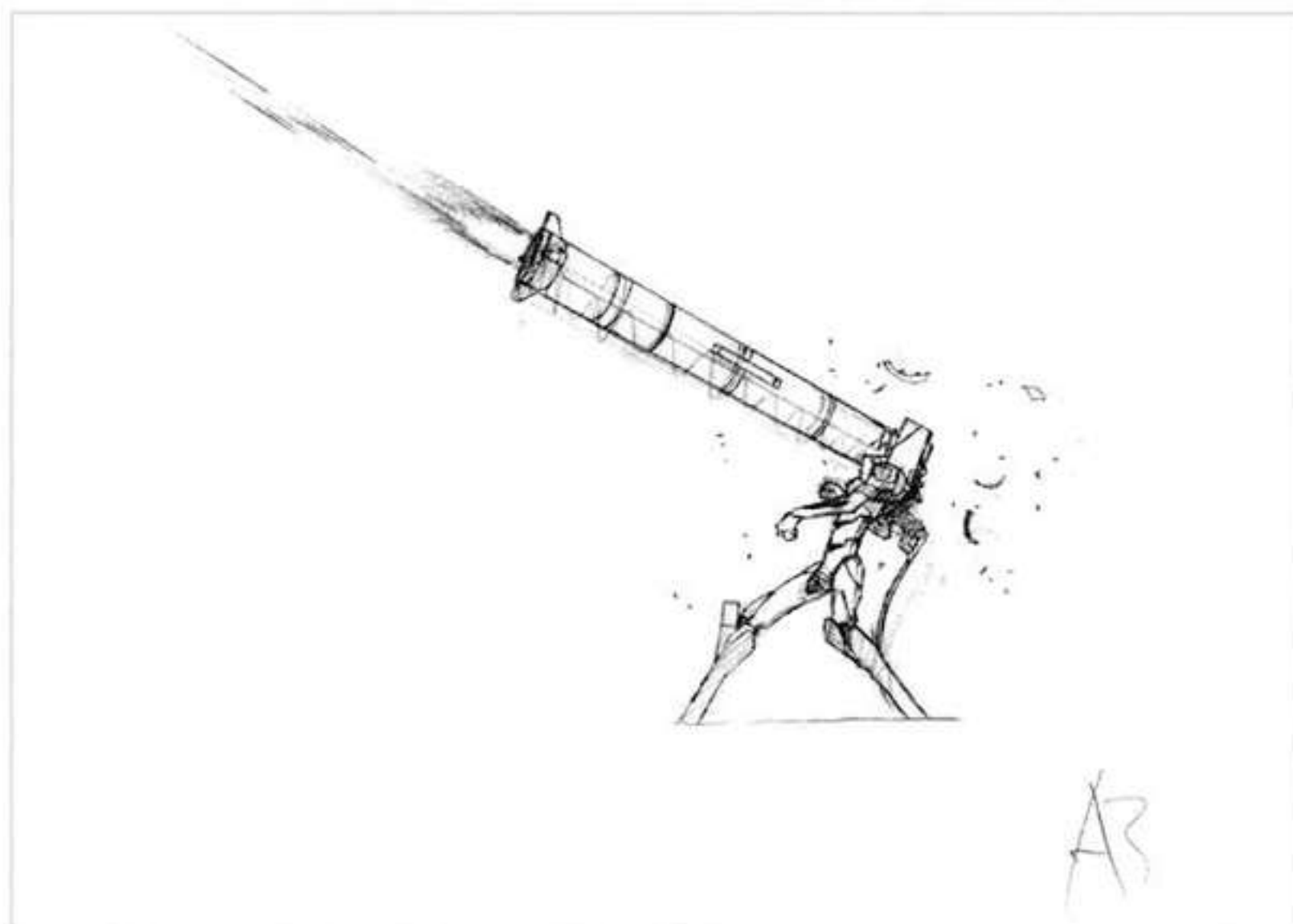

修正原画

修正原画



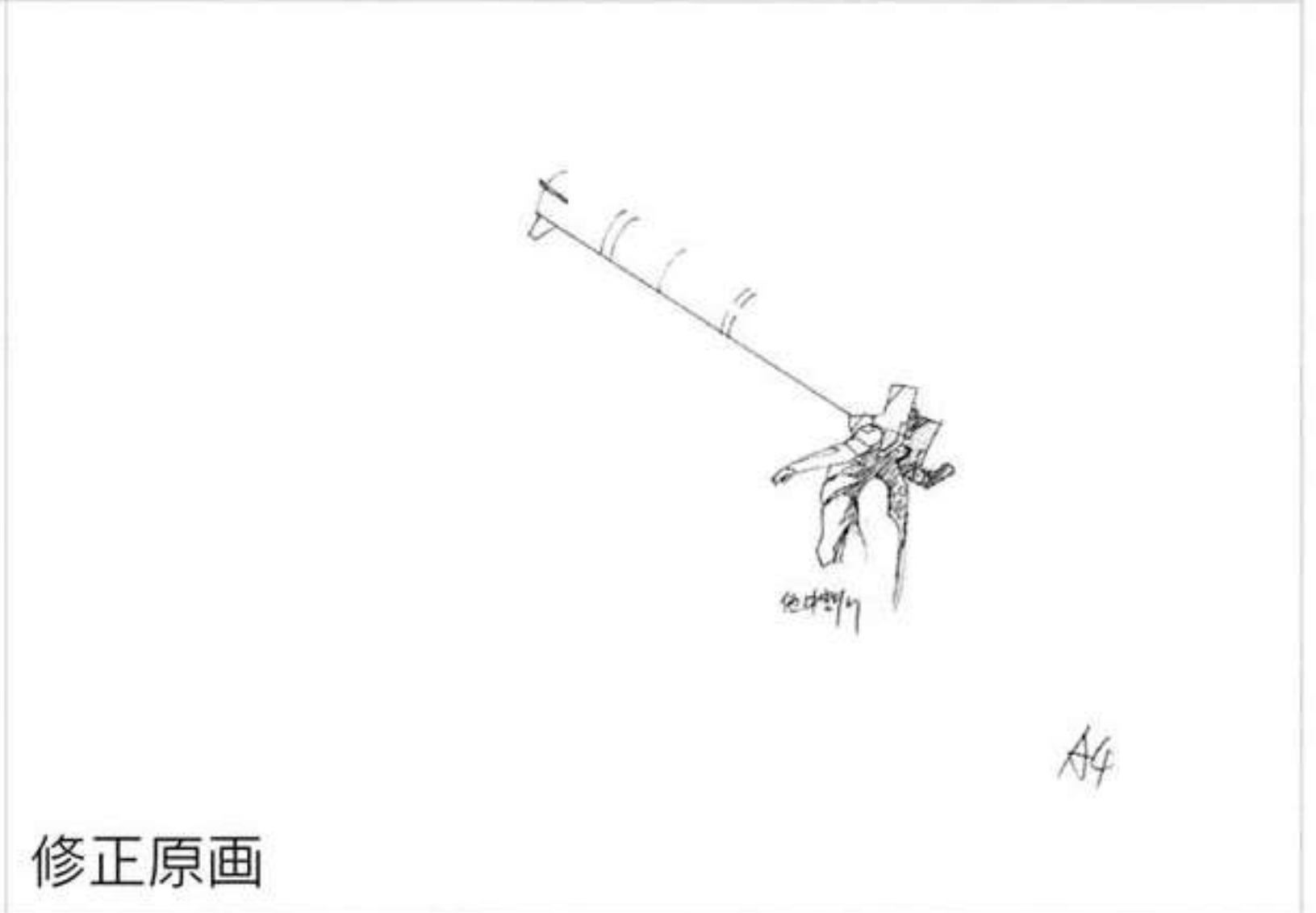
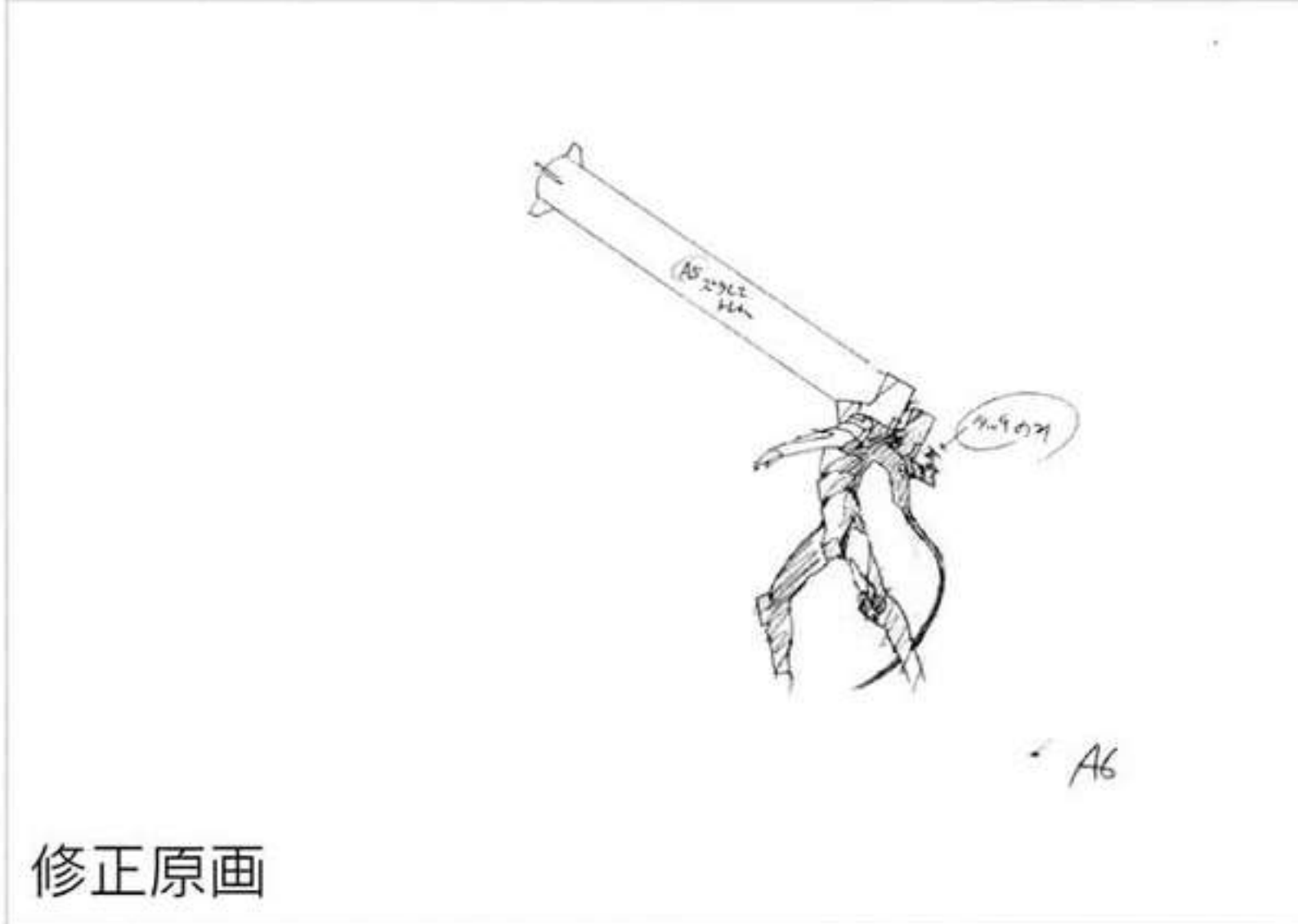
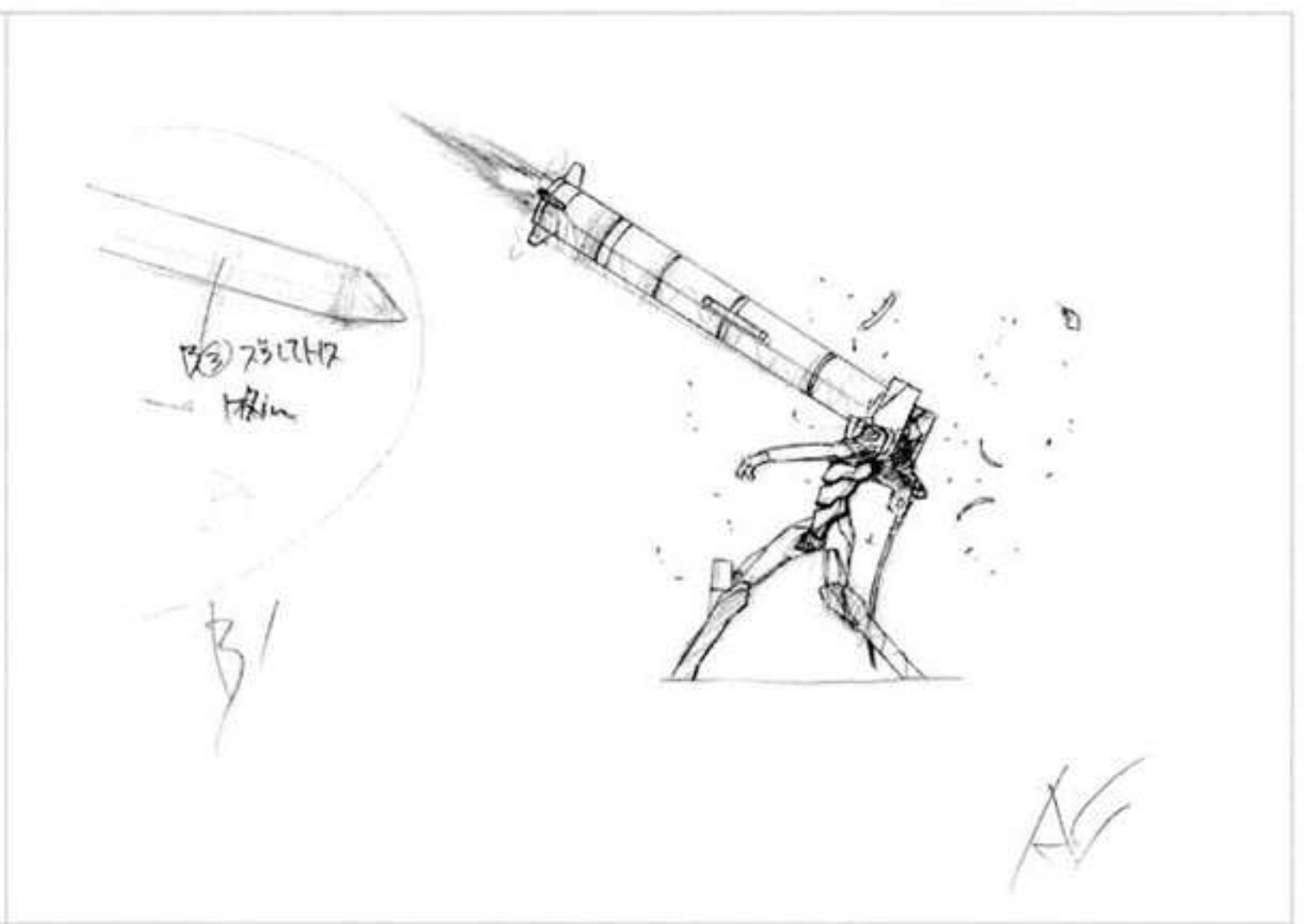
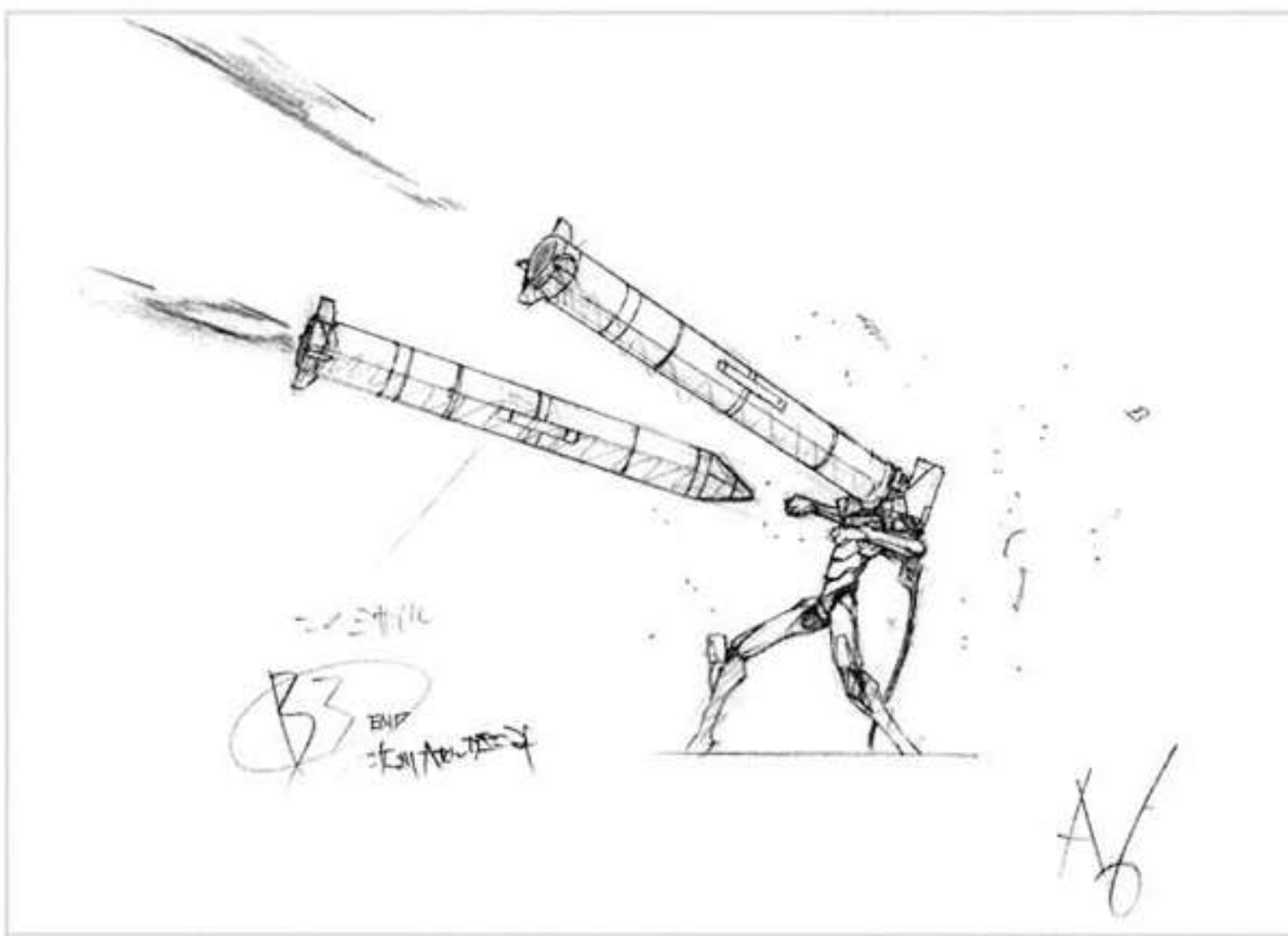

修正原画

修正原画

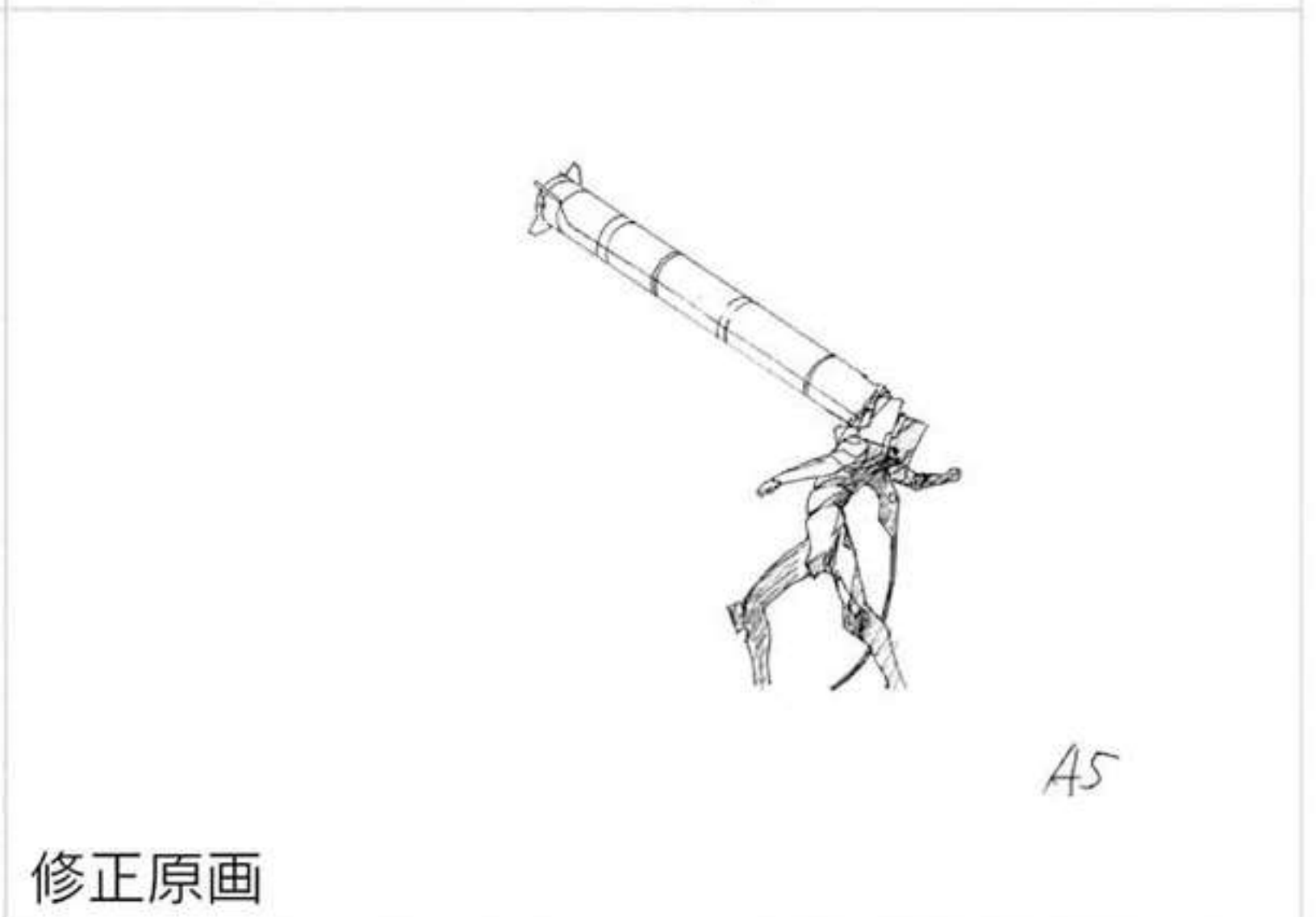
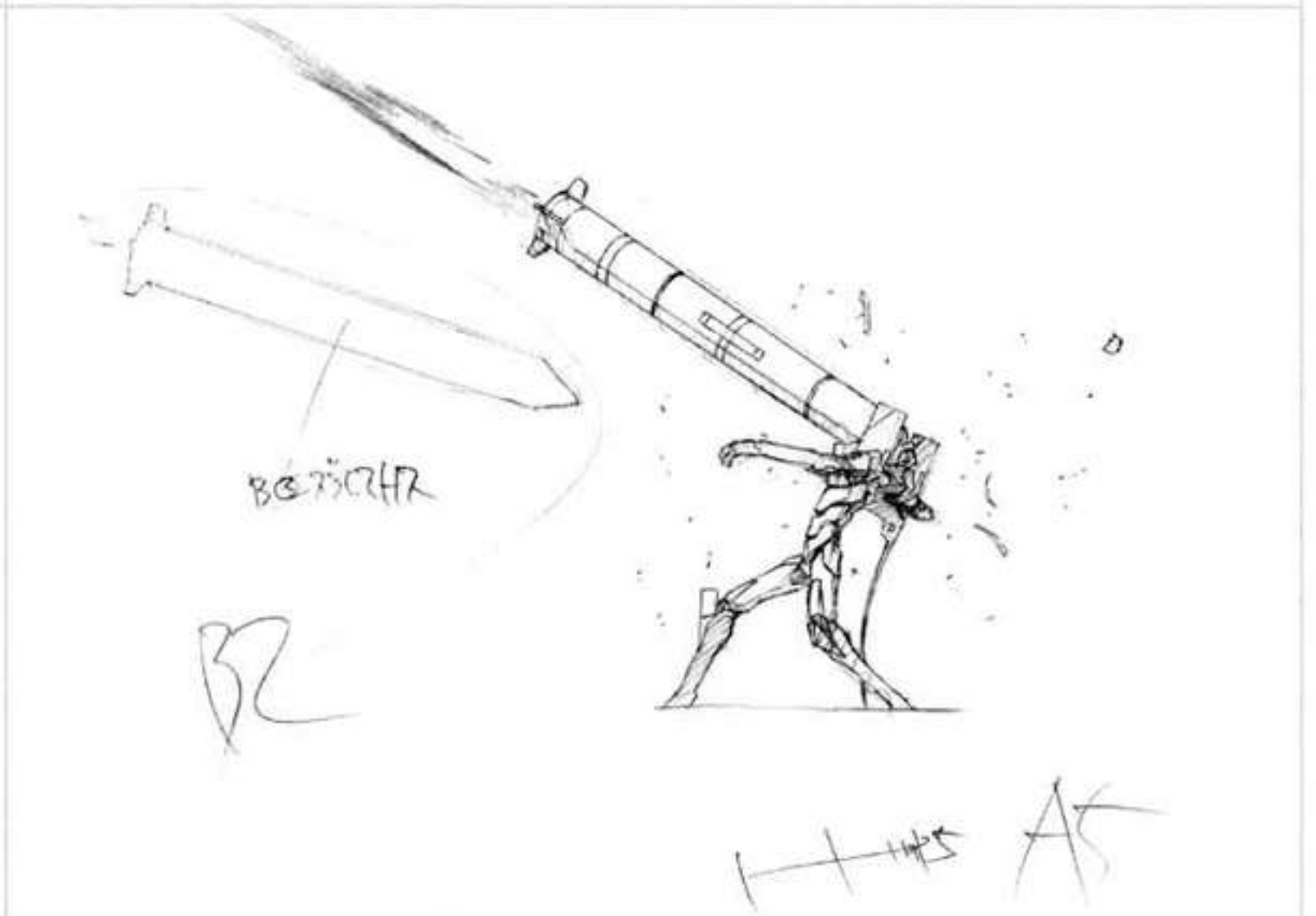
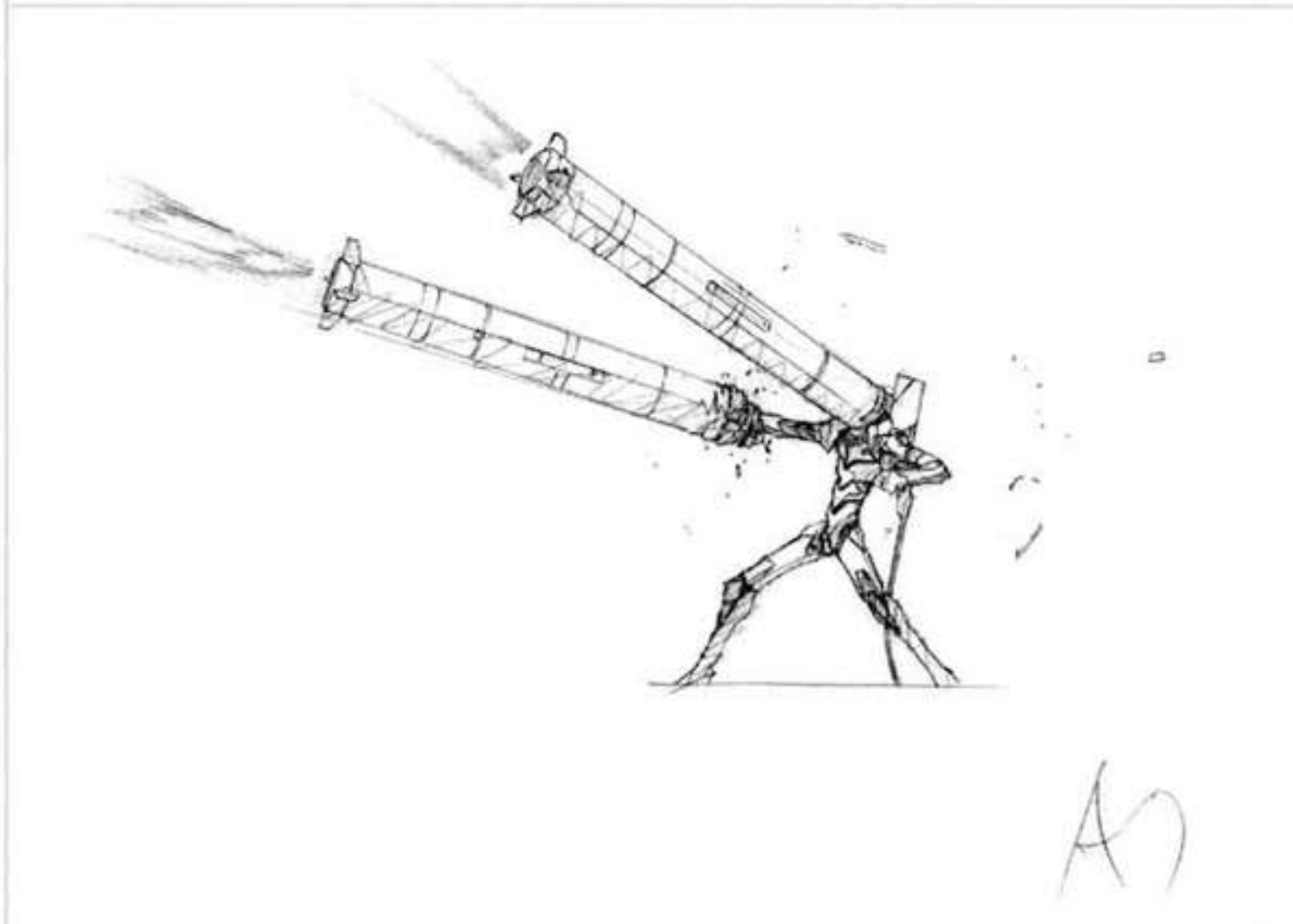

修正原画

修正原画



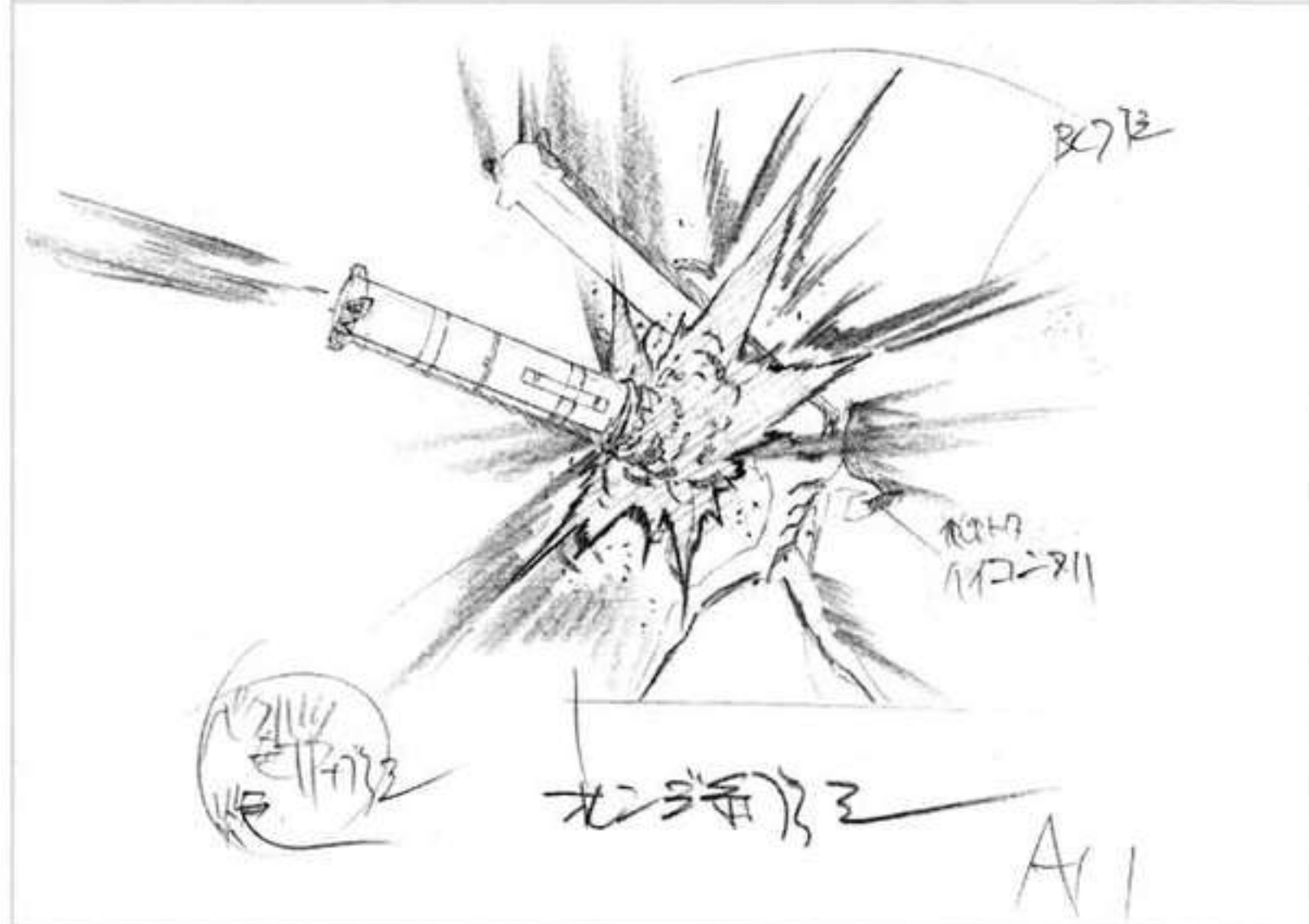
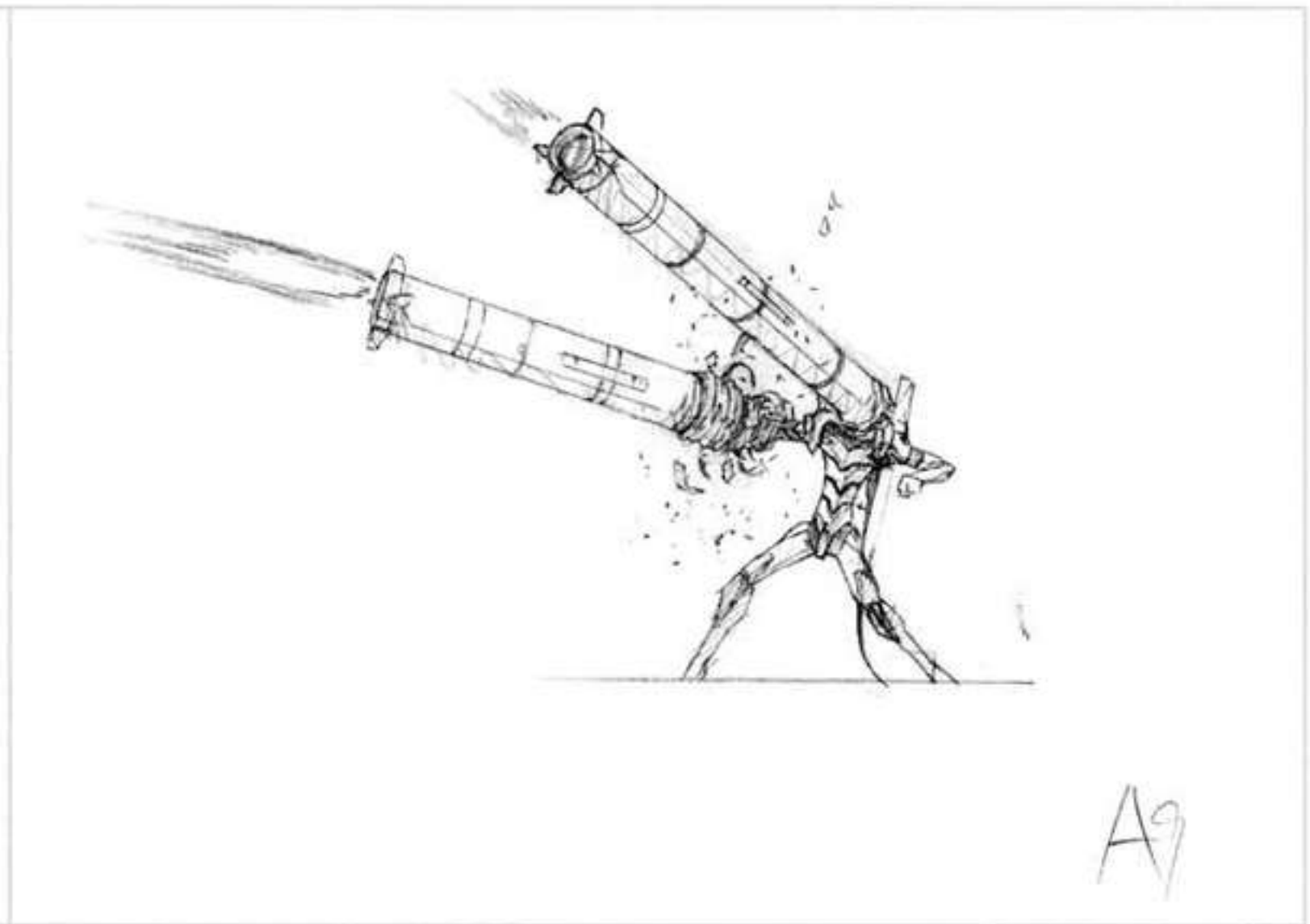
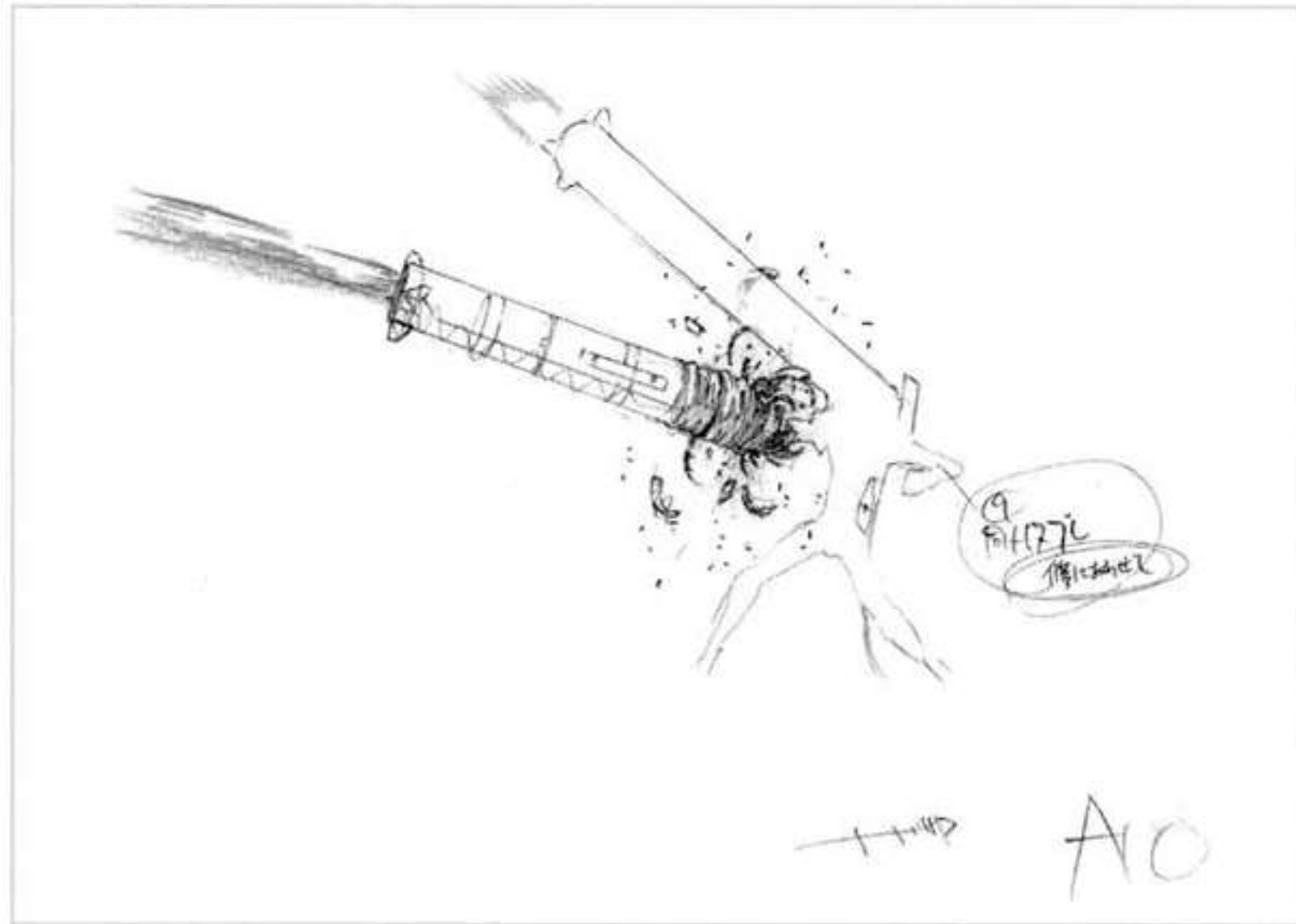
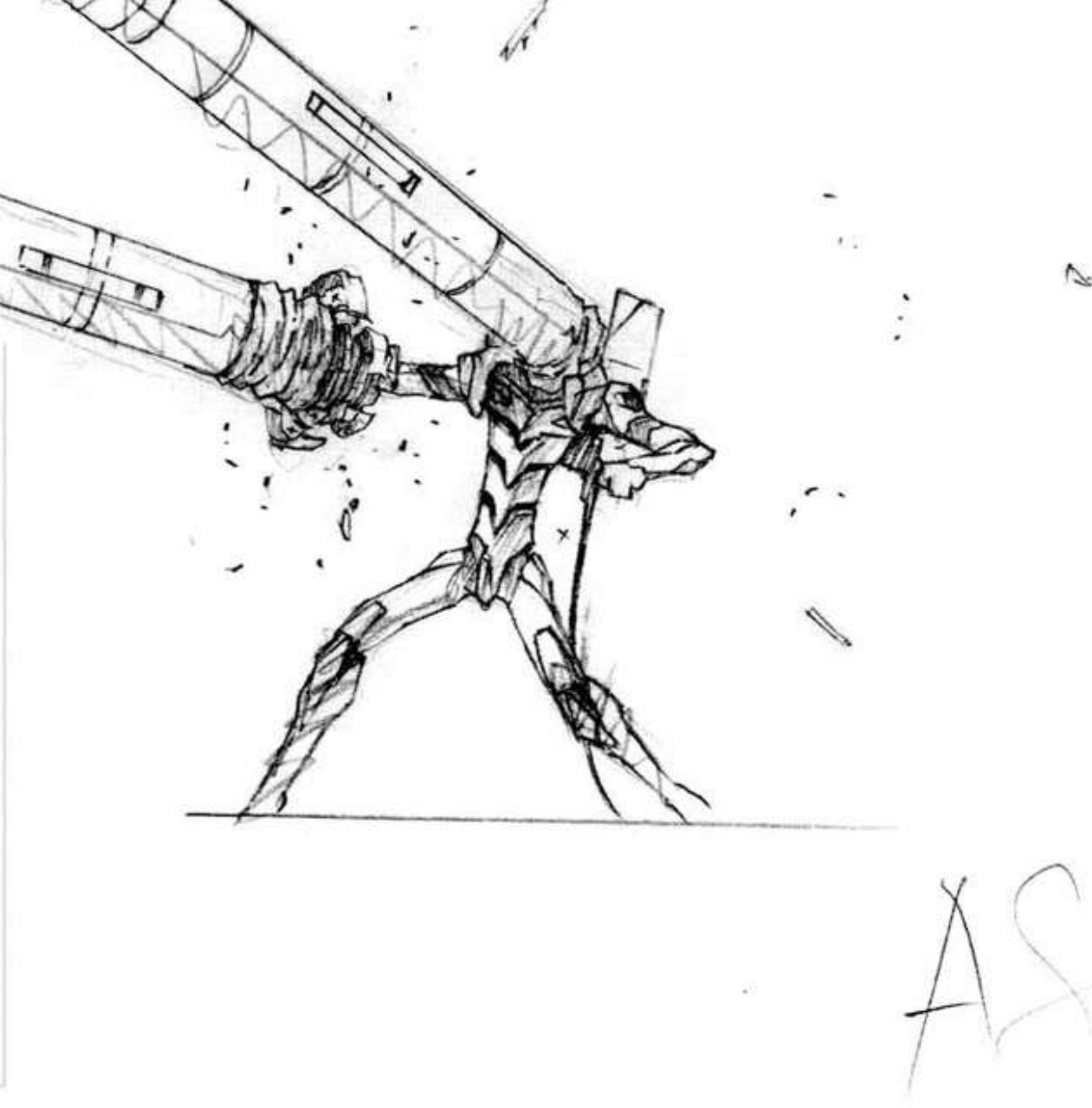
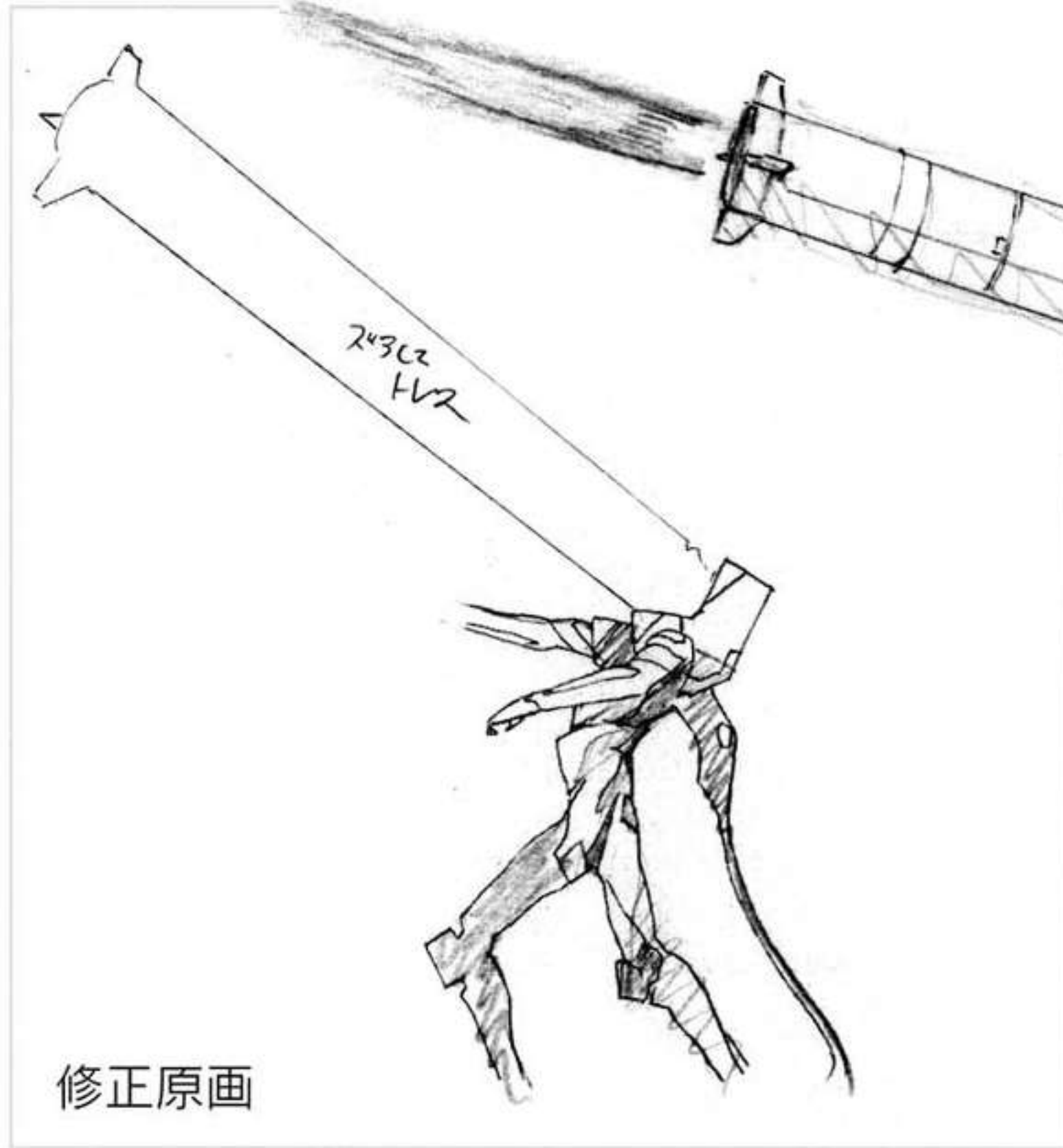



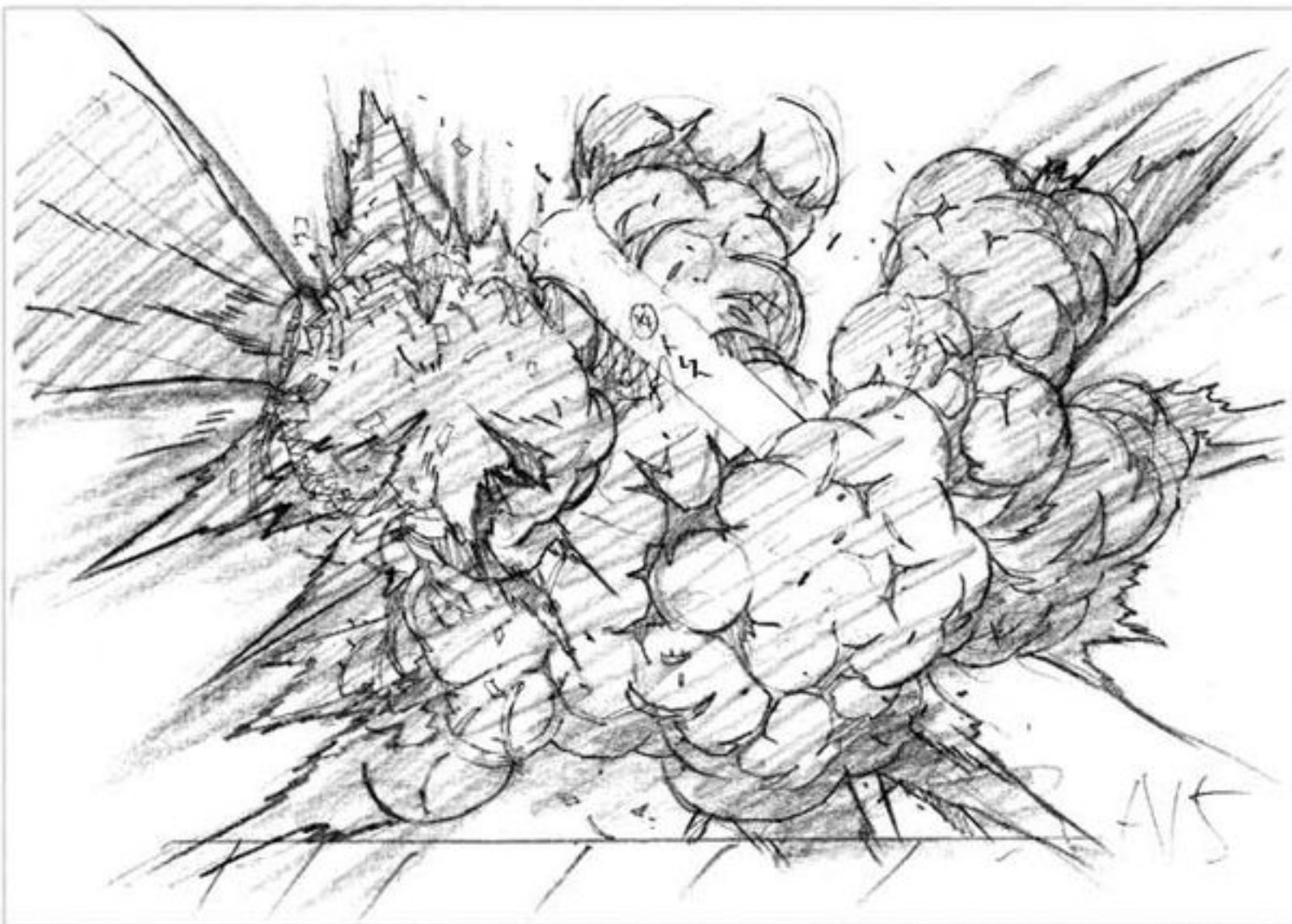

A15



(110221)

A11

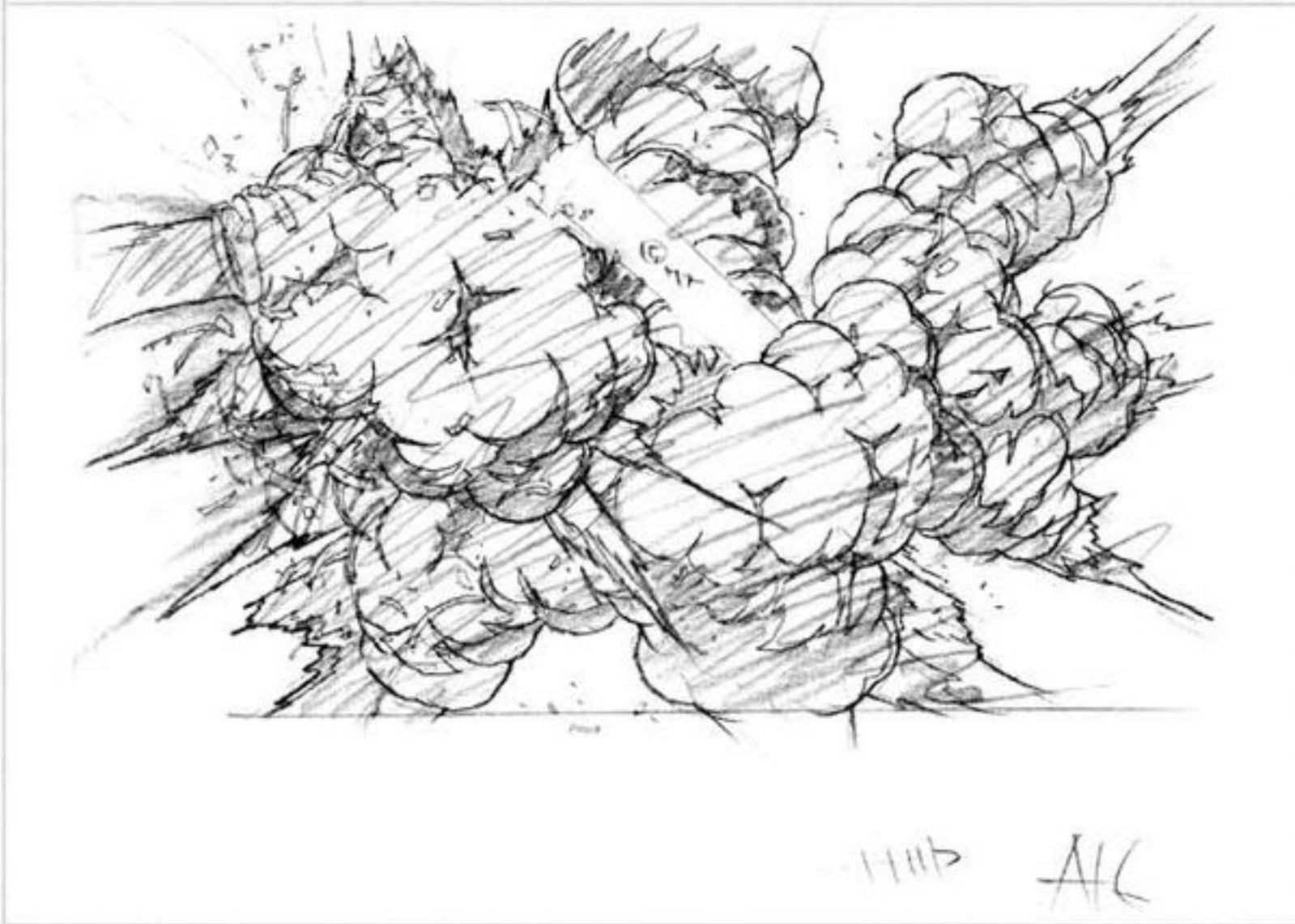

11111 A16

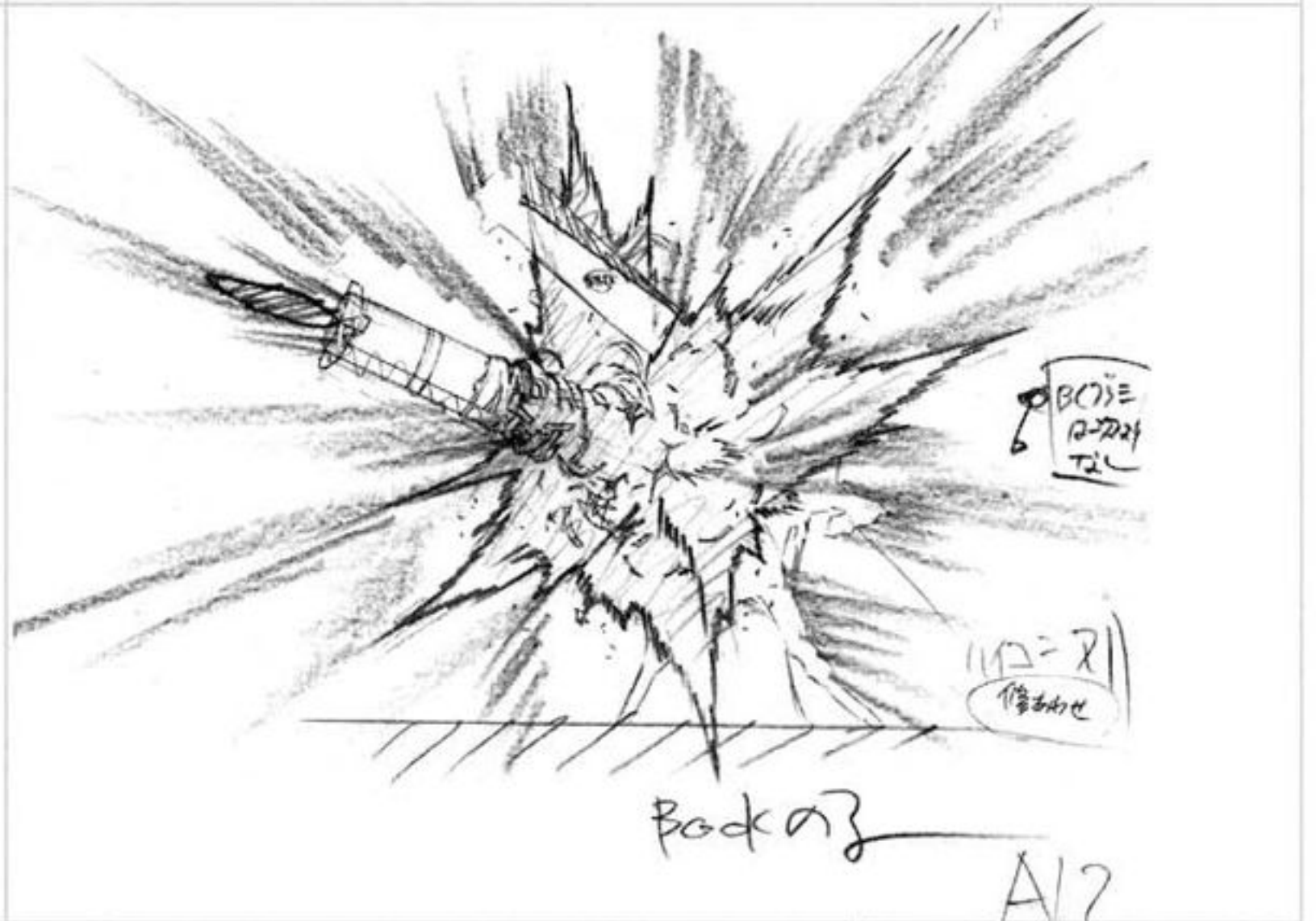

(110221)

(110221)

Backの?

A17

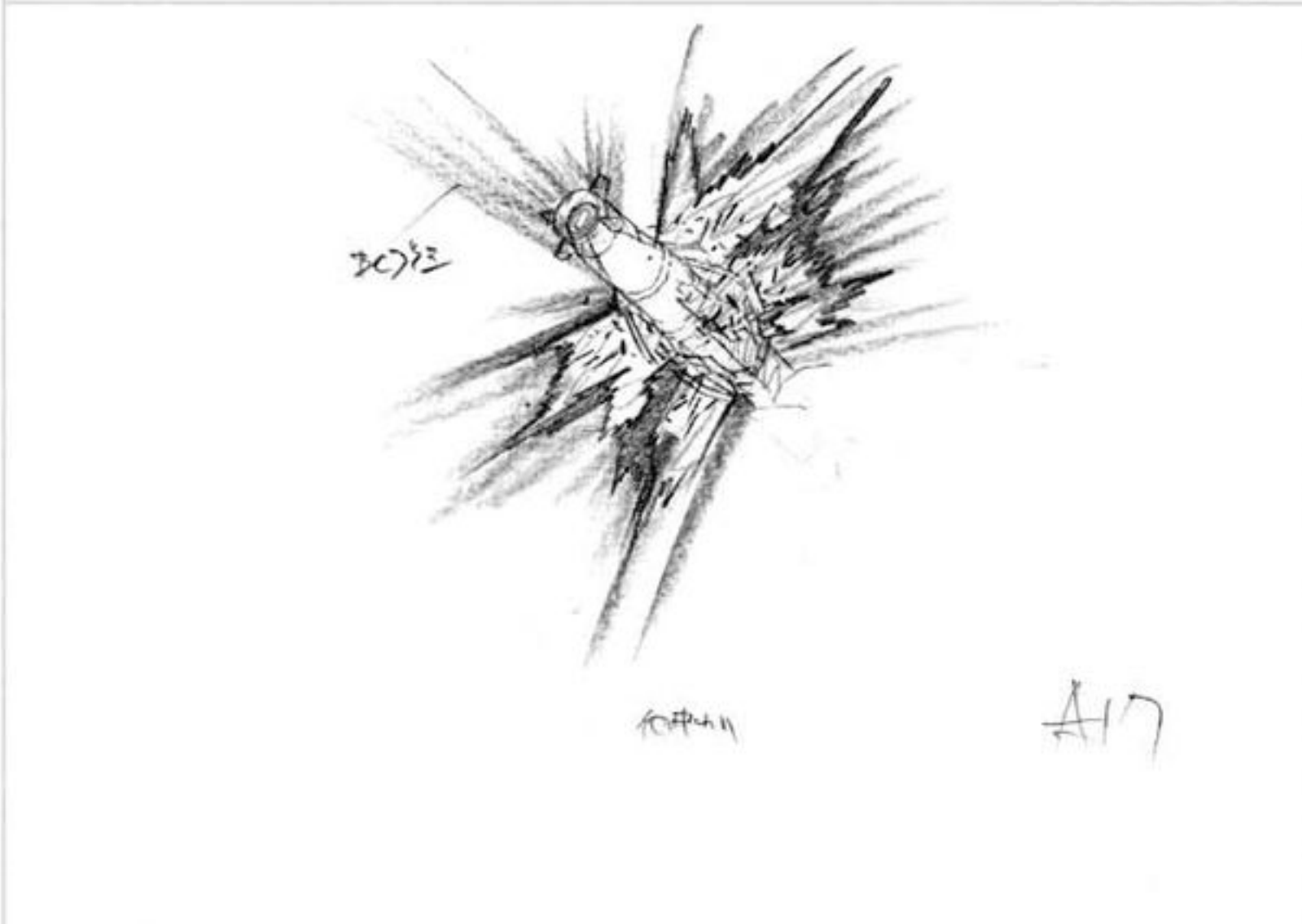

2022

11111

A17

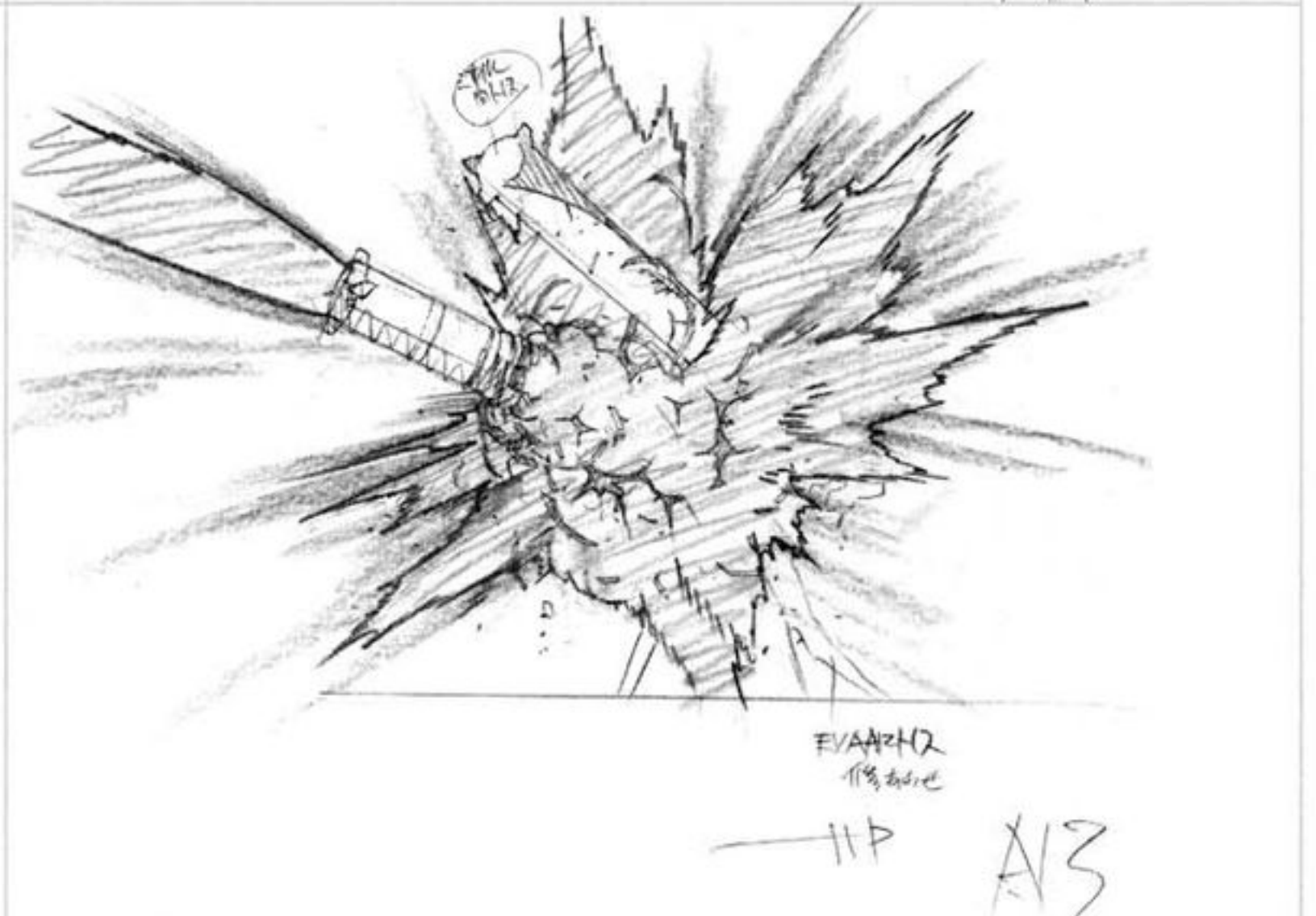

(110221)

EVA1312

11111

A13

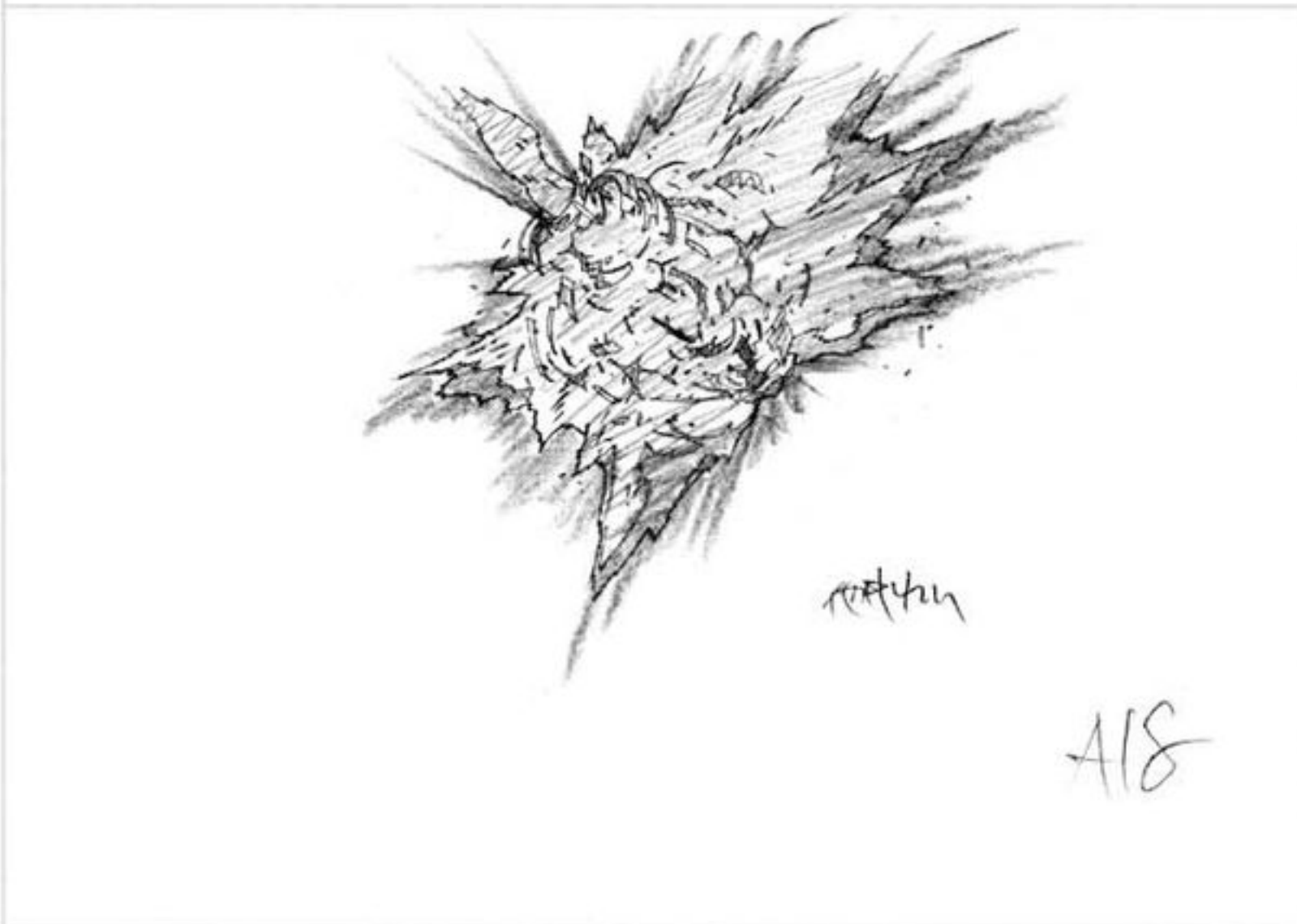

11111

A18

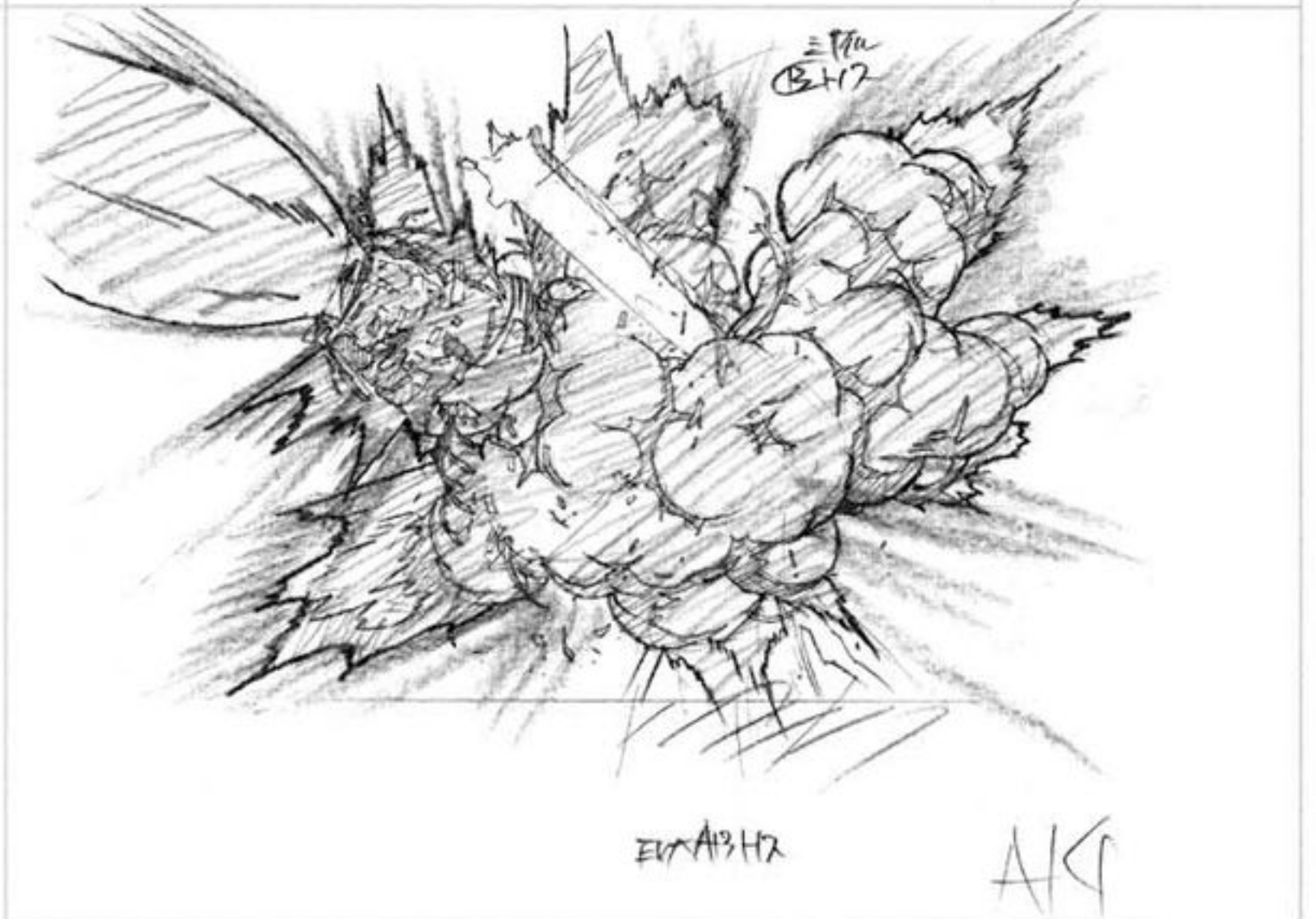

(110221)

EVA1312

A19







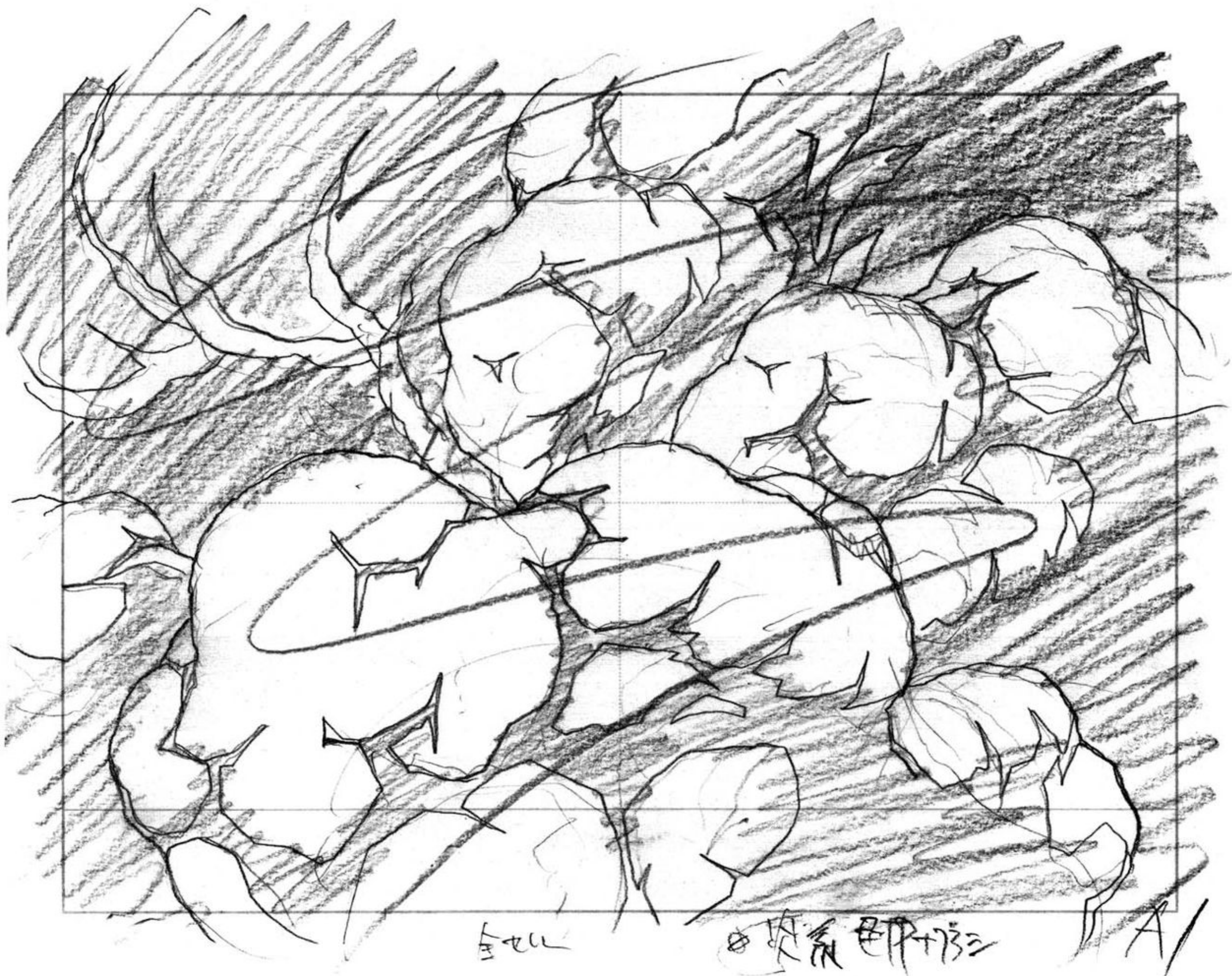

#25-C360

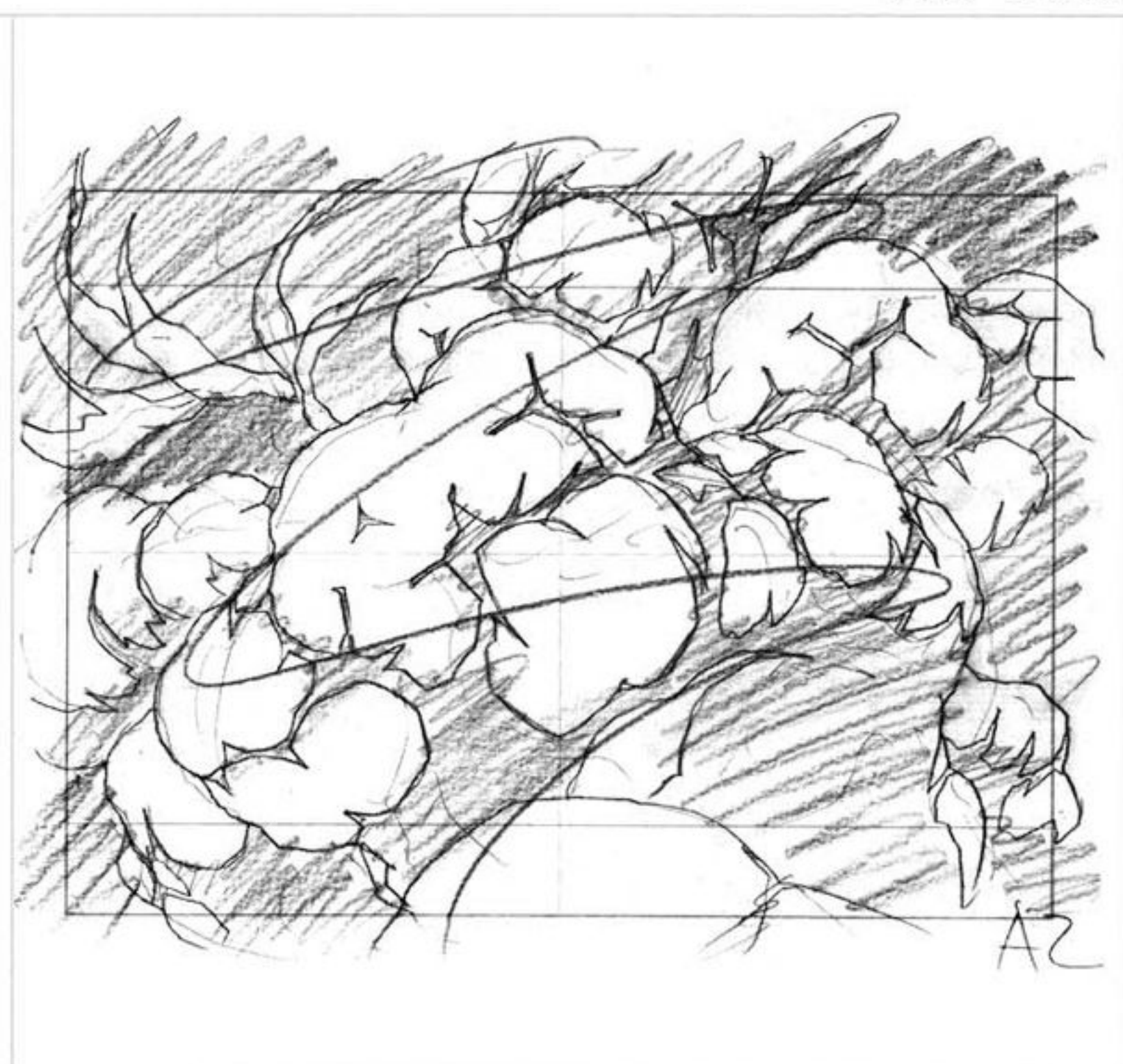



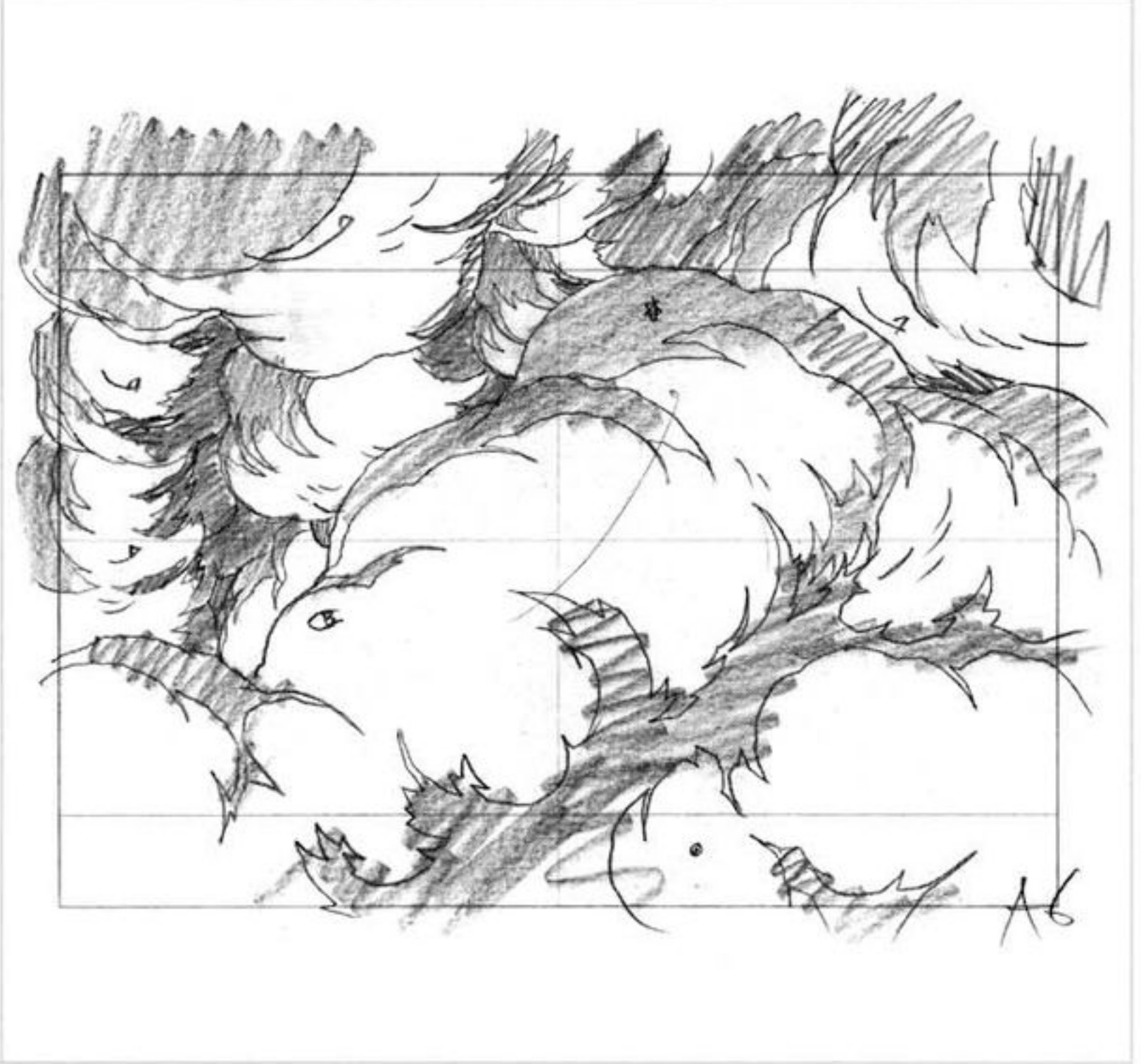
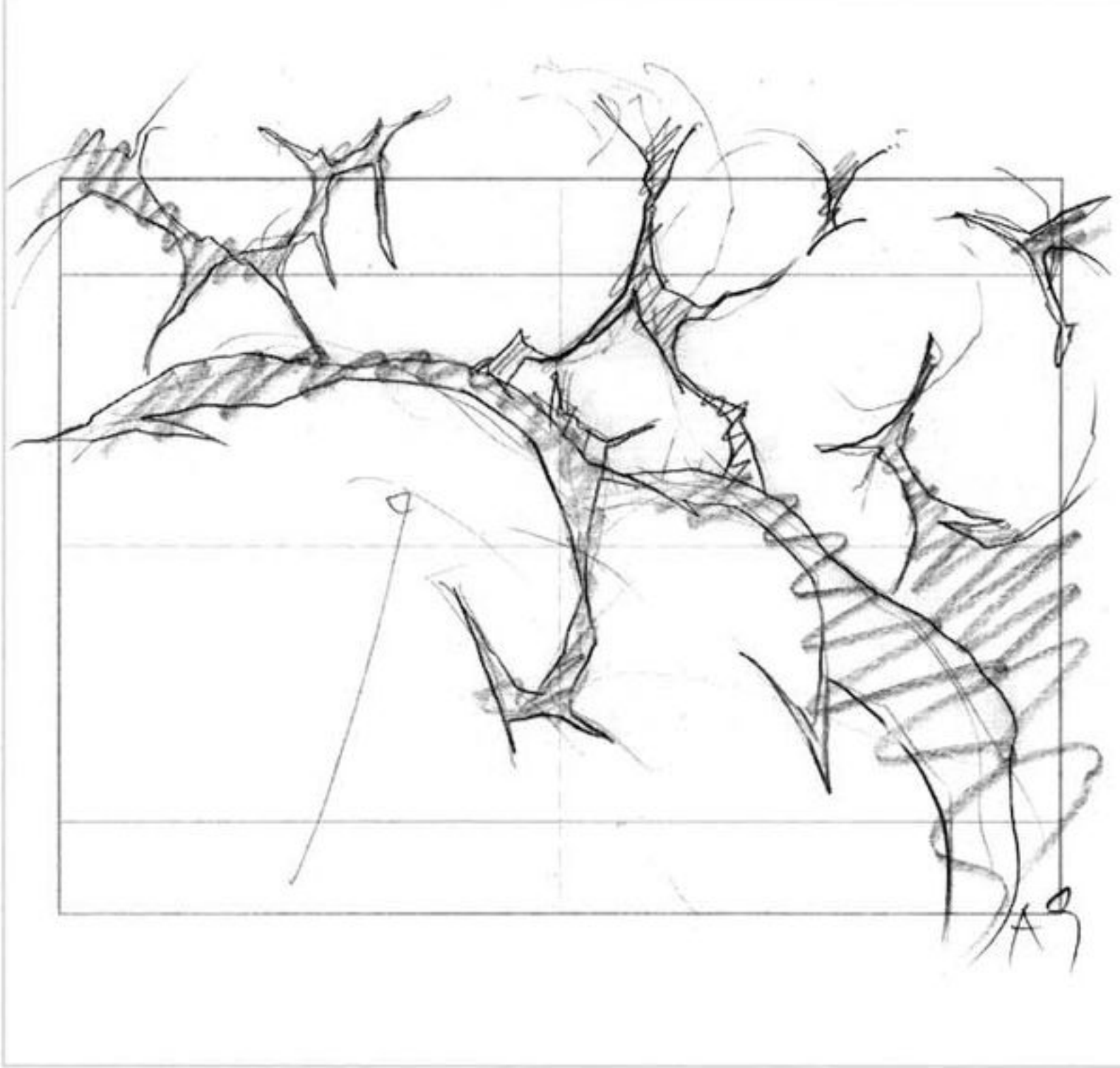
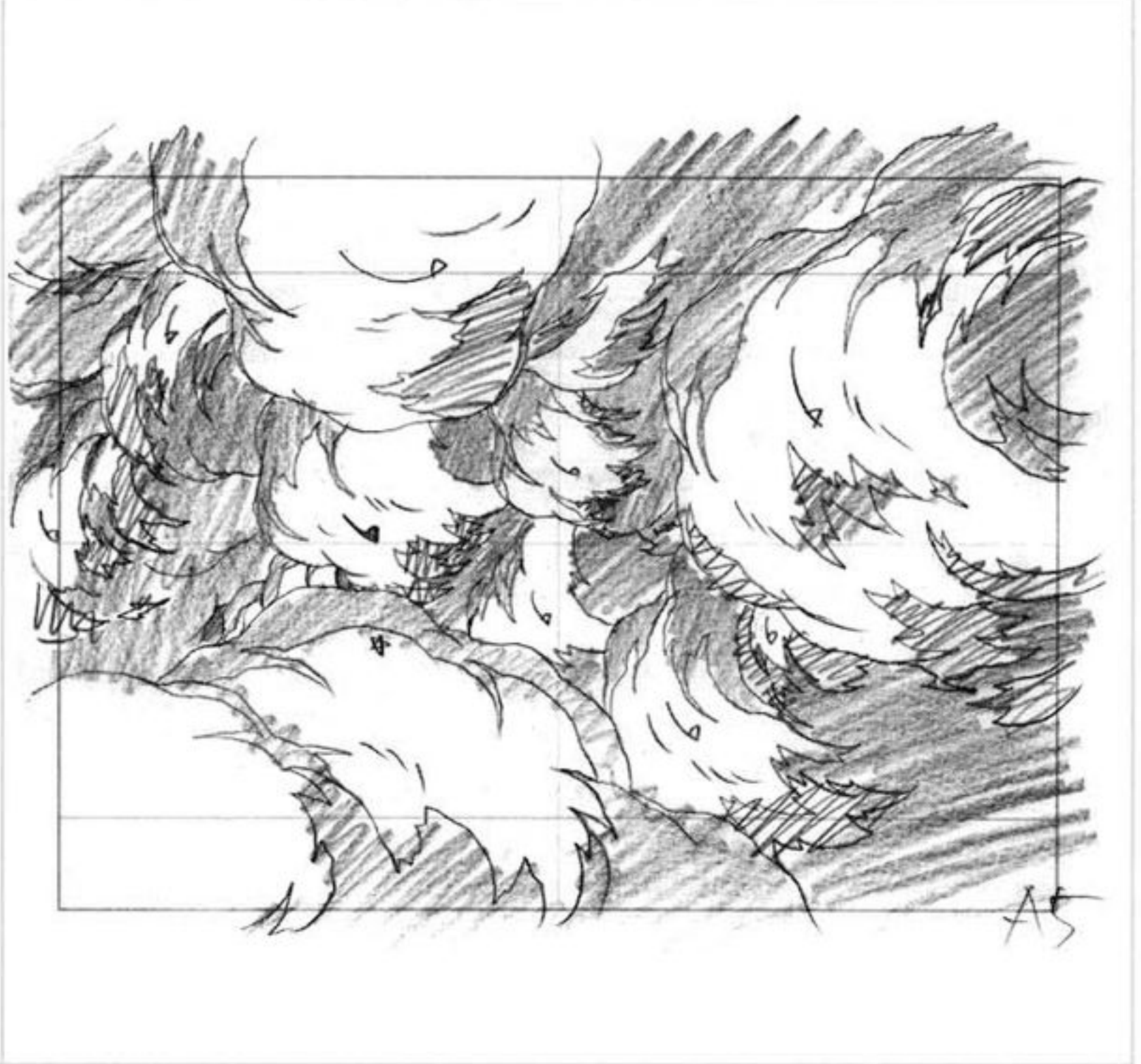
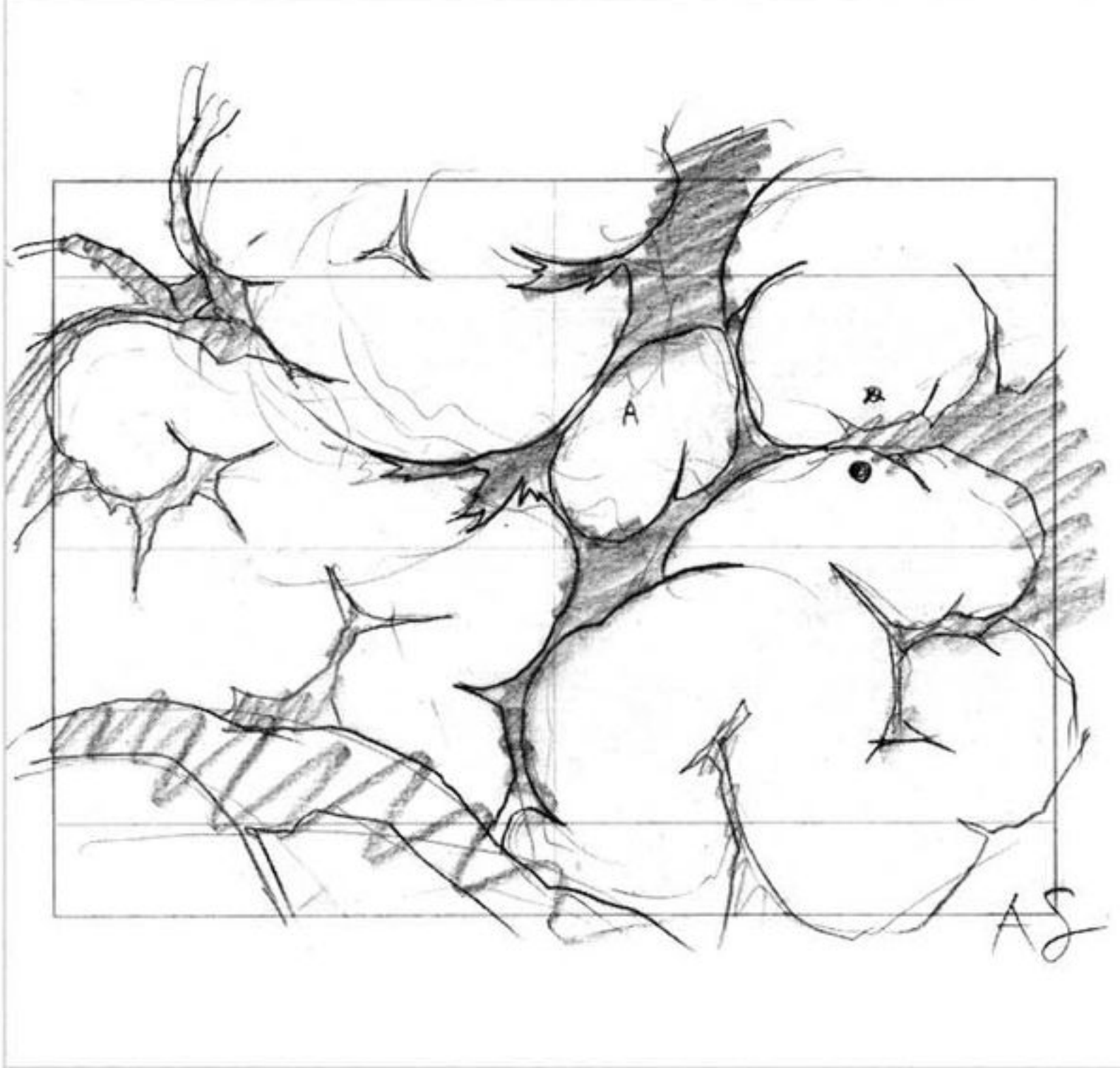
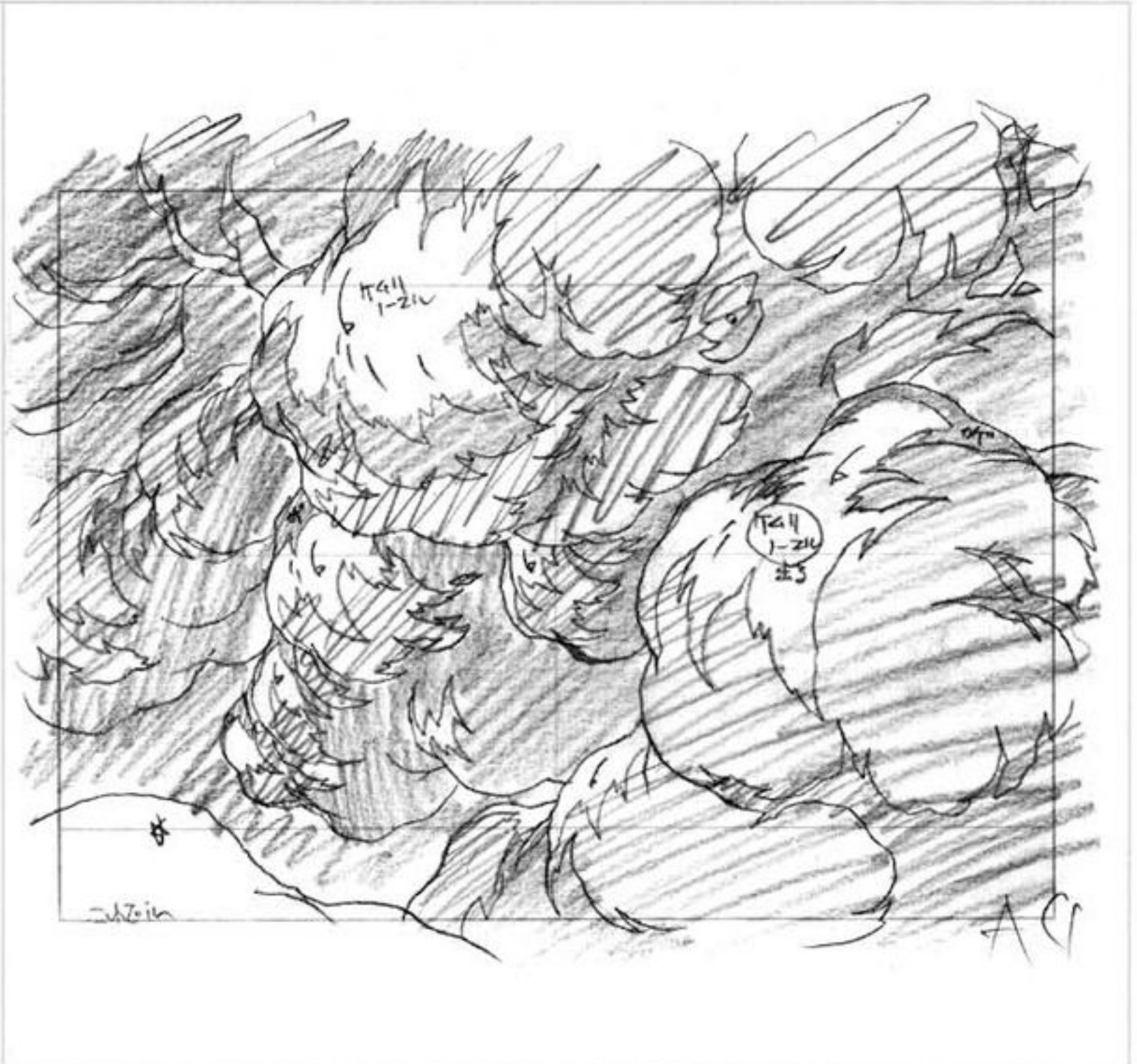



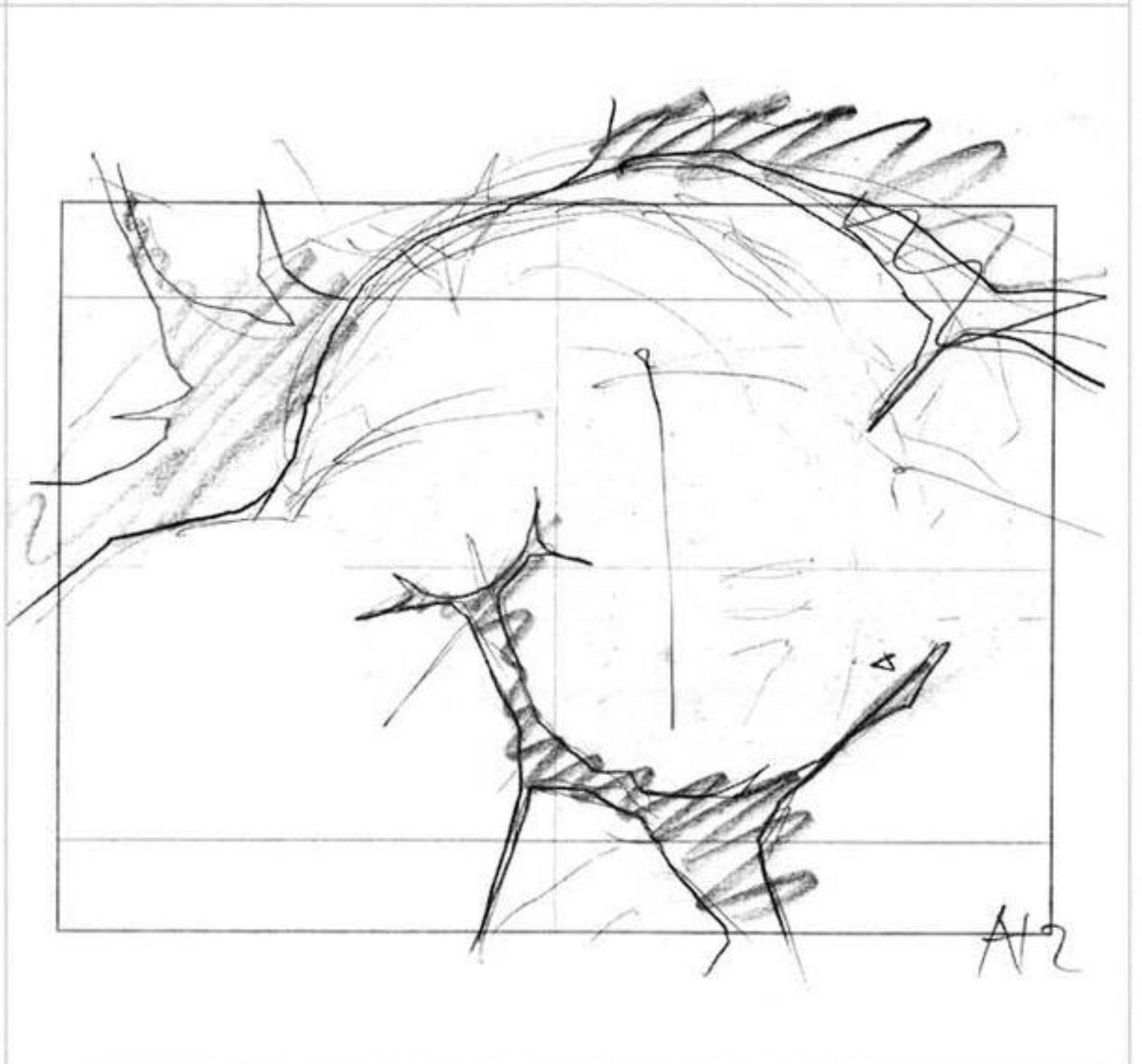
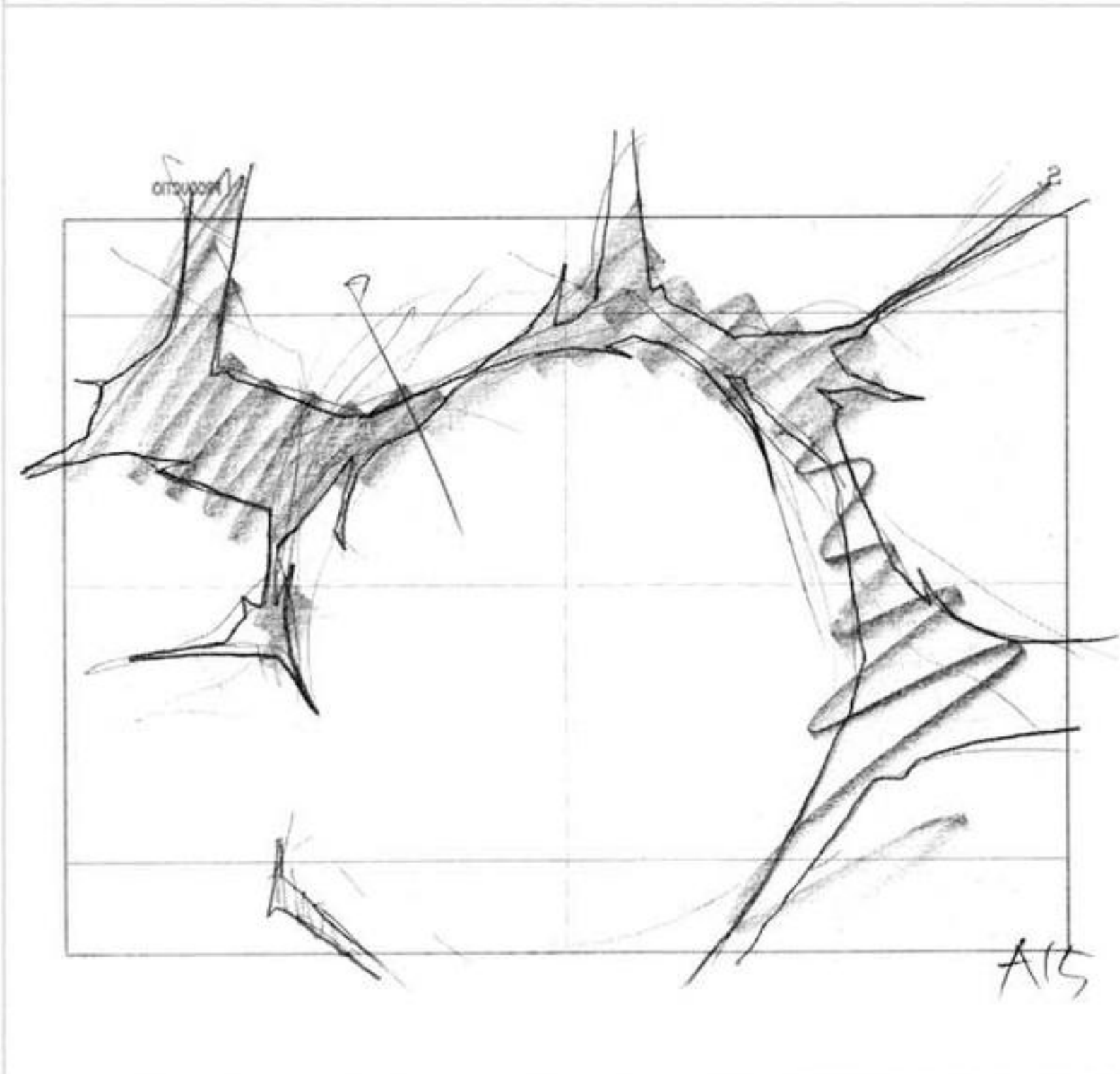
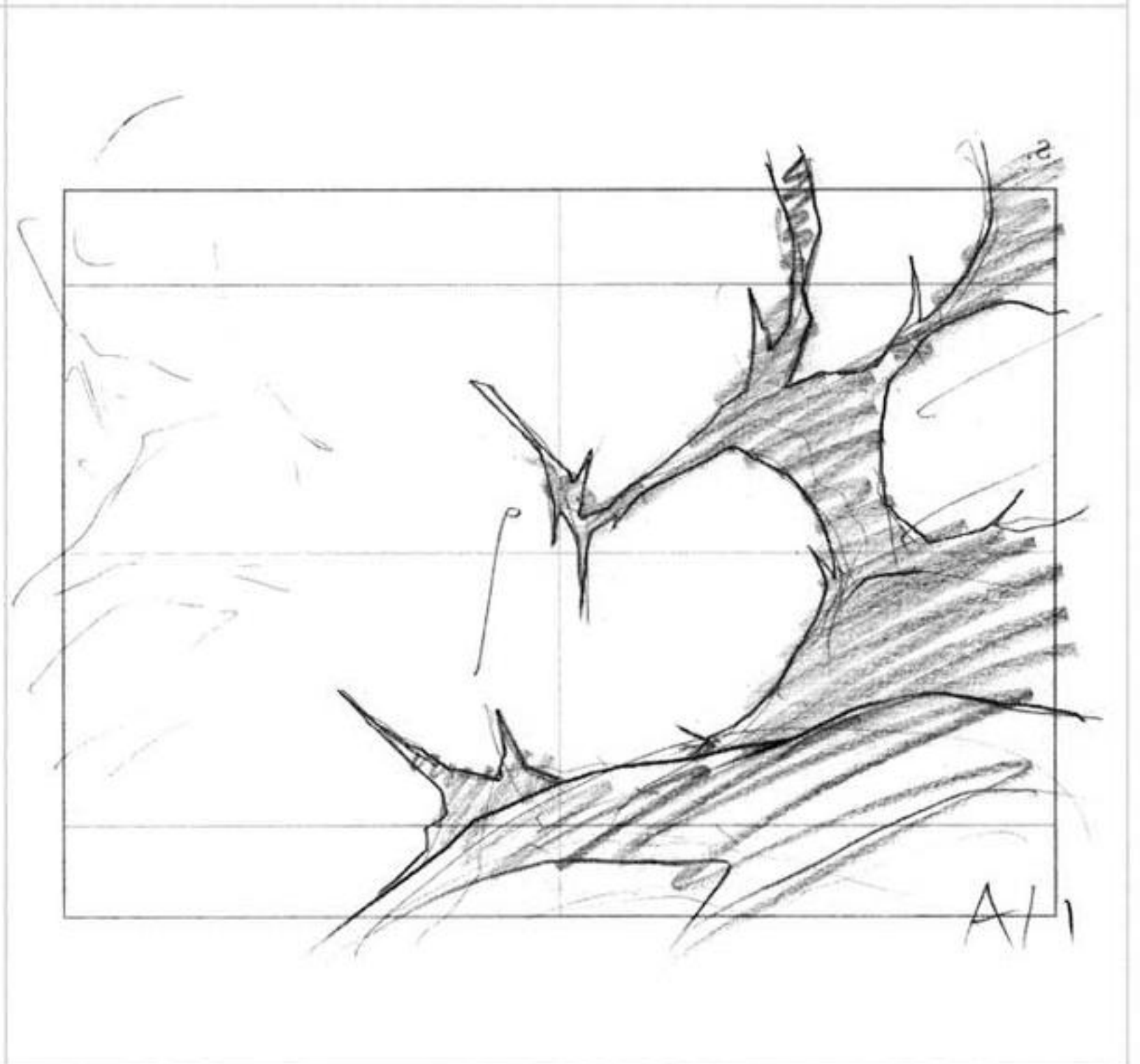
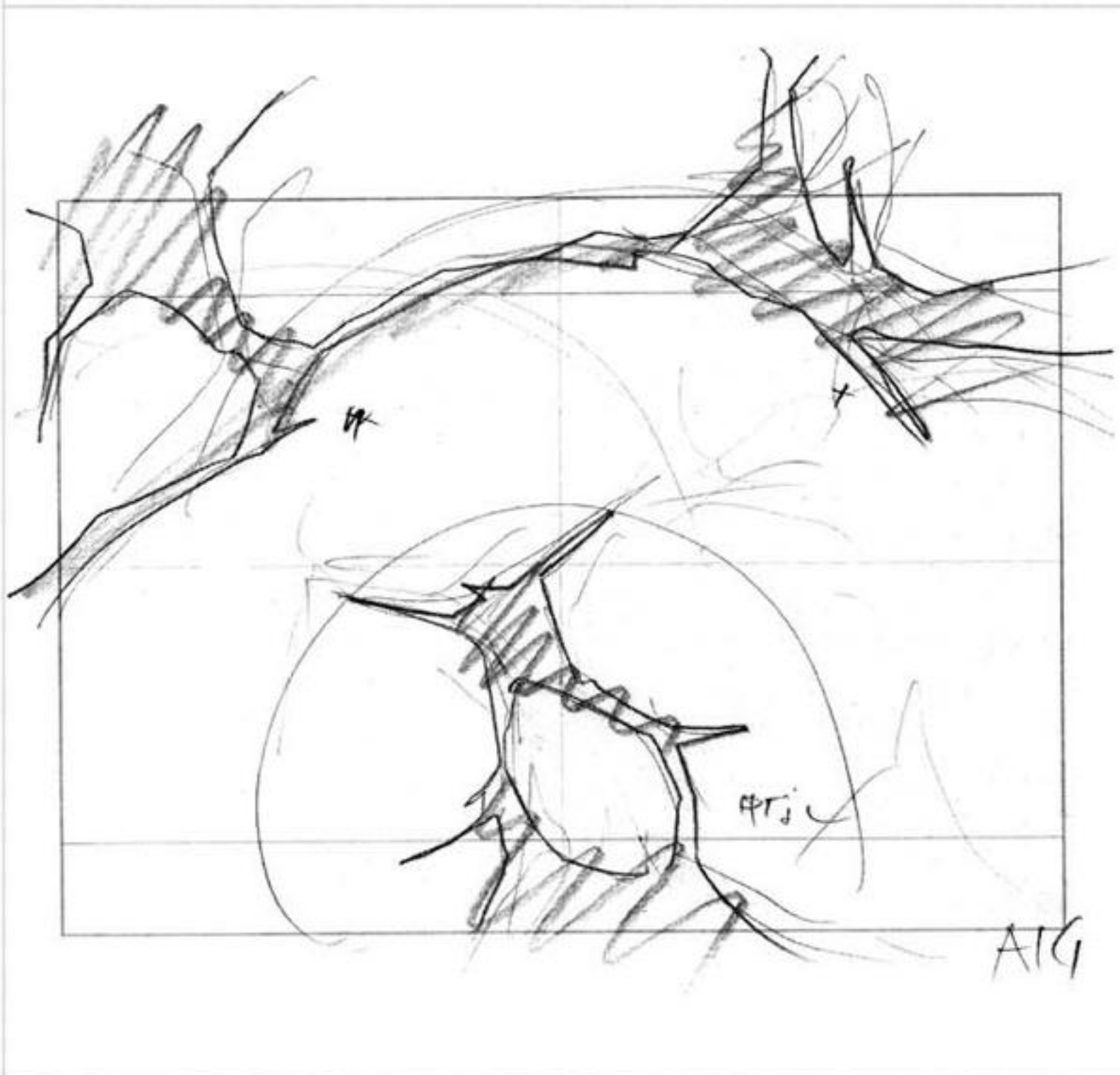
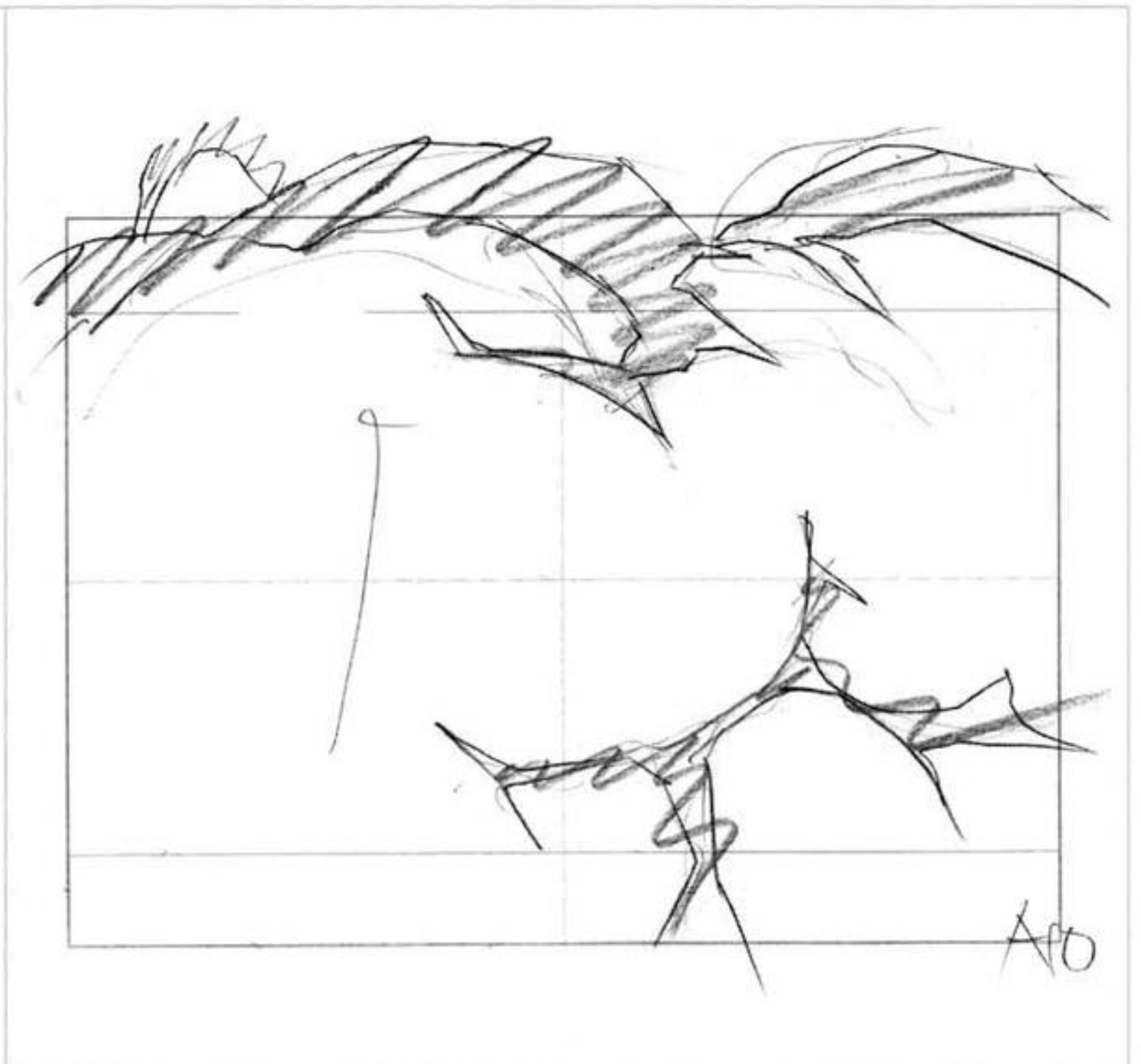
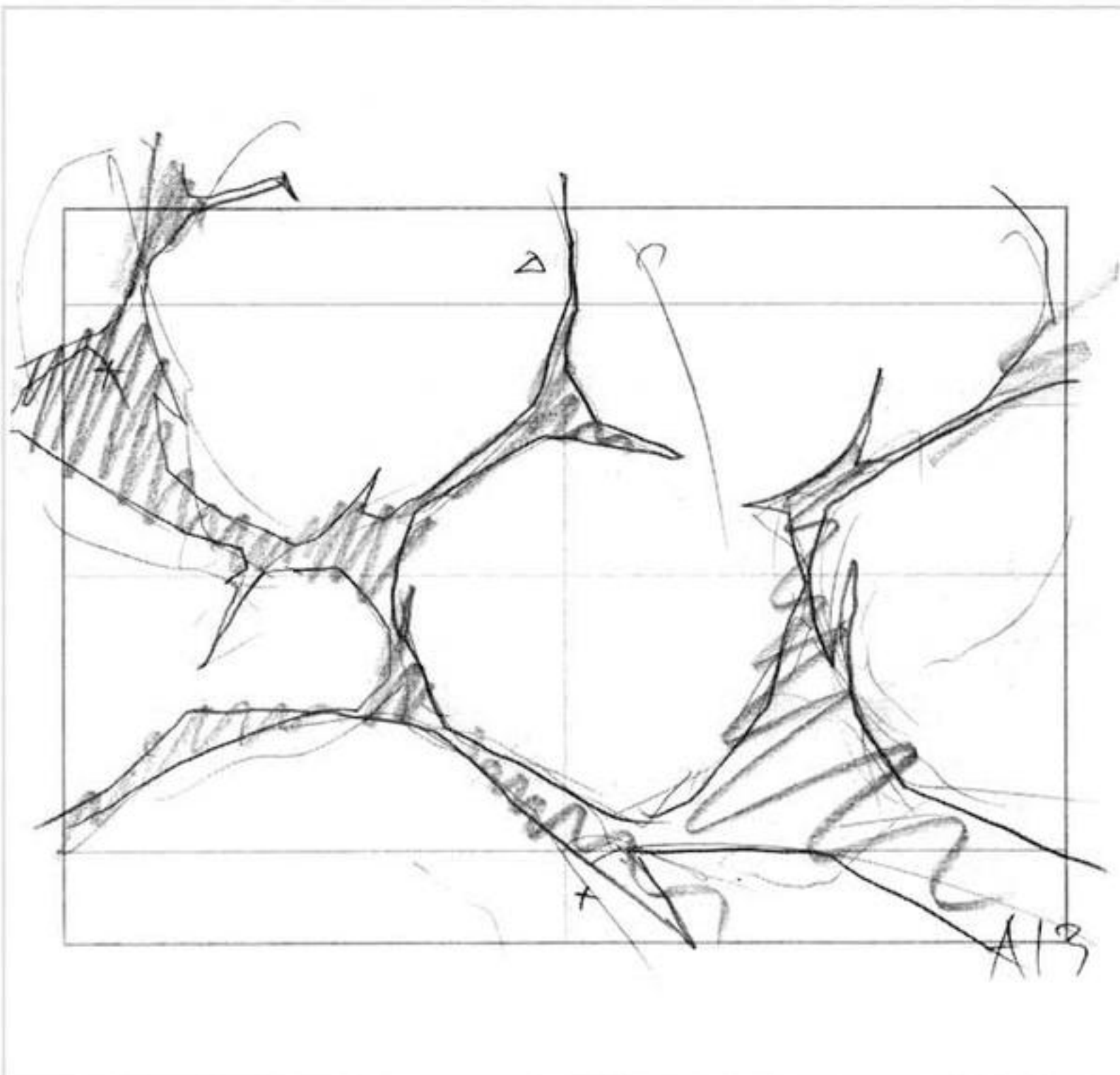



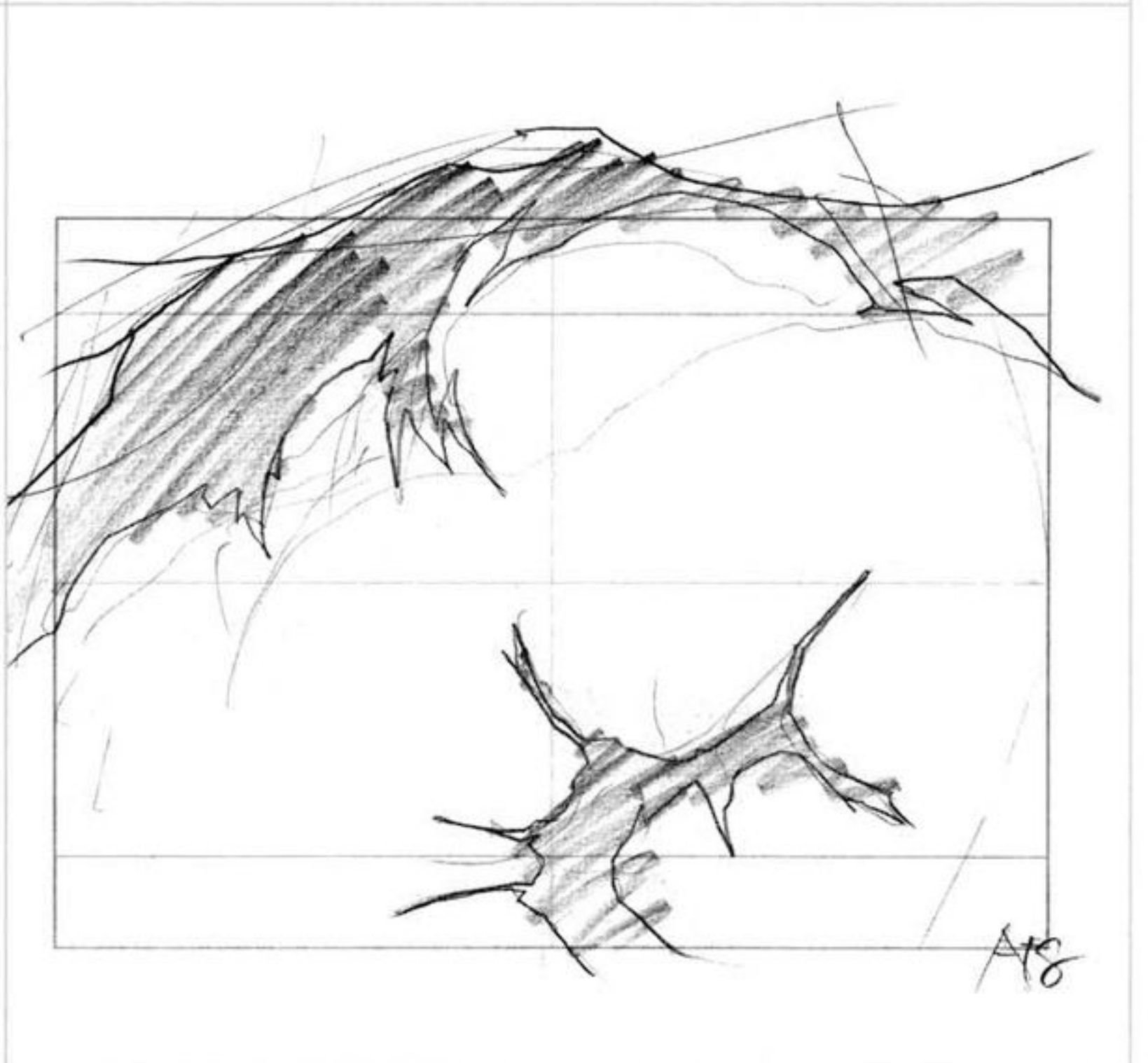
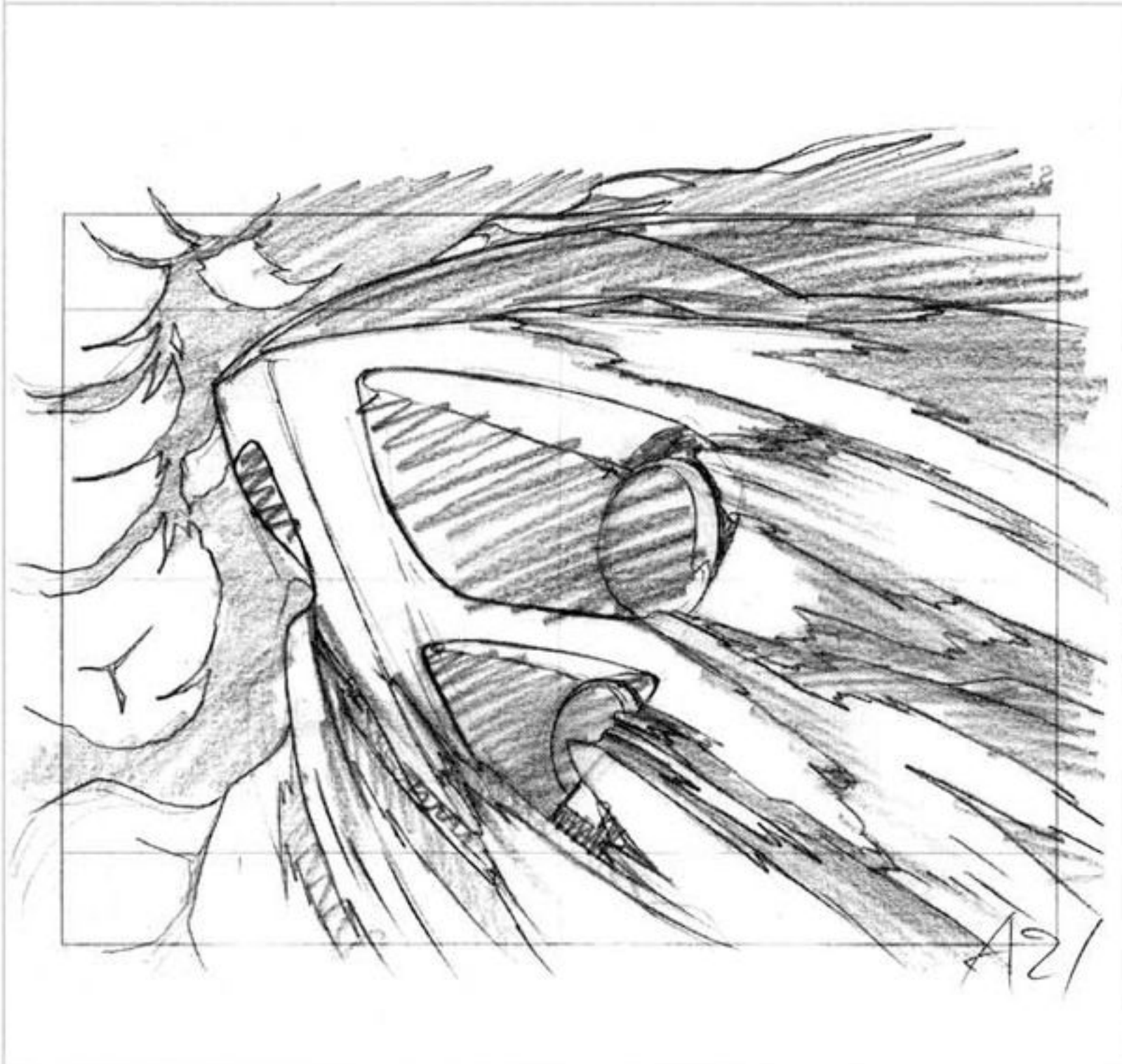
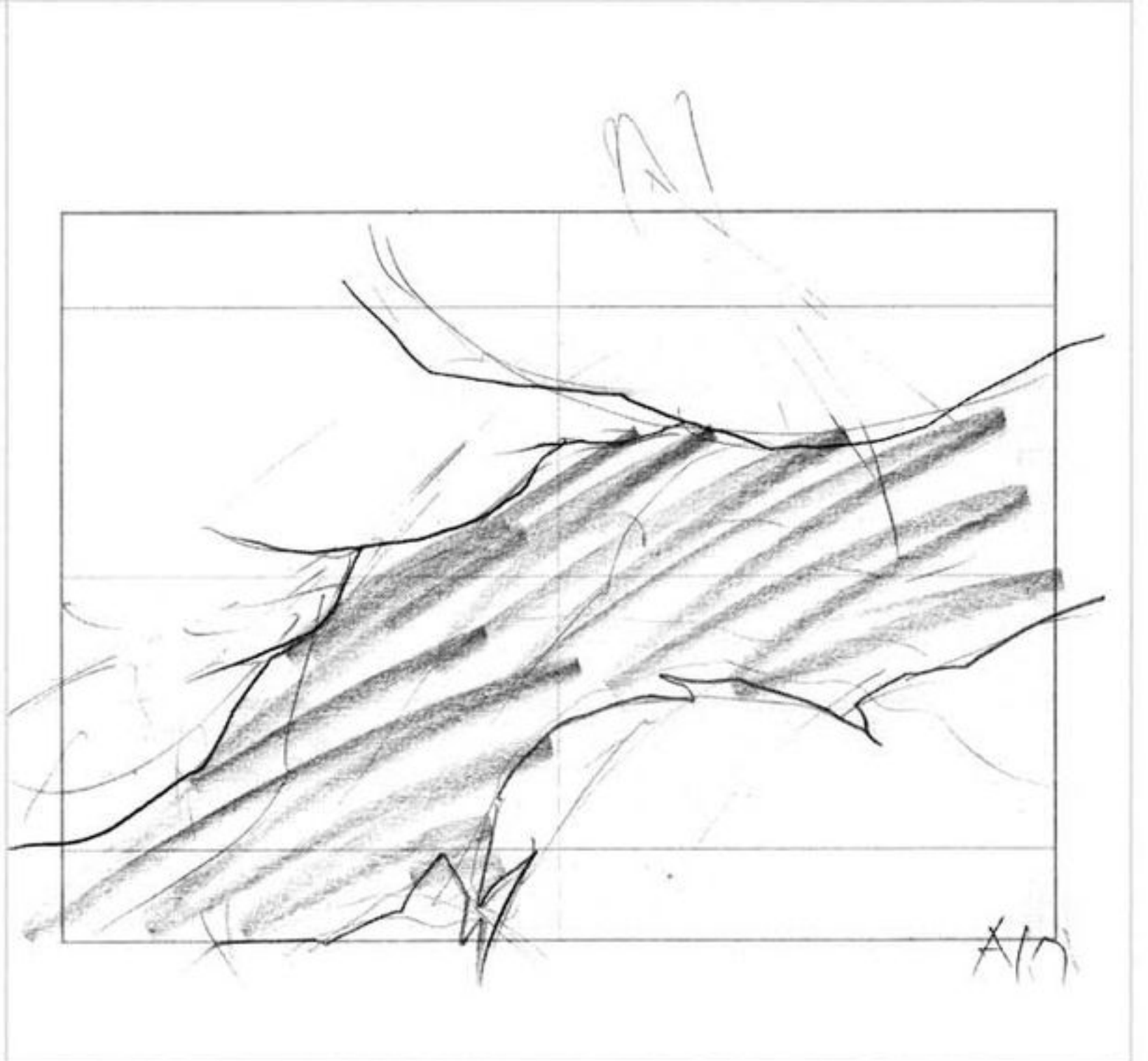
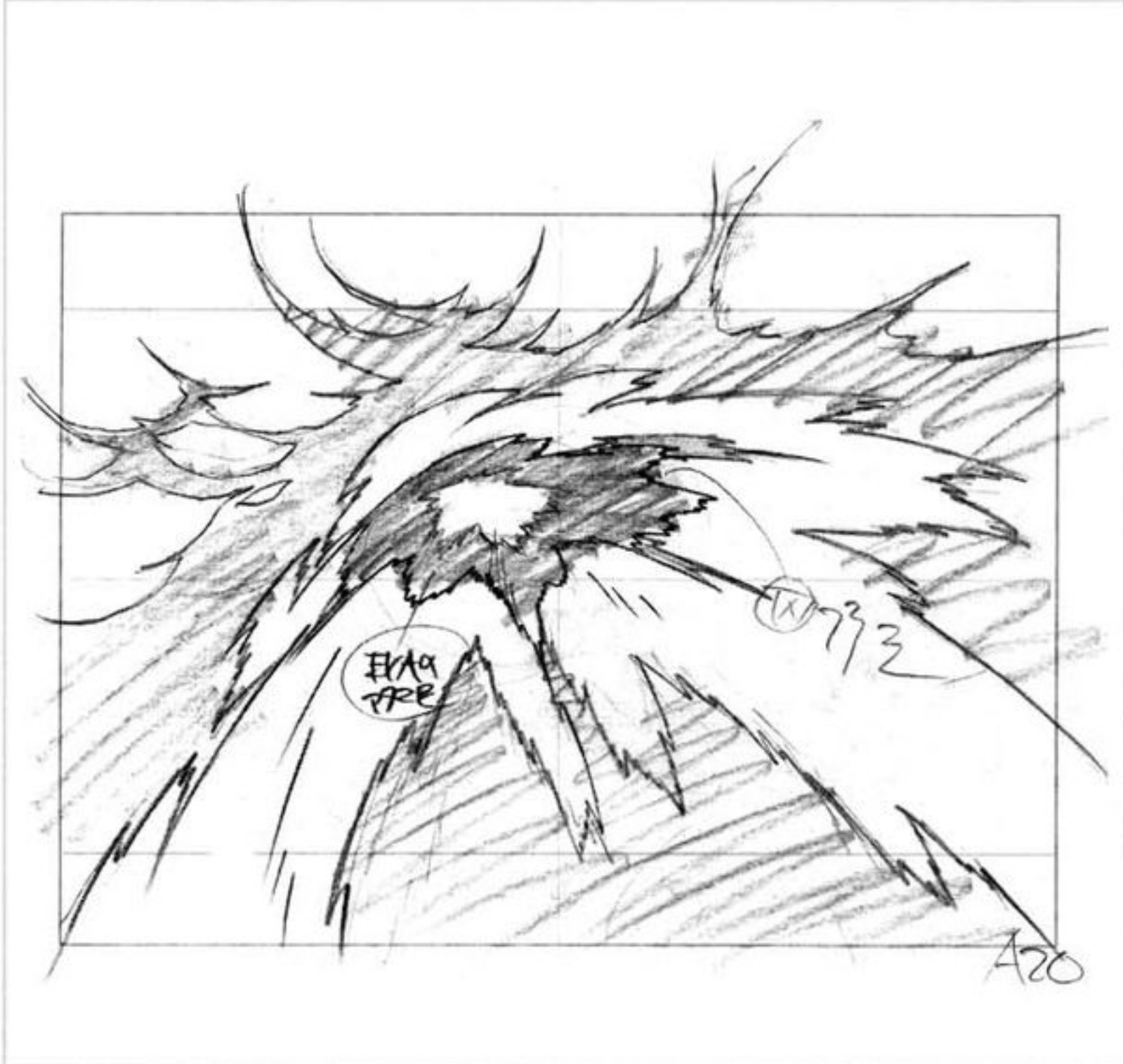
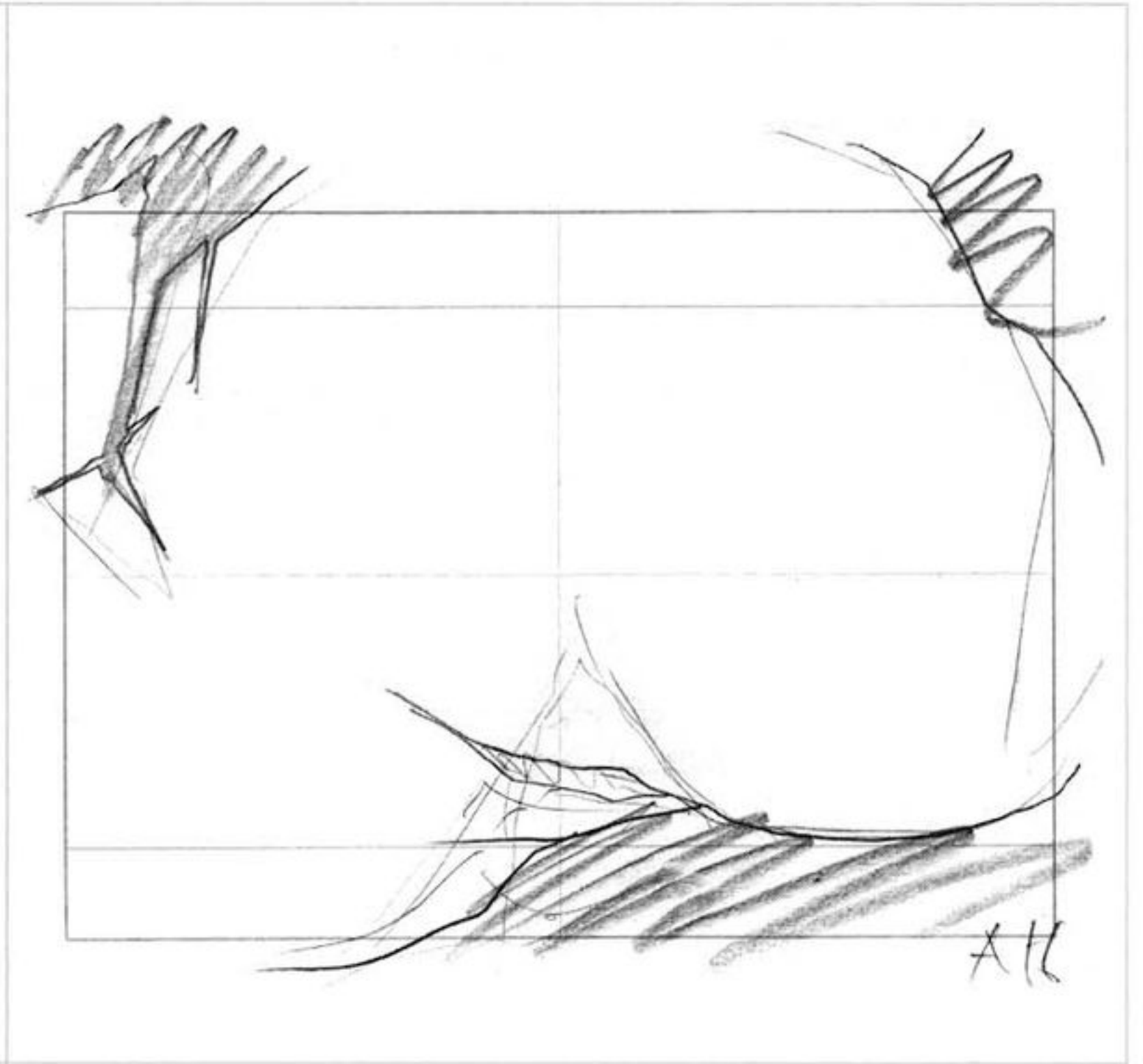
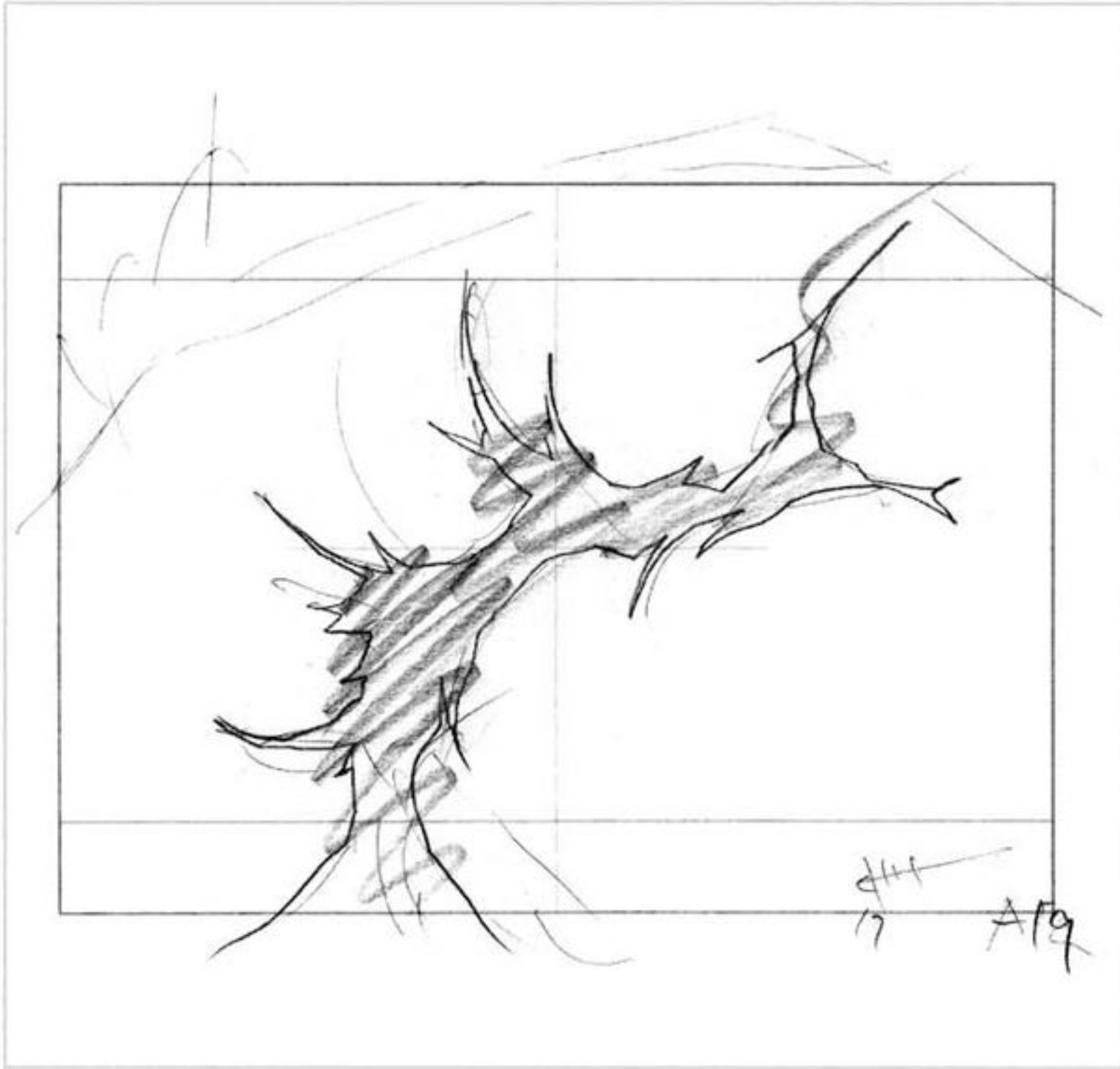



修正原画

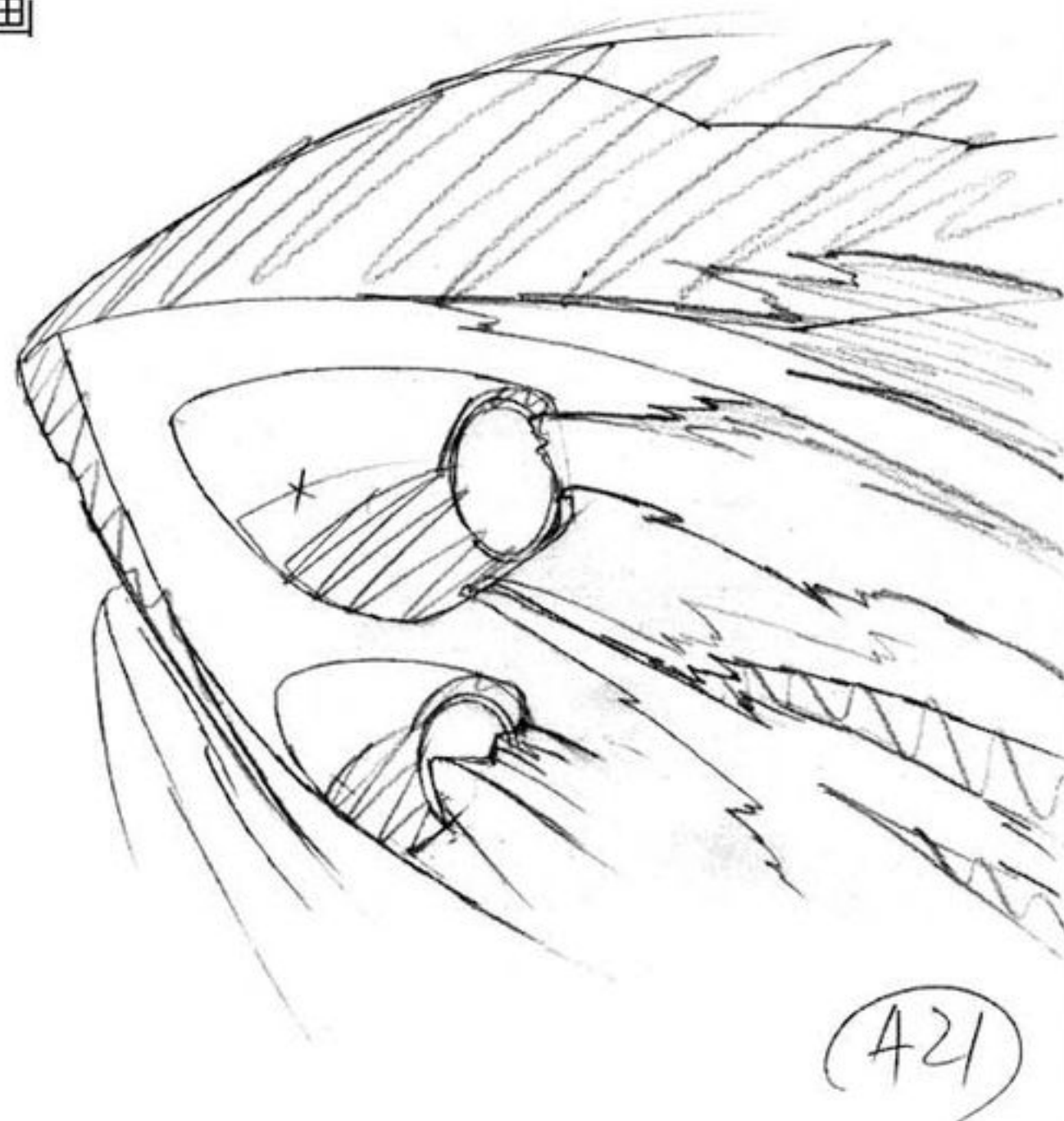
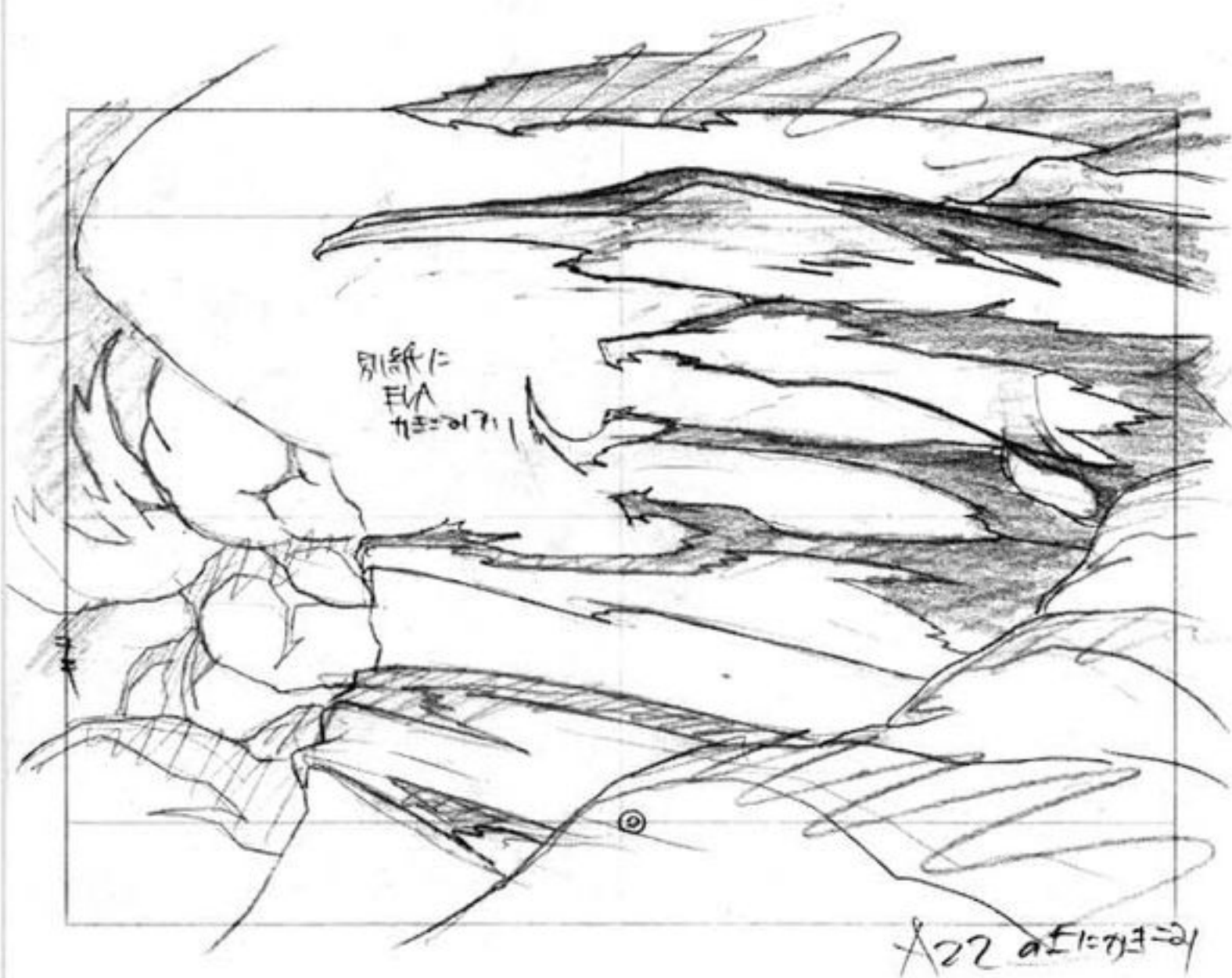

修正原画

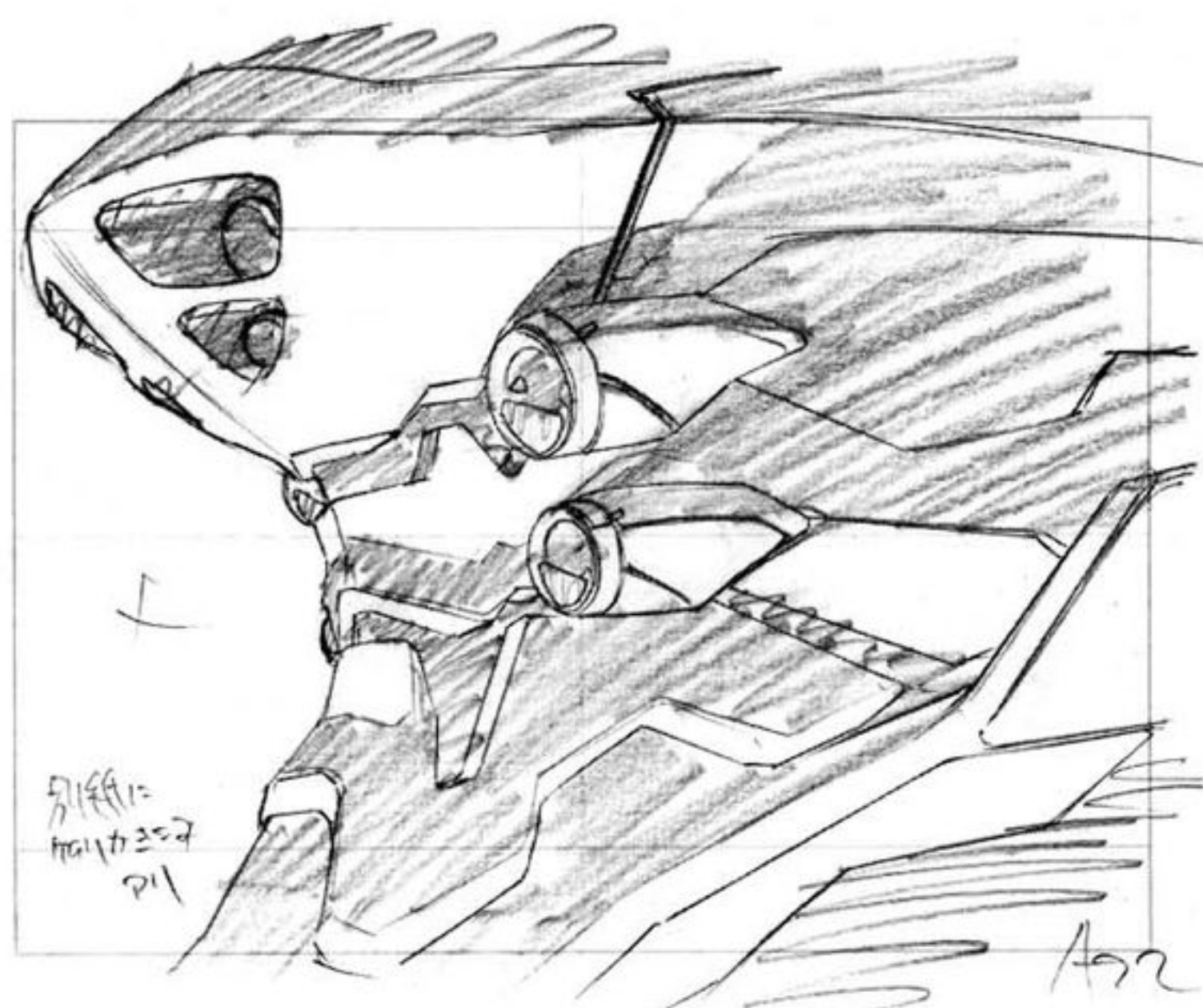
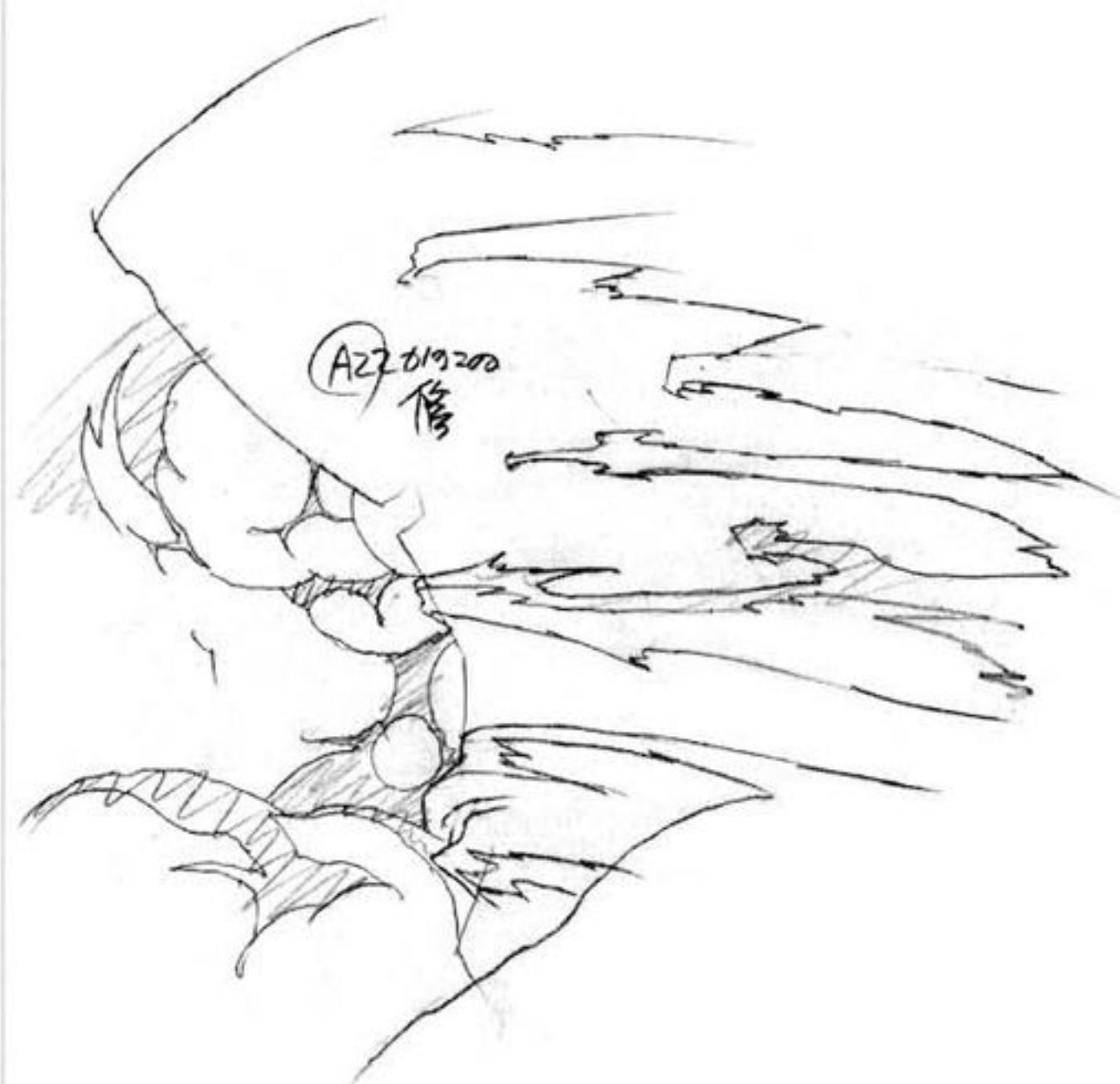

修正原画

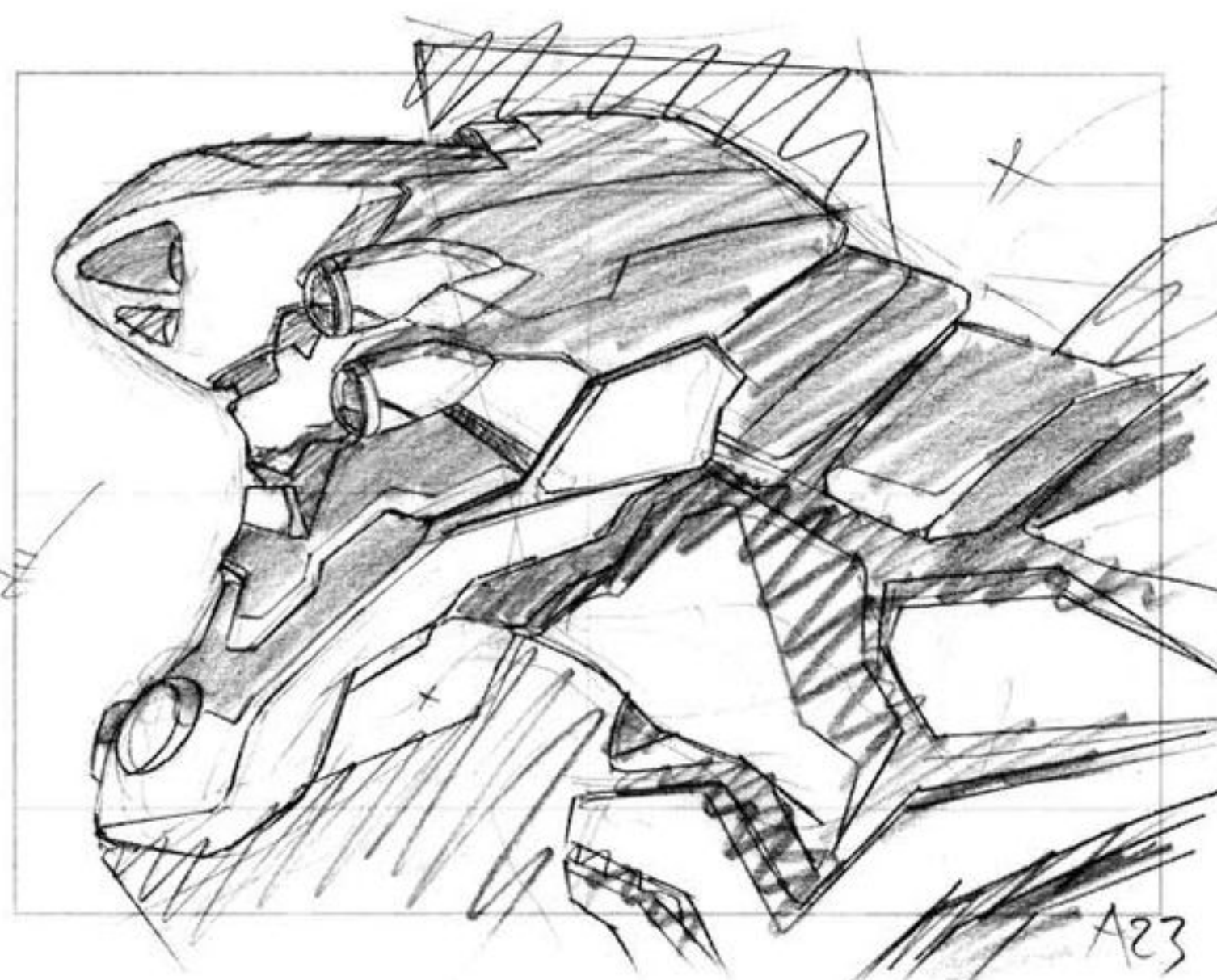



修正原画



修正原画

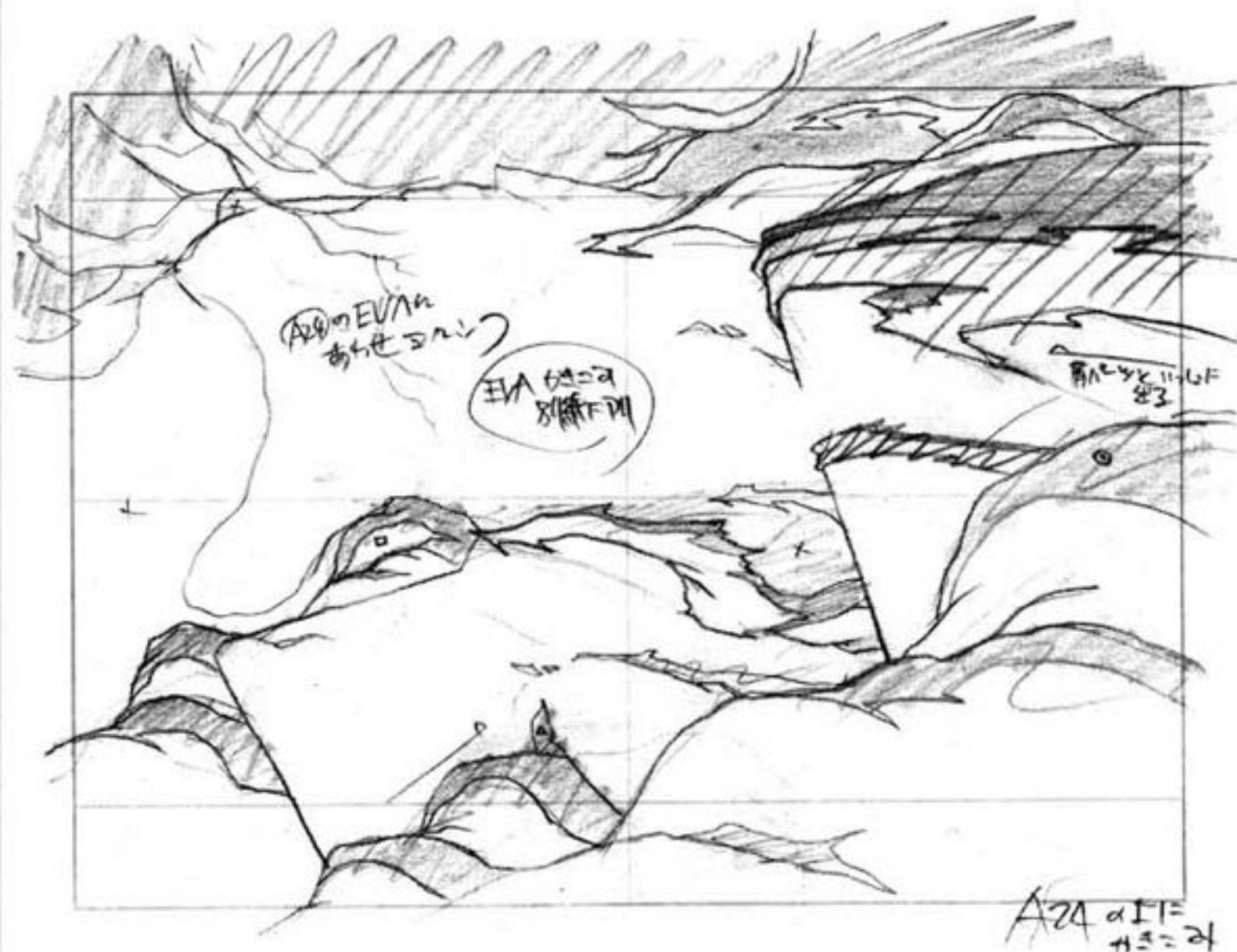
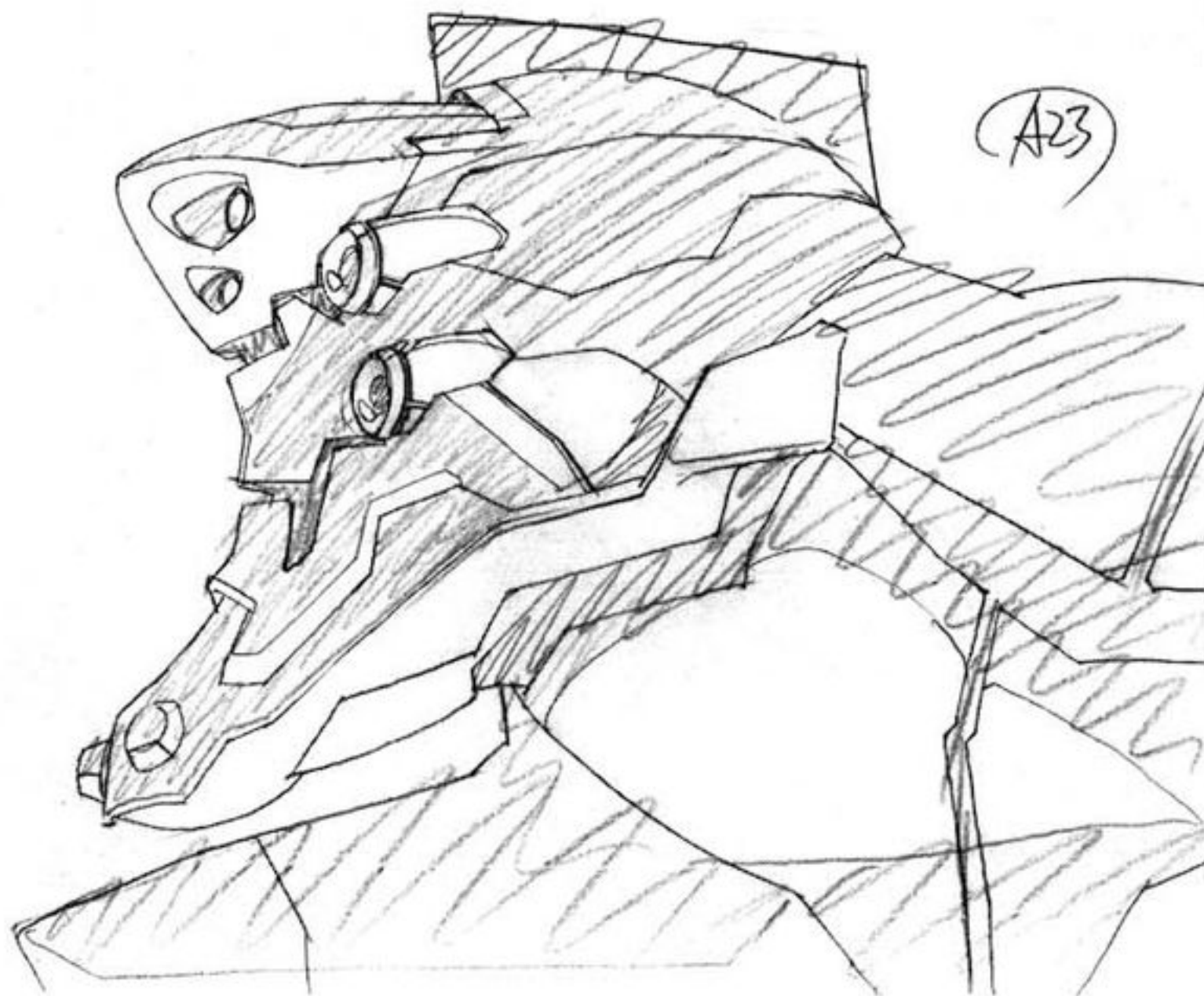

#25-C360

ABC					
EXD					
/	2	32	62	92	
/	4	34	64	94	
/	6	36	66	96	
/	8	38	68	98	
2	10	40	70	100	
2	12	42	72	102	
2	14	44	74		
2	16	46	76		
2	18	48	78		
2	20	50	80		
2	22	52	82		
2	24	54	84		
2	26	56	86		
2	28	58	88		
2	30	60	90		

タイムシート

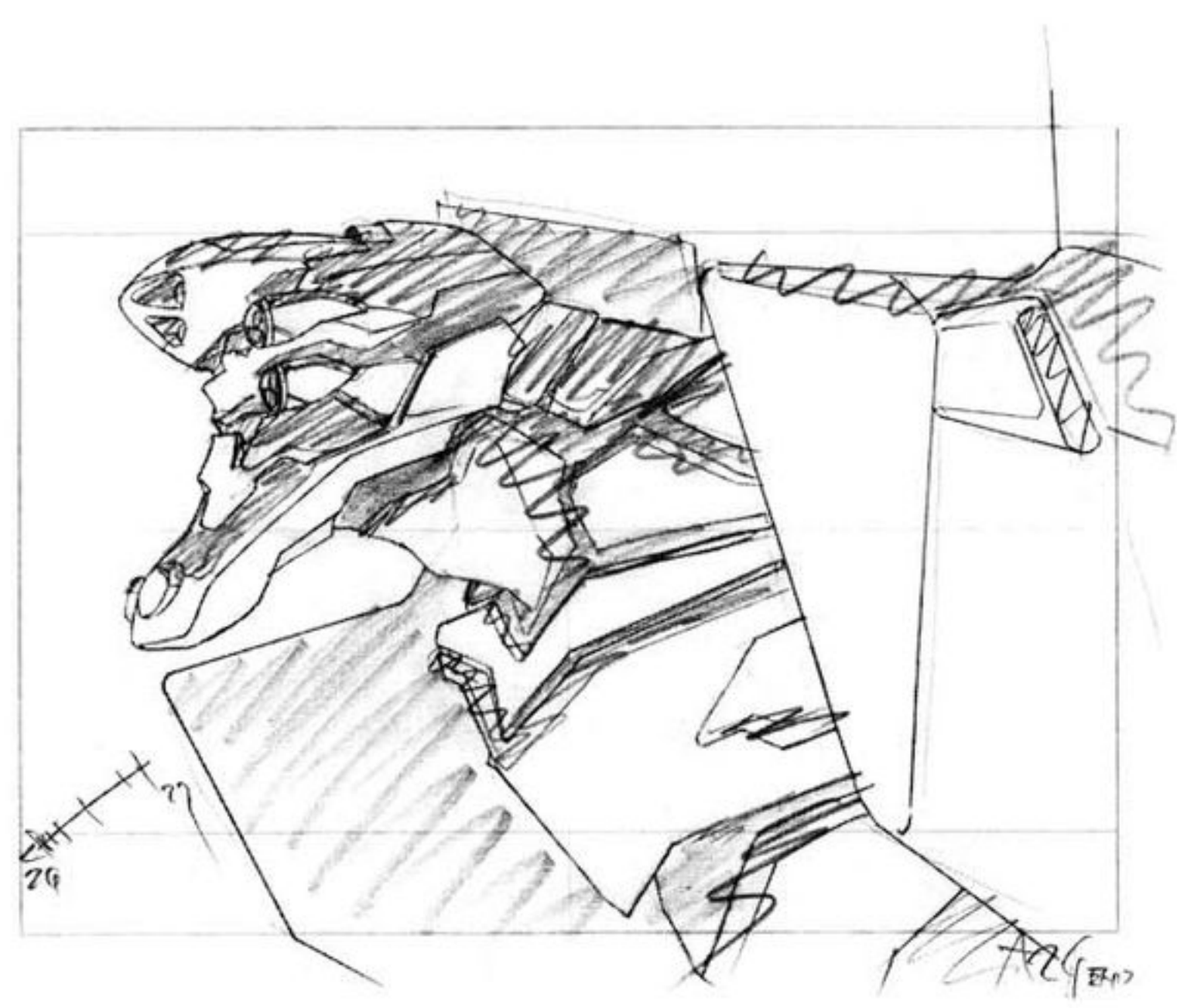





#25-C374

修正原画





修正原画

B34



修正原画

B24

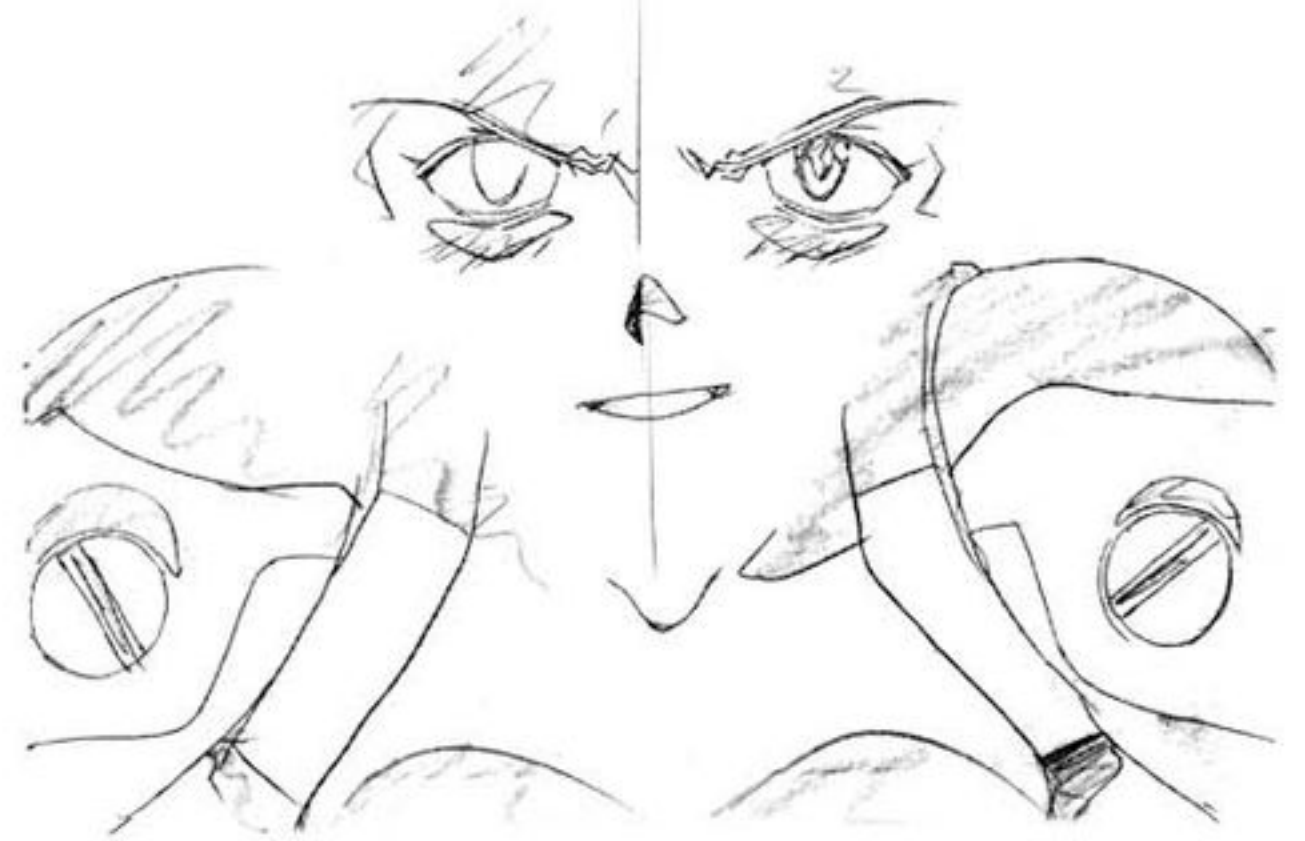



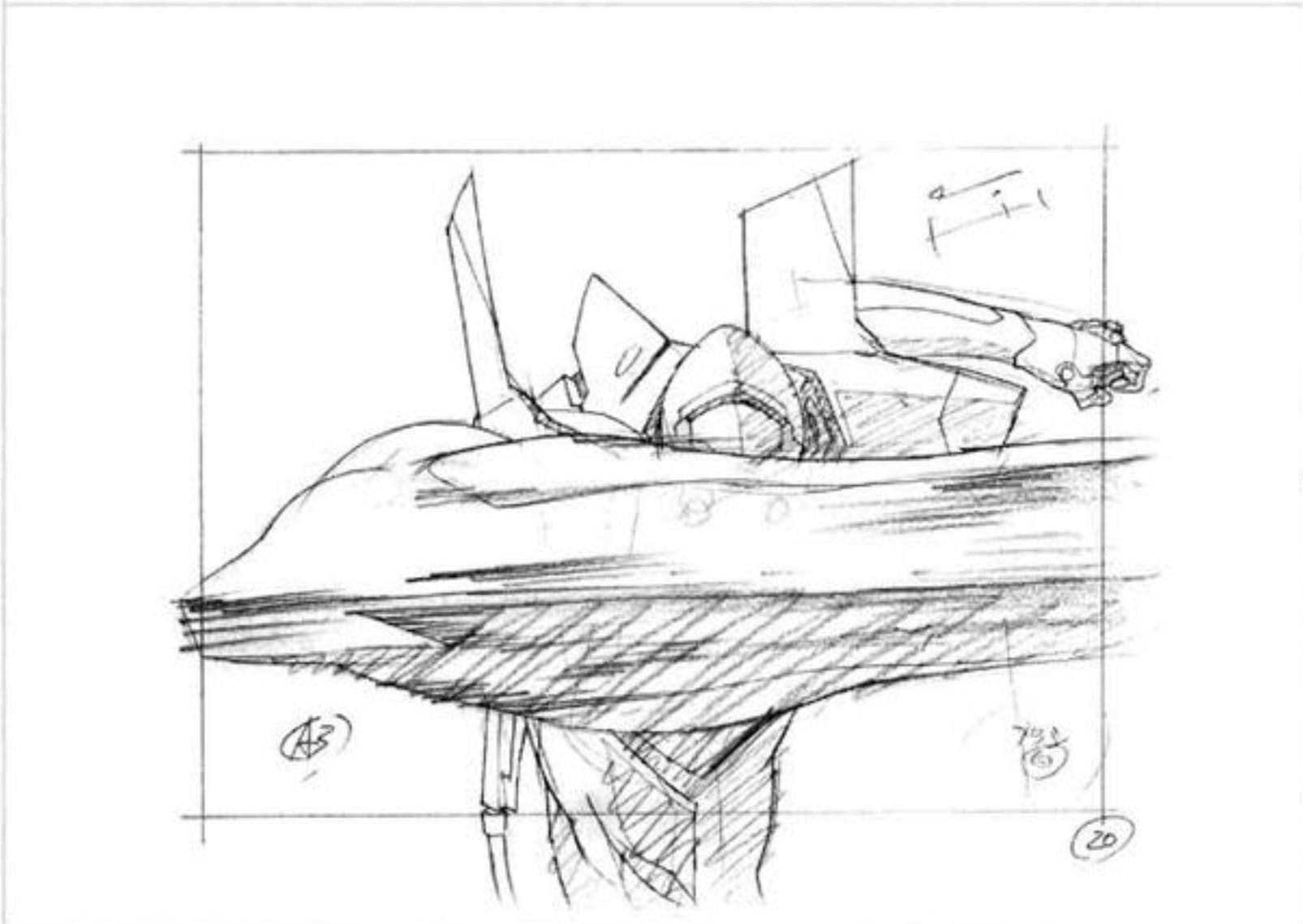
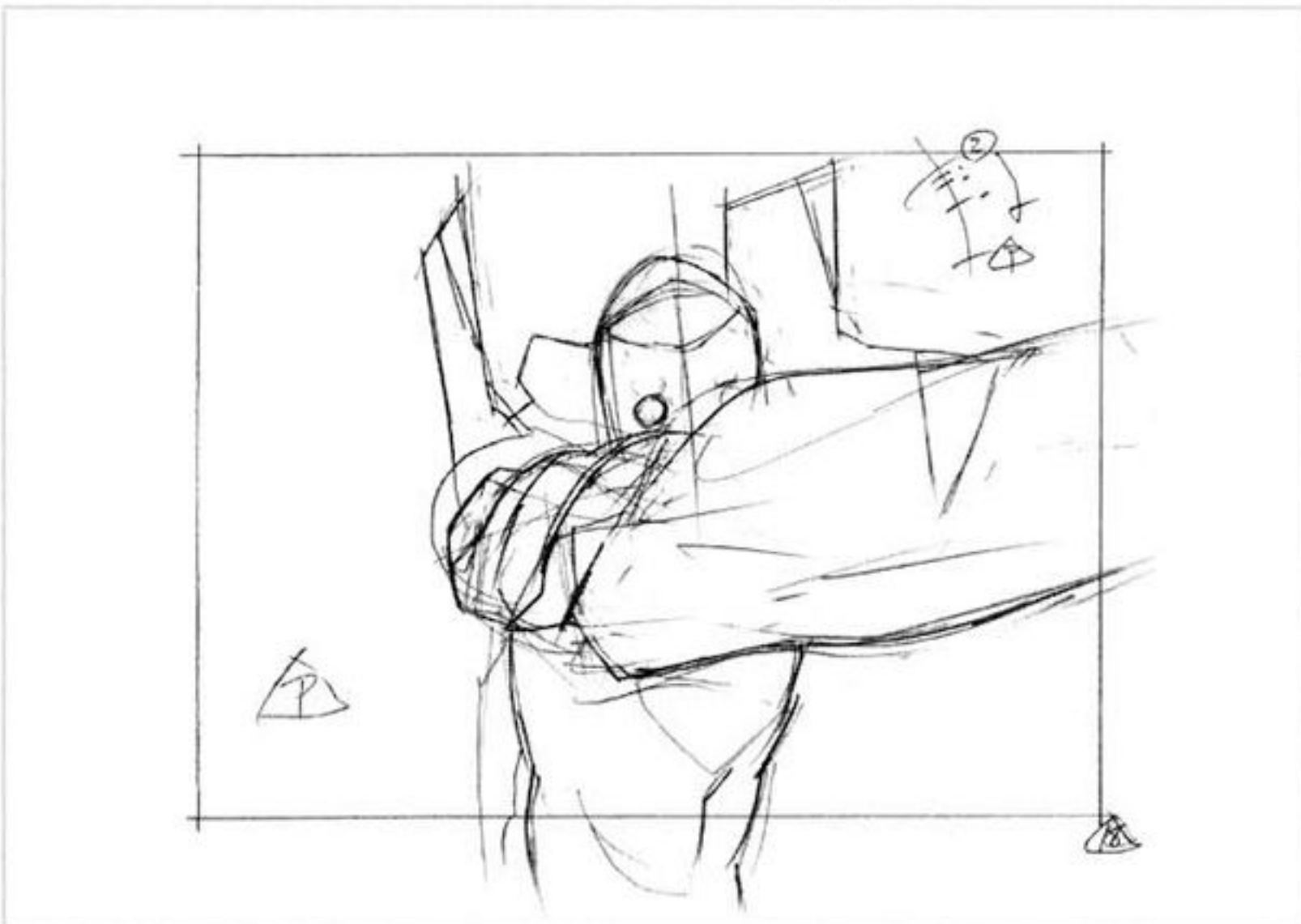



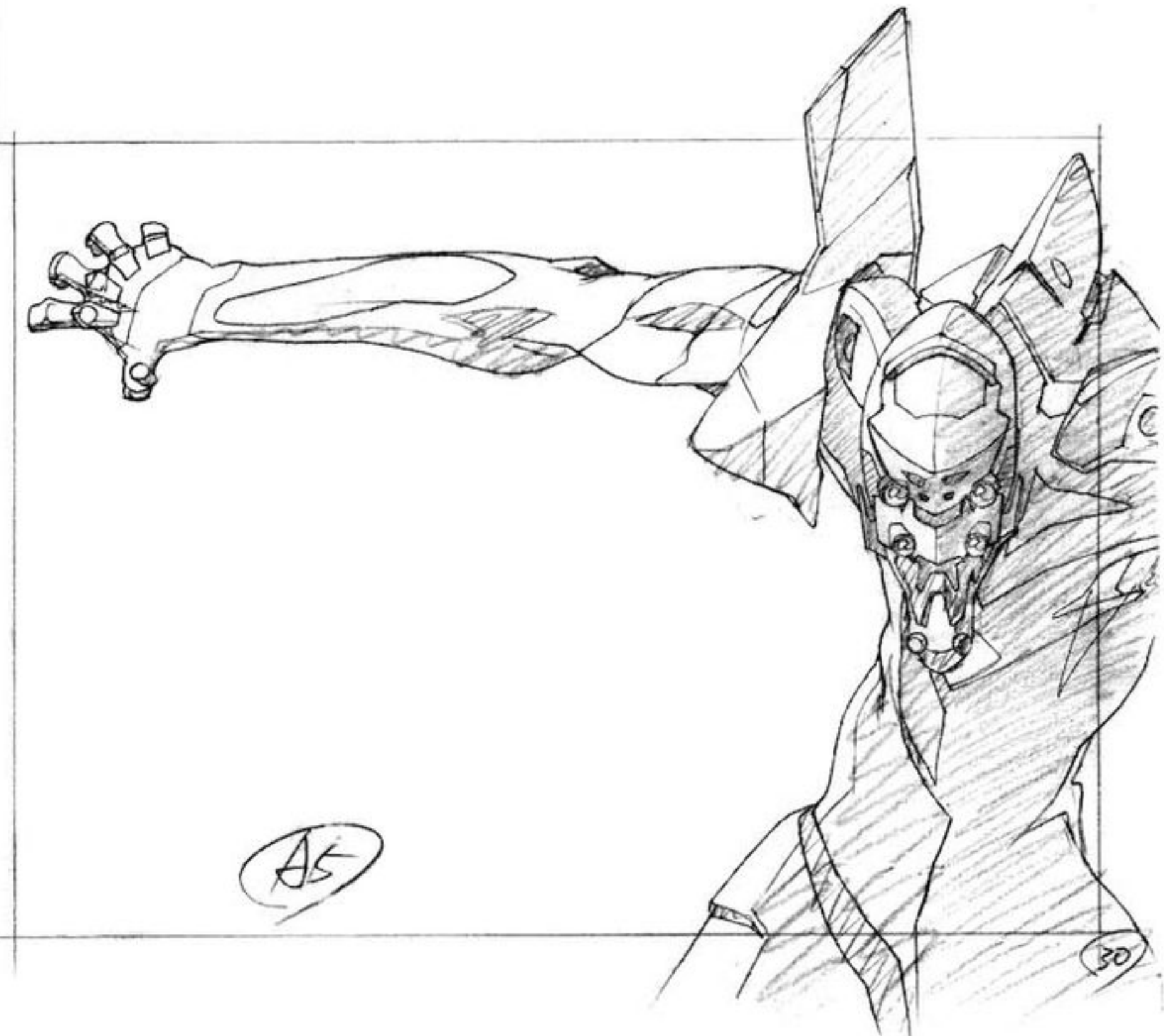
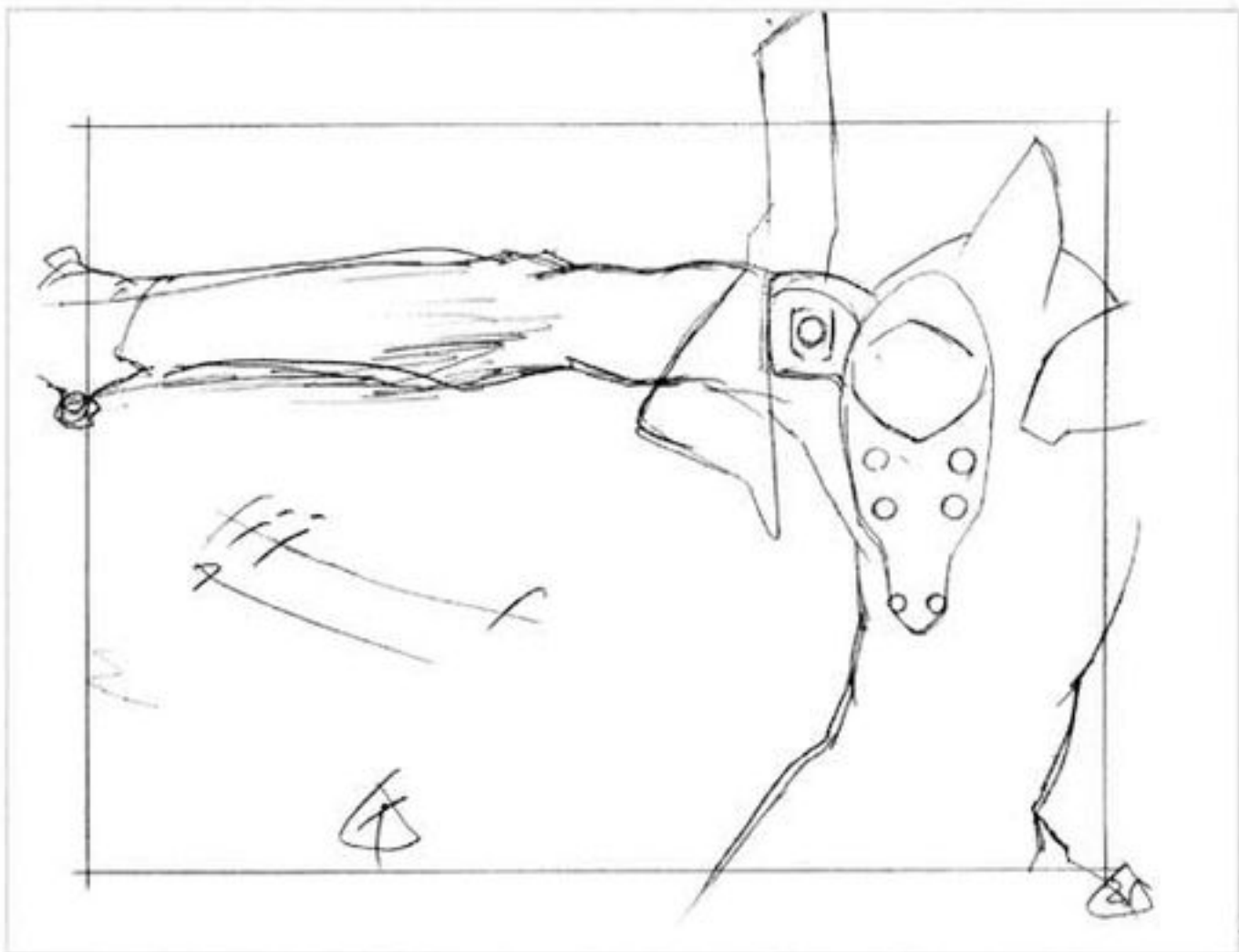
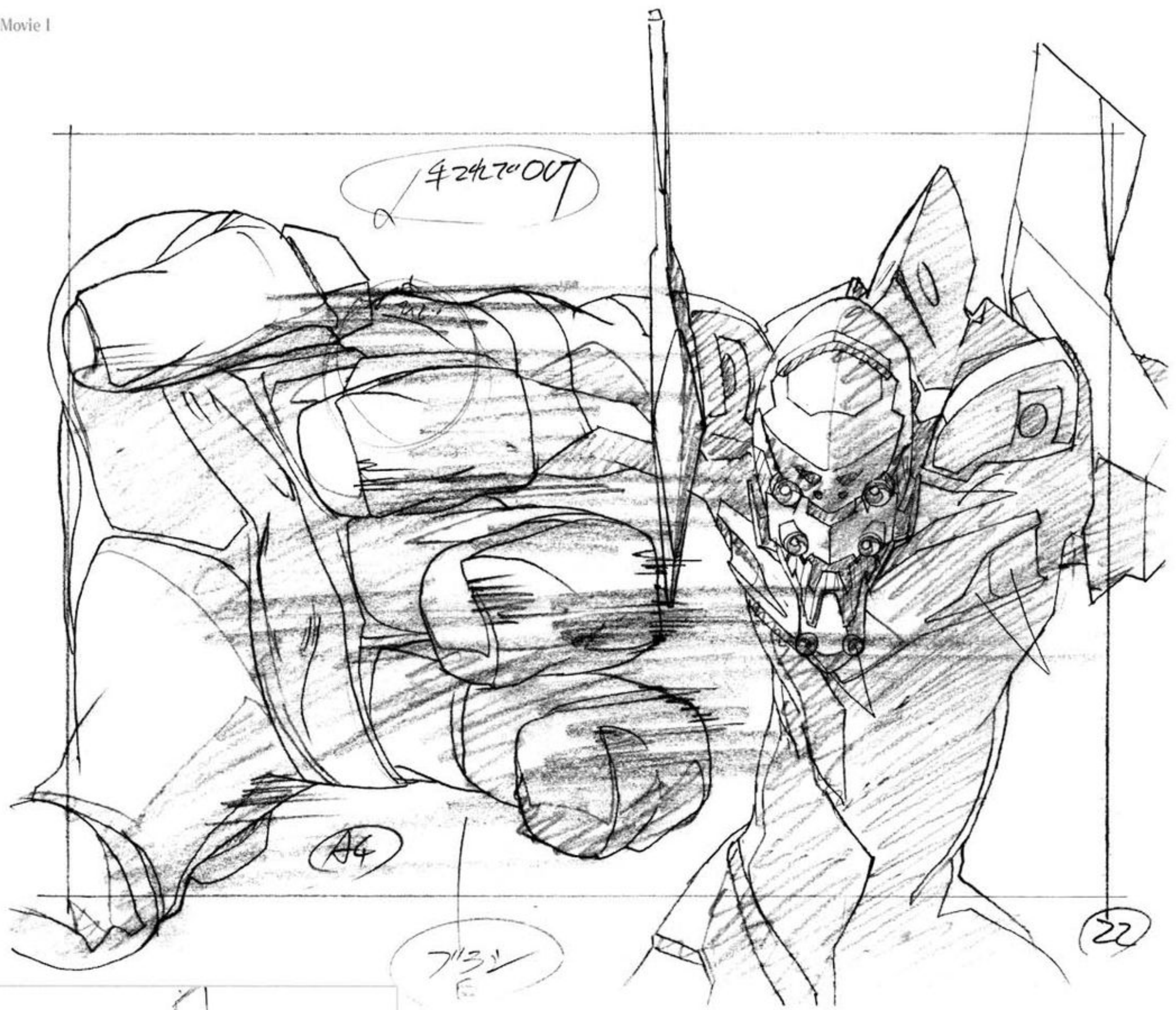

1	
2	
3	
4	
5	
6	
7	
8	
9	
10	
11	
12	
13	
14	
15	
16	
17	
18	
19	
20	
21	
22	
23	
24	

26	
27	
28	
29	
30	
31	
32	

タイムシート





修正原画

修正原画



#25-C383



修正原画

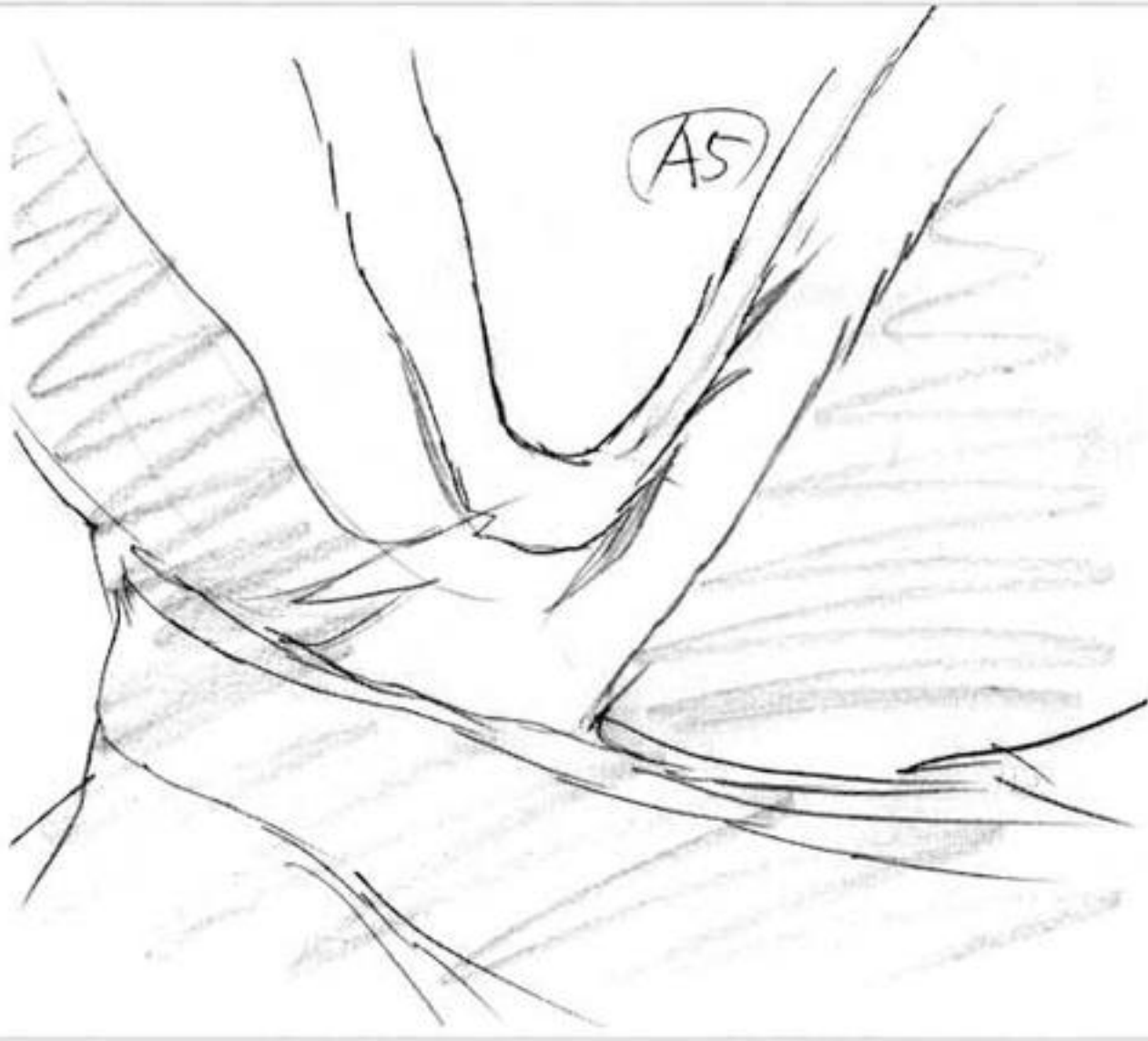

修正原画

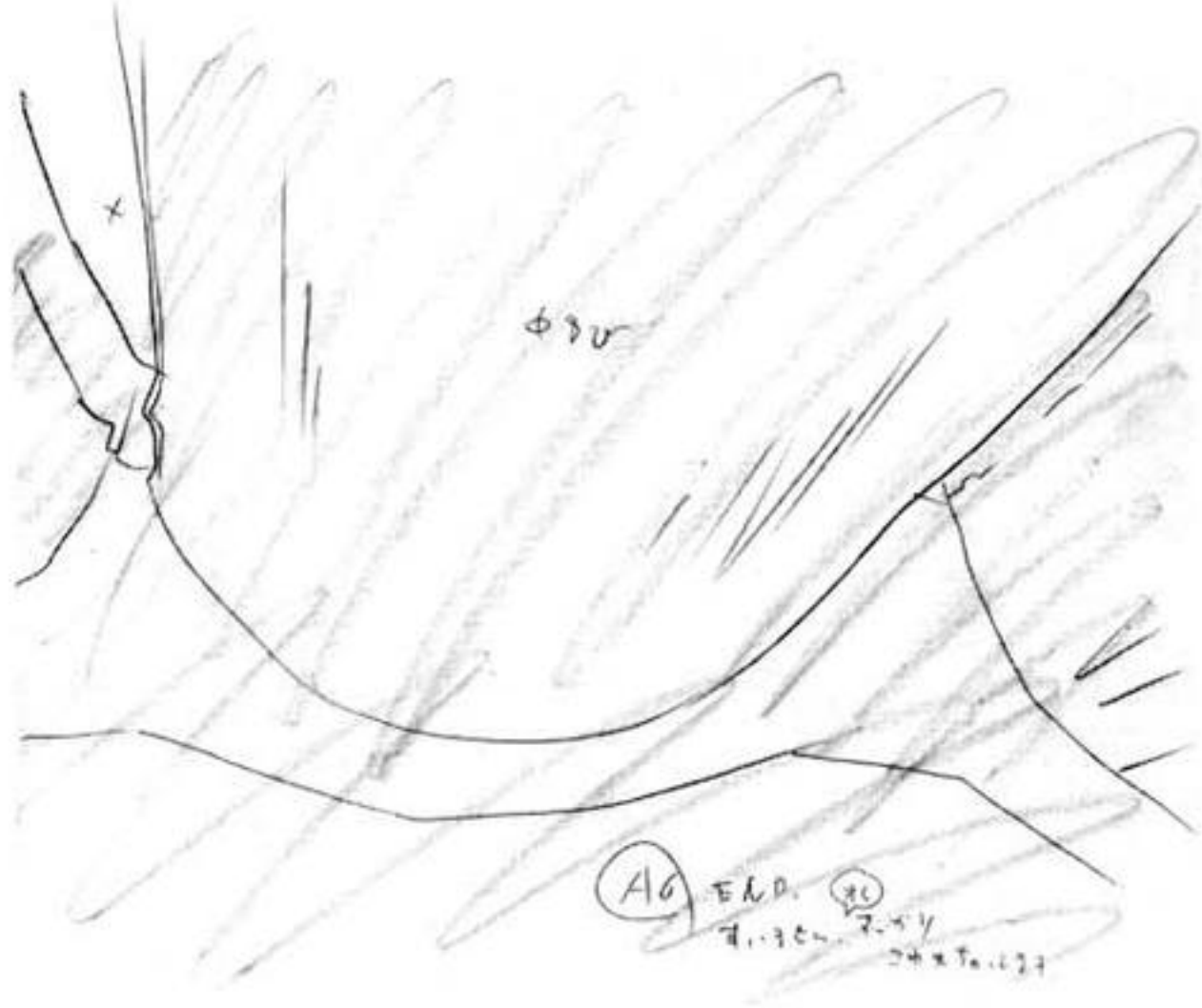
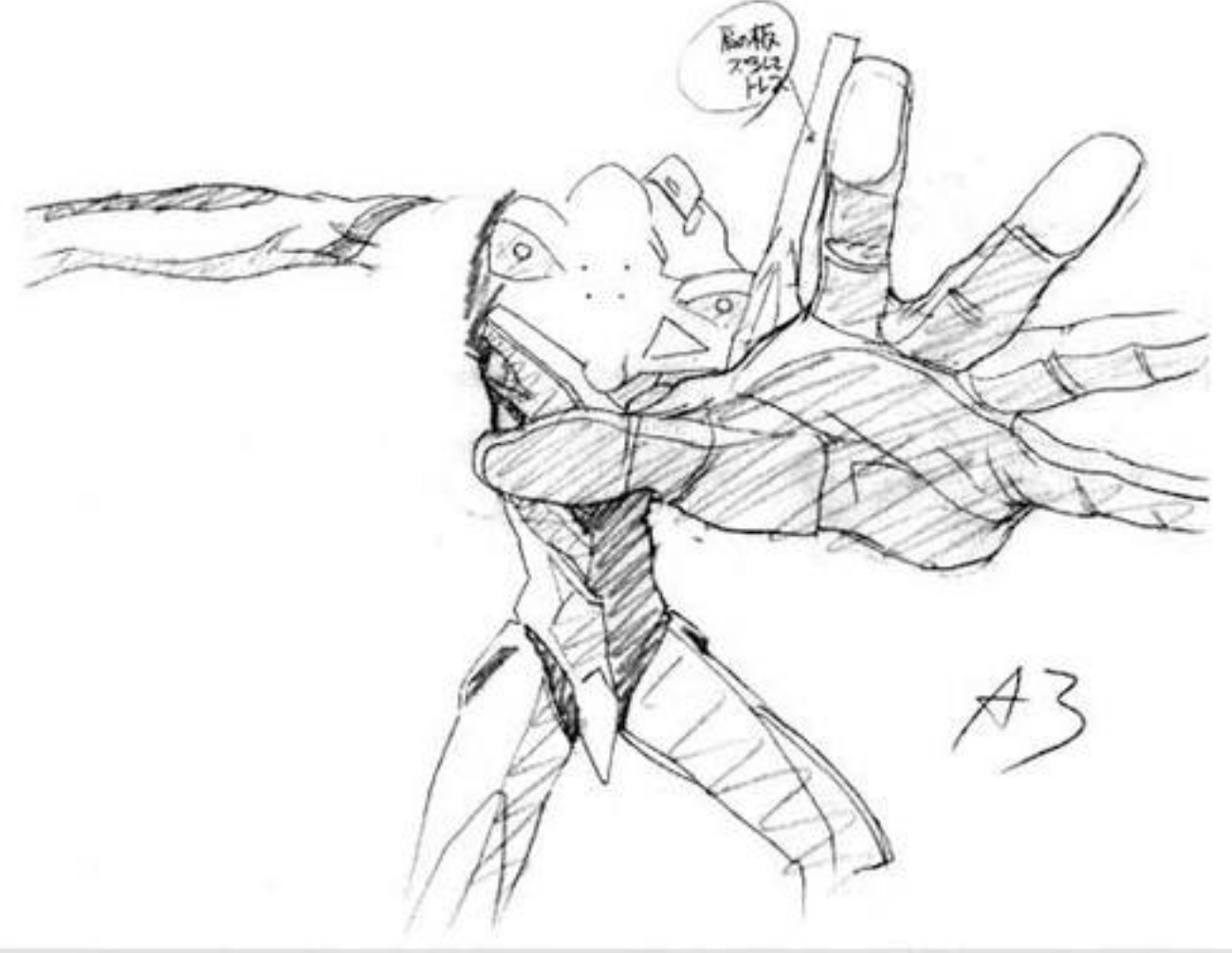

修正原画

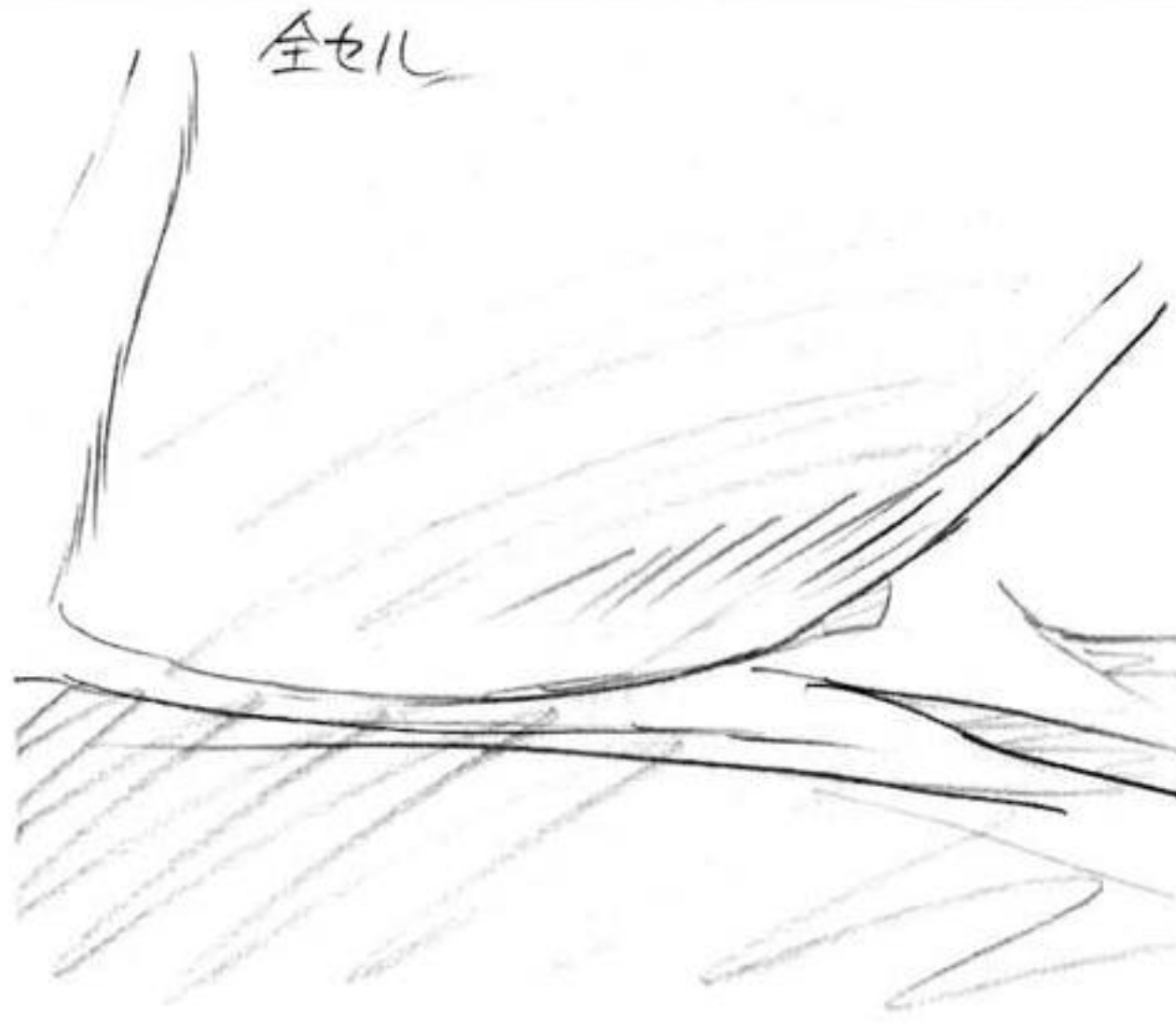

修正原画



タイムシート

①	2
・	4
・	6
・	8
・	10
②	12
・	14
・	16
・	18
③	20
・	22
4	24
5	
6	

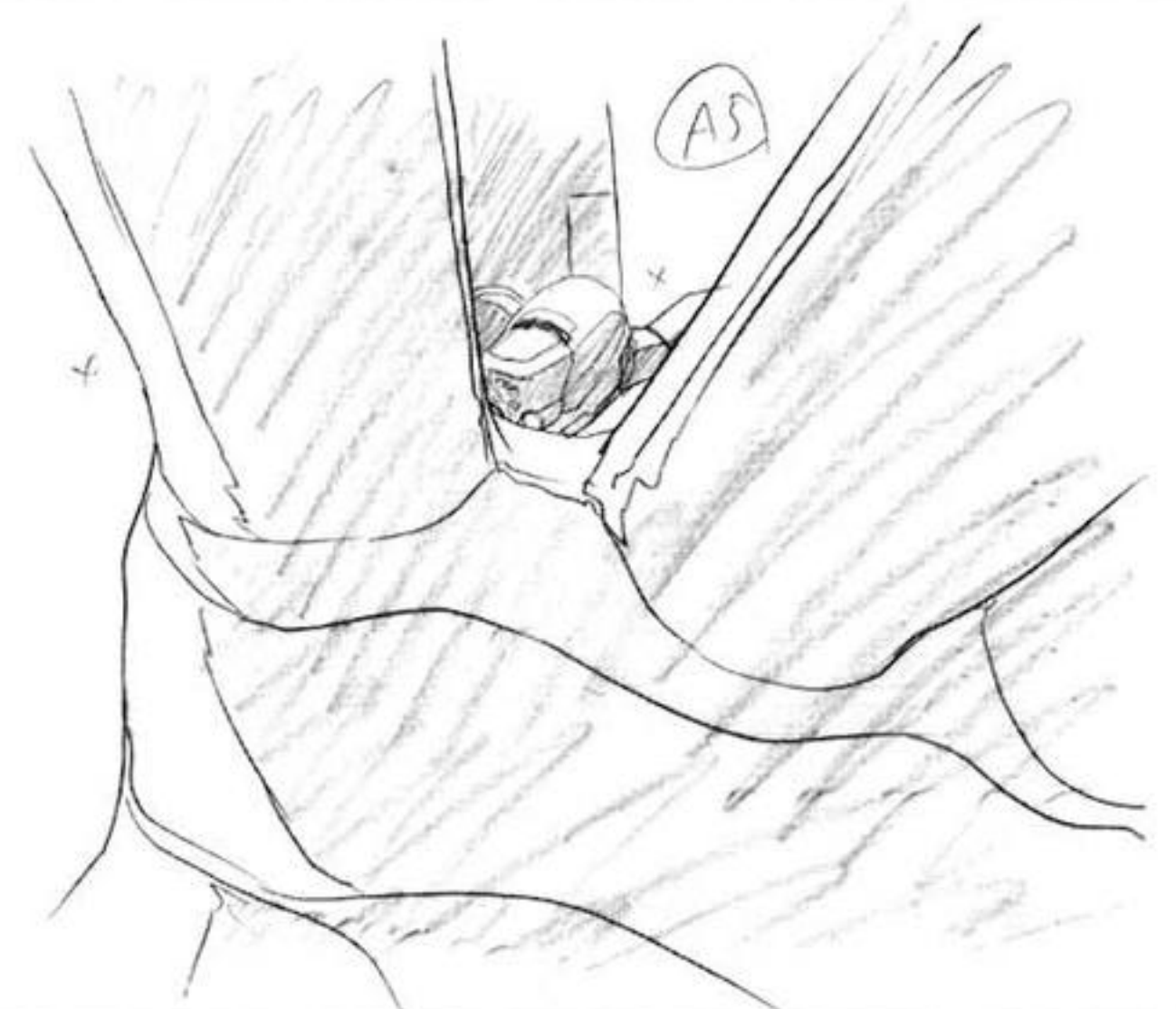



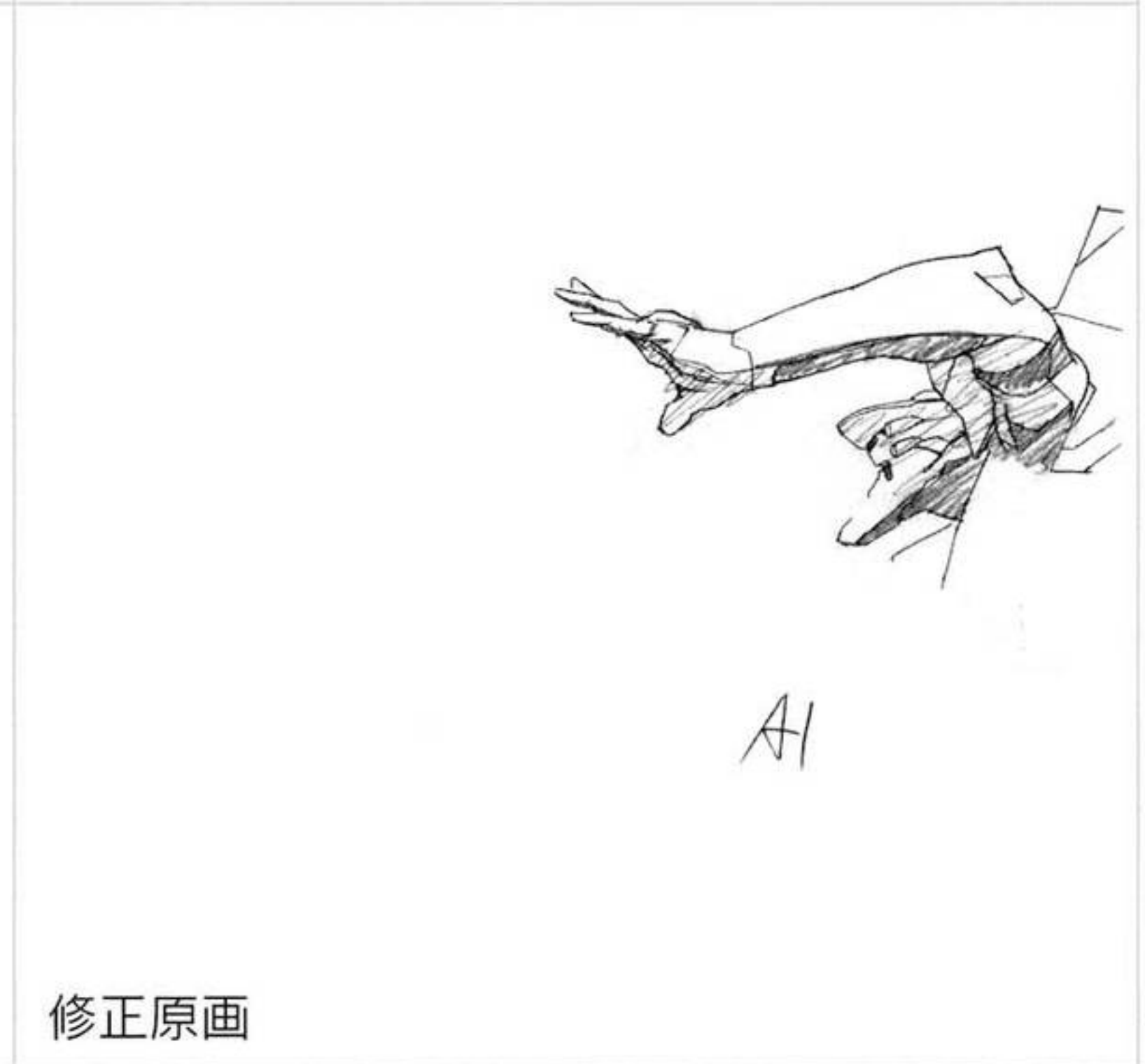
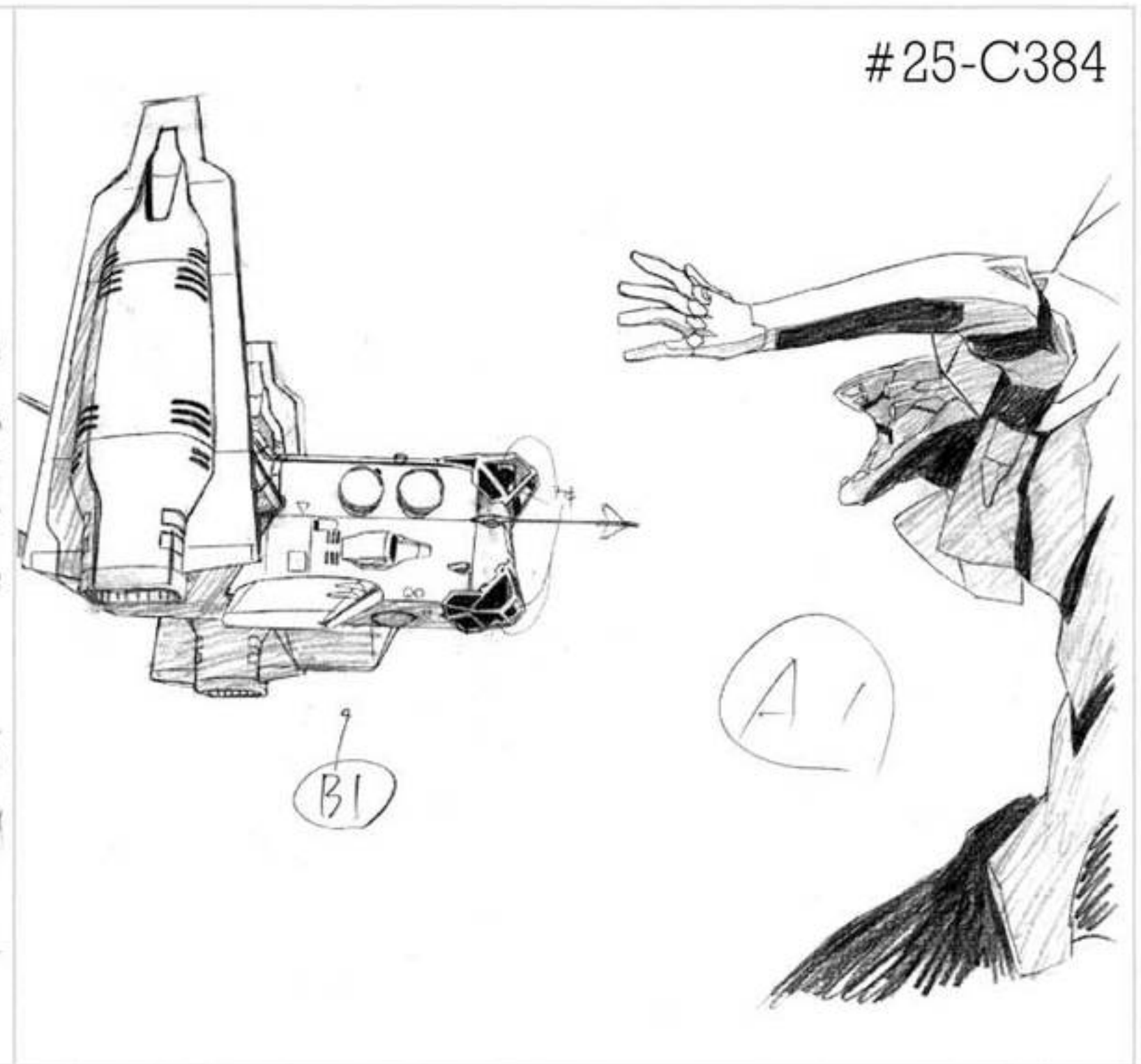
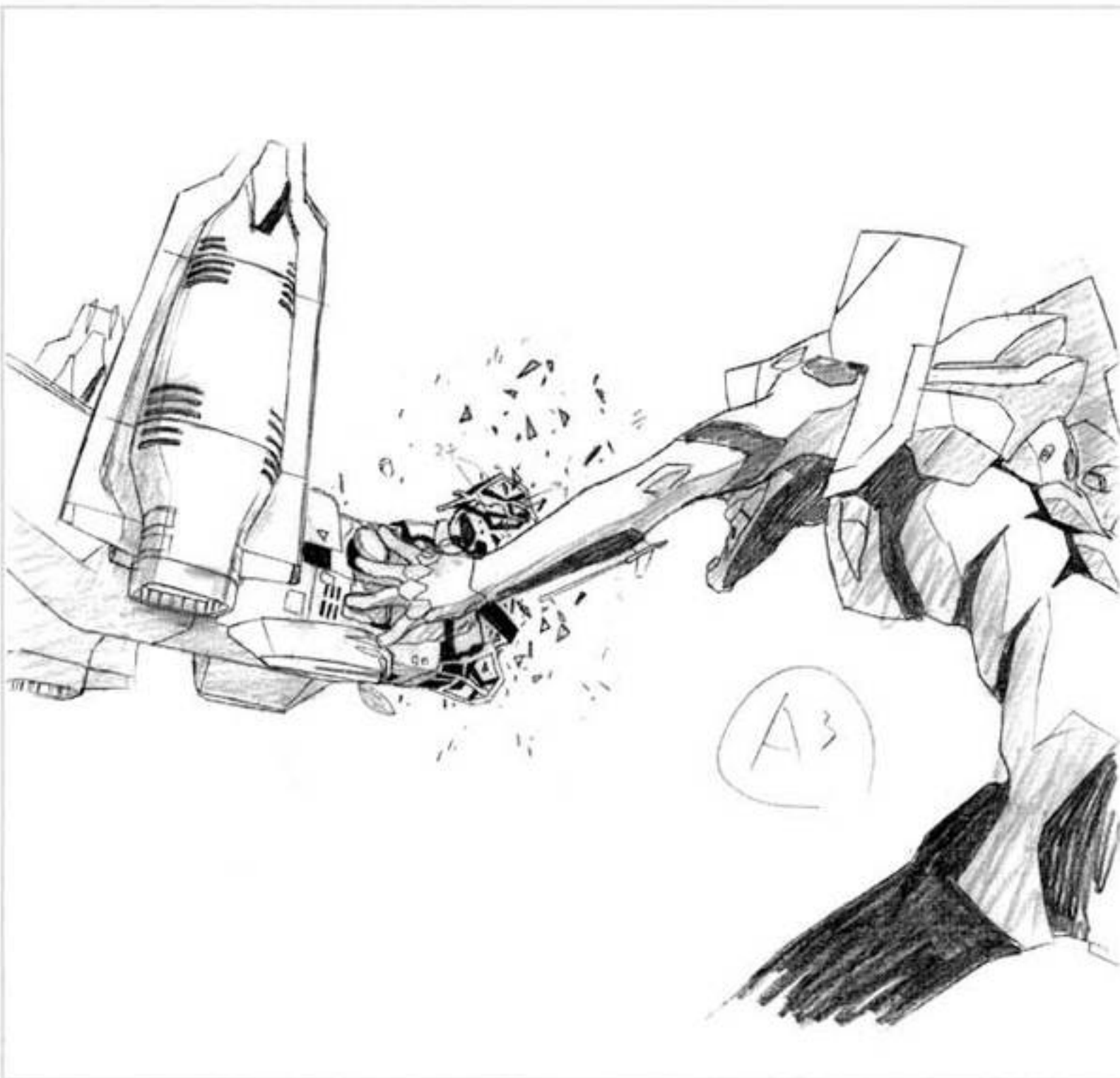

修正原画

修正原画

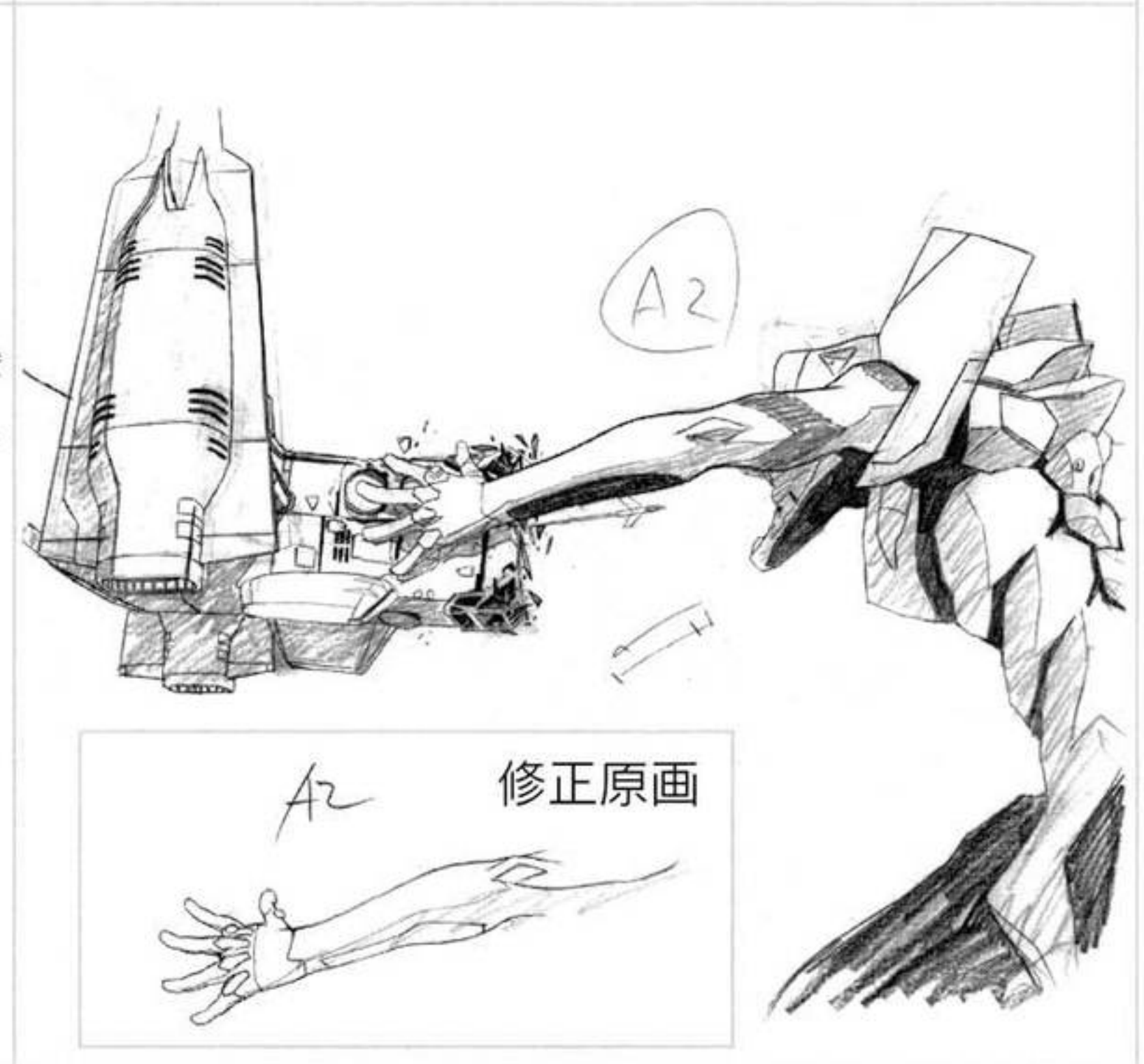
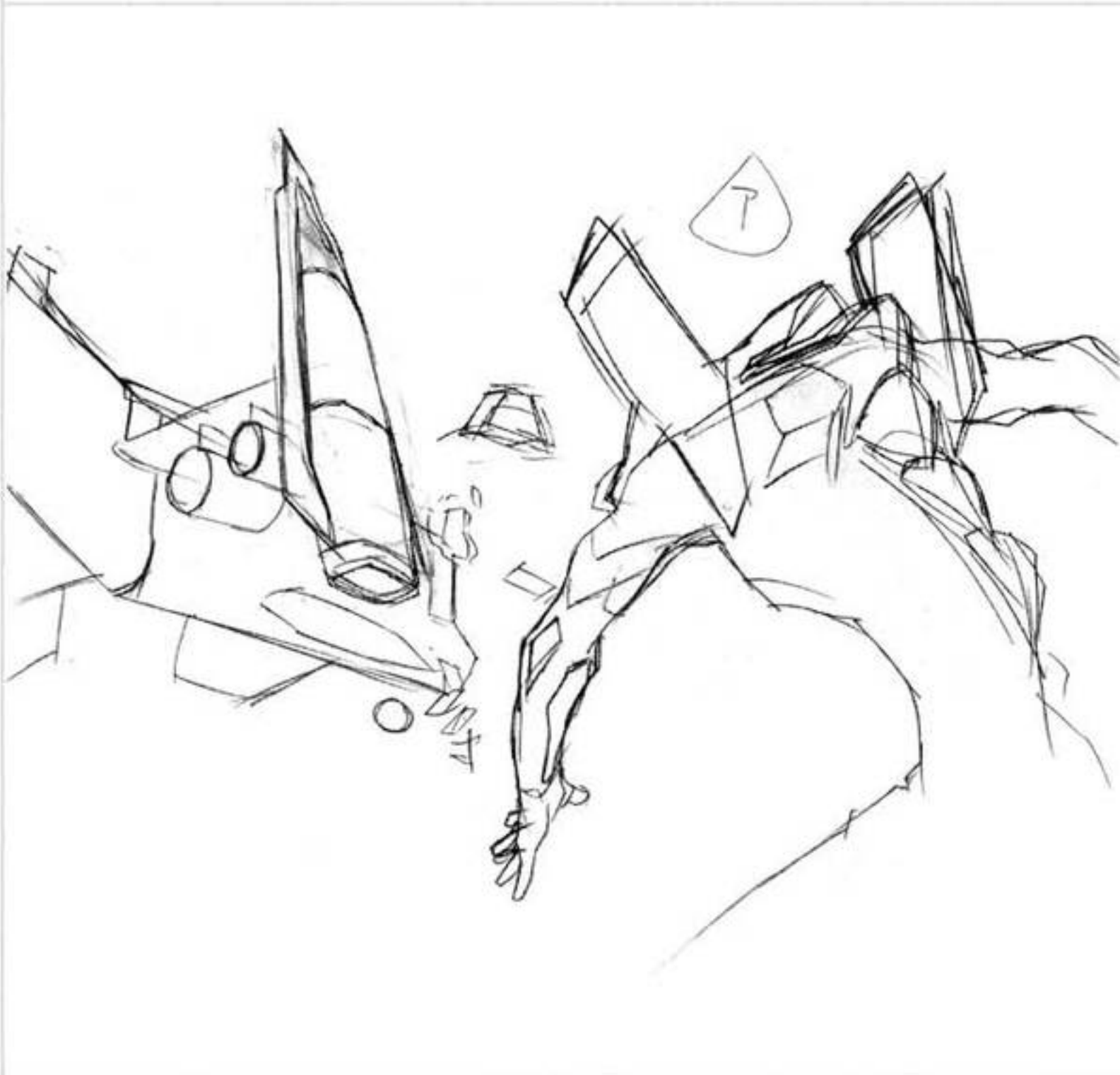

修正原画



A4

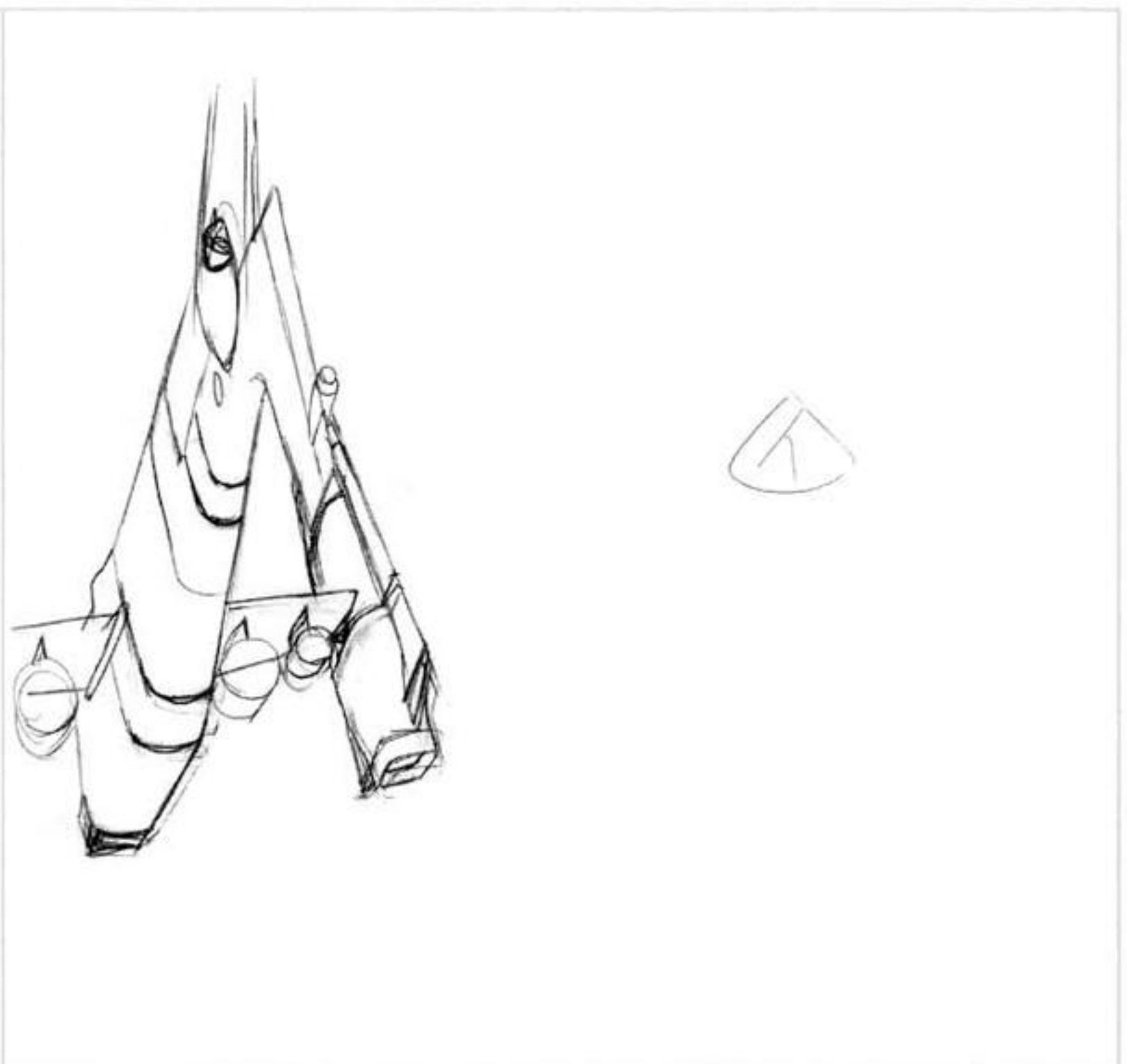
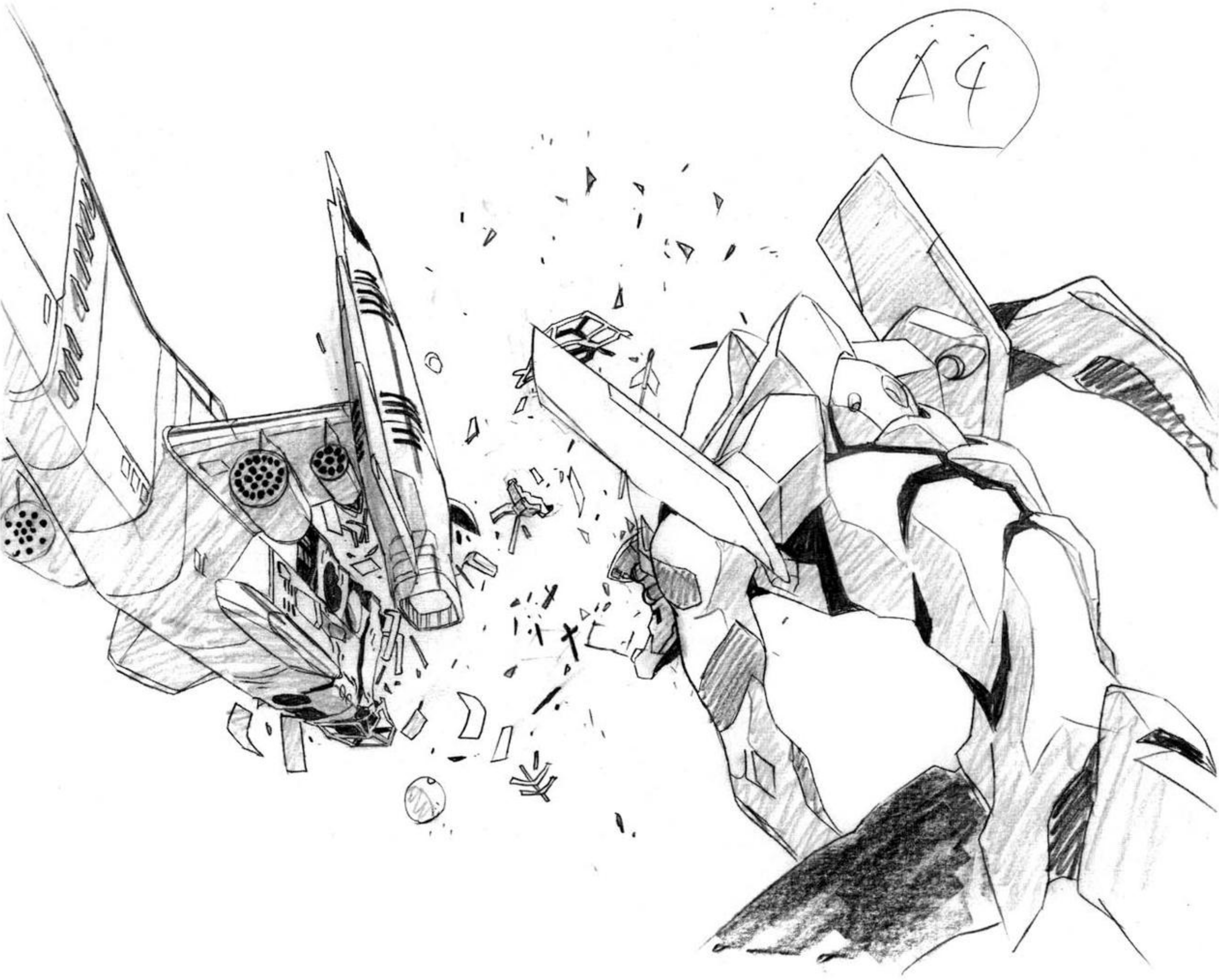



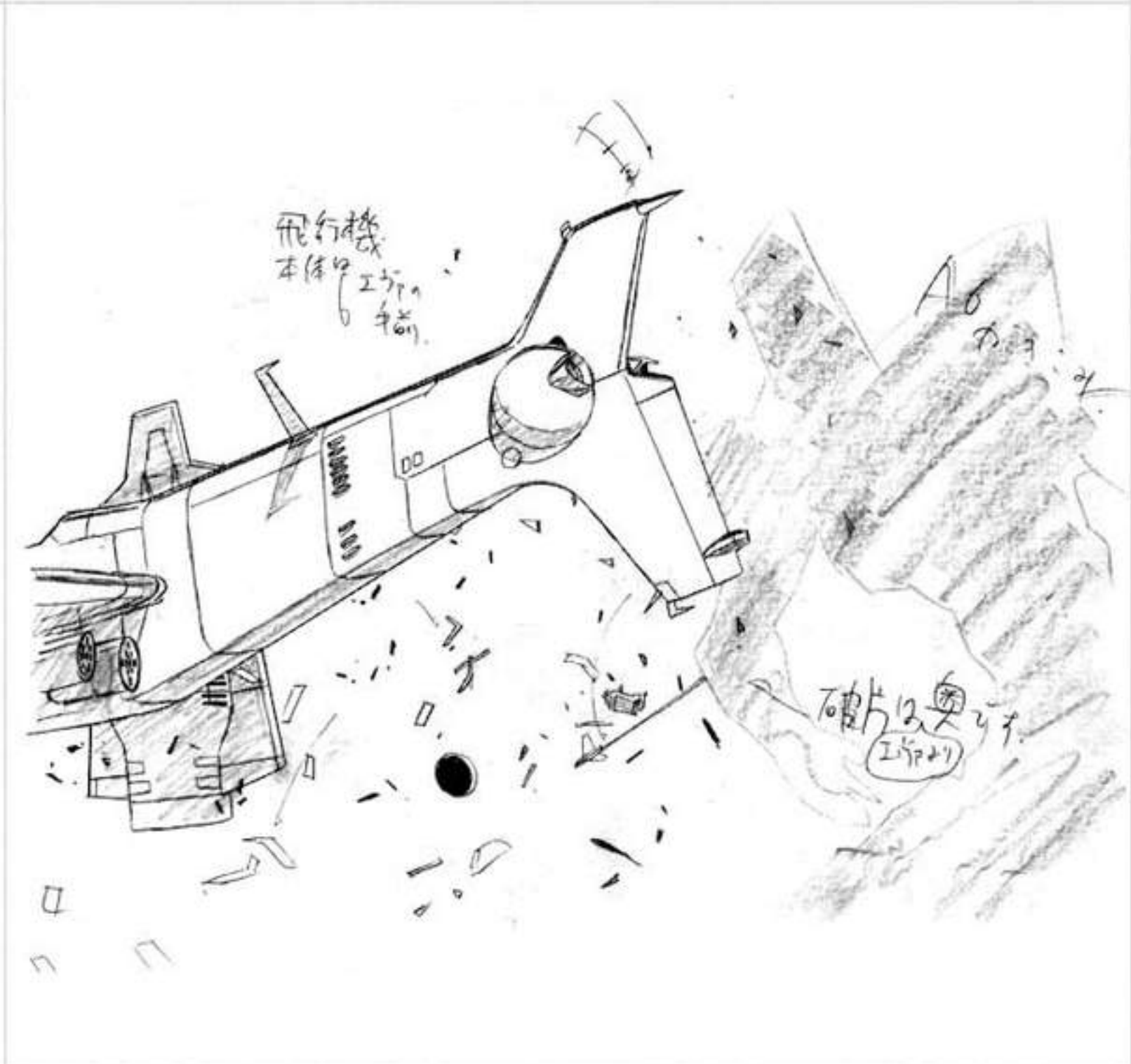
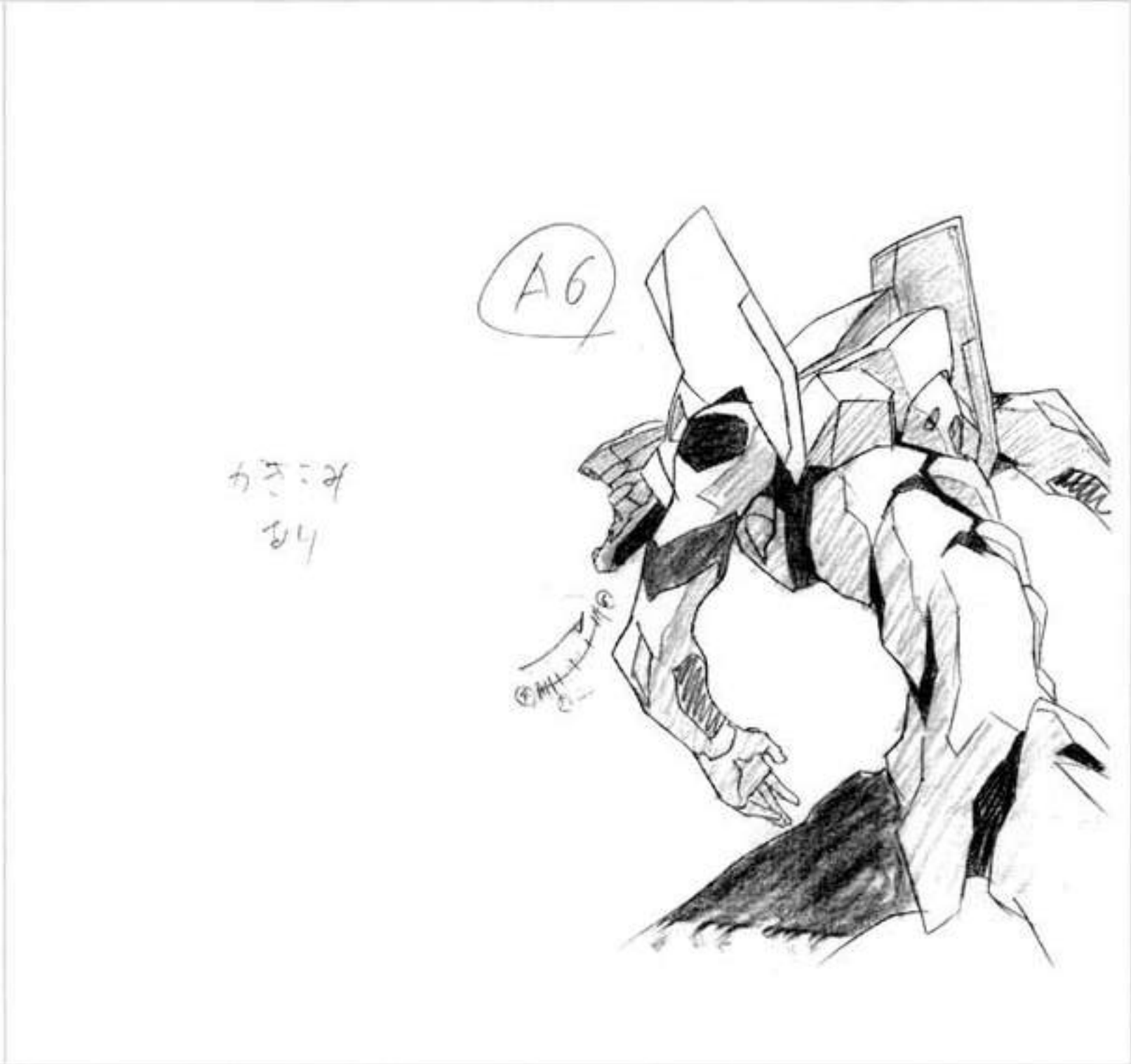



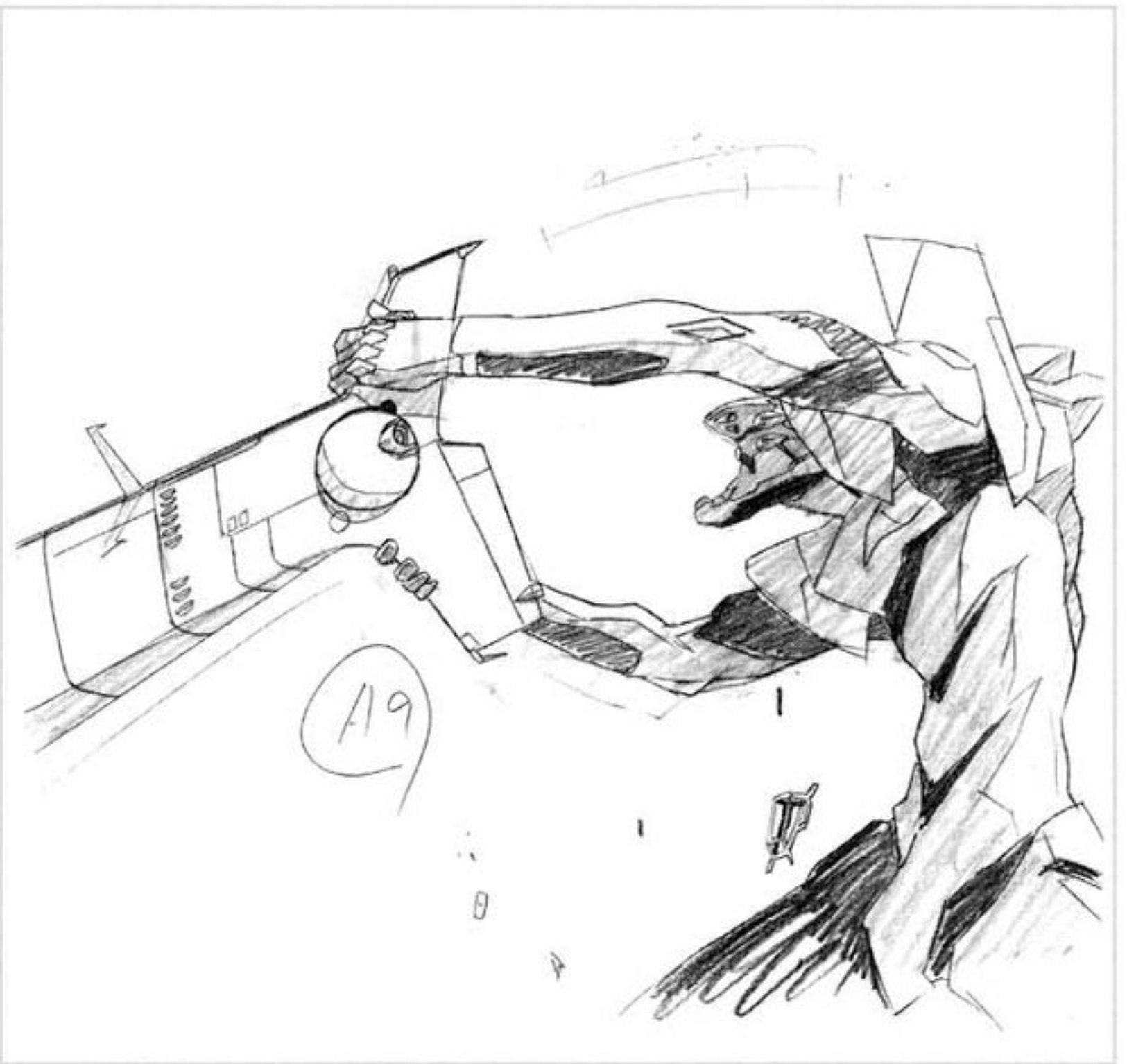
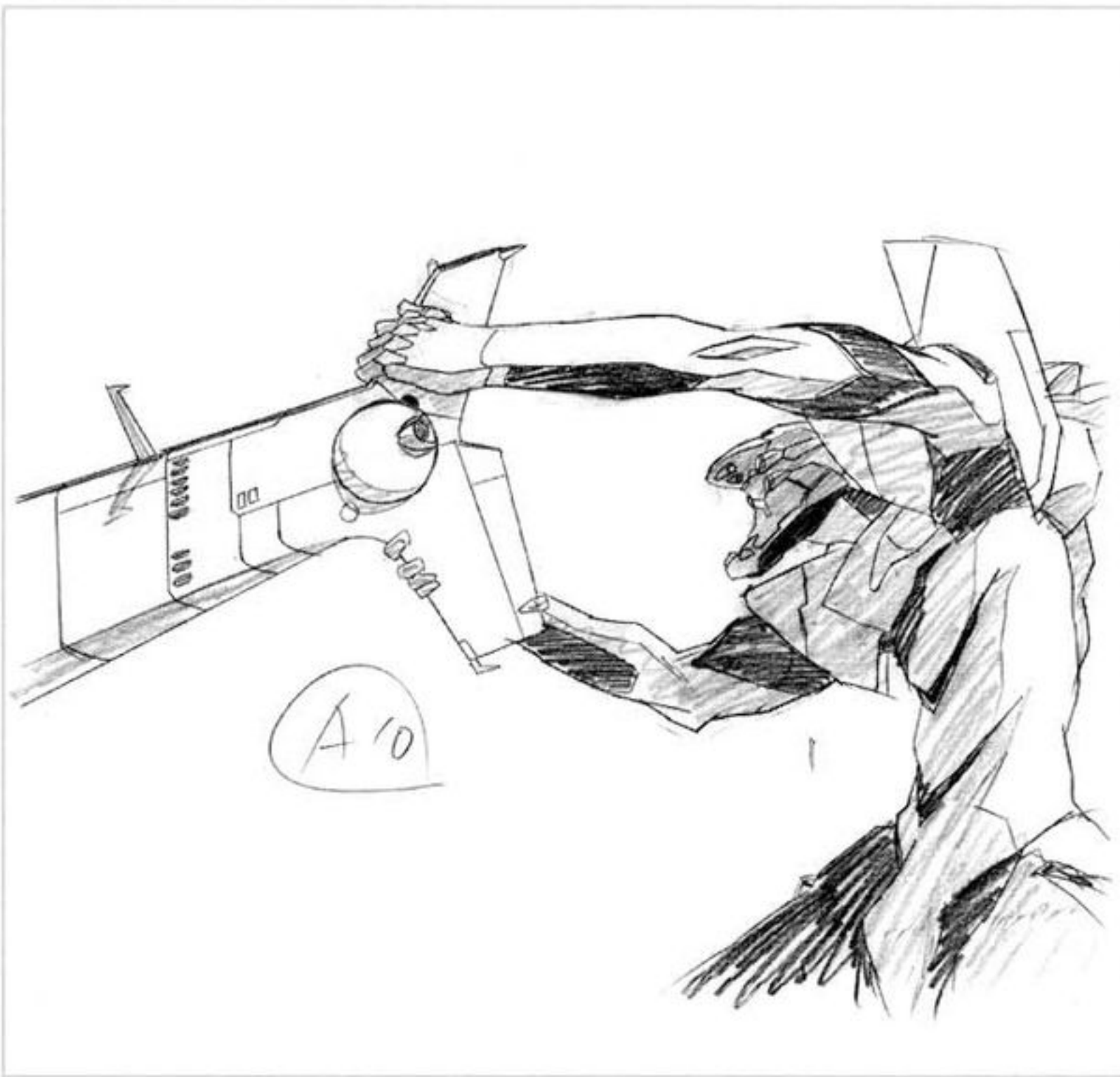

#25-C384

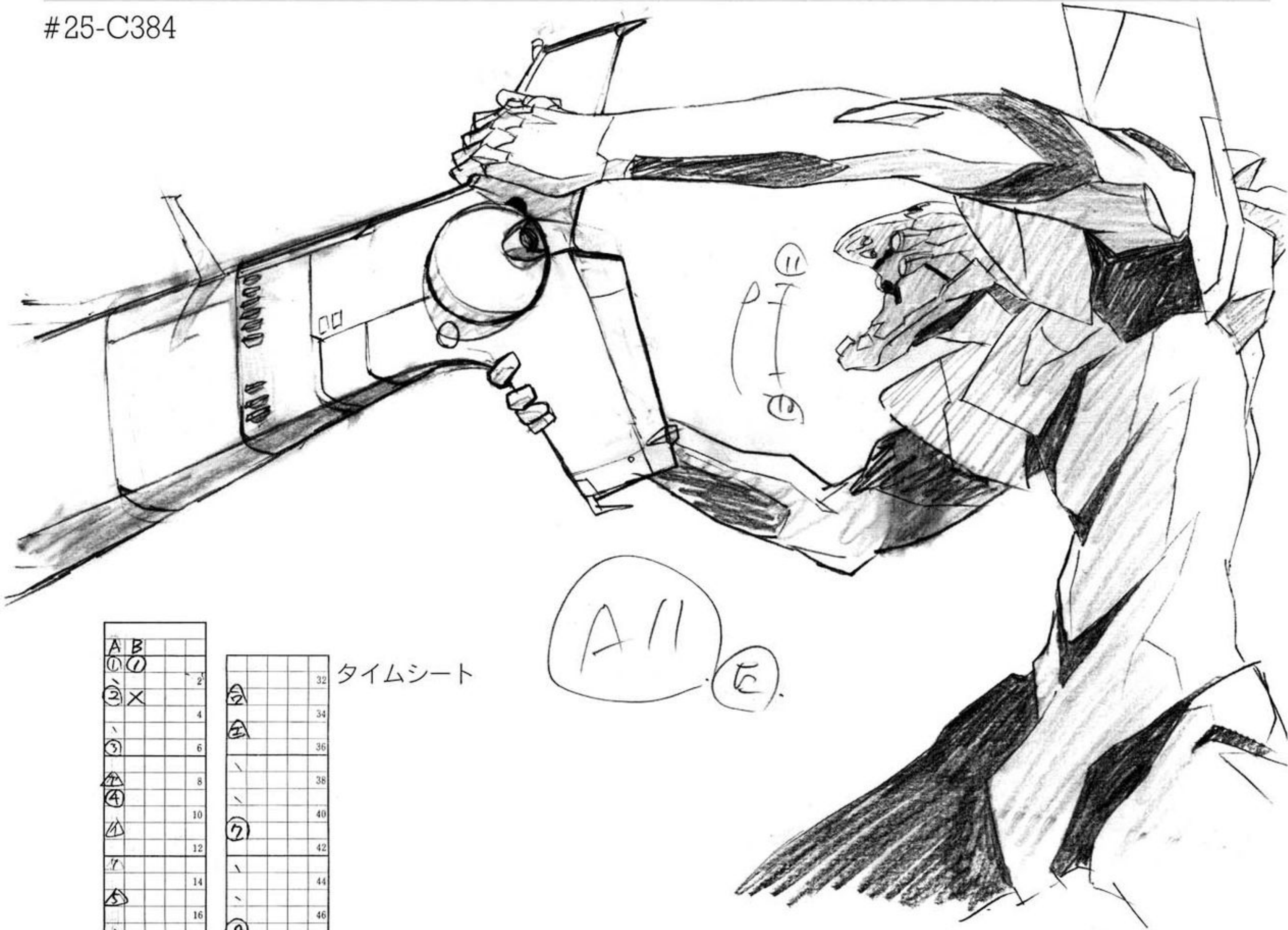

A	B		
①	①		
②	X		2
			4
③			6
④			8
⑤			10
⑥			12
⑦			14
⑧			16
			18
			20
⑨			22
⑩			24
			26
⑪			28
			30

タイムシート

			32
			34
			36
			38
			40
⑫			42
			44
			46
⑬			48
			50
⑭			52
⑮			54
			56
			58
⑯			60

A11 (E)



(21)

(D1)

(B1)

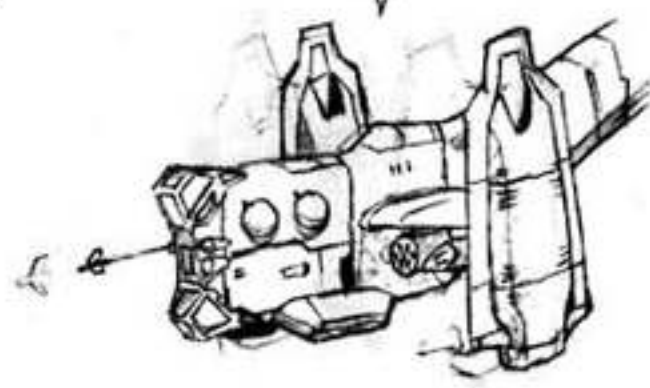
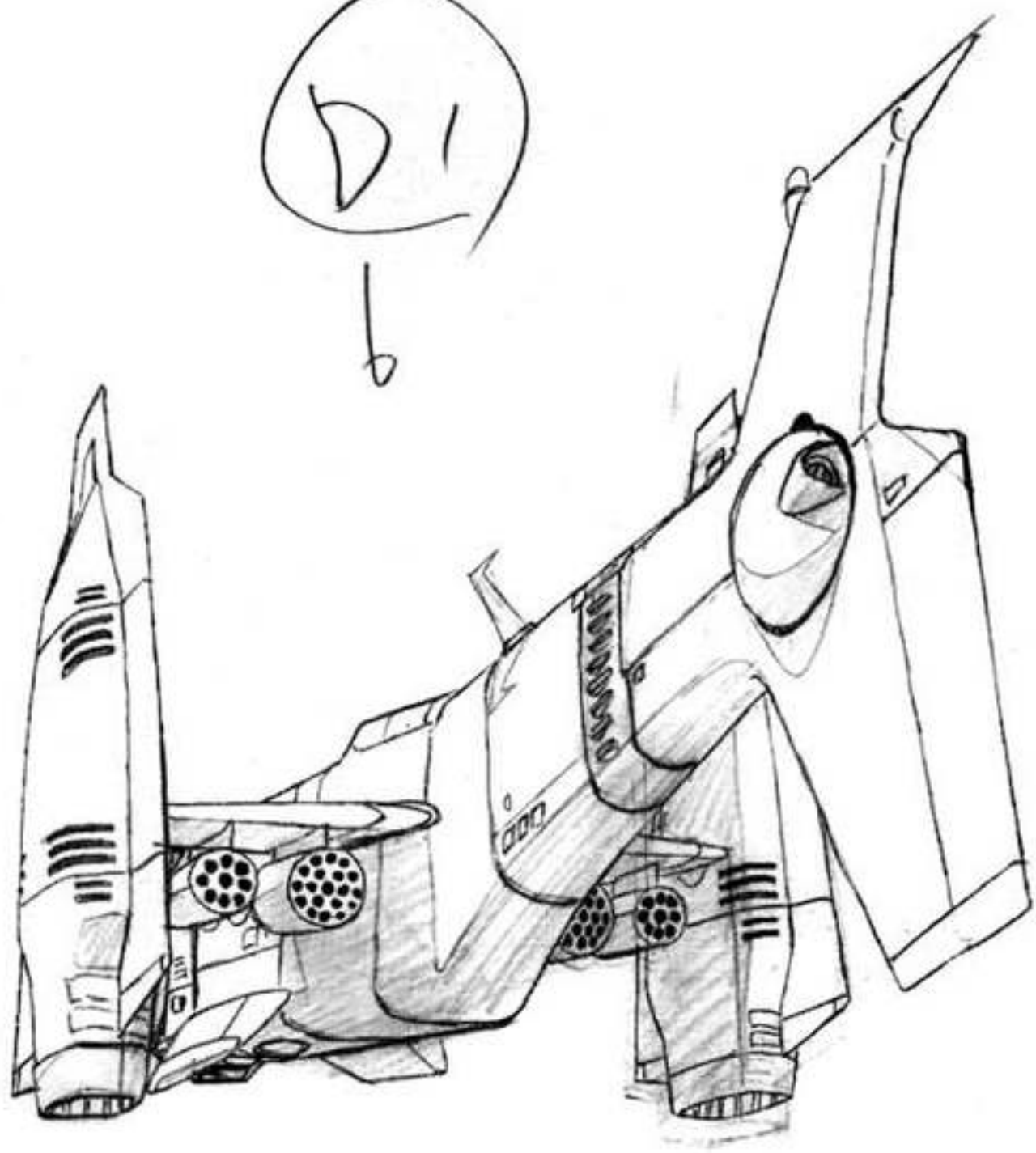
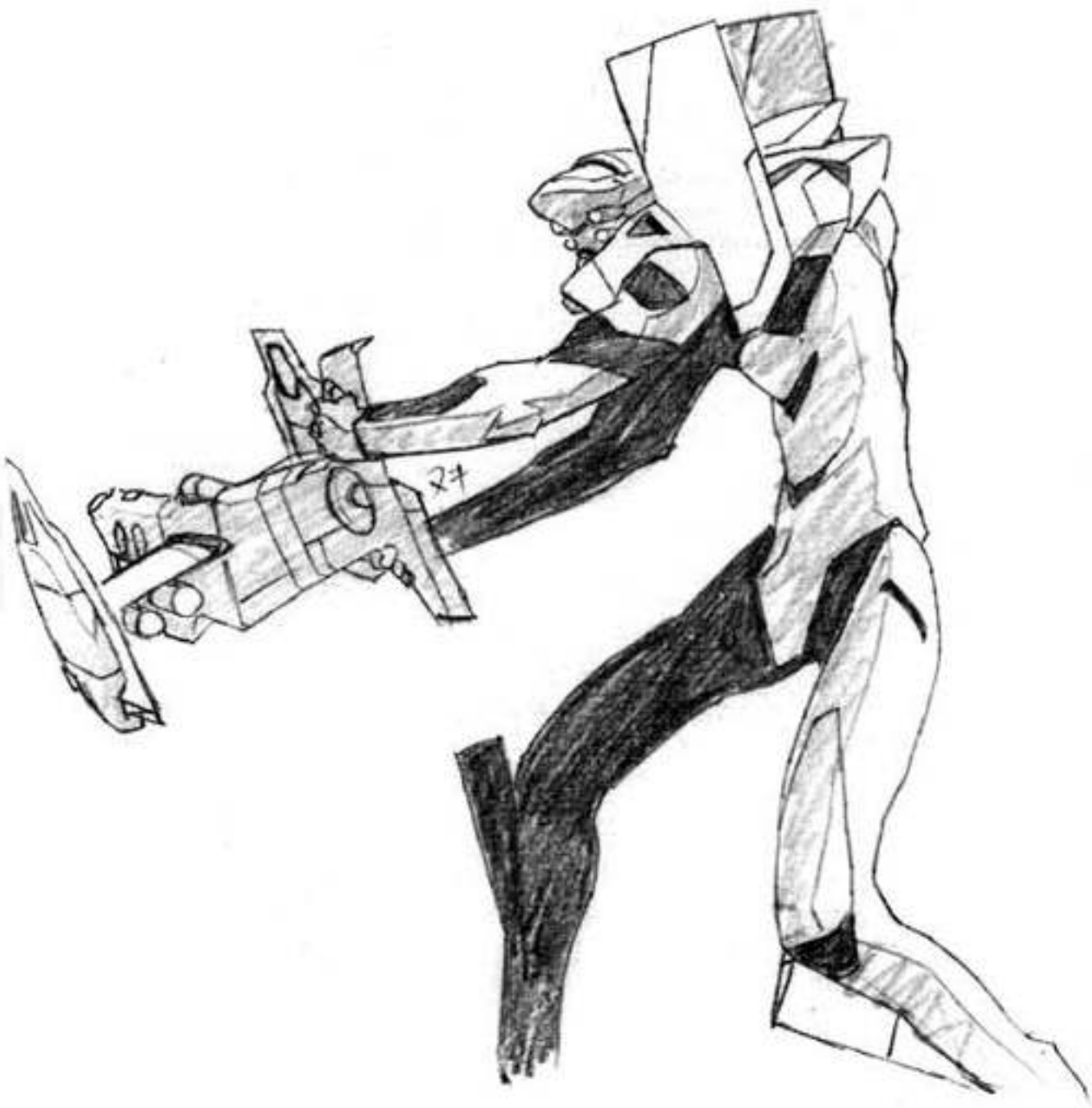

(d4)

(d2)

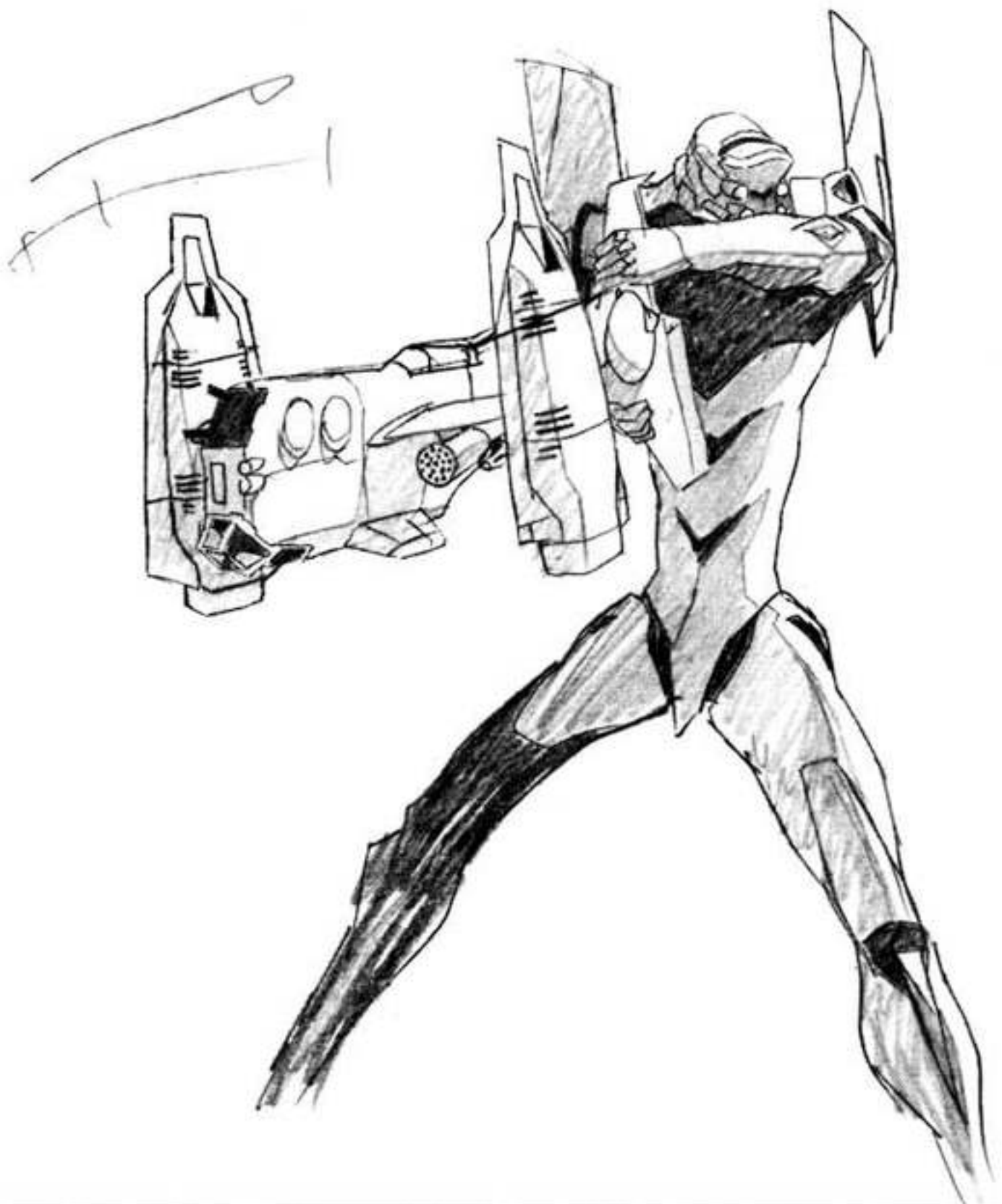

(23)





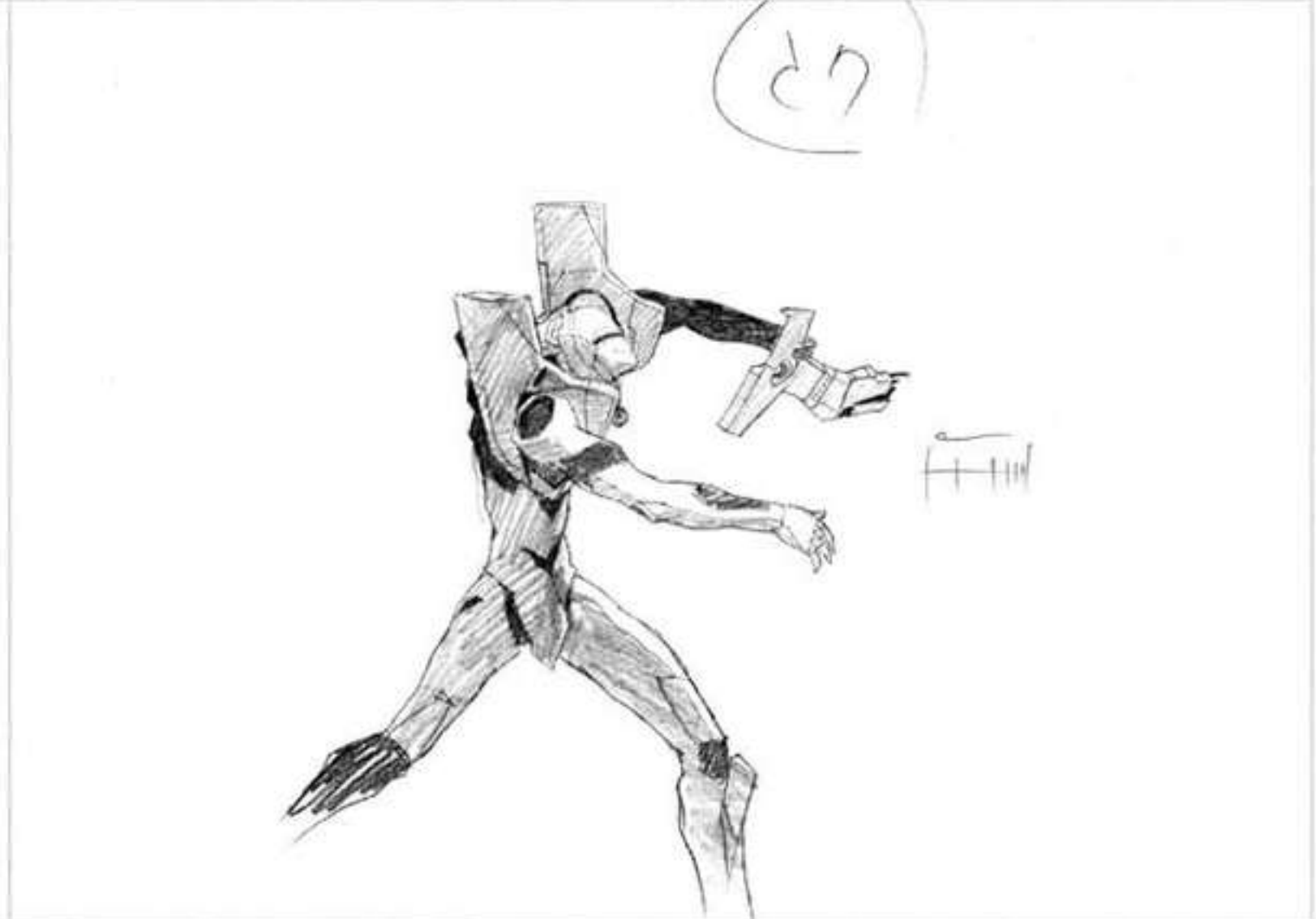
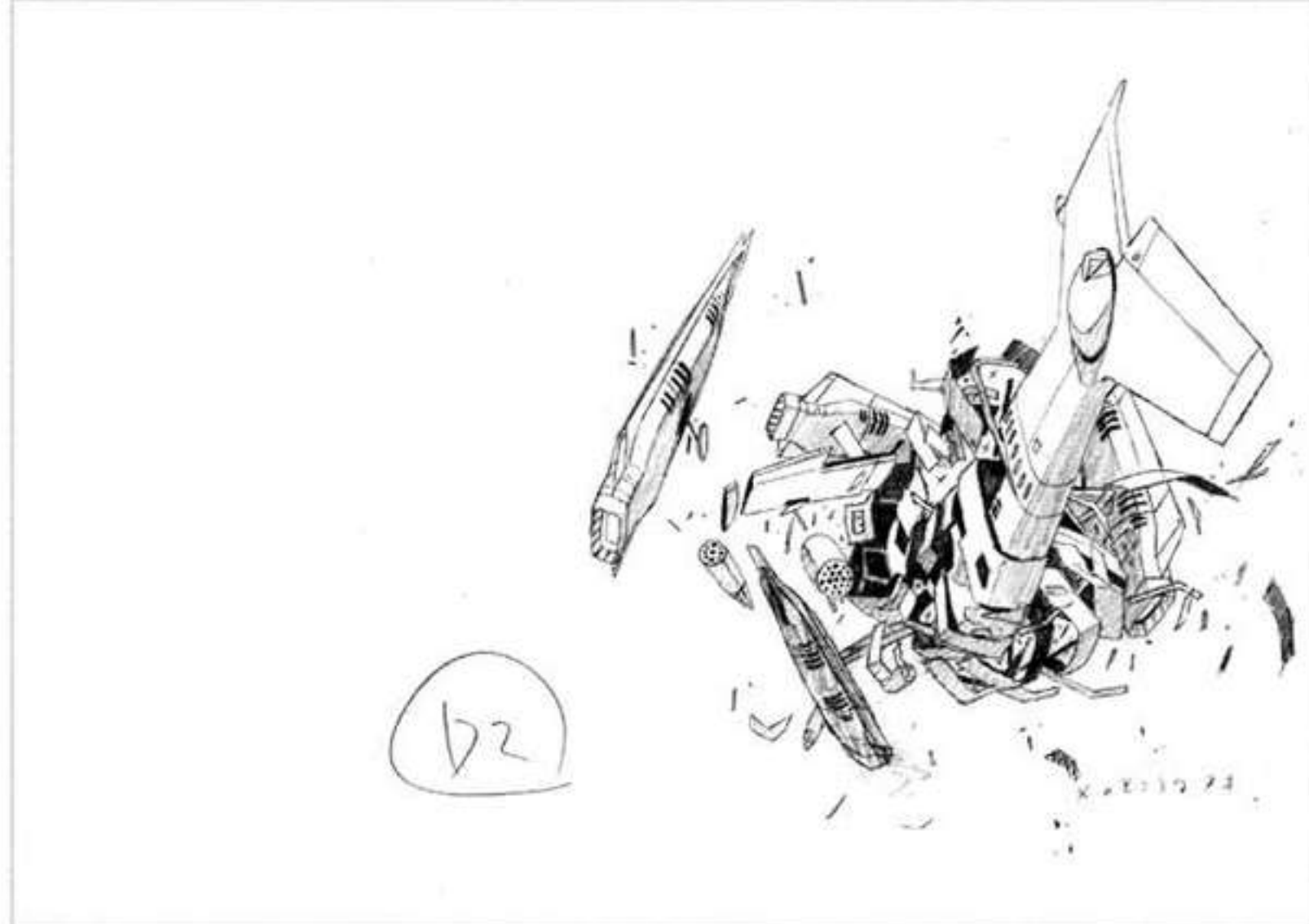
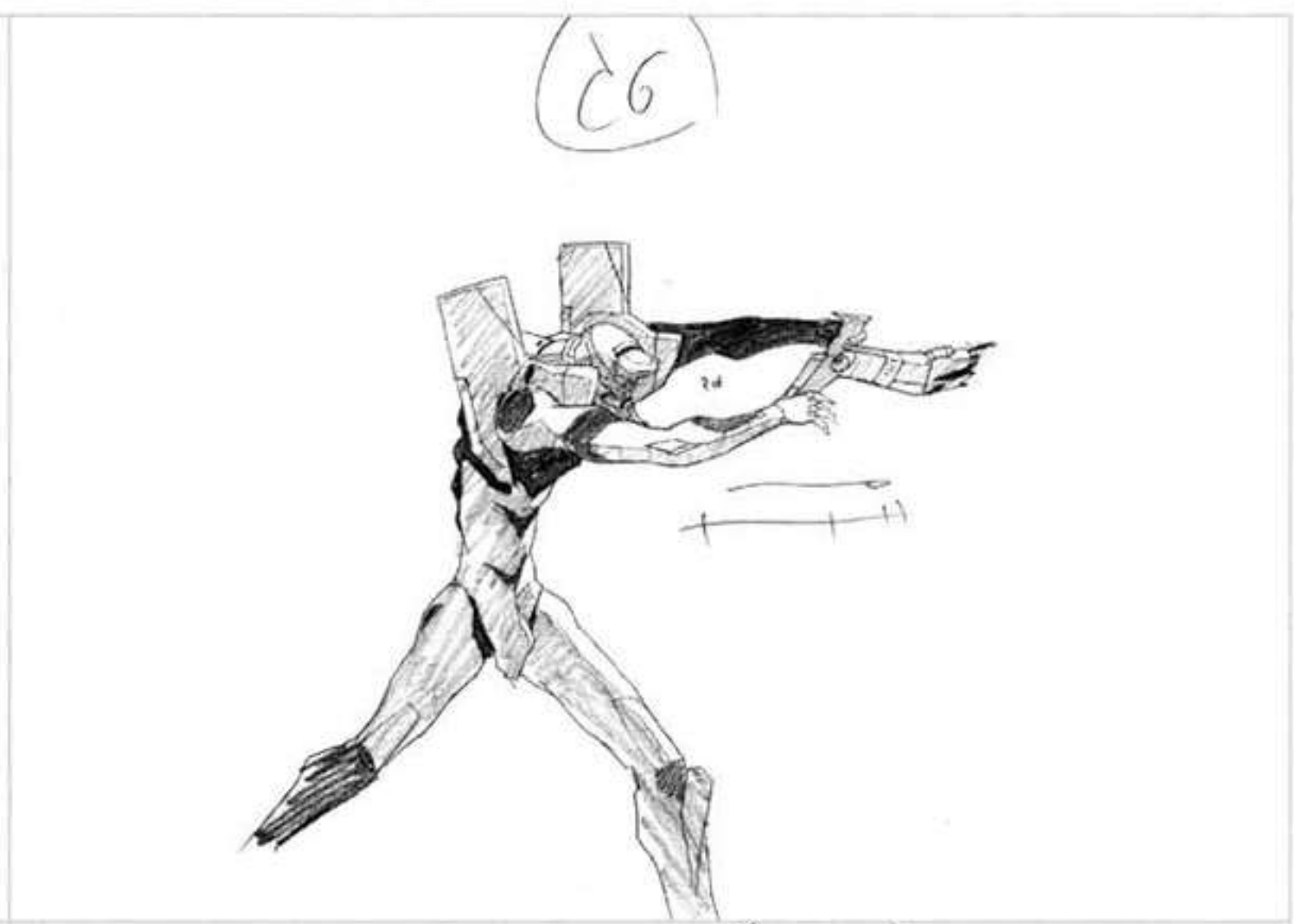
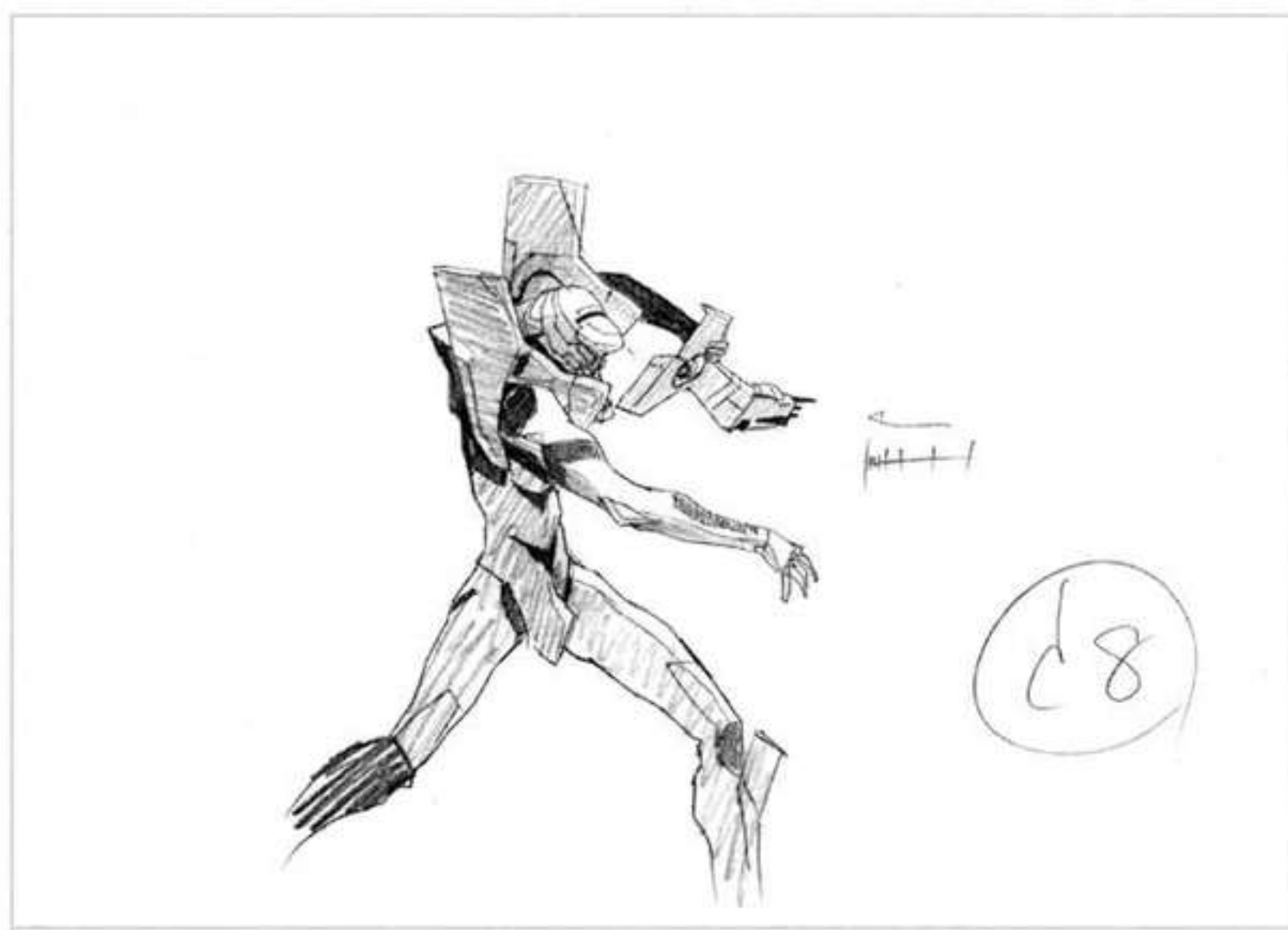
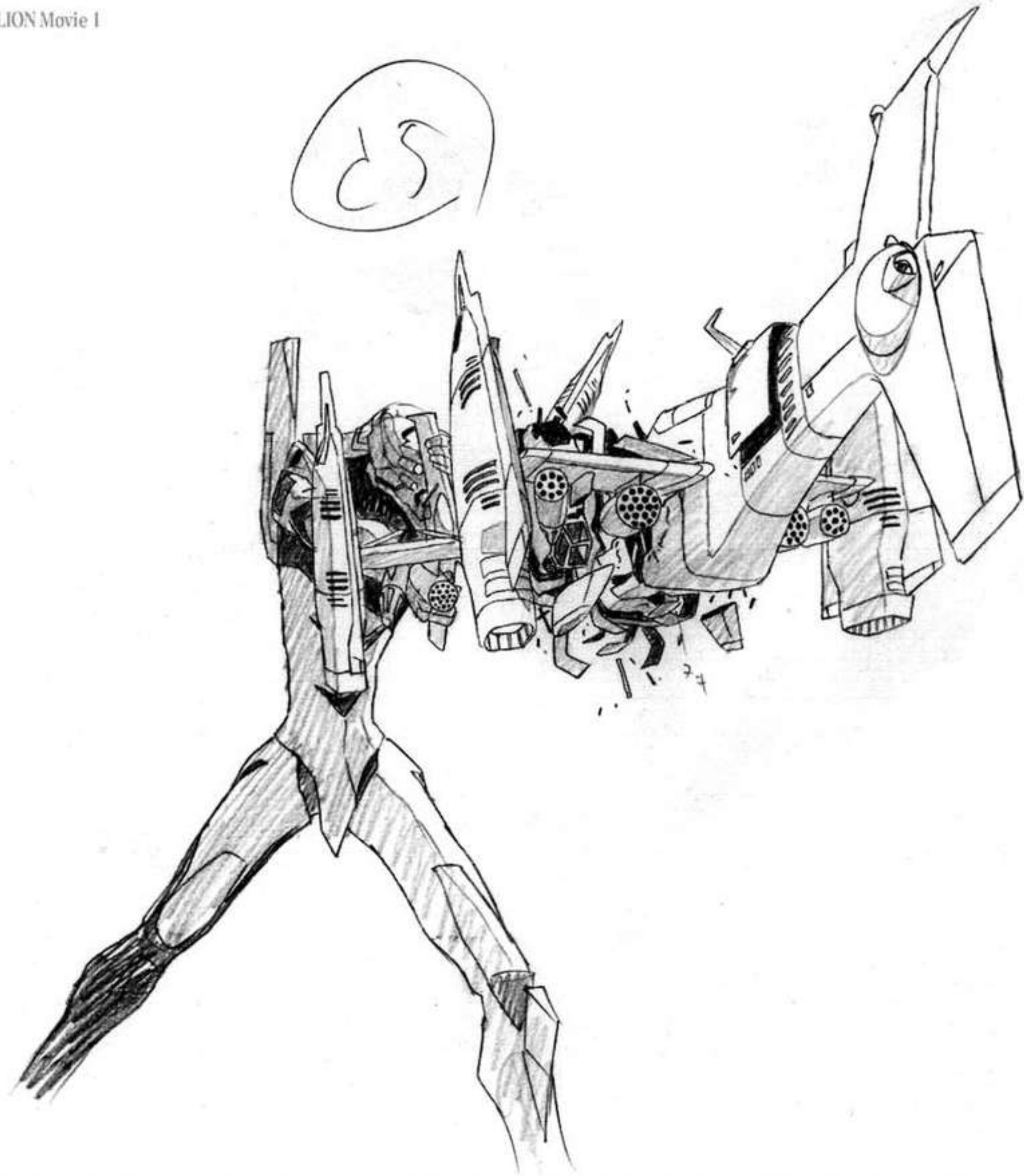





#25-C386

タイムシート

A	B	C	D	
X	0	0	0	2
				4
				6
				8
				10
				12
				14
	2			16
				18
2				20
				22
			3	24
				26
		4		28
1	5	X		30
			2	32
				34
	6	3		36
				38
				40
				42
				44
		4		46
				48

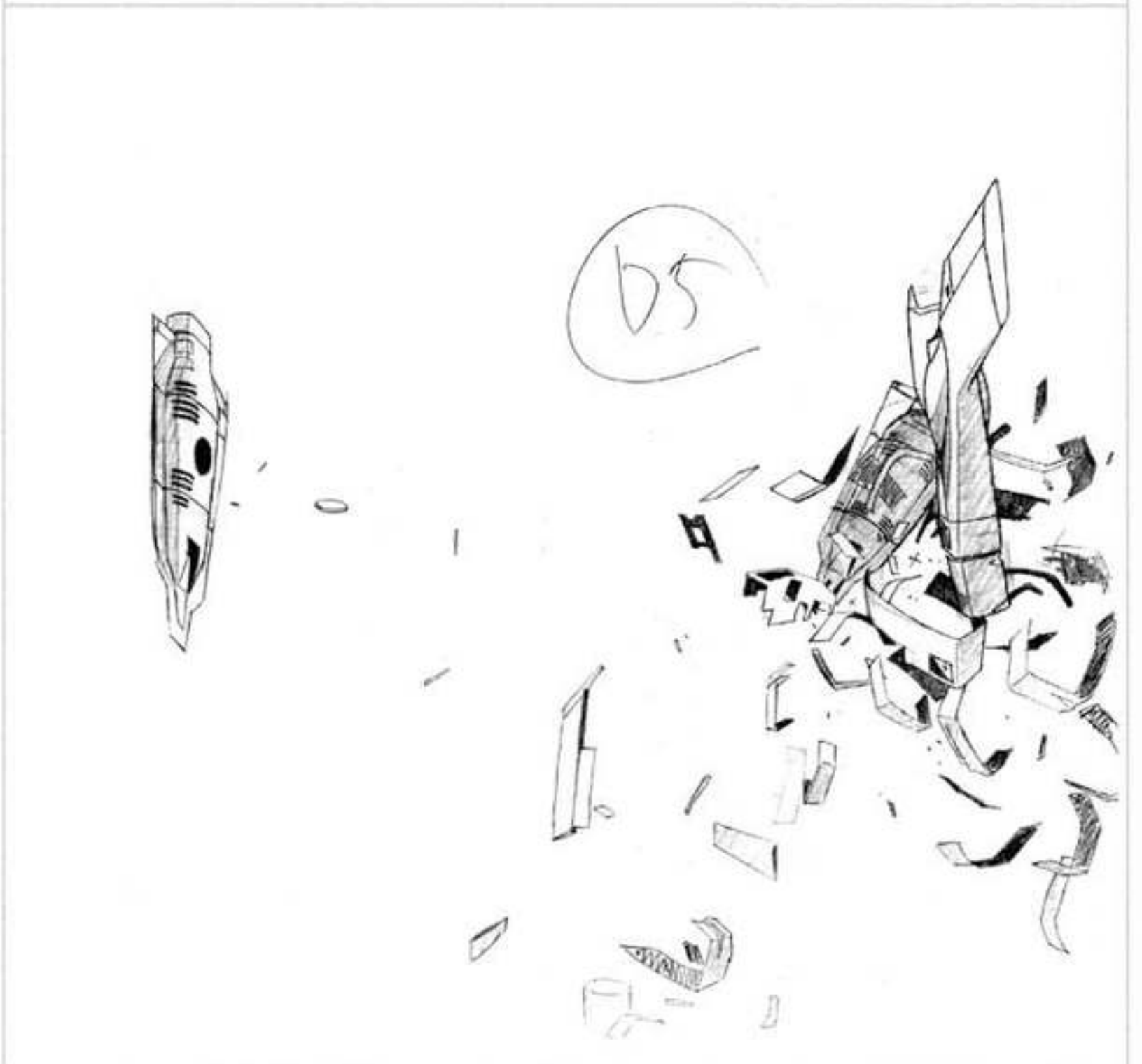
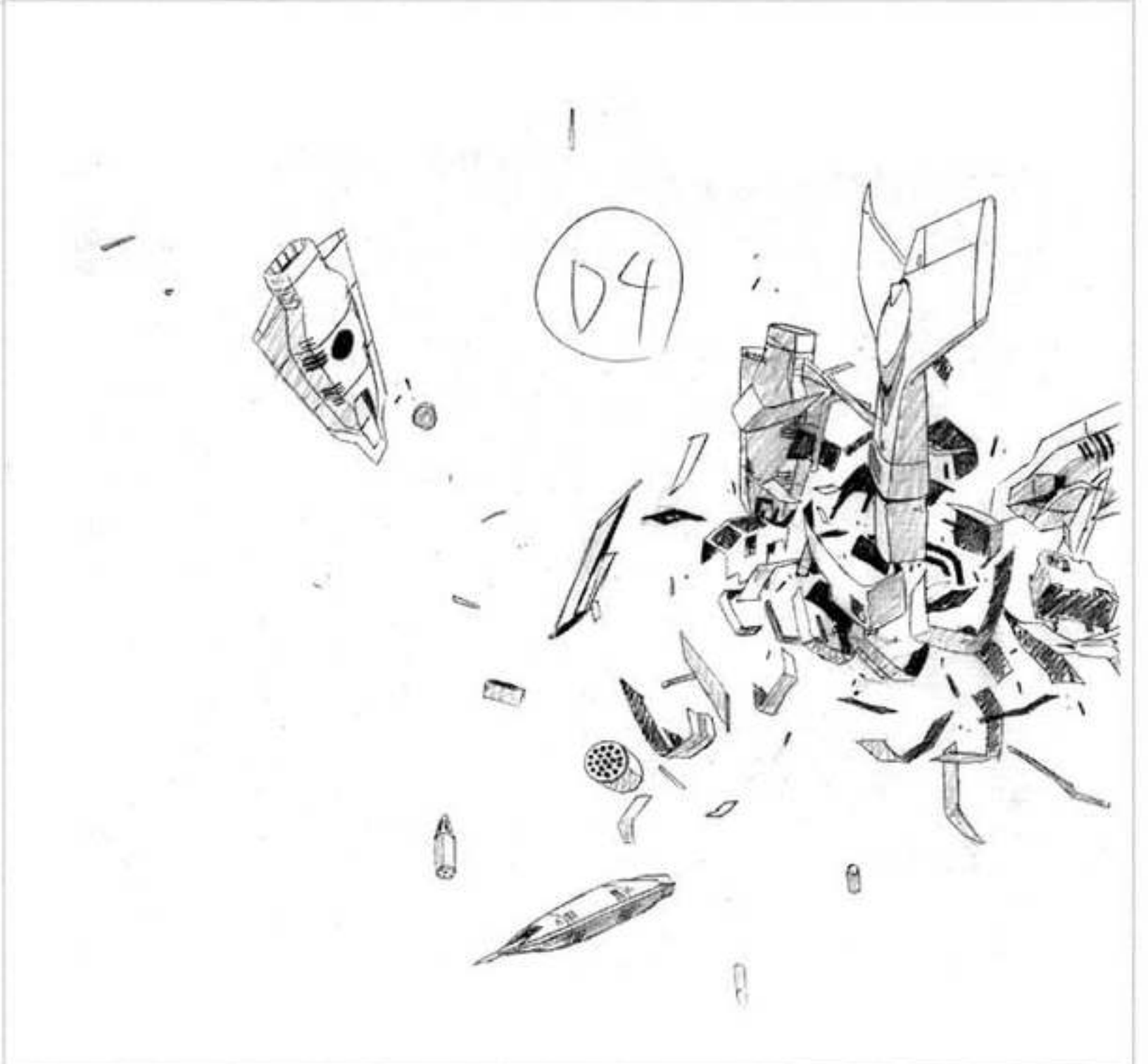



修正原画

(A1)

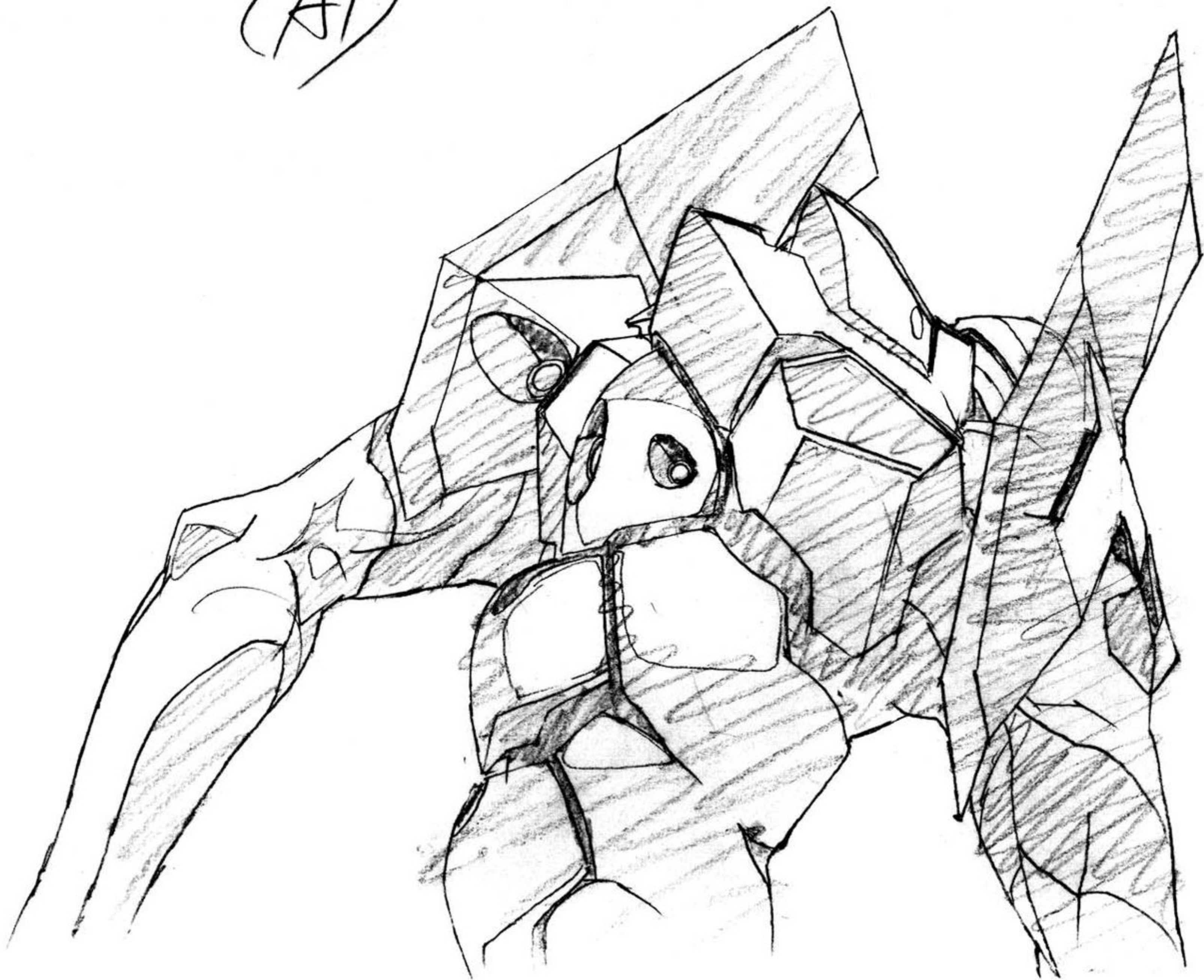

#25-C387

修正原画

(A3)

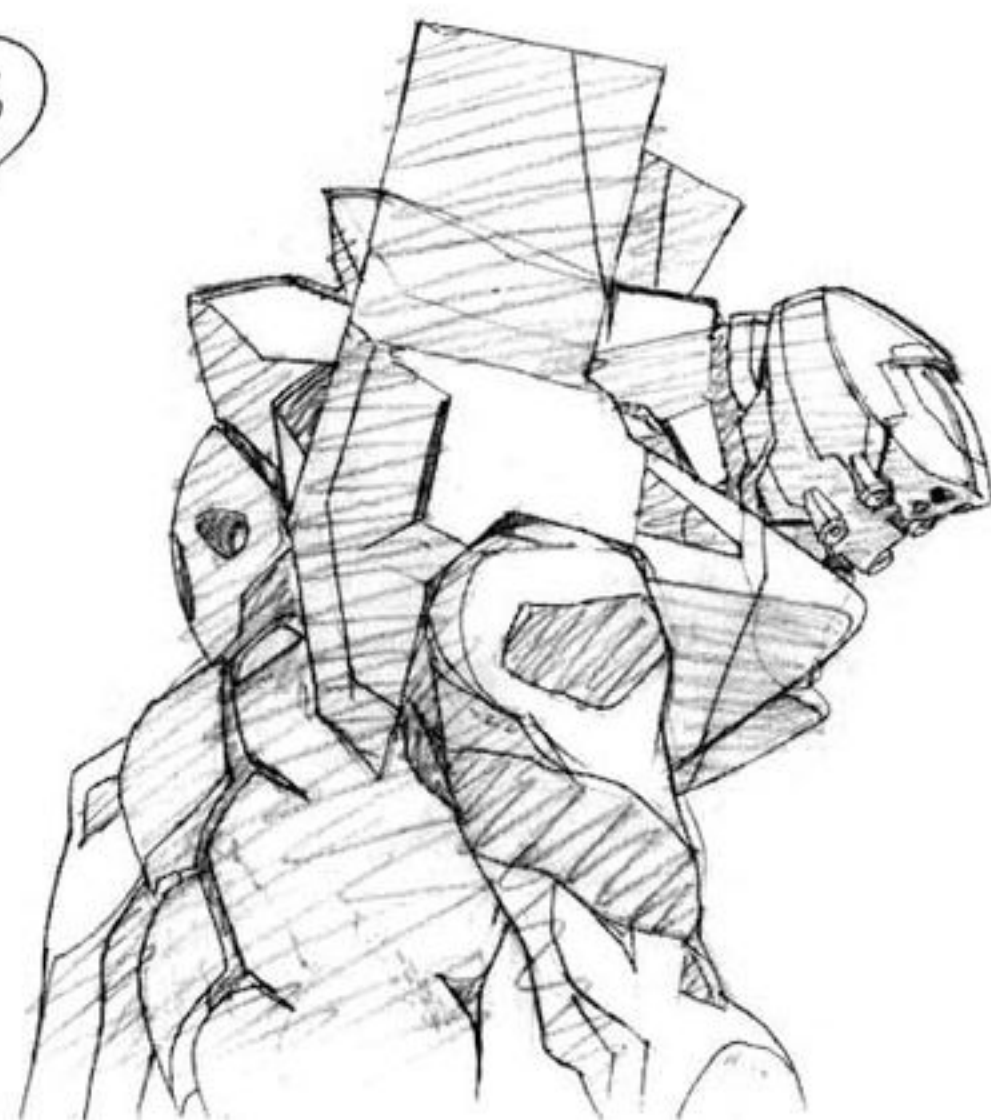

修正原画

(A2)

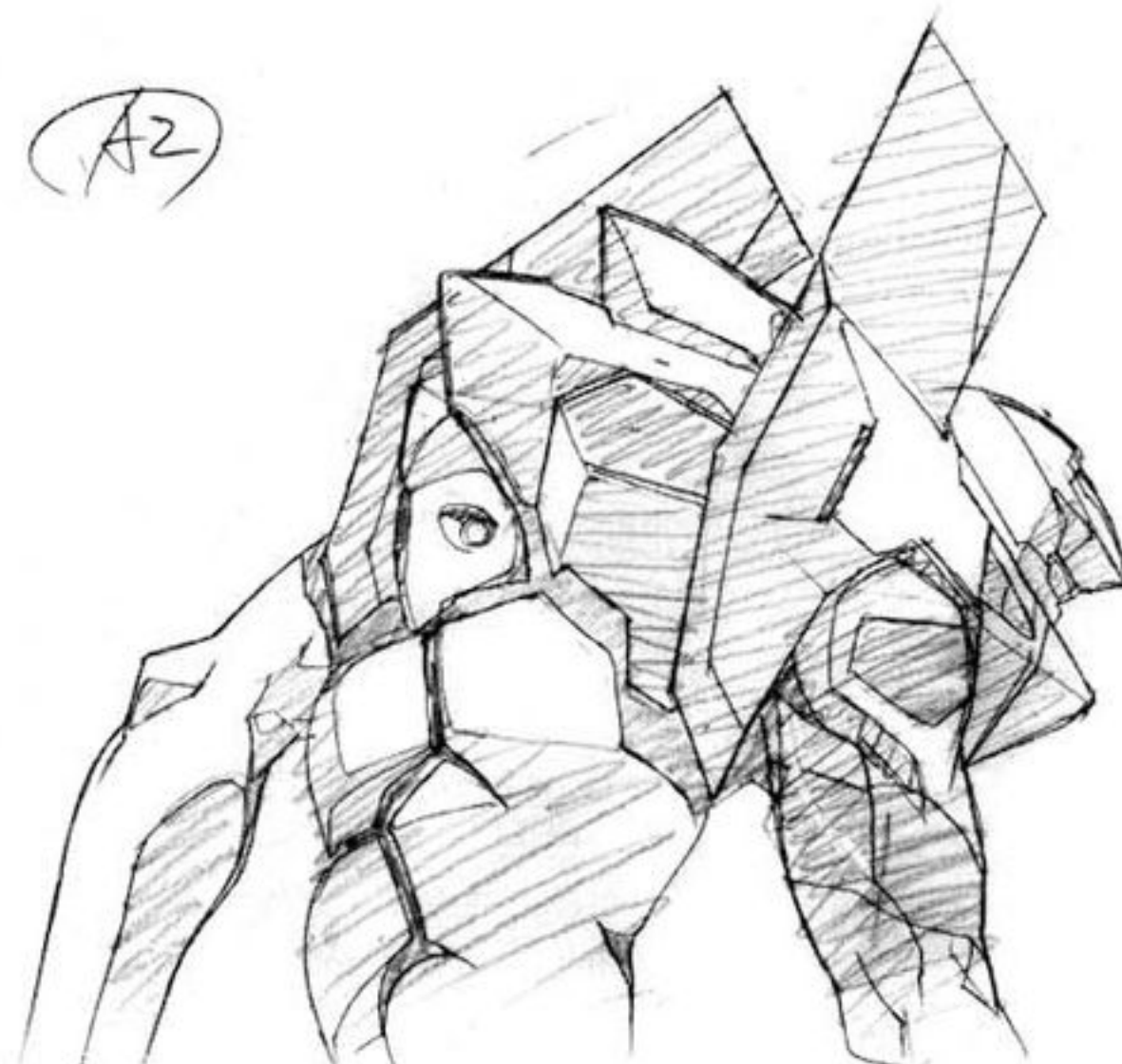



修正原画

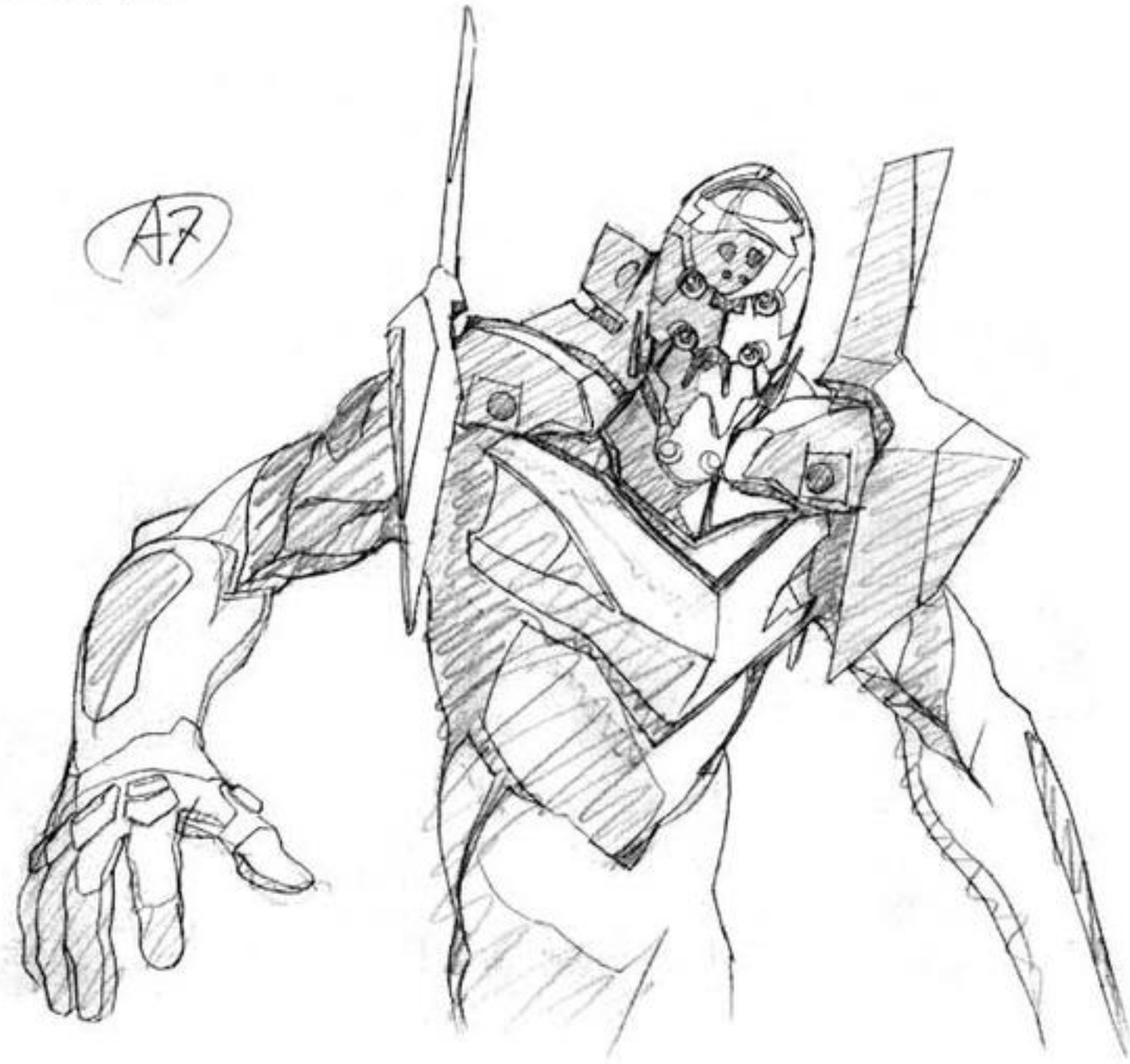

修正原画



修正原画



修正原画

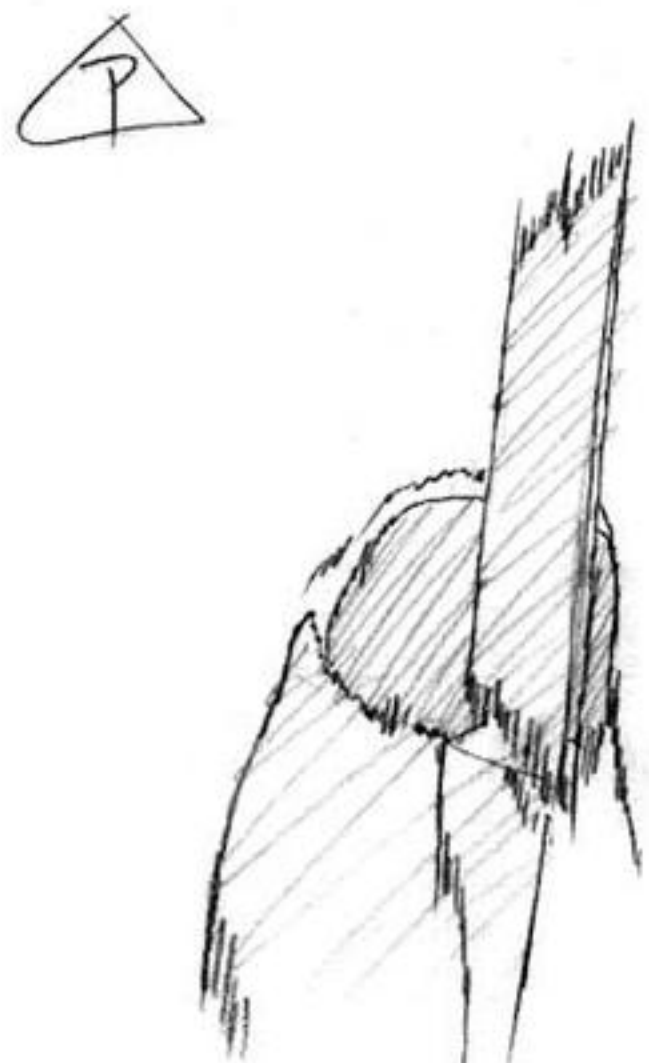

修正原画

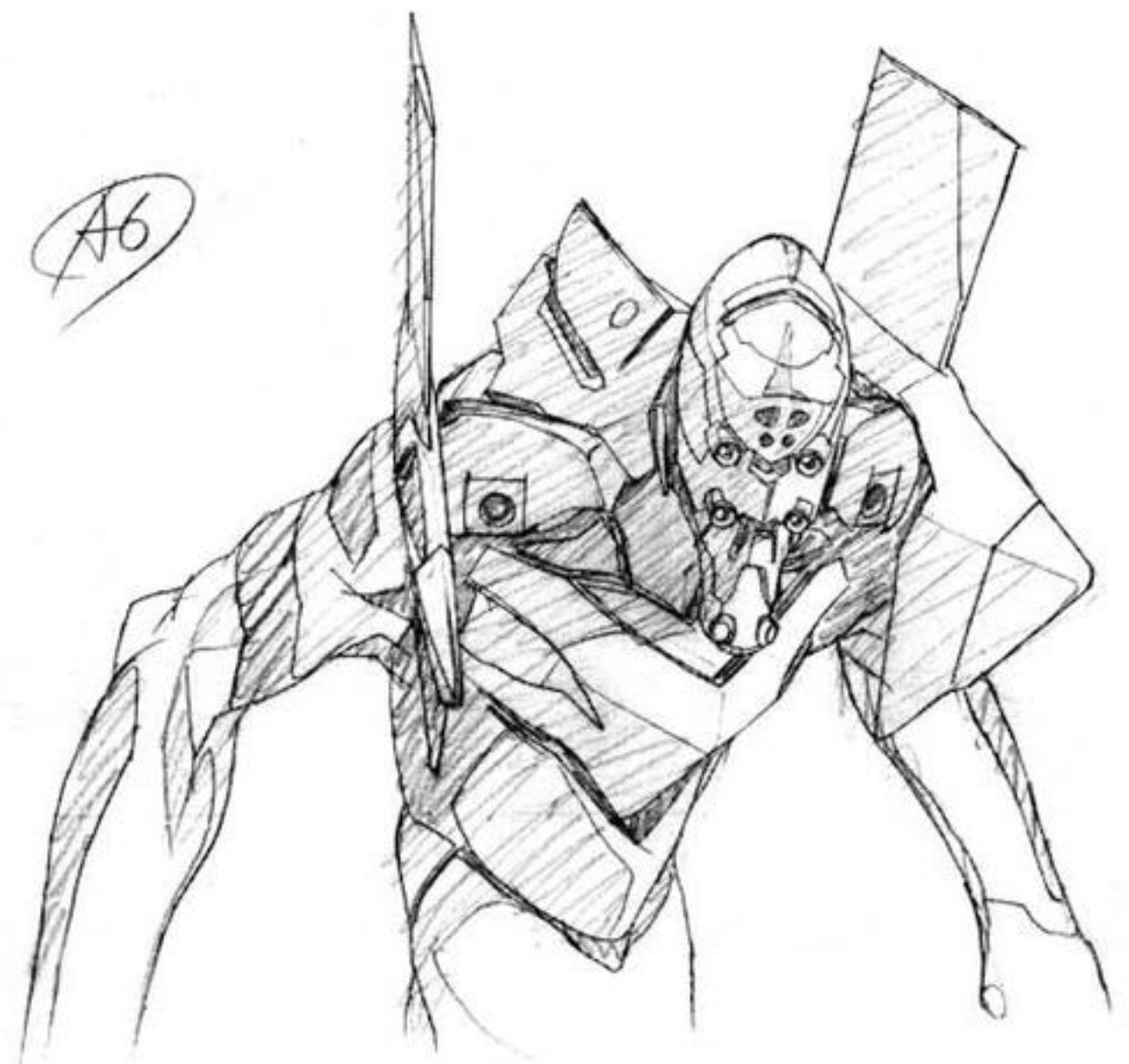



修正原画

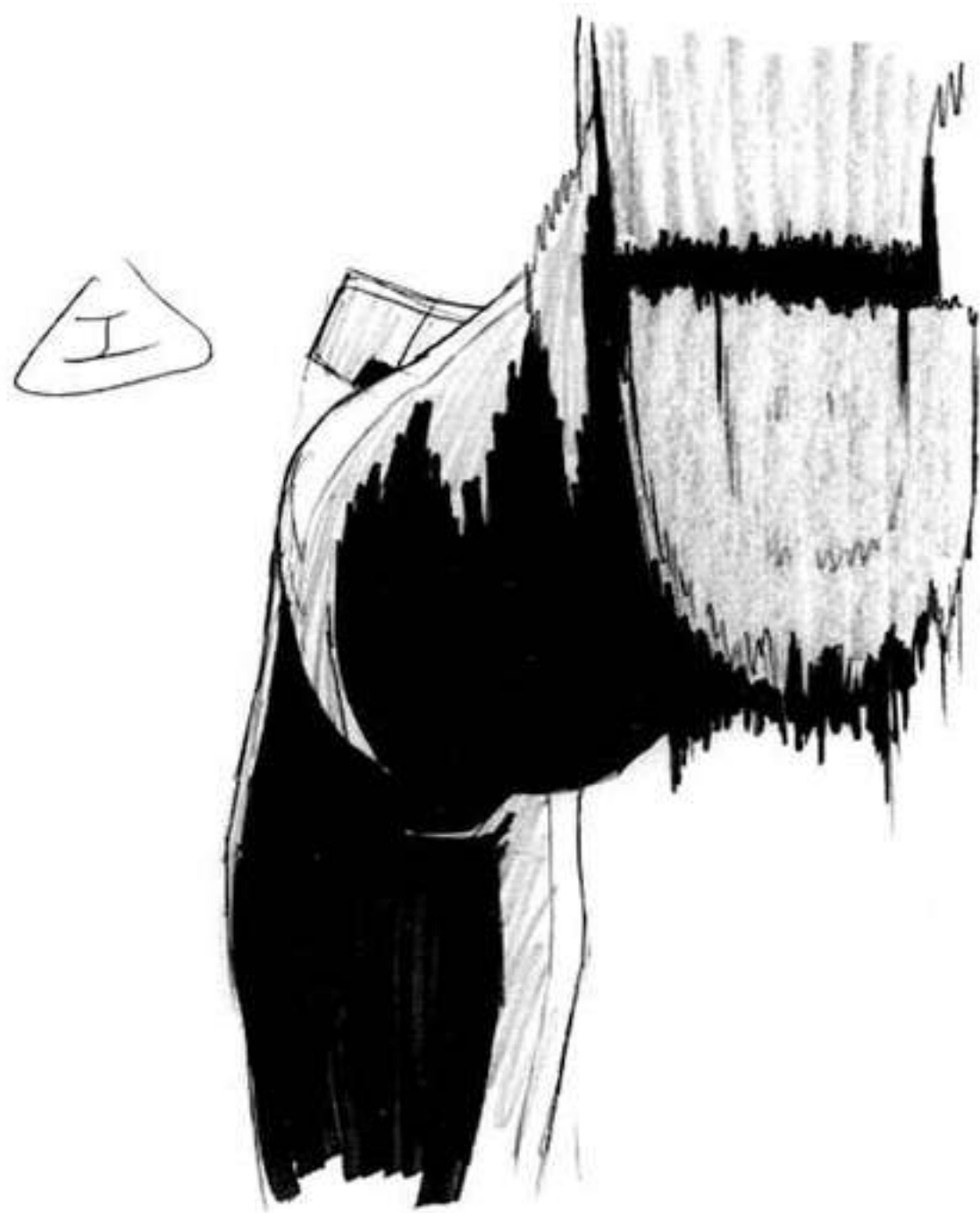

修正原画

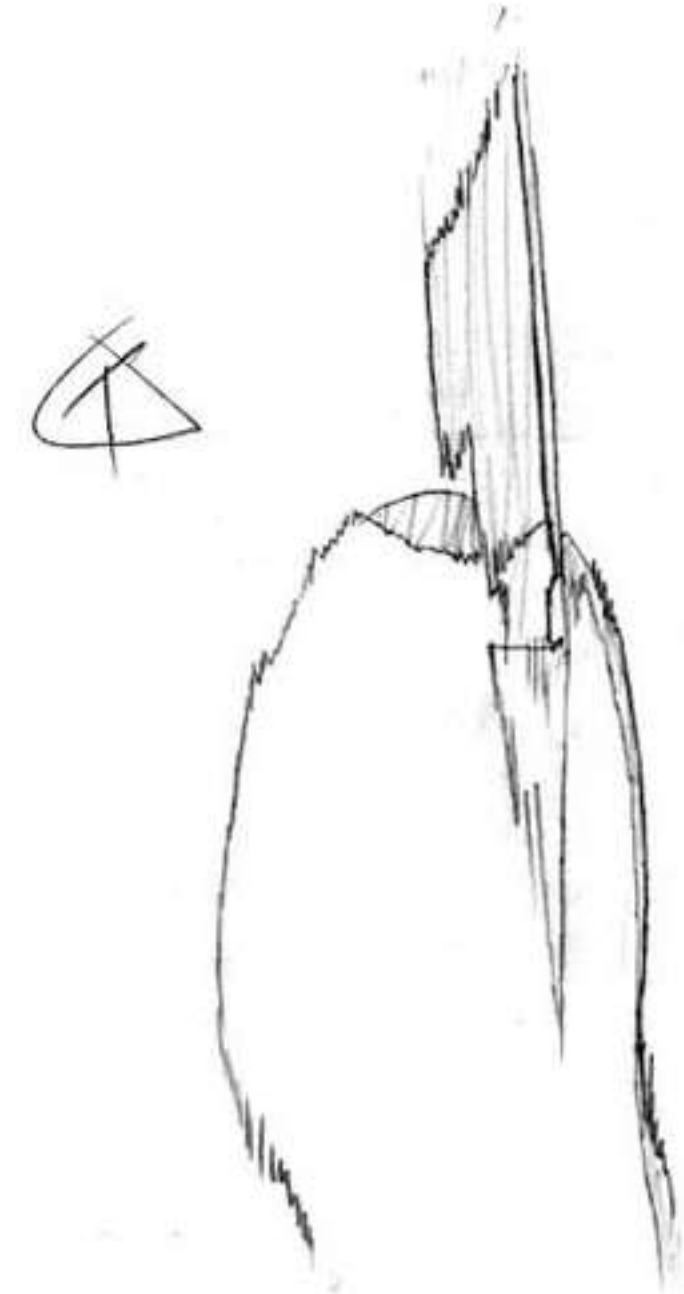

修正原画

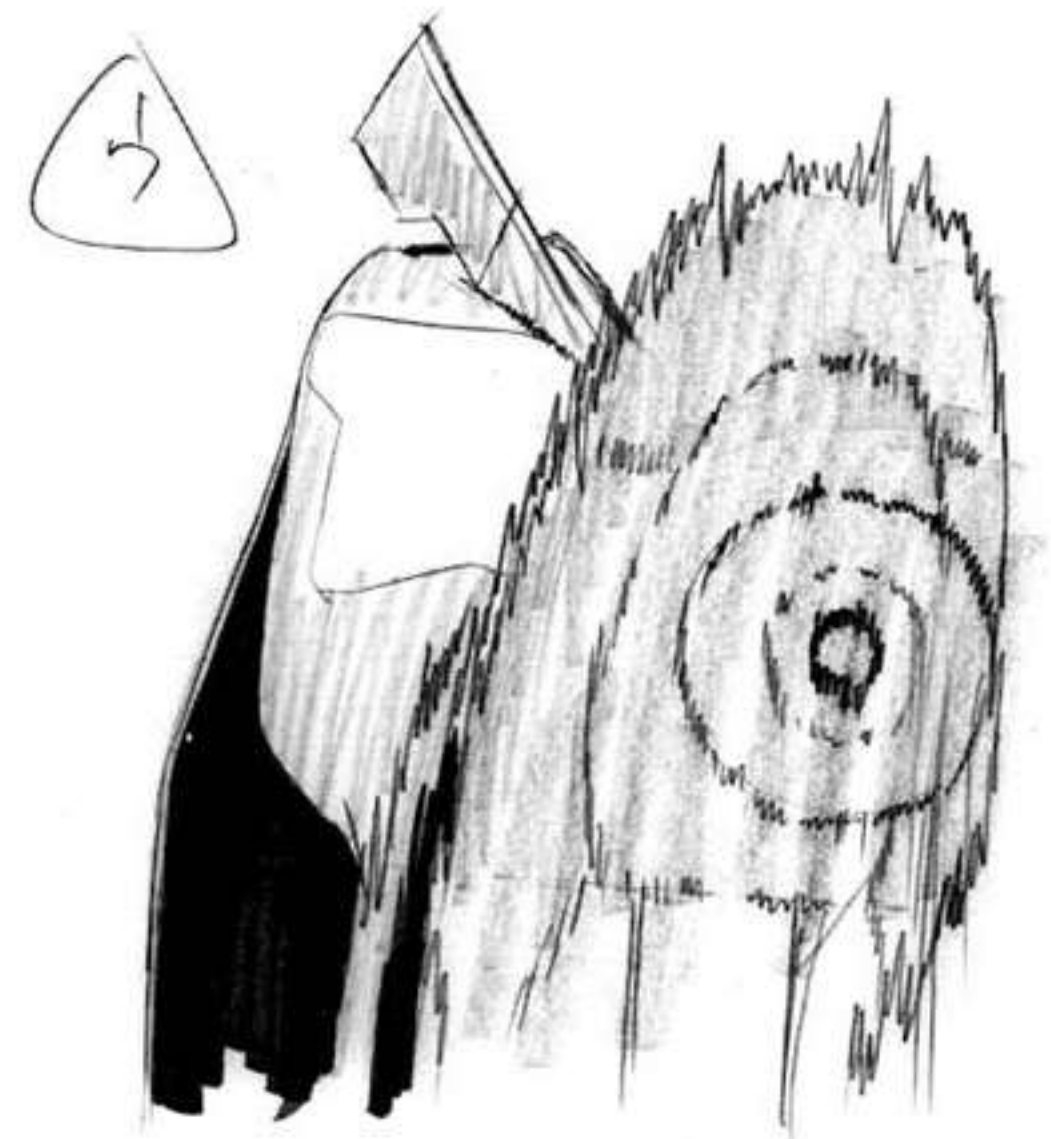



修正原画

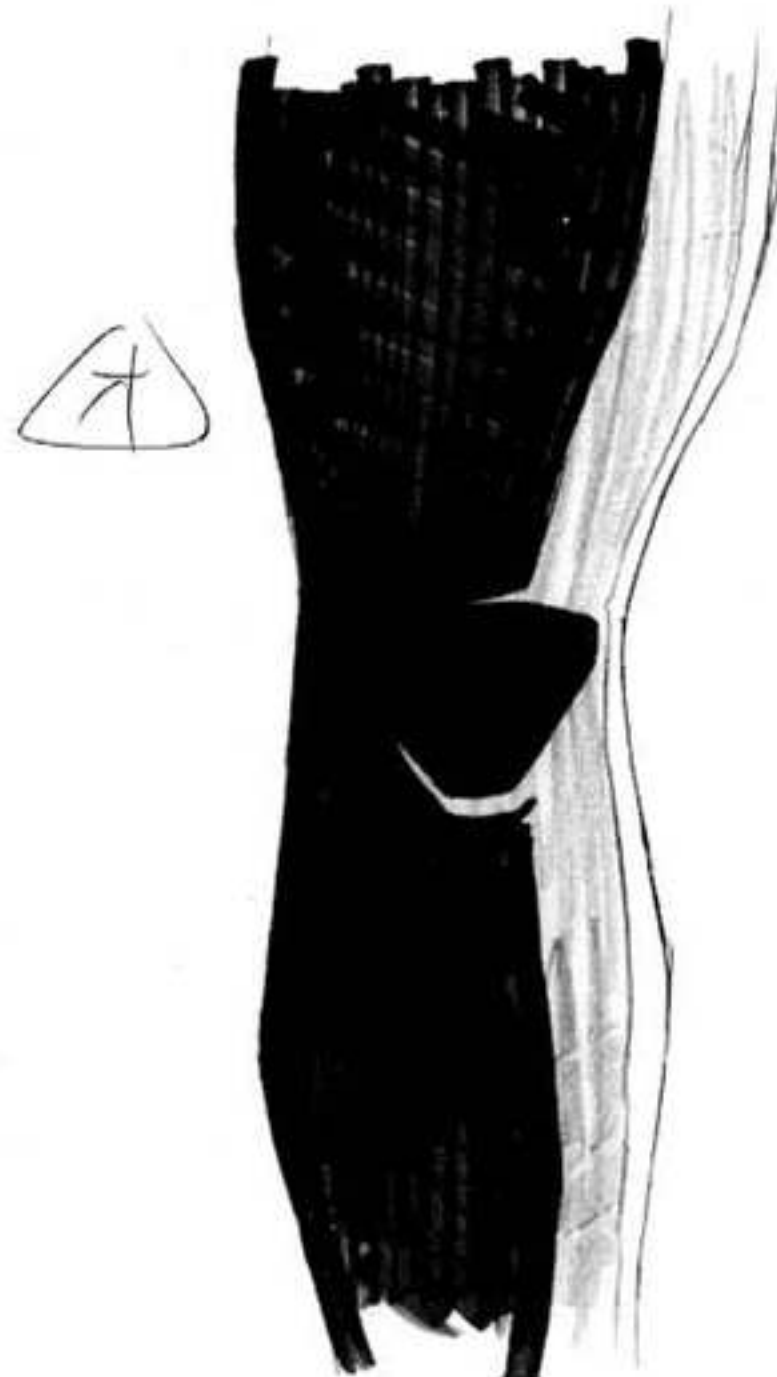
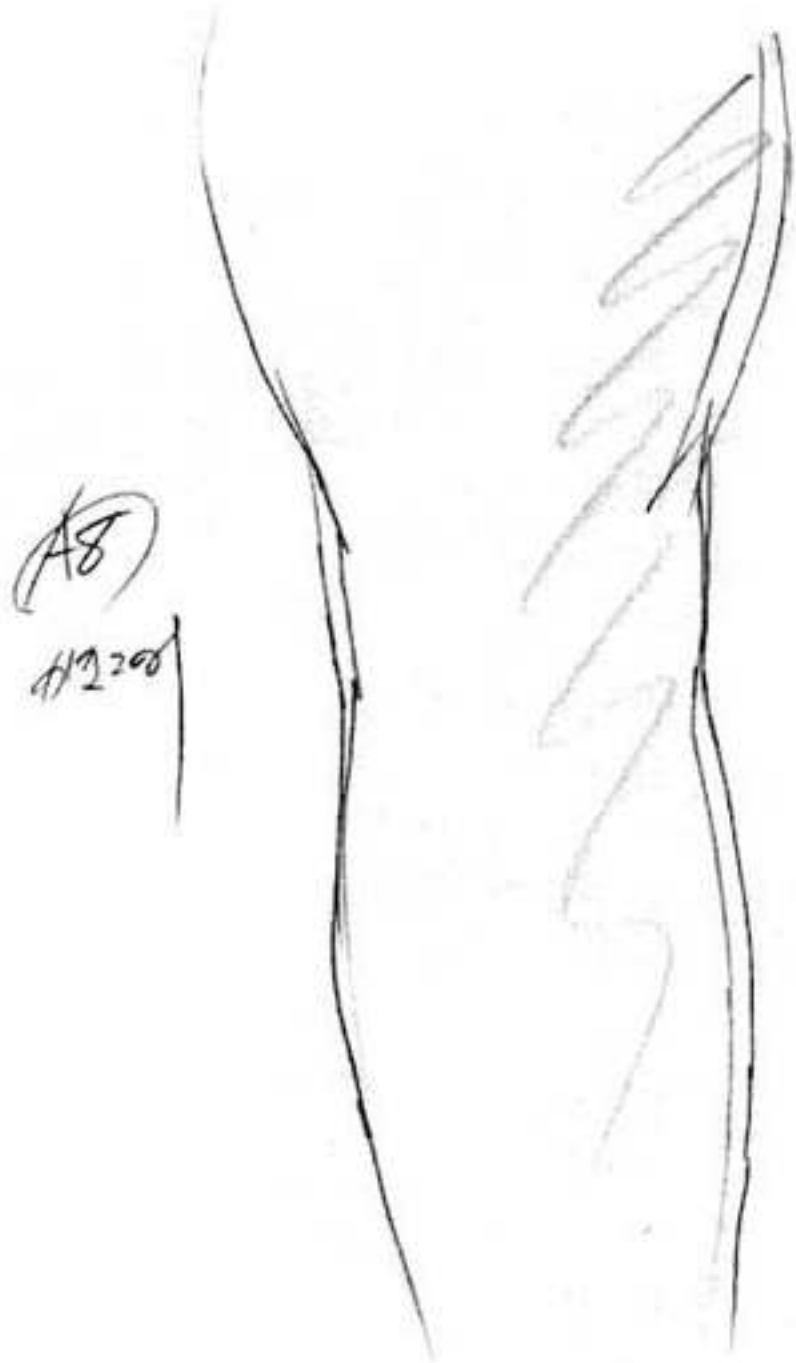

修正原画

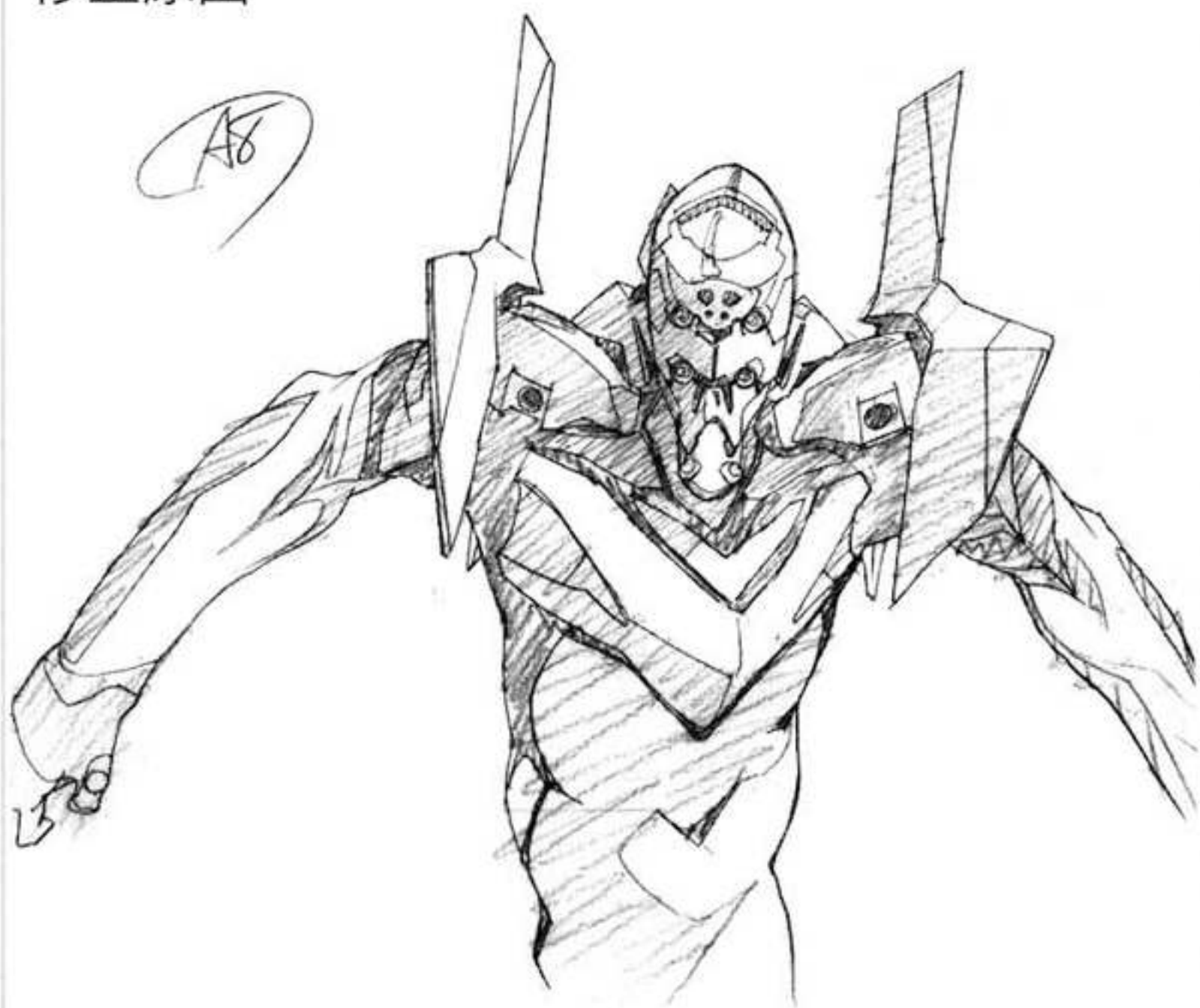

修正原画

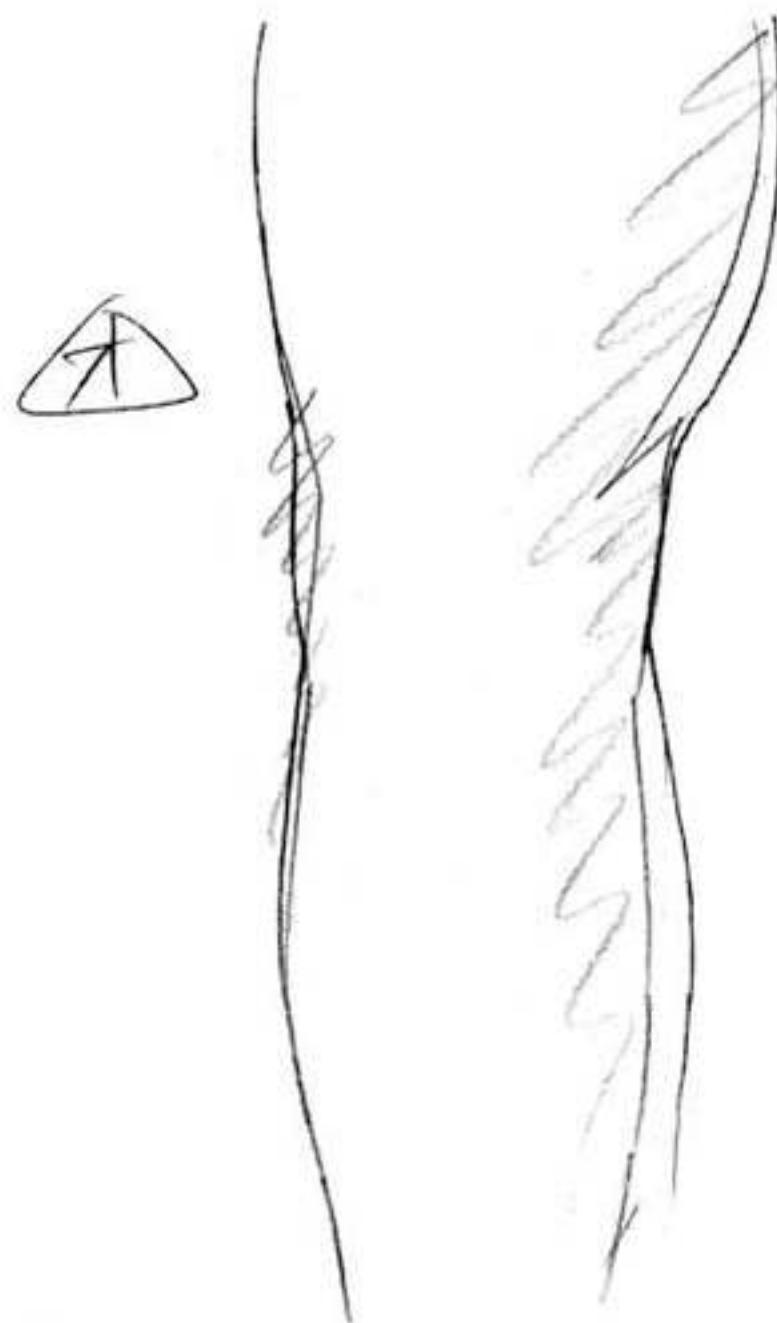

#25-C387

AB	BC	CD
0	X	X
1	0	1
2	2	0
3	3	7
4	4	2
5	5	10
6	6	4
7	7	0
8	8	3
9	9	5
10	10	7
11	11	2
12	12	4
20	20	6
30	30	7
31	31	2
32	32	4

14	3
5 15	42
6 16	5
7 17	24
8 18	7
9 19	2
10 20	38
11 21	4
12 22	140
13 23	6
14 24	32
15 25	8
16 26	94
17 27	X
18 28	46
19 29	48
20 30	50
21 31	52
22 32	54
23 33	56
24 34	58
25 35	60

4	62
1	64
1	66
1	68
1	70
1	72
1	74
1	76
1	78
5	80
1	82
1	84
1	86
6	88
6	90

1	92
1	94
1	96
7	98
ア	100
イ	102
ウ	104
エ	106
100	100

タイムシート







#25-C400



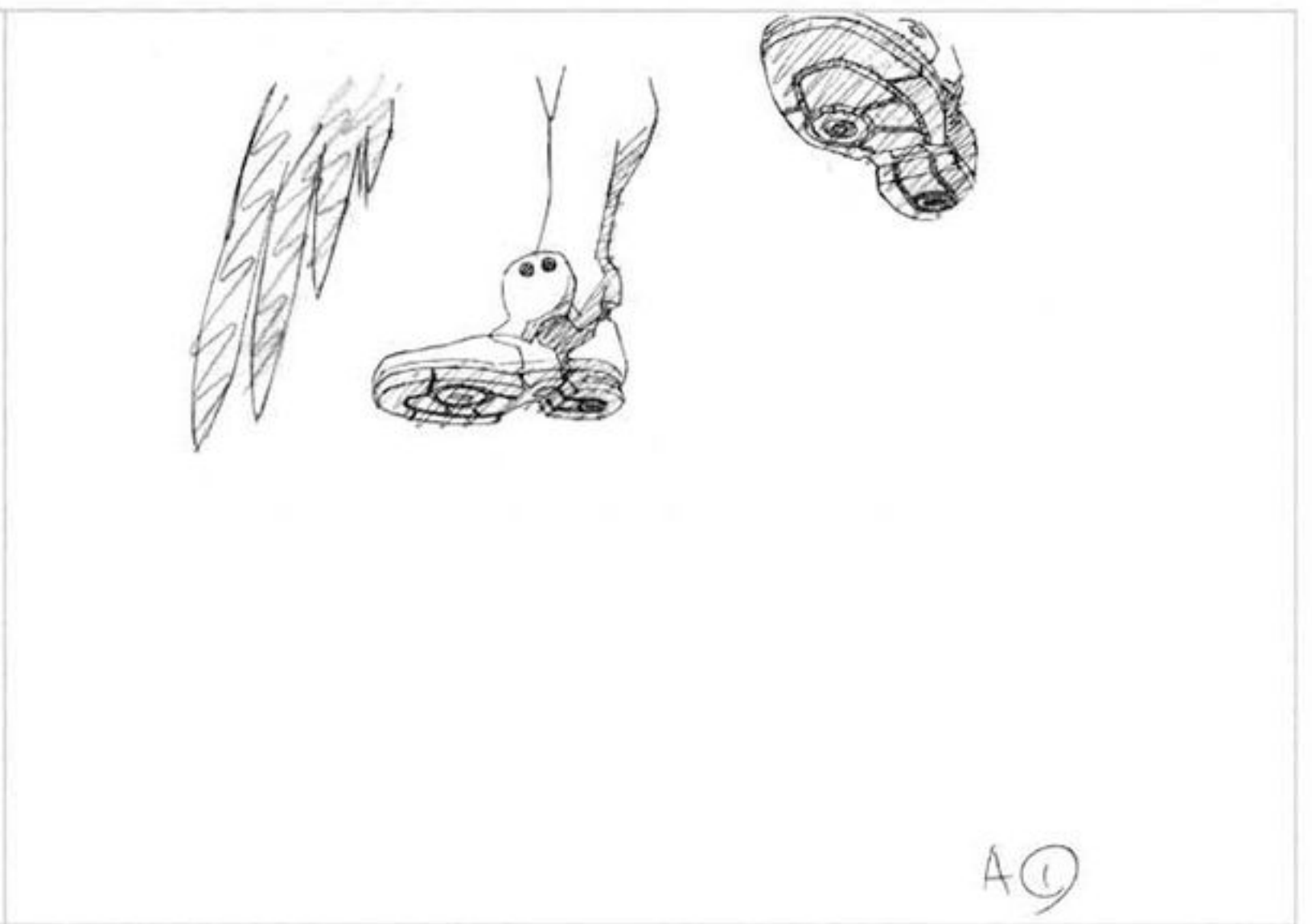

#25-C405

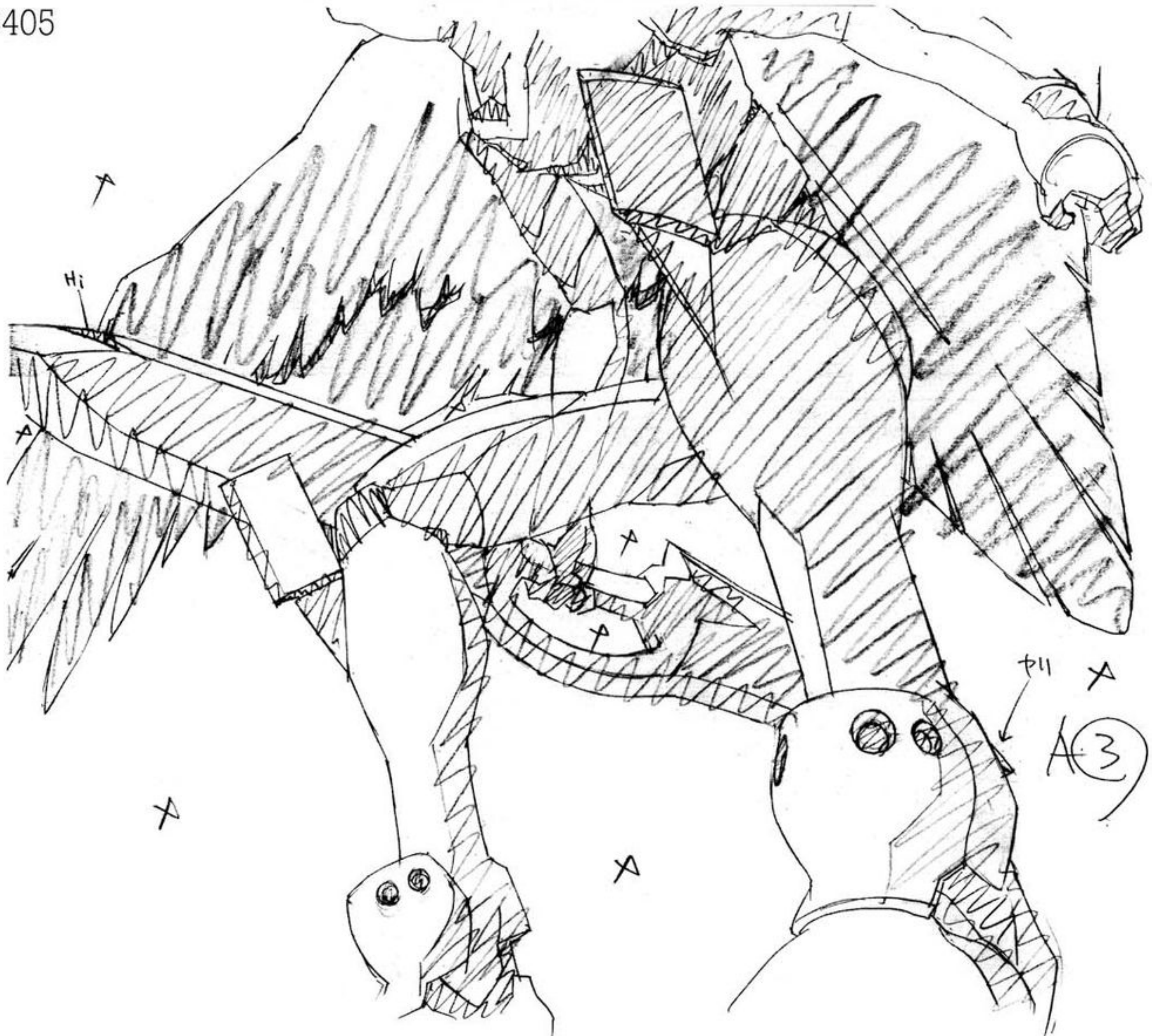





タイムシート

A	B	
X	X	
①		2
、		4
		6
Ⓐ		8
、		10
②		12
③①		14
Ⓐ、		16
、		18
、②		20
		22
、		24
		26
、		28
、		30
		32
④③		34
		36

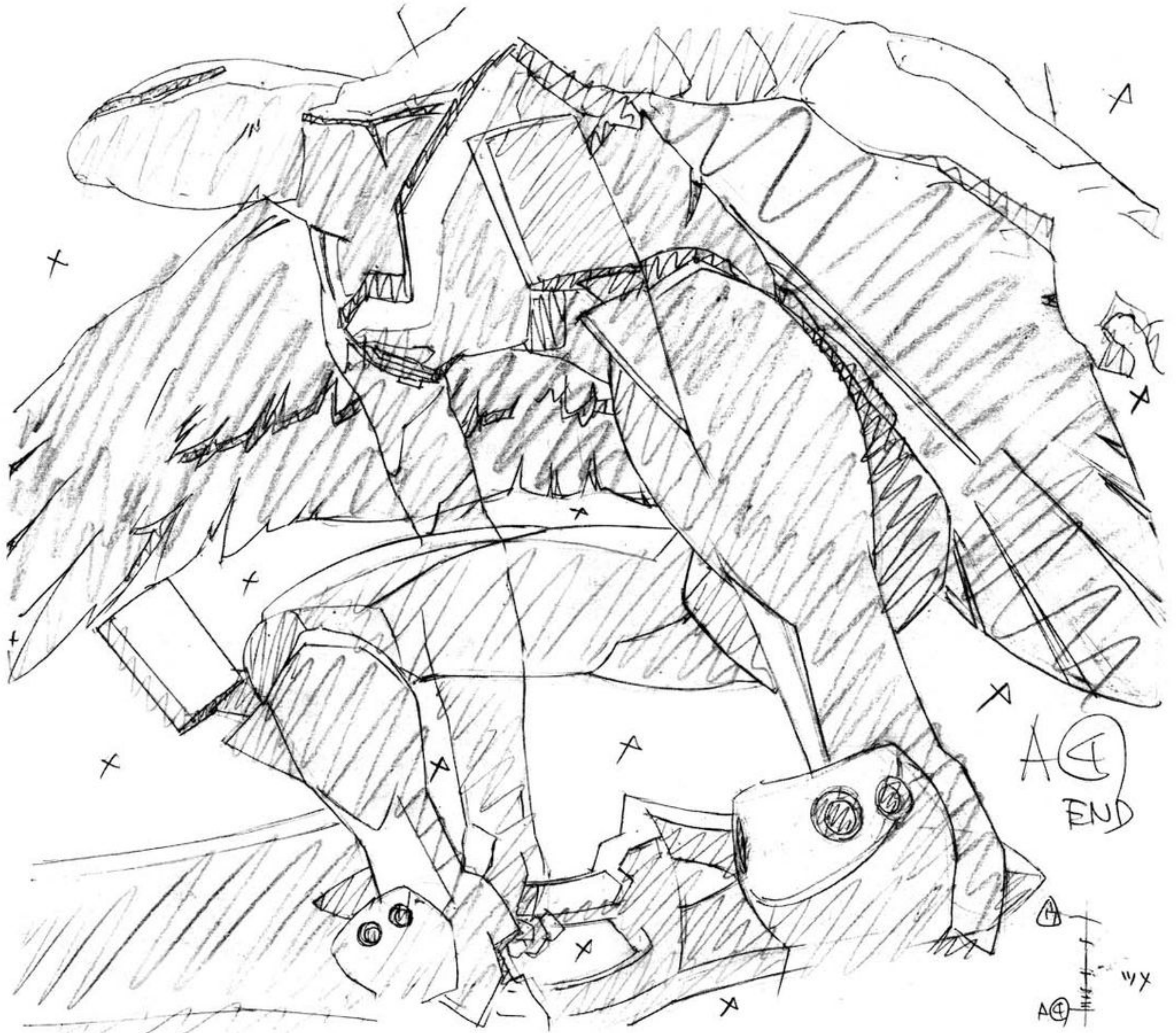



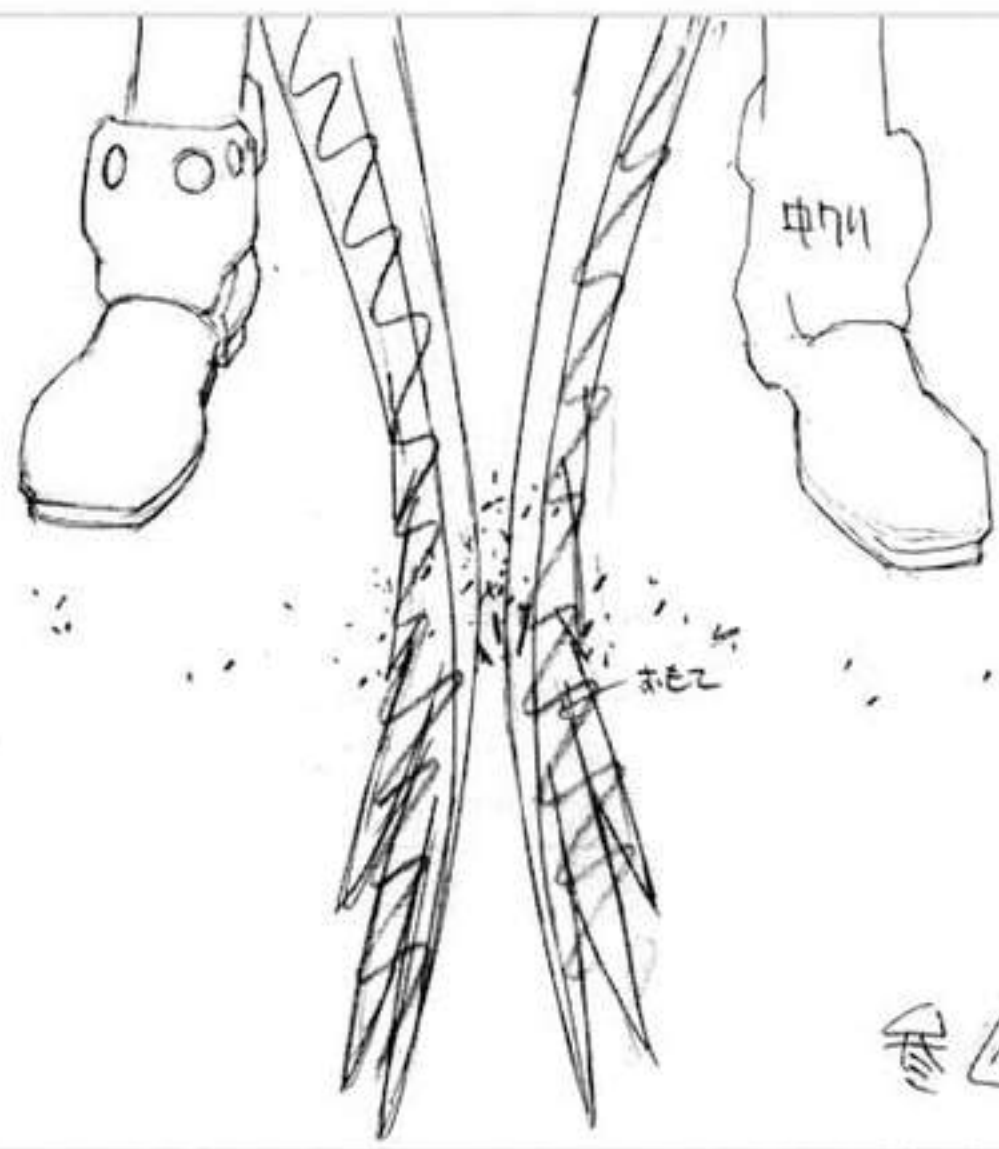

参A



↑ ↑  
⊗ = 足底  
AQ スラッシュ

A①

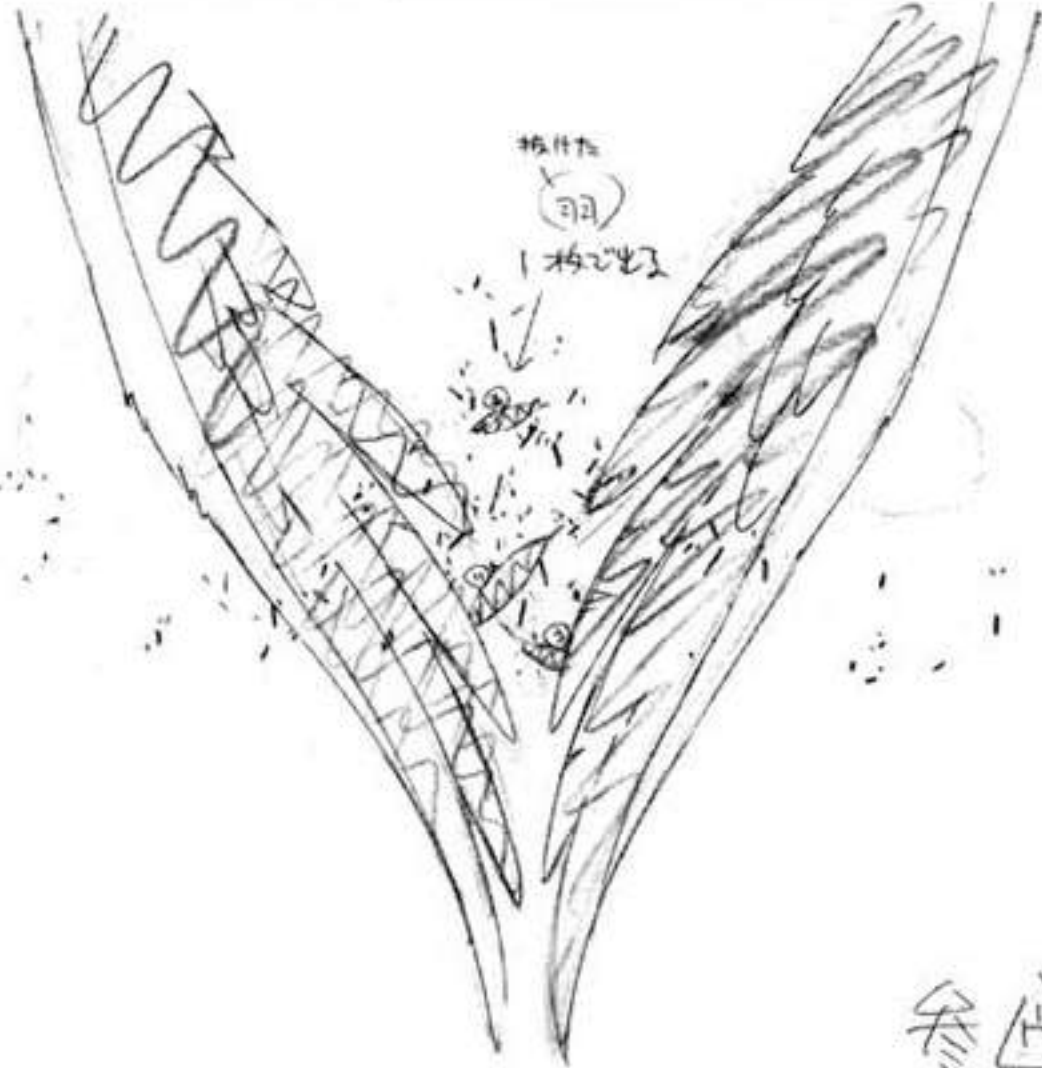

参B

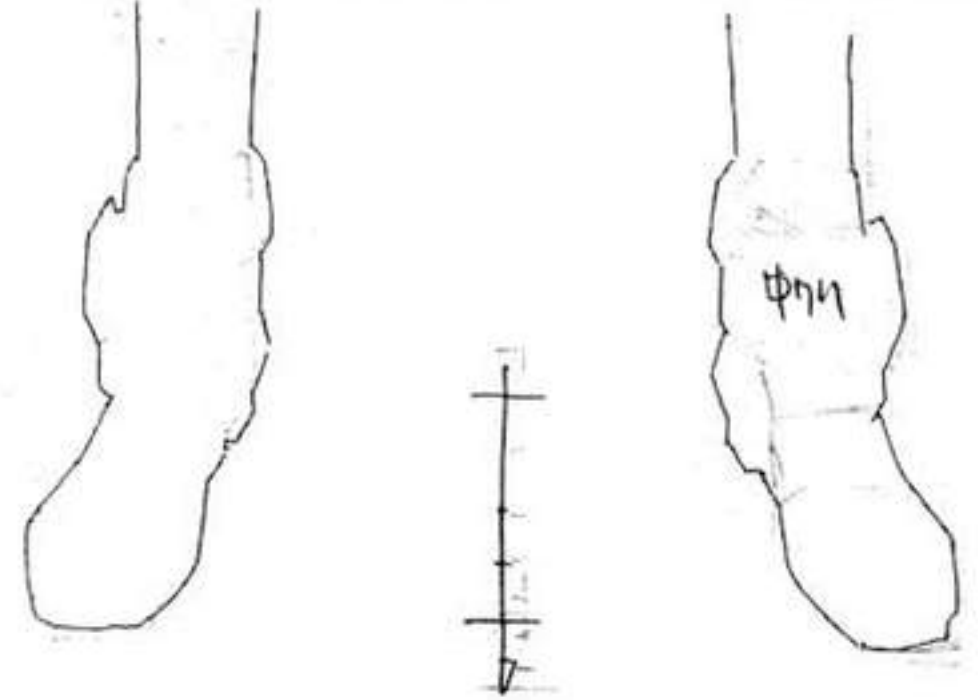

参C

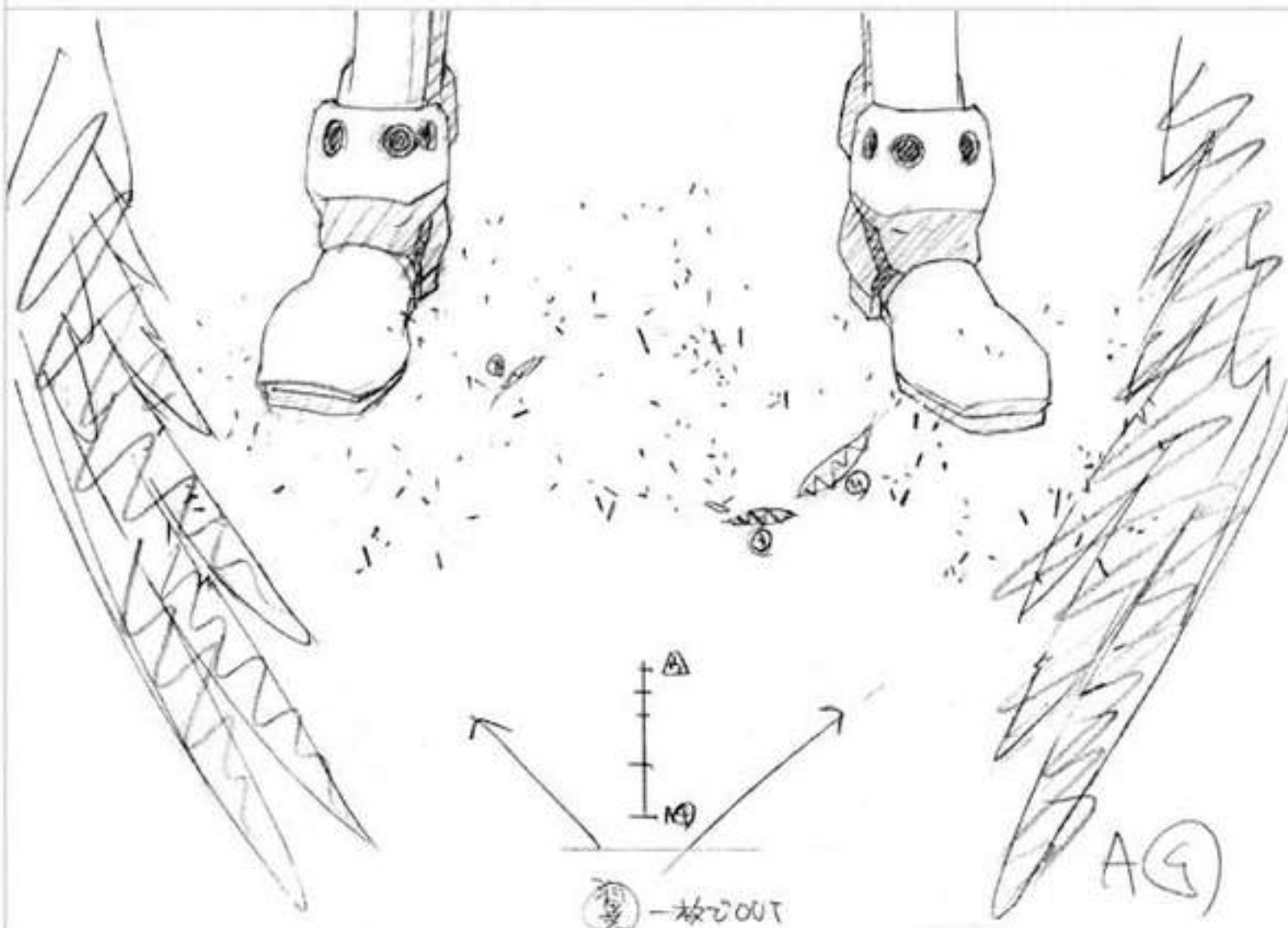

A④

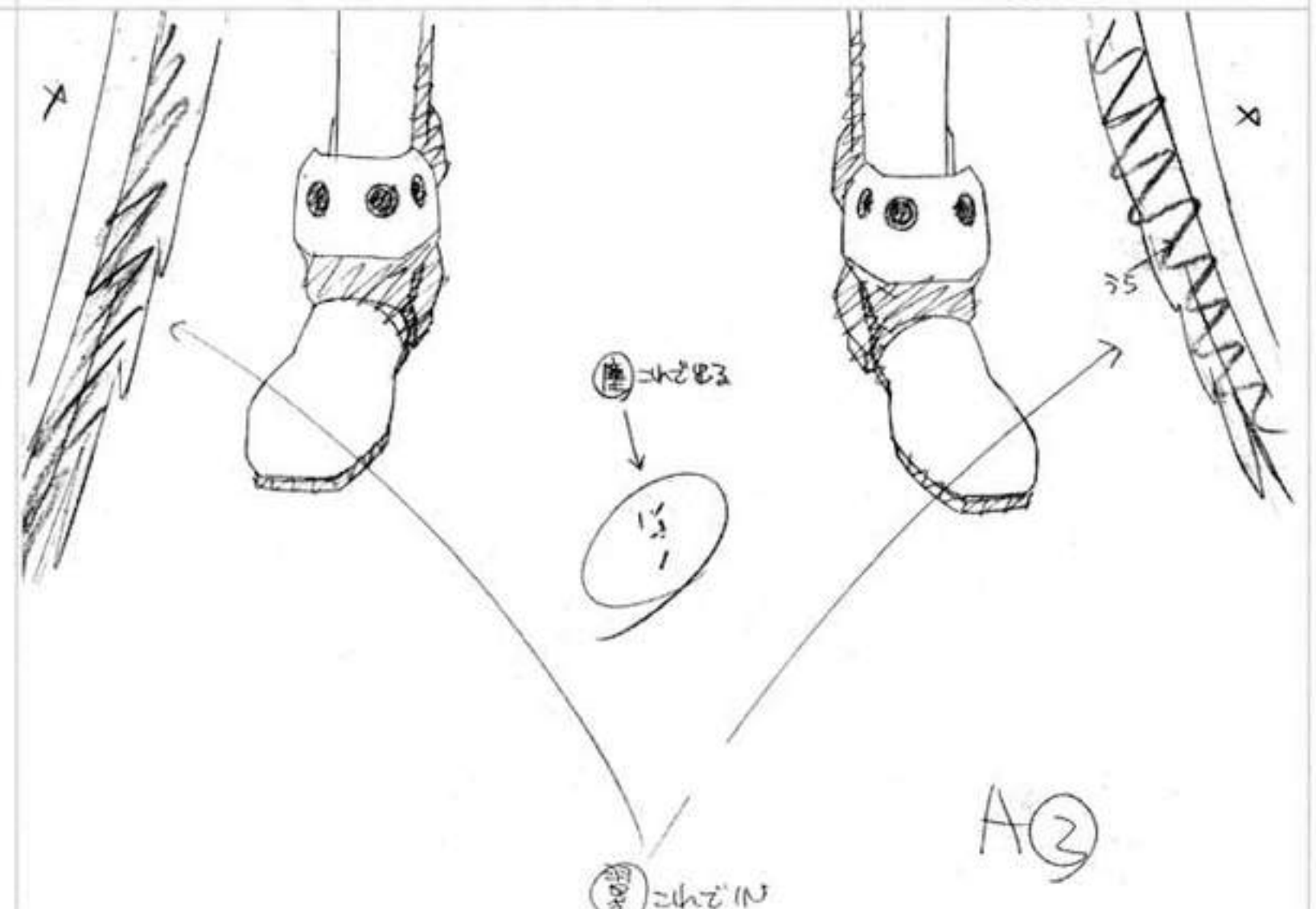

A②

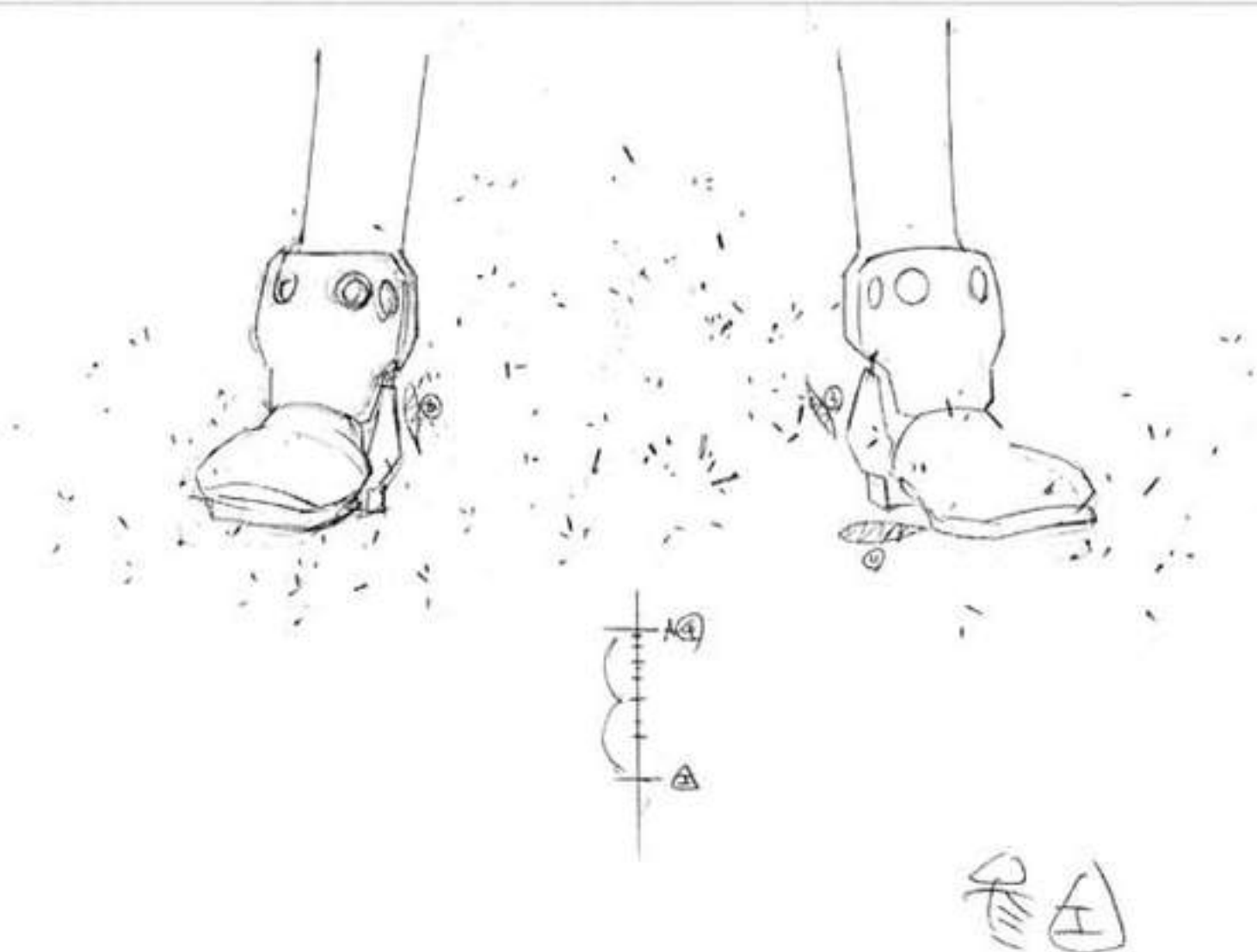

参D

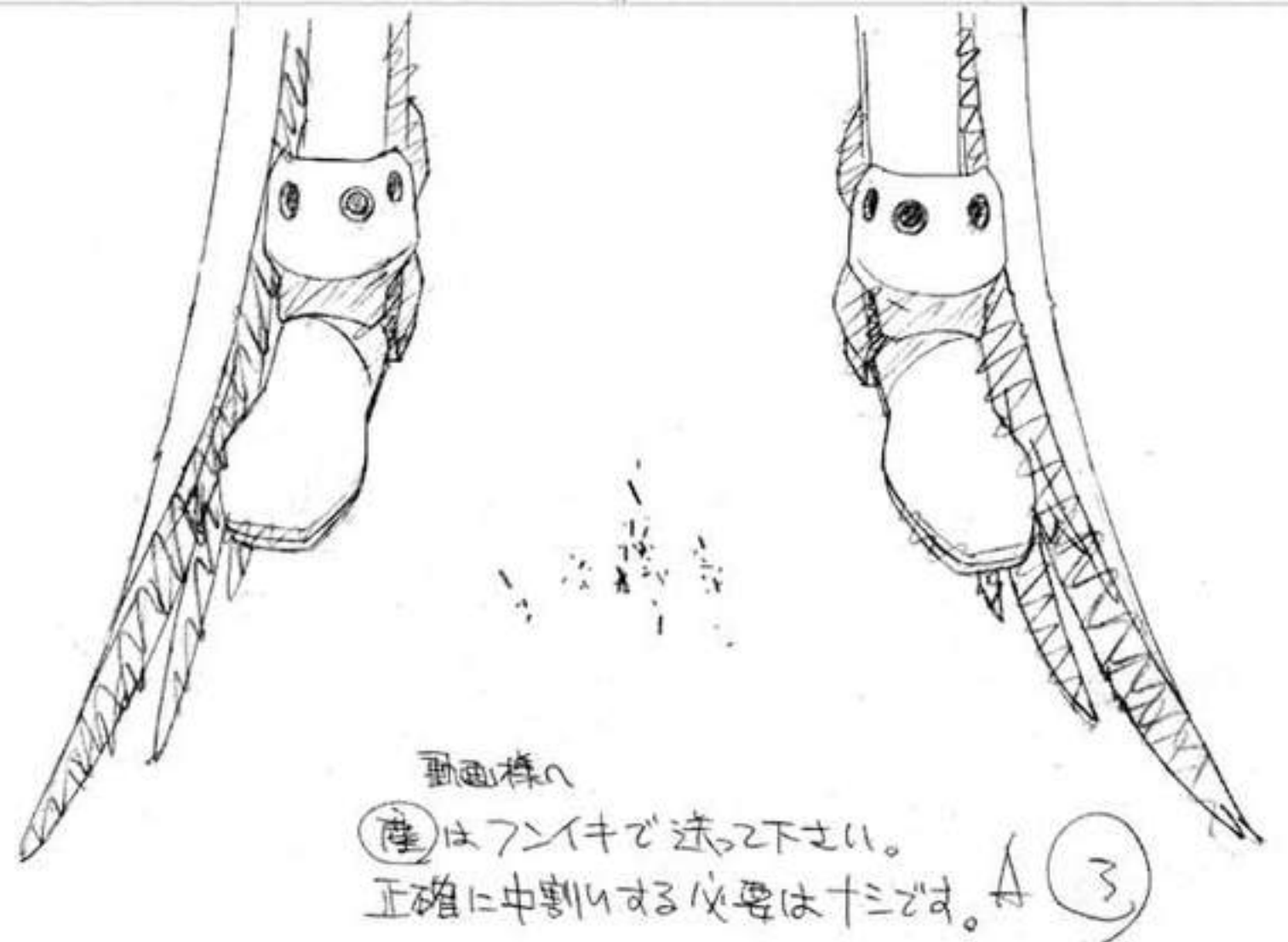

脚の  
⊗ はフニキで迷下さい。  
正確に中割りする必要はナシです。A③







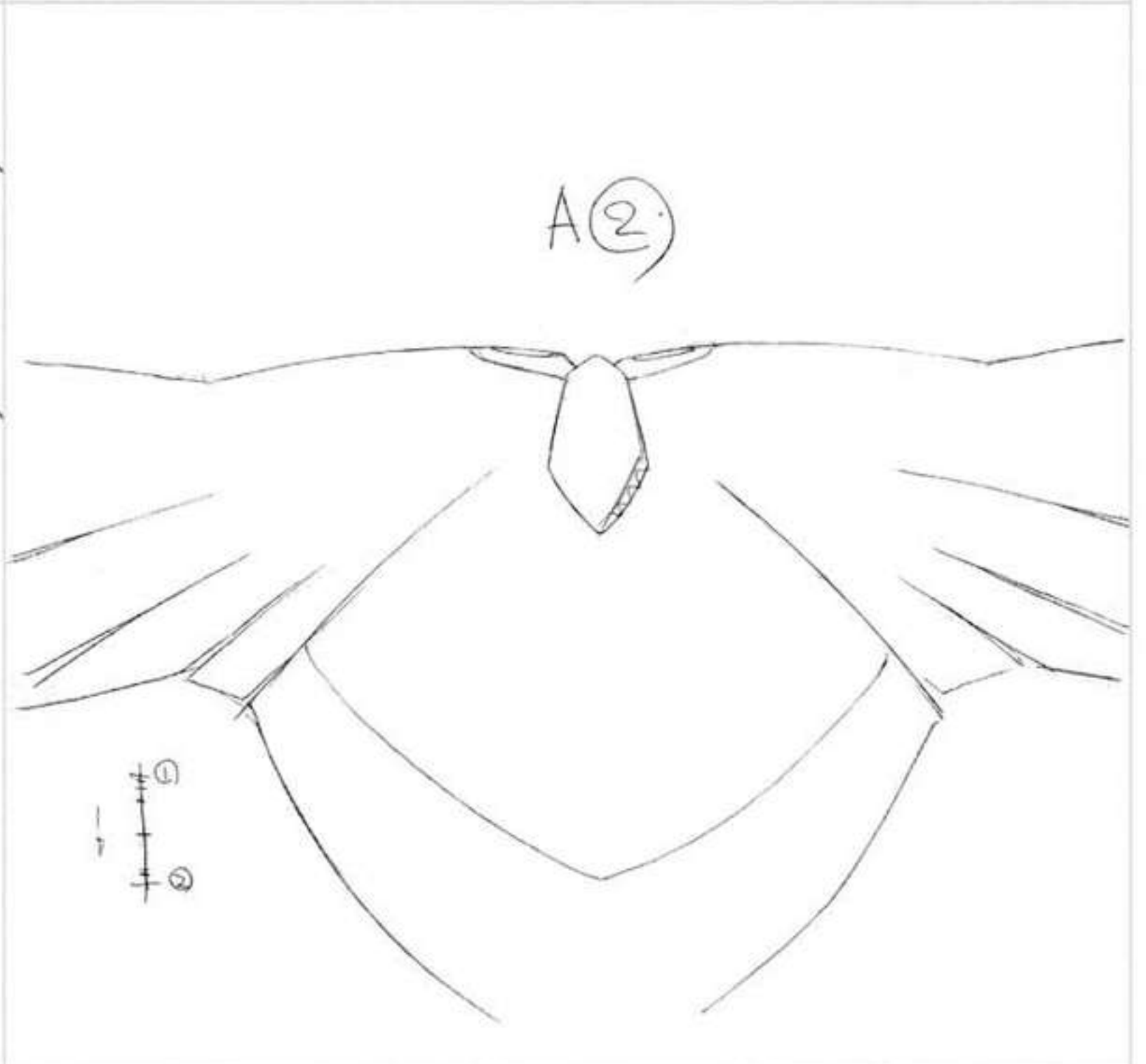
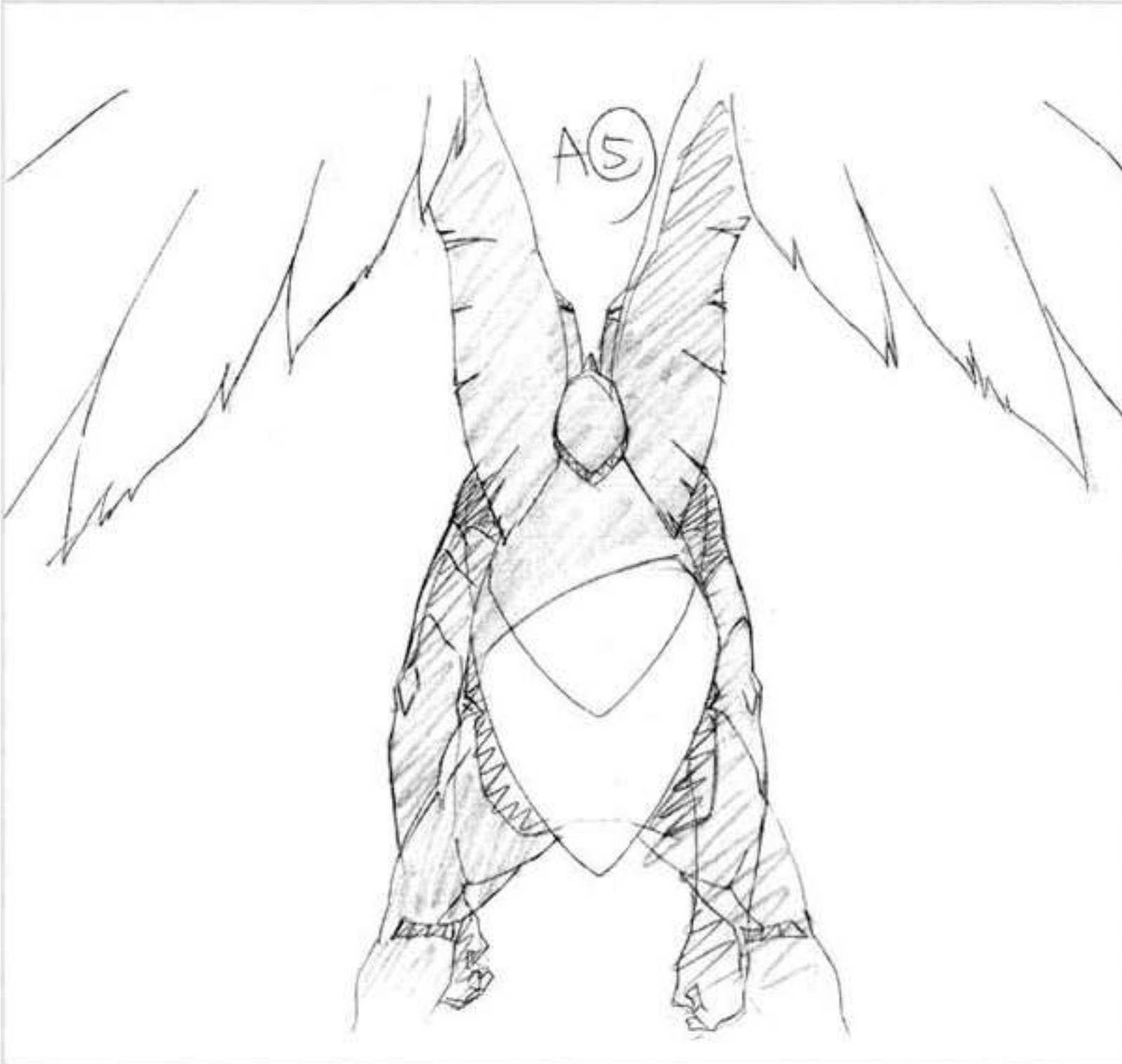
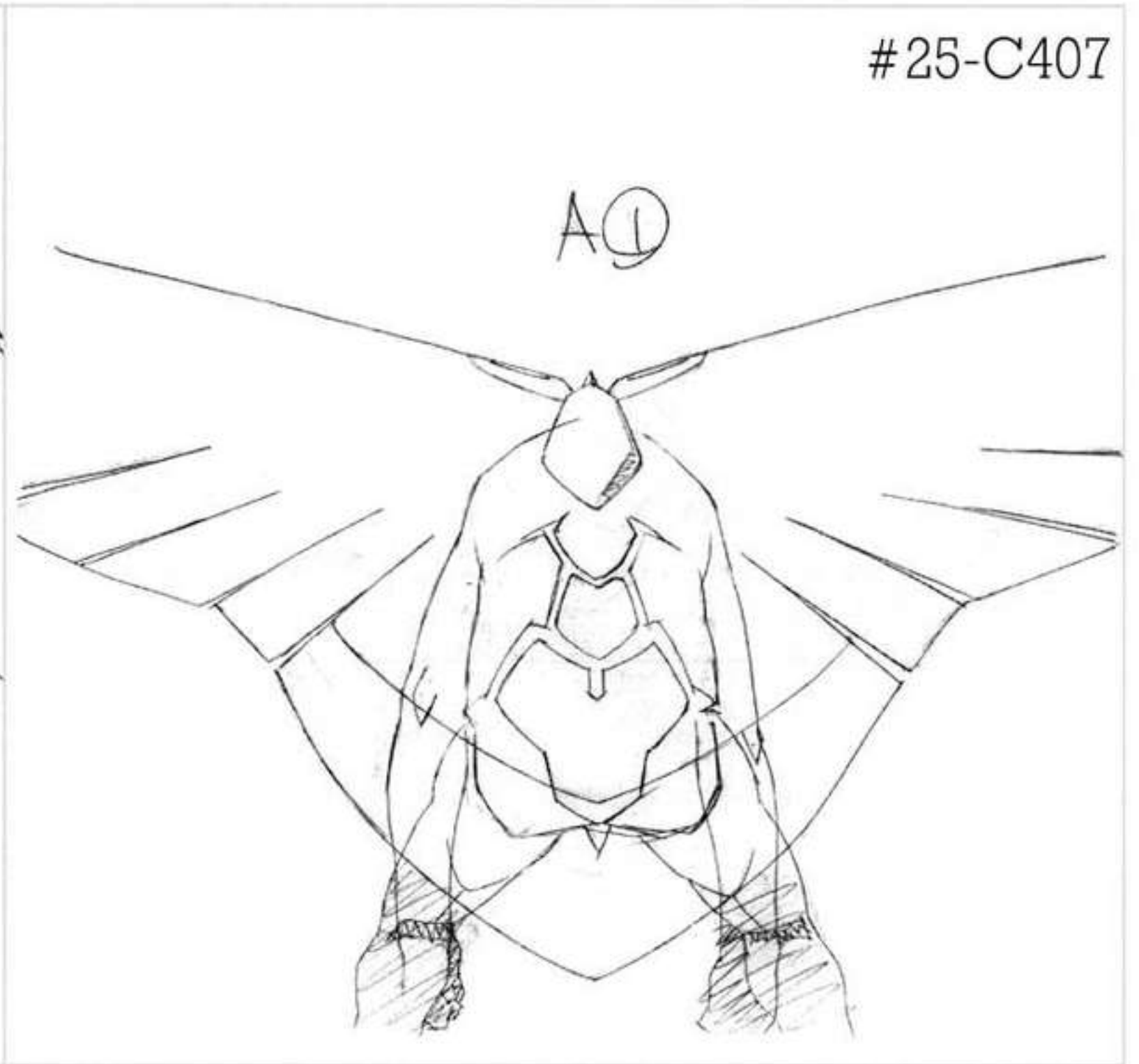



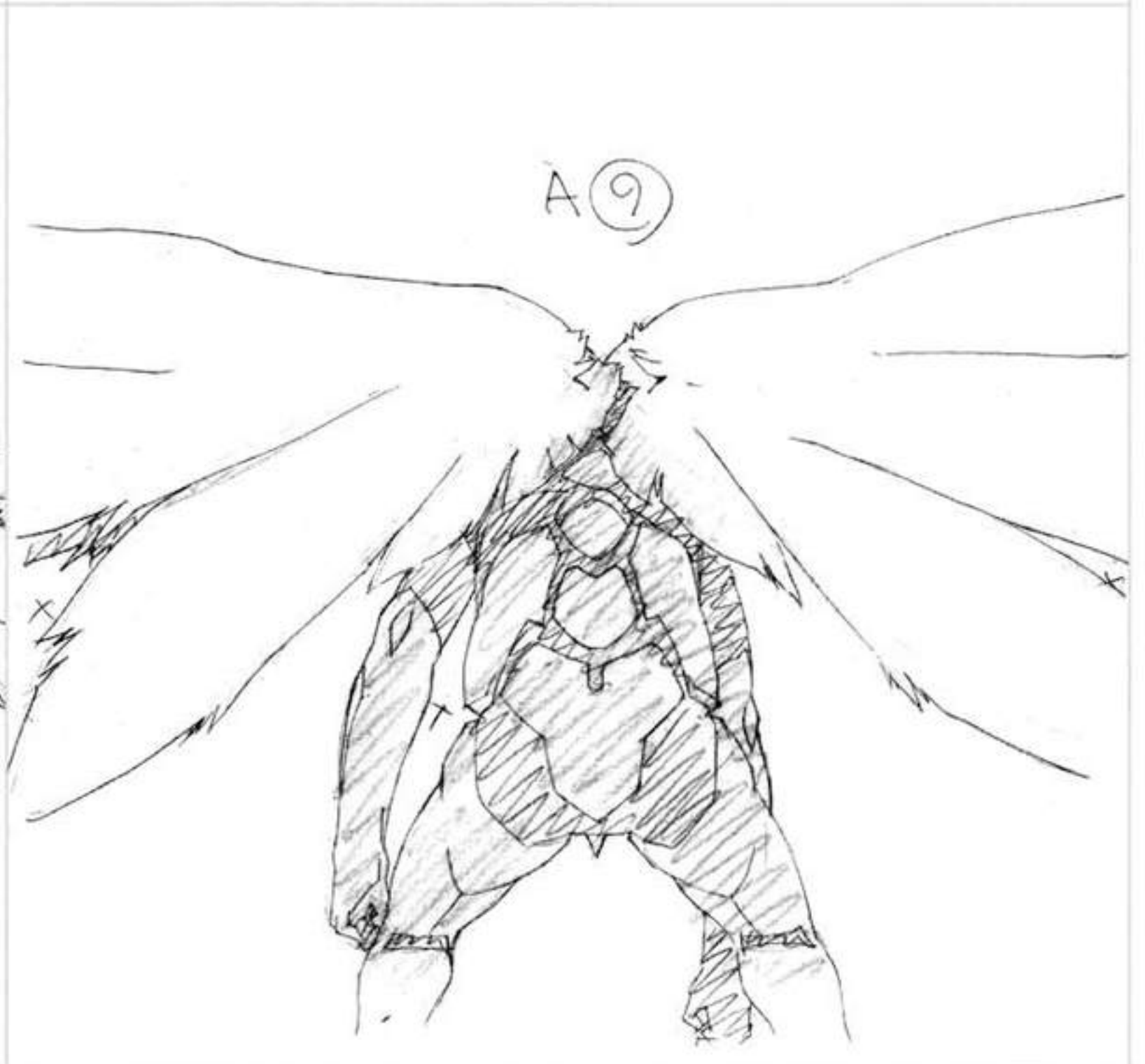
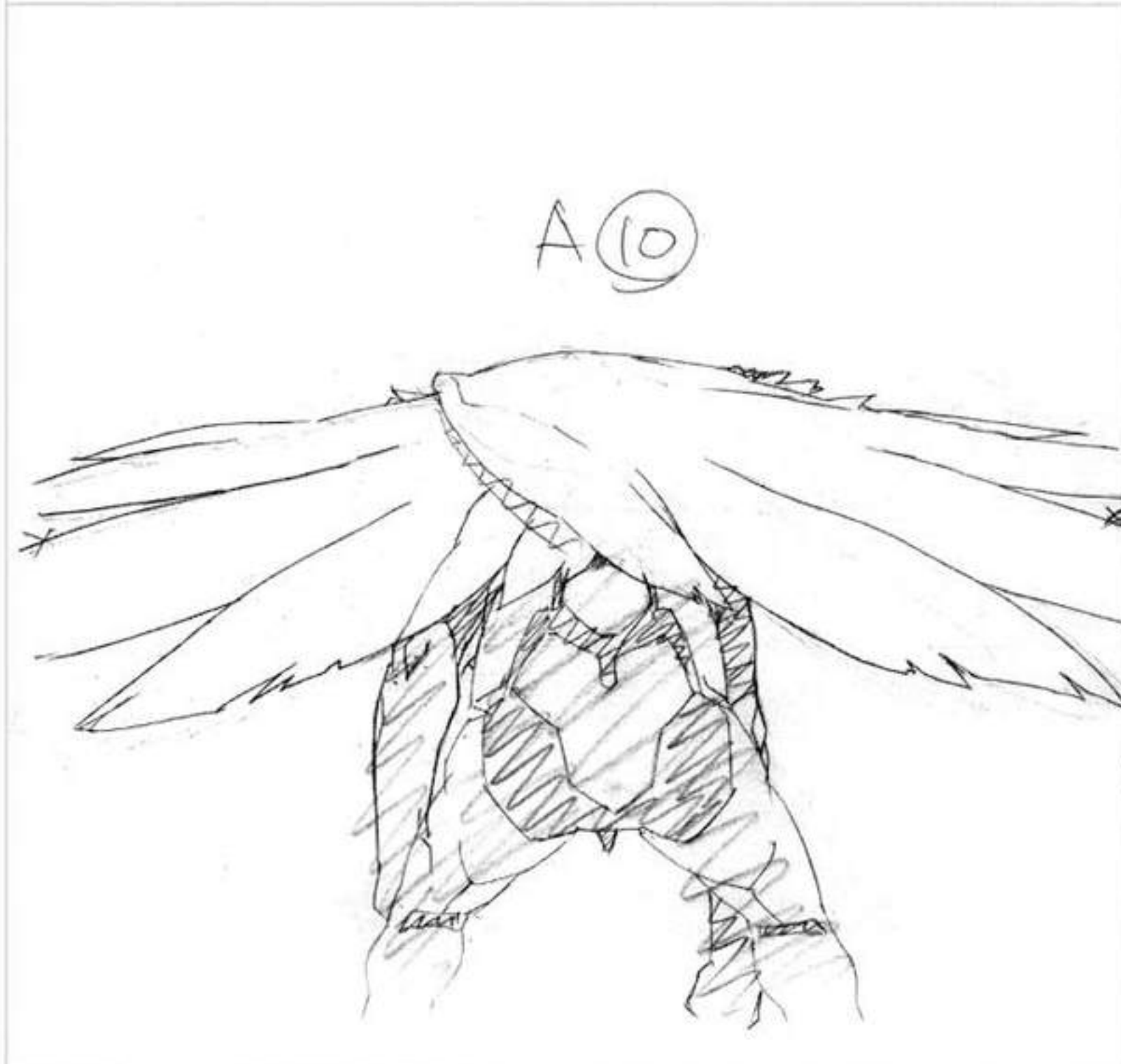
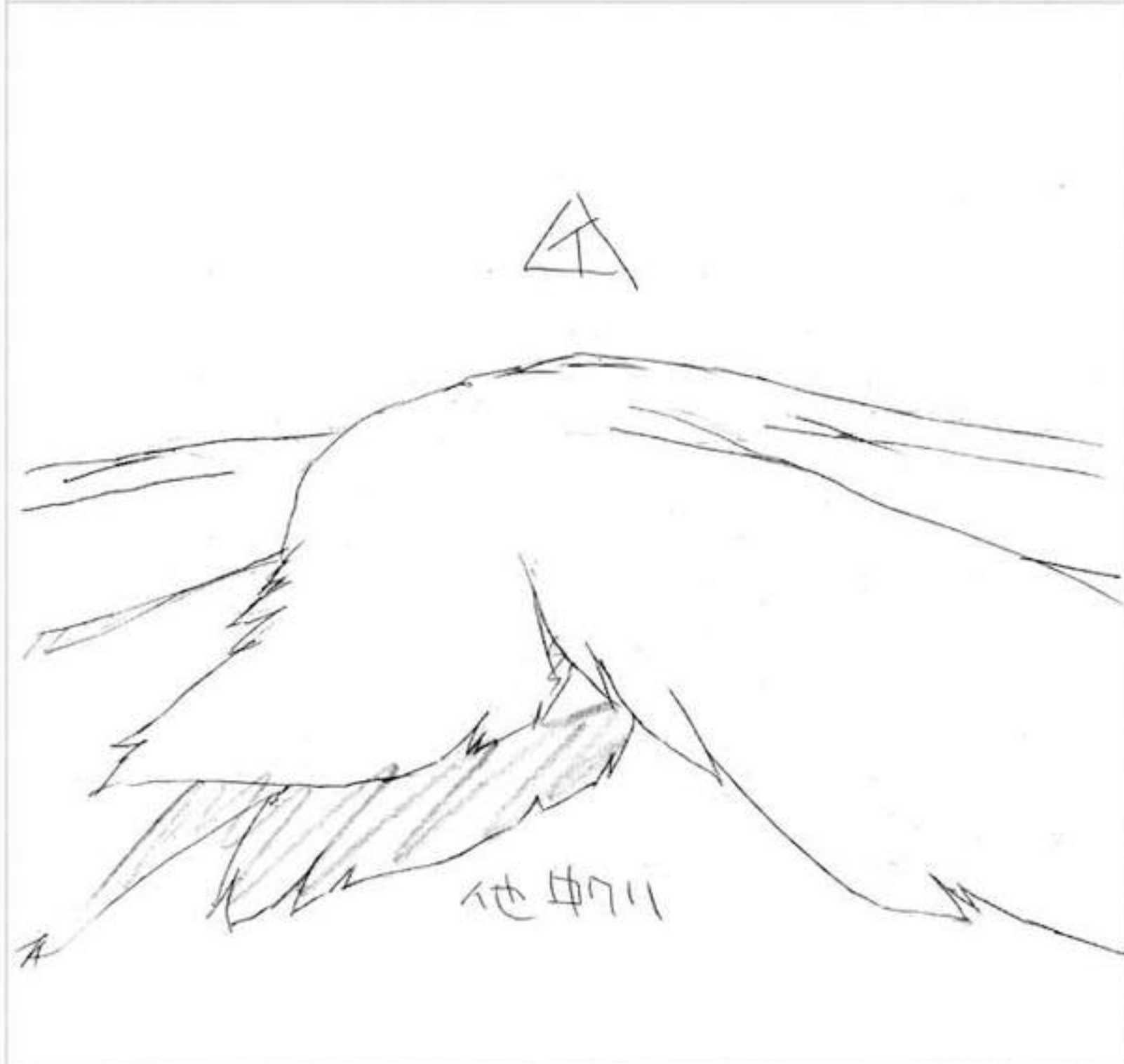
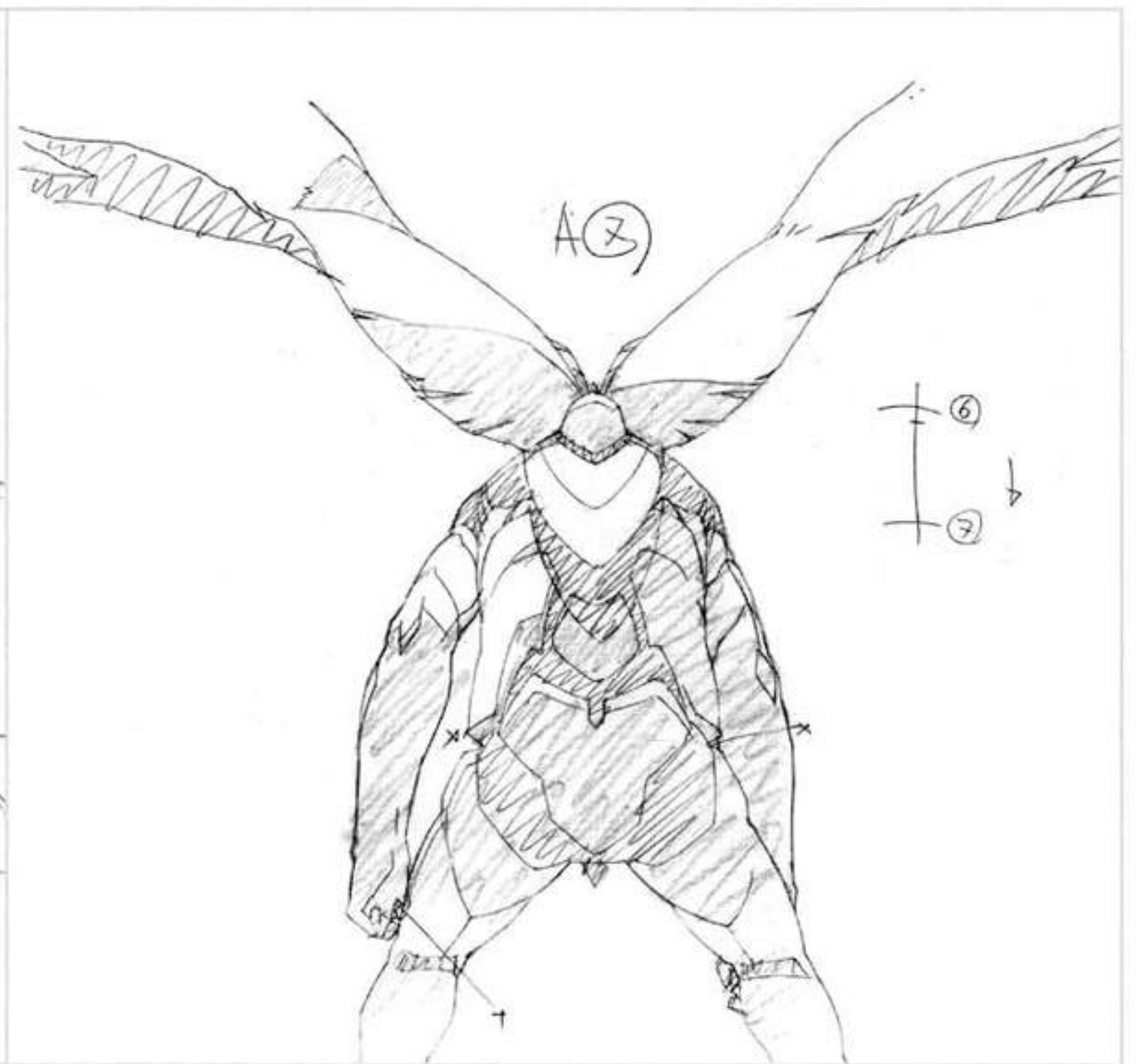
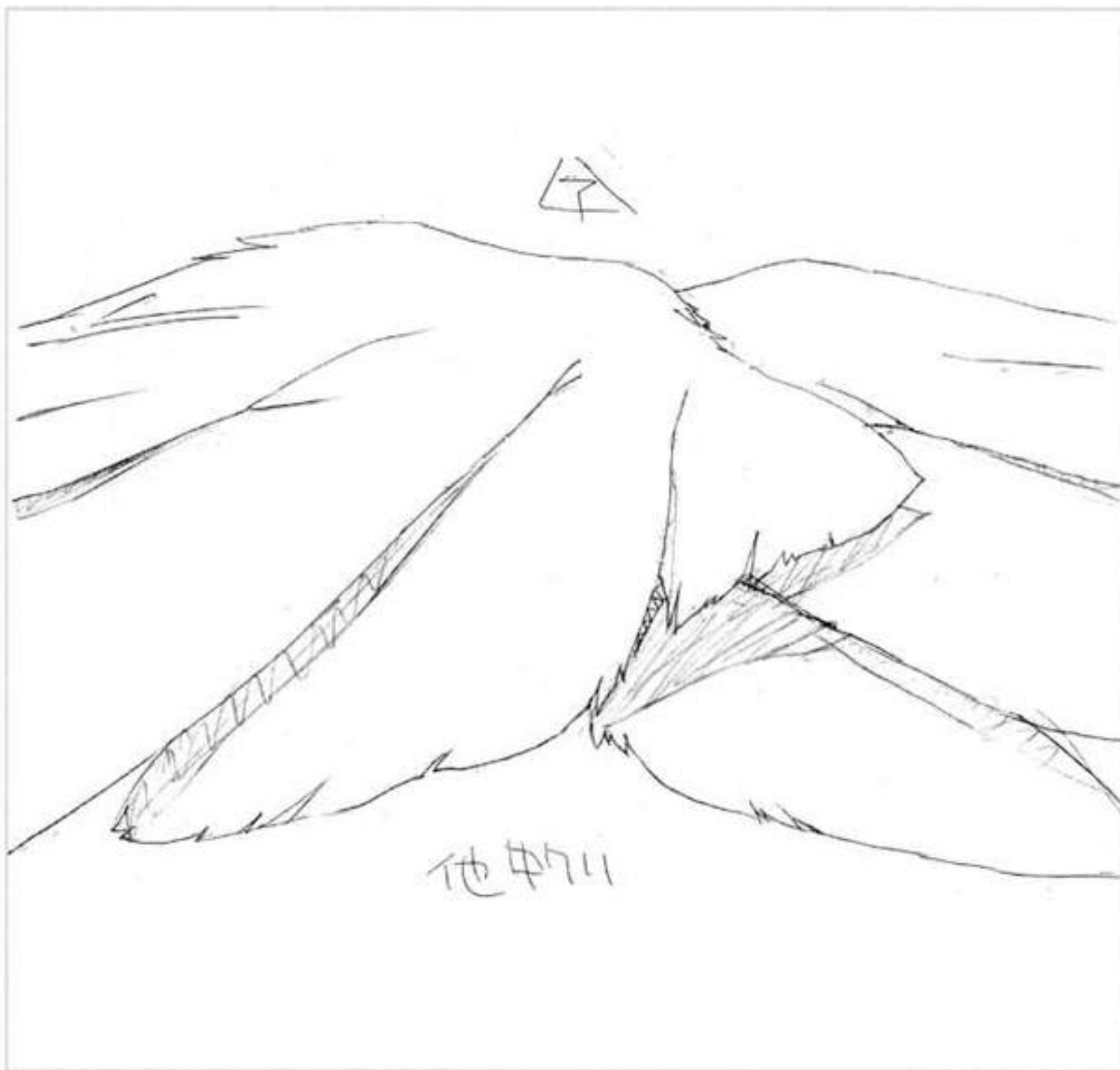



A (12)

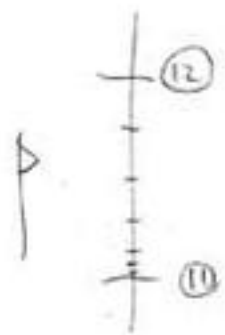

A



#25-C407

タイムシート

A	
①	2
、	4
、	6
、	8
、	10
、	12
②	14
、	16
、	18
③	20
、	22
、	24
④	26
、	28
⑤	30
、	32
、	34
⑥	36
、	38
⑦	40
、	42
、	44
⑧	46
、	48

、	50
、	52
⑨	54
、	56
⑩	58
、	60
、	62
、	64
、	66
⑪	68
、	70
、	72
、	74
⑫	76
、	78
、	80
、	82
、	84
、	86
、	88
⑬	90
、	92
、	94
⑭	96

A (11)



A (13) END



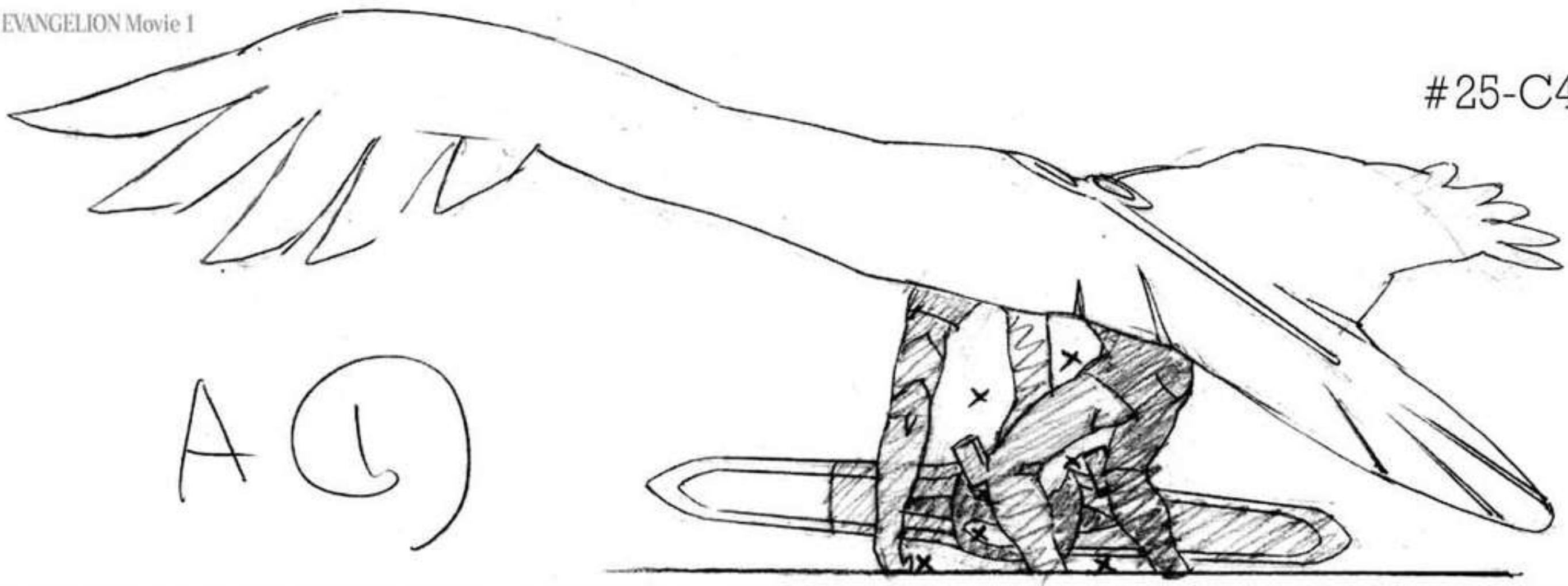

A ⑥

羽根は鳥の骨



A ②

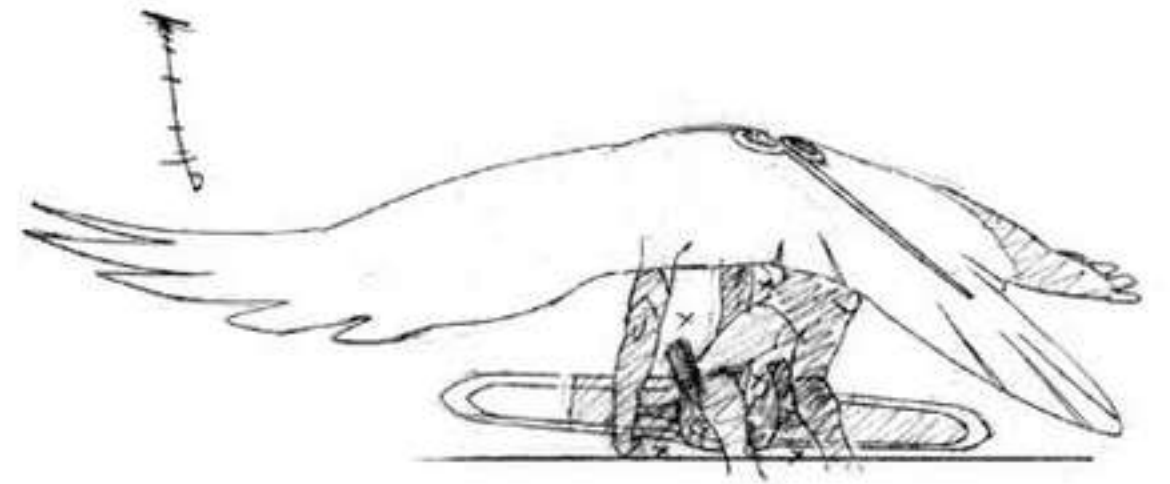

A ⑦

羽根は鳥の骨



A ③

③  
②

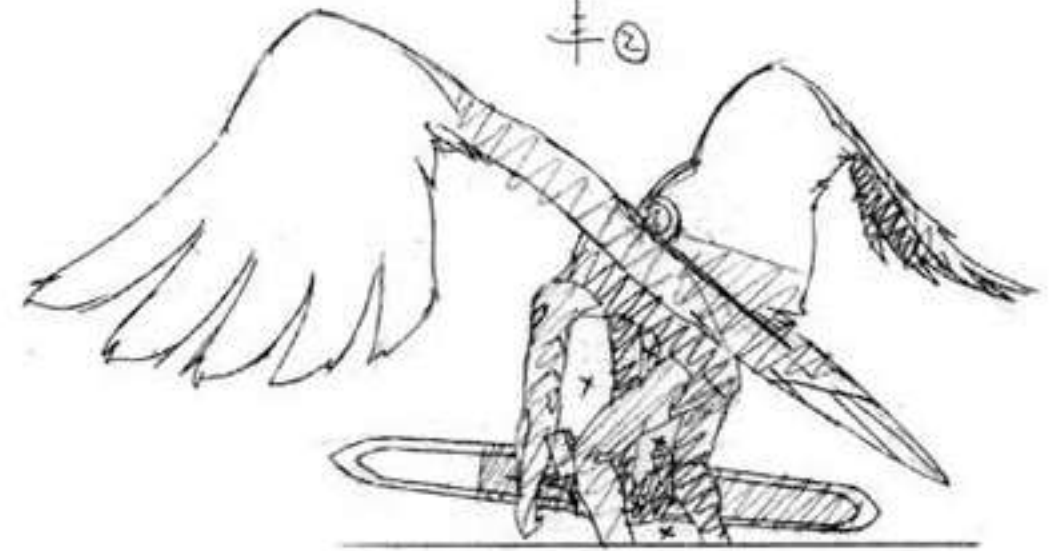

A ⑧



A ④

③  
④

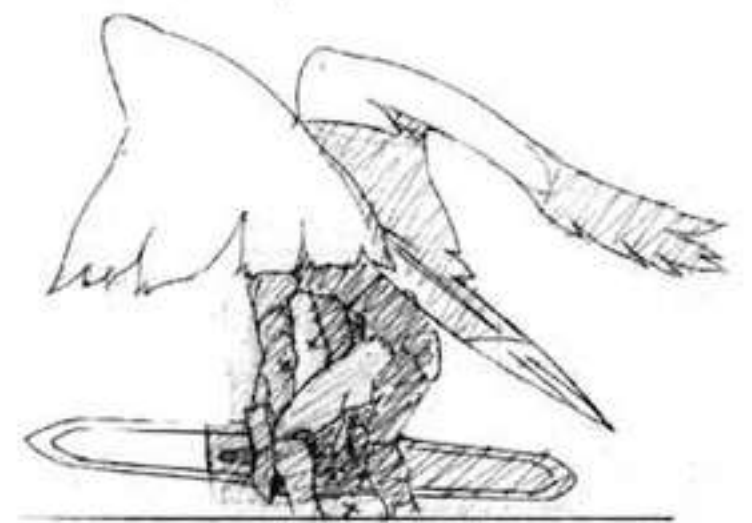

A ⑨ END

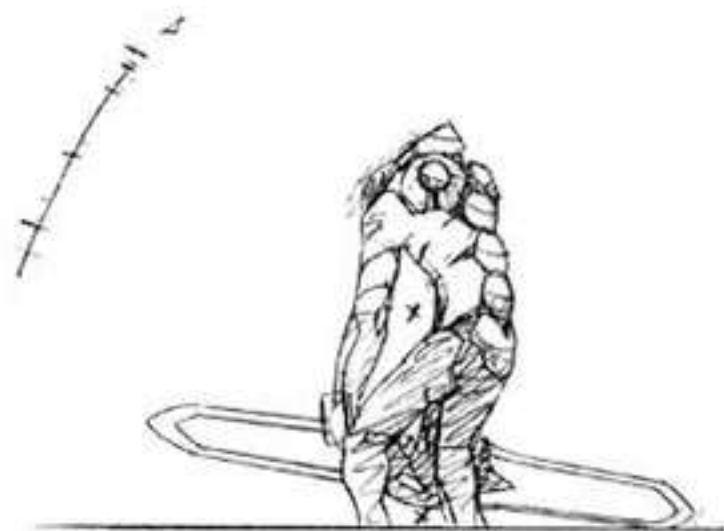

A ⑤

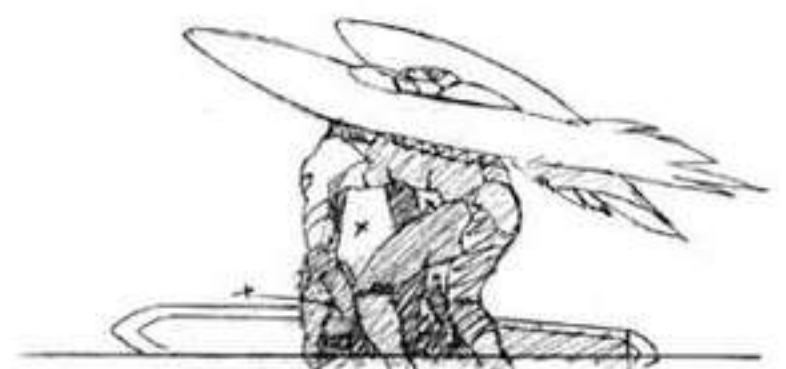



B(1)

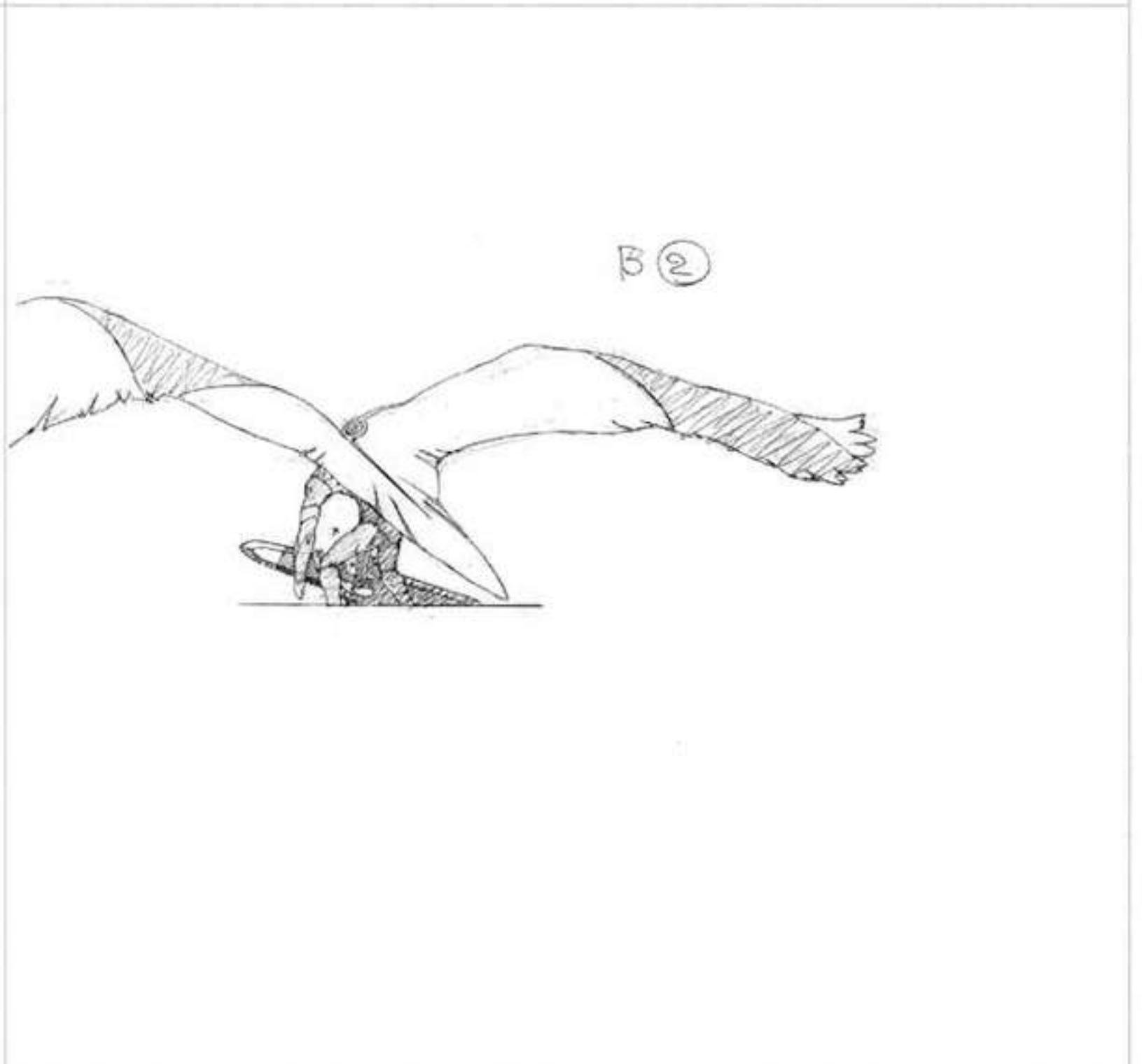
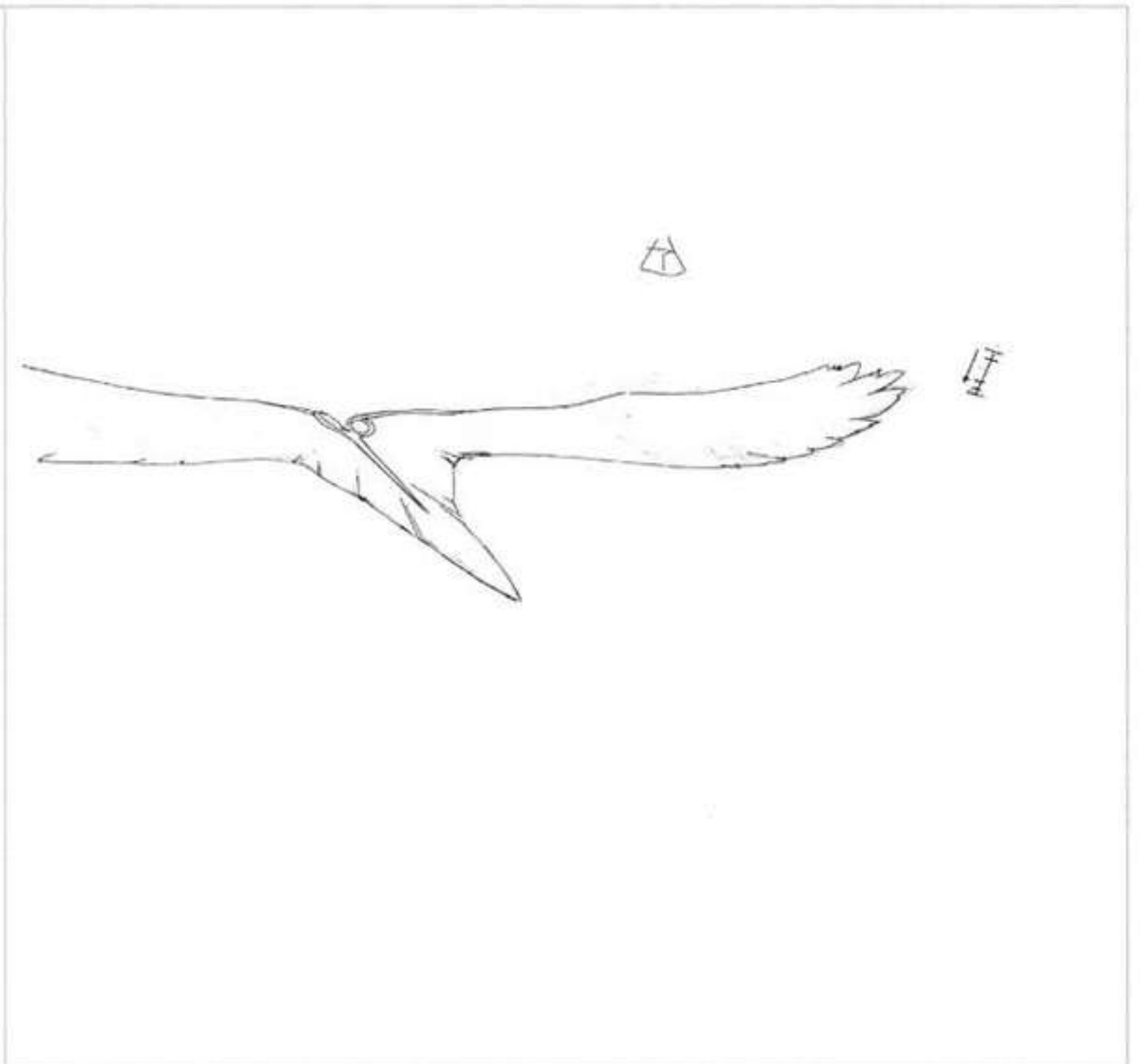
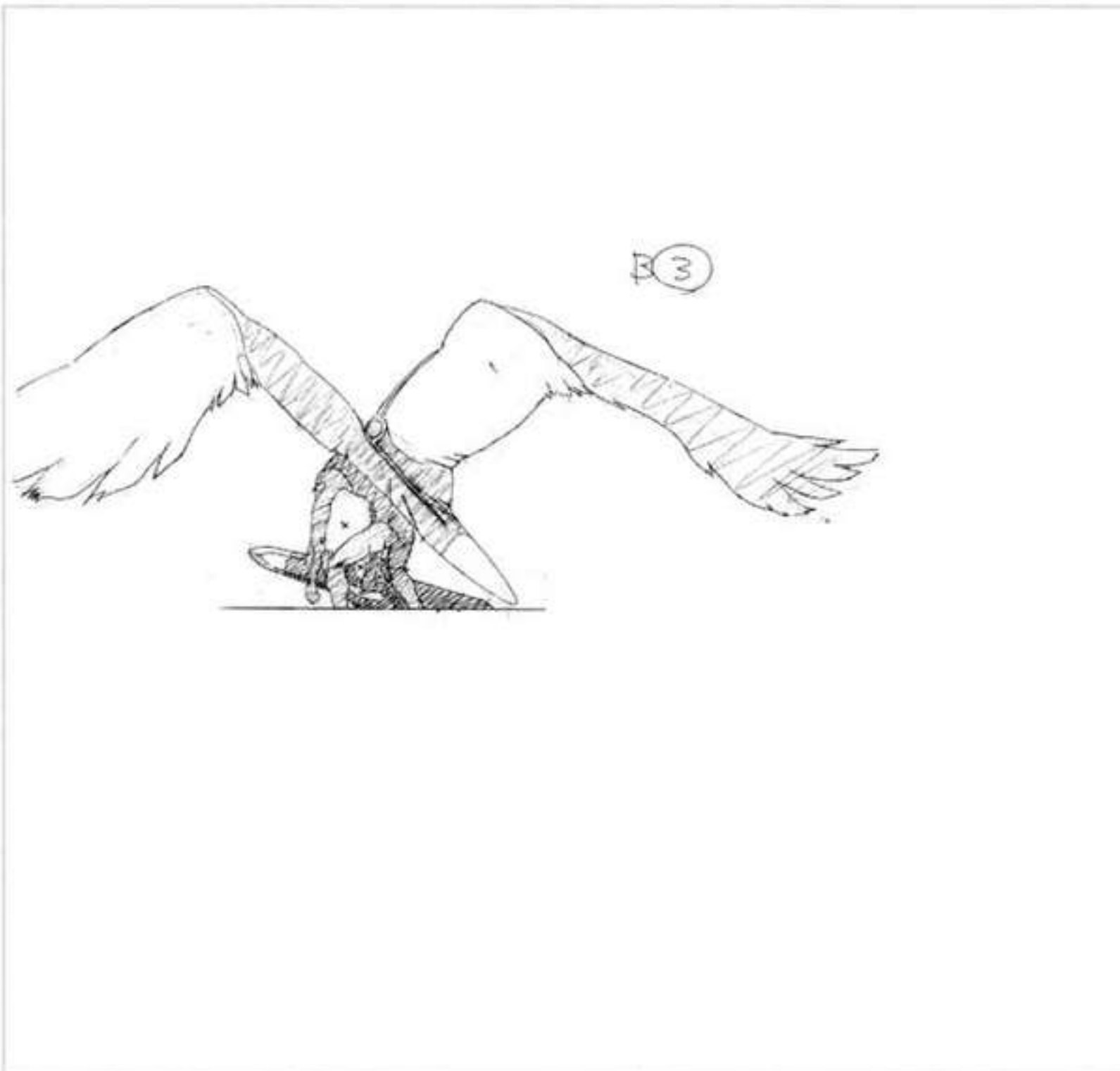
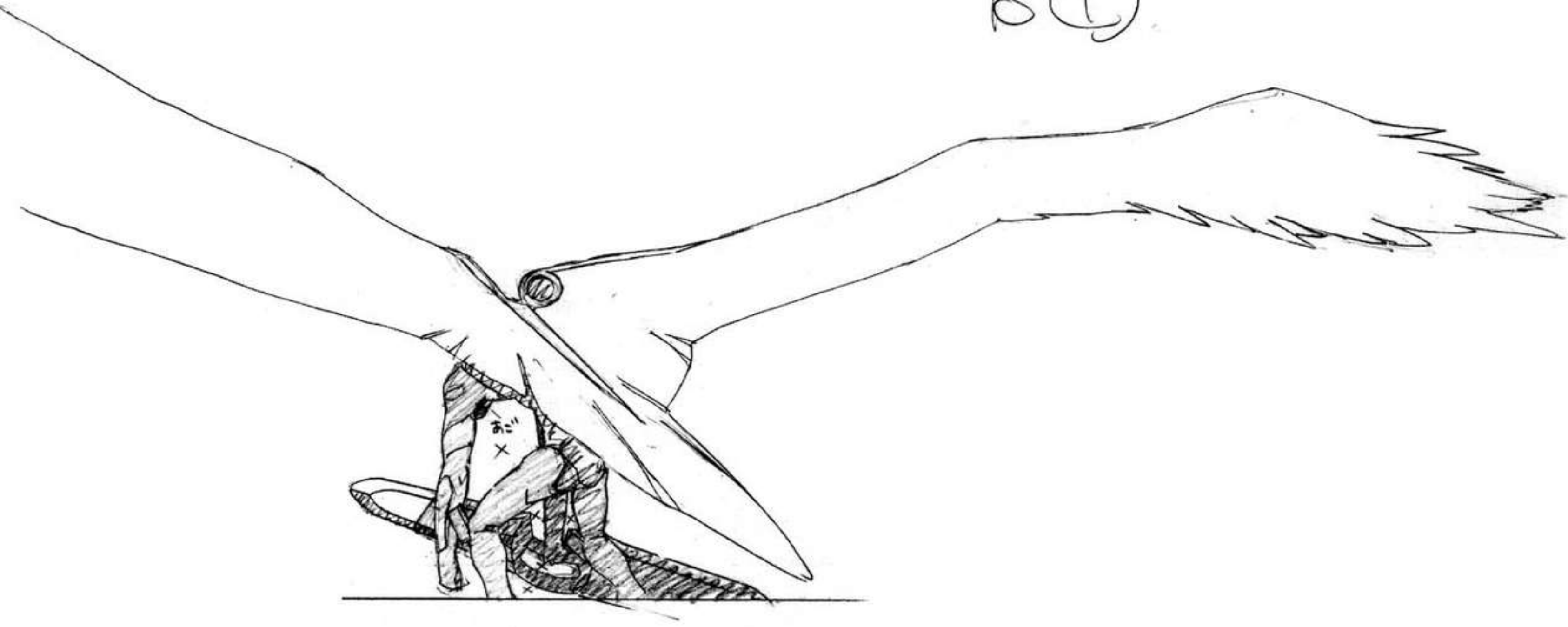



B(6)



B(4)

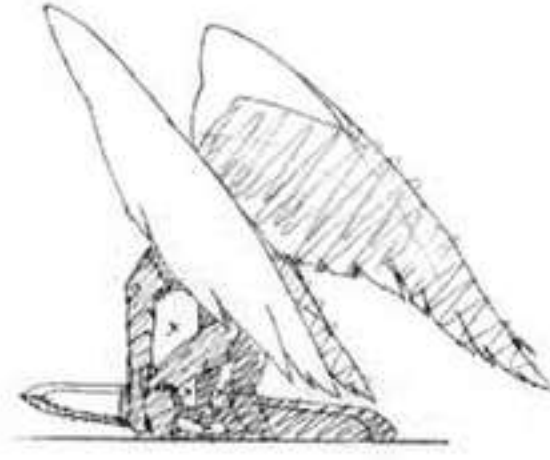

B(7)

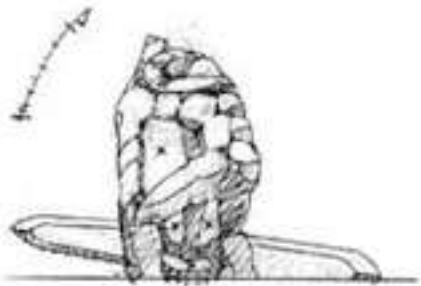

B(5)



#25-C408

B (8) END

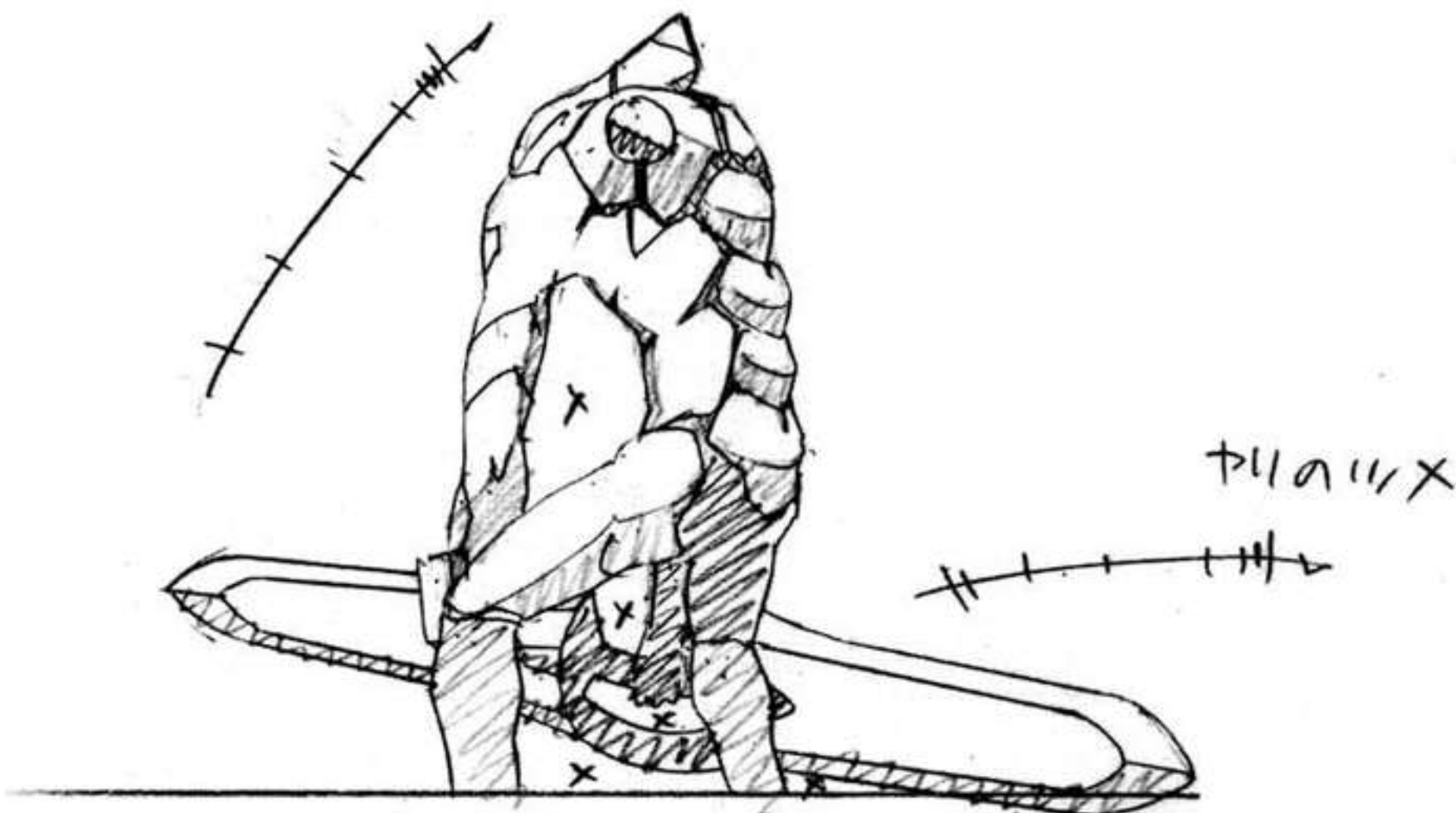

タイムシート

A	B				
①	①	2	\	\	32
		4	\	\	34
		6	\	\	36
		8	\	\	38
		10	\	\	40
		12	\	\	42
		14	\	\	44
		16	\	\	46
		18	\	\	48
		20	\	\	50
		22	\	\	52
		24	\	\	54
		26	\	\	56
		28	\	\	58
		30	\	\	60
			\	\	62
			\	\	64
			\	\	66
			\	\	68
			\	\	70
			\	\	72
			\	\	74
			\	\	76
			\	\	78
			\	\	80
			\	\	82
			\	\	84
			\	\	86
			\	\	88
			\	\	90
			\	\	92
			\	\	94
			\	\	96
			\	\	98
			\	\	100
			\	\	102
			\	\	104
			\	\	106
			\	\	108
			\	\	110
			\	\	112
			\	\	114
			\	\	116
			\	\	118
			\	\	120



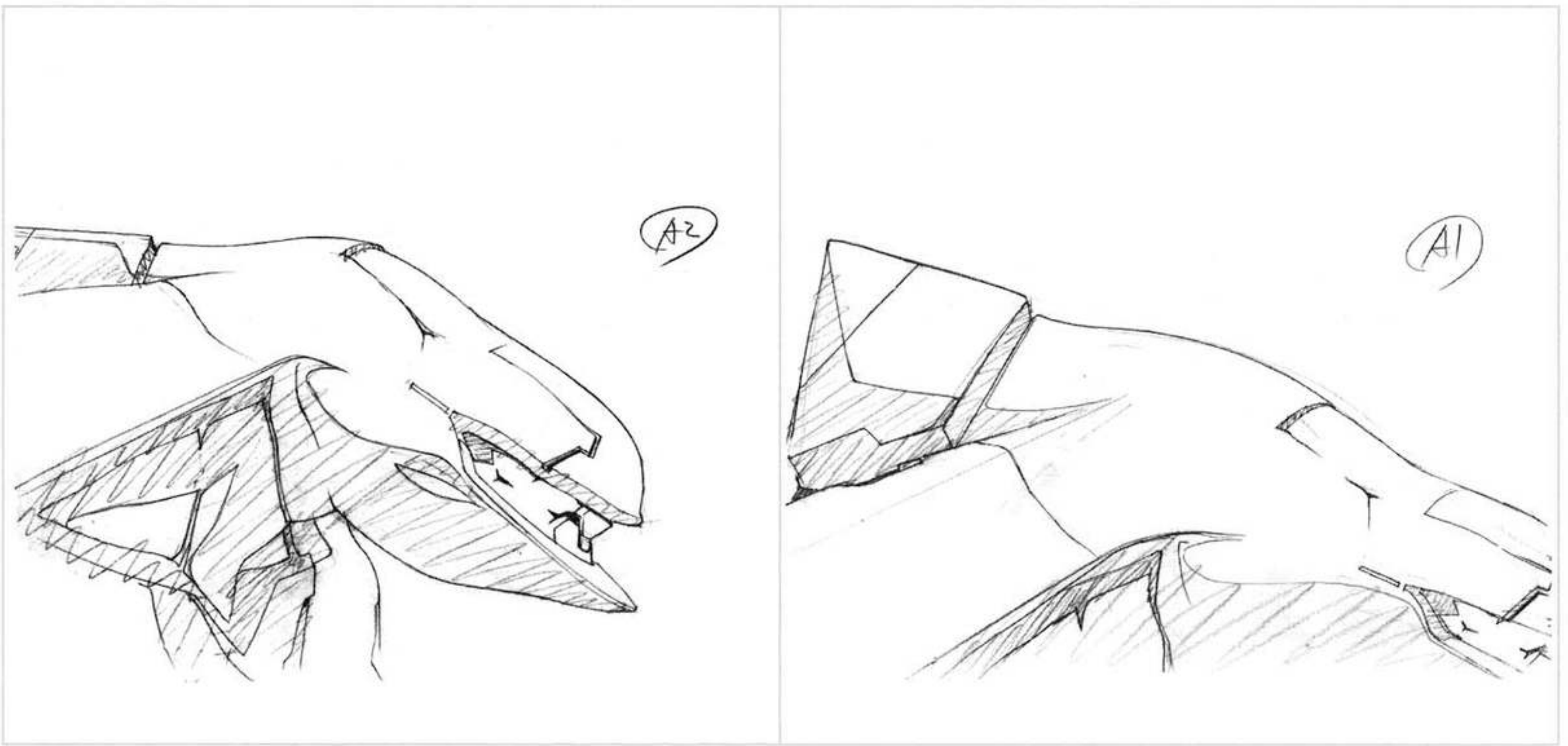

#25-C409

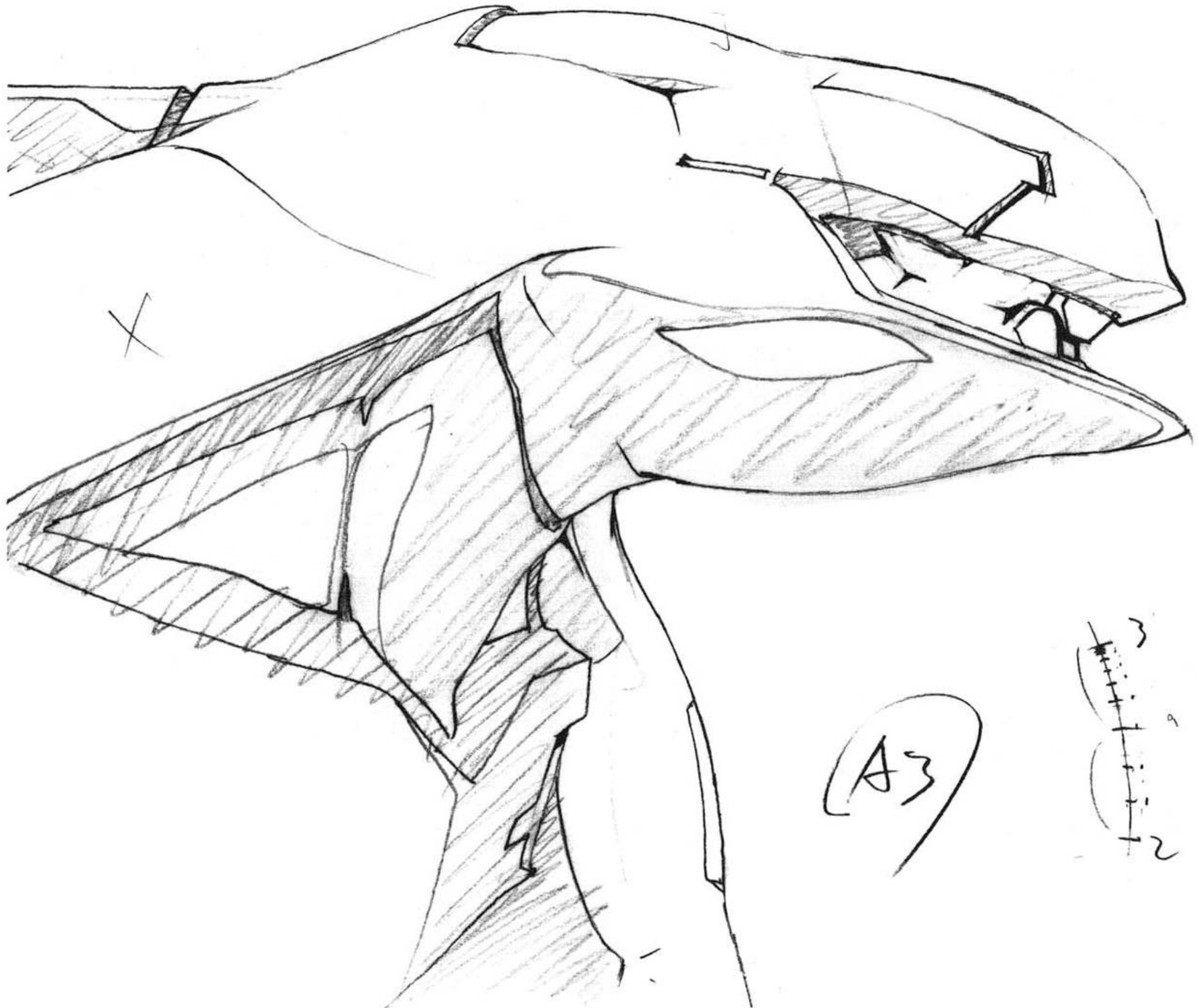





#25-C417

修正原画



B-147  
C-317  
原画と39  
207  
D3  
4  
5



#25-C419



修正原画



修正原画



修正原画



修正原画







修正原画





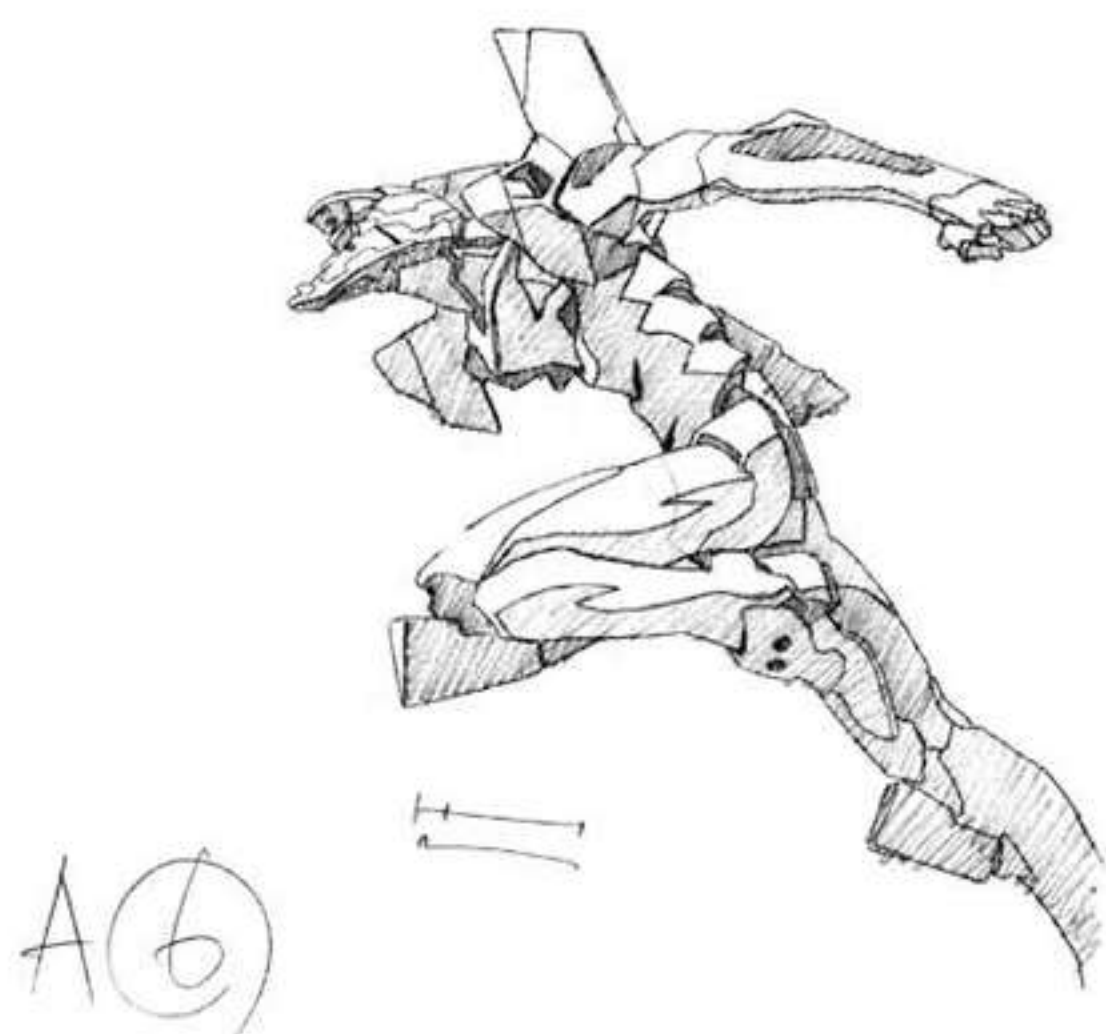
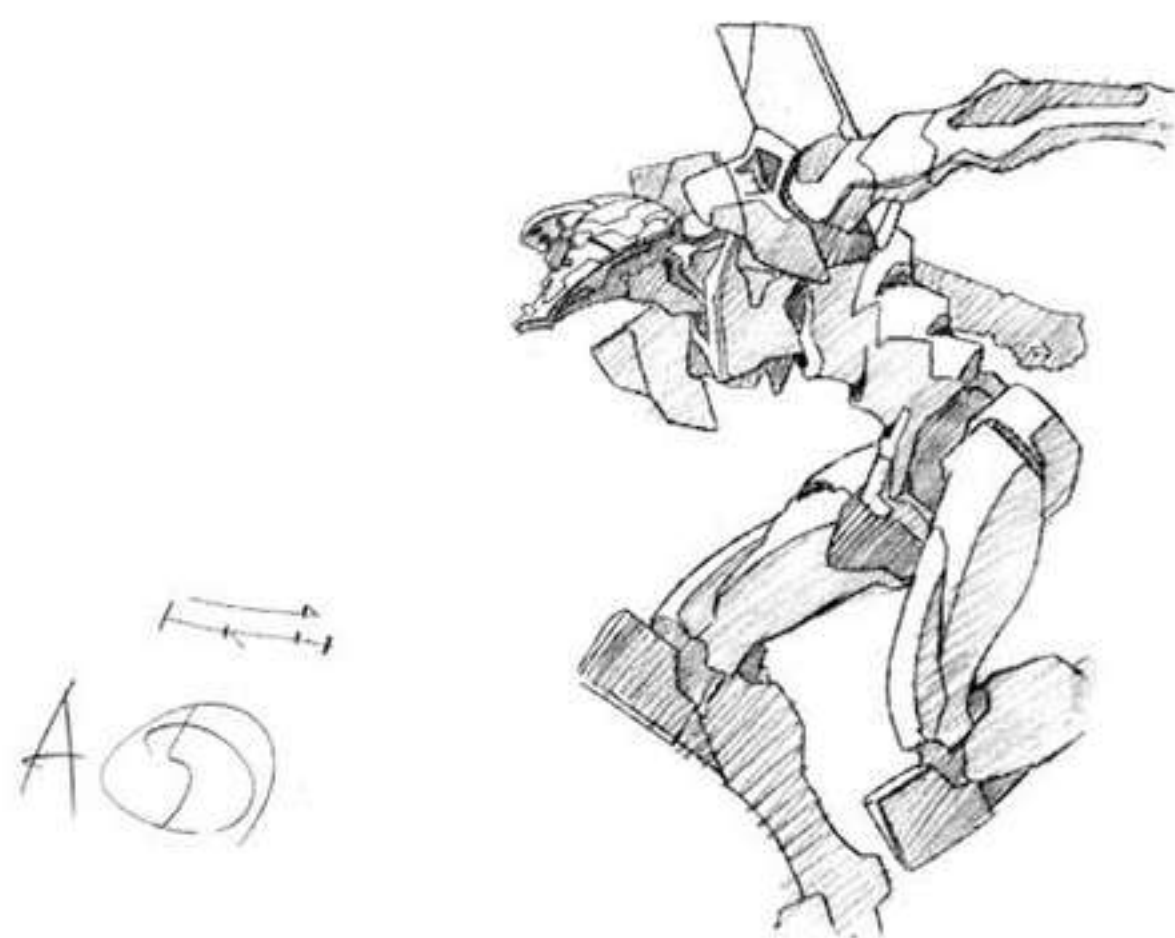
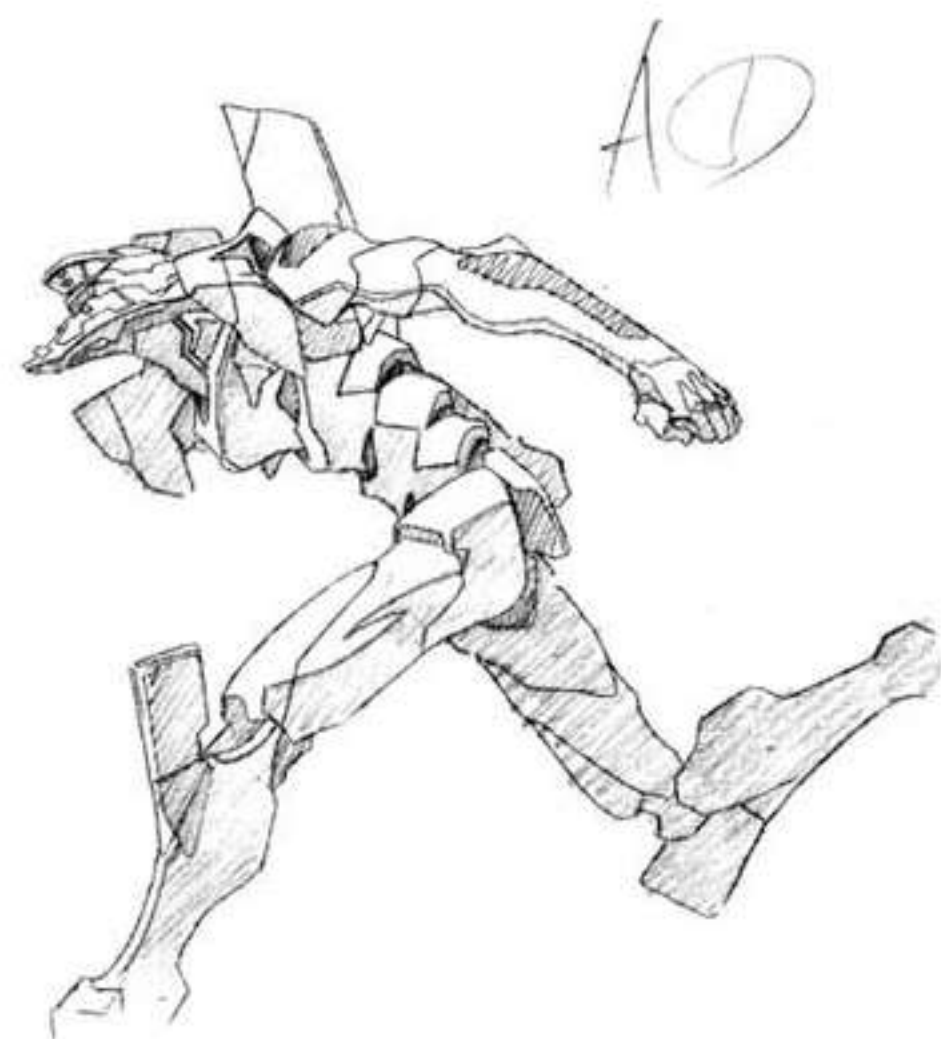



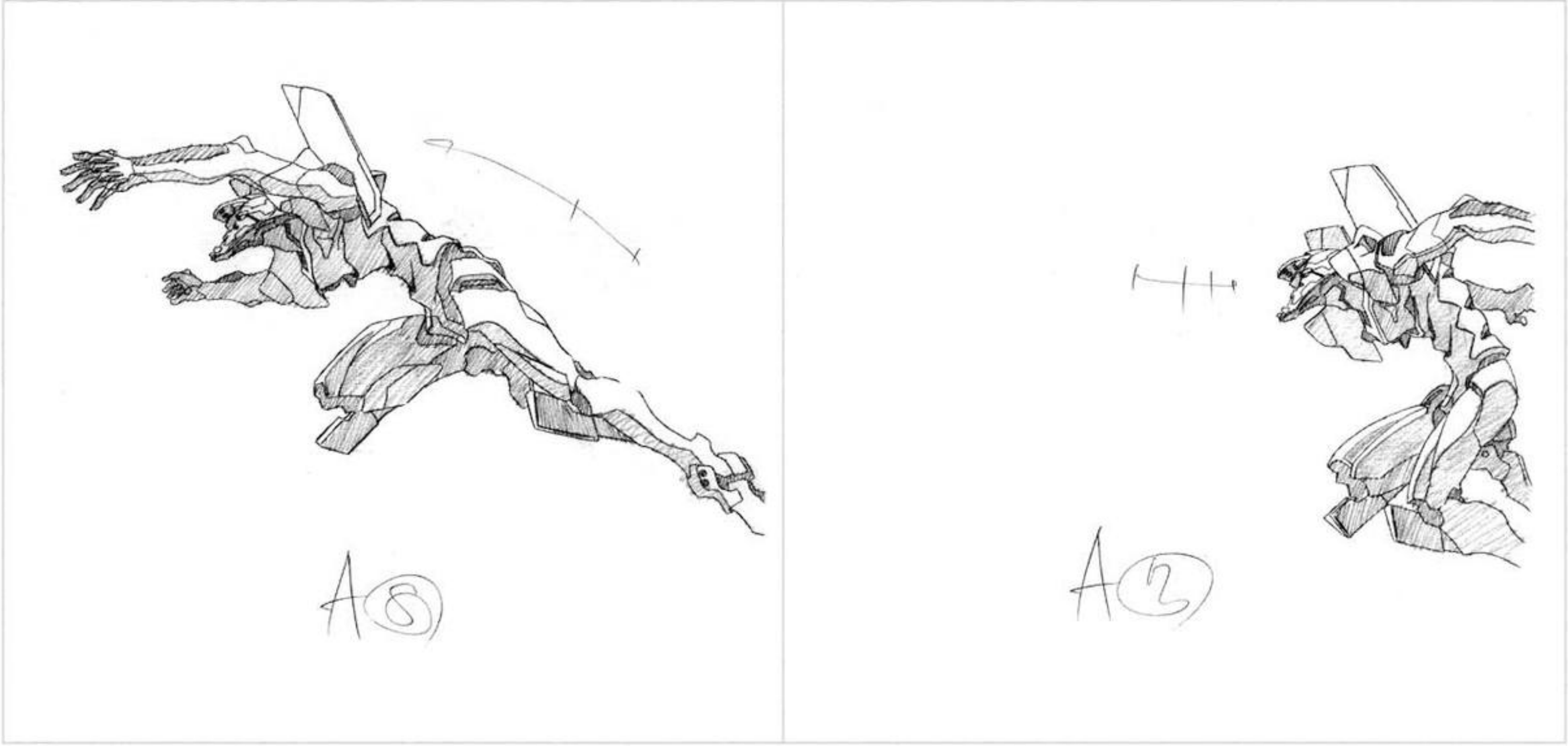



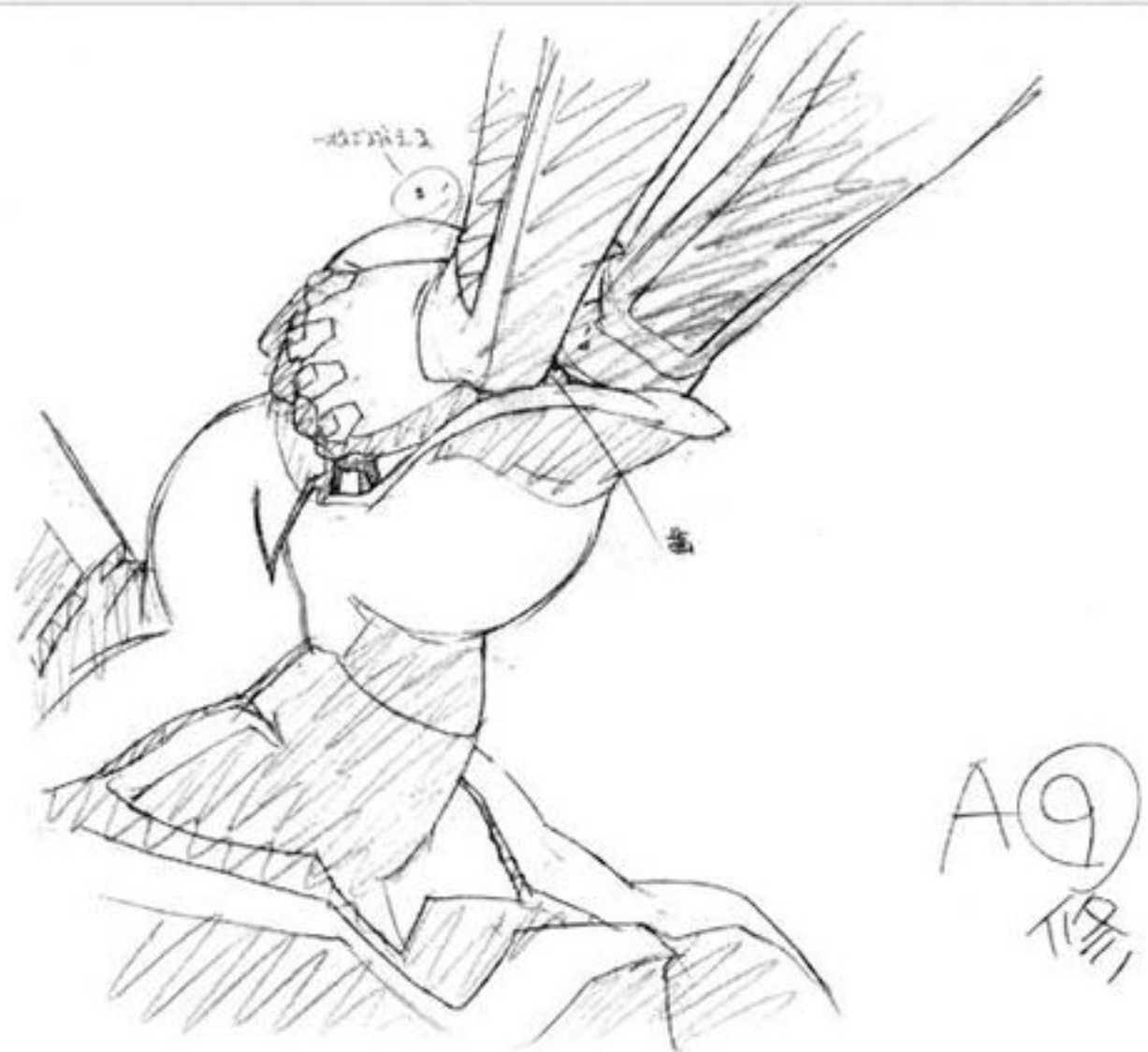

A(9) 修

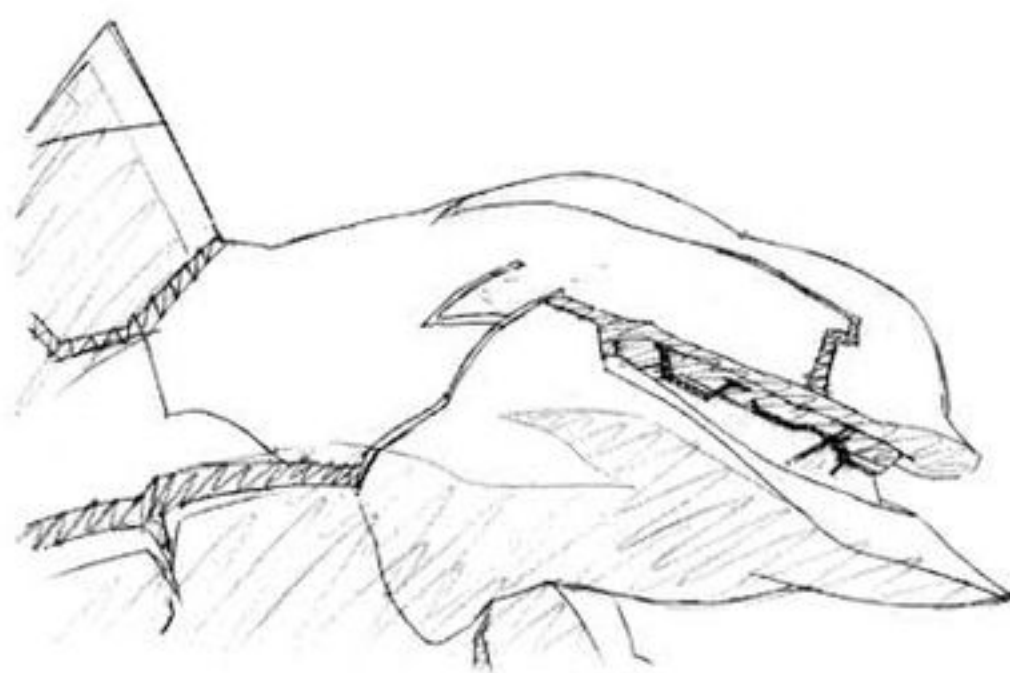

A(2) 修



A(10) 修

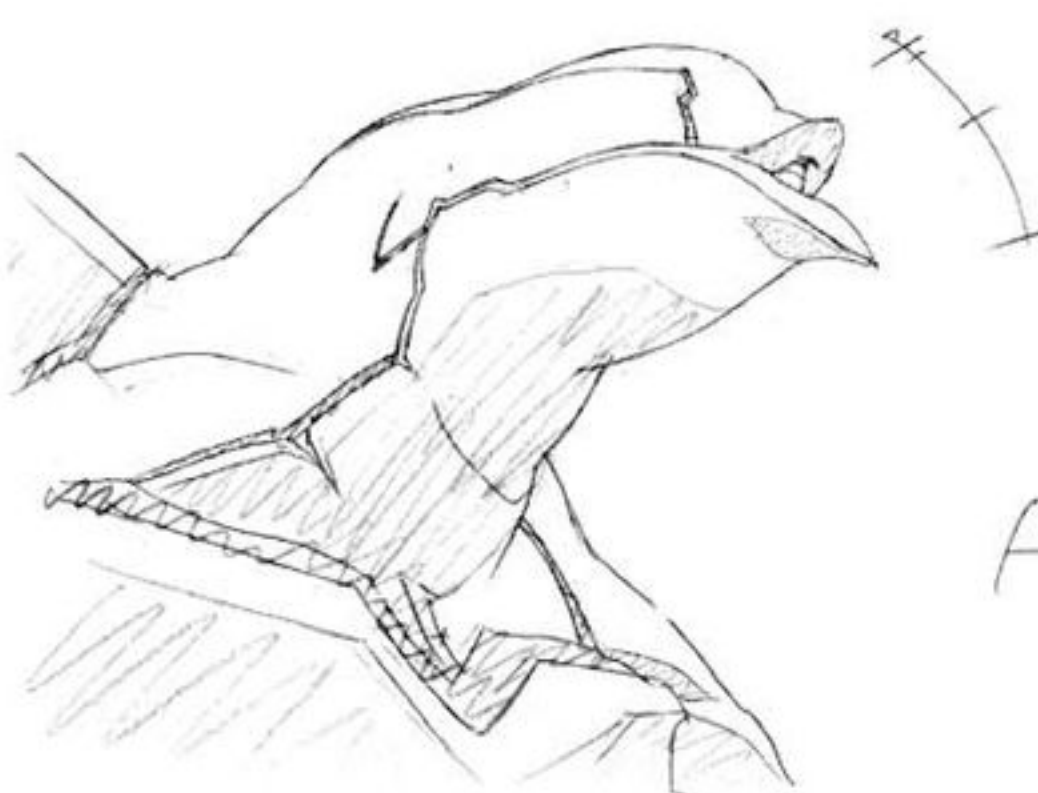

A(4) 修

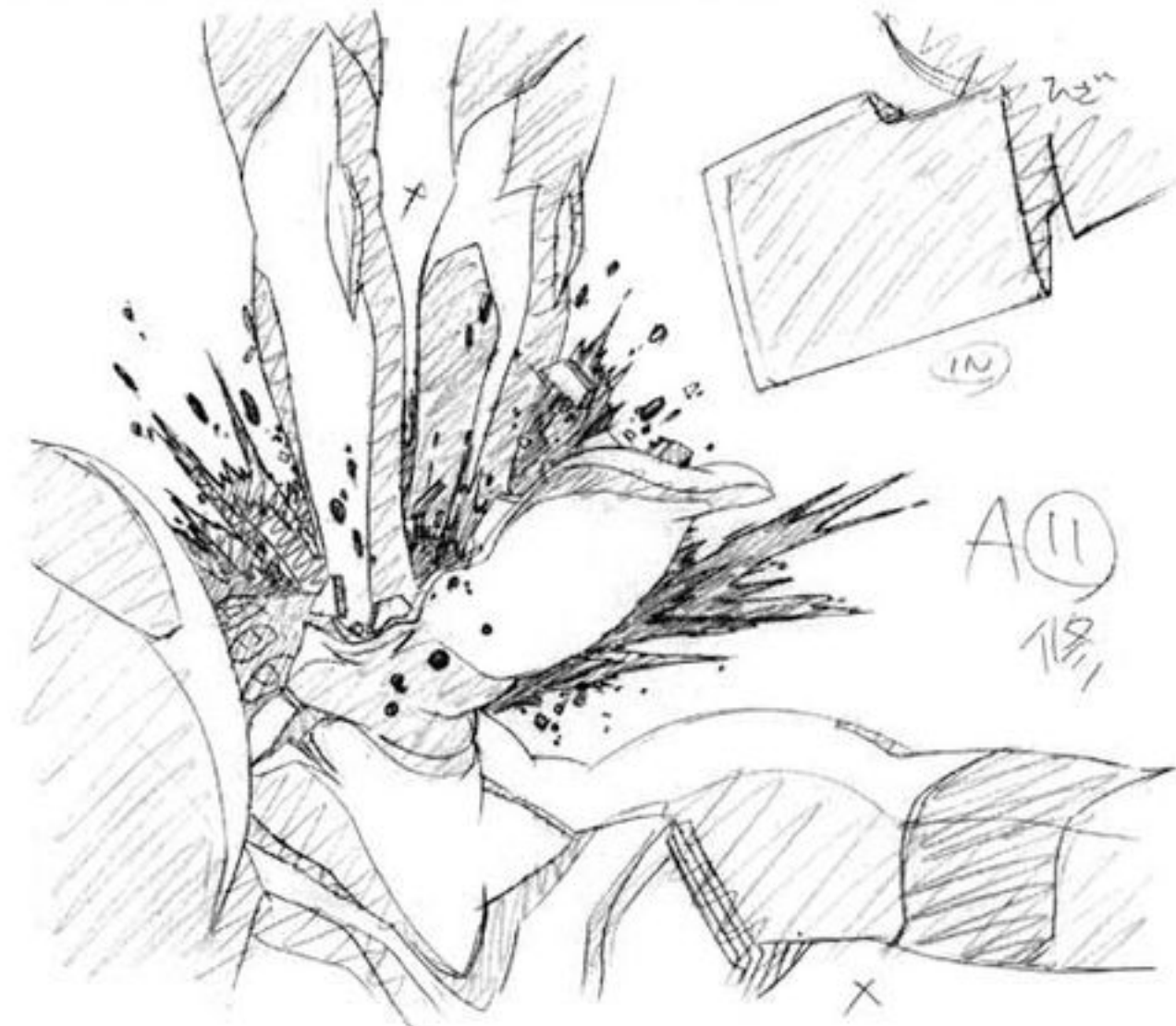

A(11) 修

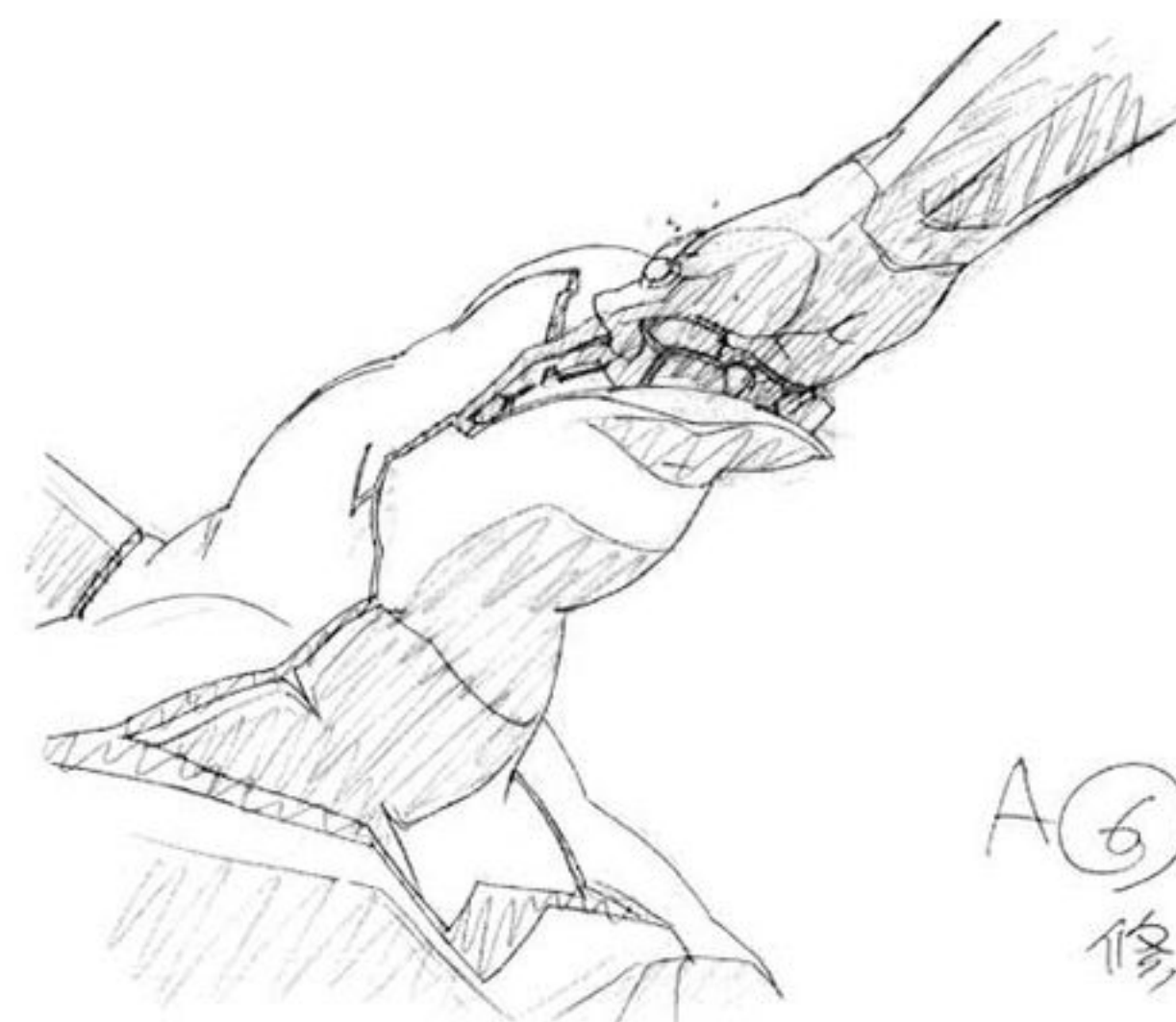

A(6) 修

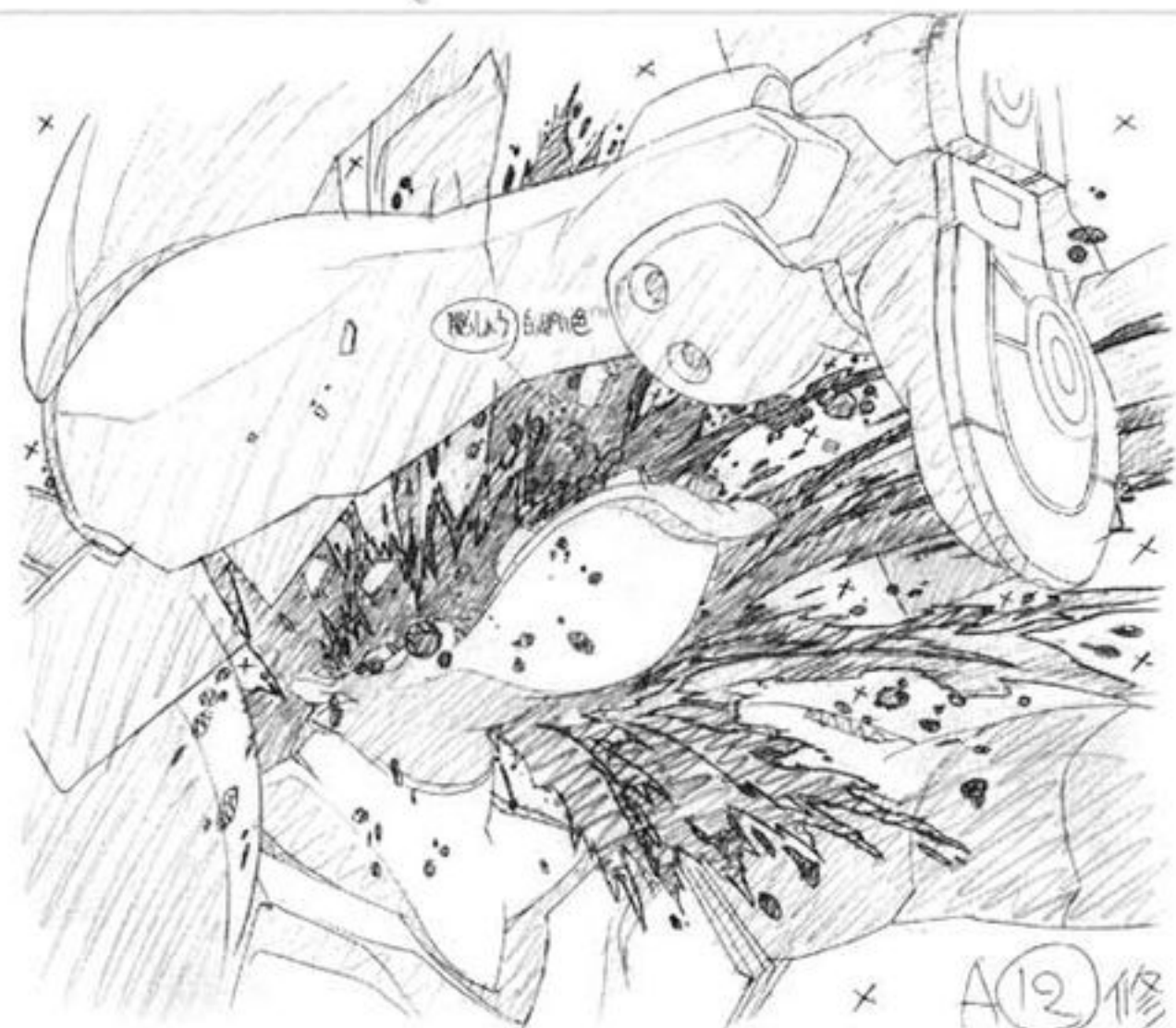

A(12) 修

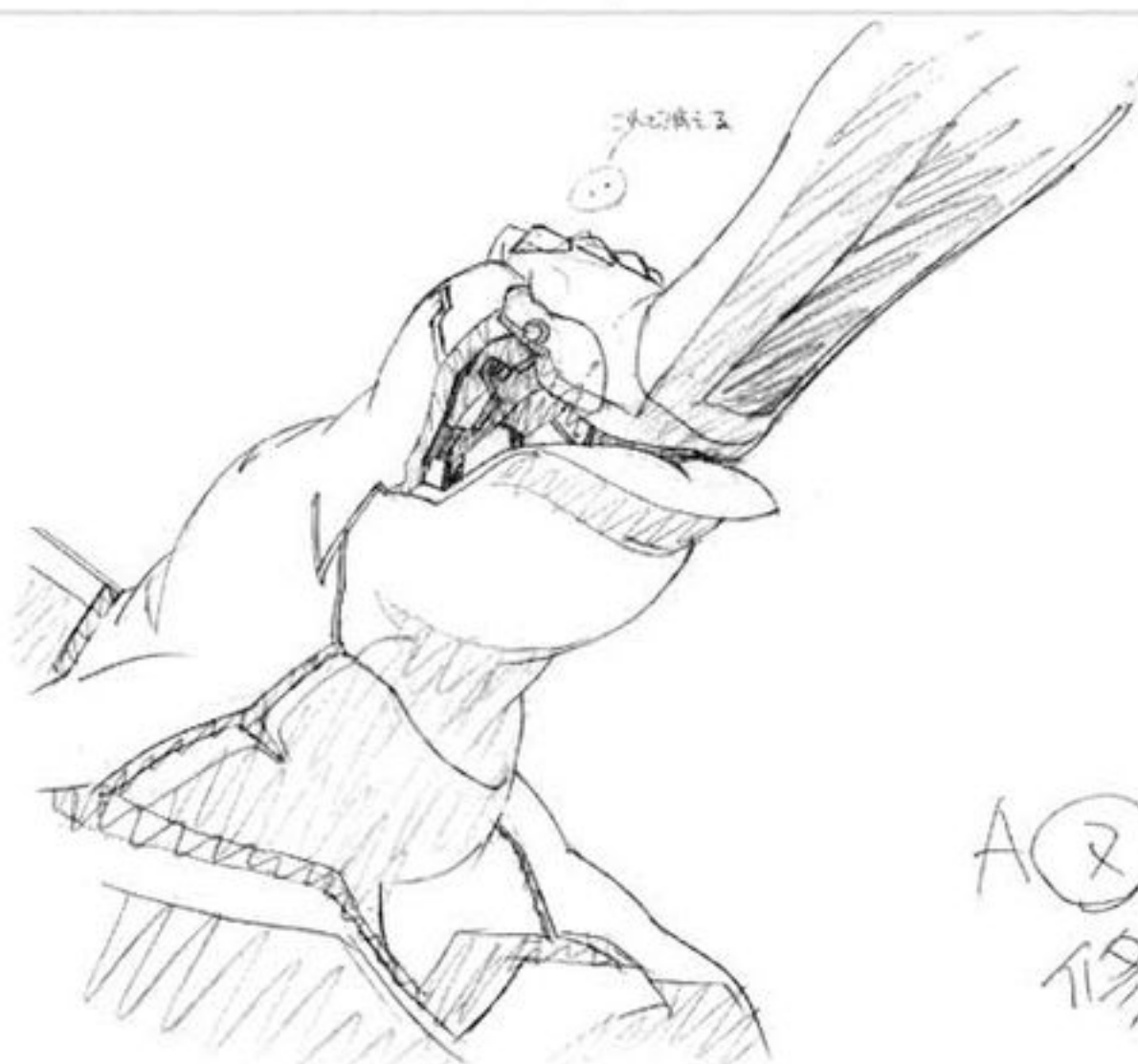

A(7) 修



2	X	2
	/	4
	/	6
4	①	8
6	X	10
7		12
	/	14
8		16
	/	18
	/	20
	/	22
	/	24
10		26
11		28
	/	30
12		32
	/	34
13		36
	/	38
	/	40
	/	42
18		44
		46
		48
		50

タイムシート

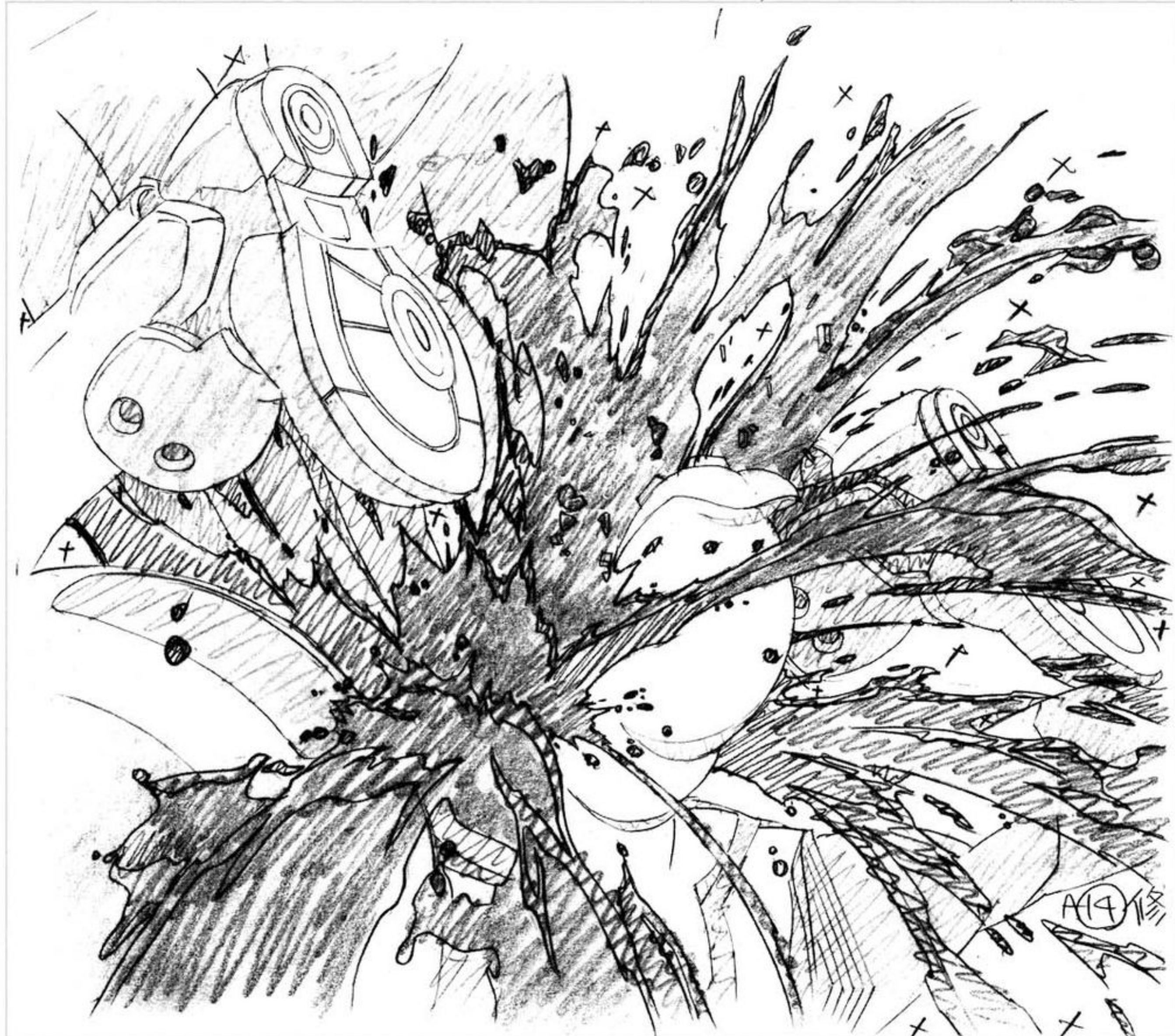
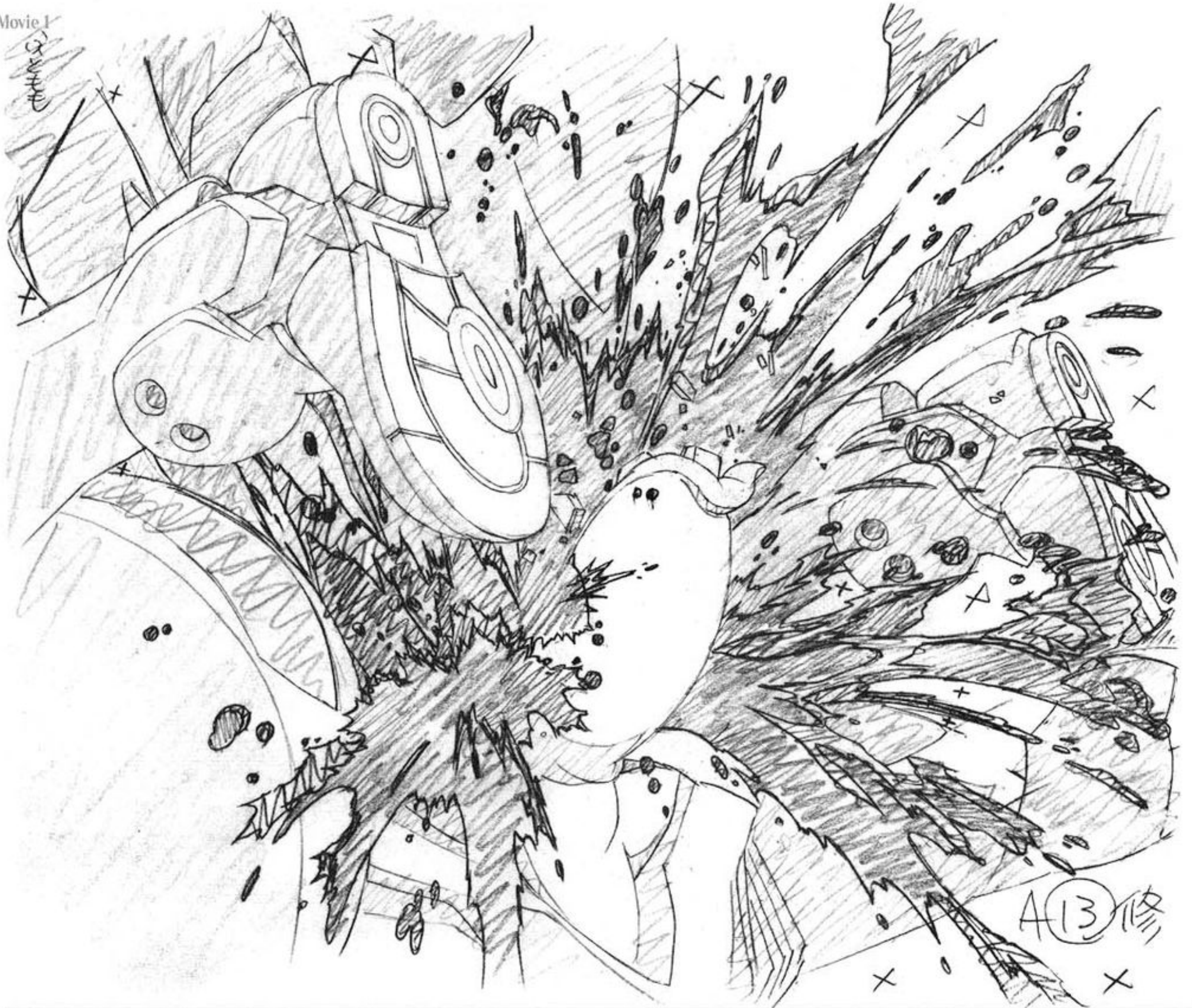



C3<sup>1</sup>



修正原画

#25-C603



(2)



(4)

C2  
M



修正原画

C4<sup>M</sup>



修正原画



(3)



修正原画



(5)



(5) W



修正原画

修正原画



(7) W



(6)



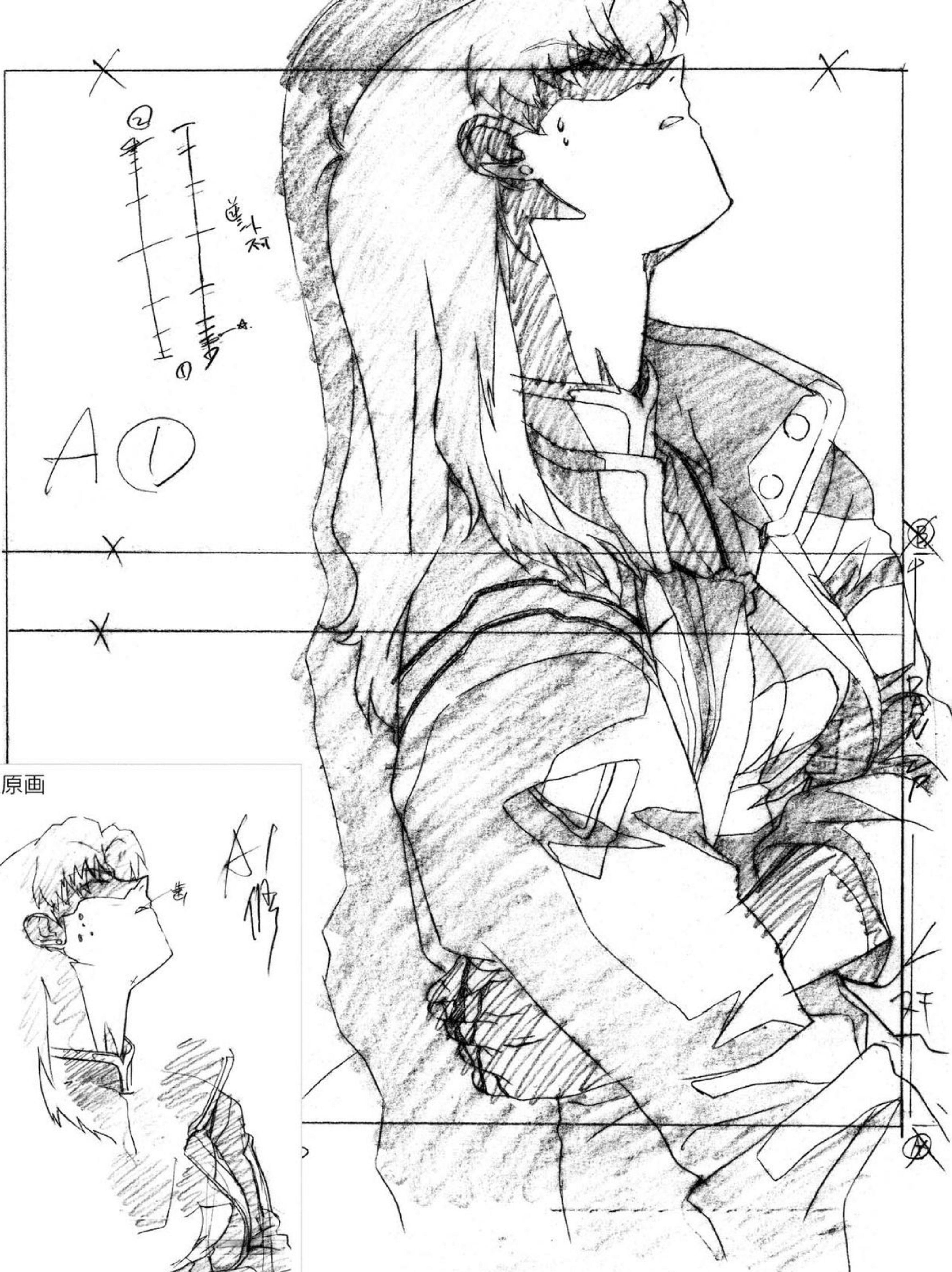

修正原画



#25-C608





修正原画



(3) (3) 1/2



ART

AO 1/2



修正原画





A(4)  
END



A(4)  
END

修正原画



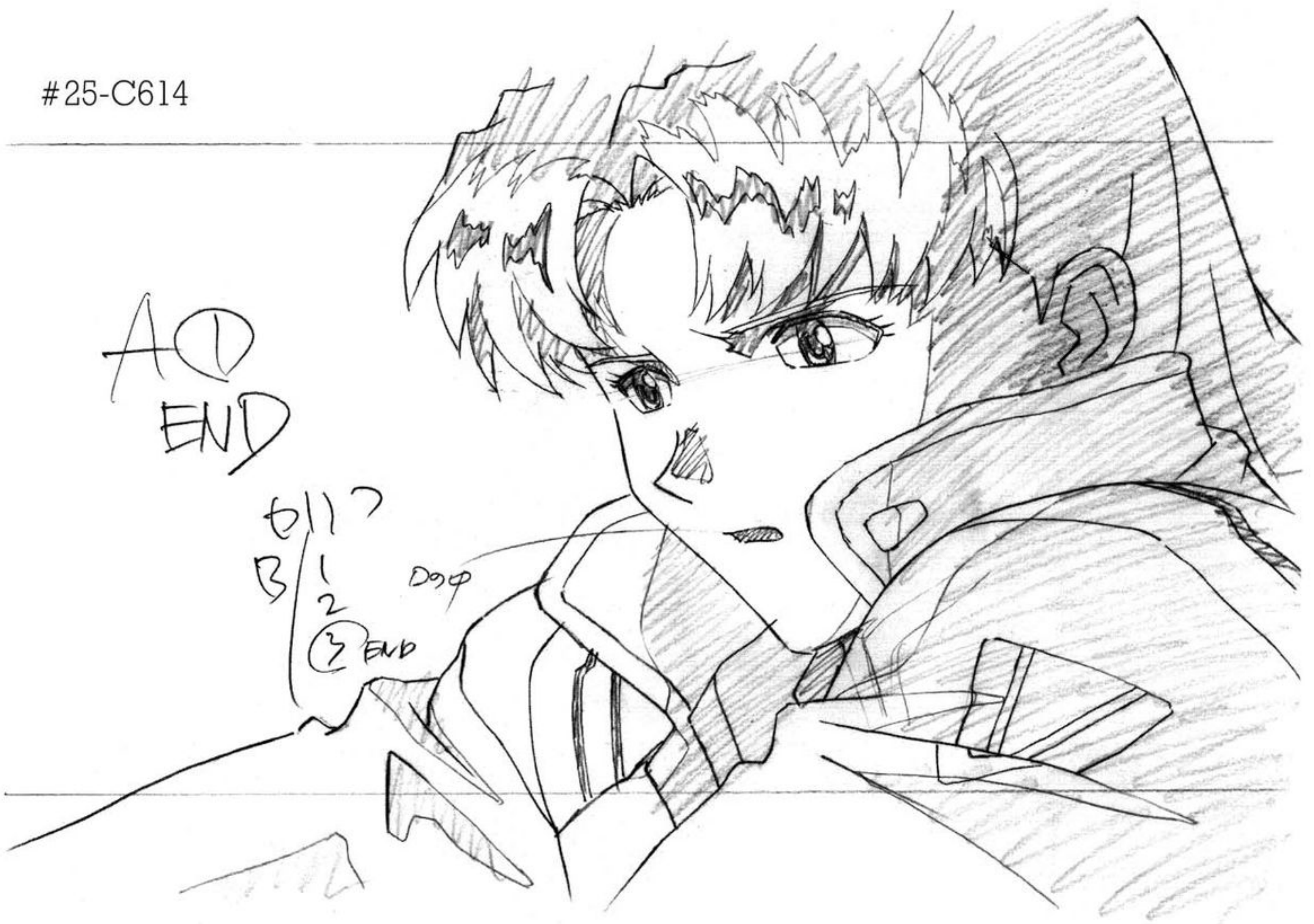

修正原画





#25-C618,620,622

A(1)

2117  
B / 1  
2  
3



修正原画

A / 1  
2  
3  
B-4  
2  
3

馬





修正原画



#25-C618,620,622







修正原画



修正原画





修正原画

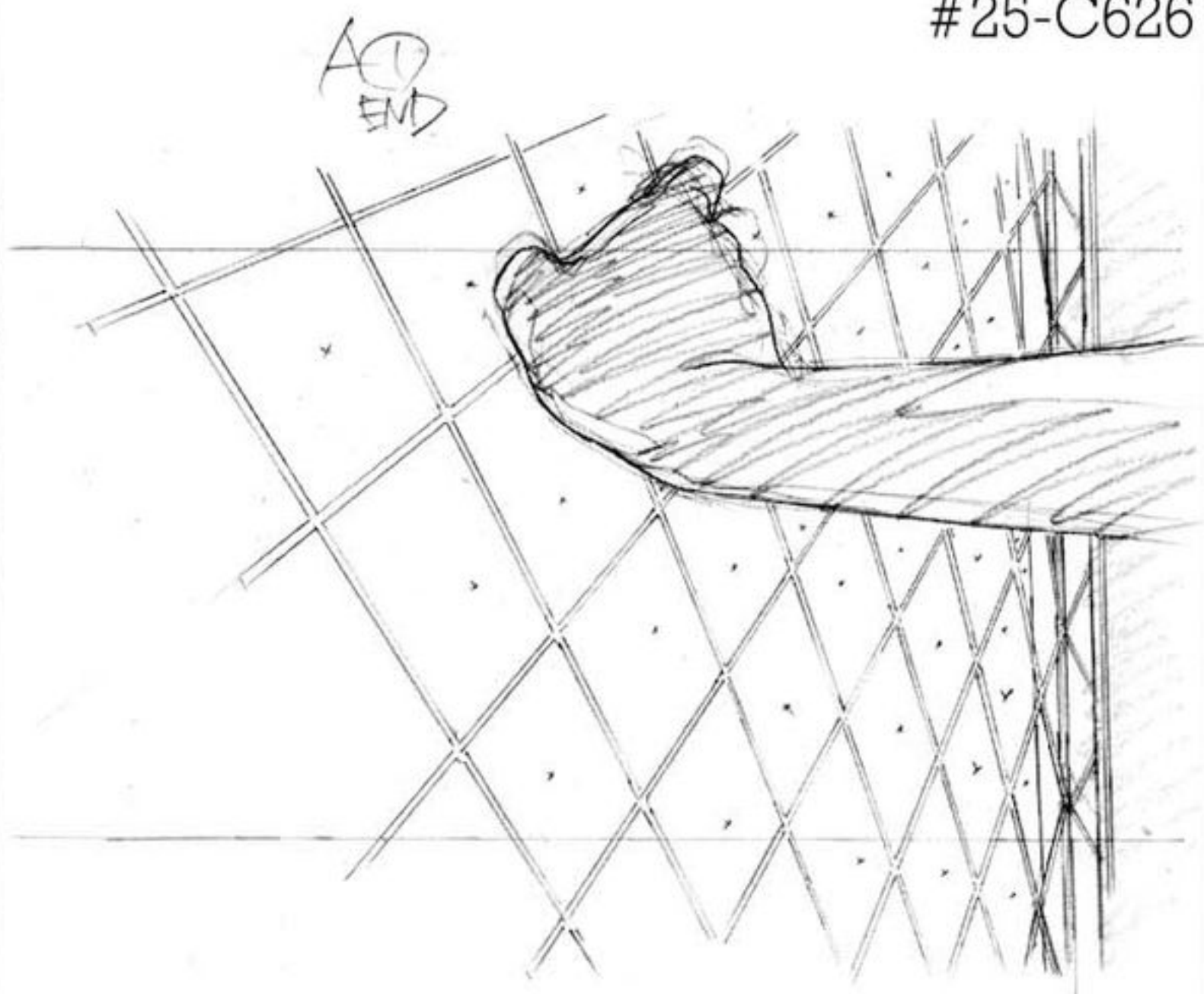

修正原画

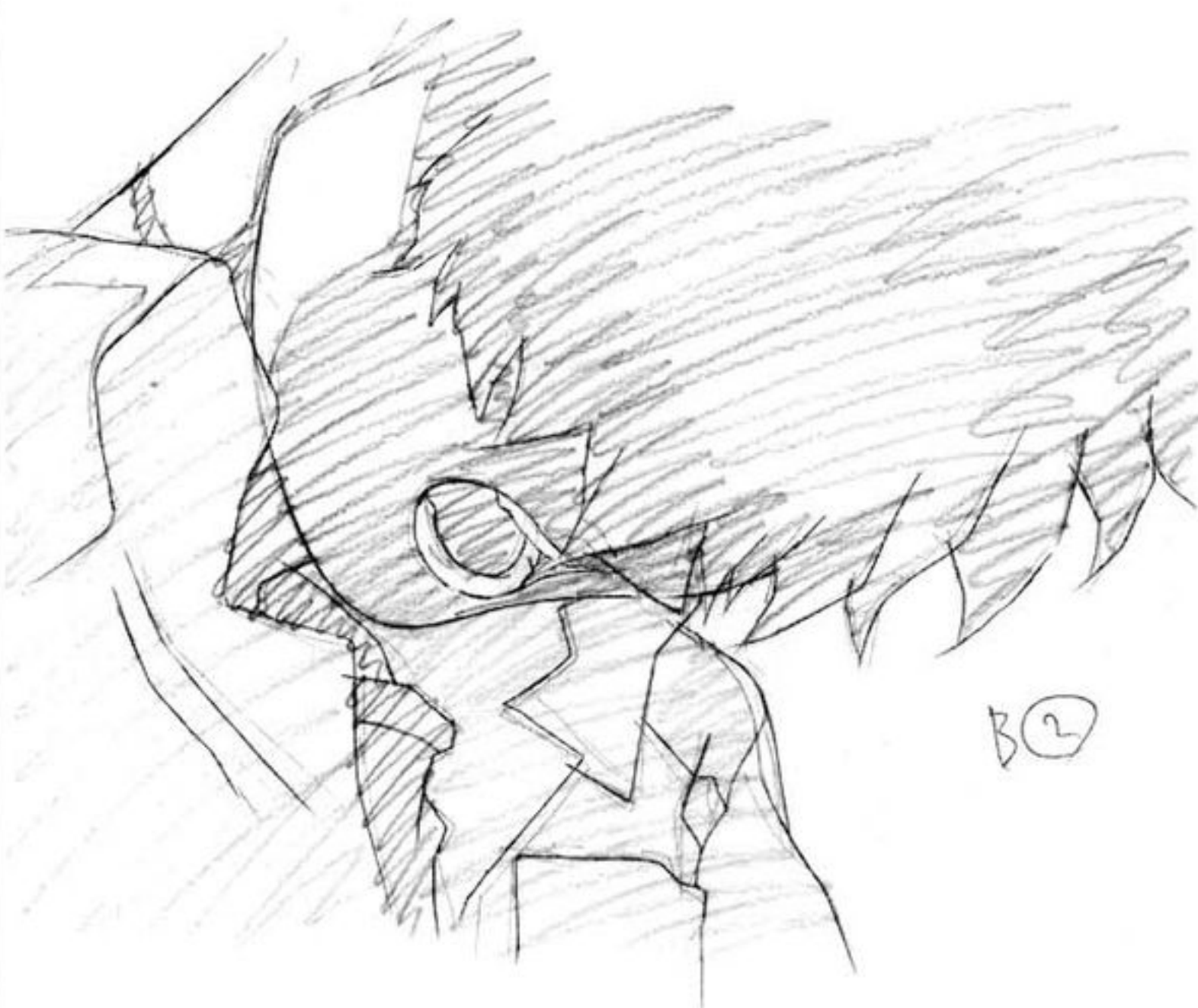

B②

AB	
(1)	2
(2)	4
、	6
(3)	8
、	10
(4)	12
、	14
、	16
(5)	18

タイムシート



A-1 修



修正原画

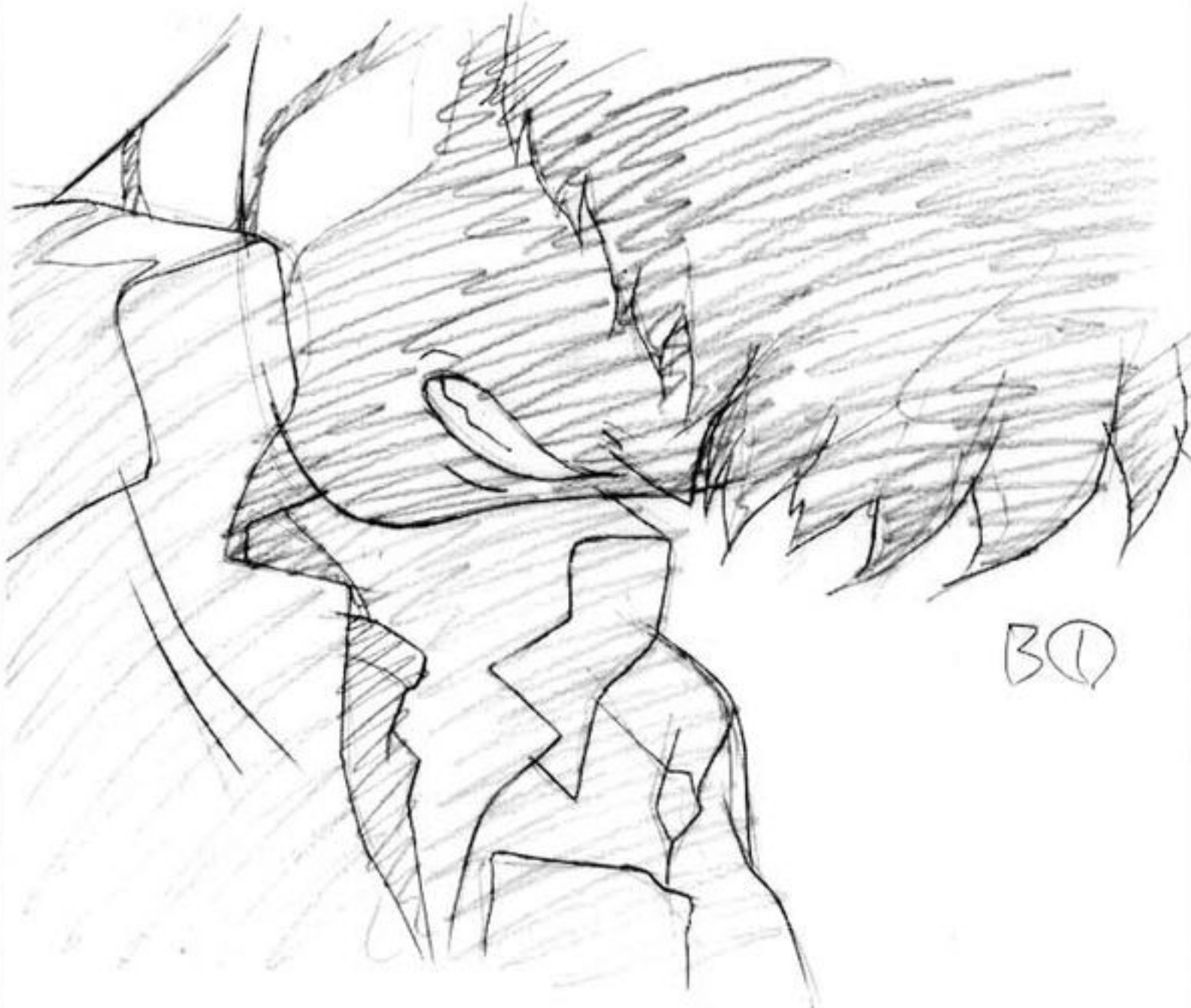

B①



修正原画



B-4  
SM



①  
②  
③  
④  
⑤  
⑥  
⑦  
⑧  
⑨  
⑩  
⑪  
⑫  
⑬  
⑭  
⑮  
⑯  
⑰  
⑱  
⑲  
⑳  
㉑  
㉒  
㉓  
㉔  
㉕  
㉖  
㉗  
㉘  
㉙  
㉚  
㉛  
㉜  
㉝  
㉞  
㉟  
㊱  
㊲  
㊳  
㊴  
㊵  
㊶  
㊷  
㊸  
㊹  
㊺  
㊻  
㊼  
㊽  
㊾  
㊿  
B(3)  
涙、汗の出る

修正原画

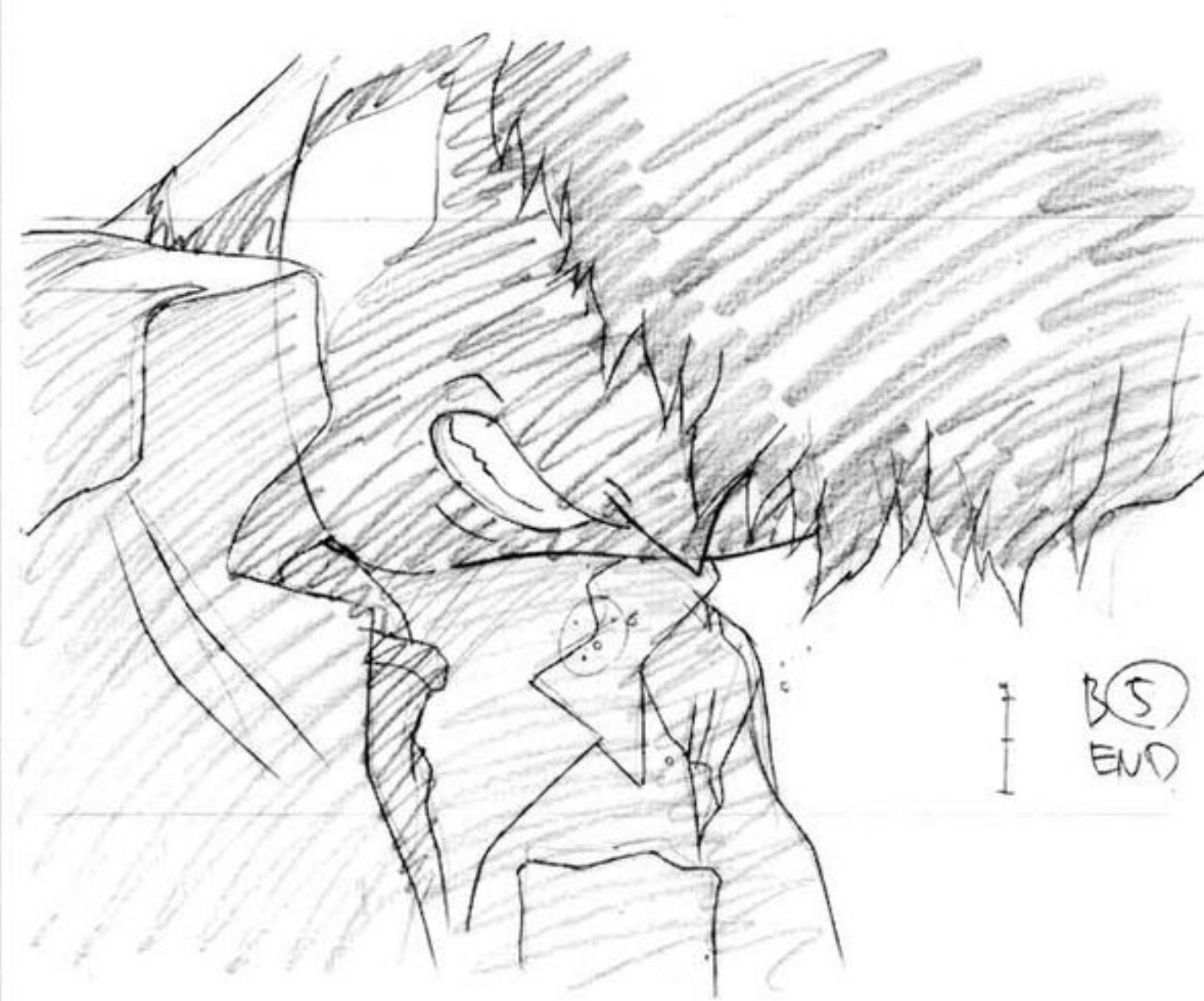

B(5)  
END



B-3  
SM  
涙は  
原画の  
整の下に描  
F-11



修正原画

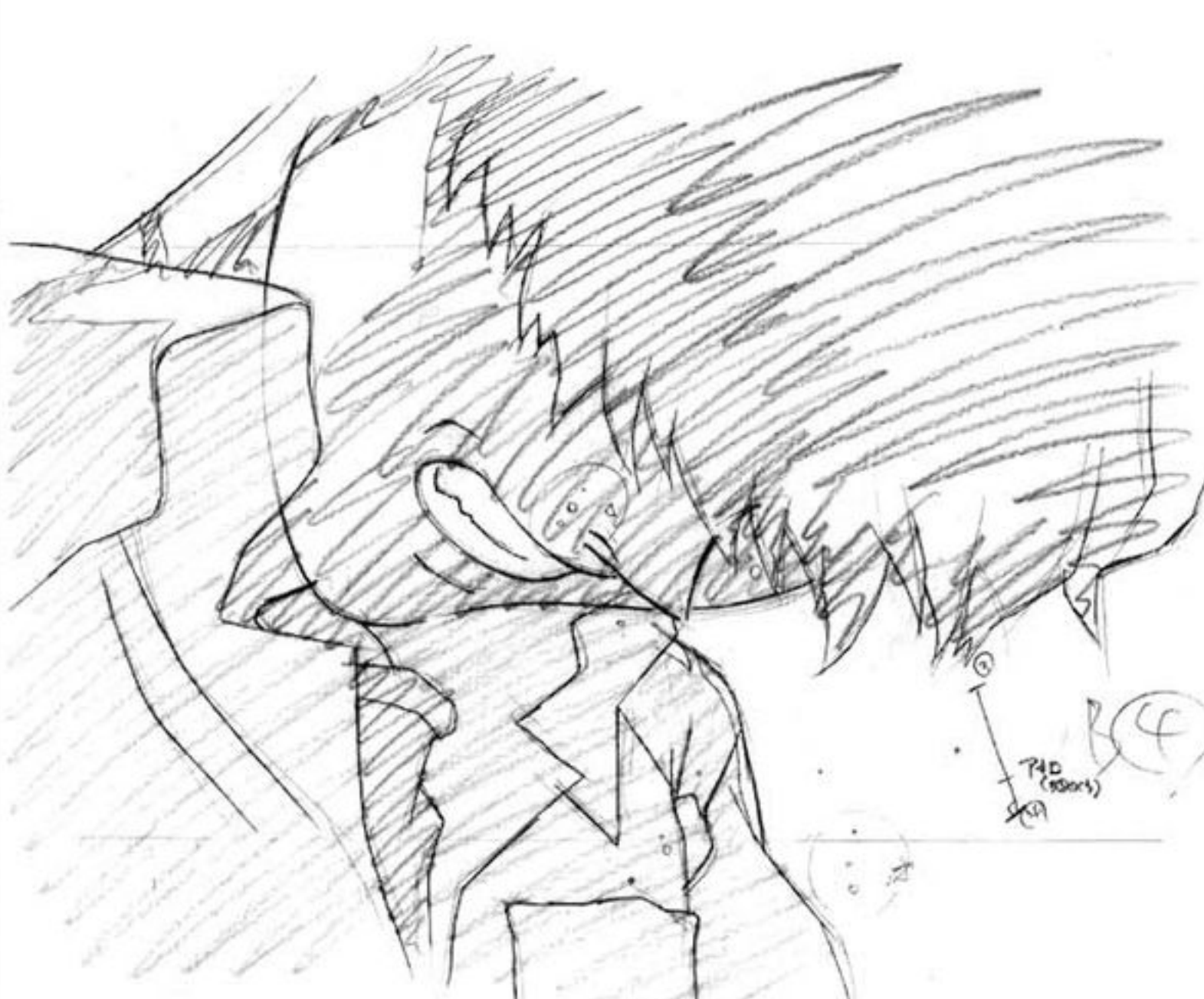

B(4)  
TAD  
(2000)  
SM



A(1)



修正原画

A(2)



修正原画





修正原画

A(3)



修正原画

A(4)







A④



腫の1.5倍  
BとLの  
+1.5

A④



他同様に  
FL

②+1.5  
A③



手  
↑  
↓  
手

腫の1.5倍 C①

腫の1.5倍(実線)

D①

A⑤



A①  
B①



#25-C636,638

A⑤





BO

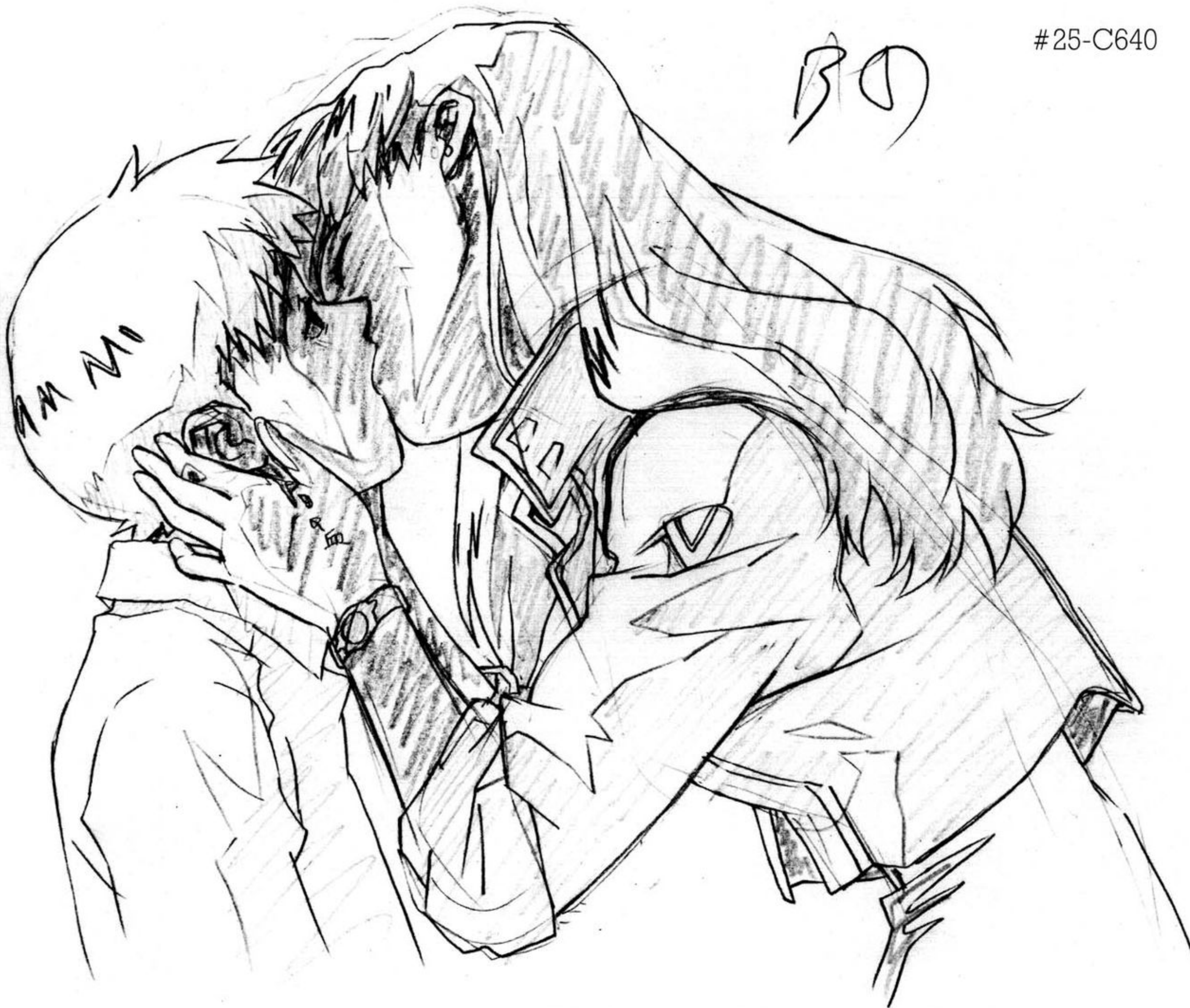

↑ ↓

ラッパ  
中野と石野の

BA



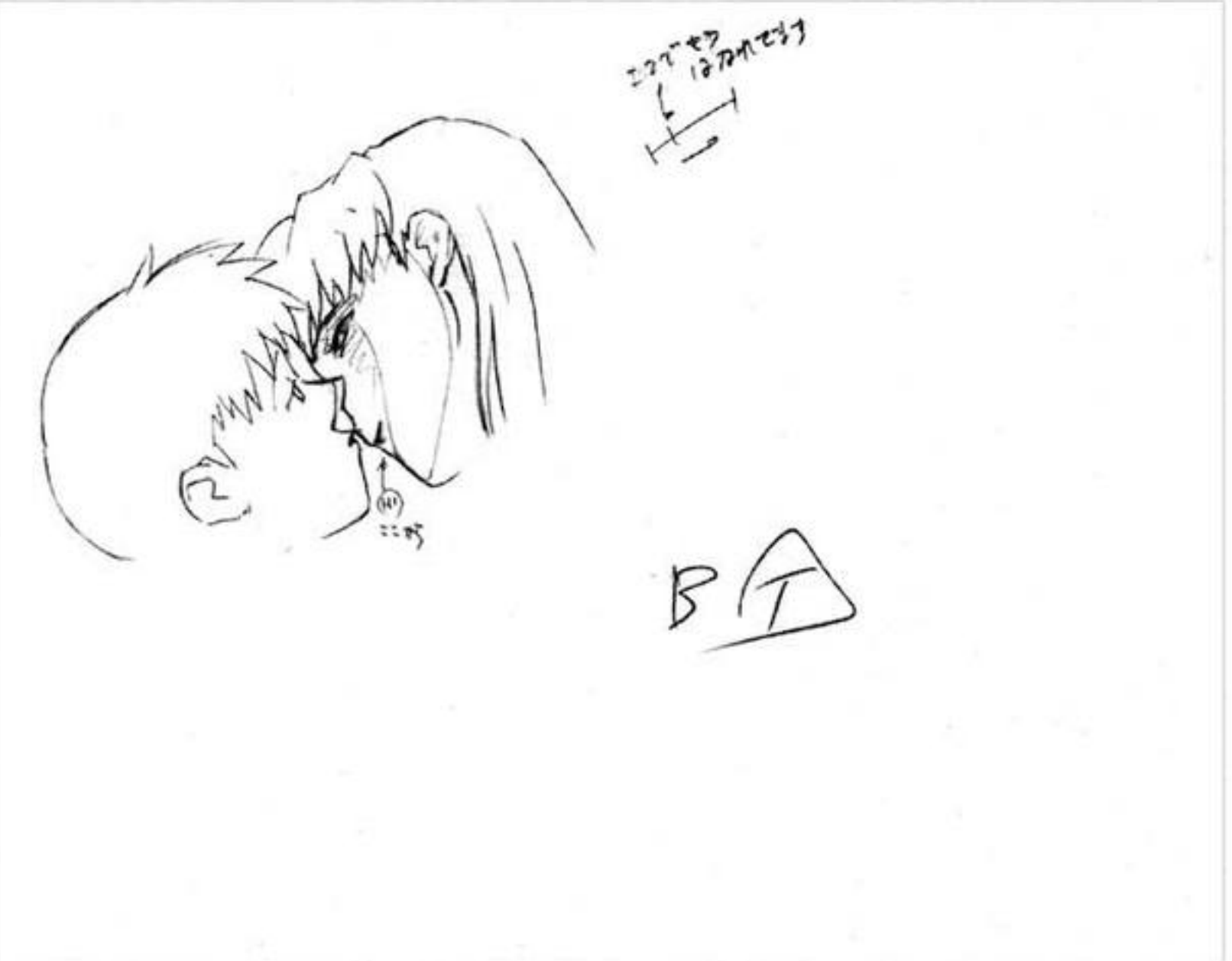
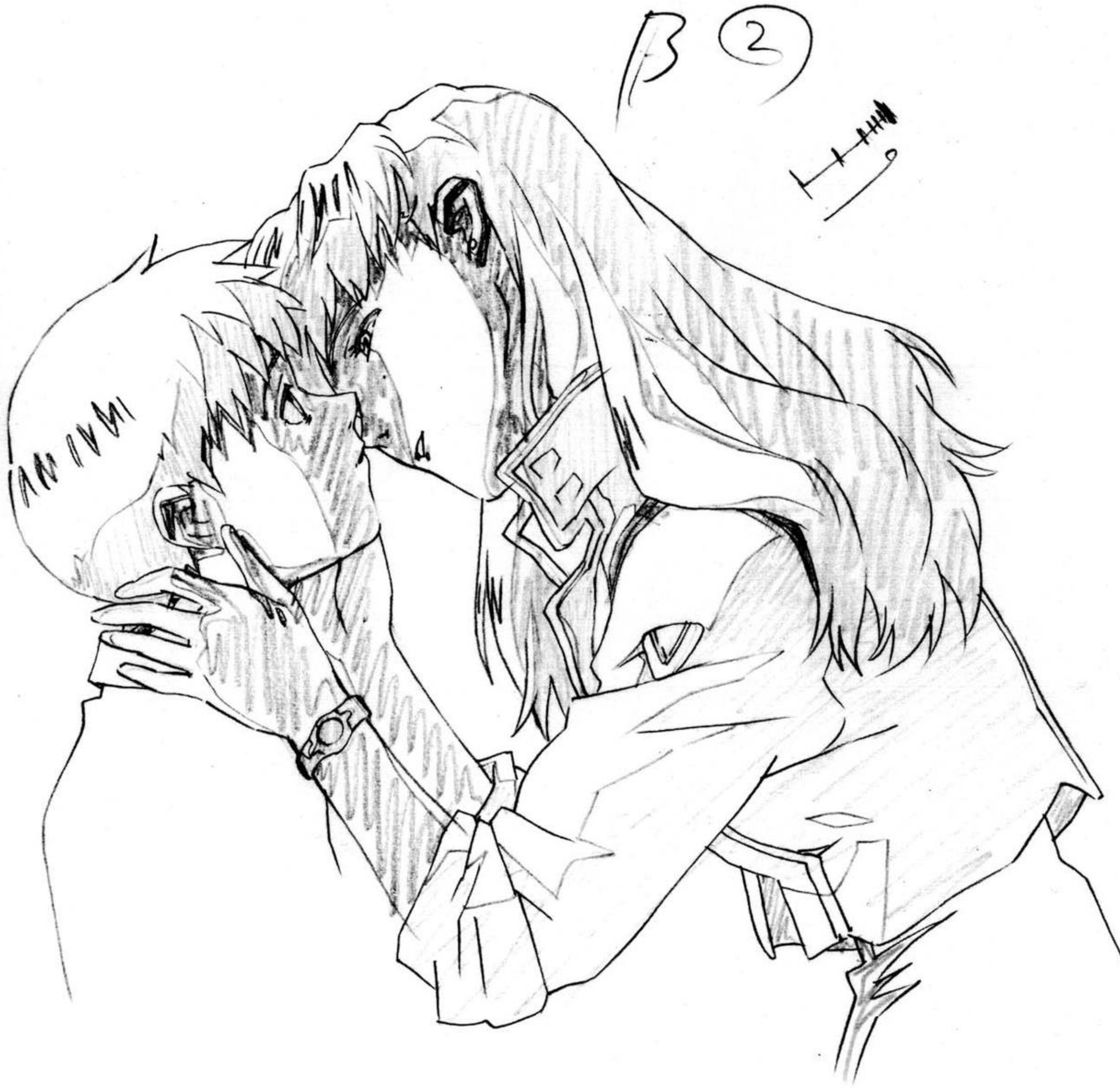





#25-C643

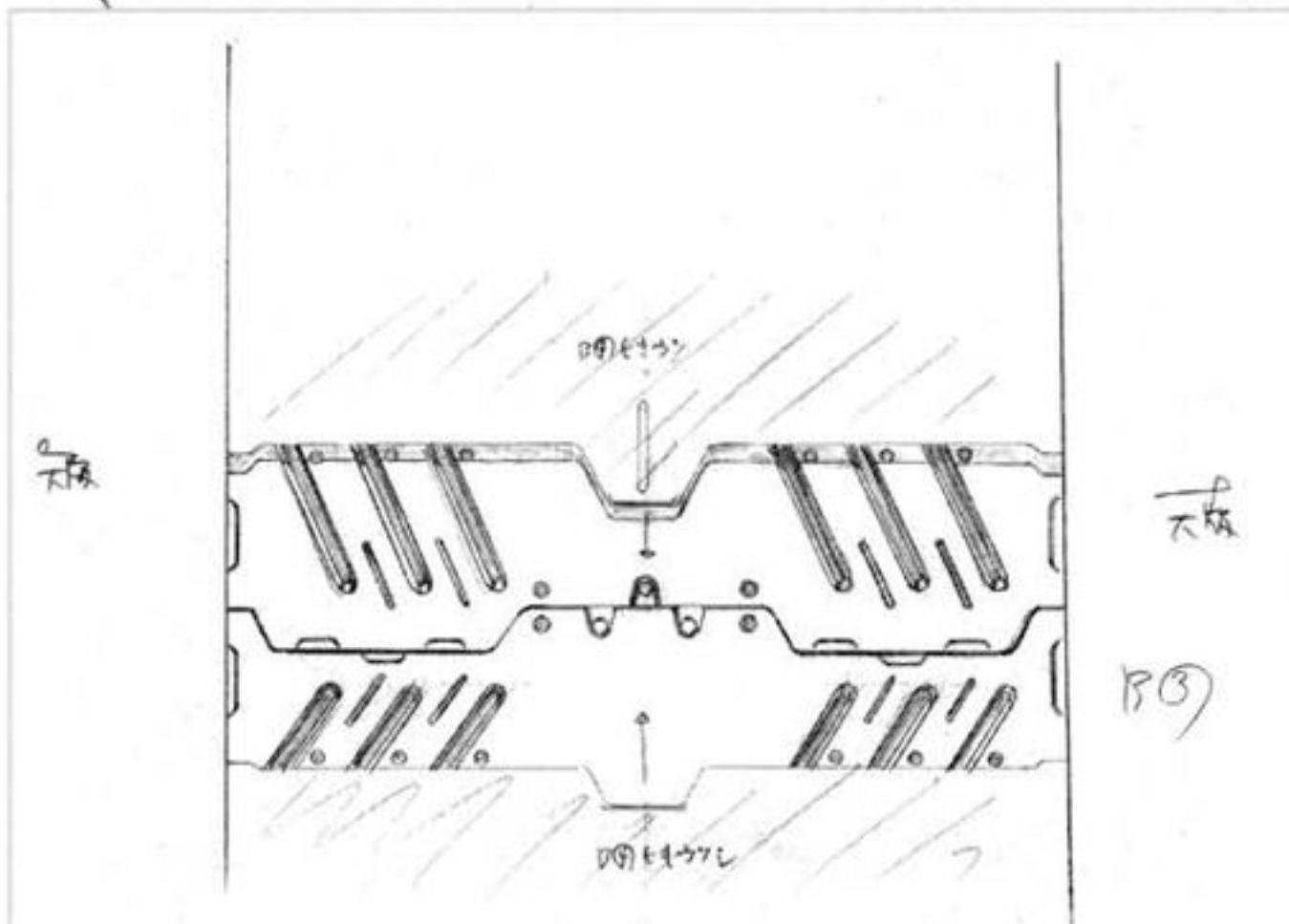

A(1)

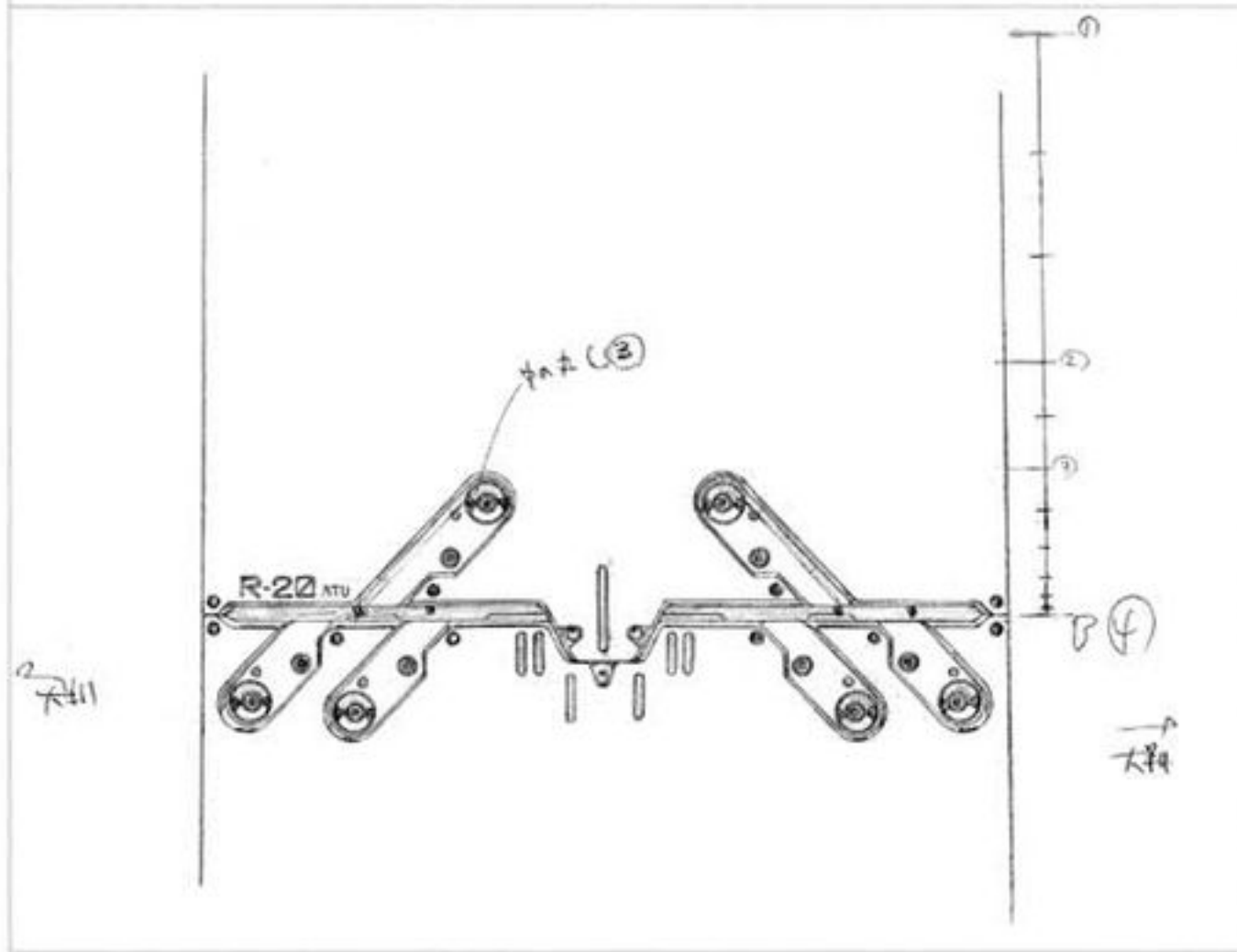



ABC	
①	
②	
③	
④	
⑤	
⑥	
⑦	
⑧	
⑨	
⑩	
⑪	
⑫	
⑬	
⑭	
⑮	
⑯	
⑰	
⑱	
⑲	
⑳	
㉑	
㉒	
㉓	
㉔	
㉕	
㉖	
㉗	
㉘	
㉙	
㉚	
㉛	
㉜	
㉝	
㉞	
㉟	
㊱	
㊲	
㊳	
㊴	
㊵	
㊶	
㊷	
㊸	
㊹	
㊺	
㊻	
㊼	
㊽	
㊾	
㊿	
1	
2	
3	
4	
5	
6	
7	
8	
9	
10	
11	
12	
13	
14	
15	
16	
17	
18	
19	
20	
21	
22	
23	
24	
25	
26	
27	
28	
29	
30	
31	
32	
33	
34	
35	
36	
37	
38	
39	
40	
41	
42	
43	
44	
45	
46	
47	
48	
49	
50	
51	
52	
53	
54	
55	
56	
57	
58	
59	
60	
61	
62	
63	
64	
65	
66	
67	
68	
69	
70	
71	
72	
73	
74	
75	
76	
77	
78	
79	
80	
81	
82	
83	
84	



#25-C642  
タイムシート





A	B	C	
1	2	3	4
5	6	7	8
9	10	11	12
13	14	15	16
17	18	19	20
21	22	23	24
25	26	27	28
29	30	31	32
33	34	35	36
37	38	39	40
41	42	43	44
45	46	47	48
49	50	51	52
53	54	55	56
57	58	59	60
61	62	63	64
65	66	67	68
69	70	71	72

タイムシート

#25-C645



C4  
修正



接地修正  
原画修正



C5  
修正

C1  
修正



接地修正  
原画修正



C6  
修正

C2  
修正



接地修正  
原画修正



C7  
修正

C3  
修正



耳



B0

2220

C2



地の色(2)

#25-C647

修正原画

B1



原画



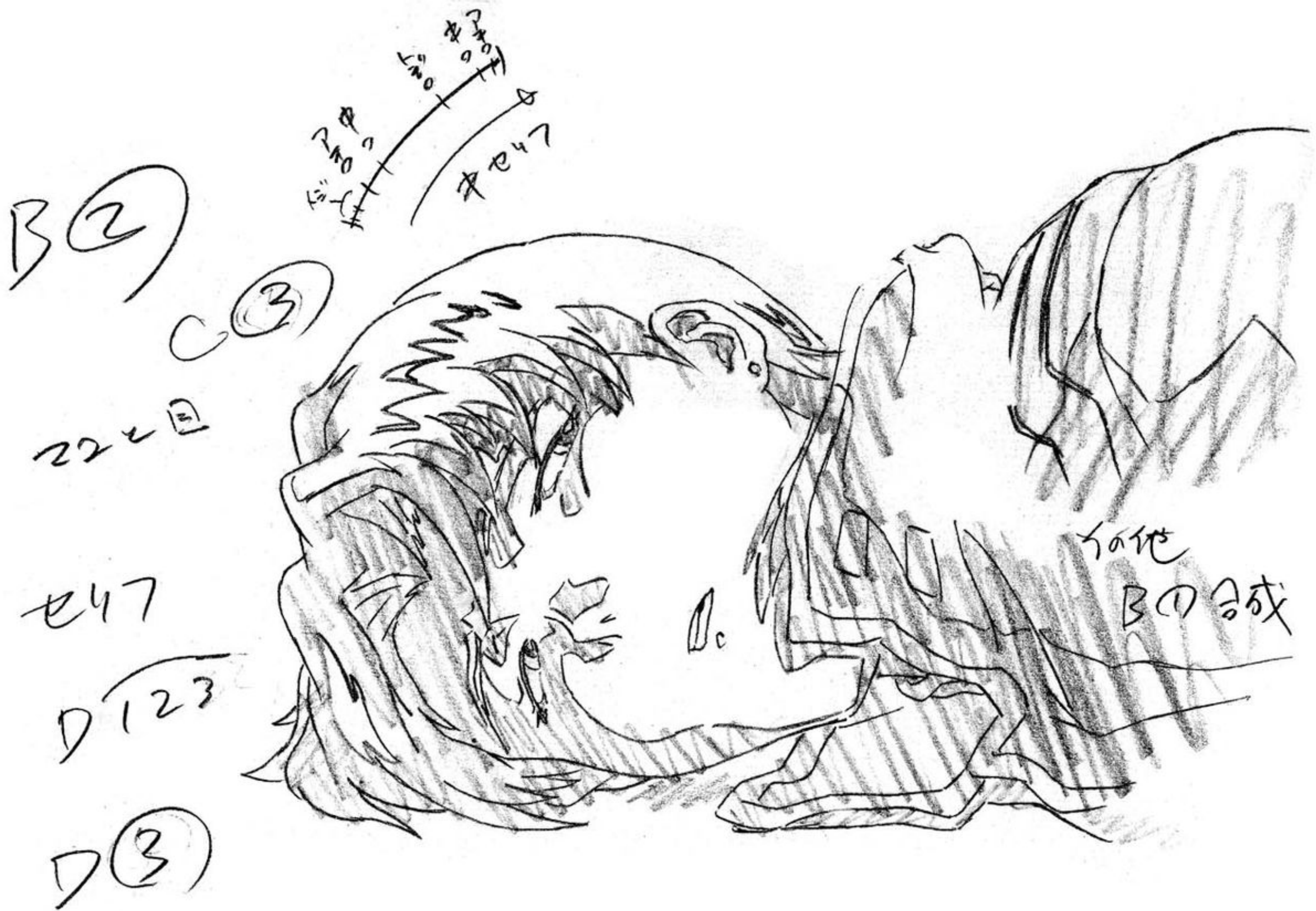

修正原画



A 1 11/3



A 4 11/3



A 3 11/3





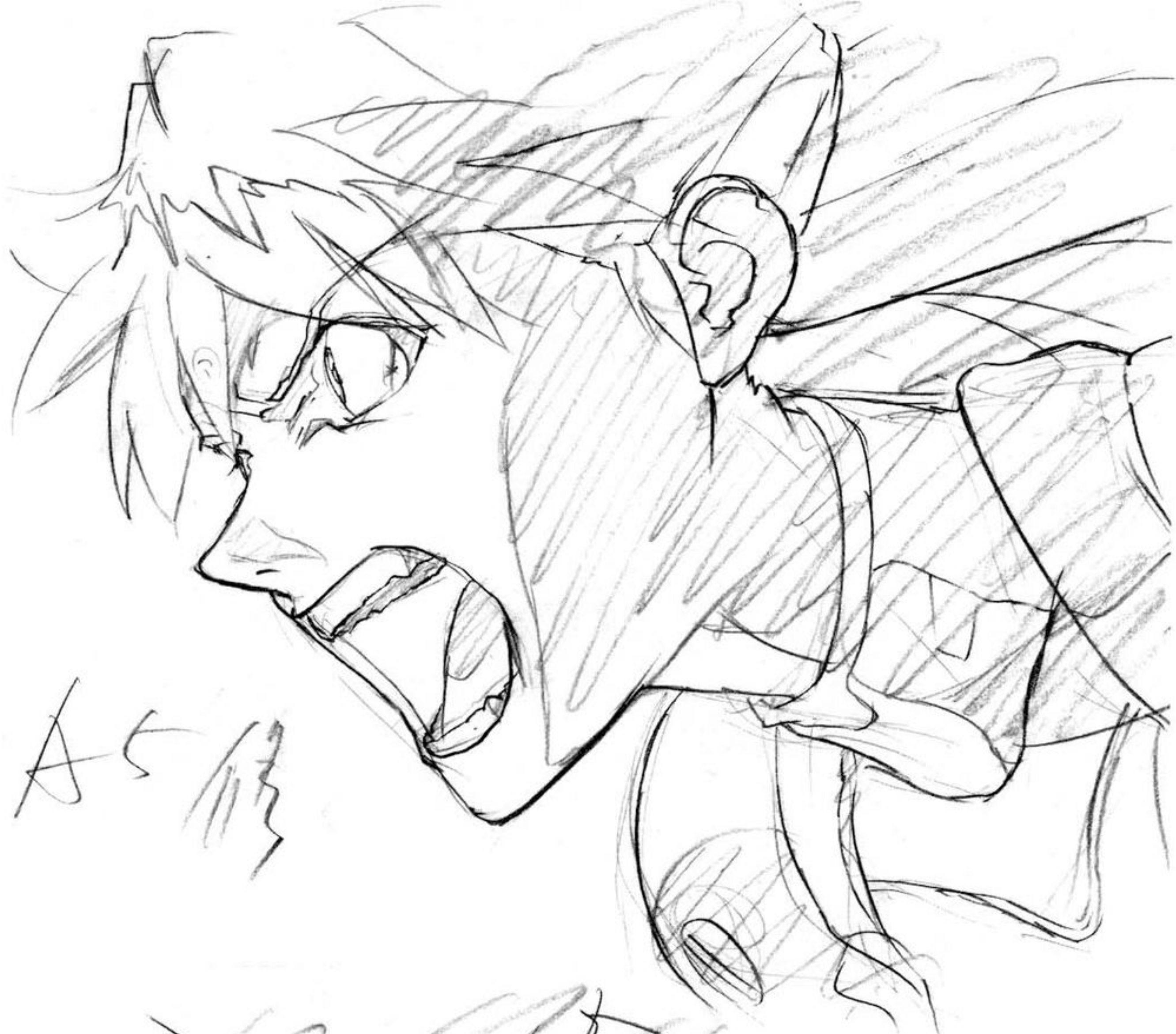

A5



A6M



Alex

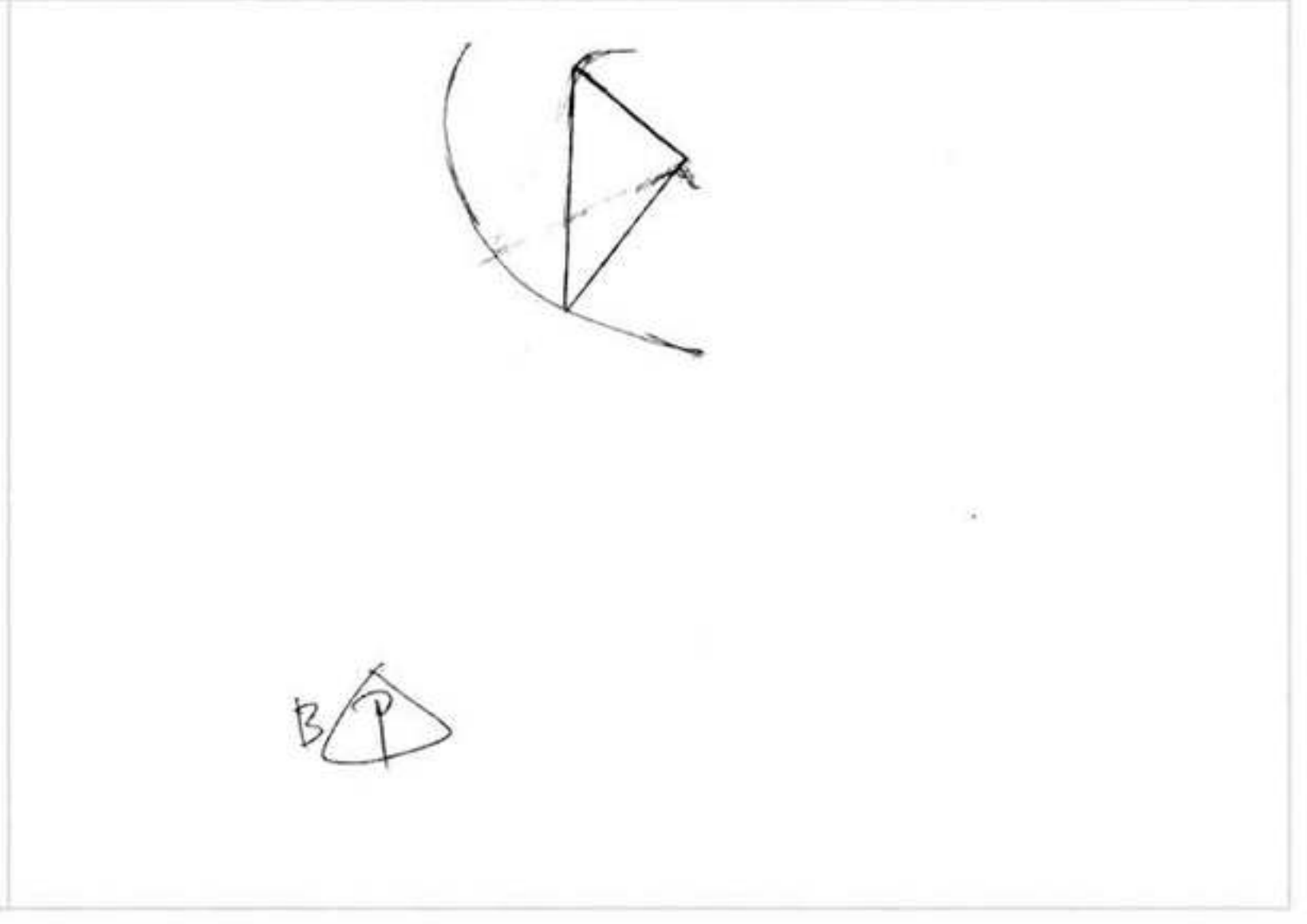
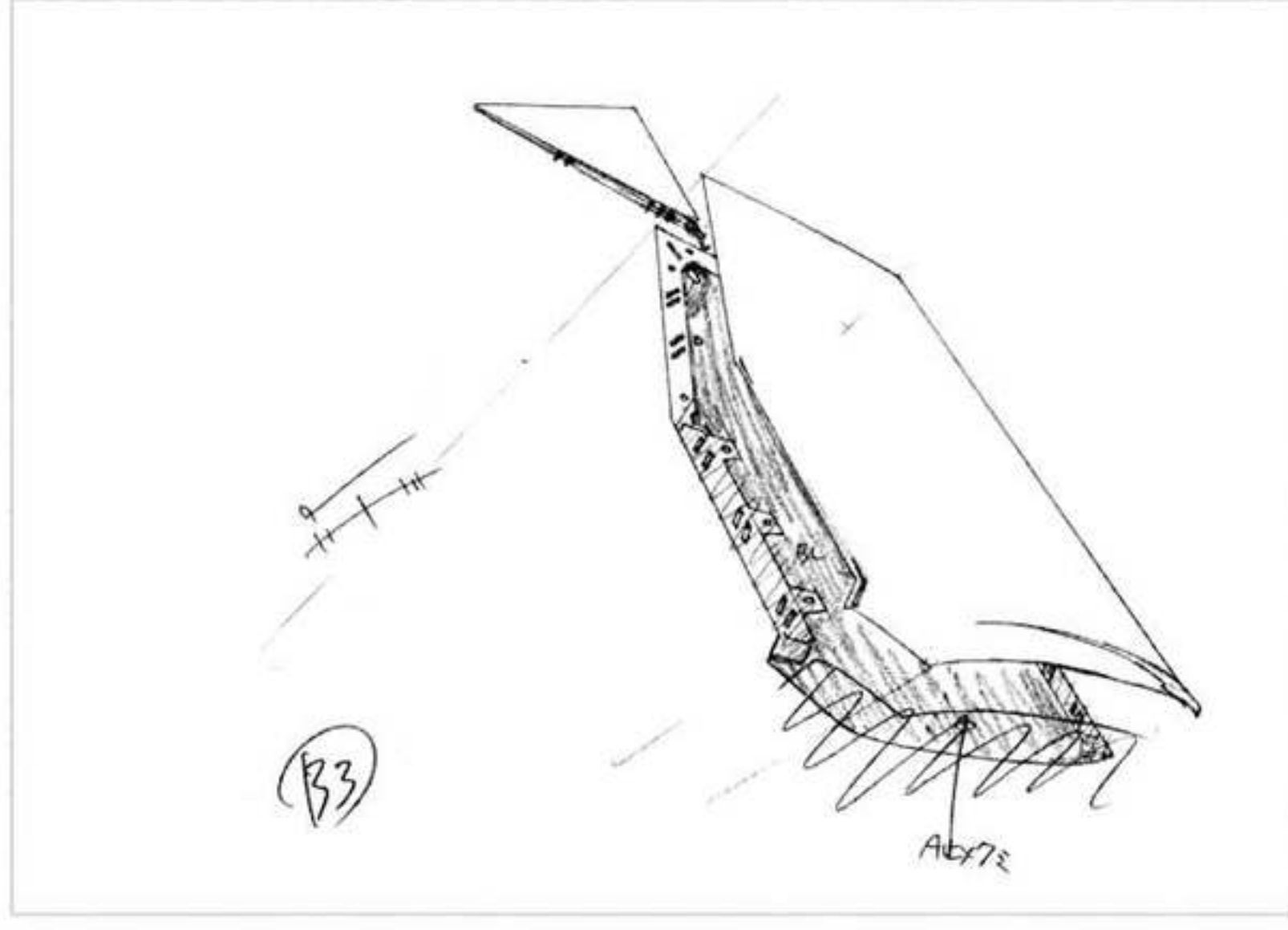
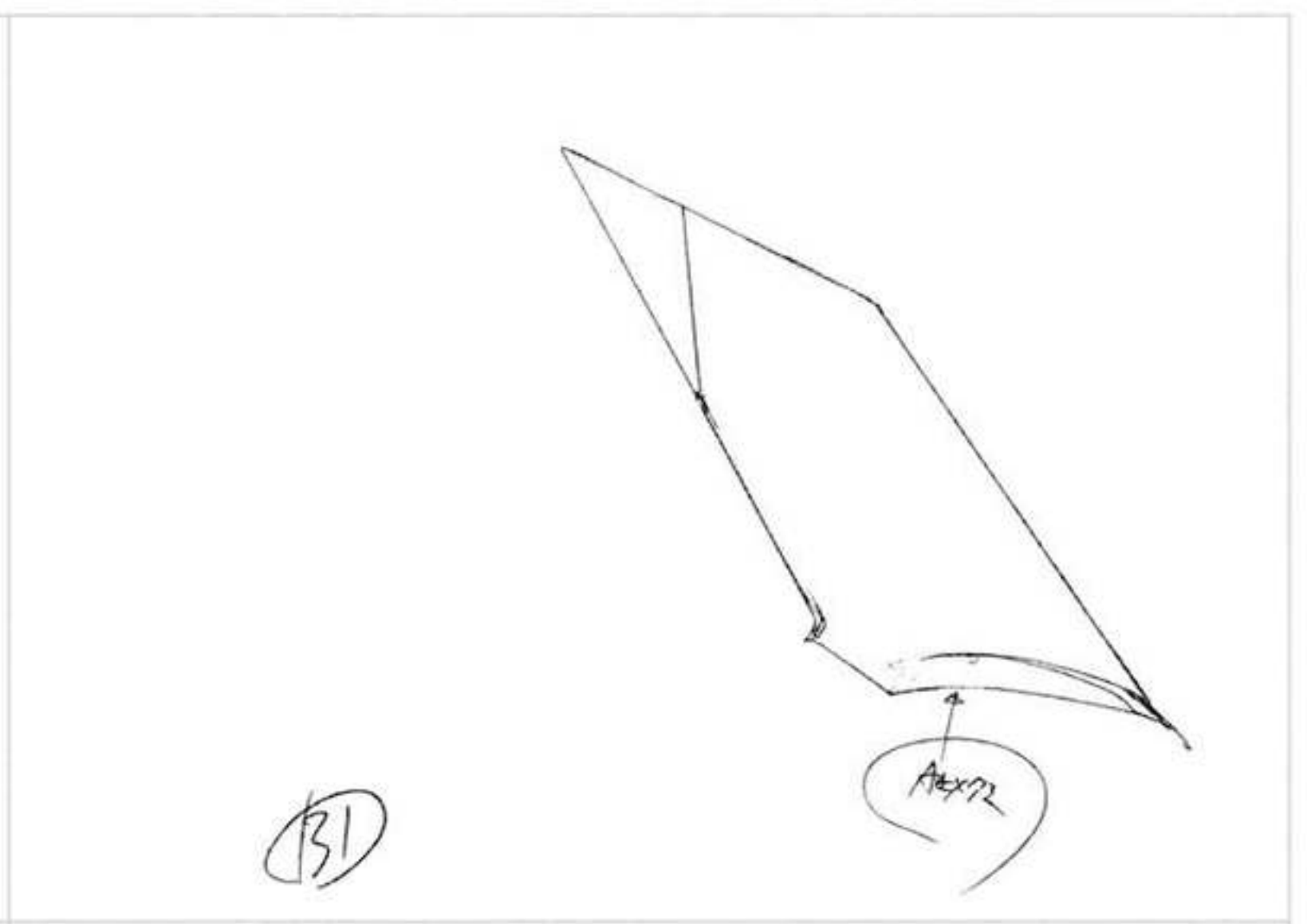
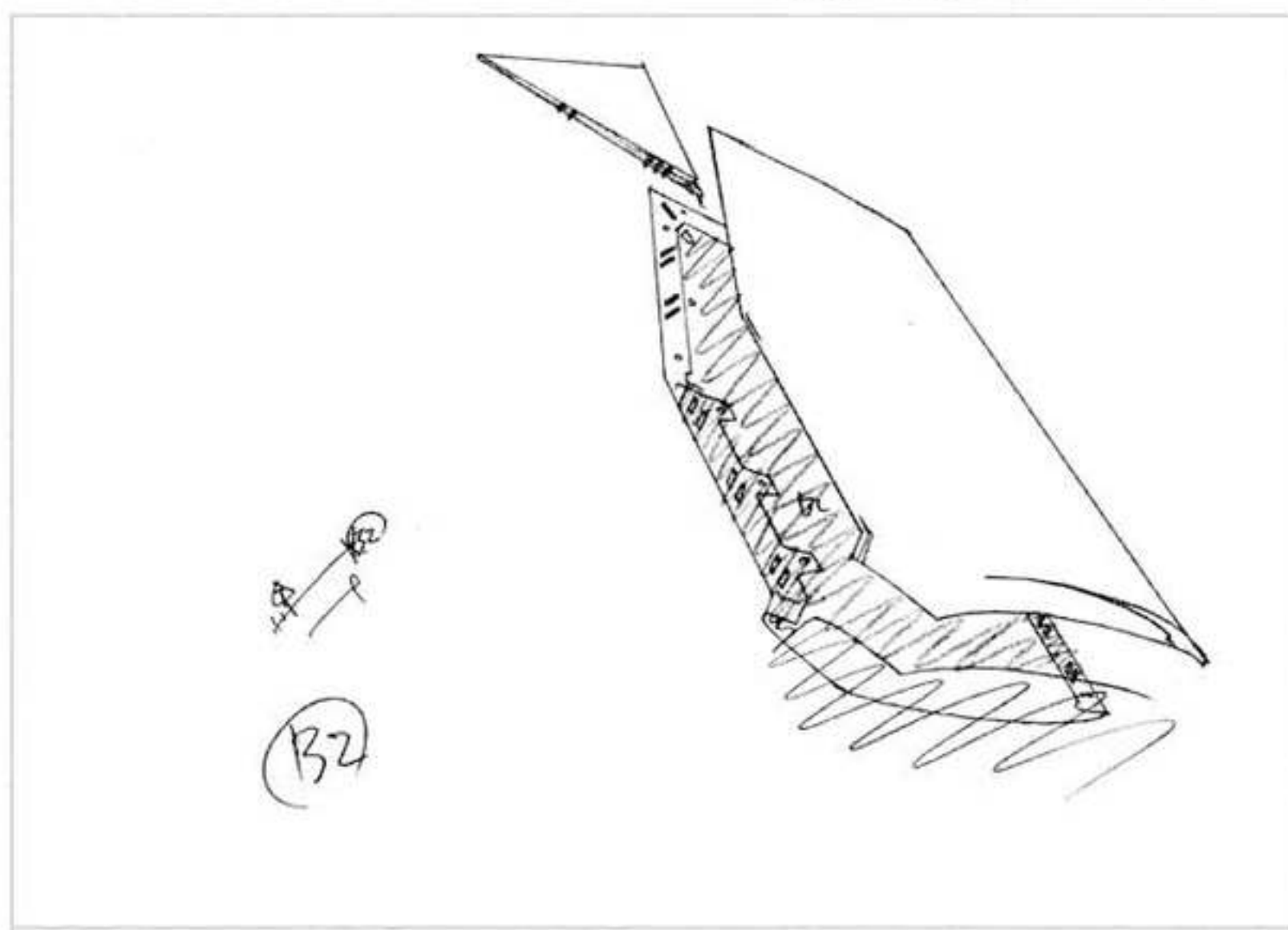
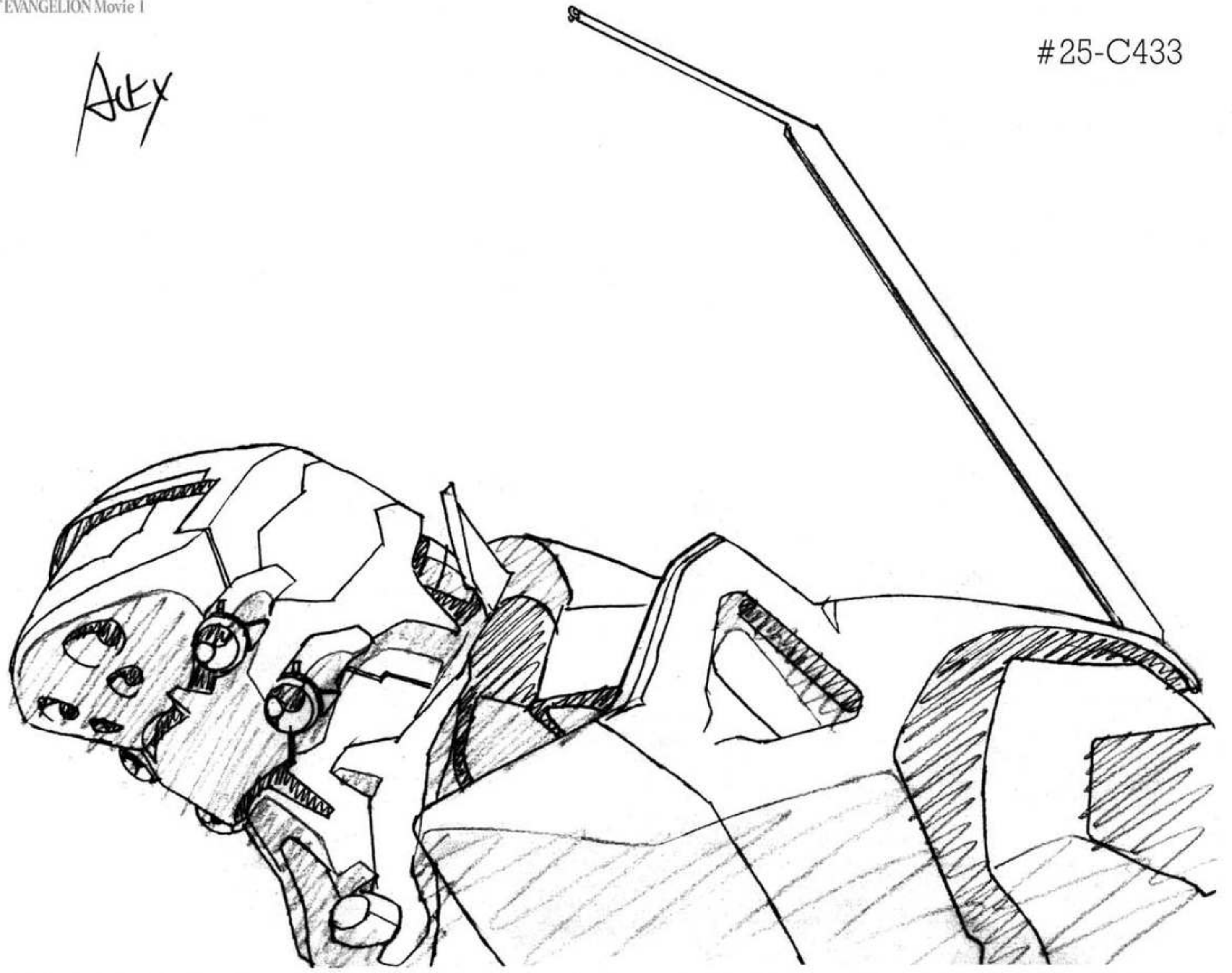



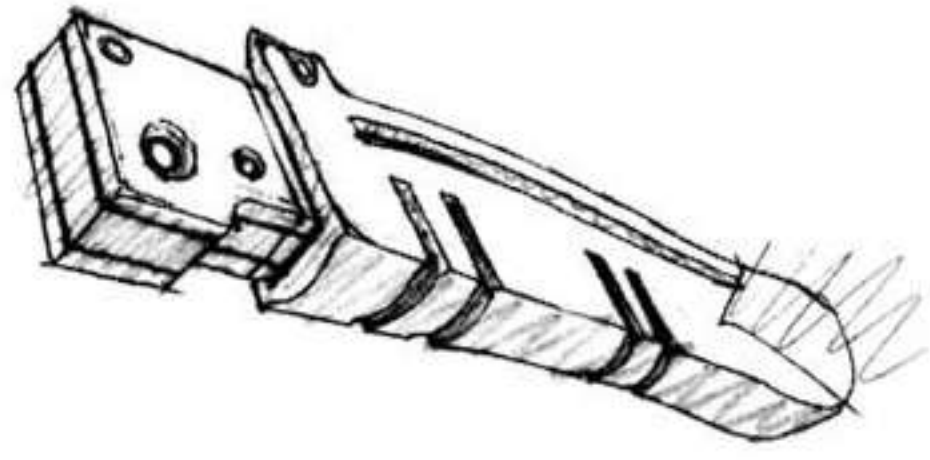

(C2)

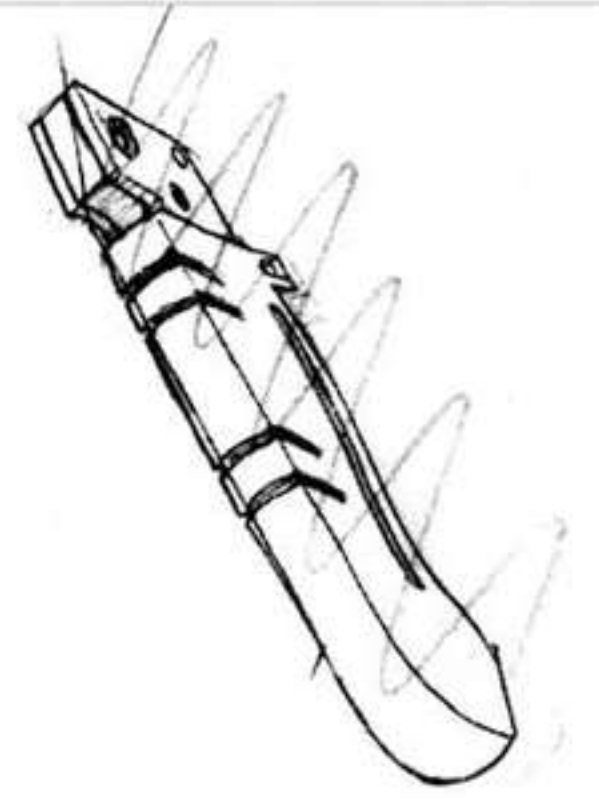

(C1)

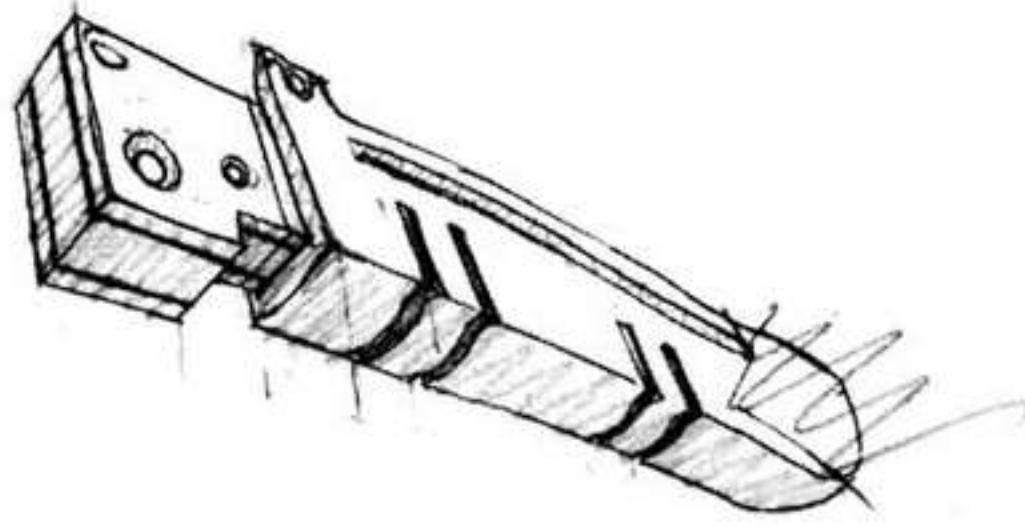

↑R

(C3)

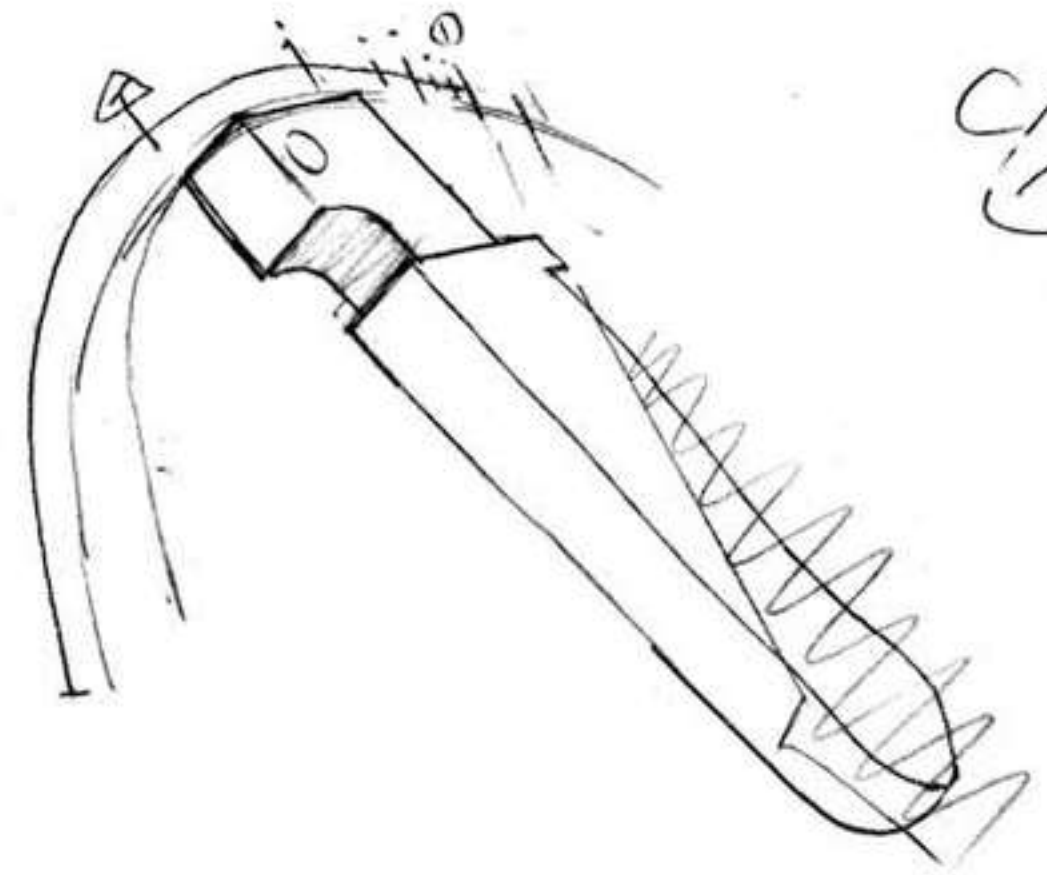

(C4)

A	B	C	
0	0		
1			2
2			4
3			6
4			8
5			10
6			12
7			14
8			16
9			18
10			20
11			22
12			24
13			26
14			28
15			30
16			32

タイムシート

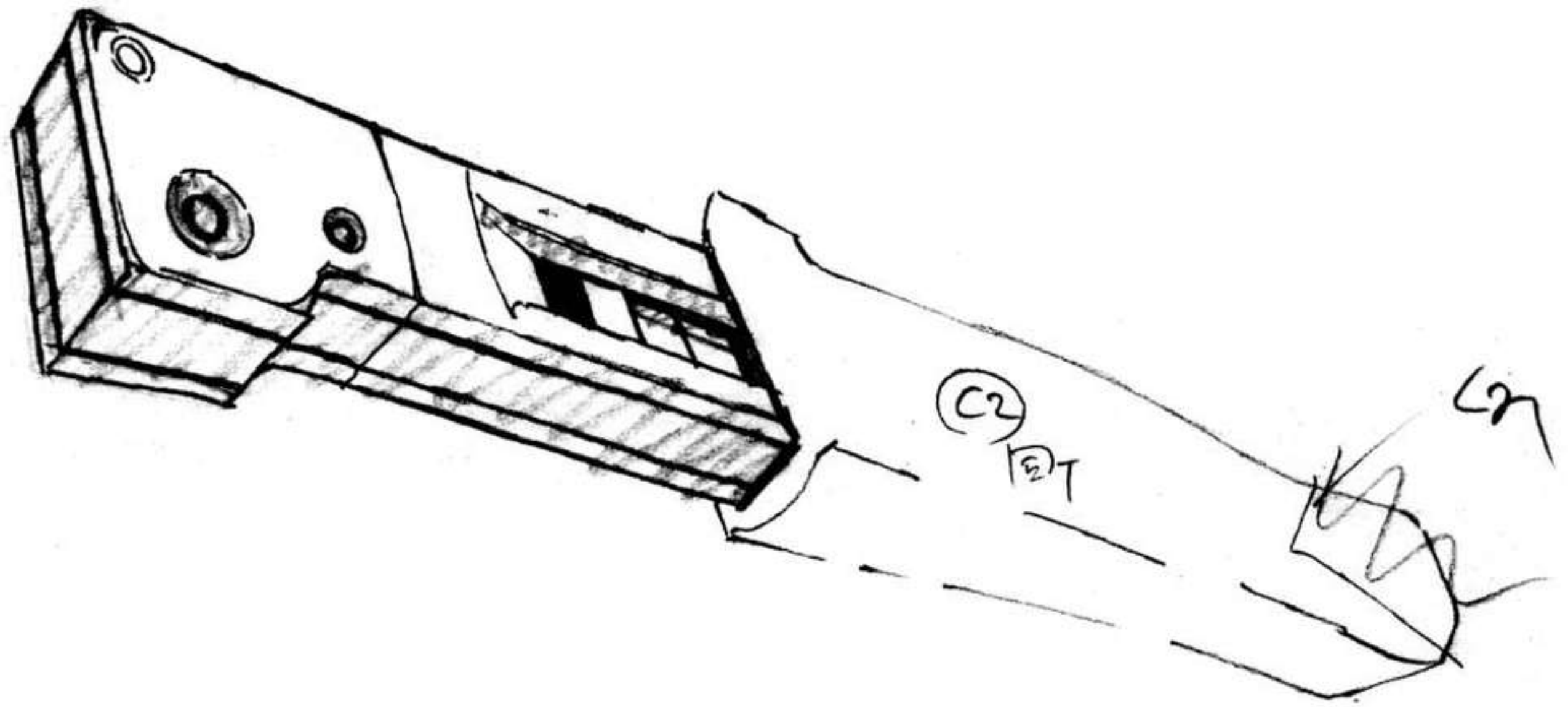

(C2) END

C2

(C4) END



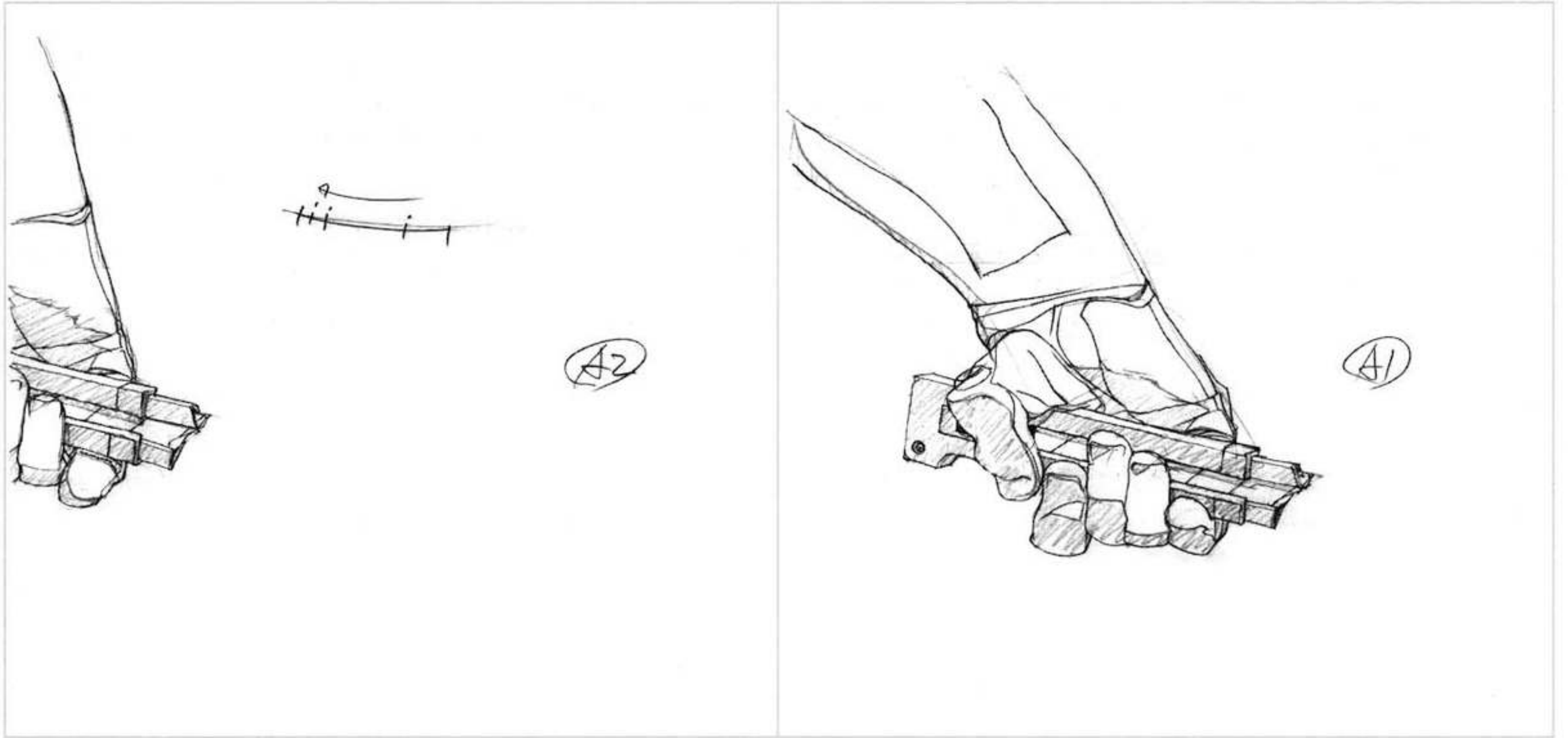

#25-C437

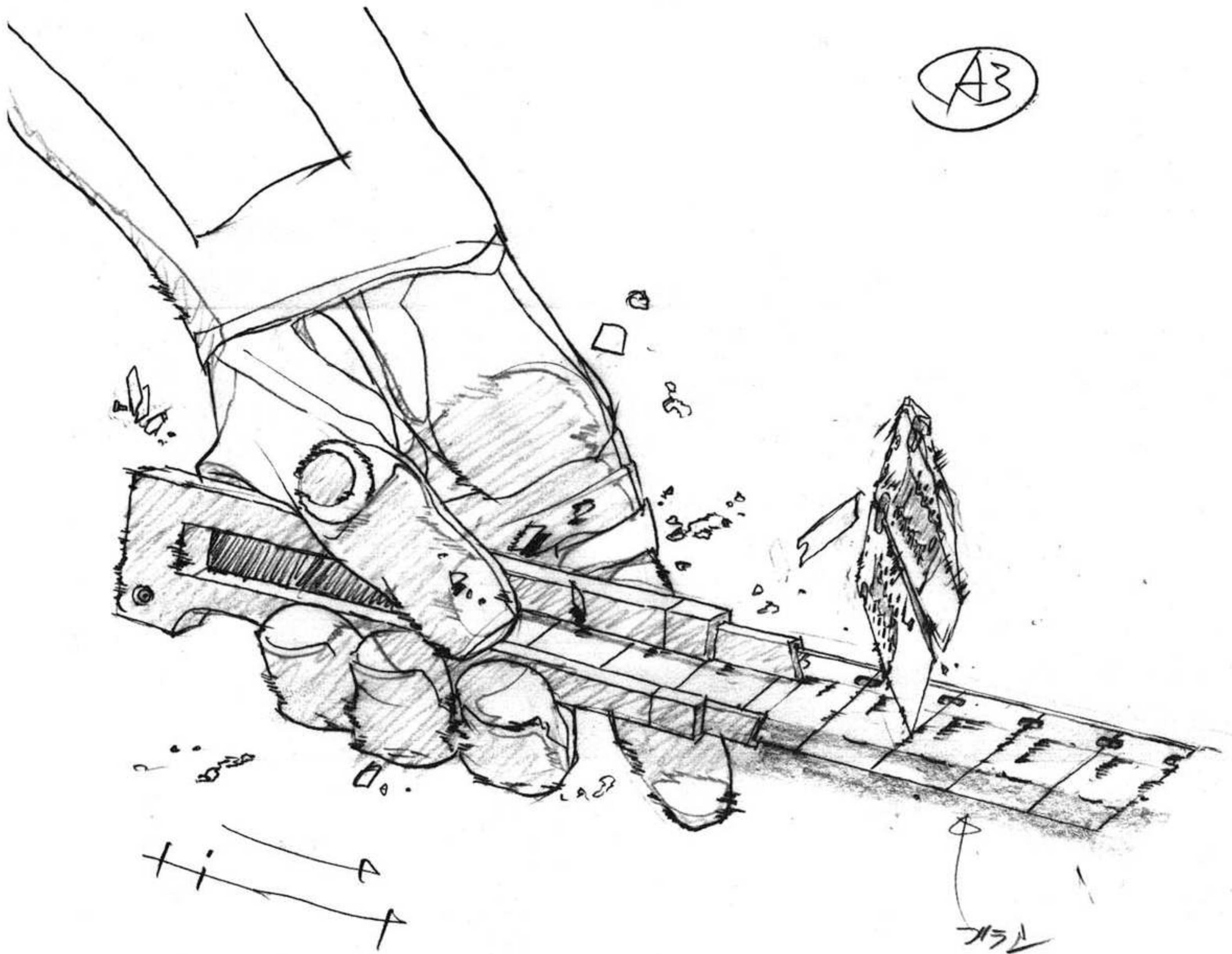







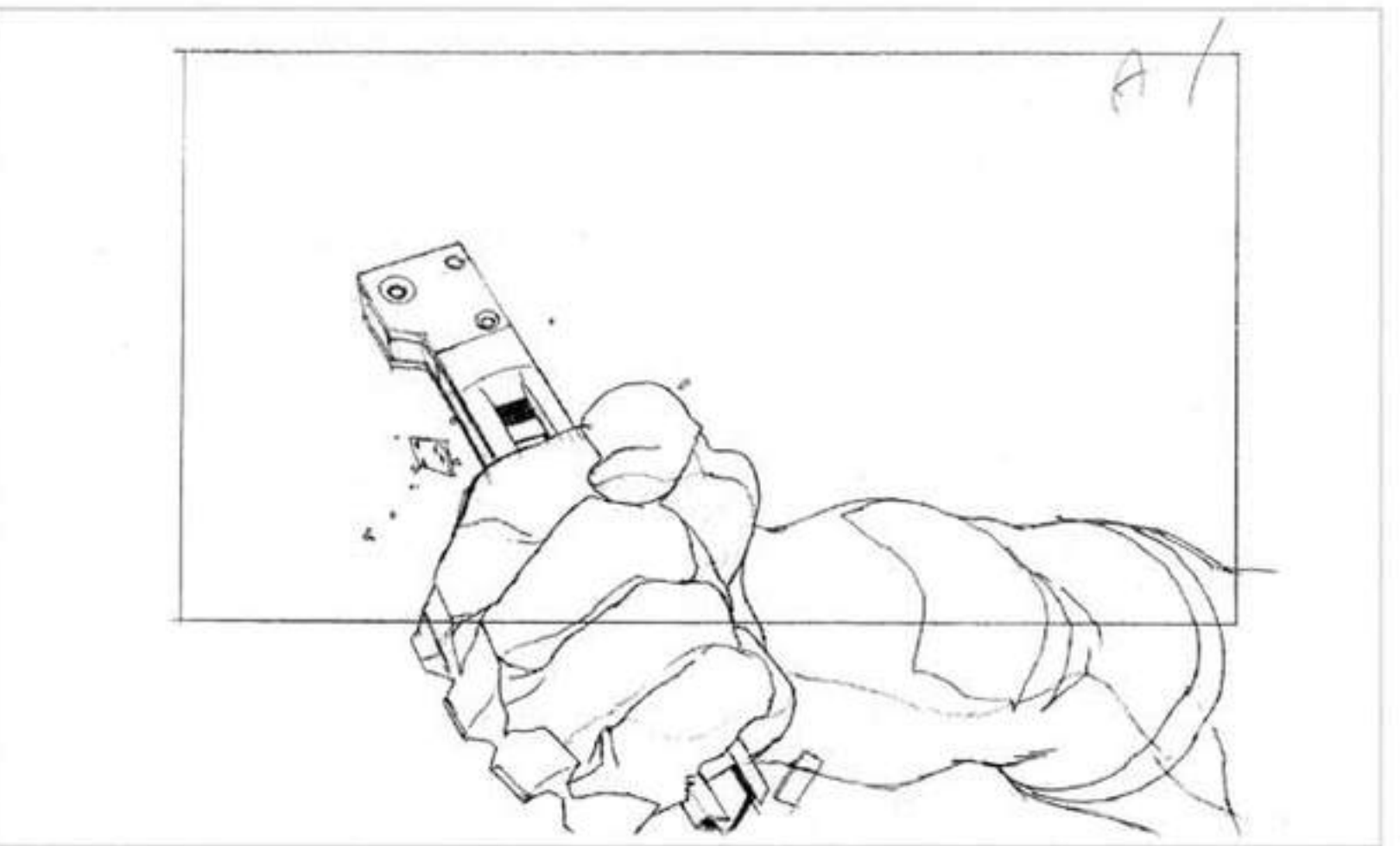
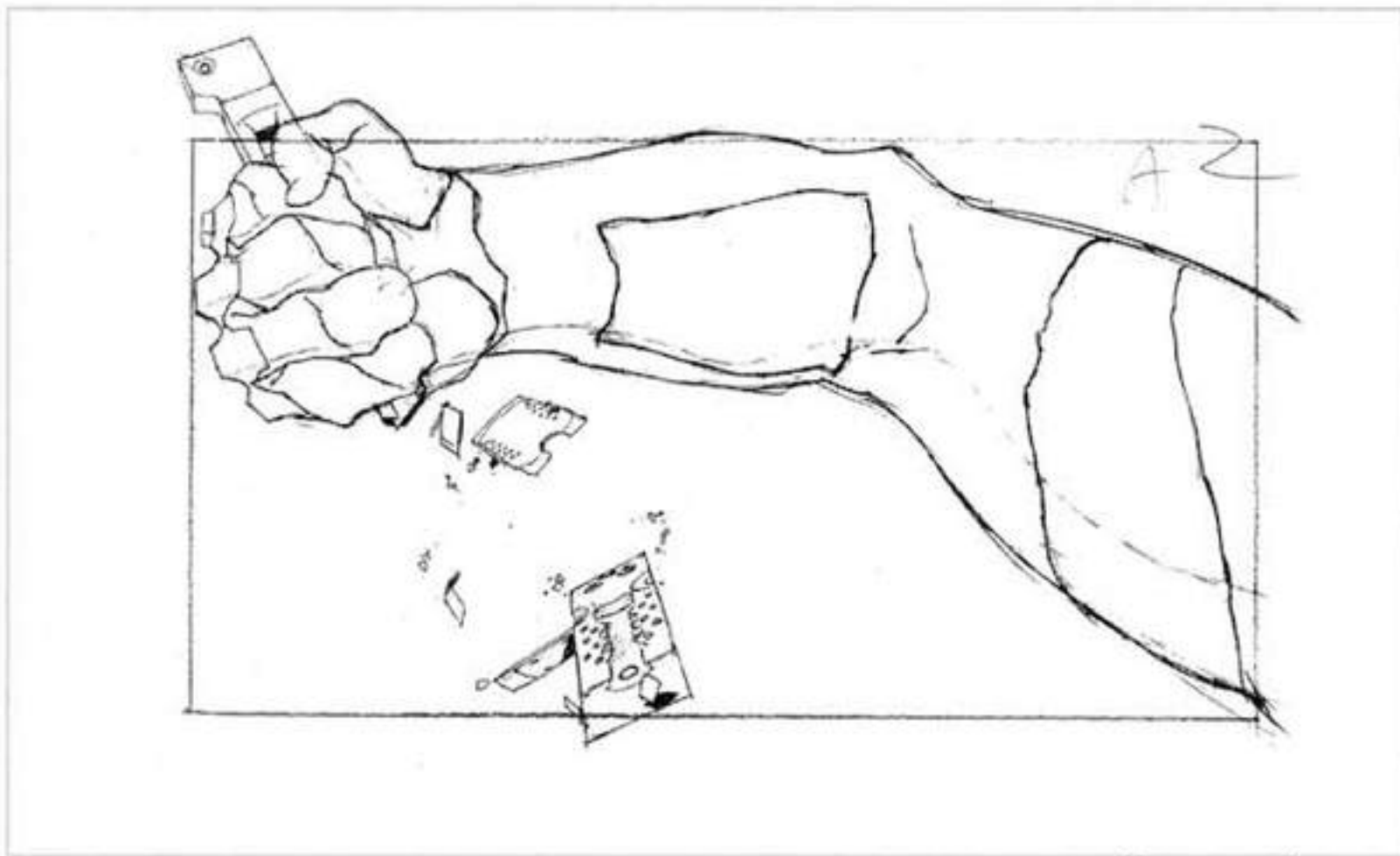

#25-C441

1	
2	2
3	4
4	6
5	8
6	10
7	12
8	14
9	16
10	18
11	20
12	22
13	24
14	26
15	28
16	30
17	32
18	34
19	36

タイムシート

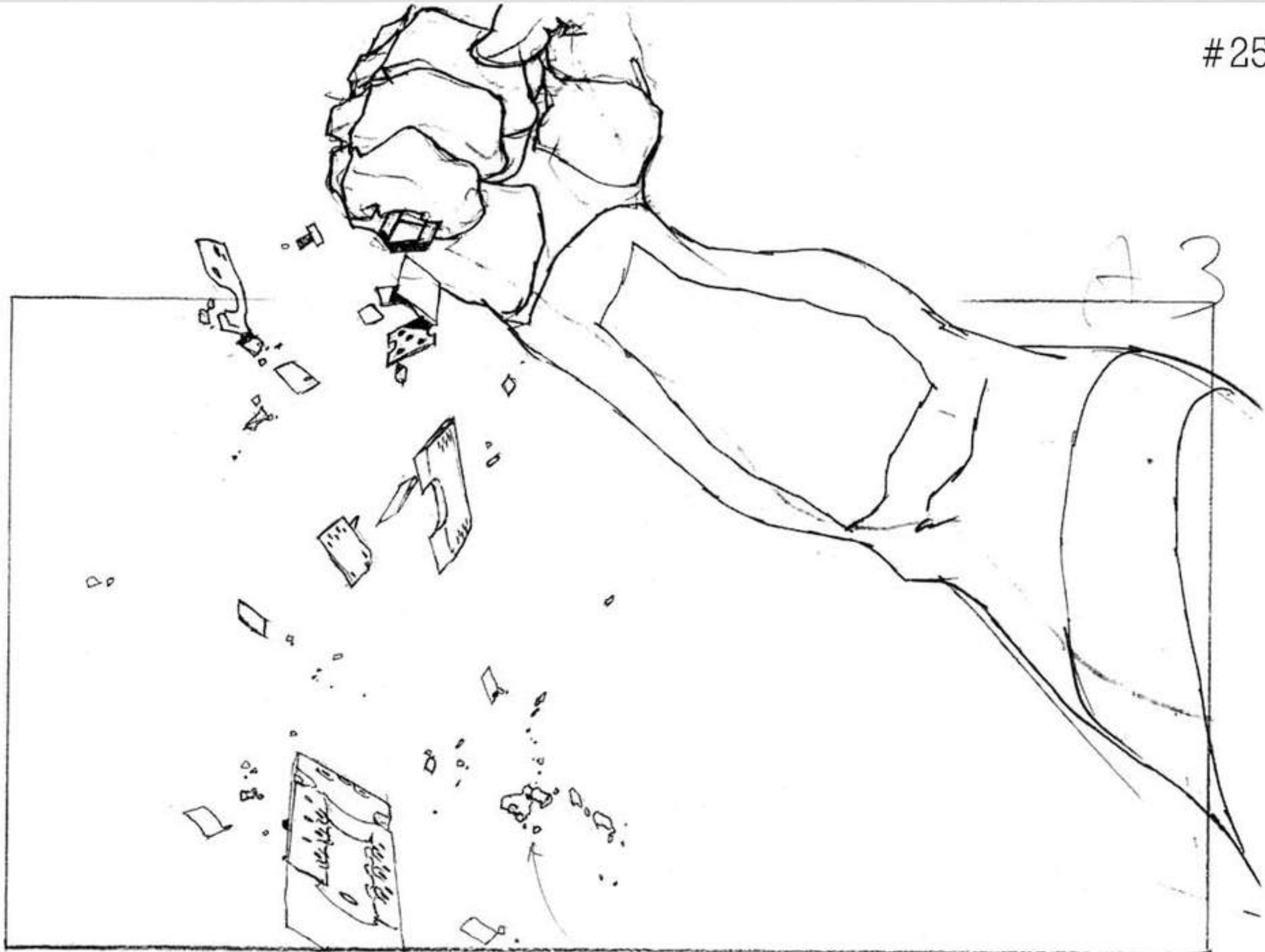

60E 73.  
 ニジロシ 表現のため  
 ぶたつた. 7.2.2. 1.7.1.2.4.4  
 7.2.2. 1.7.1.2.4.4  
 2.7.2. 1.7.1.2.4.4  
 2.7.2. 1.7.1.2.4.4  
 2.7.2. 1.7.1.2.4.4

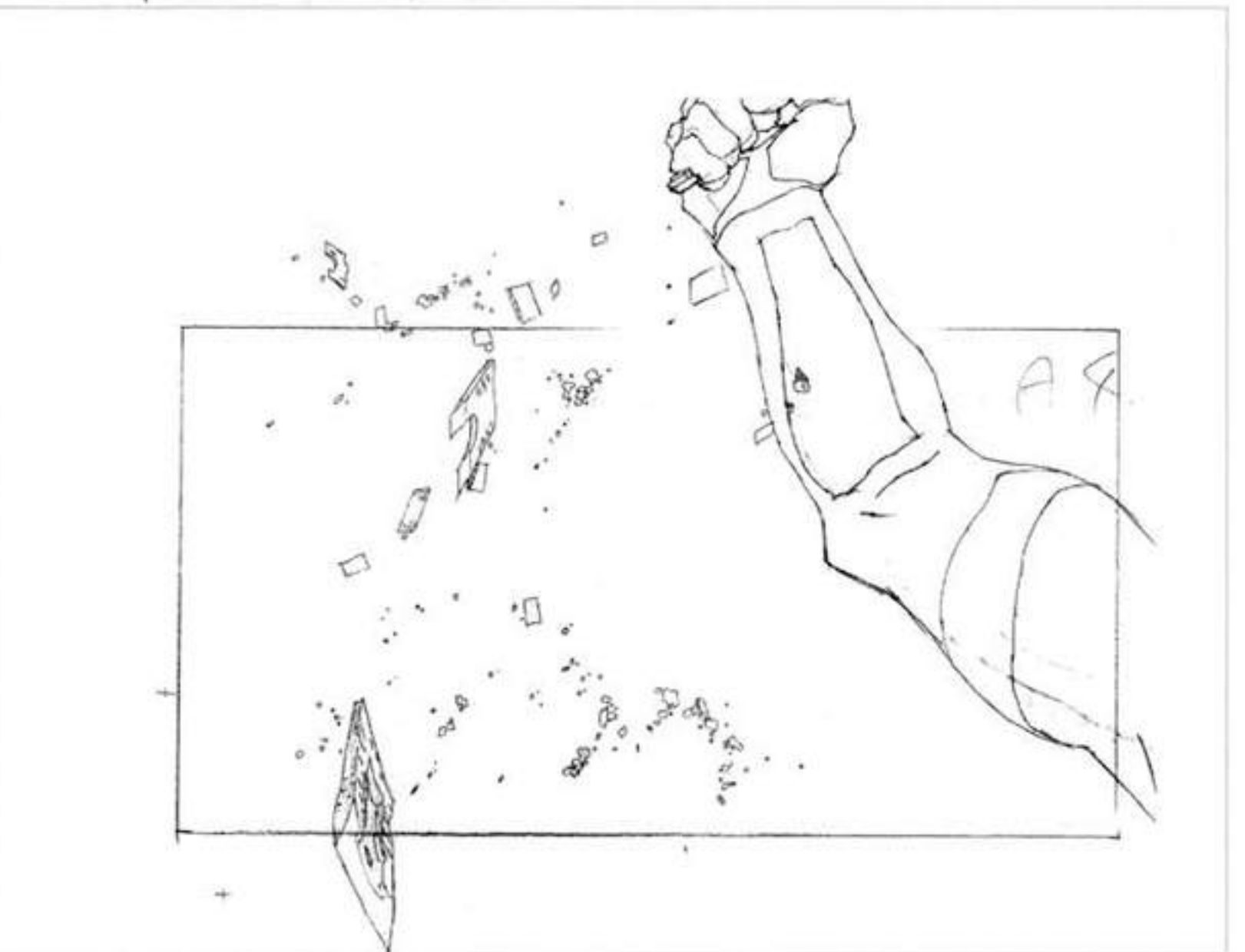
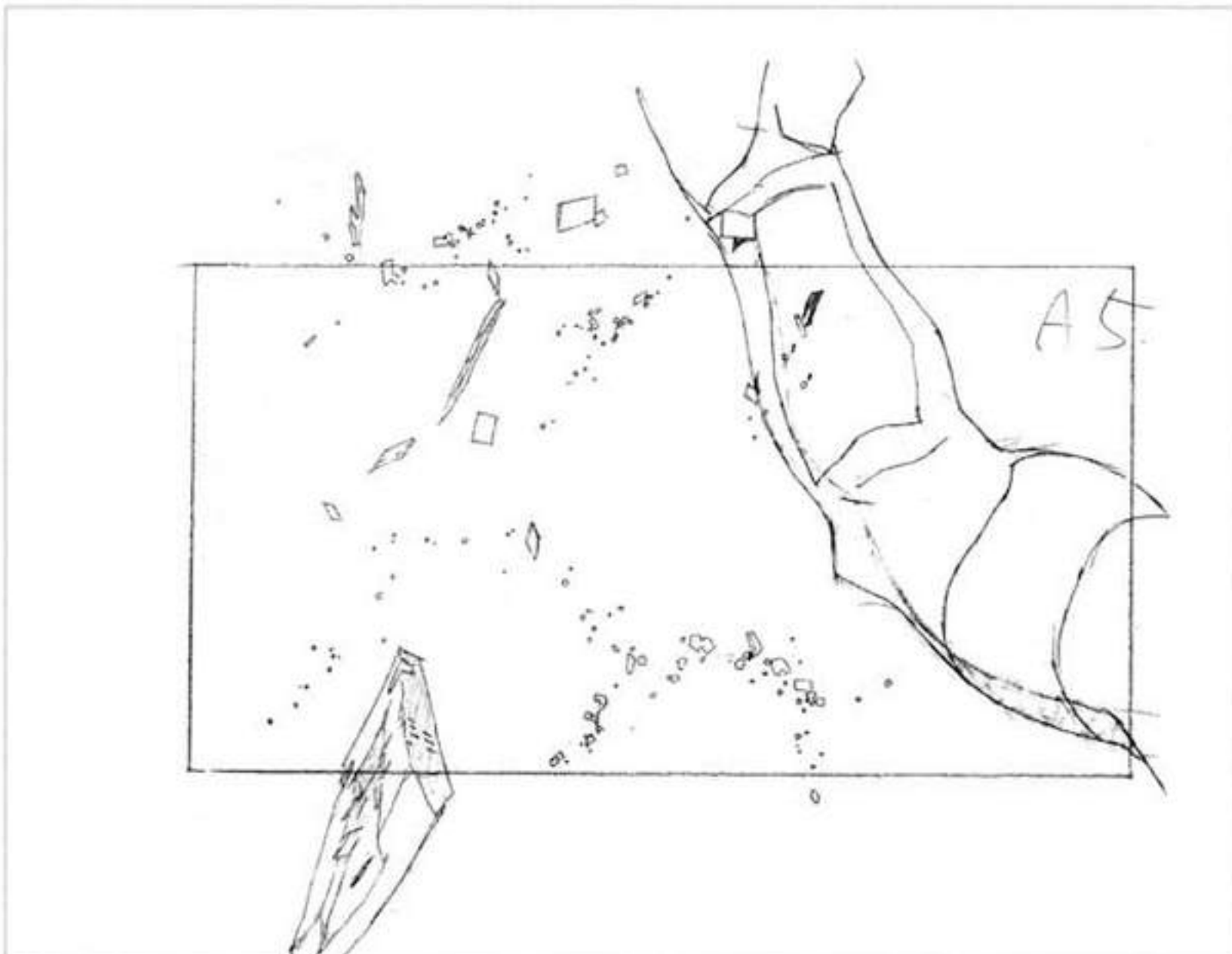



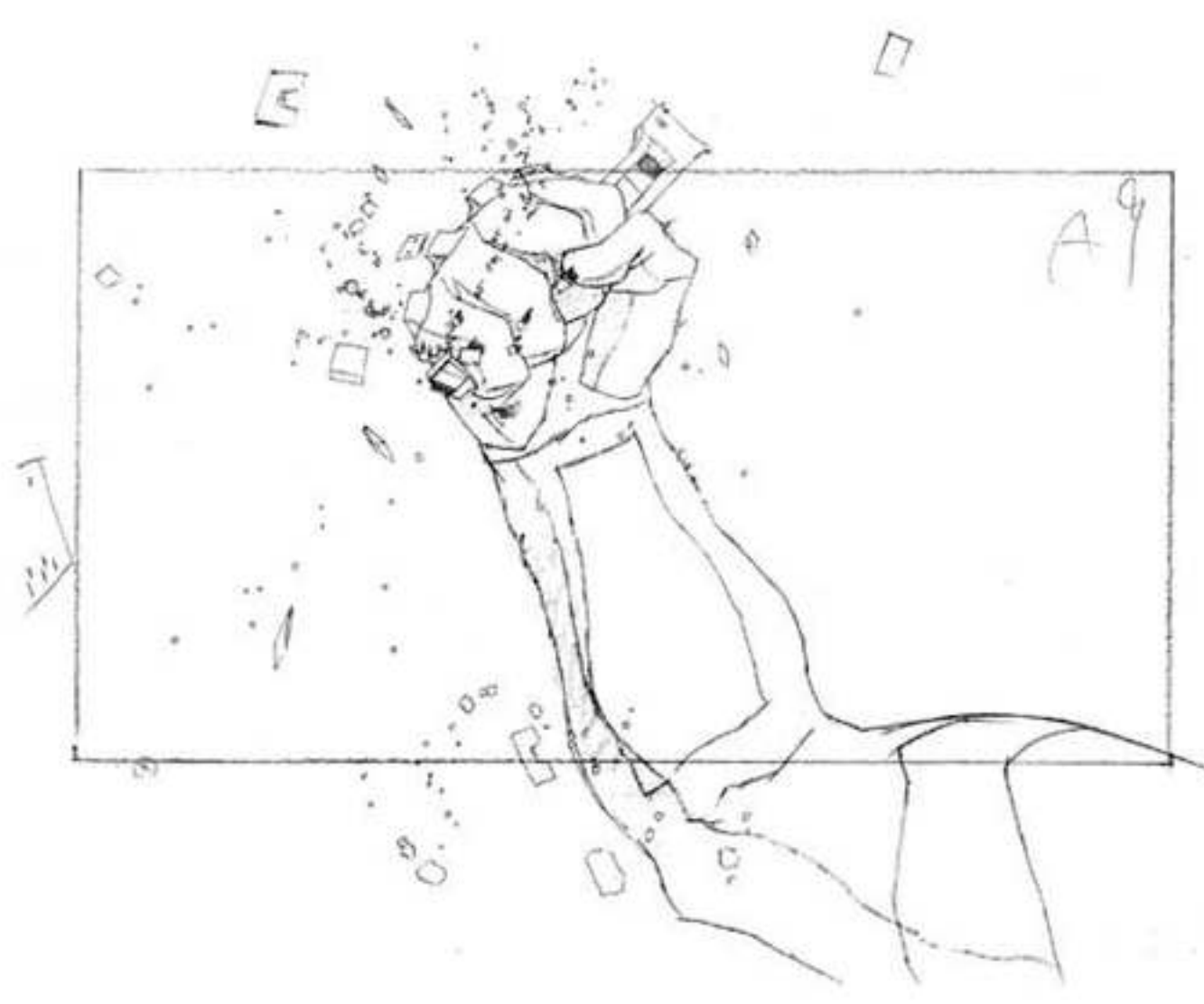

A9

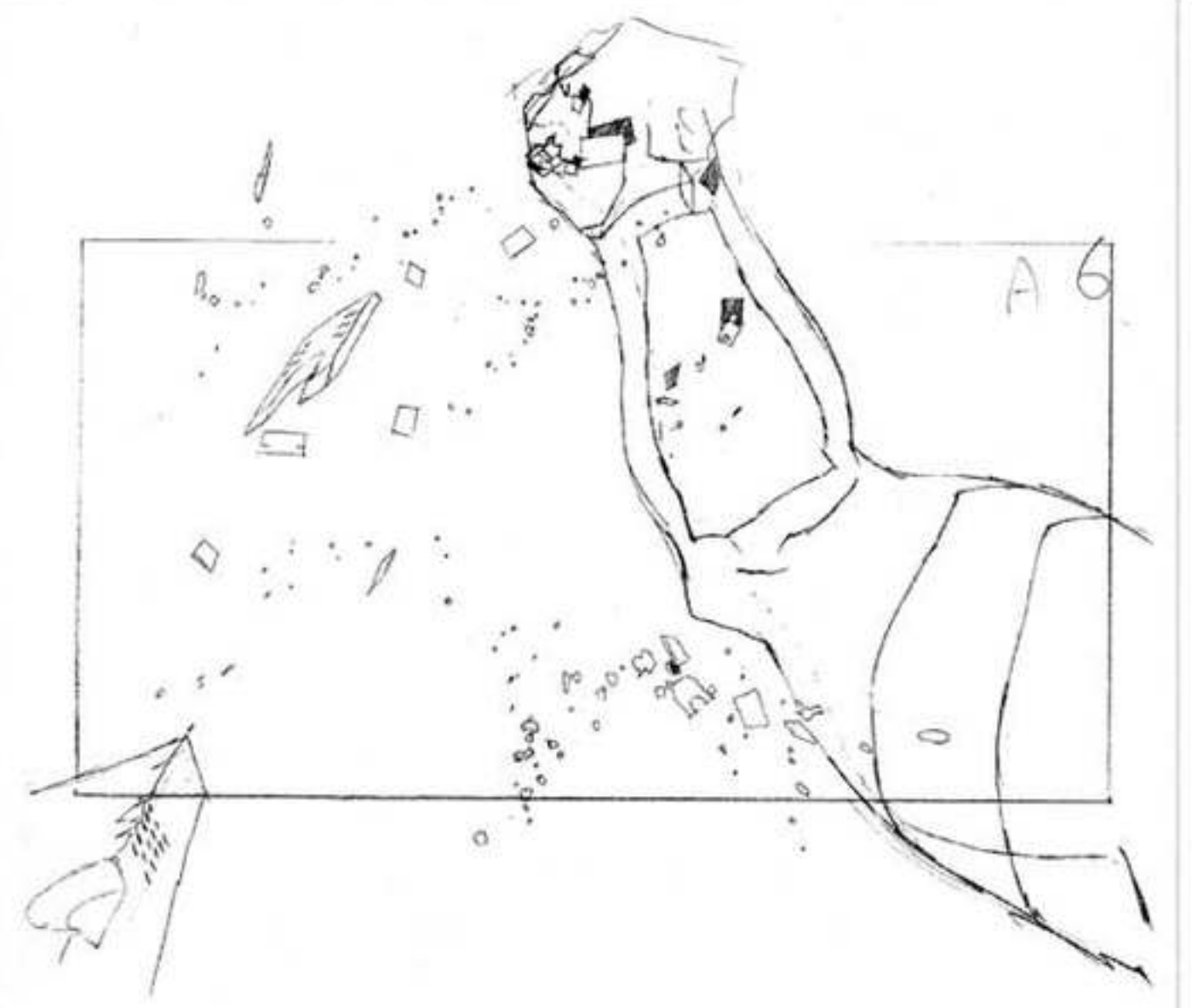

A6

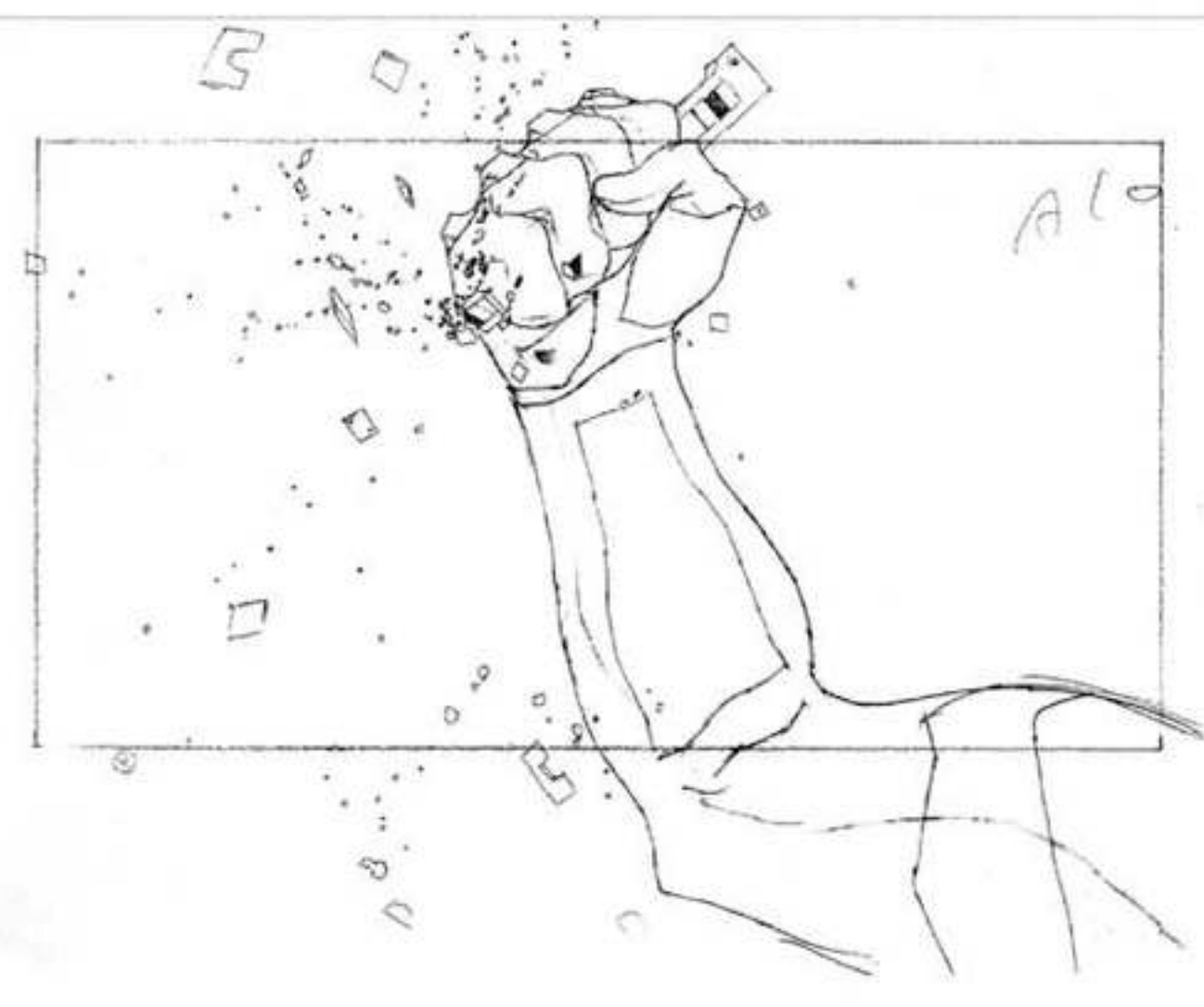

A10

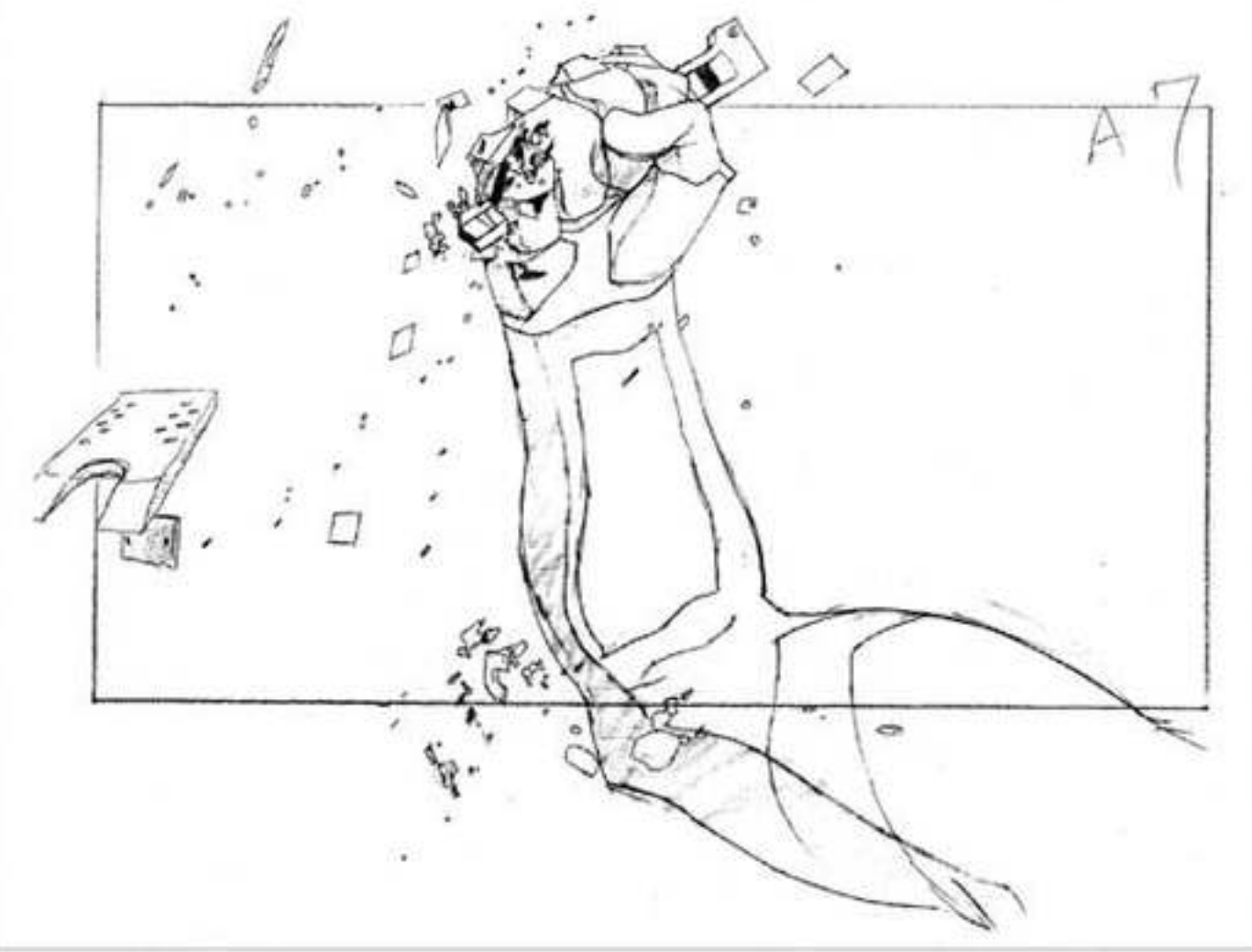

A7

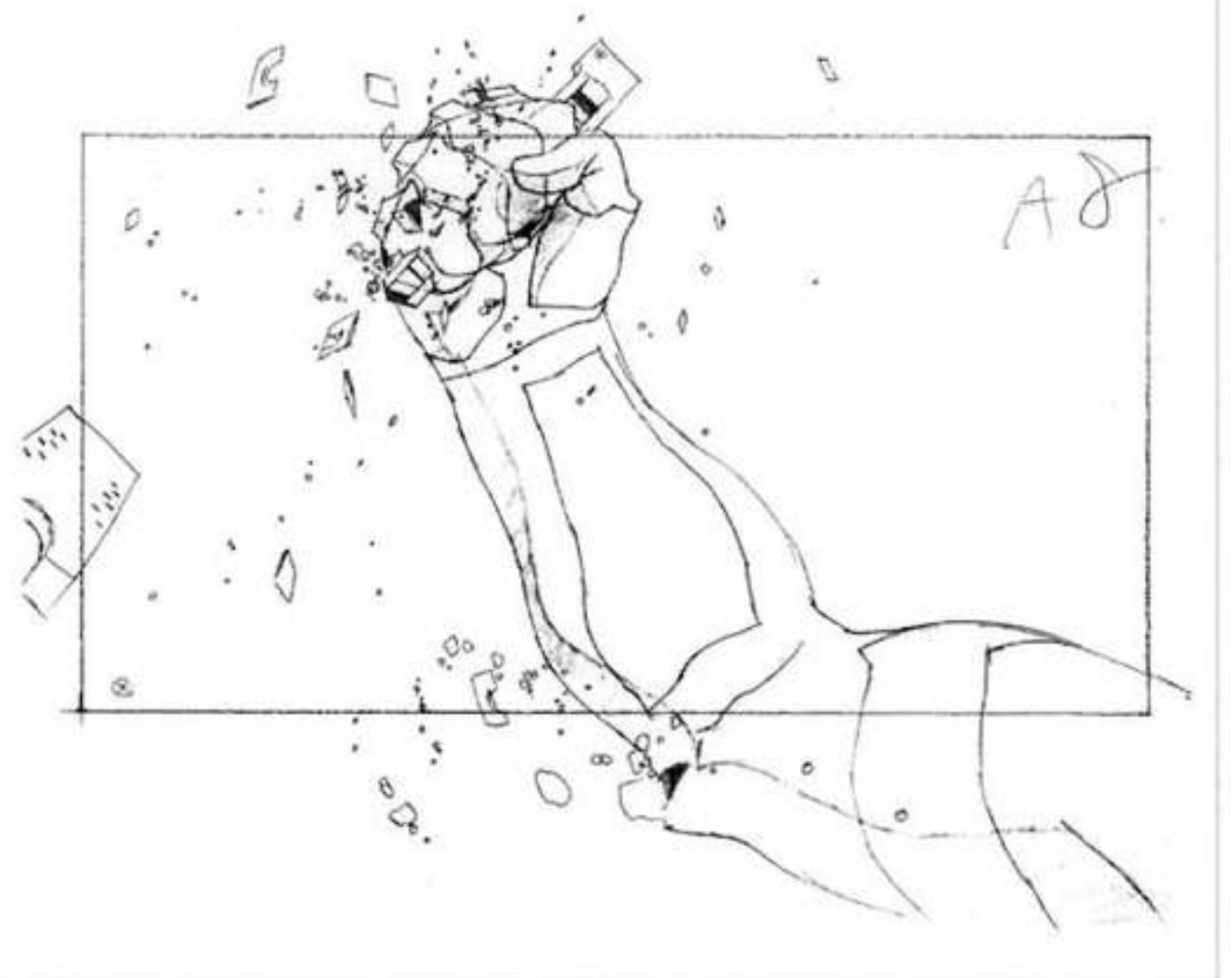

A8

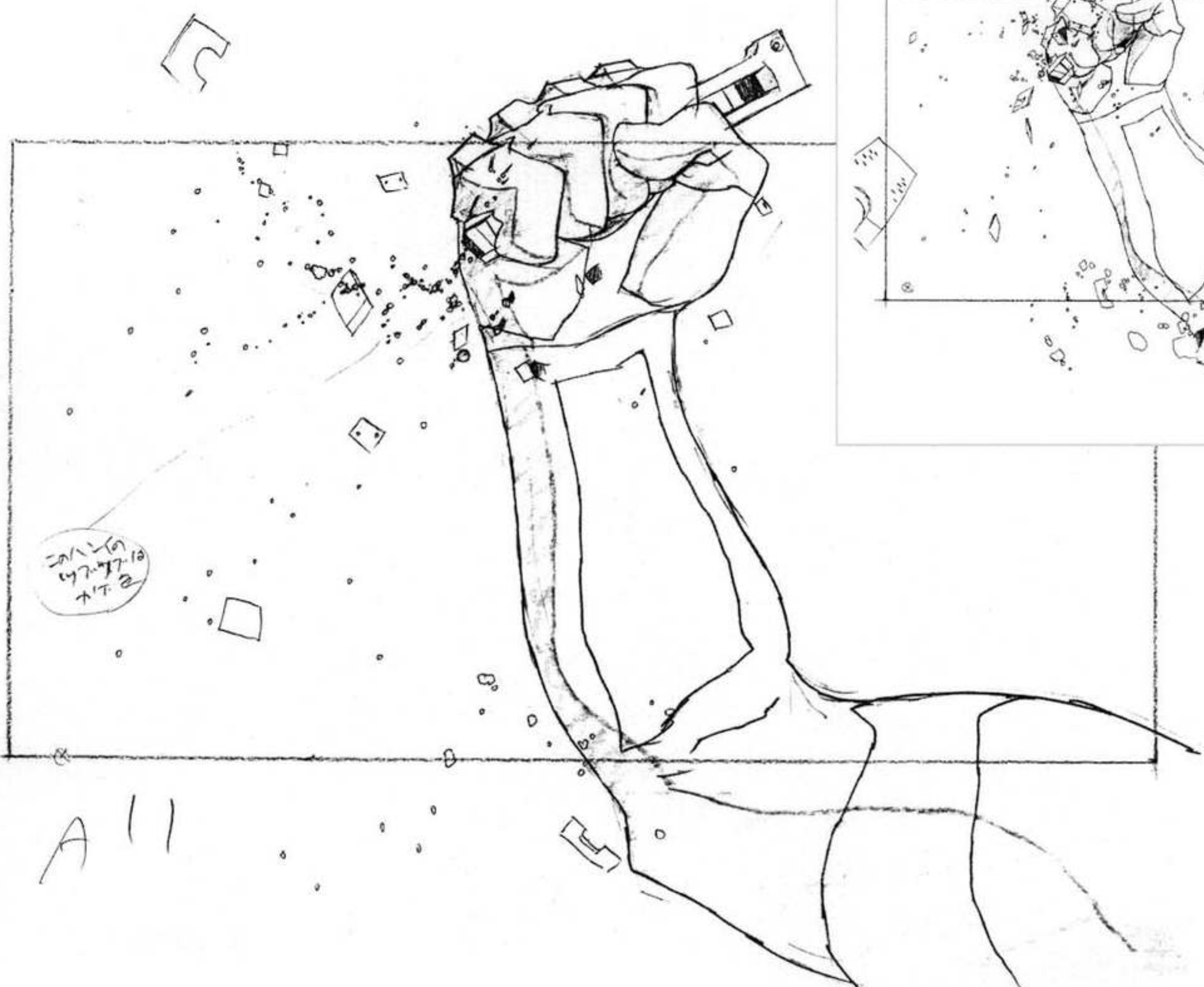

A11



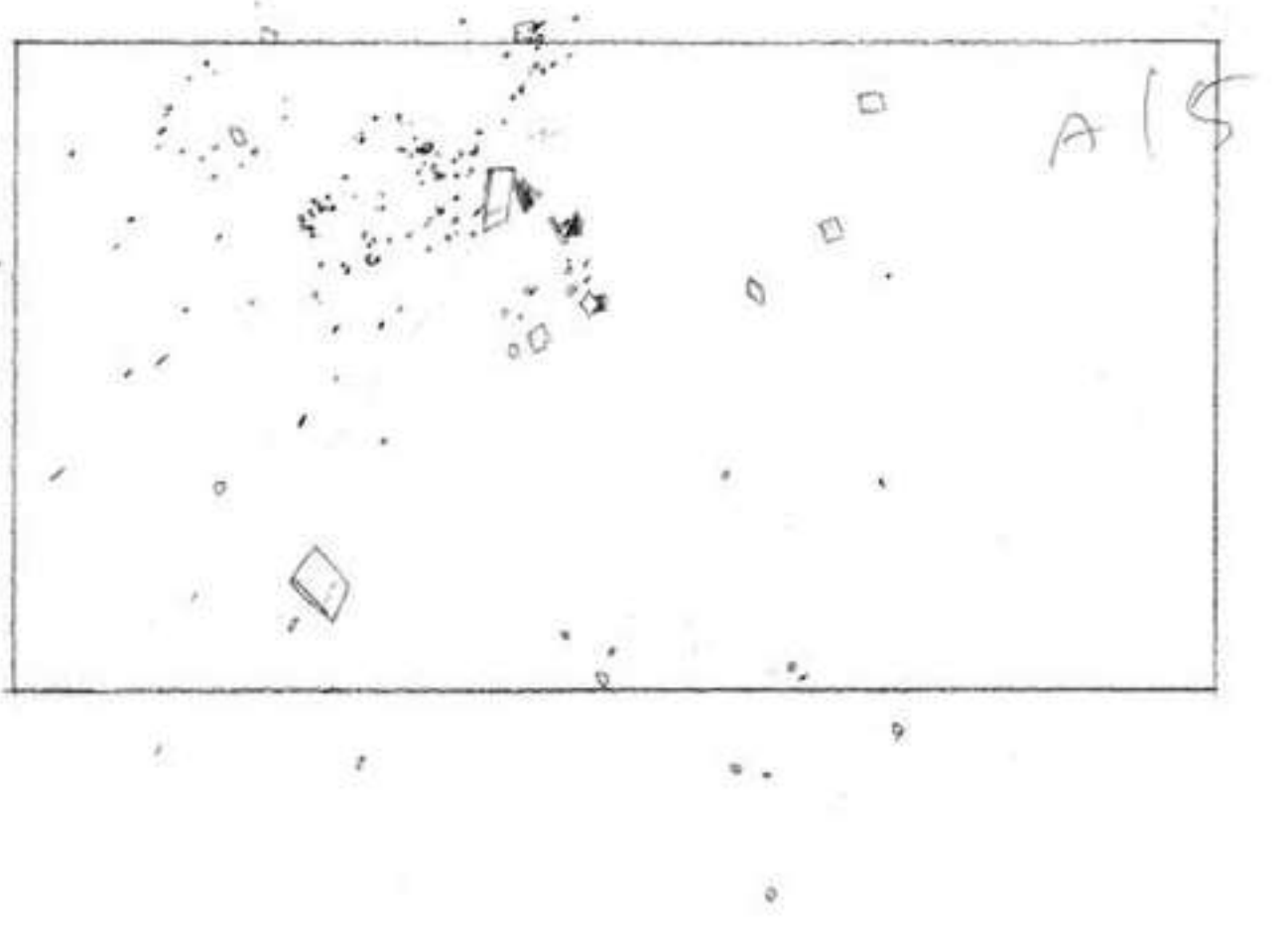
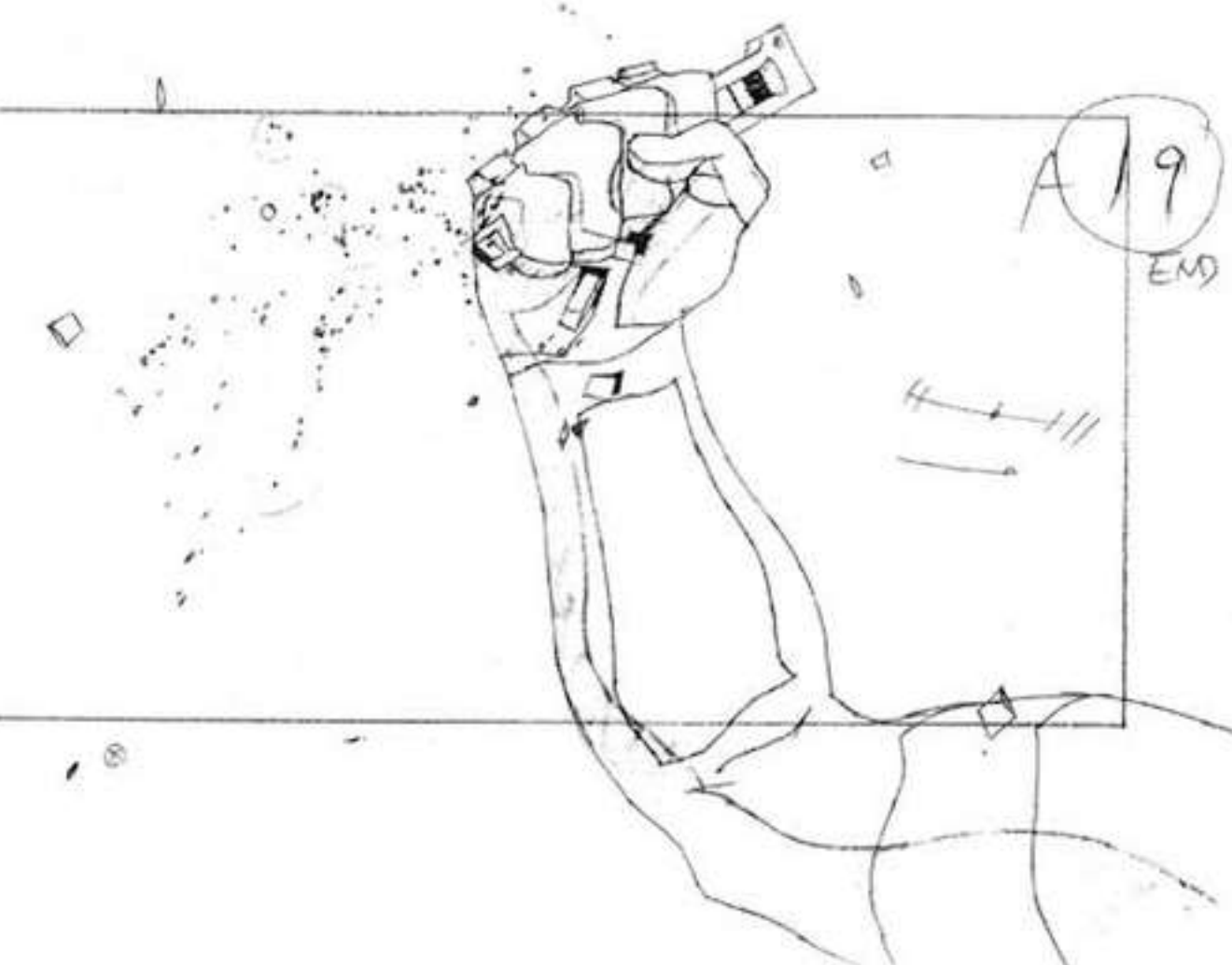
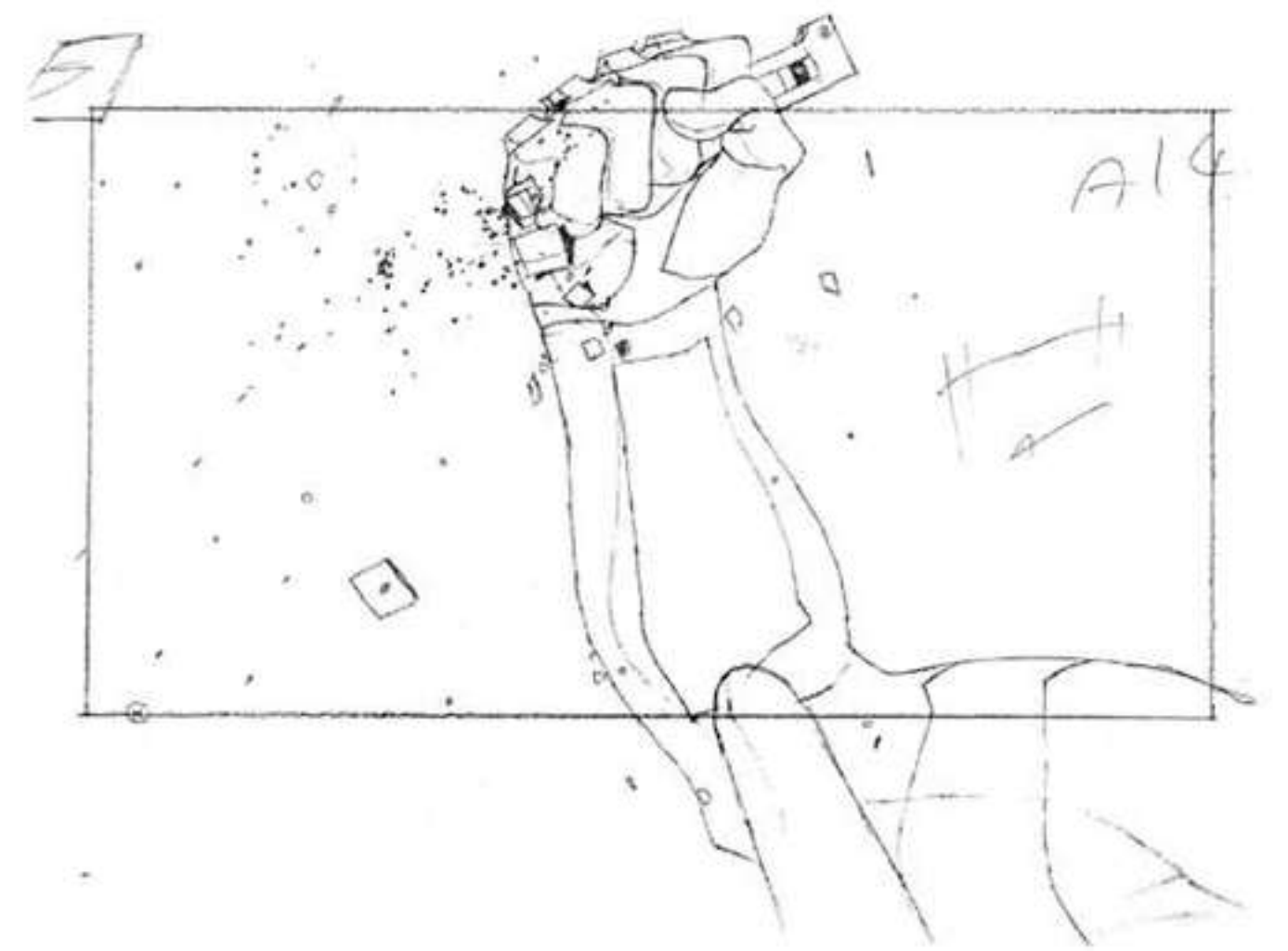
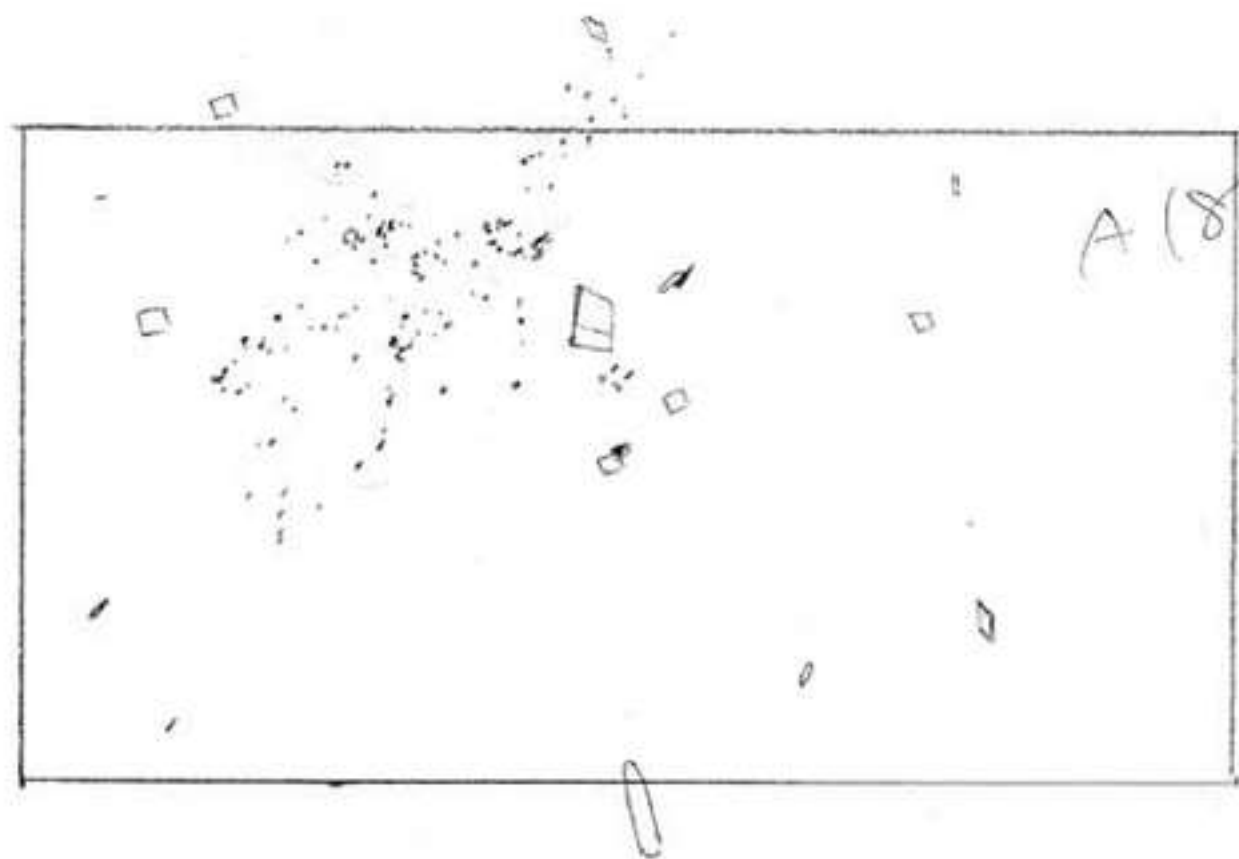
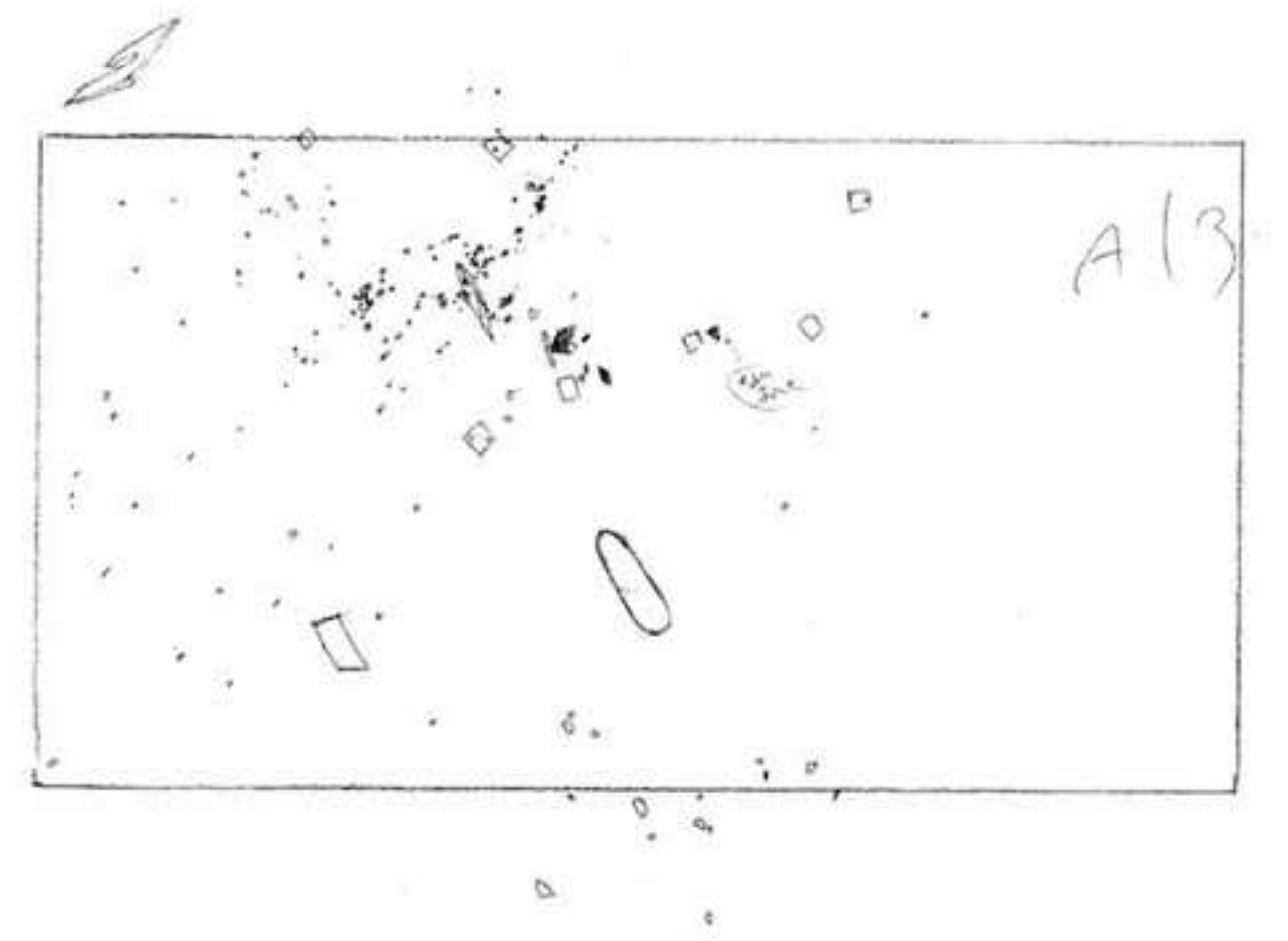
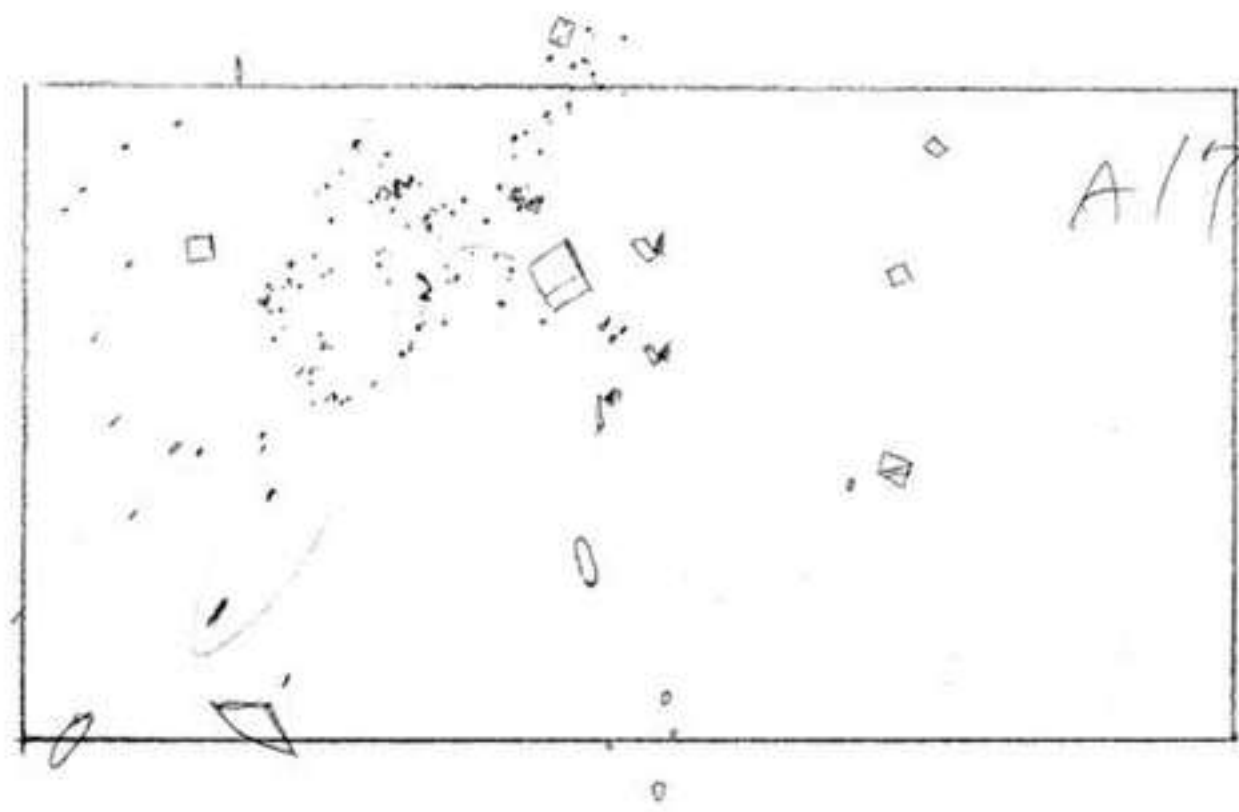
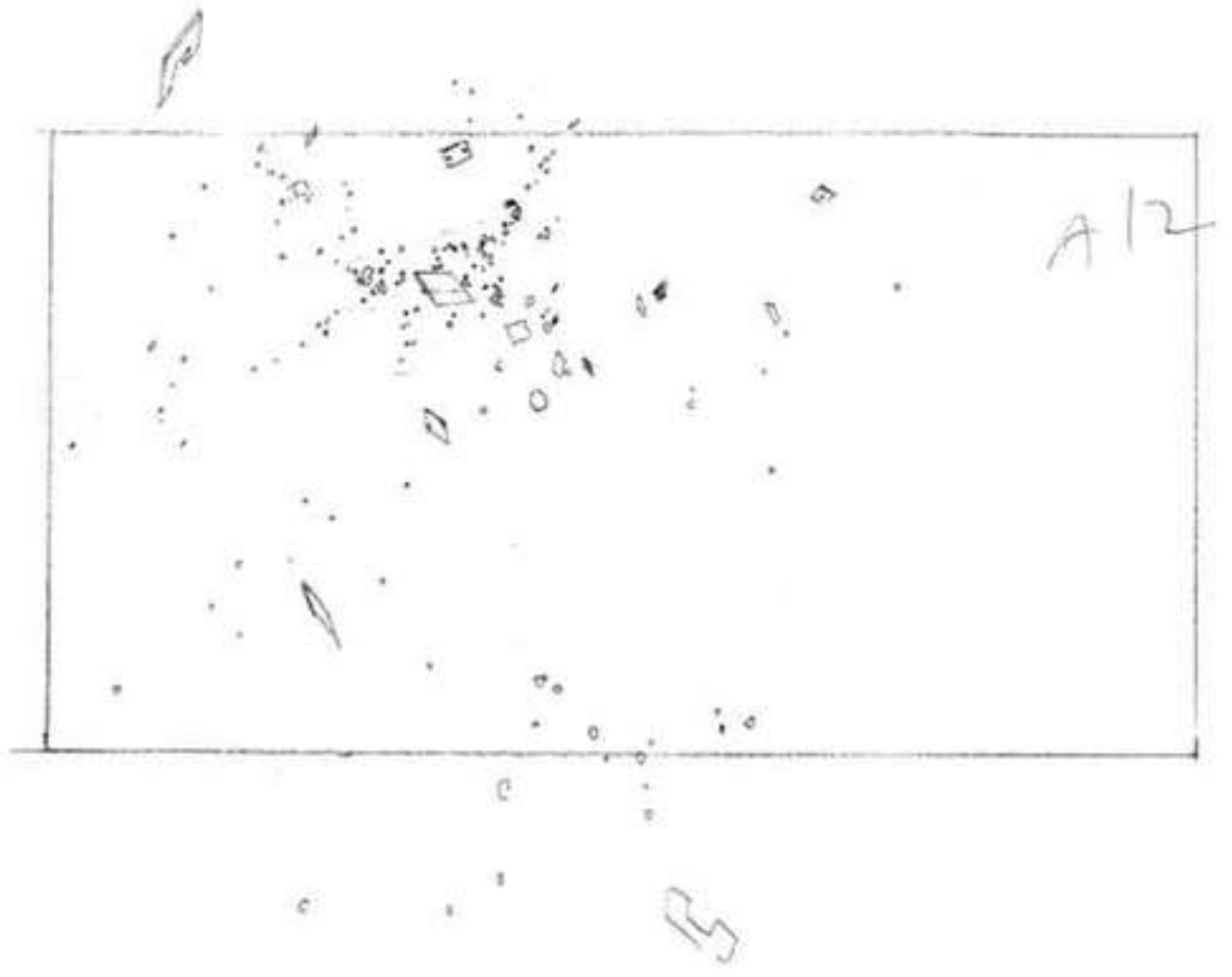
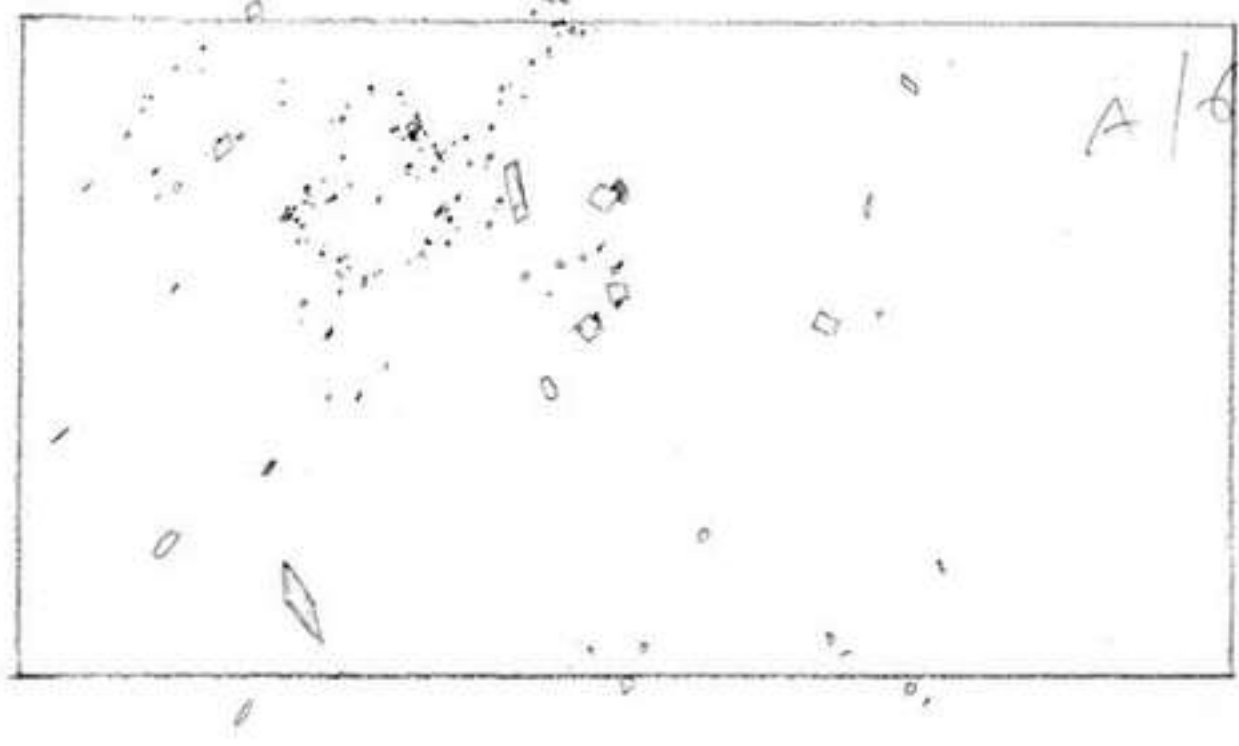







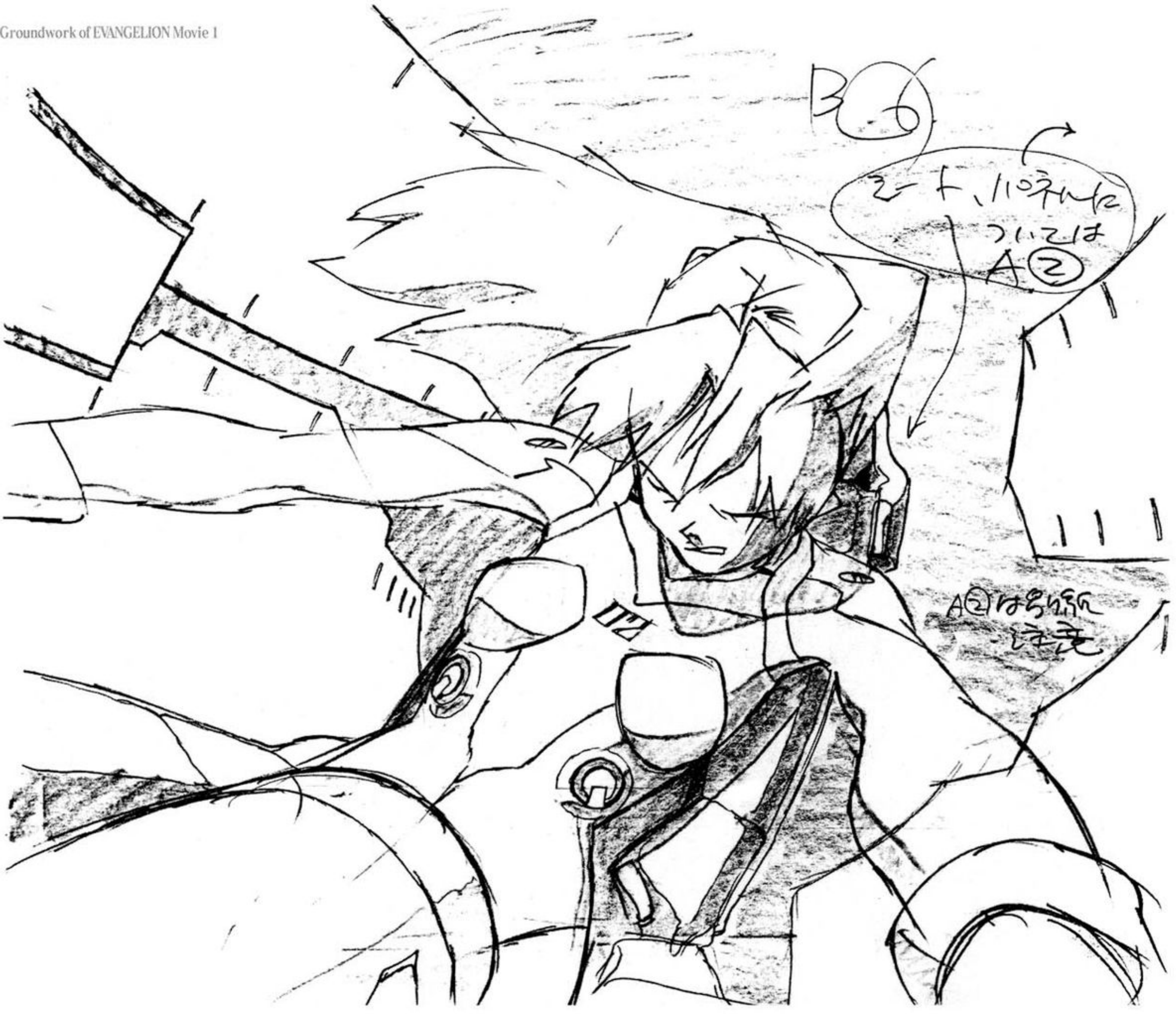



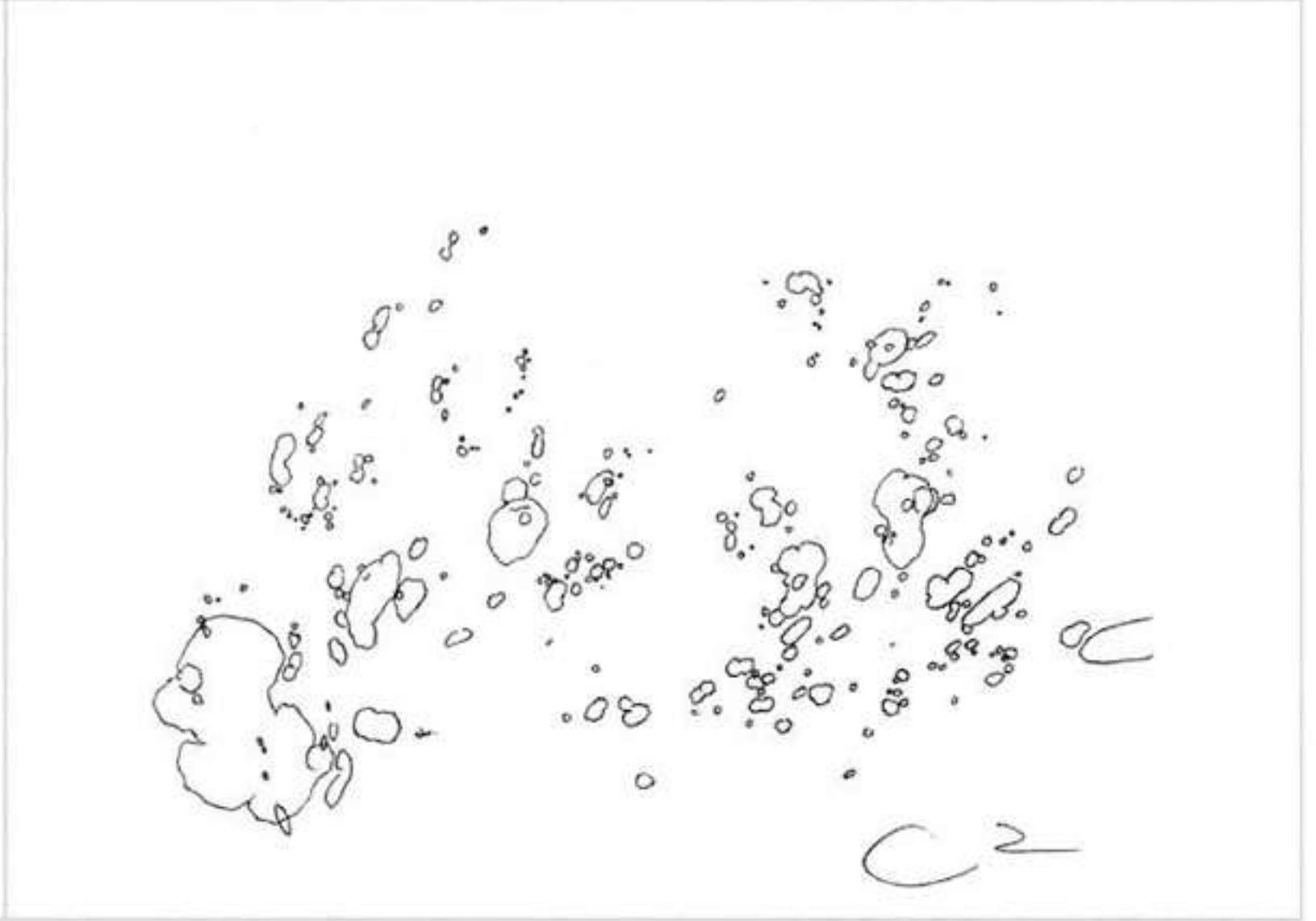
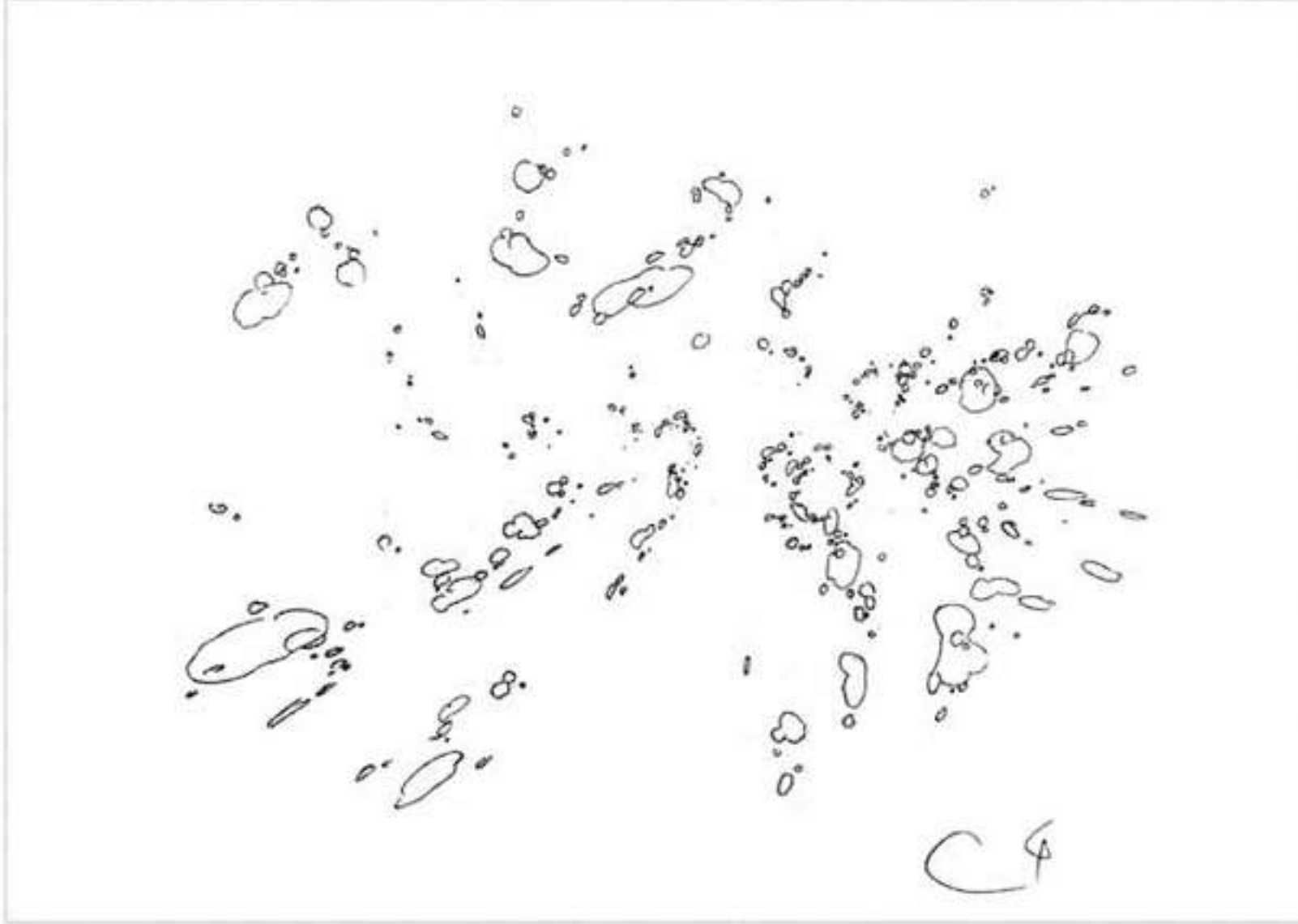
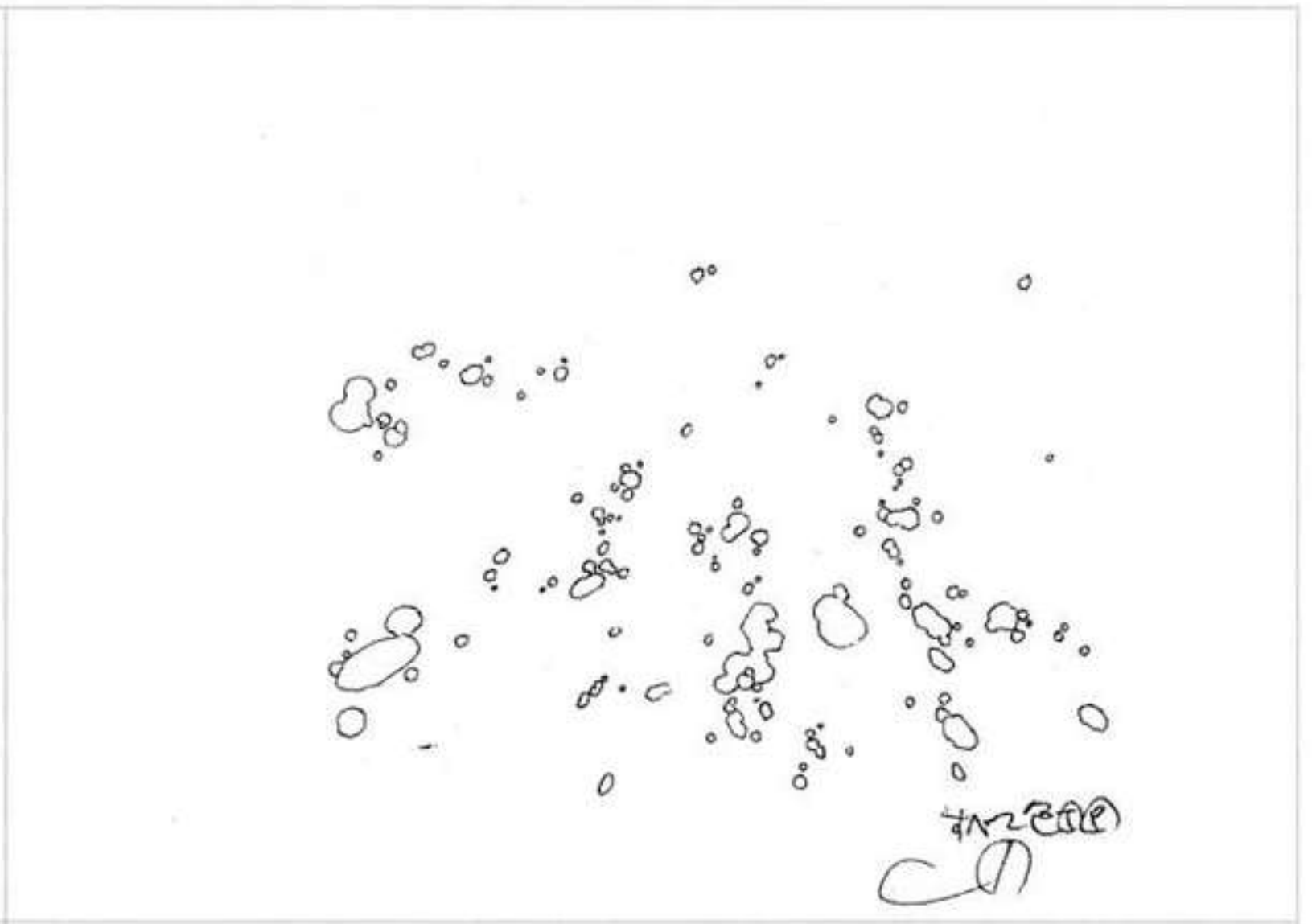

	A	B	C	D	
①	1	x	x		2
	/				4
②					6
③					8
	/				10
	/				12
	/				14
	/				16
	⊙				18
	/				20
④	1	1			22
⑤	2	2			24
⑥	3	3			26
⑦	4	4			28
⑧	5	5			30

タイムシート

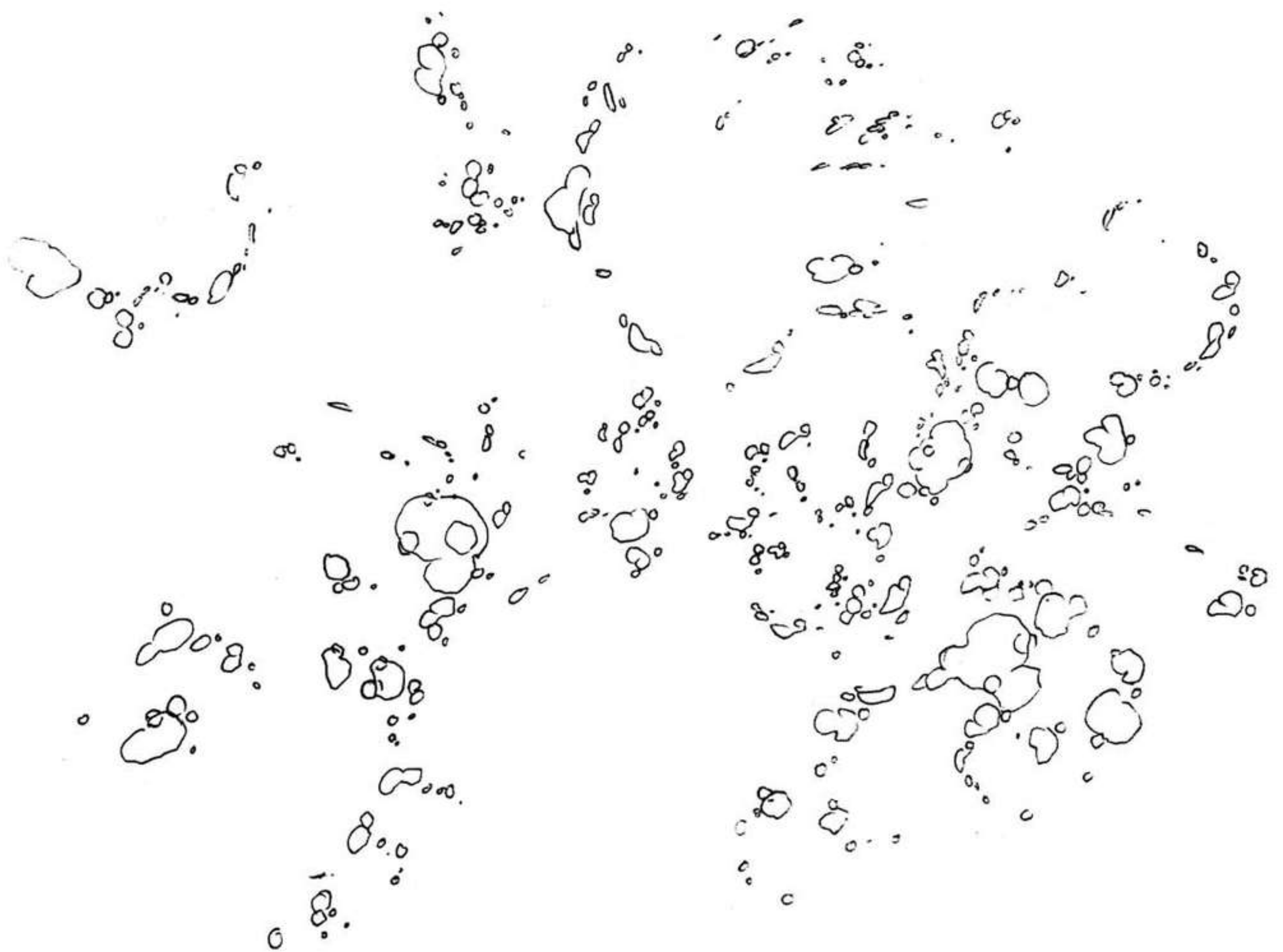



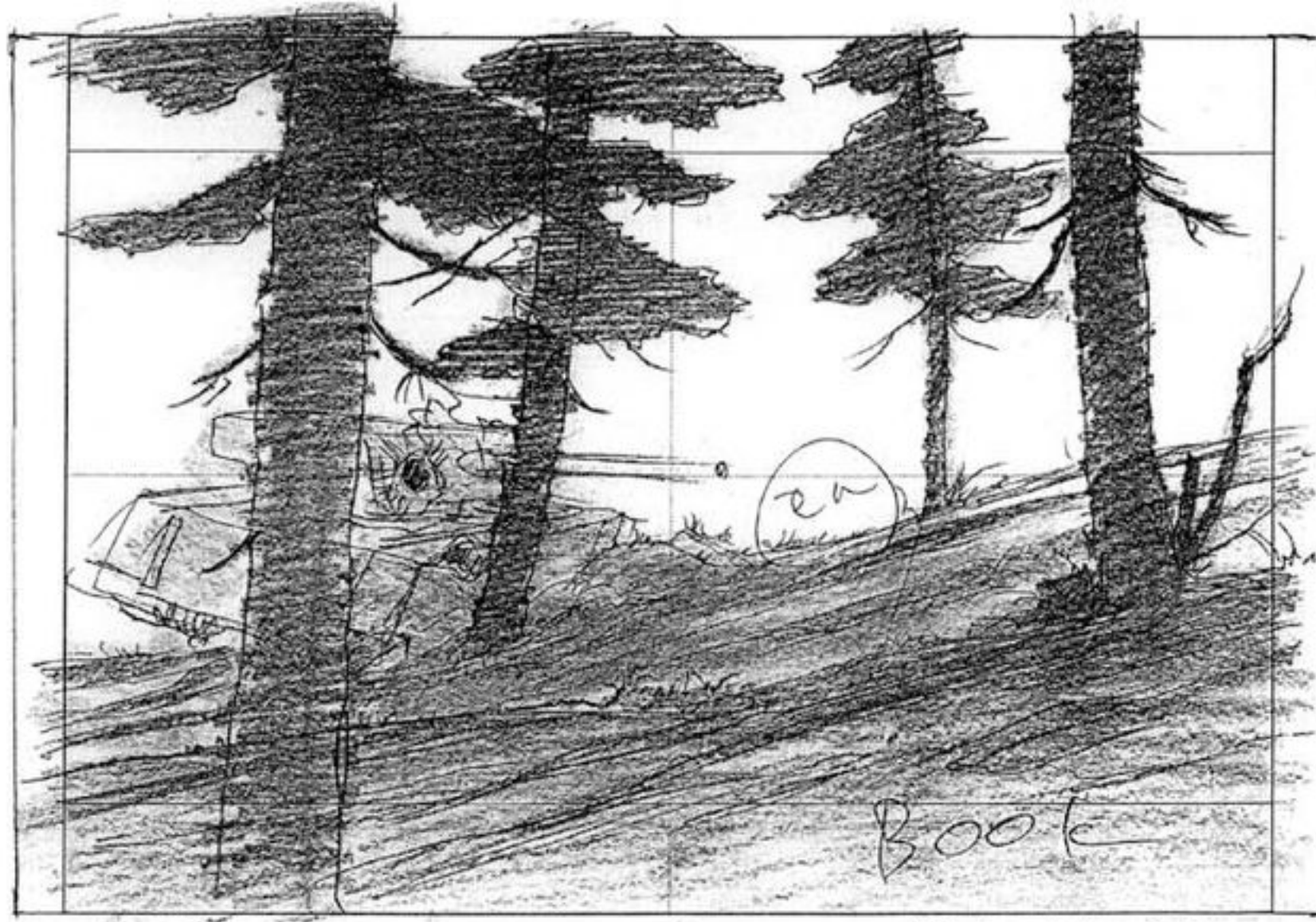

#25-C443

レイアウト

新井の絵巻レイアウト  
2002.11

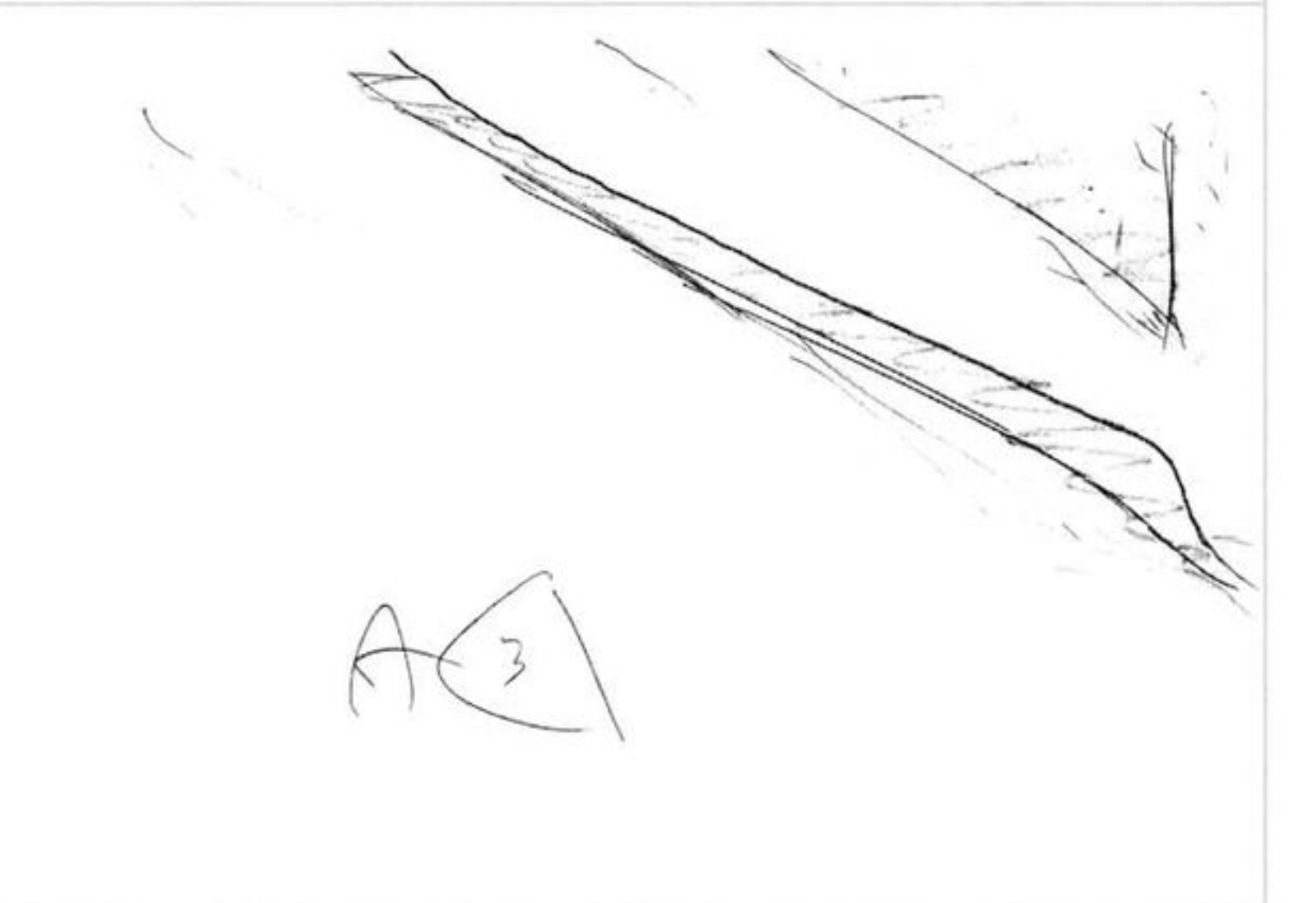
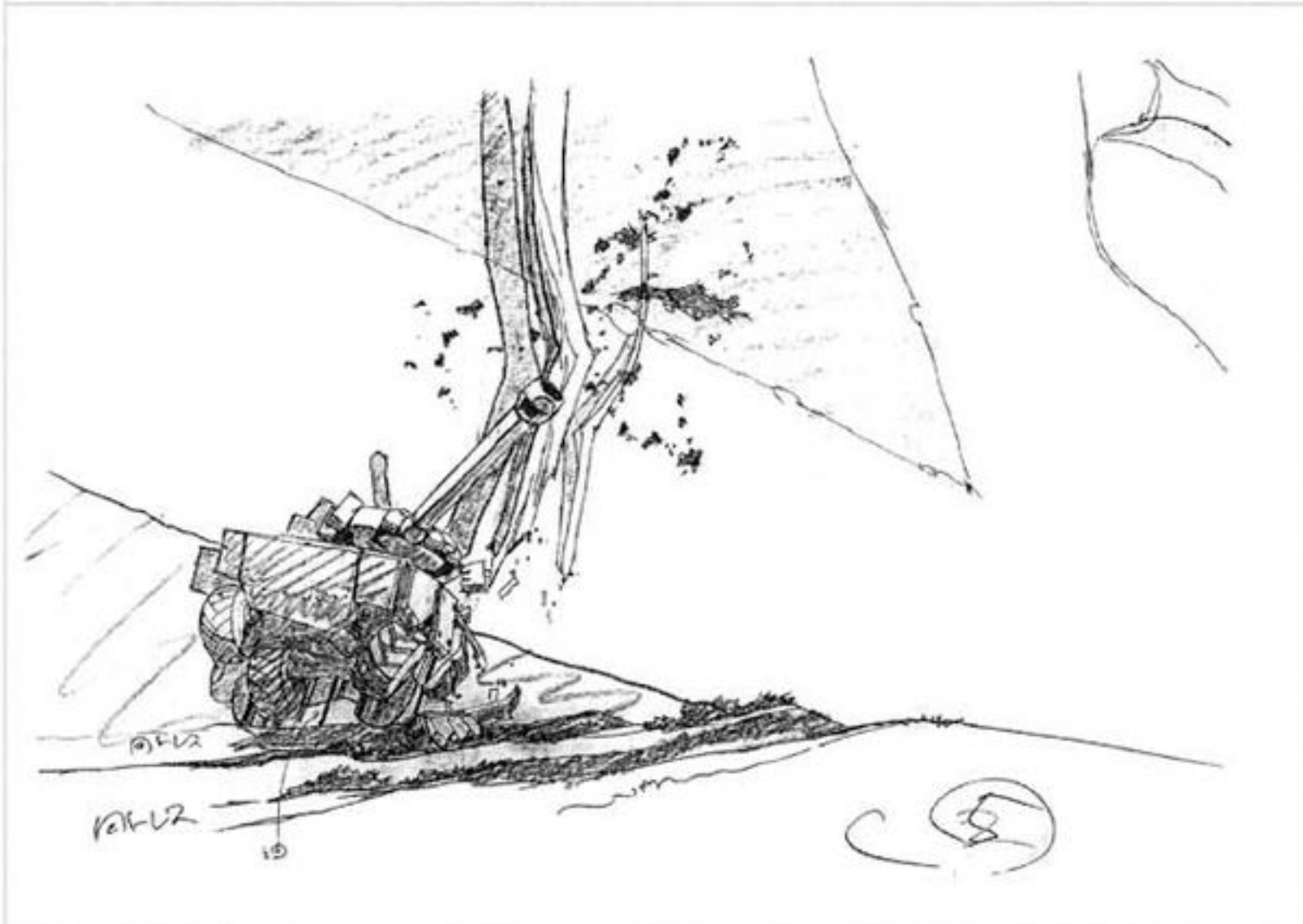
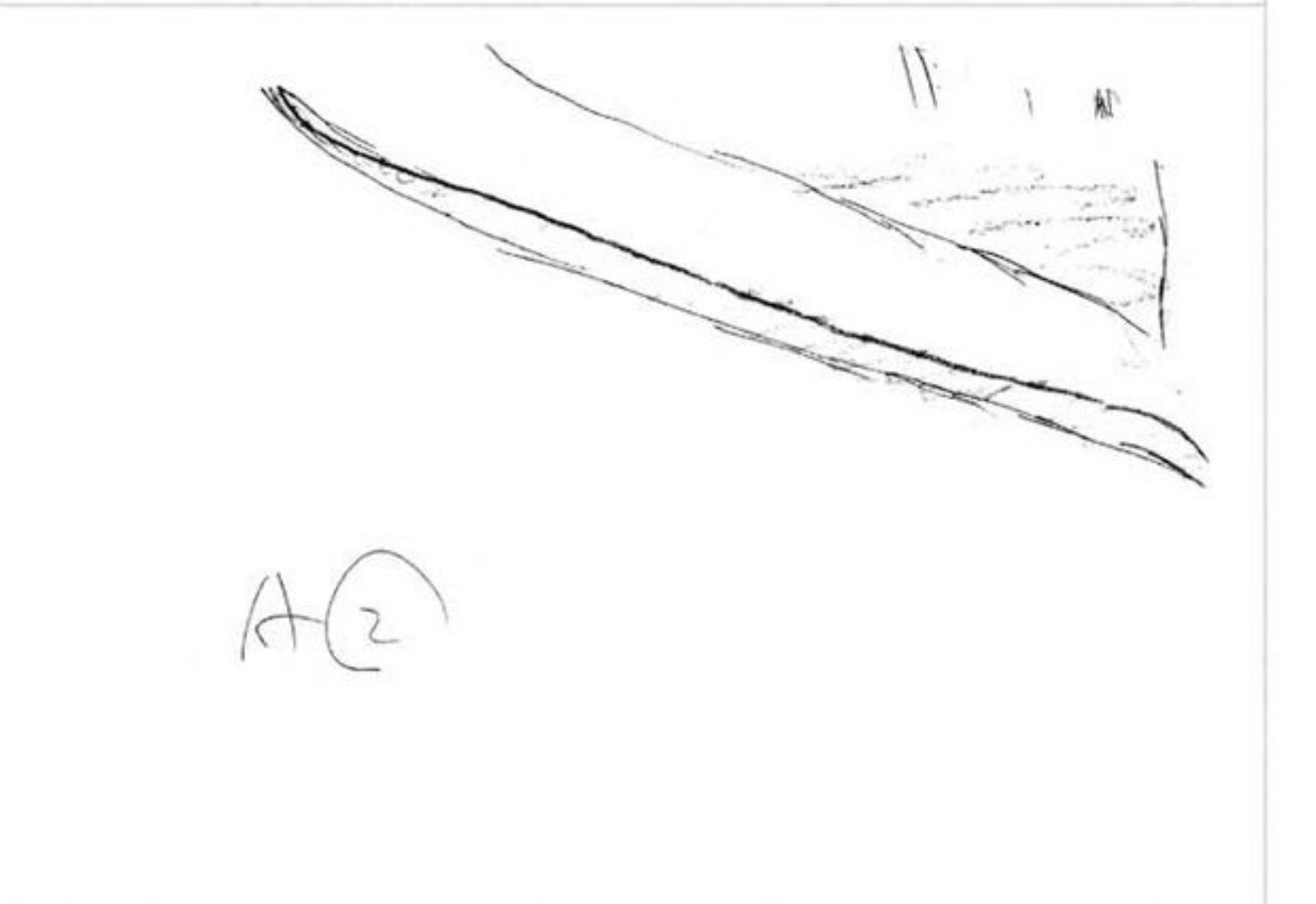
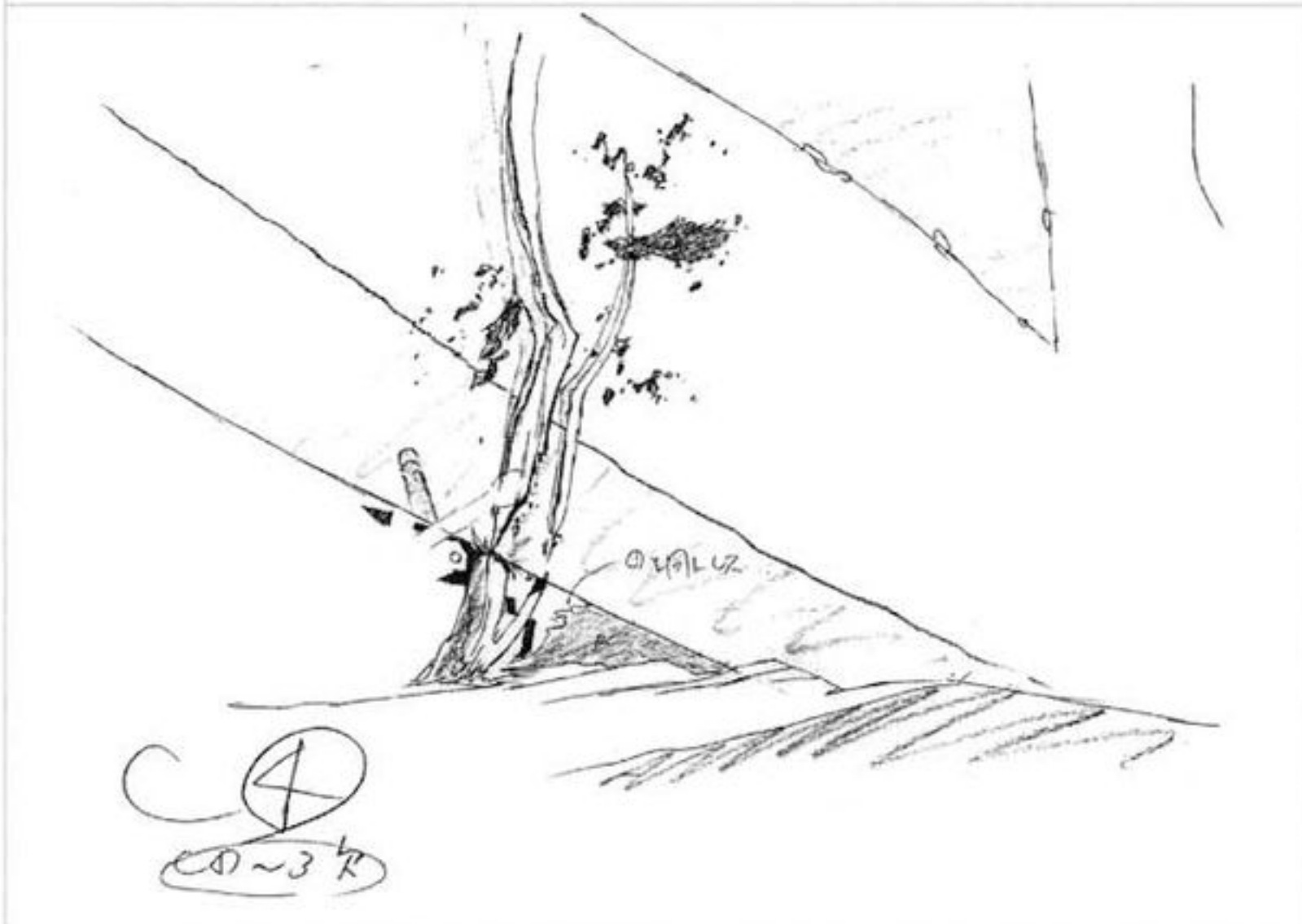
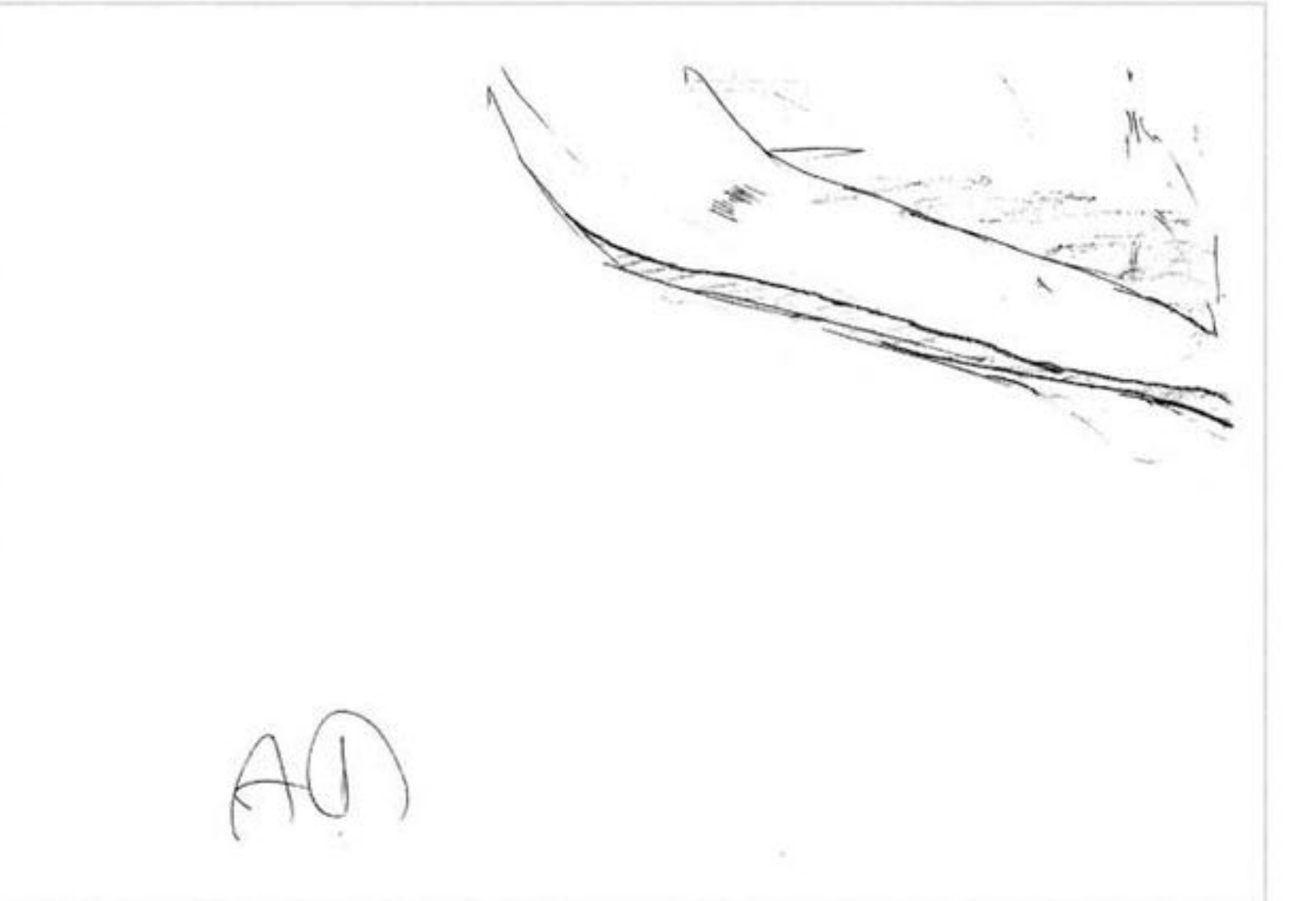
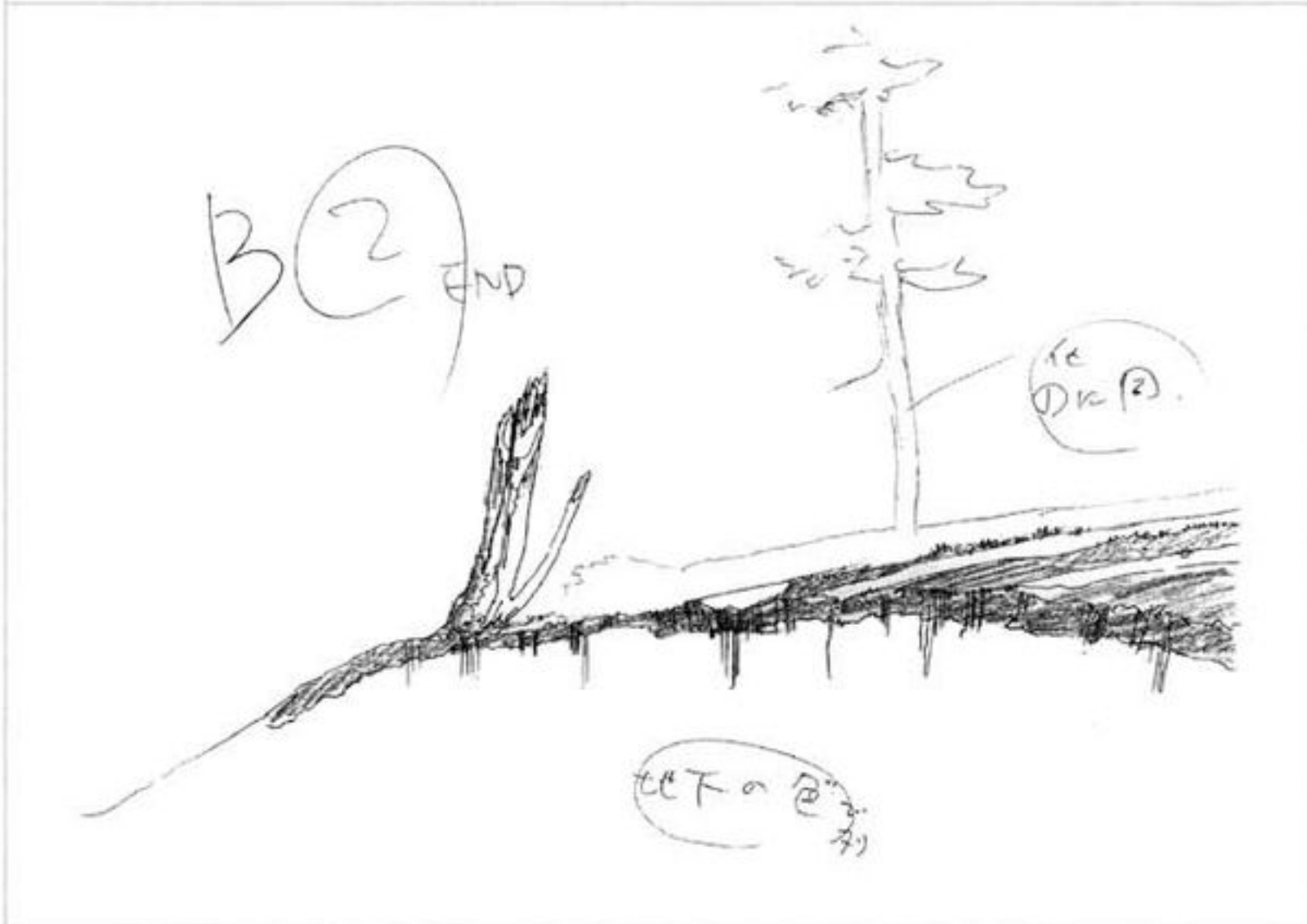



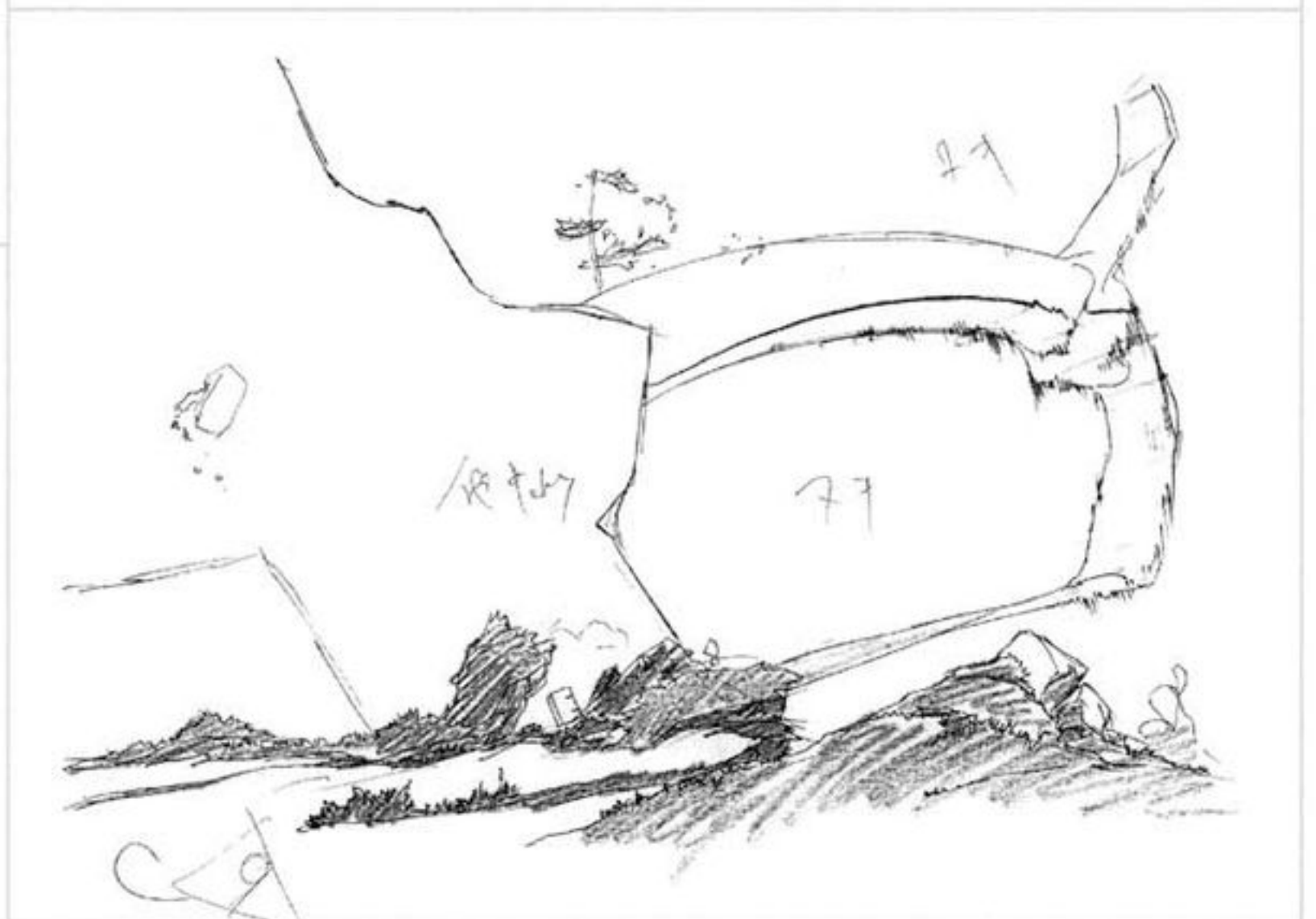
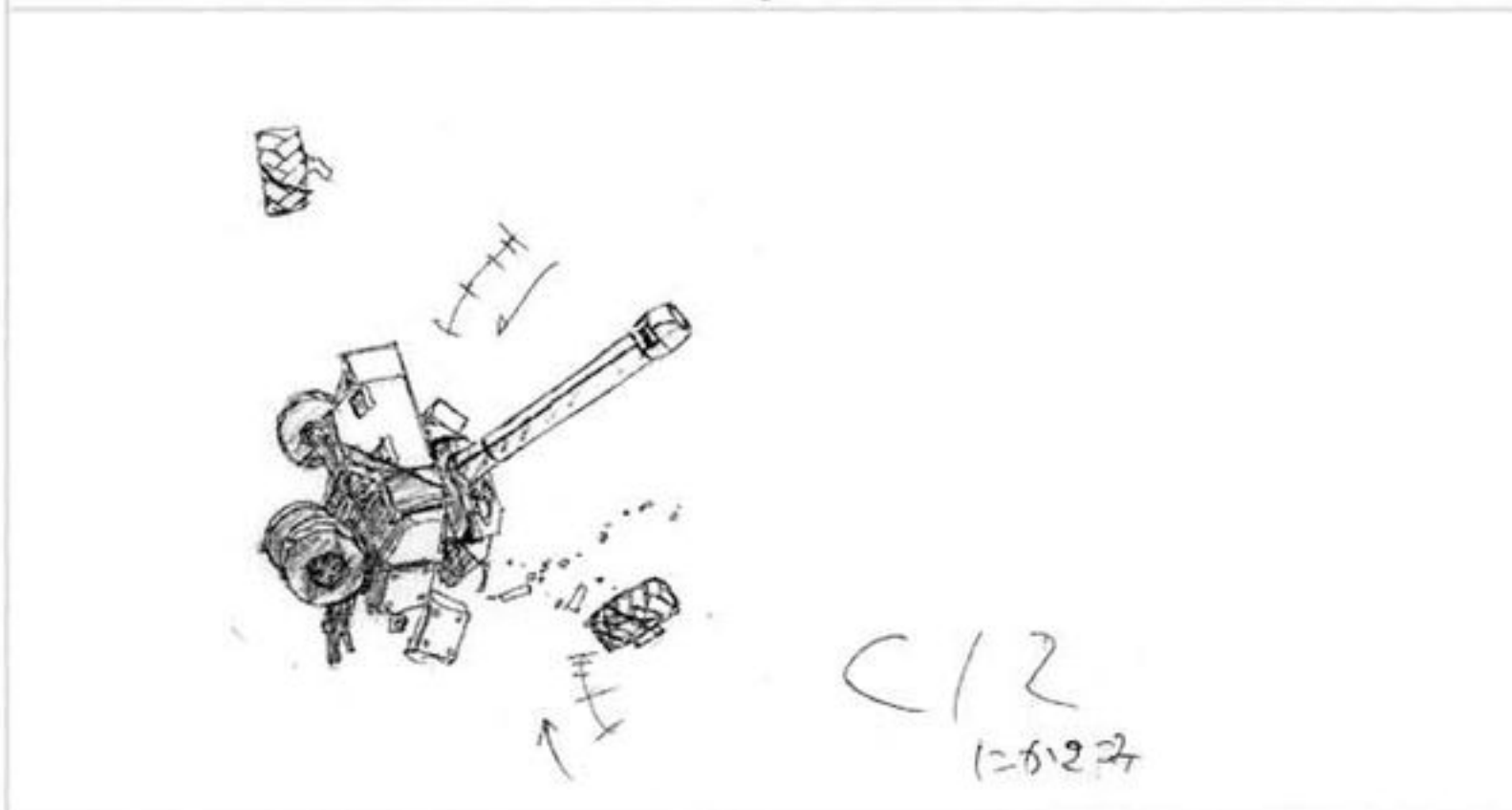
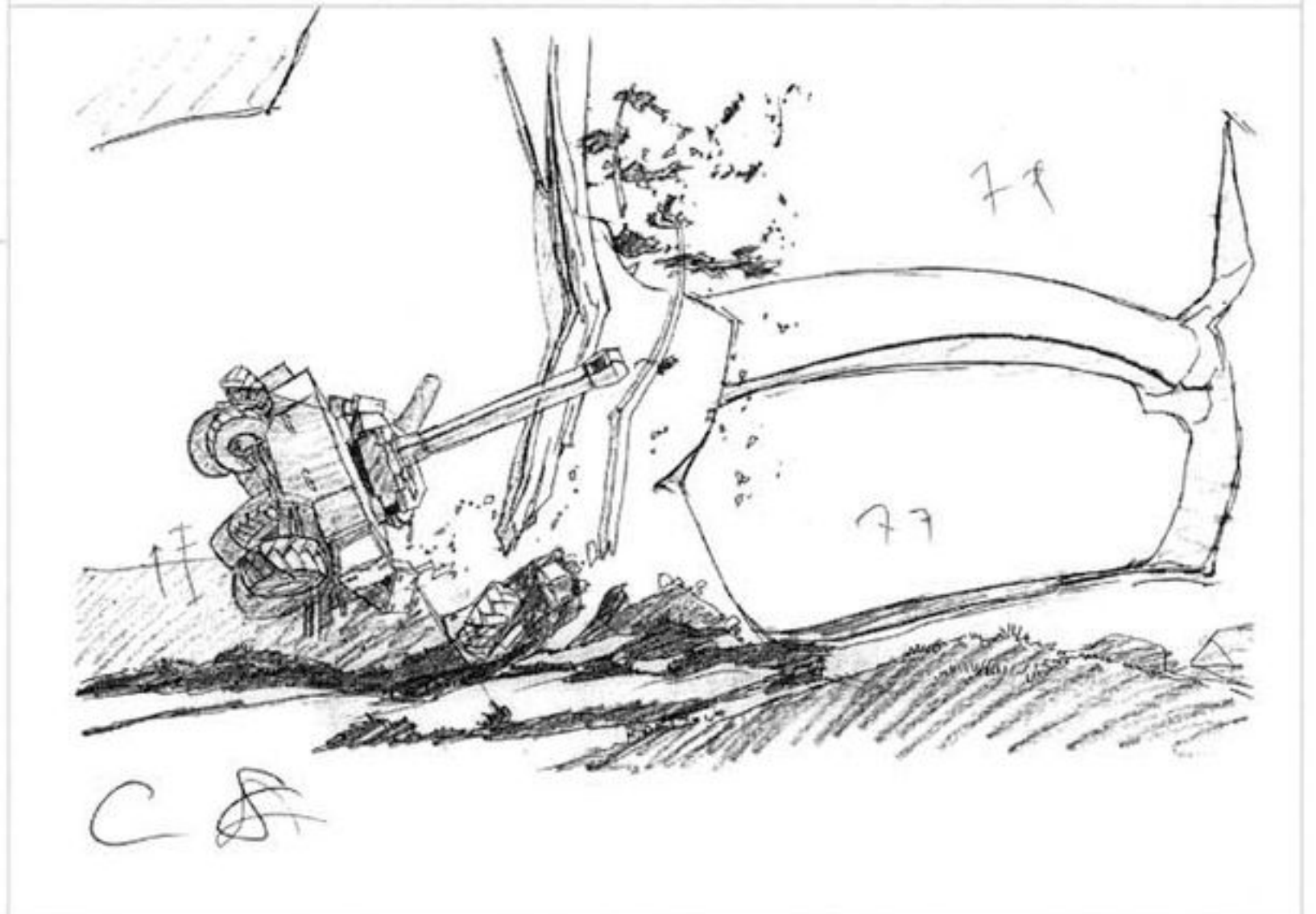
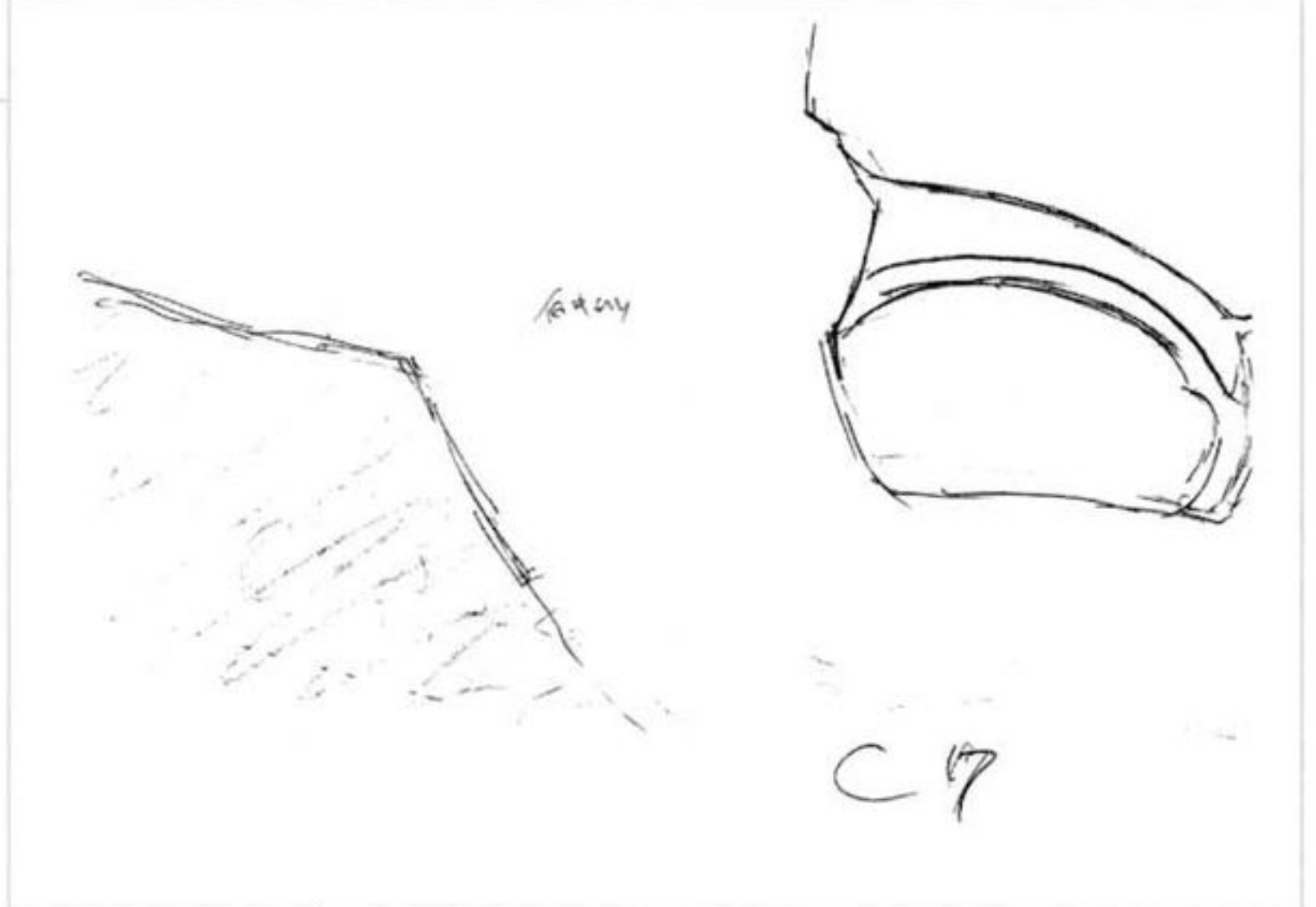
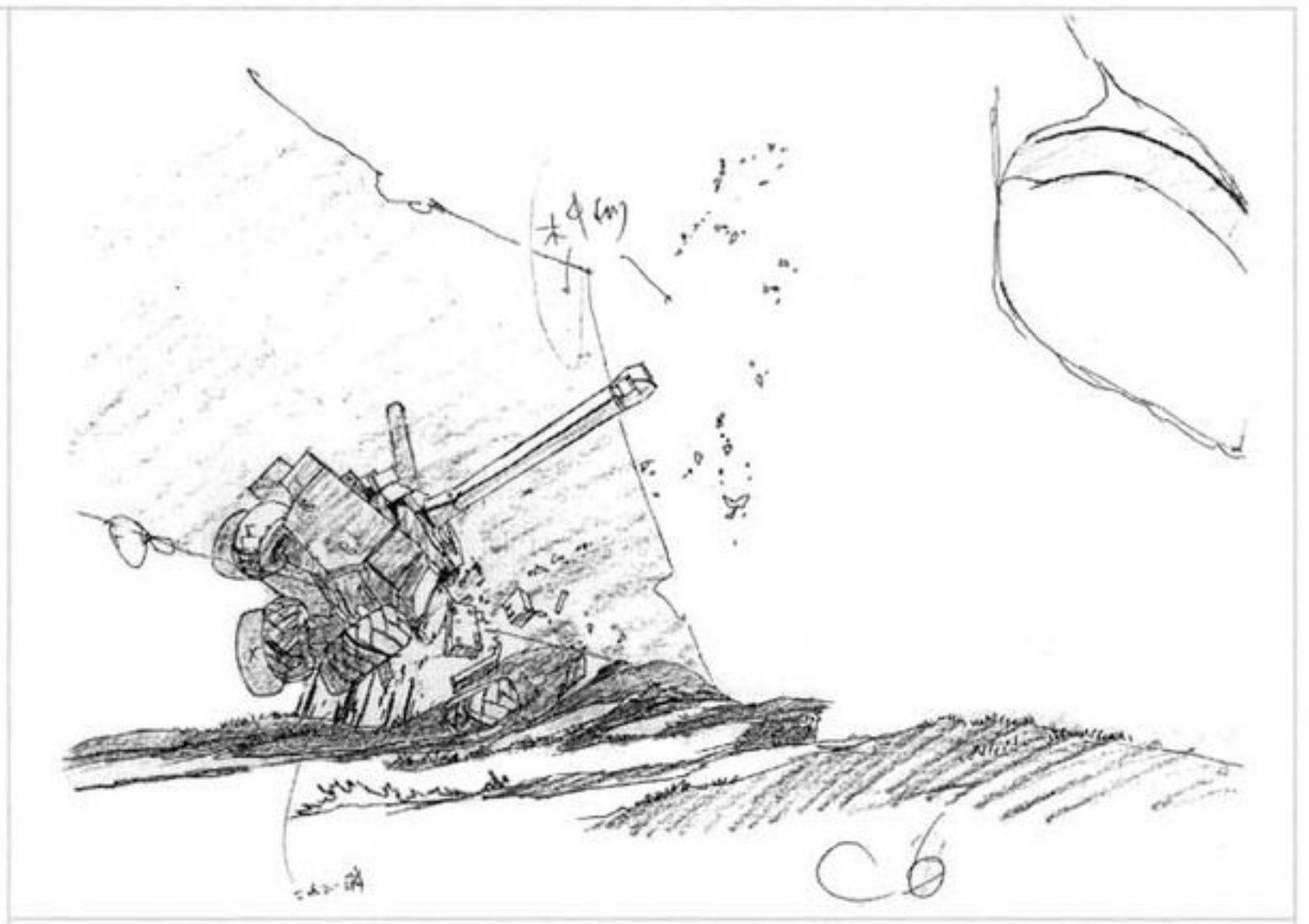



1	X	X	X	2
2				4
3				6
X	X	4		8
②	5			10
6				12
7				14
8				16
9				18
10				20
11				22
12				24
13				26
14				28
15				
16				
17				
18				
19				
20				
21				
22				
23				
24				
25				
26				
27				
28				

タイムシート

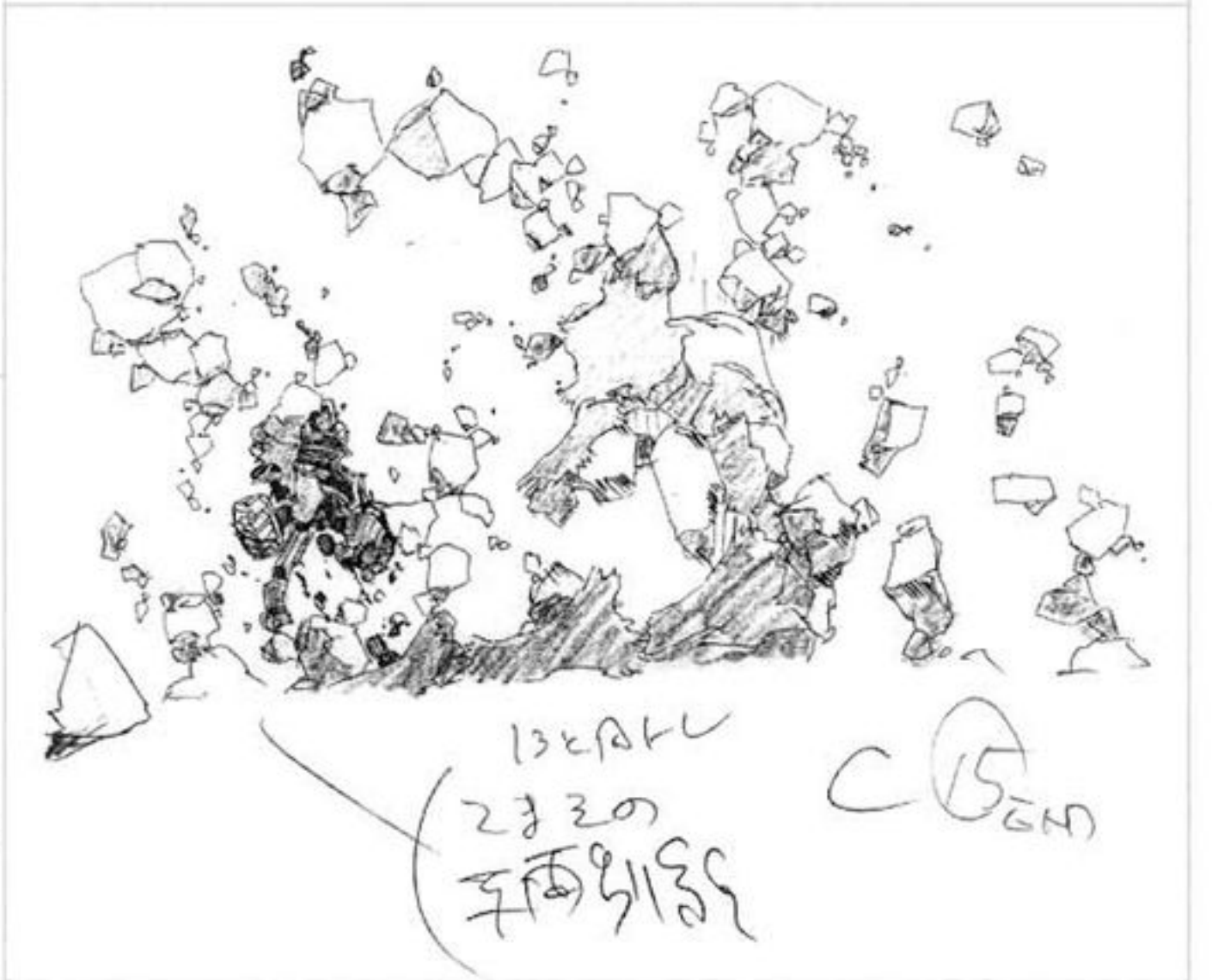
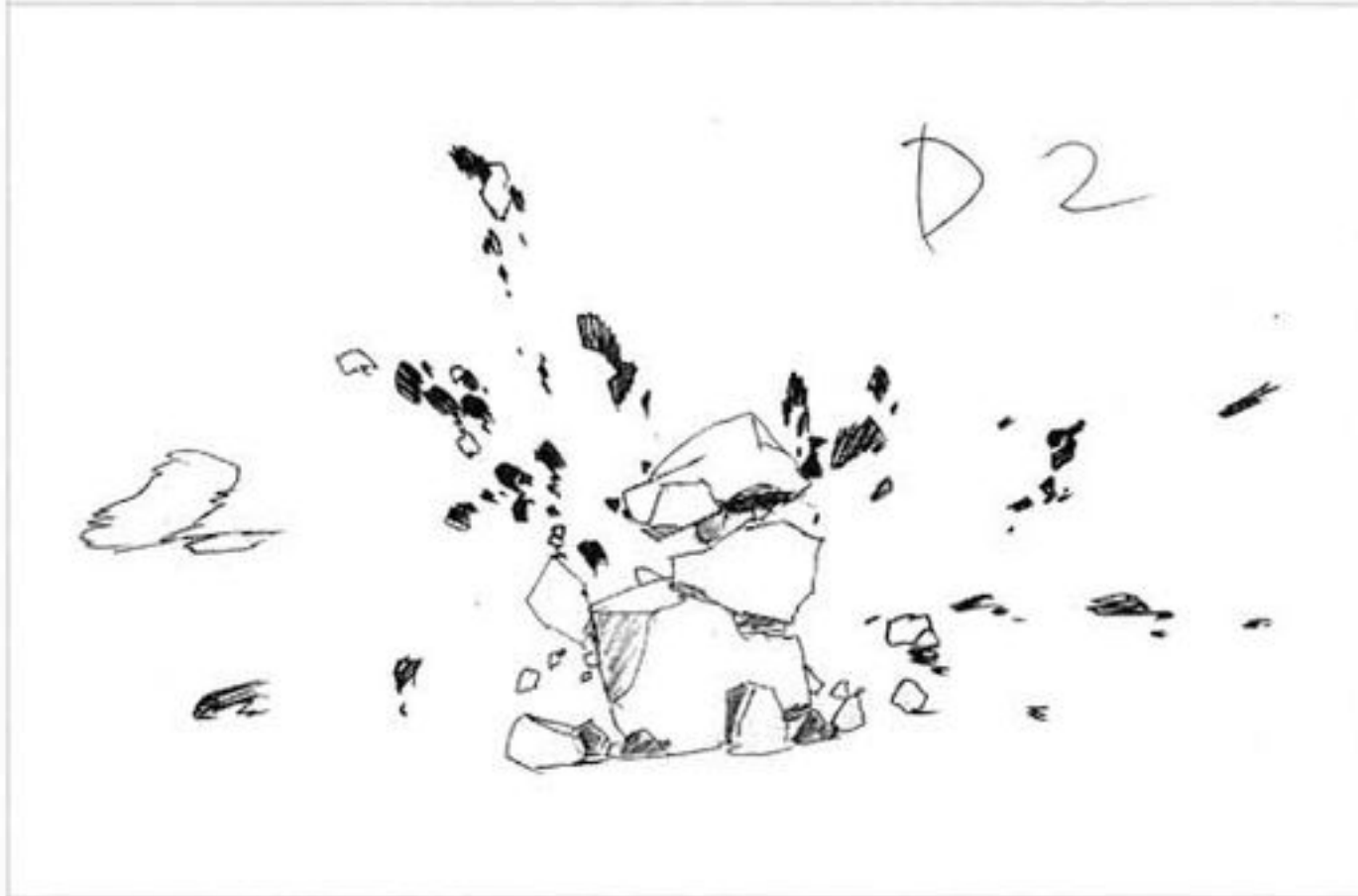
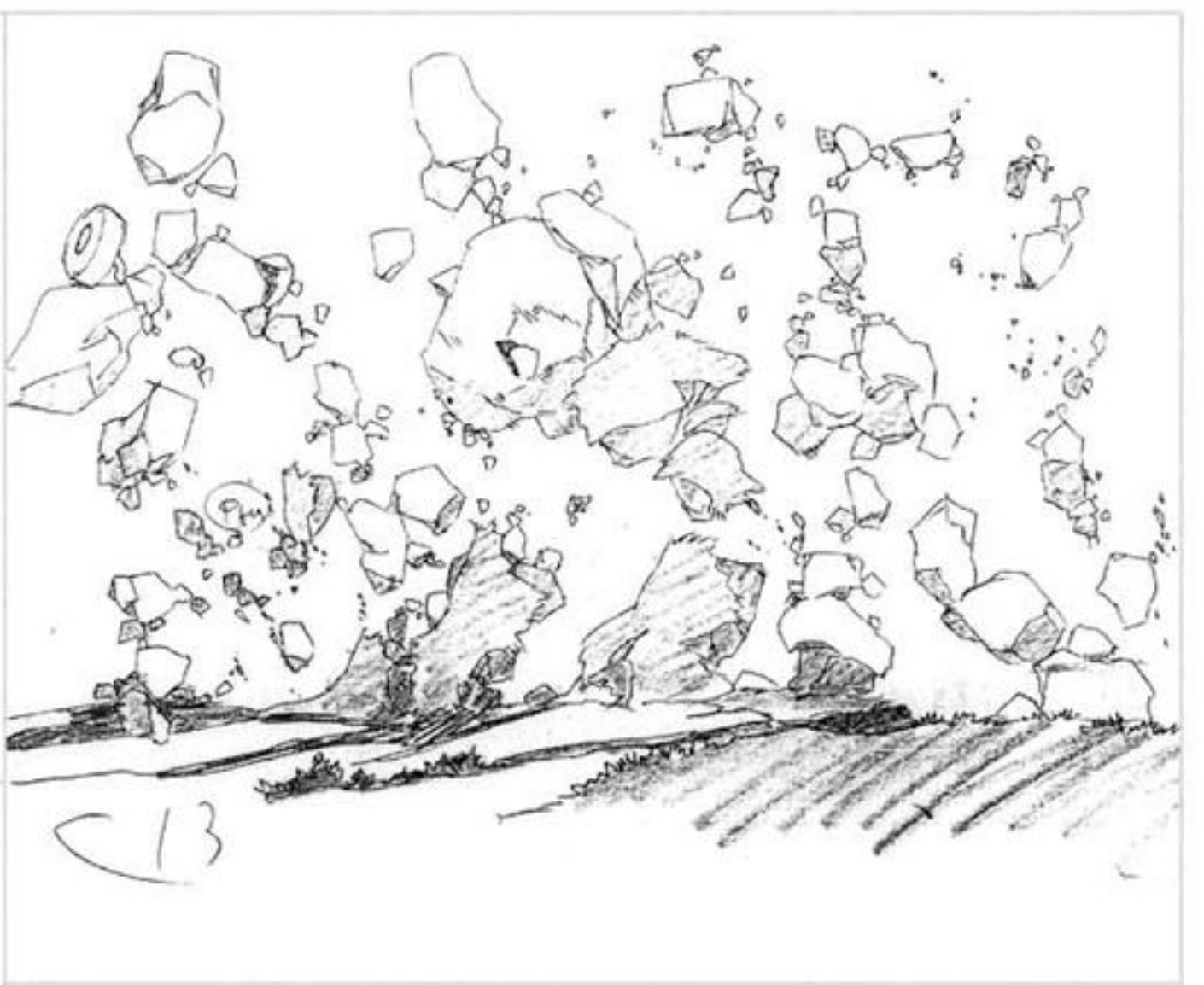



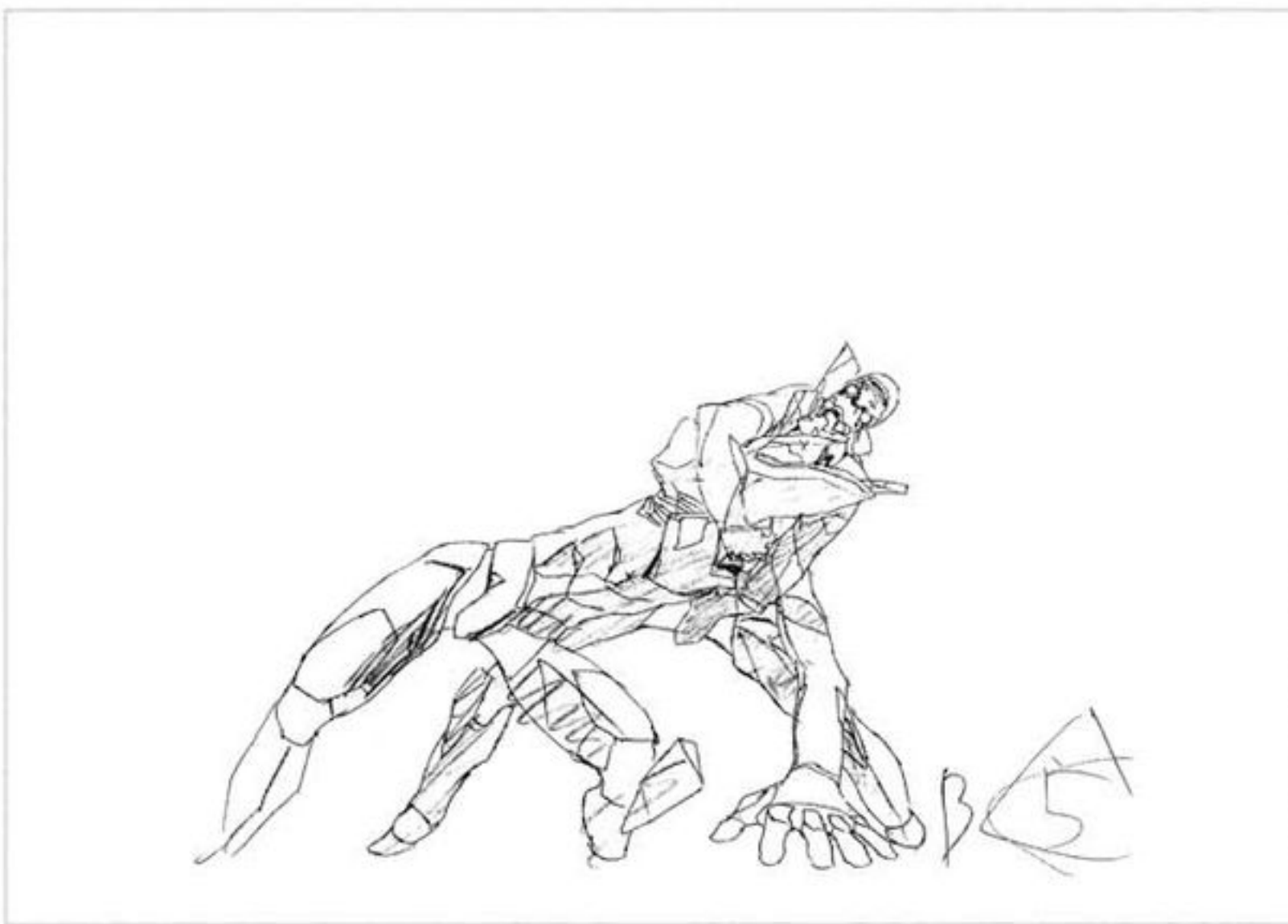

#25-C446レイアウト

#25-C446

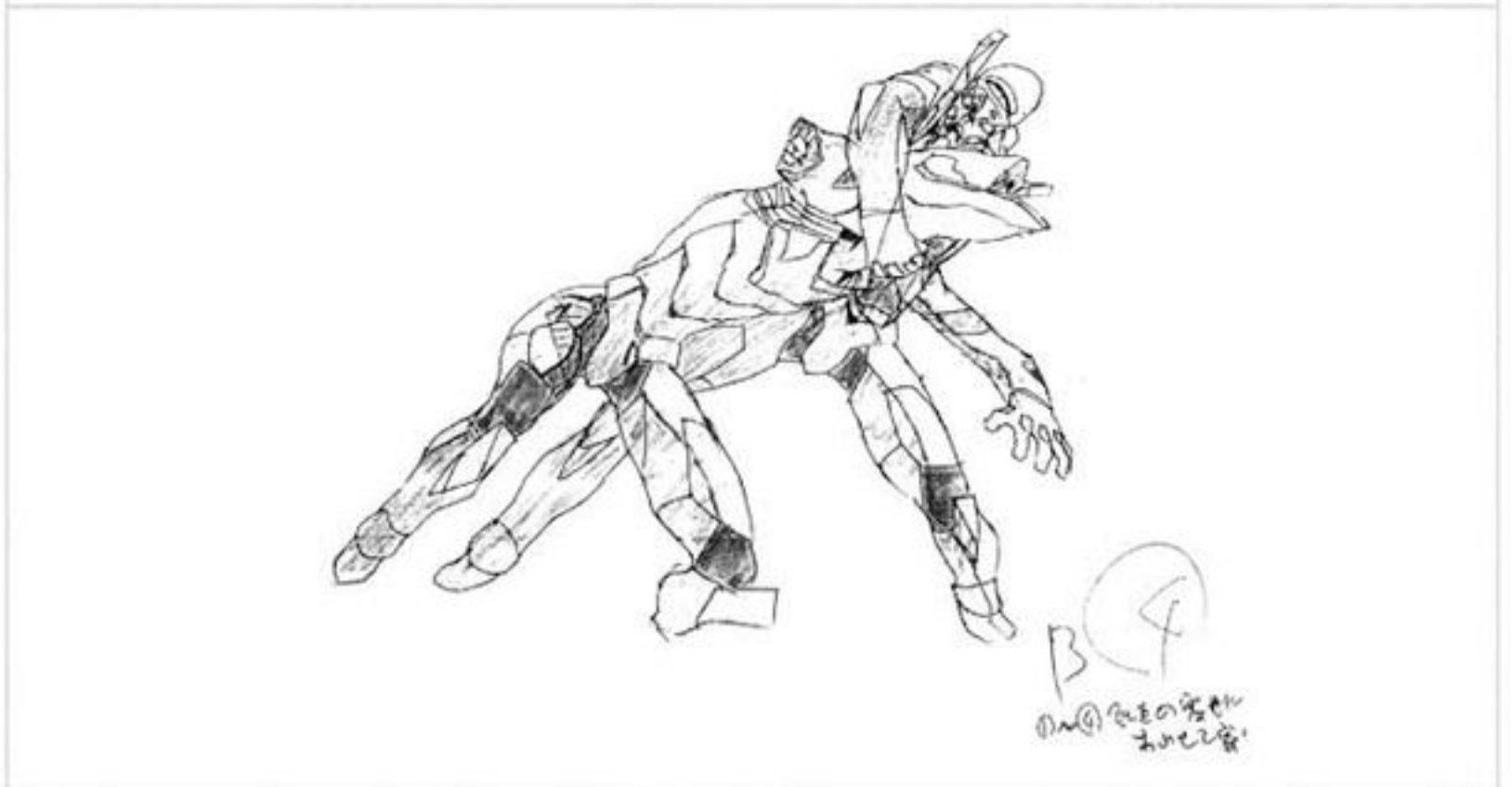
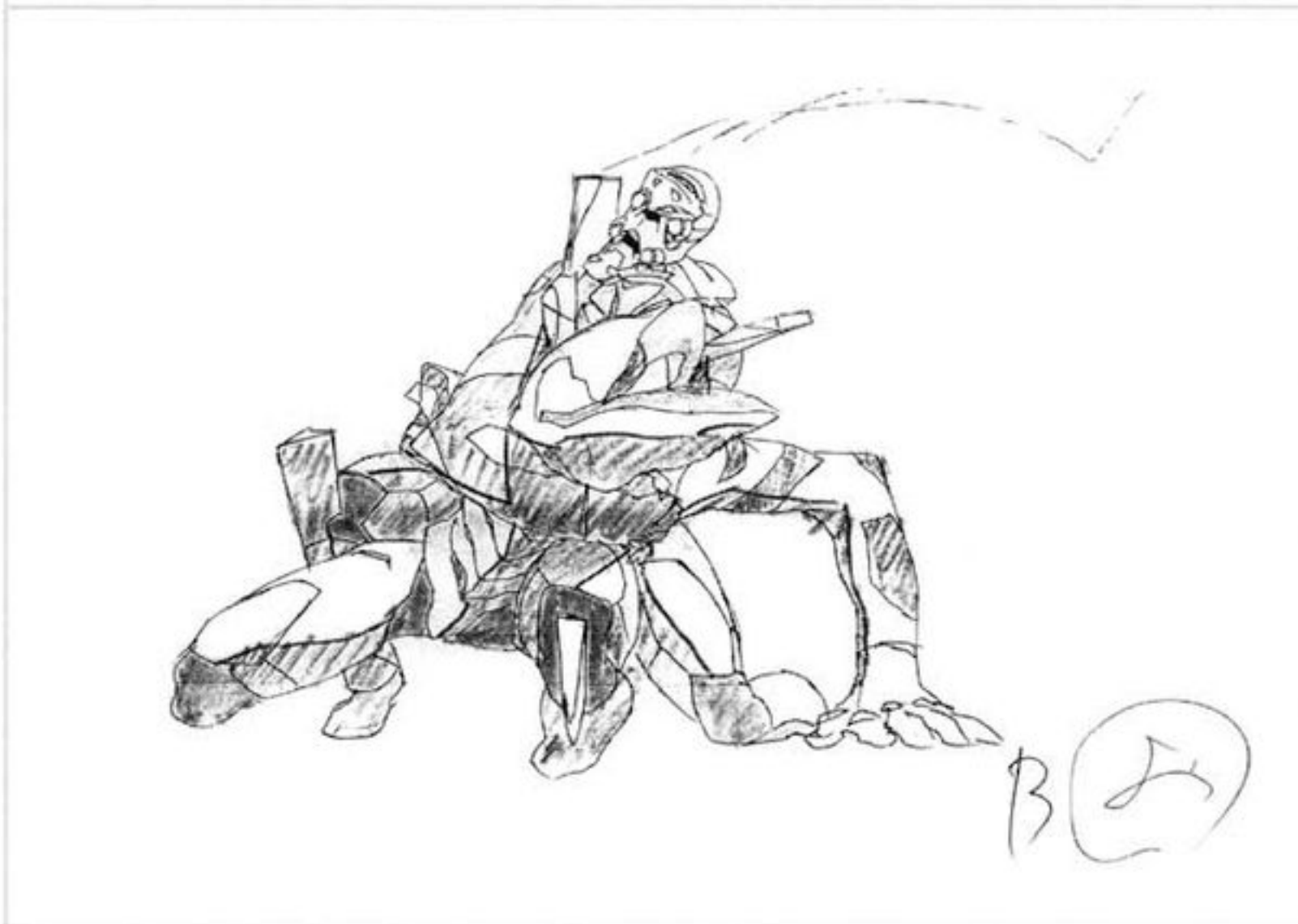
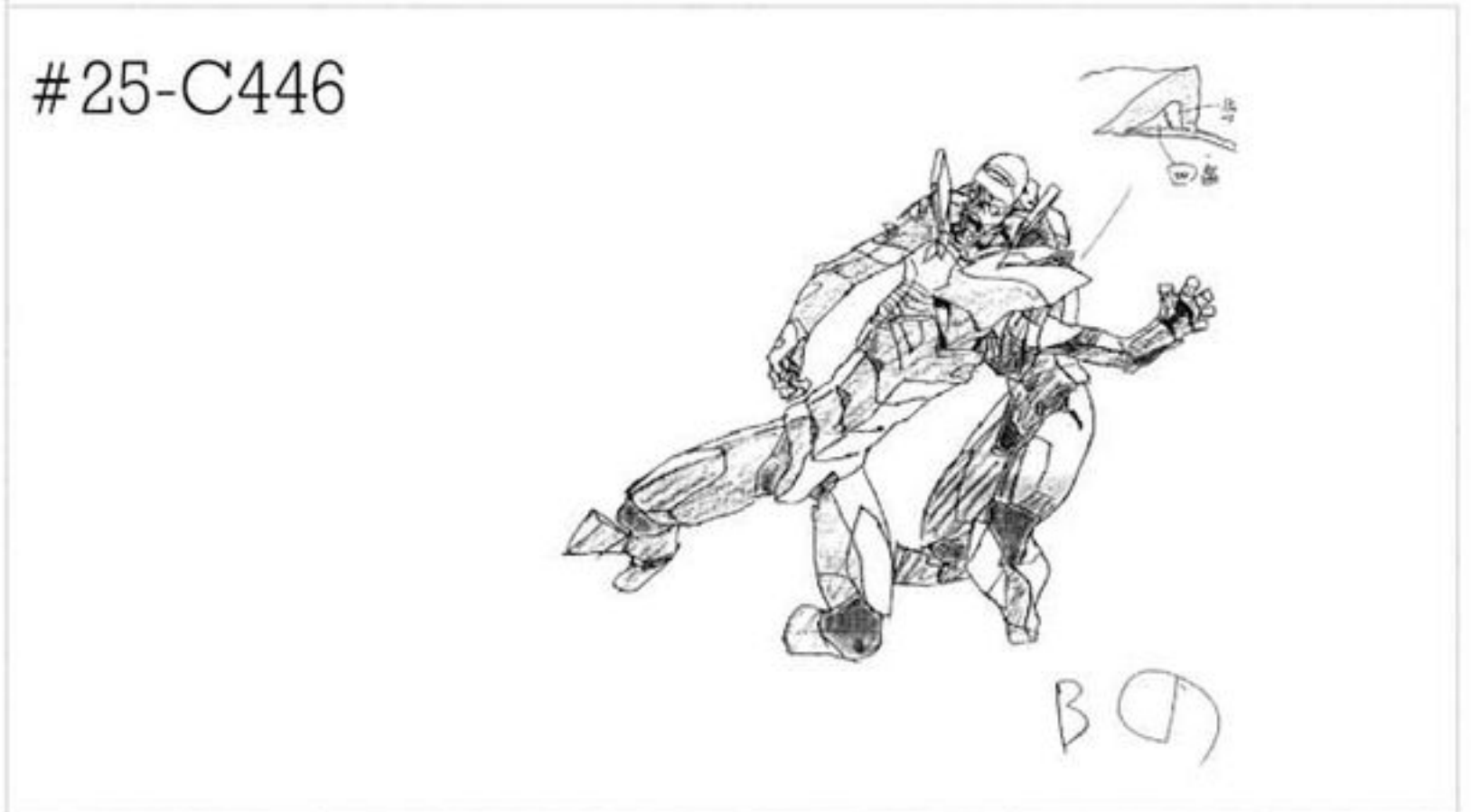





B (13)

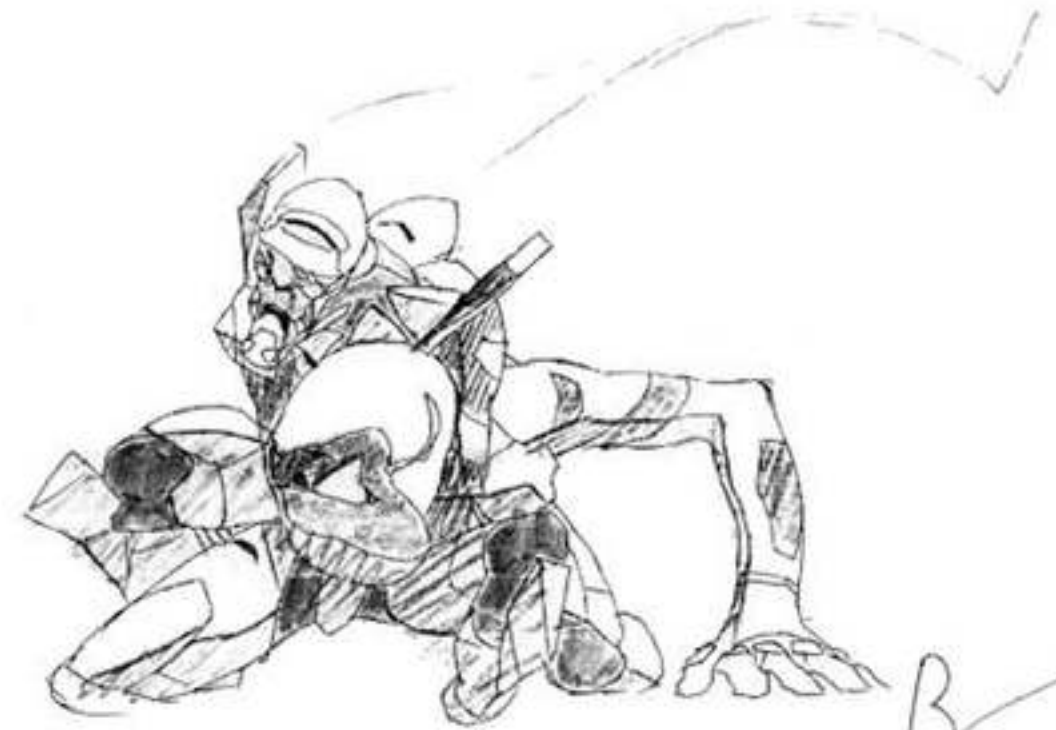

B (9)



B (14)

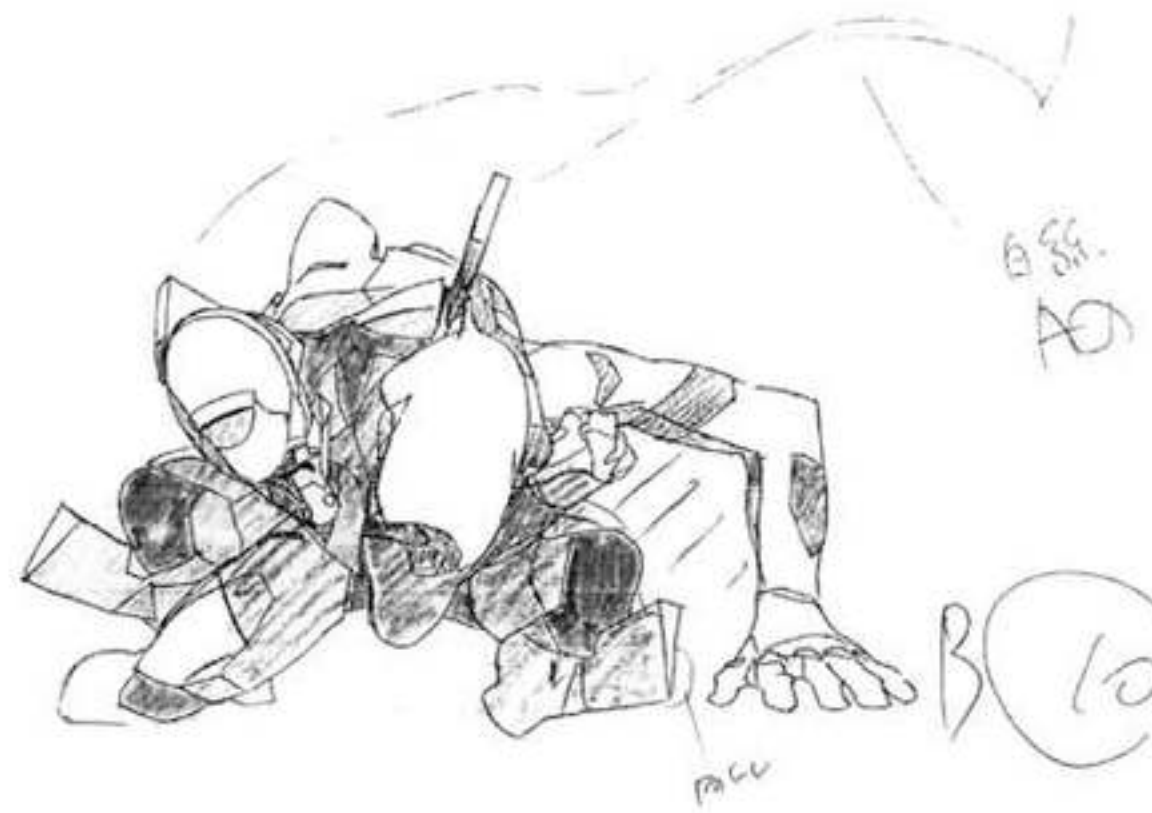

B (10)



B (15)



B (11)



I ↓

B (16)



B (12)



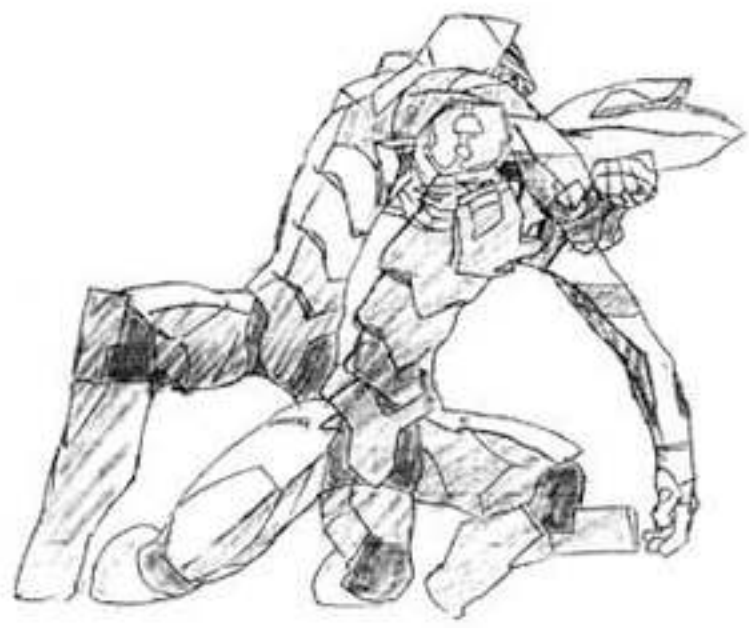

B (21)



B (17)

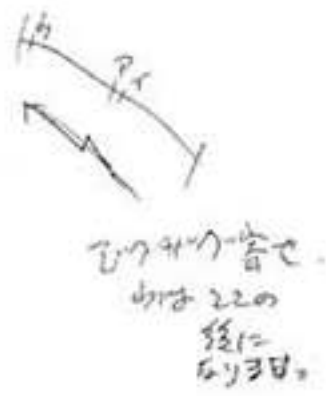
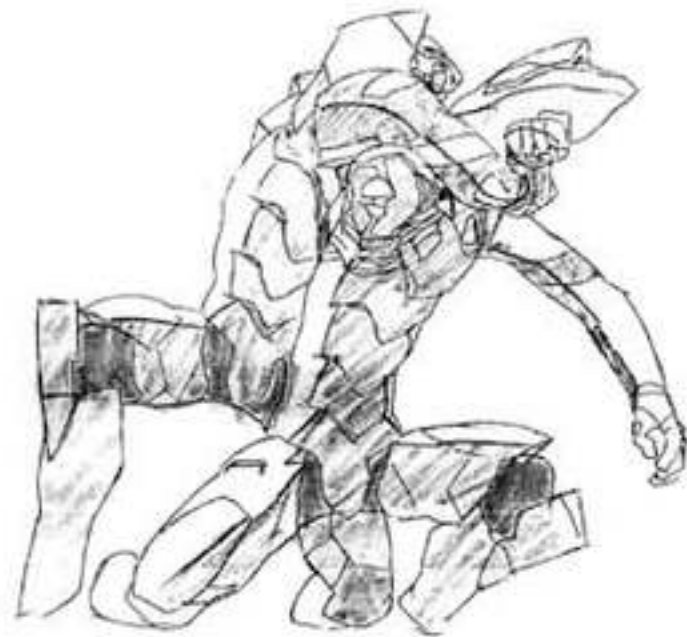

この部分で  
少し下の  
線に  
引く。

B (22)



B (18)



各部分  
B (17) (21) (22) の  
中あたり  
ありせん  
@ 6.27.2011.

B (23)



B (19)



B (24)



B (20)











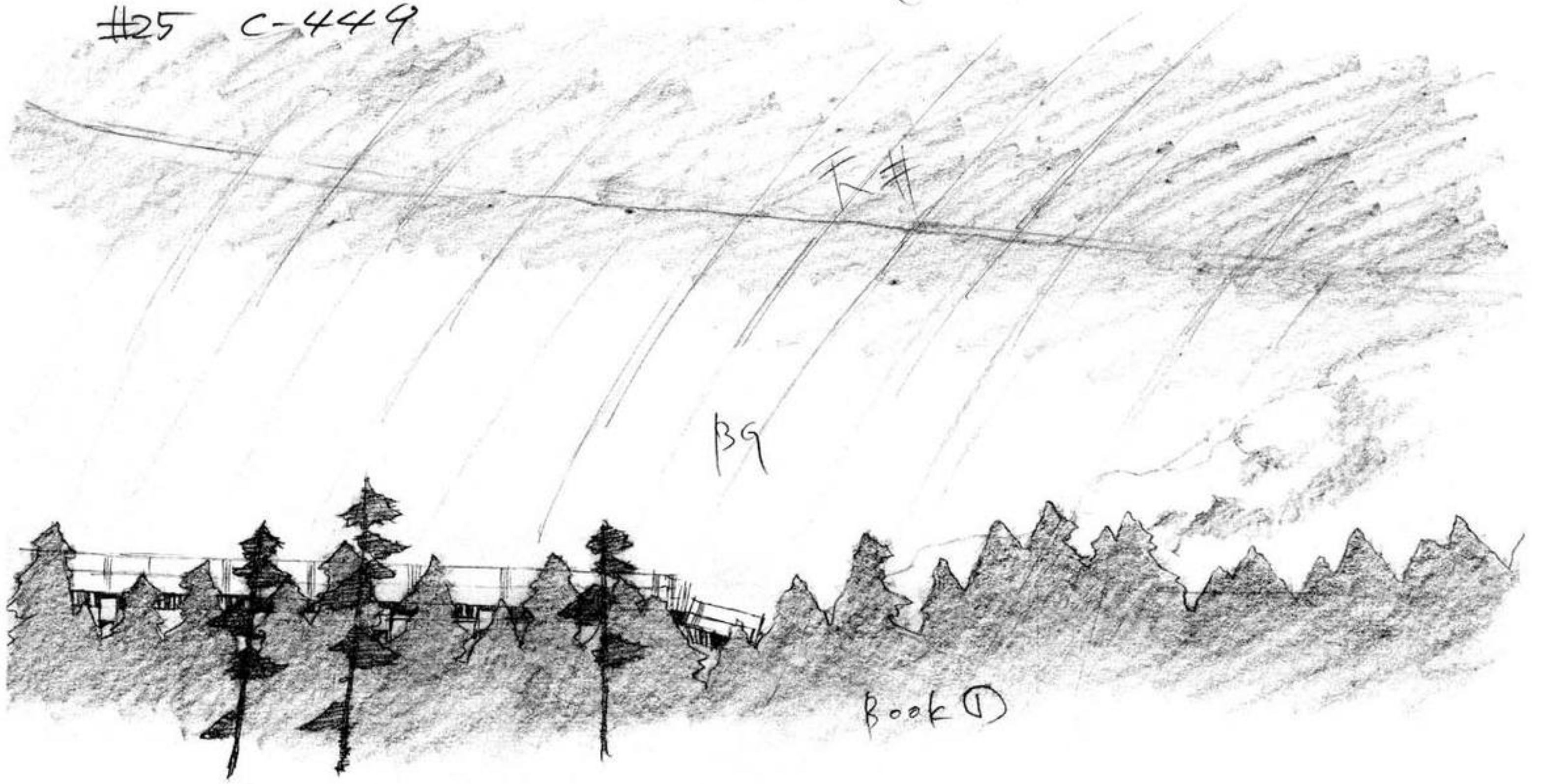

(2+12)

#25 C-449



#25-C449レイアウト

 <p>B6 レポル</p>	 <p>B3</p>	<p>B01</p>  <p>#25-C449</p>
 <p>B7</p>	 <p>B5</p>	 <p>B2</p>



BG. Book 3のレイアウト

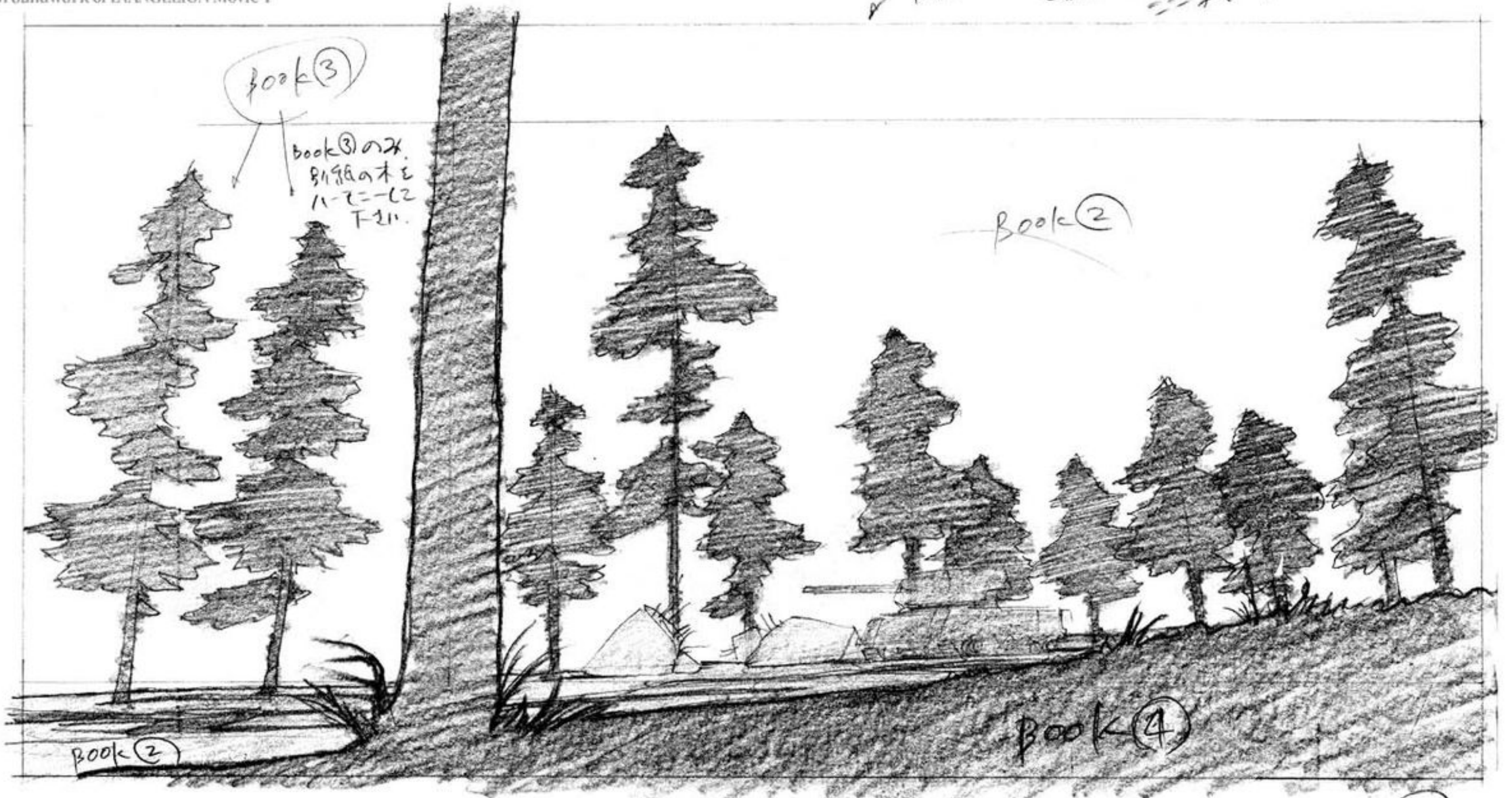

#25-C449レイアウト(BOOK)

<p>Book (3) Book (3)のみ B19のオエ ハニニニ F211.</p> <p>Book (2)</p> <p>B 12</p>	<p>B 10 か224 か2107P</p>	<p>B 8</p>
<p>B 13</p>	<p>B 11</p>	<p>B 9</p>
	<p>B 11 か224</p>	<p>以後、 手前 別紙に あ110</p> <p>B 10</p>



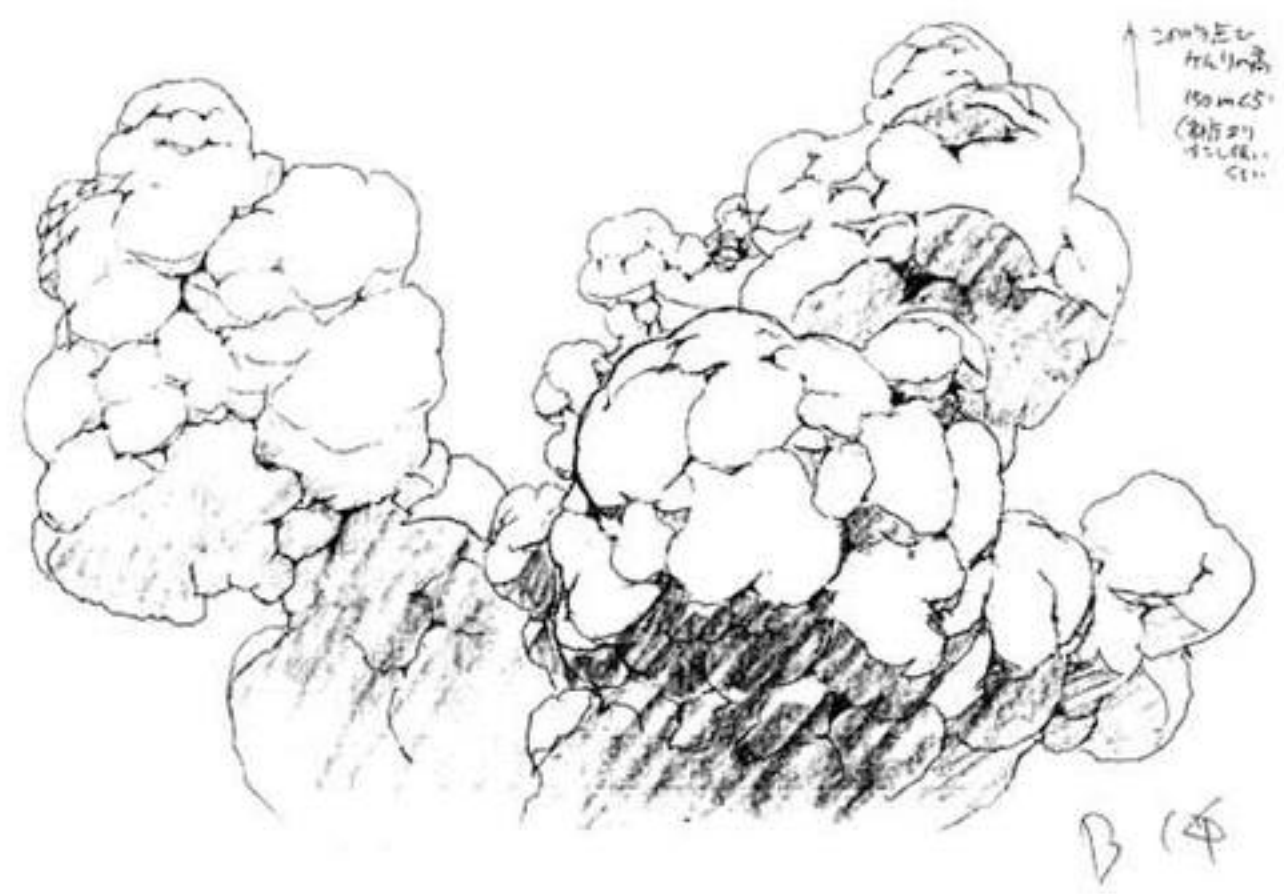
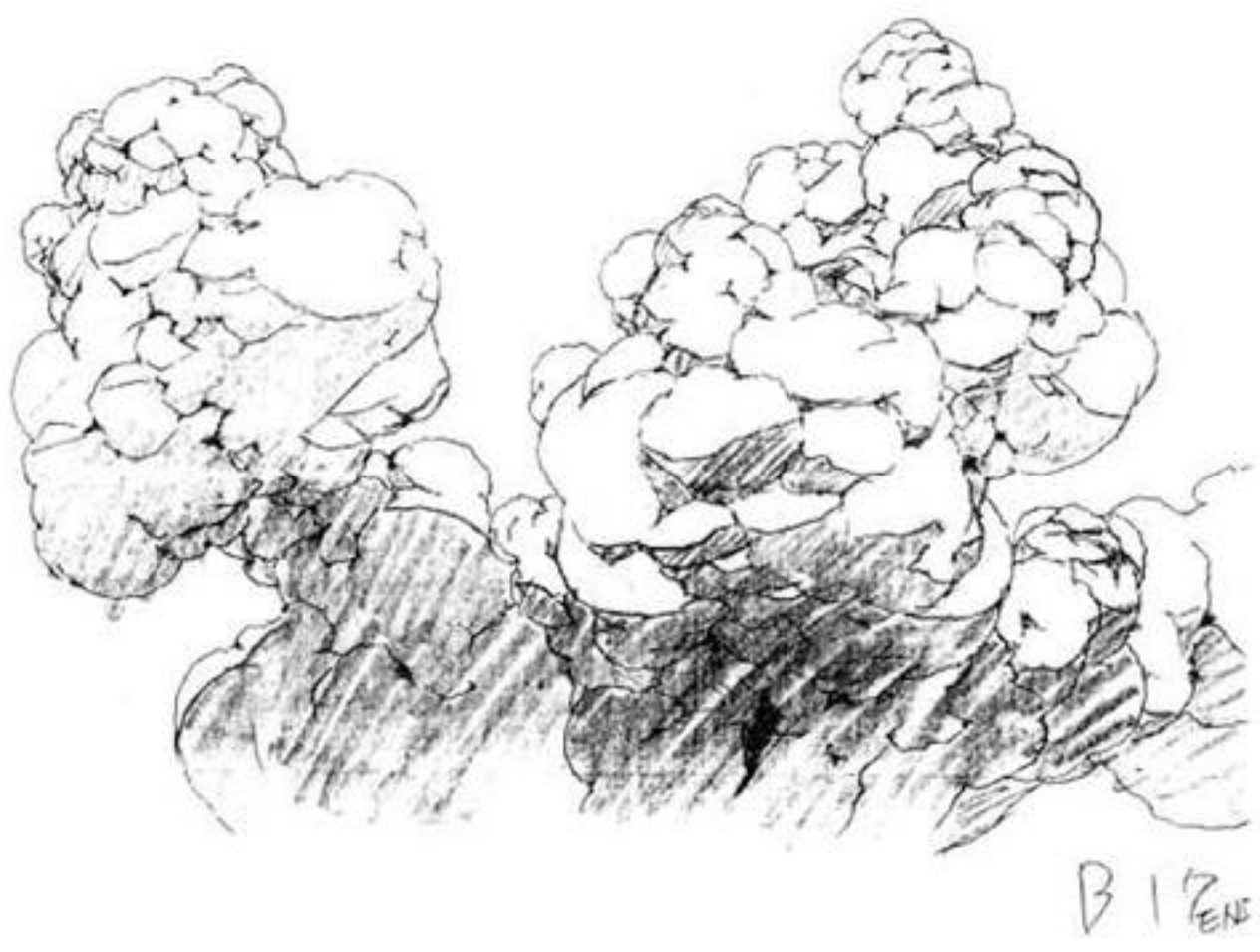
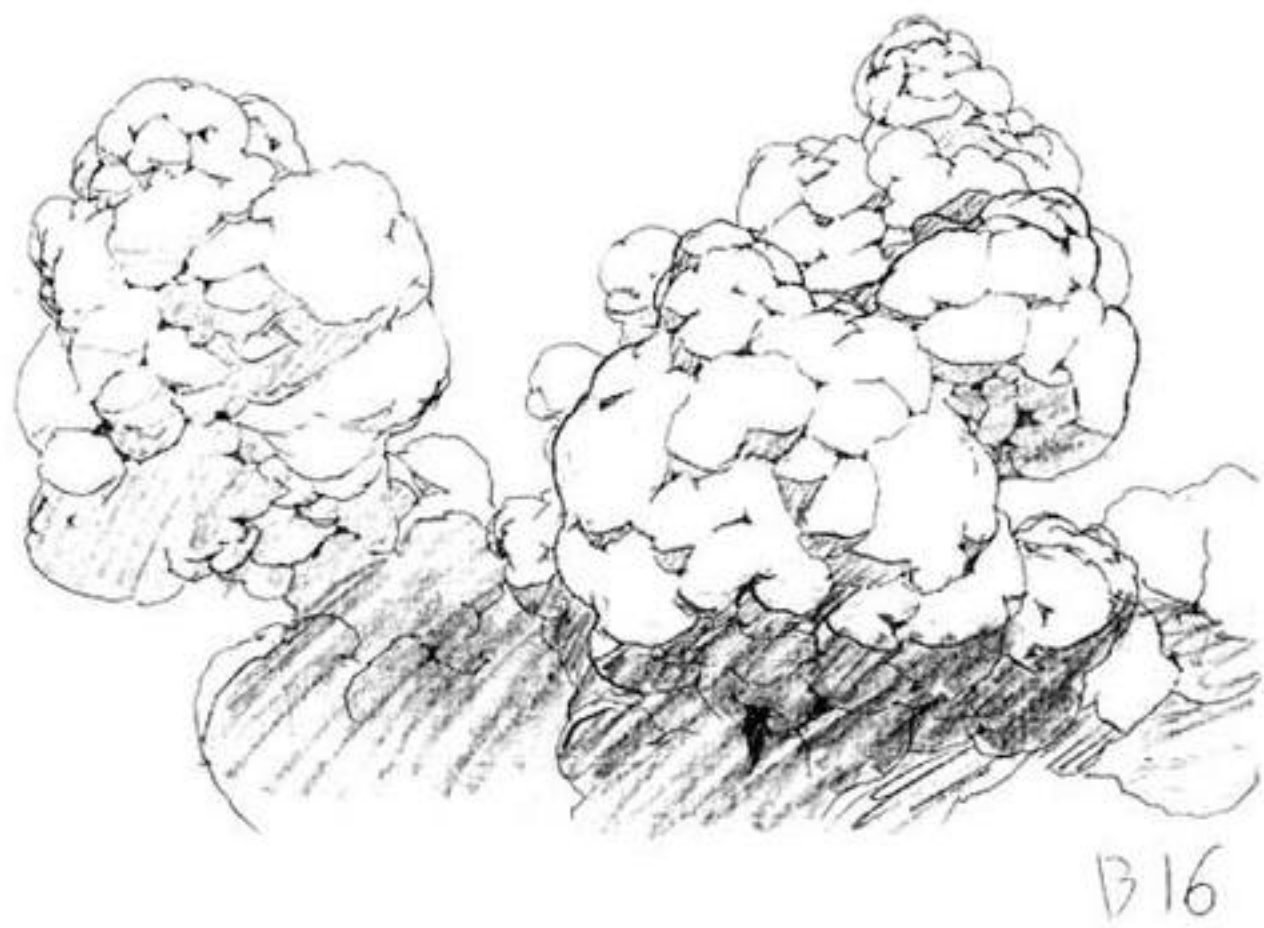
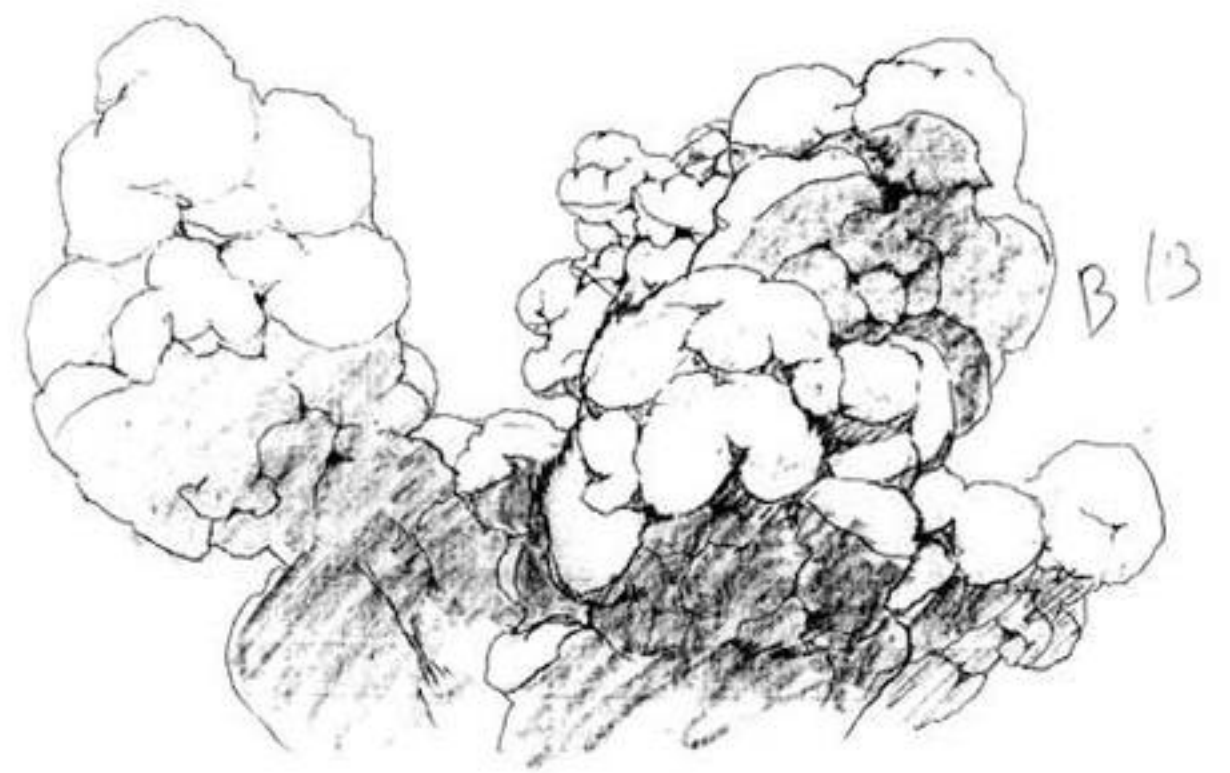
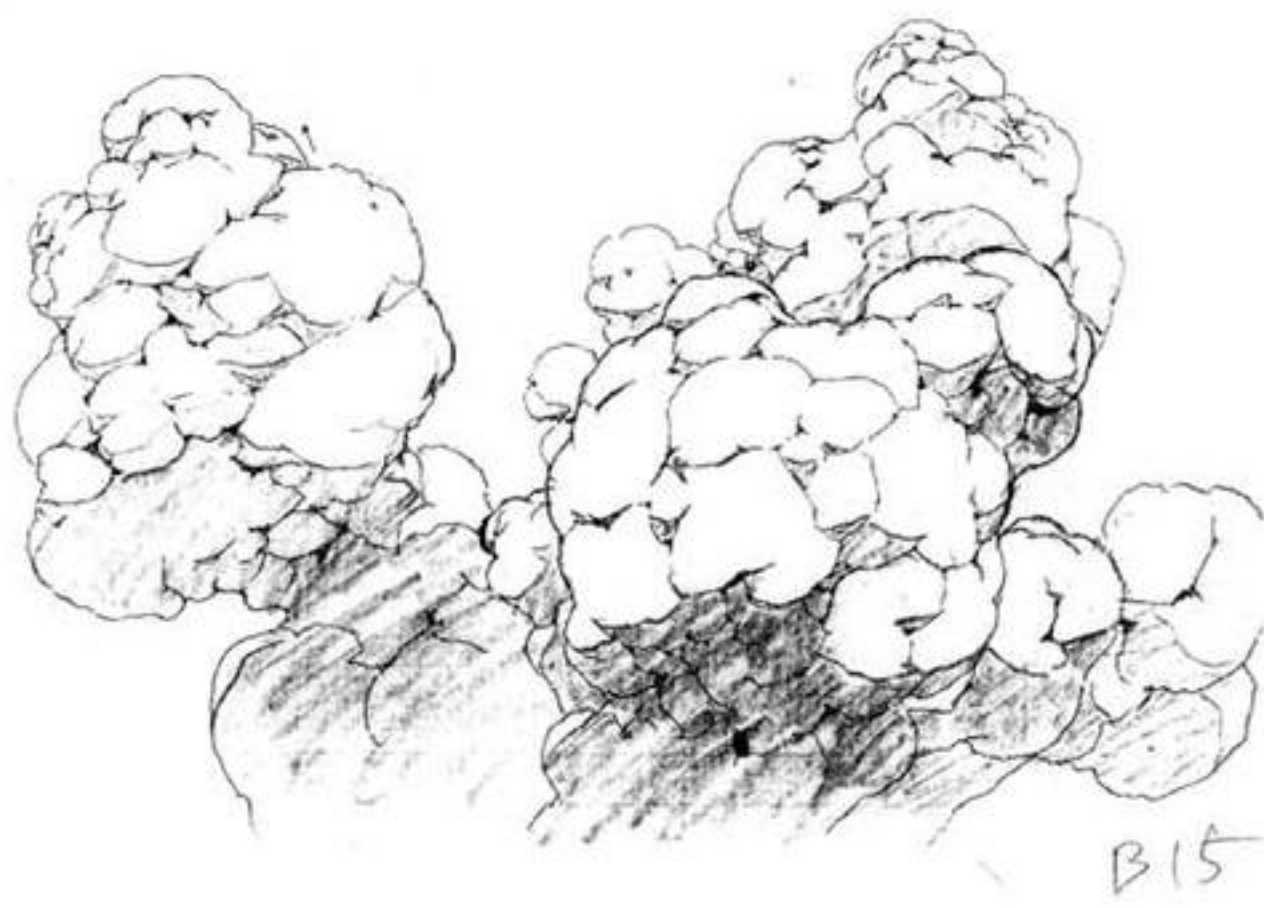

#25-C449

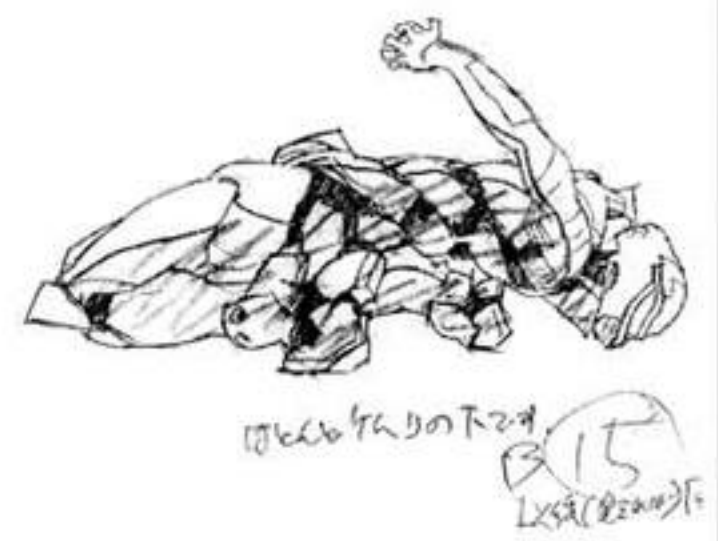



#25-C449

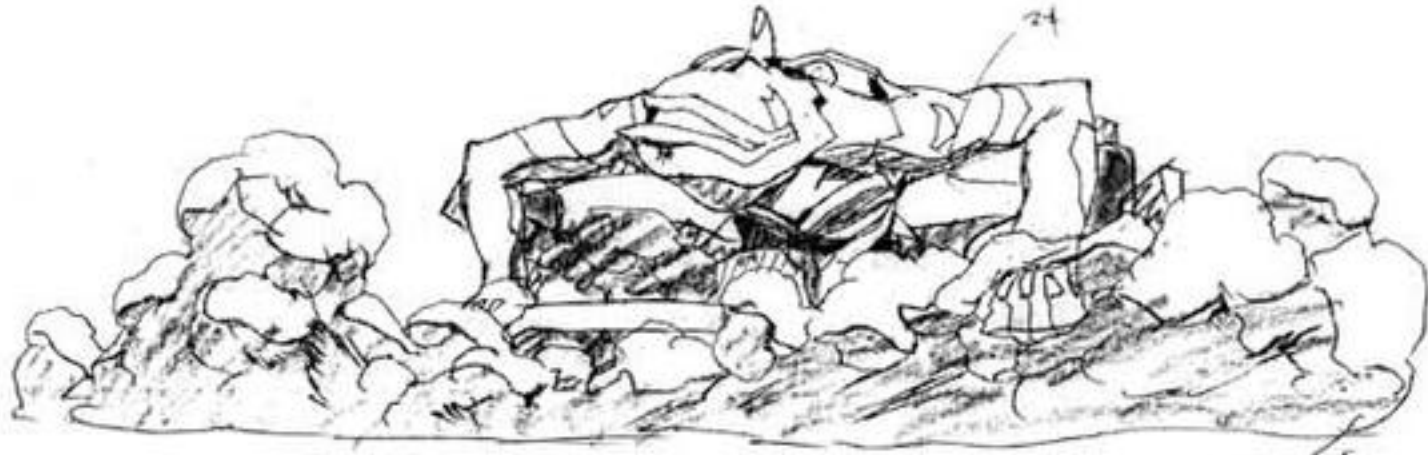
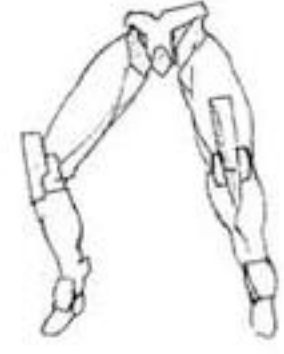

C4

C1

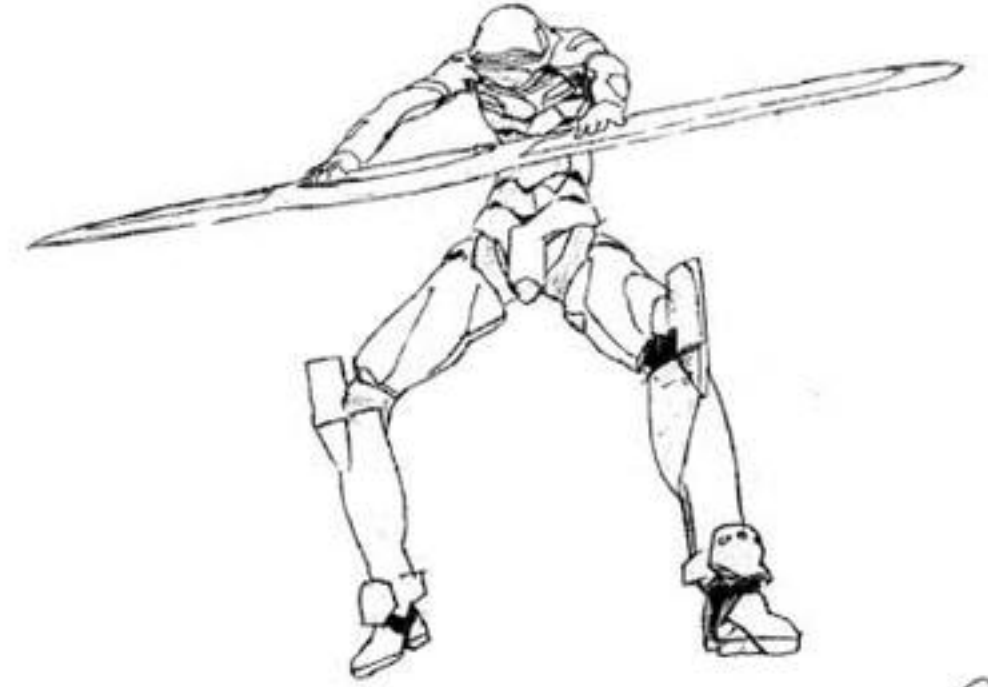

C2

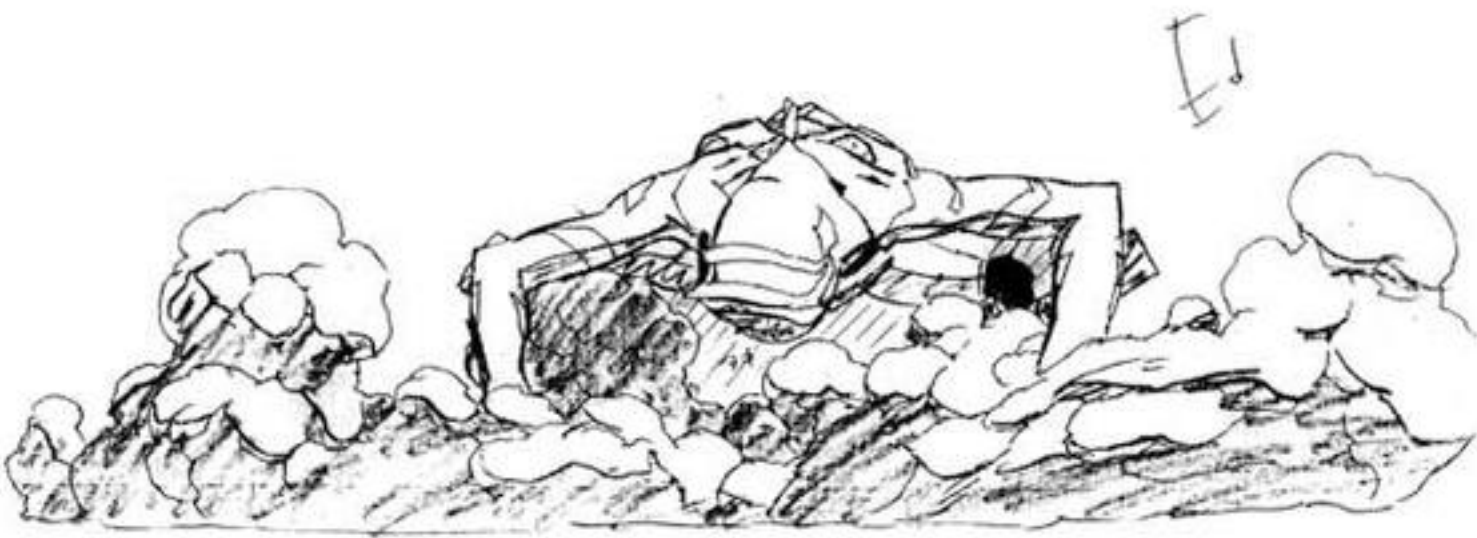

C5



C3



C6





C9



C7



C10



C8

#25-C449



C11 END





向うのE, Aの  
(Book ①を  
折いて見よ。)



EからBook ①へ

余談 忙しい人は読まない

Eが沈みやすいのは、  
EVAの機体と想定して  
おのの泡波に対応が出来る  
為である。この地下地面(3次元面)  
に於いてはガラス繊維等強化材の他に  
110Vに磁場を発生する装置が泡工  
を起している。磁場の250GHZの交流でEVAの  
機体が磁化し、静電気を帯びる。



25.1からSF  
A(4)

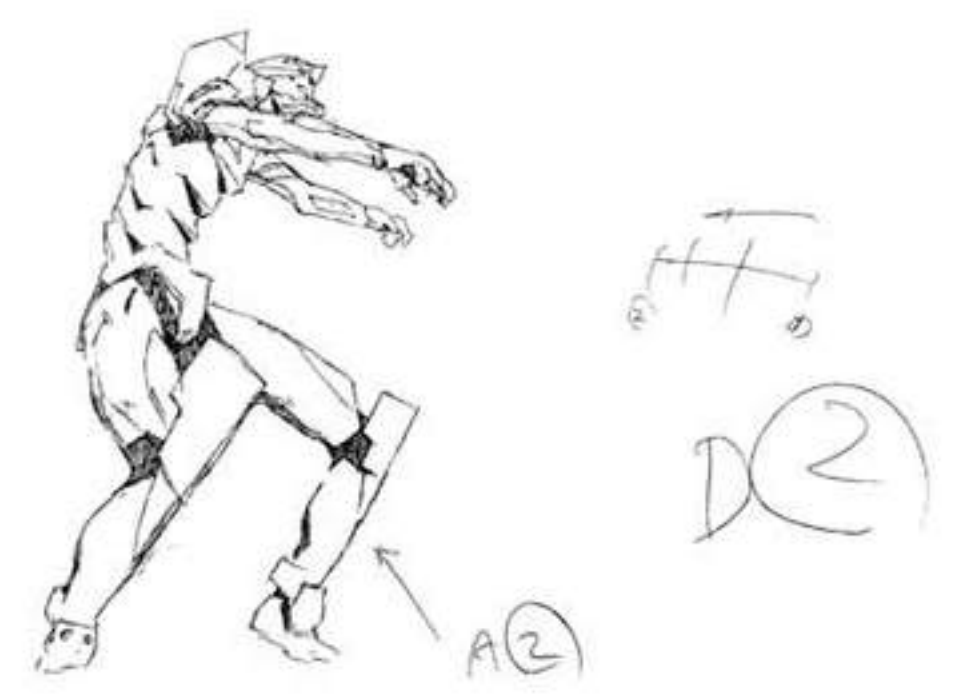

A(2)

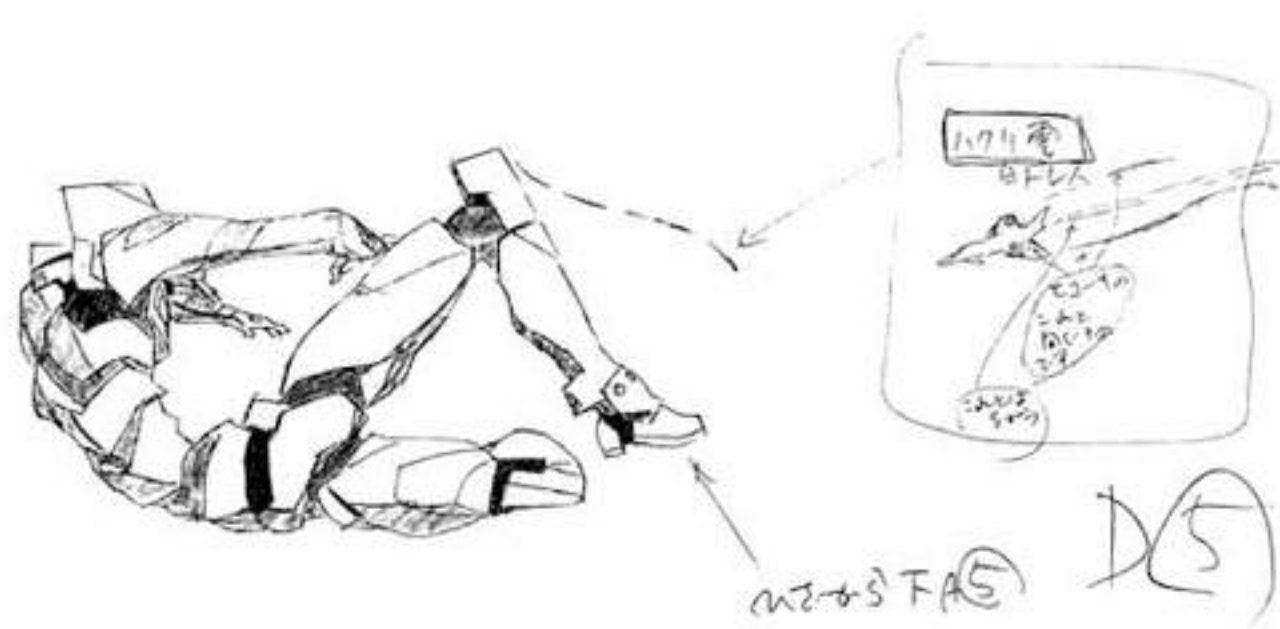

25.2からSF A(5)

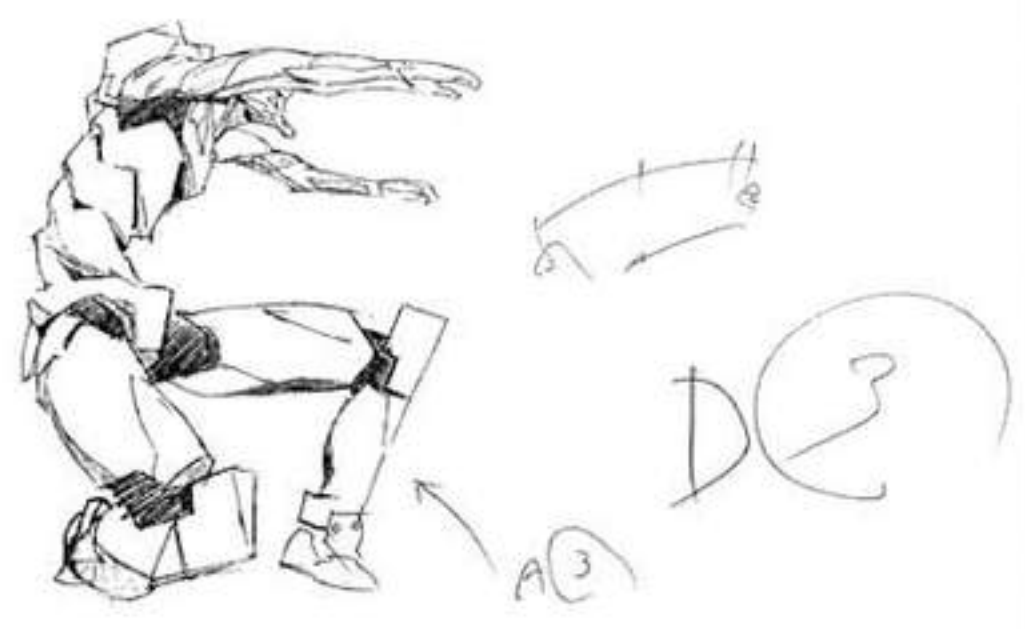

A(3)



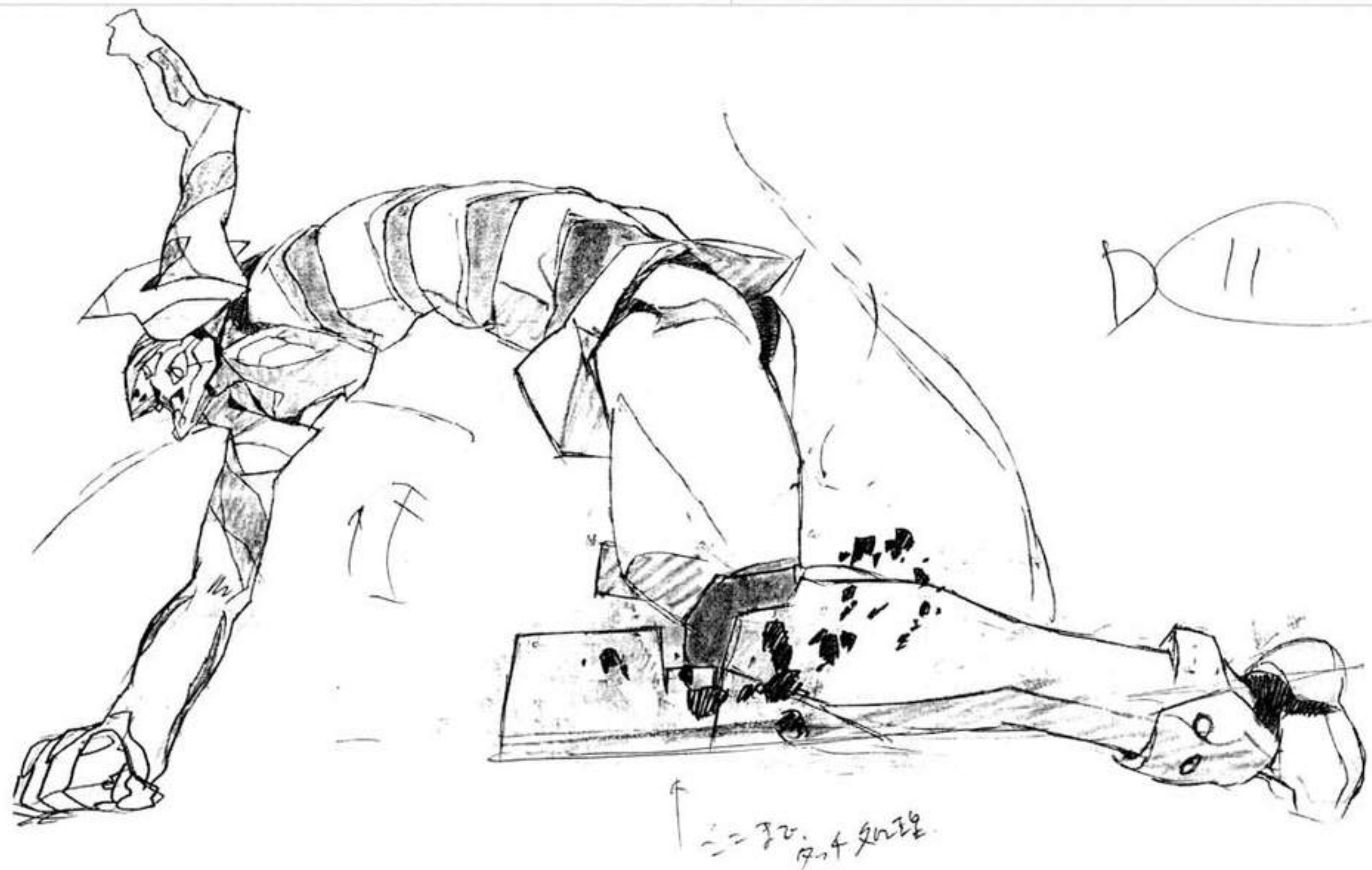
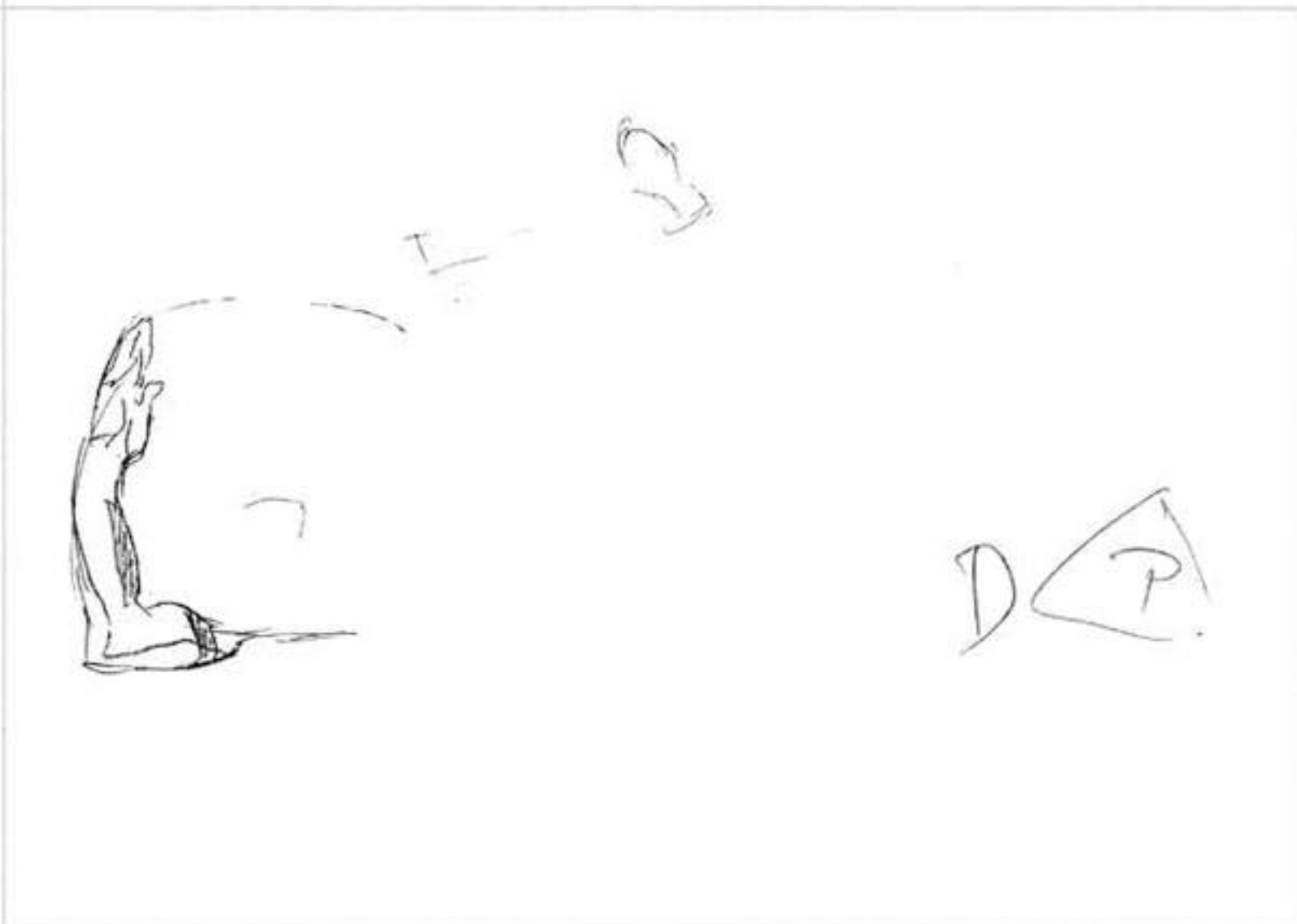
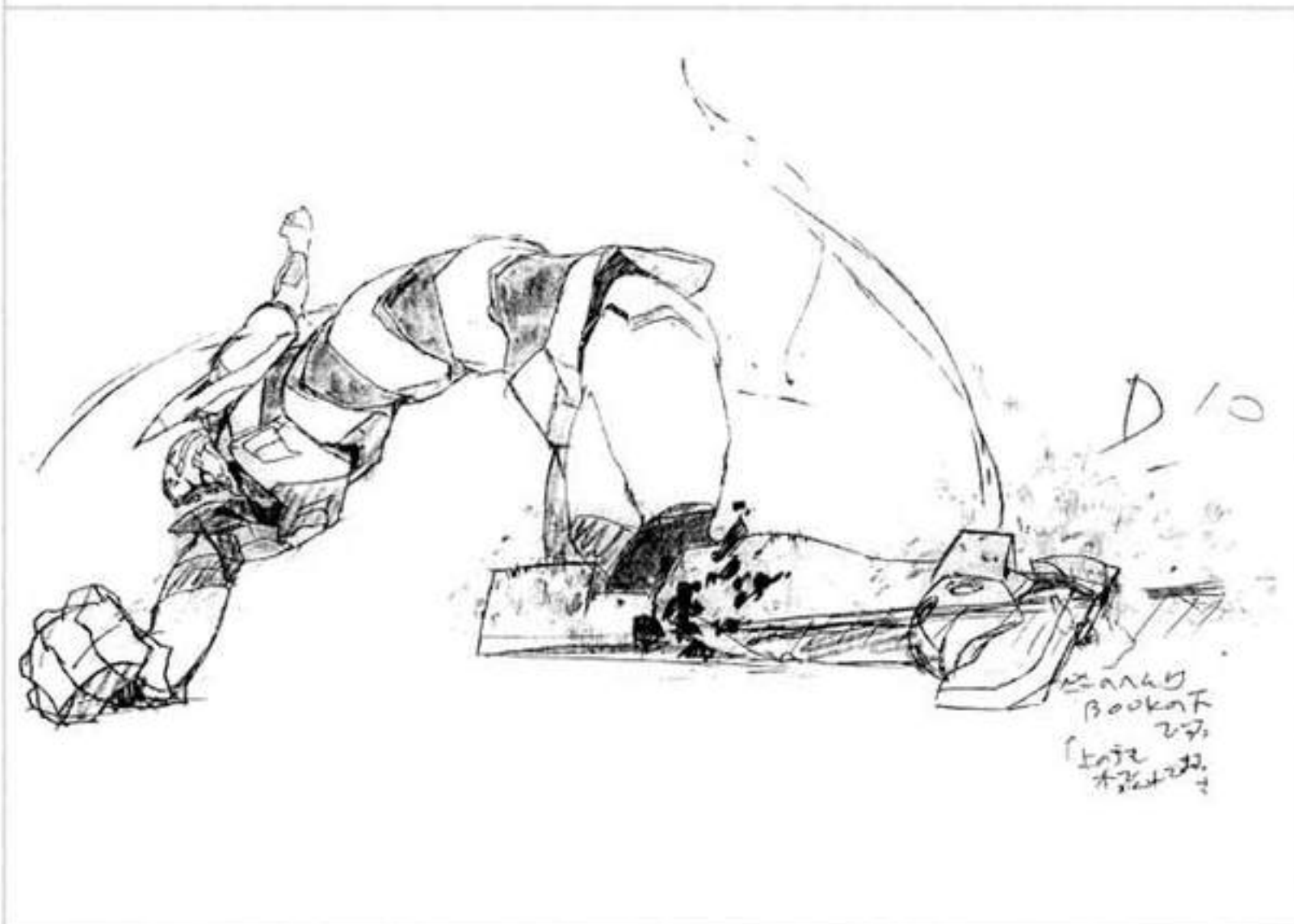
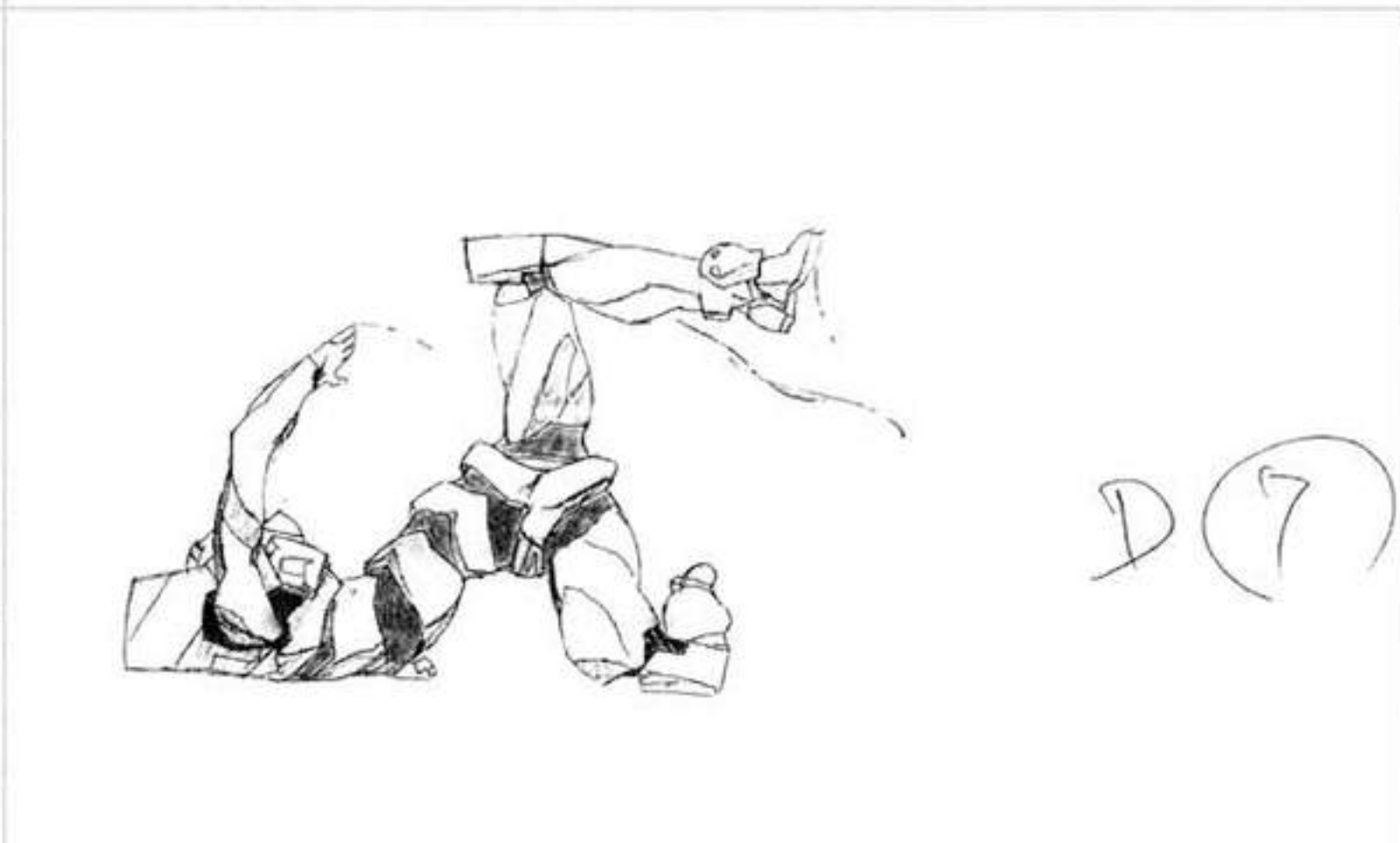
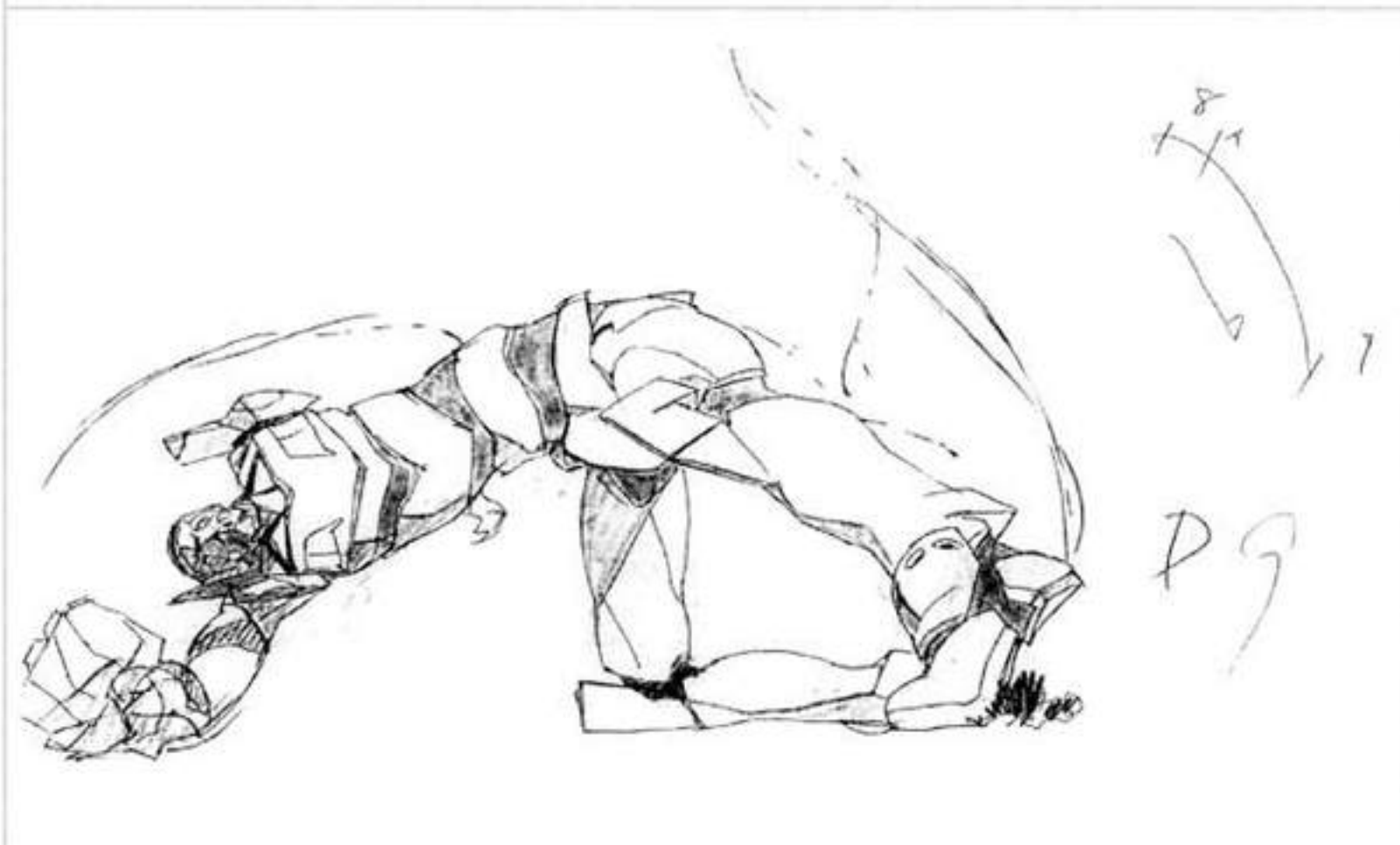
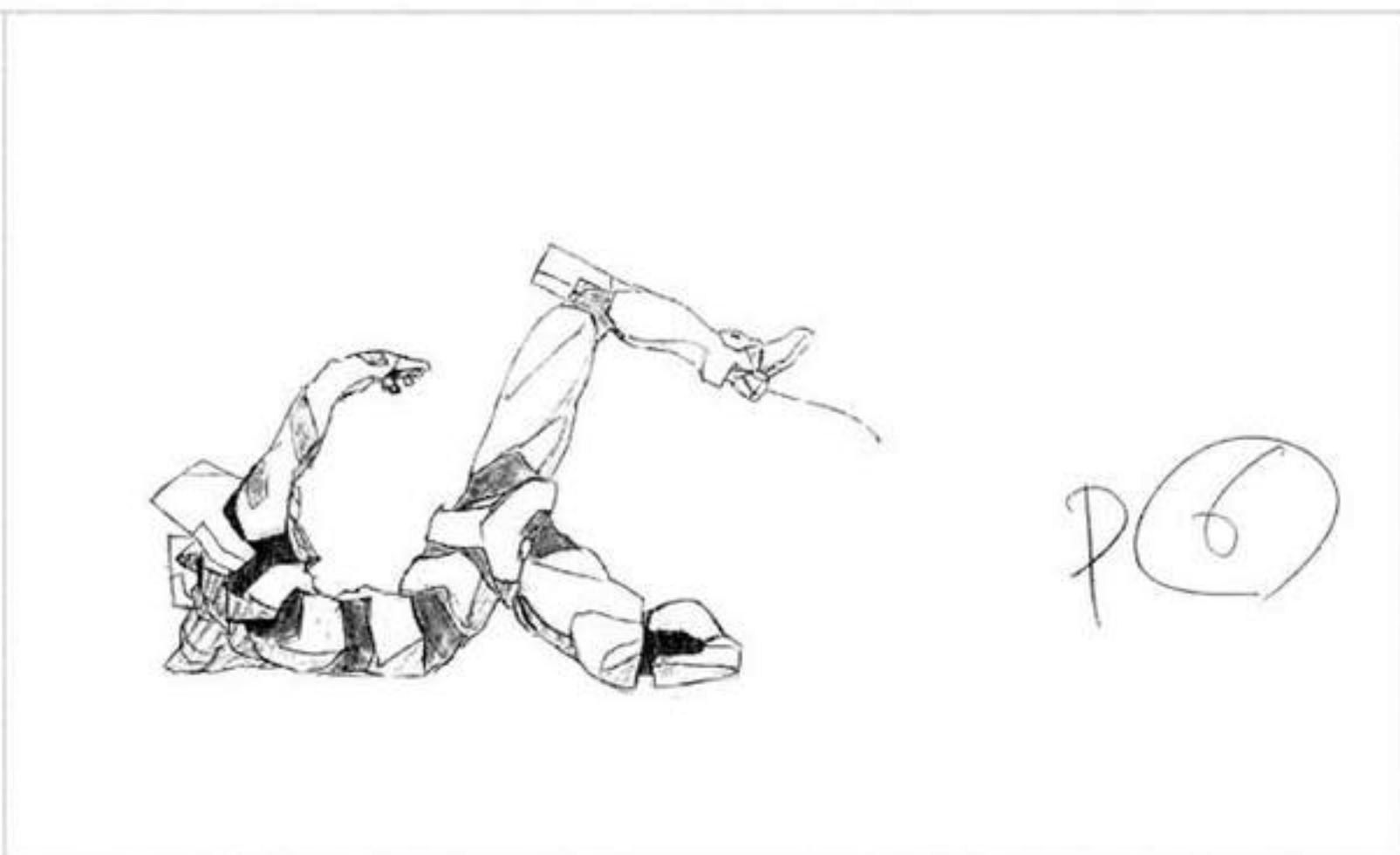
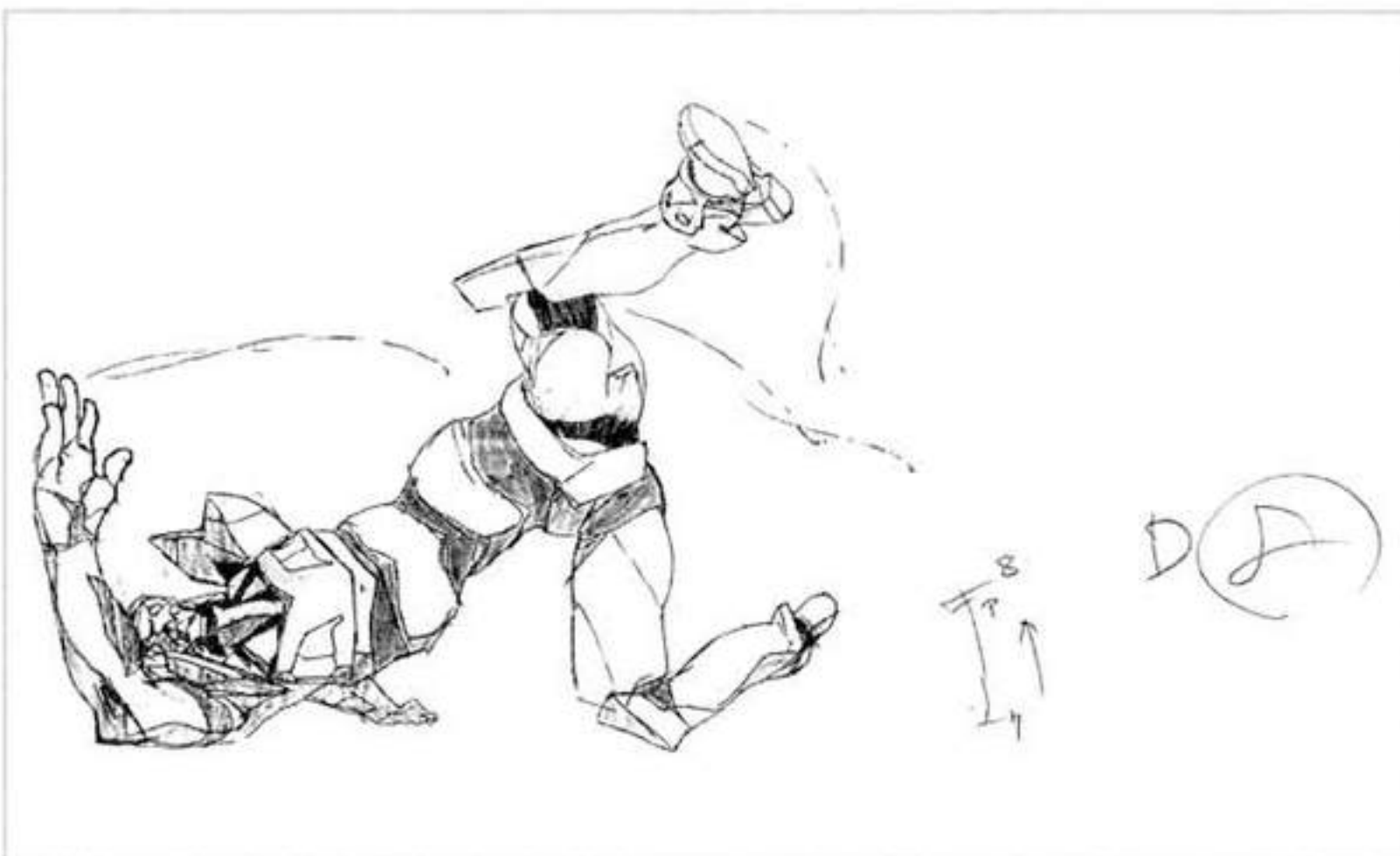



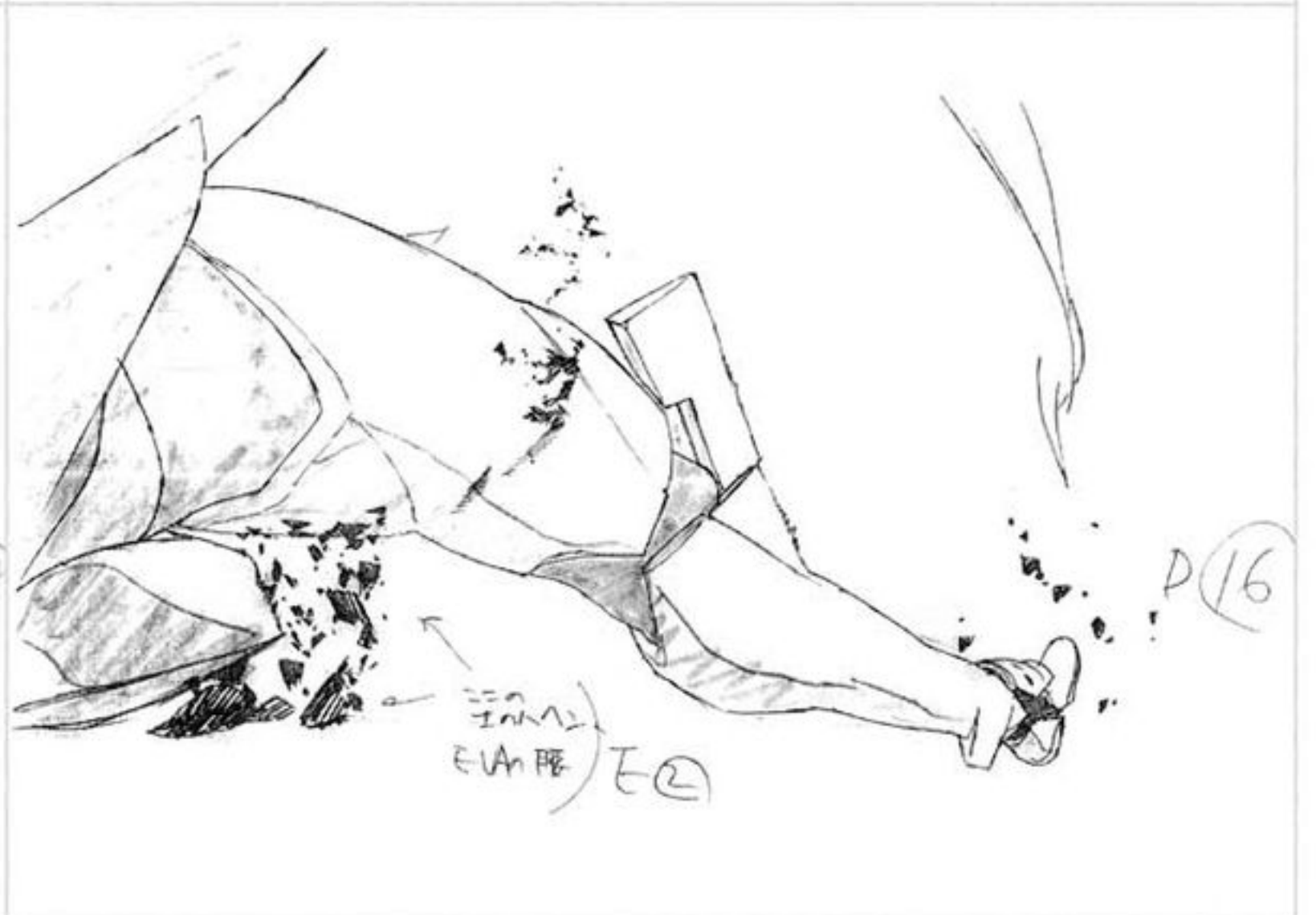
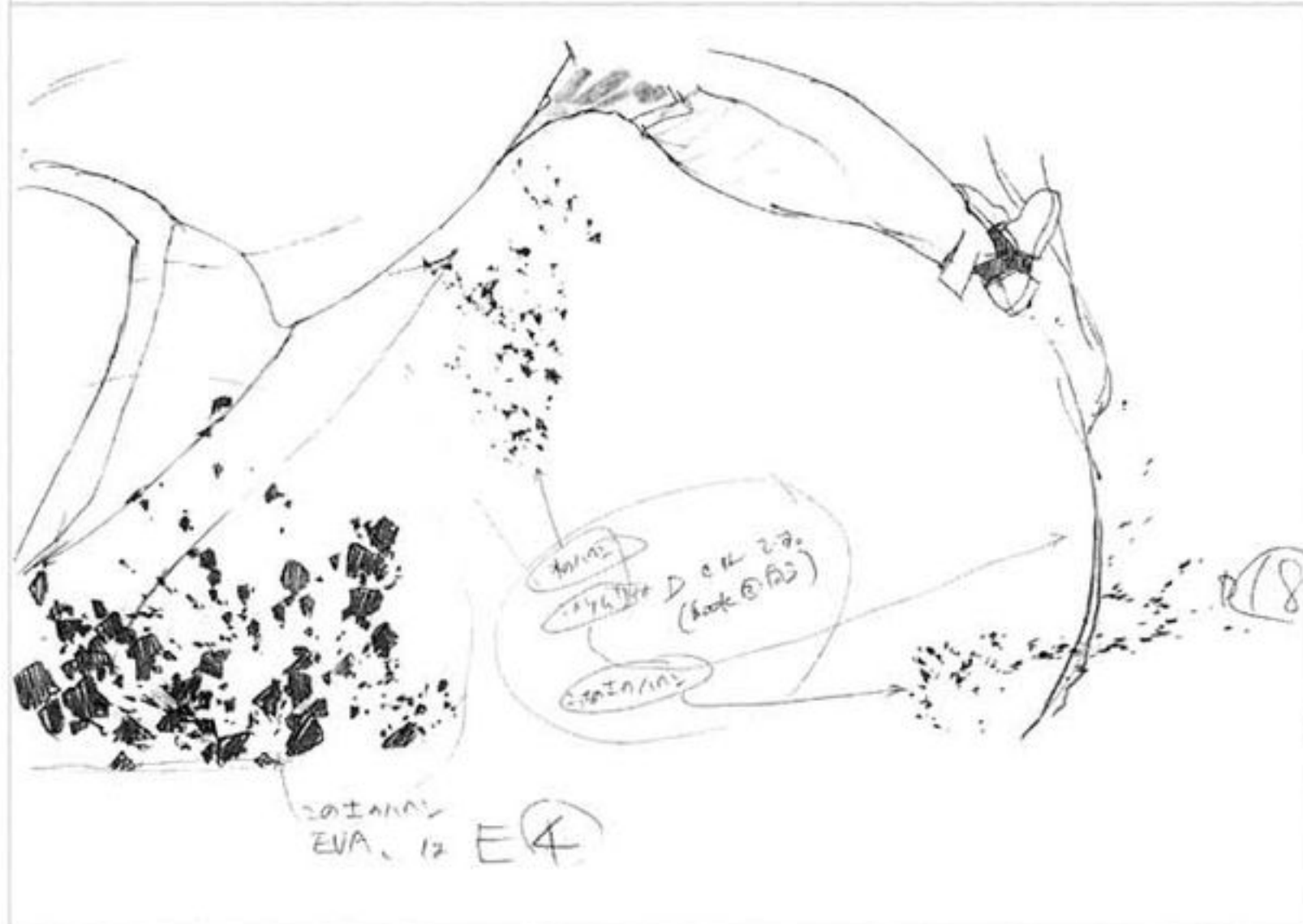
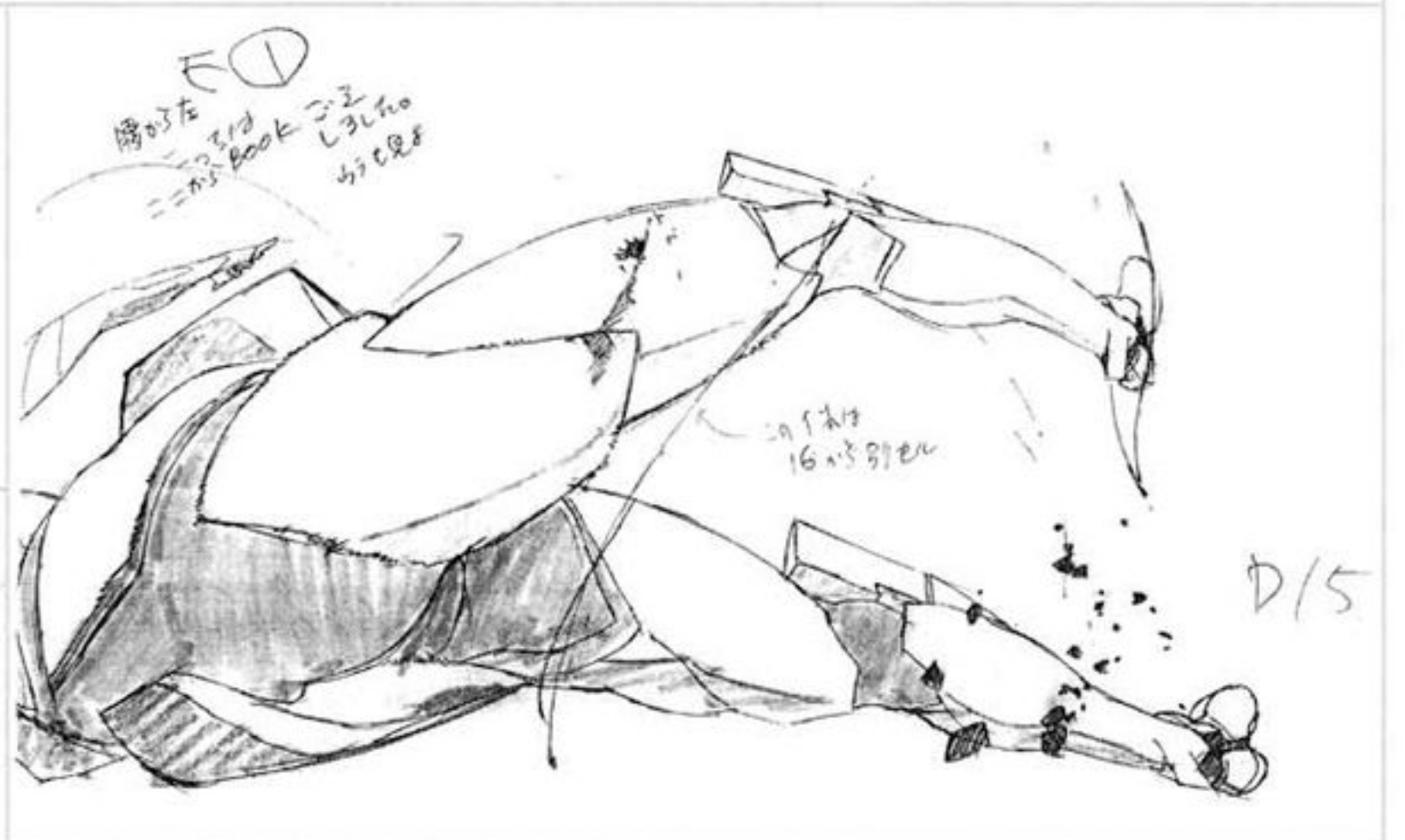
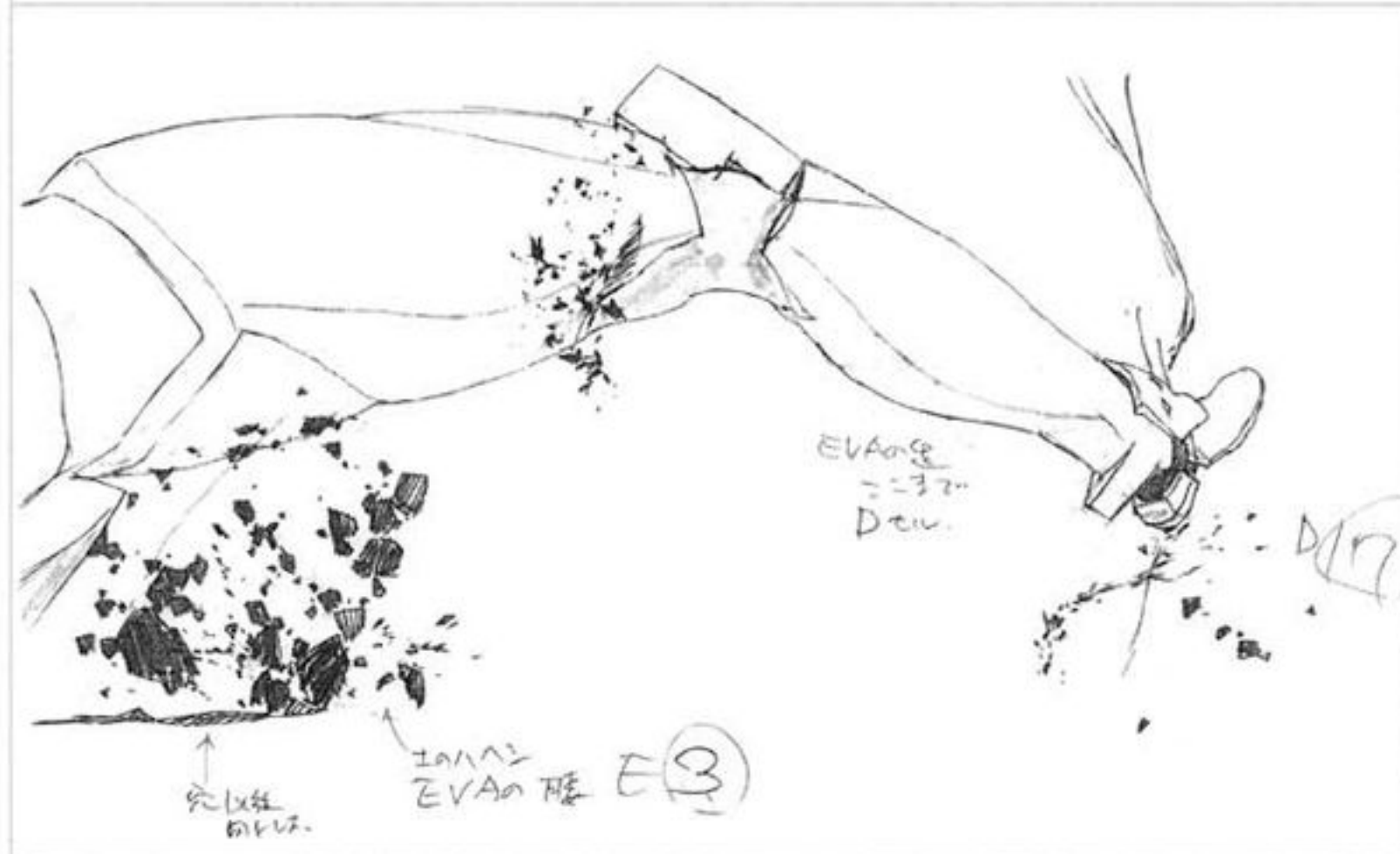
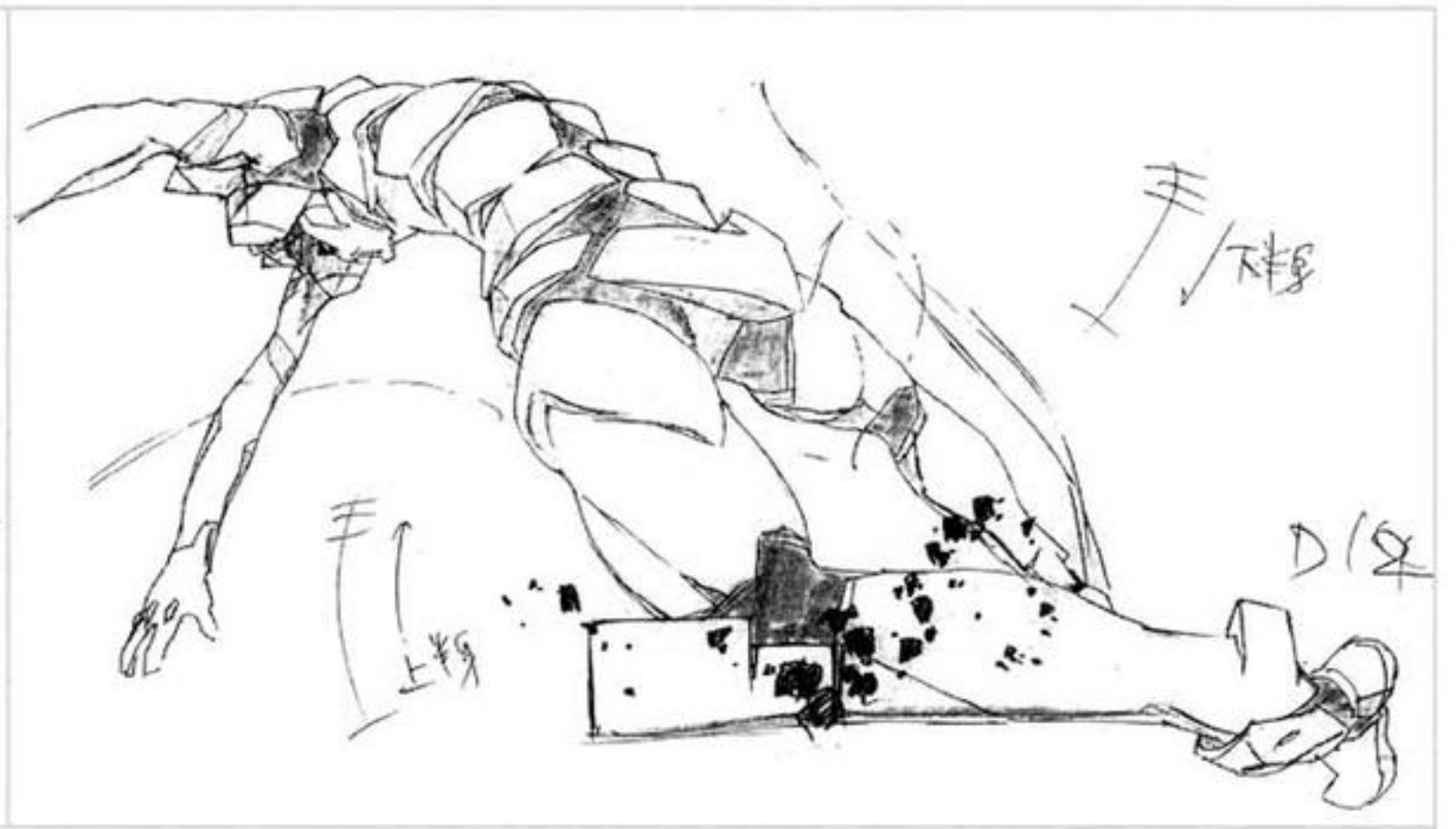
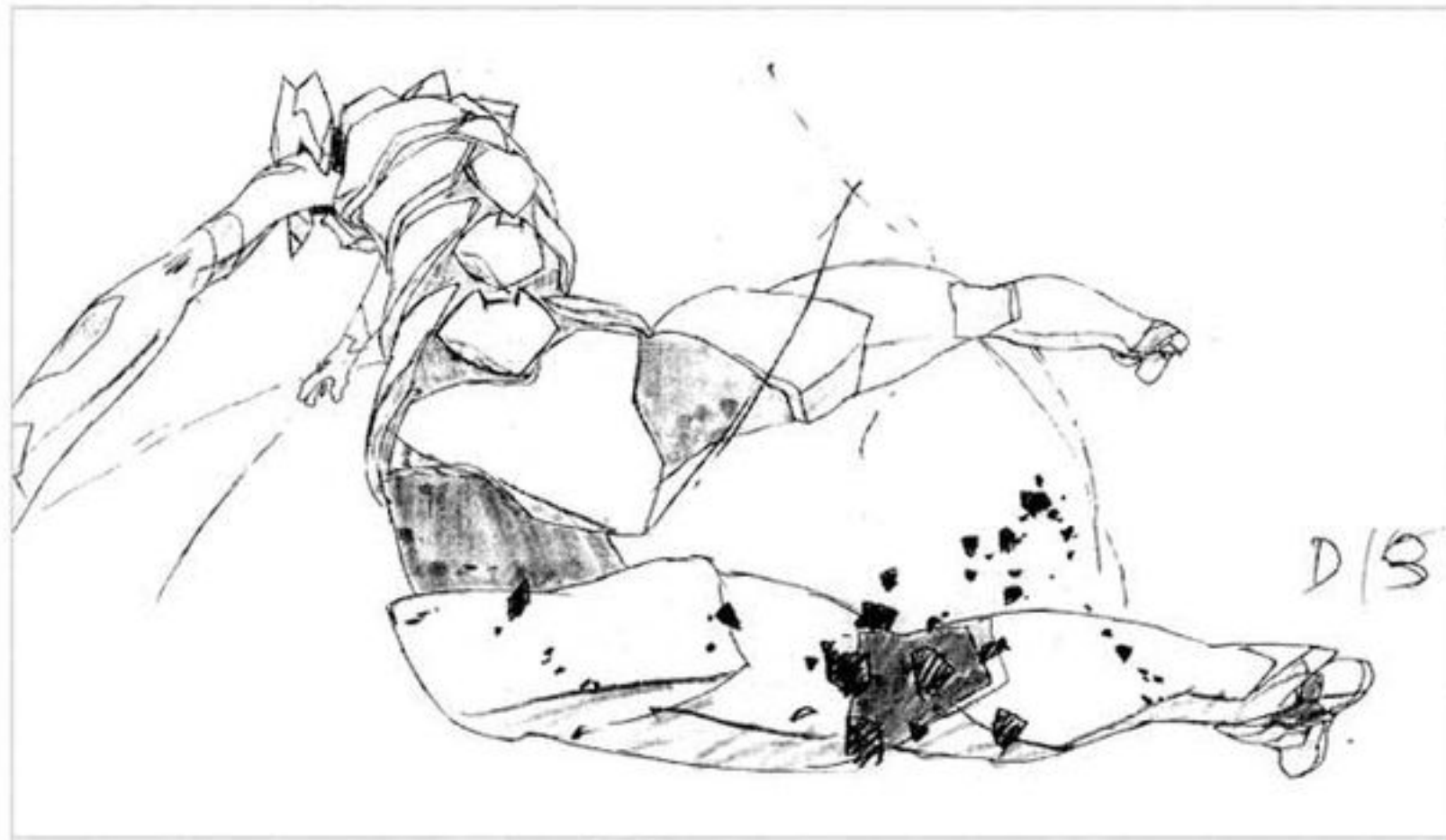



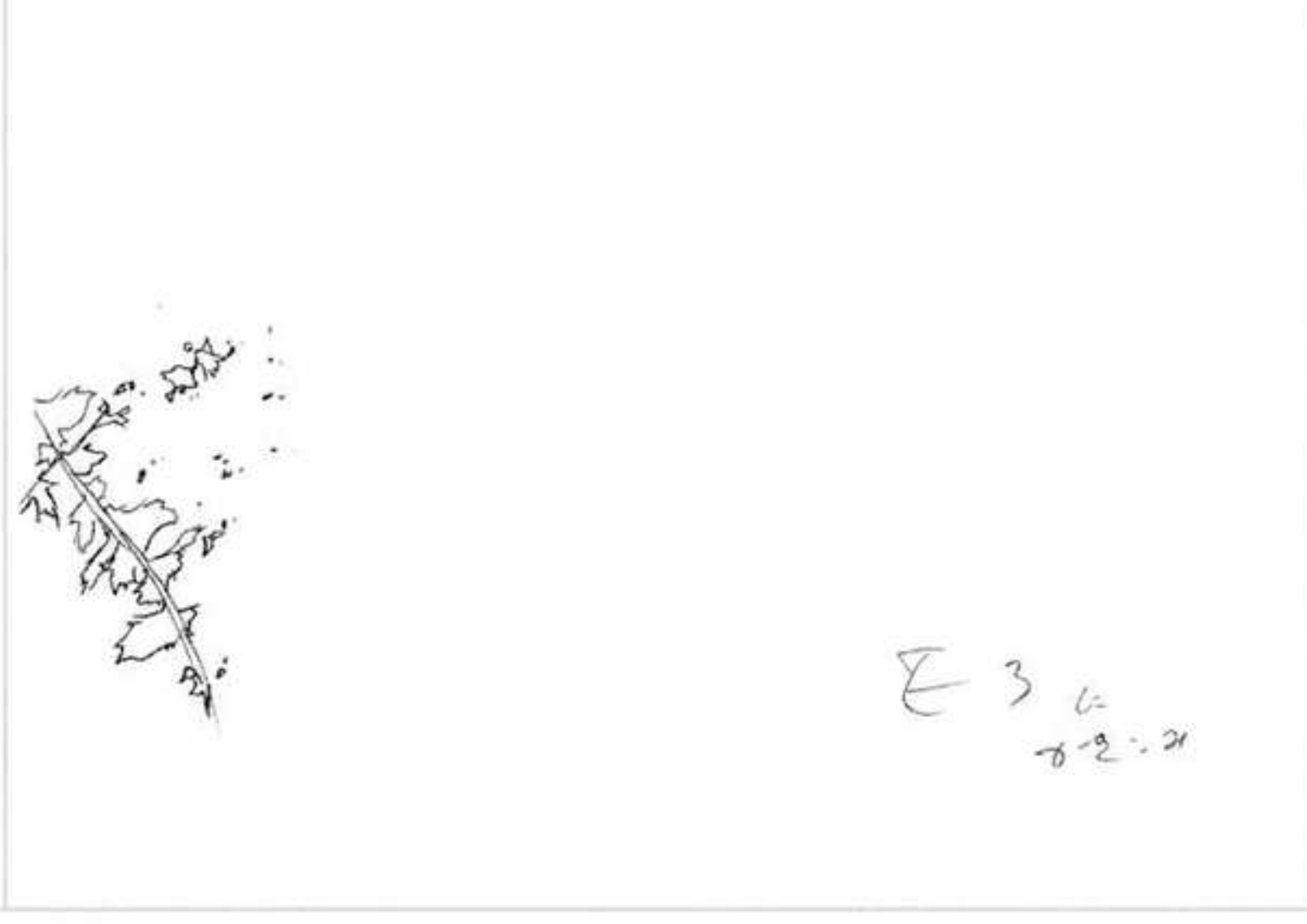
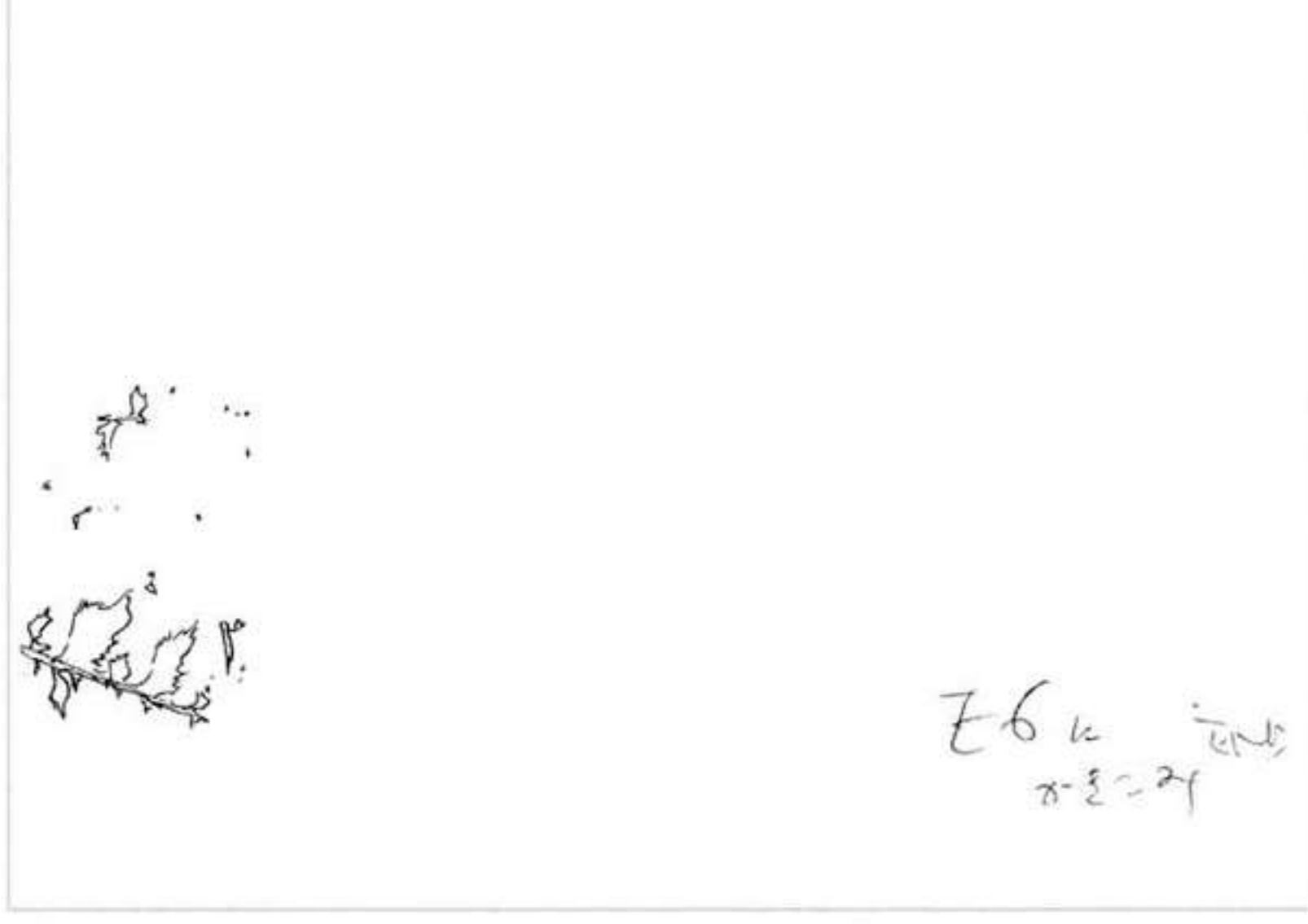
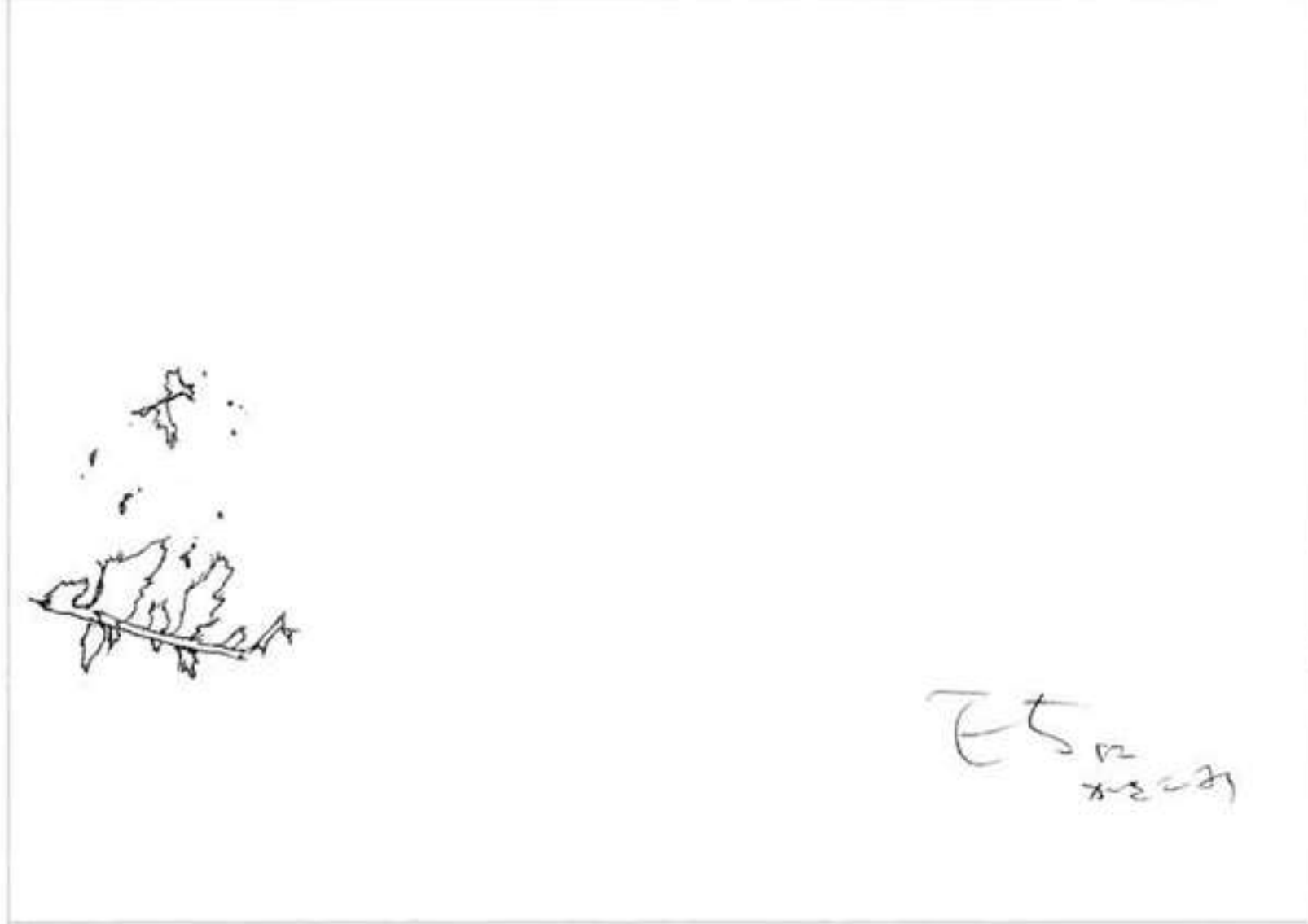
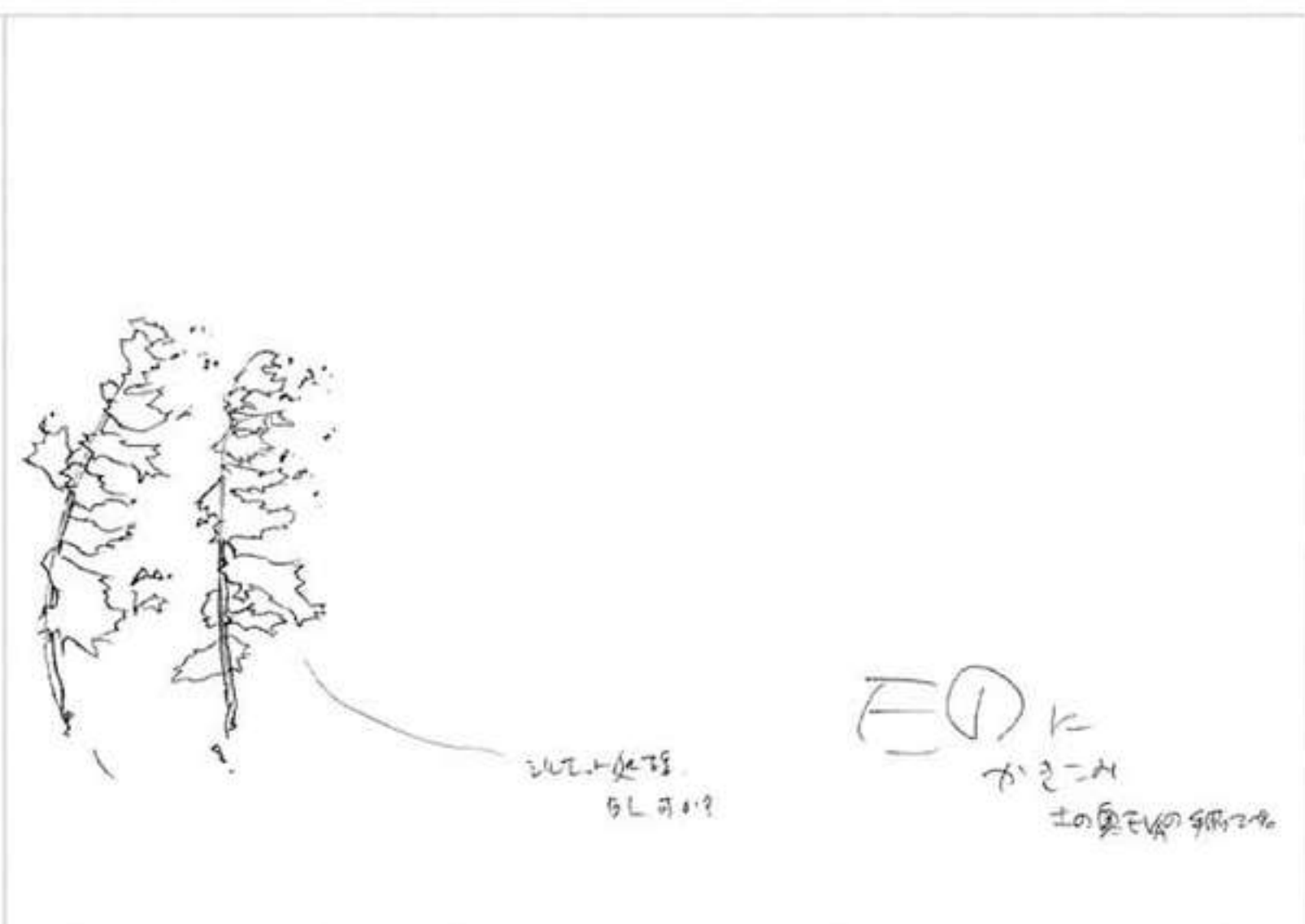
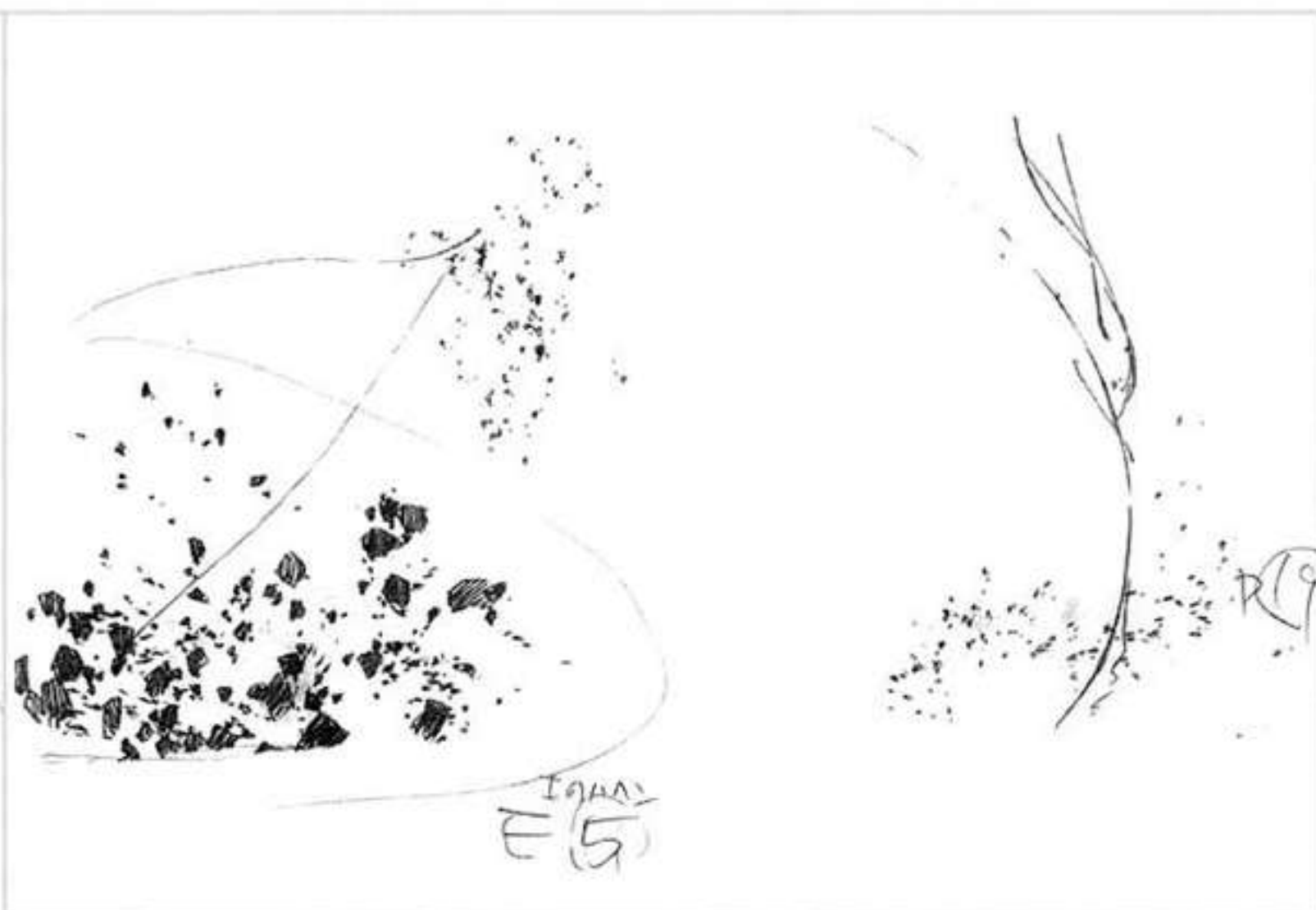



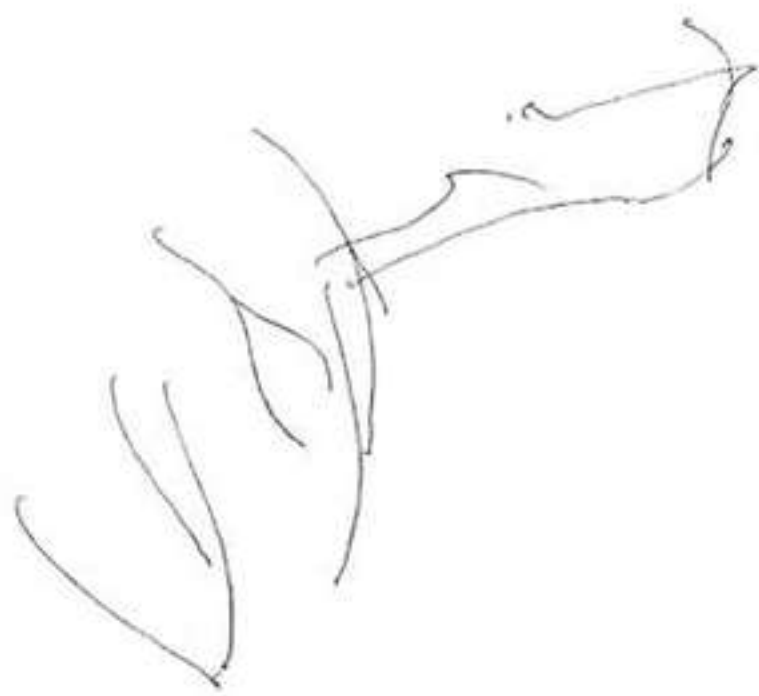

F5



（X）  
P  
BL223.

F1

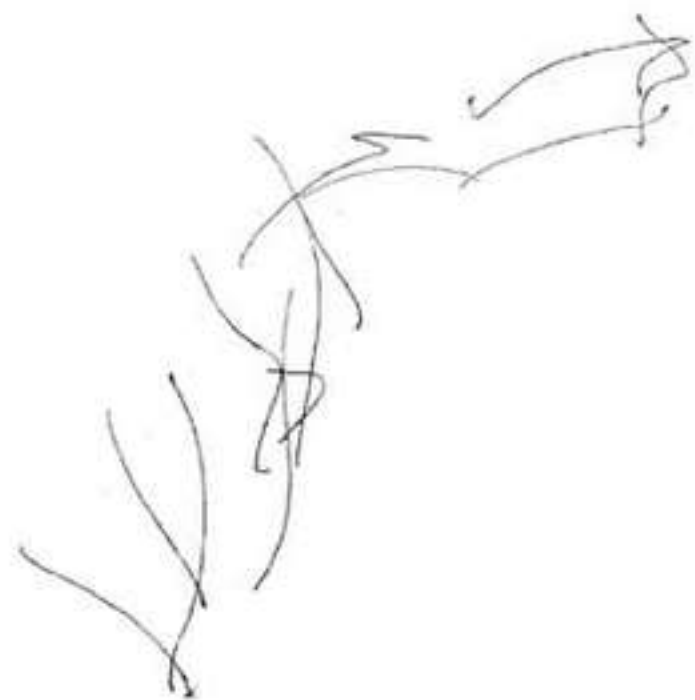

F6  
END

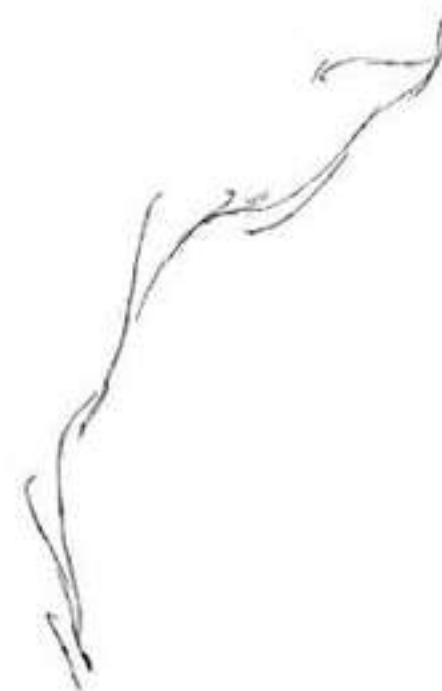

BL223.

F2

90 X



F3

	A	B	C	D	E	F	GN
①	1	X	X	X	X	X	↓
2	2						X
3	3						
4	4						
5	5						
6	6						
7	7						
8	8						
9	9						
10	10						
11	11						
12	12						
13	13						
14	14						
15	15						
16	16						
17	17						
18	18						
19	19						
20	20						
21	21						
22	22						
23	23						
24	24						

1	2	26
10	8	28
2	4	30
10	3	32
11	4	34
12		36
13	5	38
13		40
14	6	42
14	6	44
15	13	46
15	14	48

1	5	50
16	2	52
16	17	54
18	4	56
19	5	58
20	6	60

タイムシート

#25-C449



F4



A	B	C	D	E	F
1	1	1	1	1	1
2	1	1	1	1	1
3	1	1	1	1	1
4	1	1	1	1	1
5	1	1	1	1	1
6	1	1	1	1	1
7	1	1	1	1	1
8	1	1	1	1	1
9	1	1	1	1	1
10	1	1	1	1	1
11	1	1	1	1	1
12	1	1	1	1	1
13	1	1	1	1	1
14	1	1	1	1	1
15	1	1	1	1	1
16	1	1	1	1	1
17	1	1	1	1	1
18	1	1	1	1	1
19	1	1	1	1	1
20	1	1	1	1	1
21	1	1	1	1	1
22	1	1	1	1	1
23	1	1	1	1	1
24	1	1	1	1	1
25	1	1	1	1	1
26	1	1	1	1	1
27	1	1	1	1	1
28	1	1	1	1	1
29	1	1	1	1	1
30	1	1	1	1	1
31	1	1	1	1	1
32	1	1	1	1	1
33	1	1	1	1	1
34	1	1	1	1	1
35	1	1	1	1	1
36	1	1	1	1	1
37	1	1	1	1	1
38	1	1	1	1	1
39	1	1	1	1	1
40	1	1	1	1	1
41	1	1	1	1	1
42	1	1	1	1	1

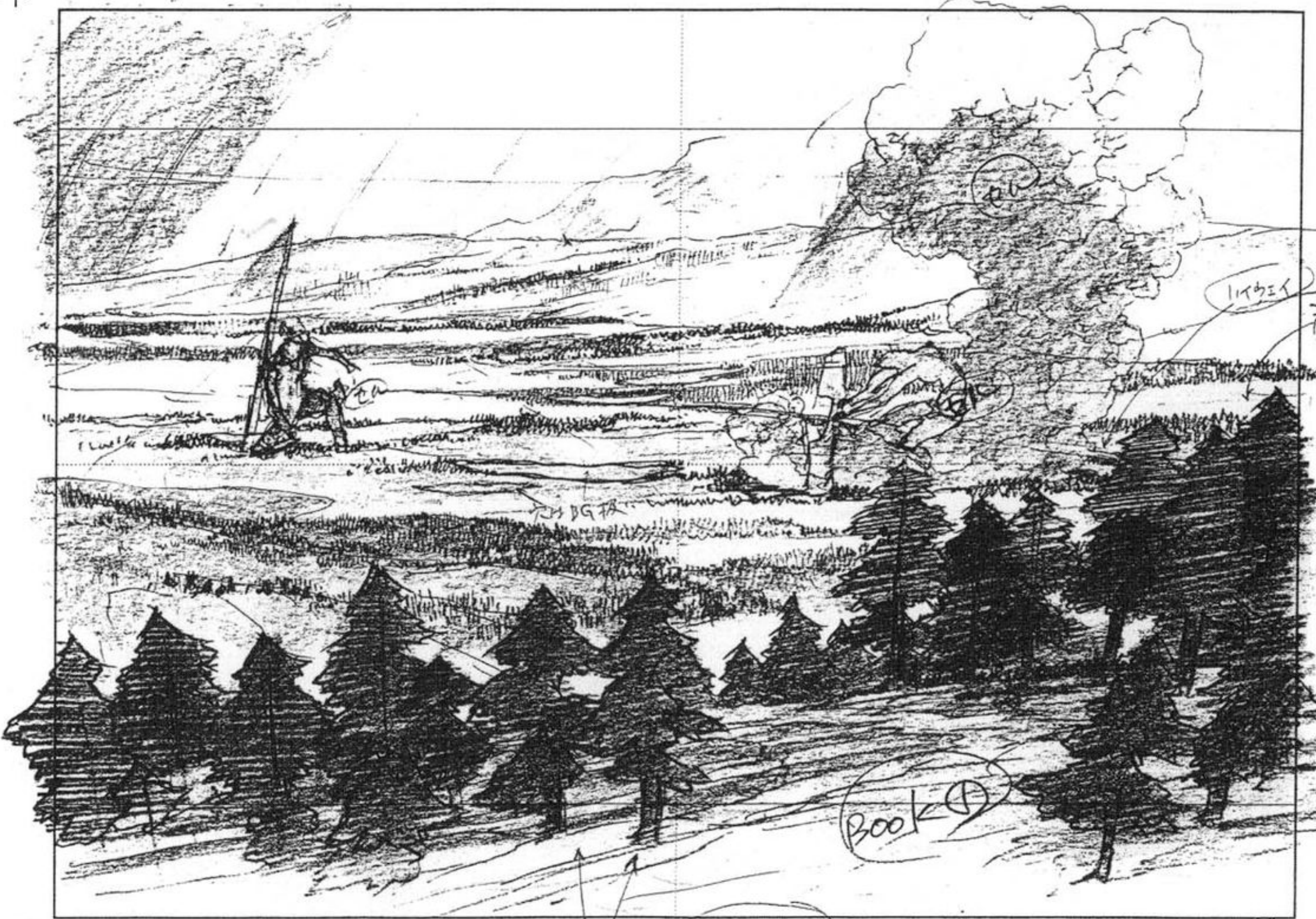

#25-C450レイアウト

Book 2

Book 2 Book 3 Book 4  
分けて下す。



A3



煙色

A1

下の線果線



下のキハキハ合紙

B2



B1



↑ 煙色

A2

本ページの用紙を3リヤ用紙



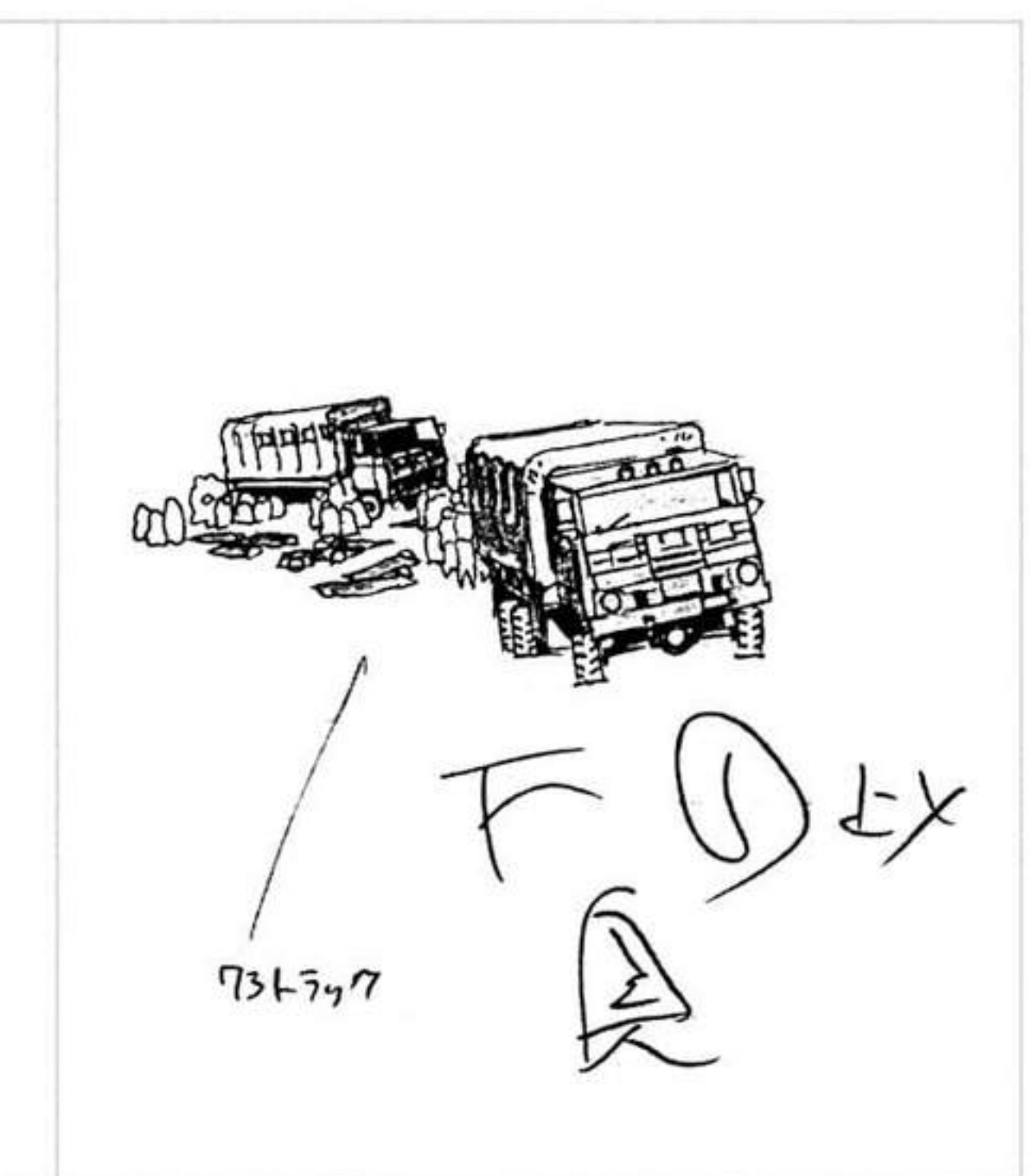
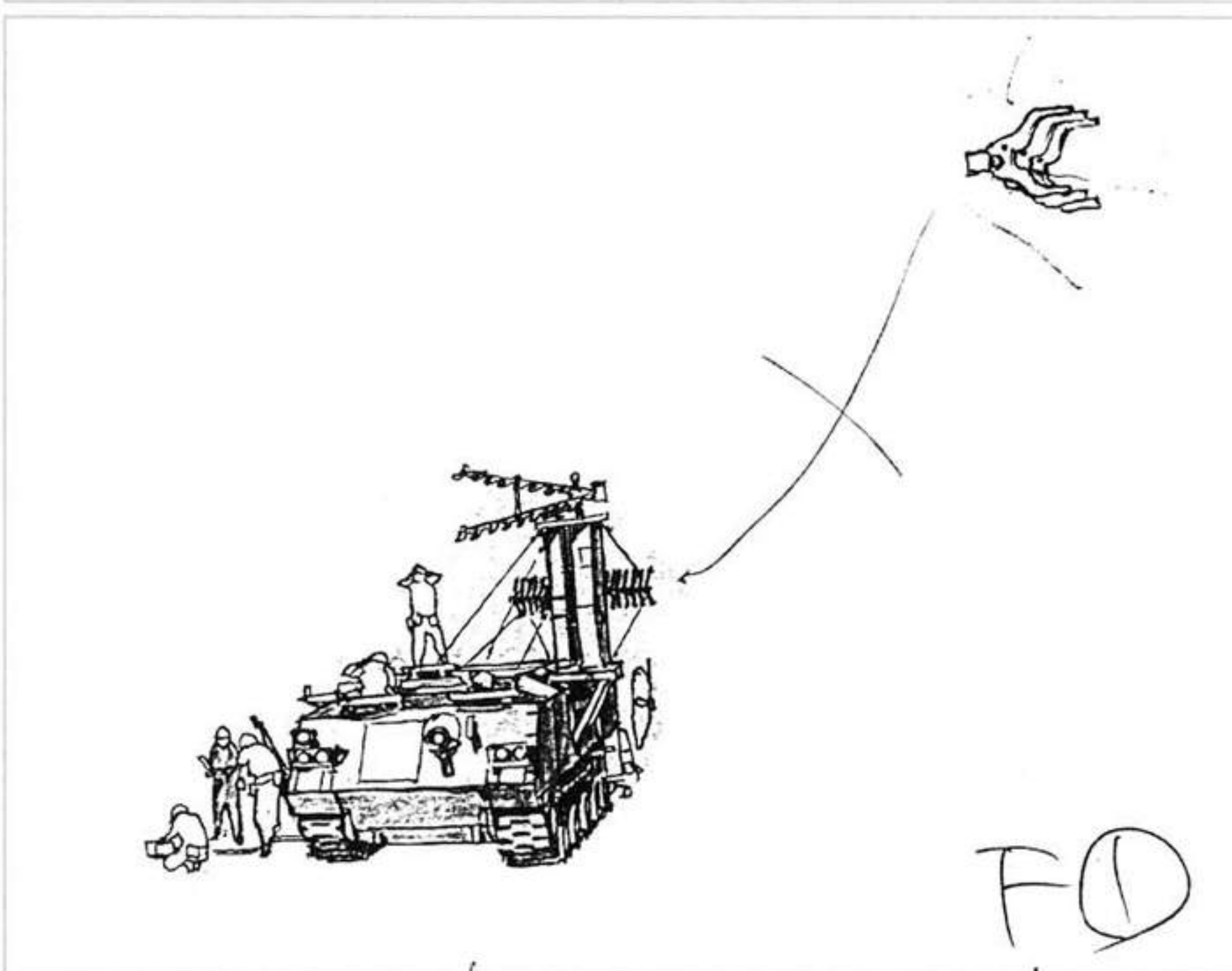
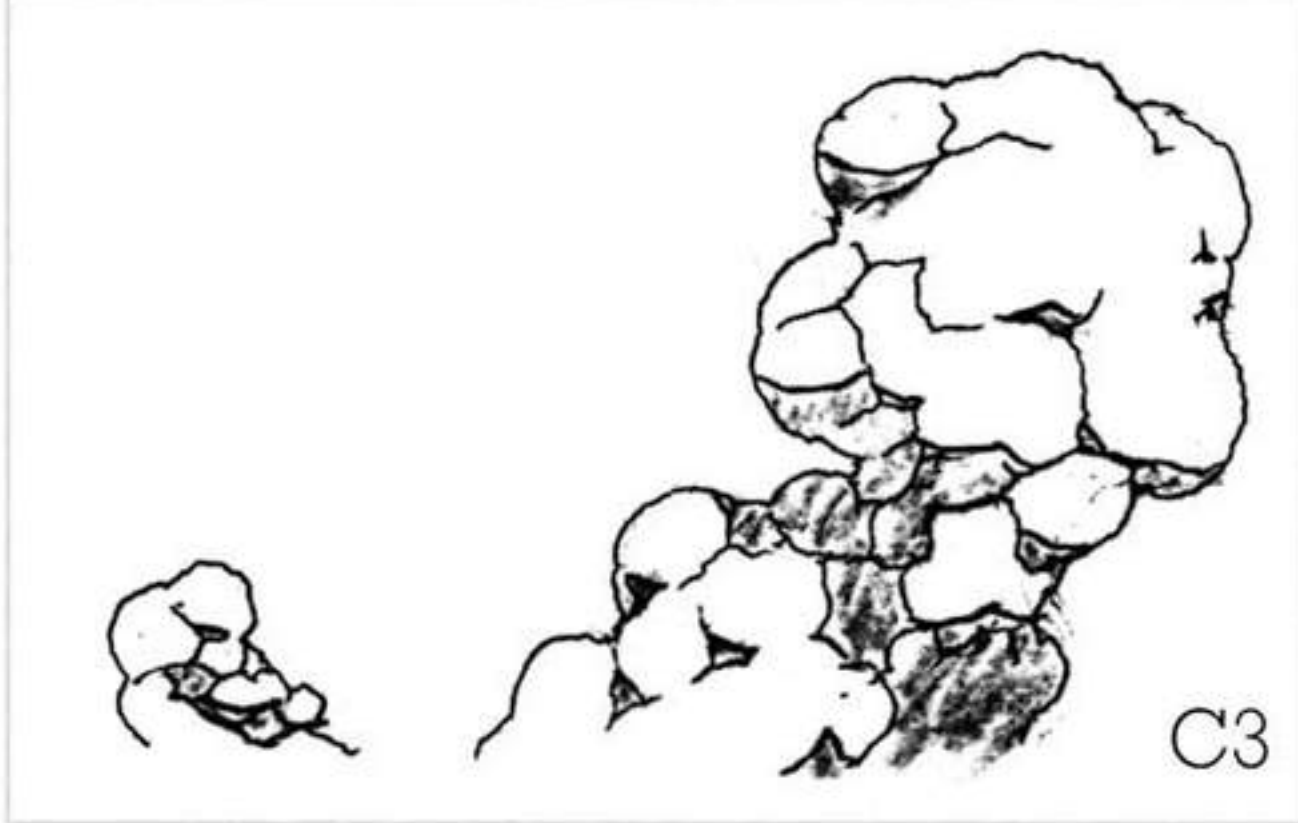
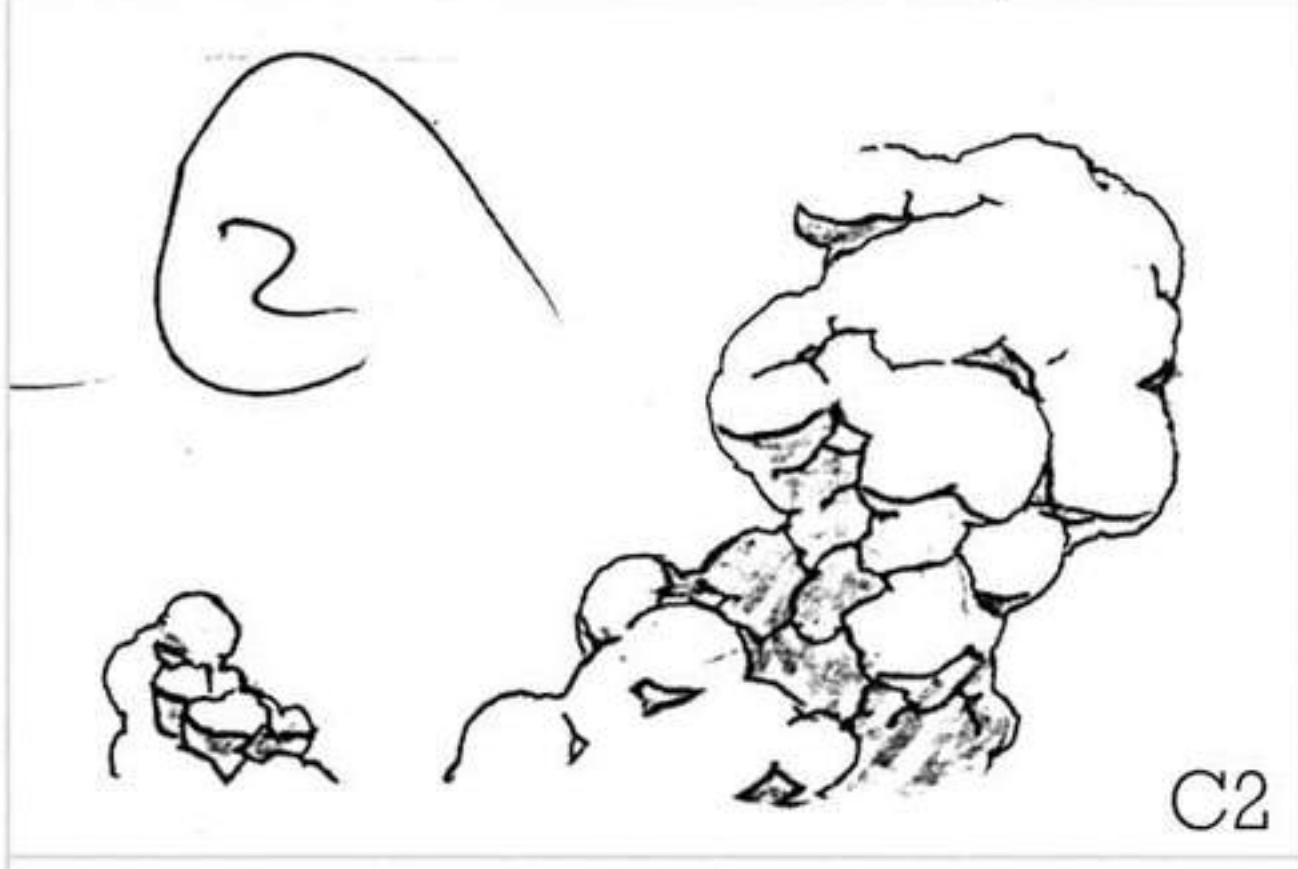
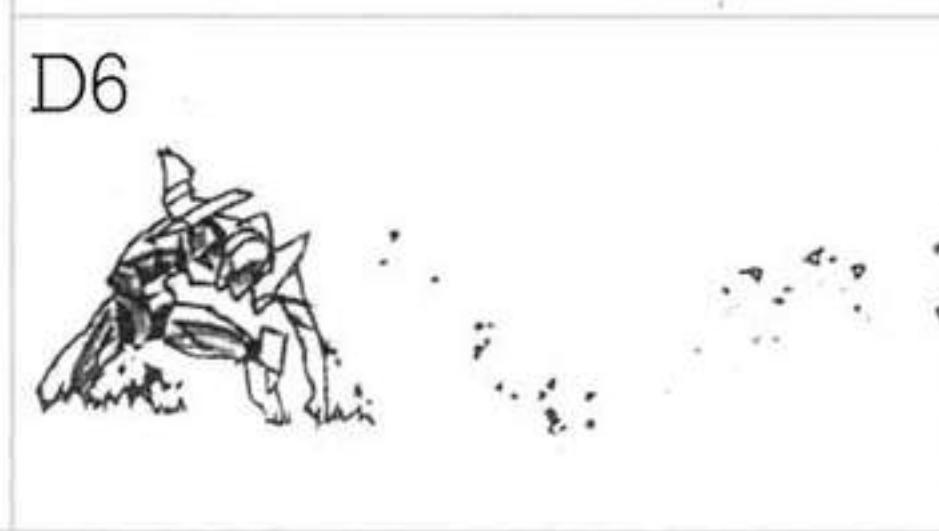
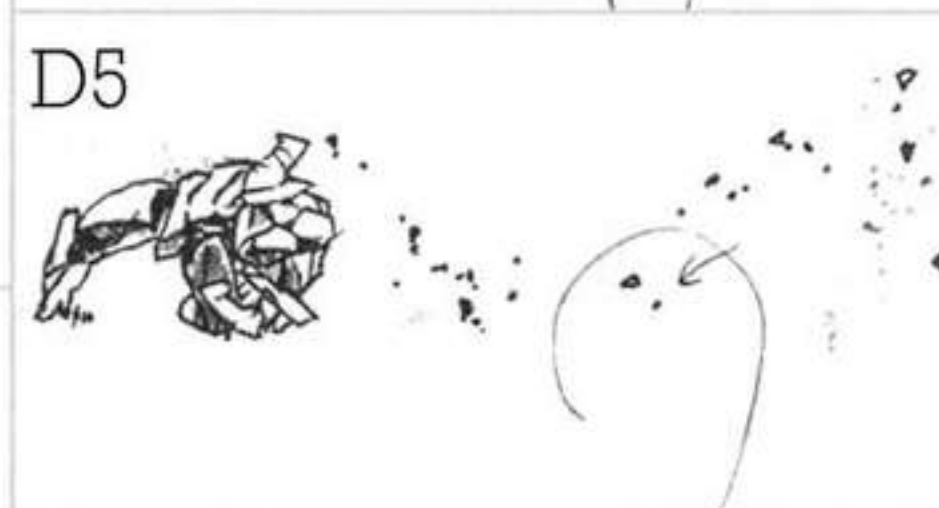
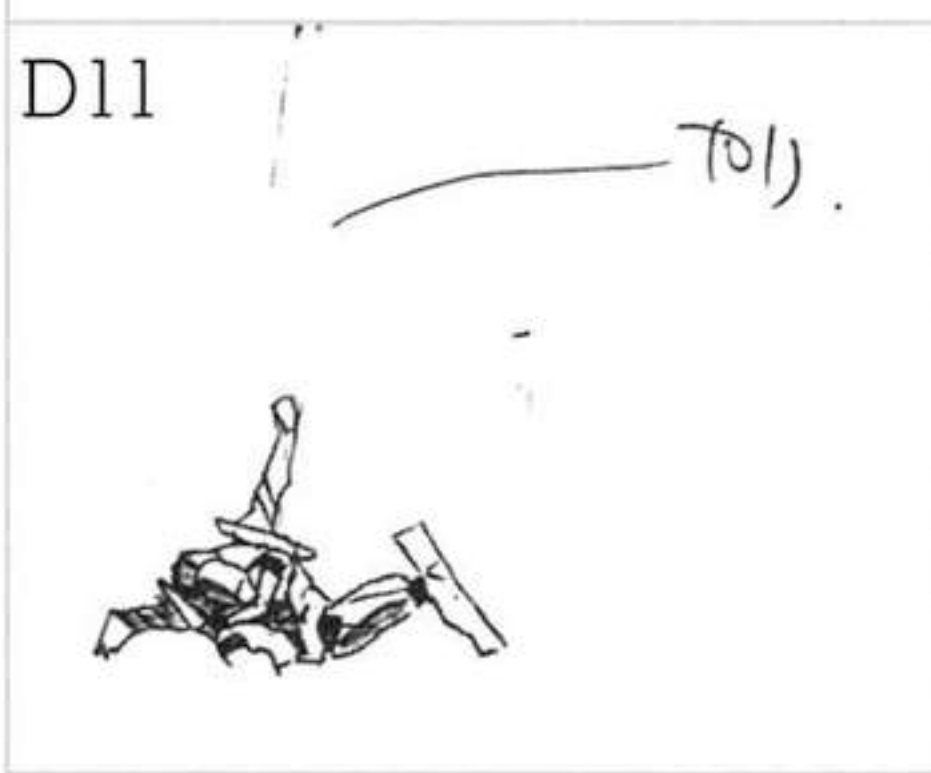
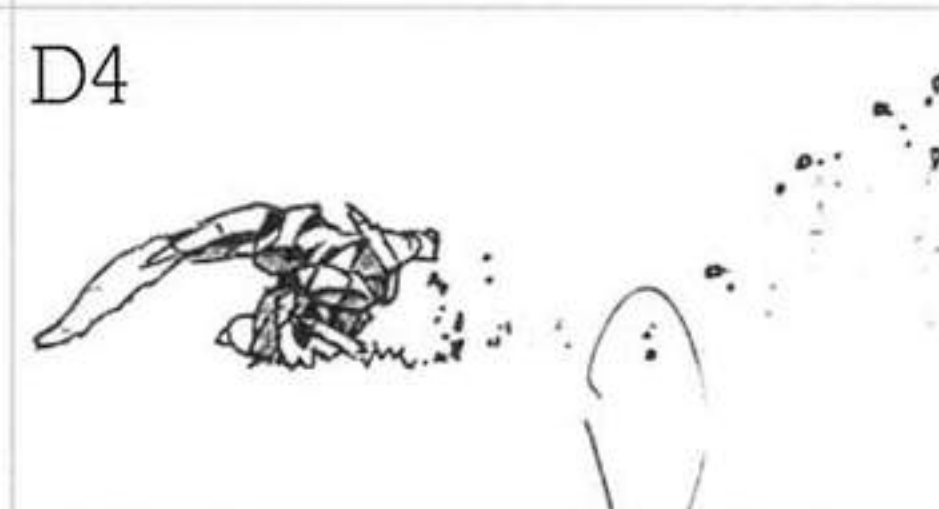
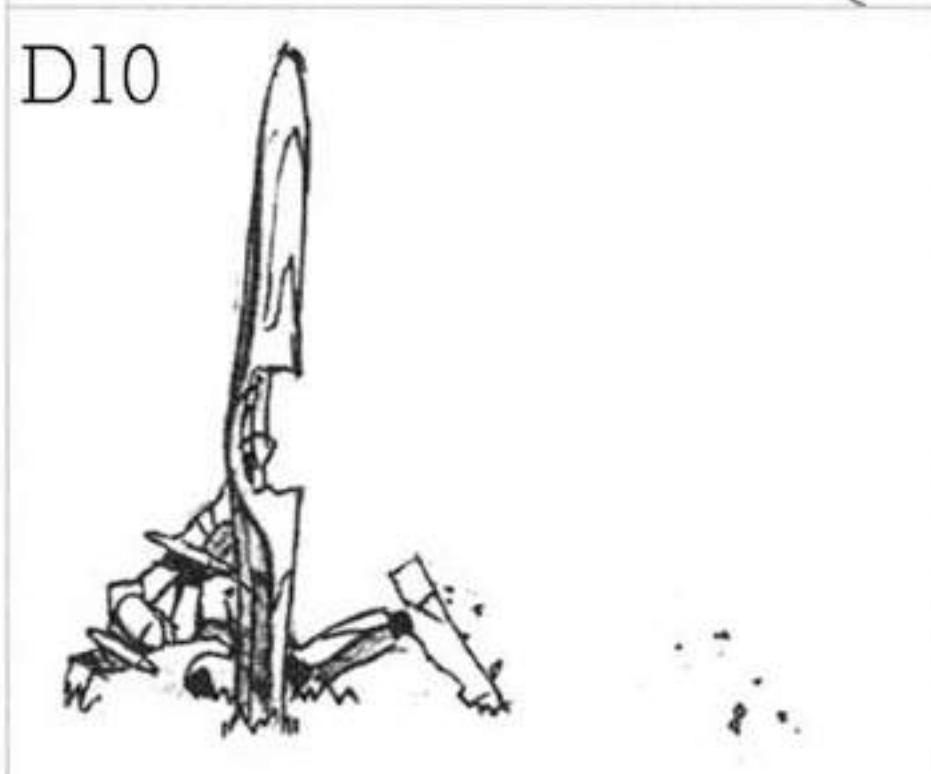
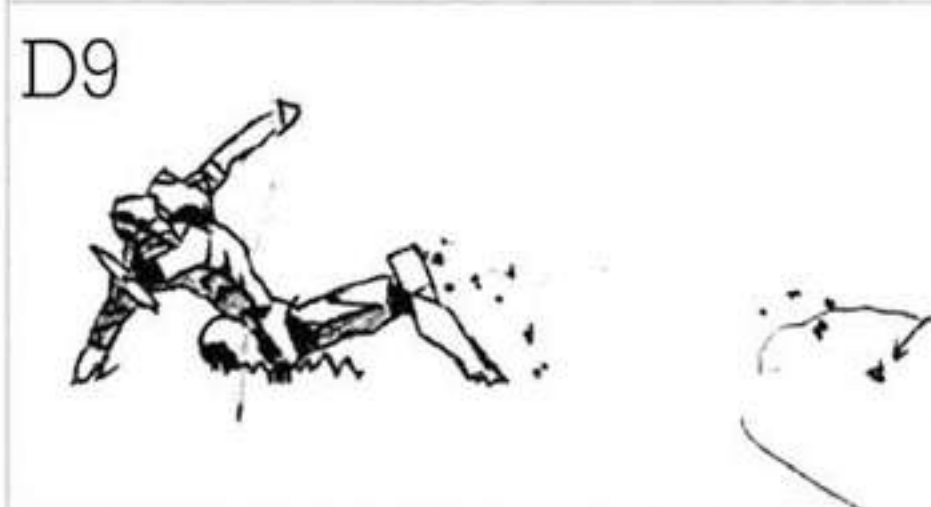



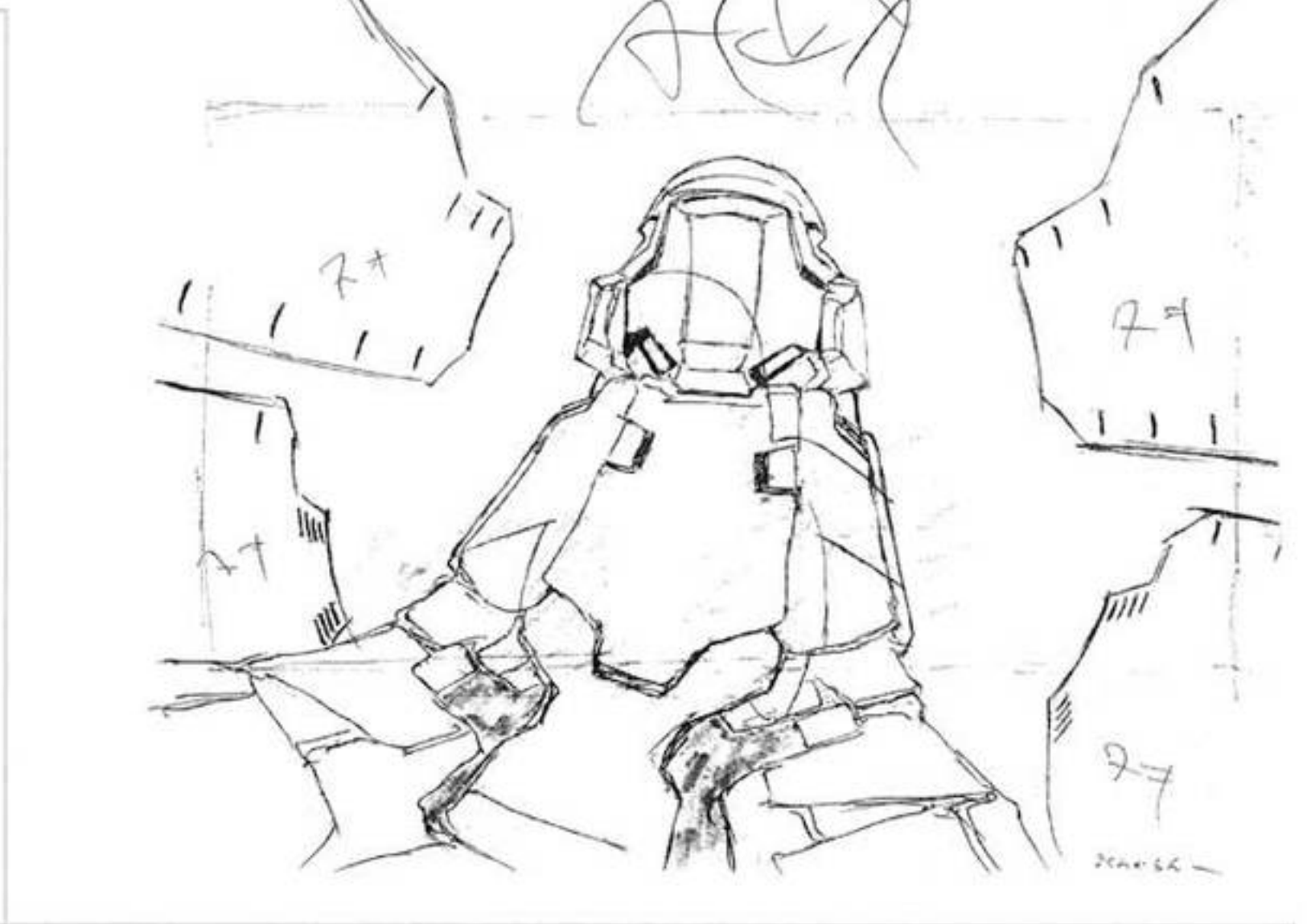

#25-C451







AB	
0	2
/	4
②	6
/	8
/	10
③	12
④	14
/	16
⑤	18
/	20
/	22
⑥	24
/	26
/	28
/	30
⑦	32
/	34
⑧	36
/	38
/	40
⑨	42

タイムシート





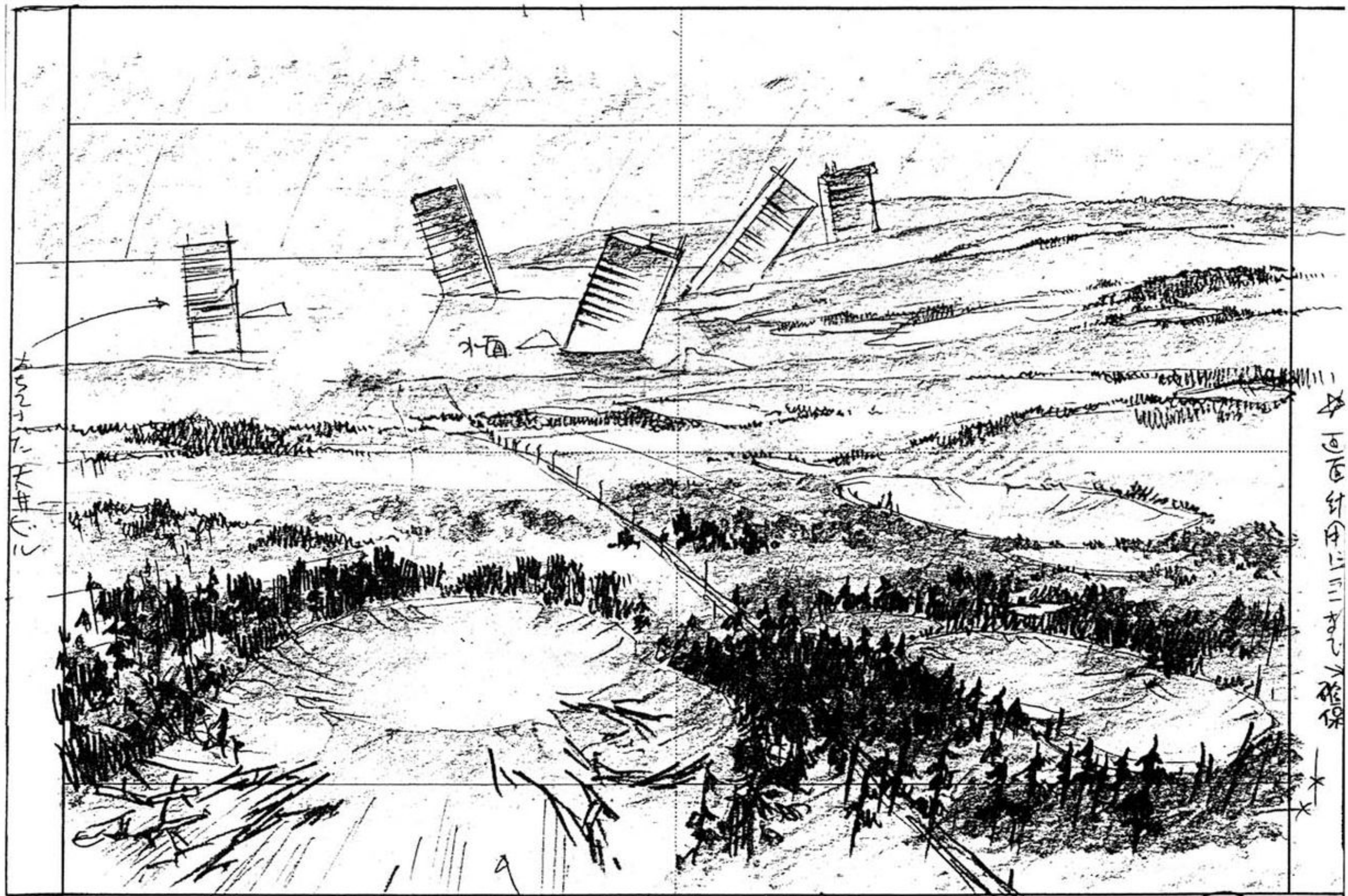

#25-C452,454 レイアウト

↑ハイハイ  
7号

砲撃で穴  
空cut 2号はこの穴の入り口

(5) (4)



3

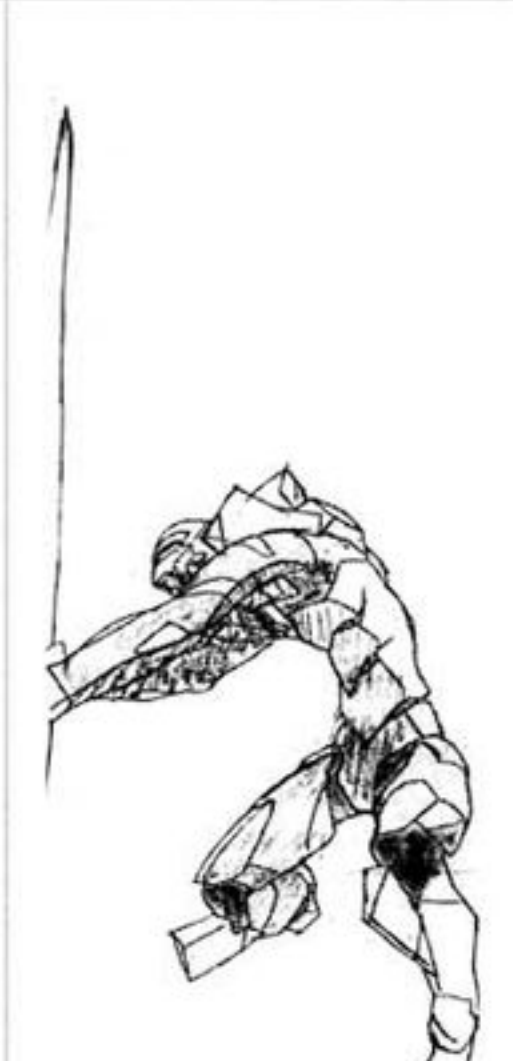

(A) (1)

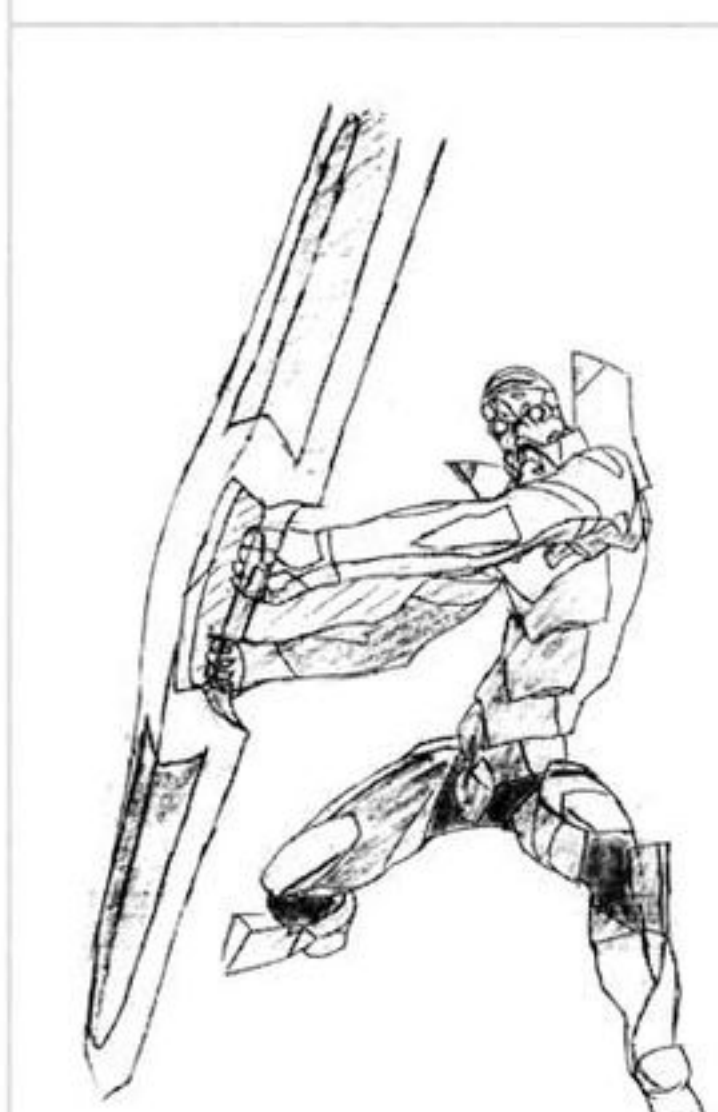

(4)



(2)



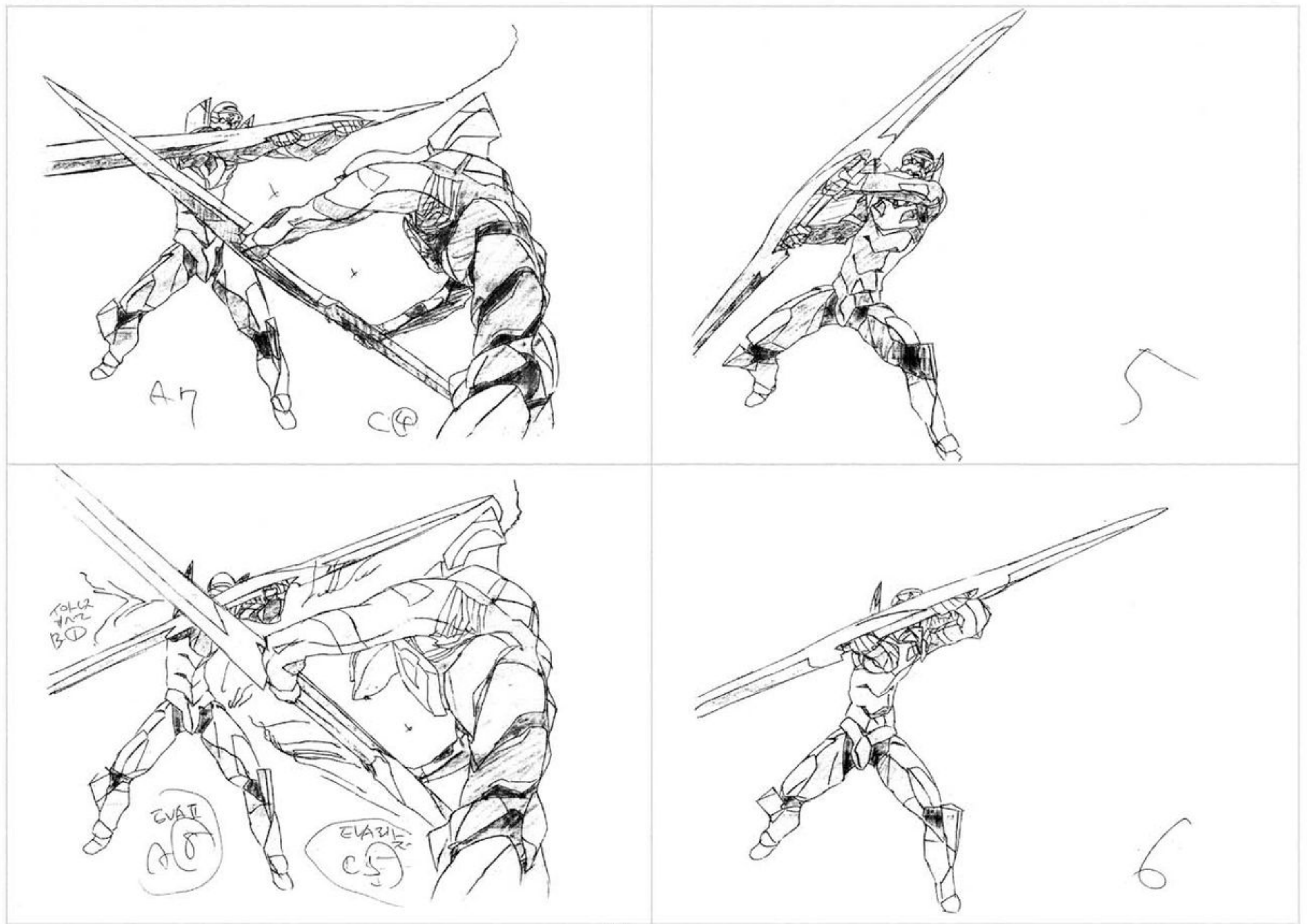



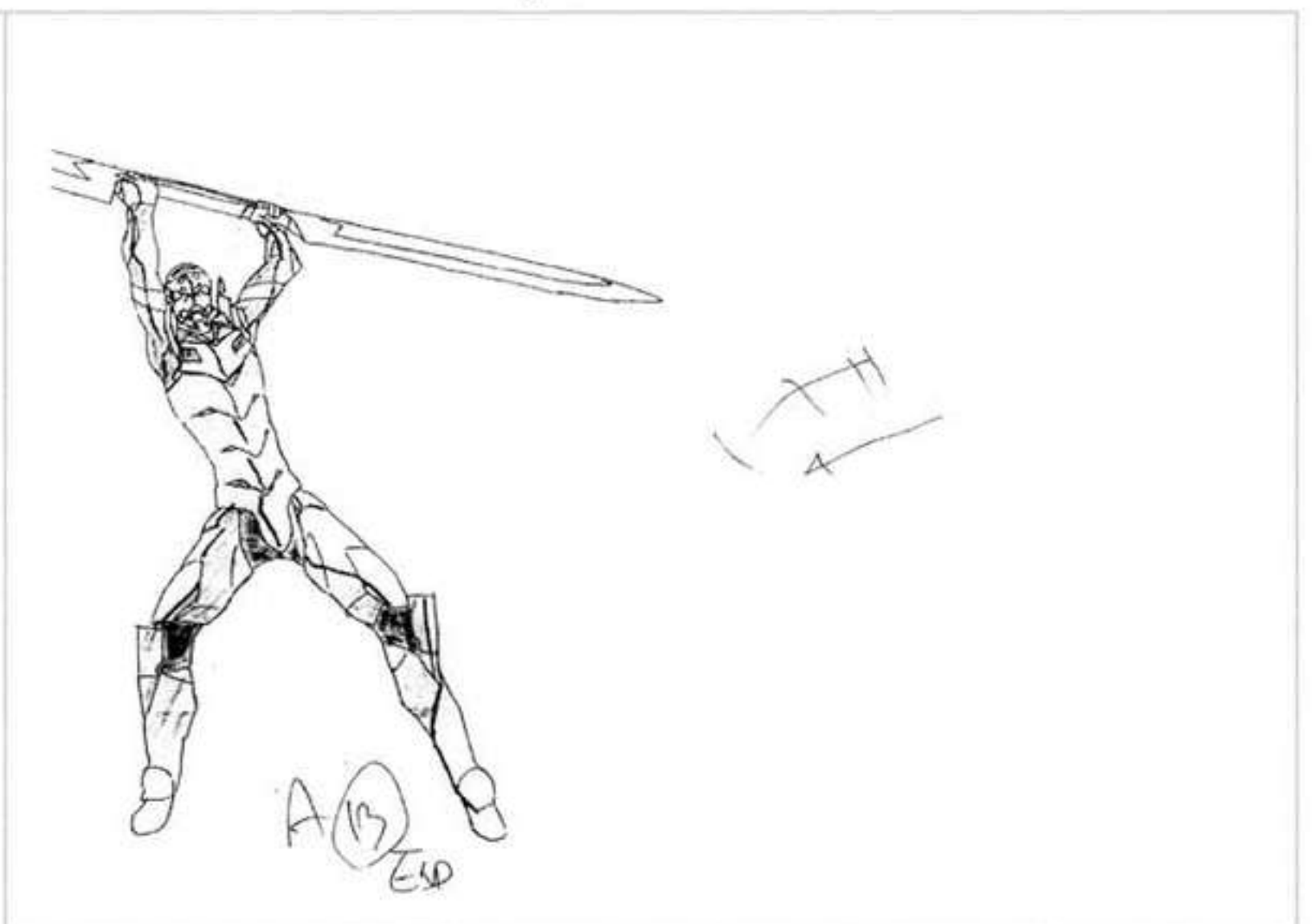
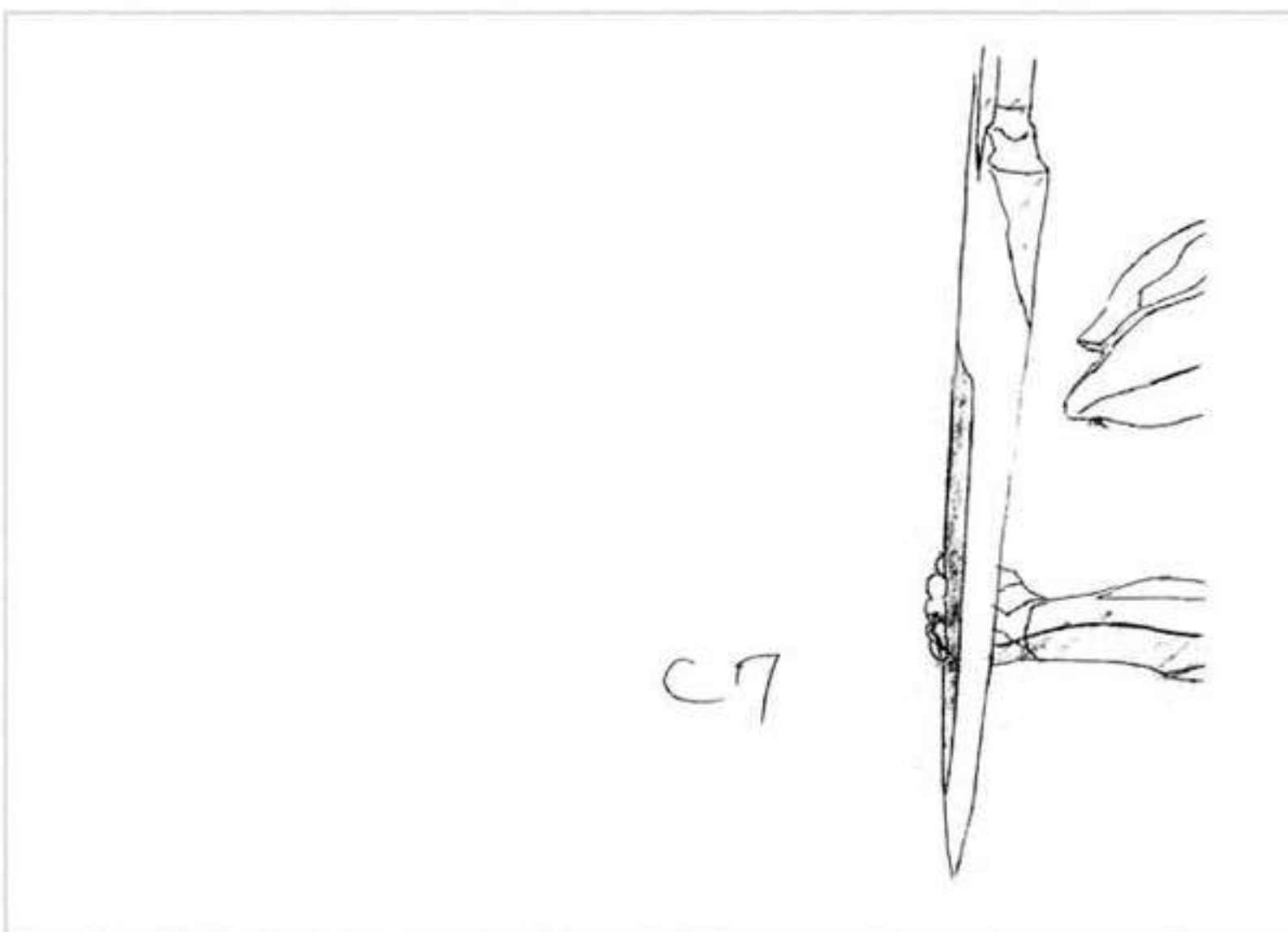
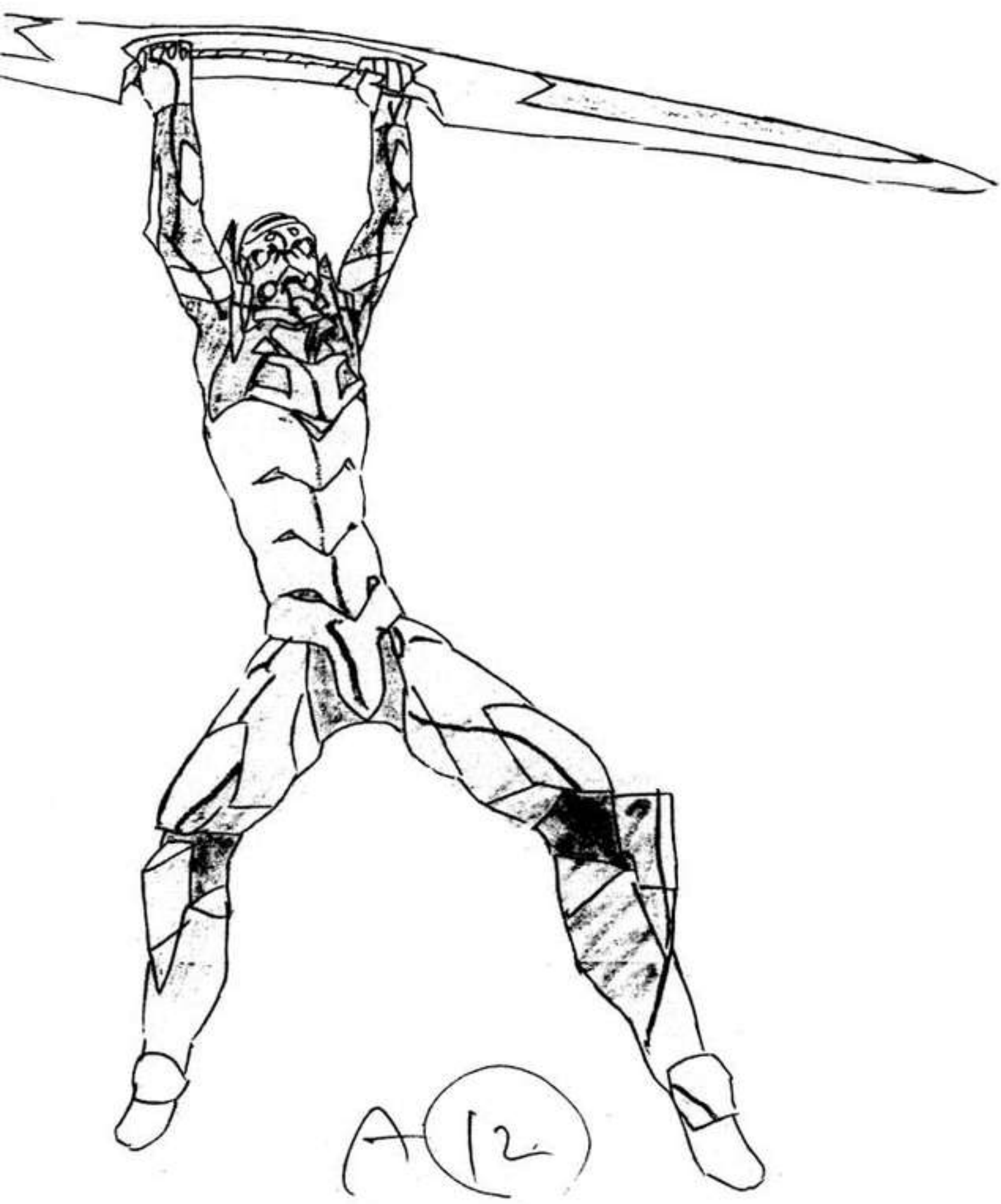
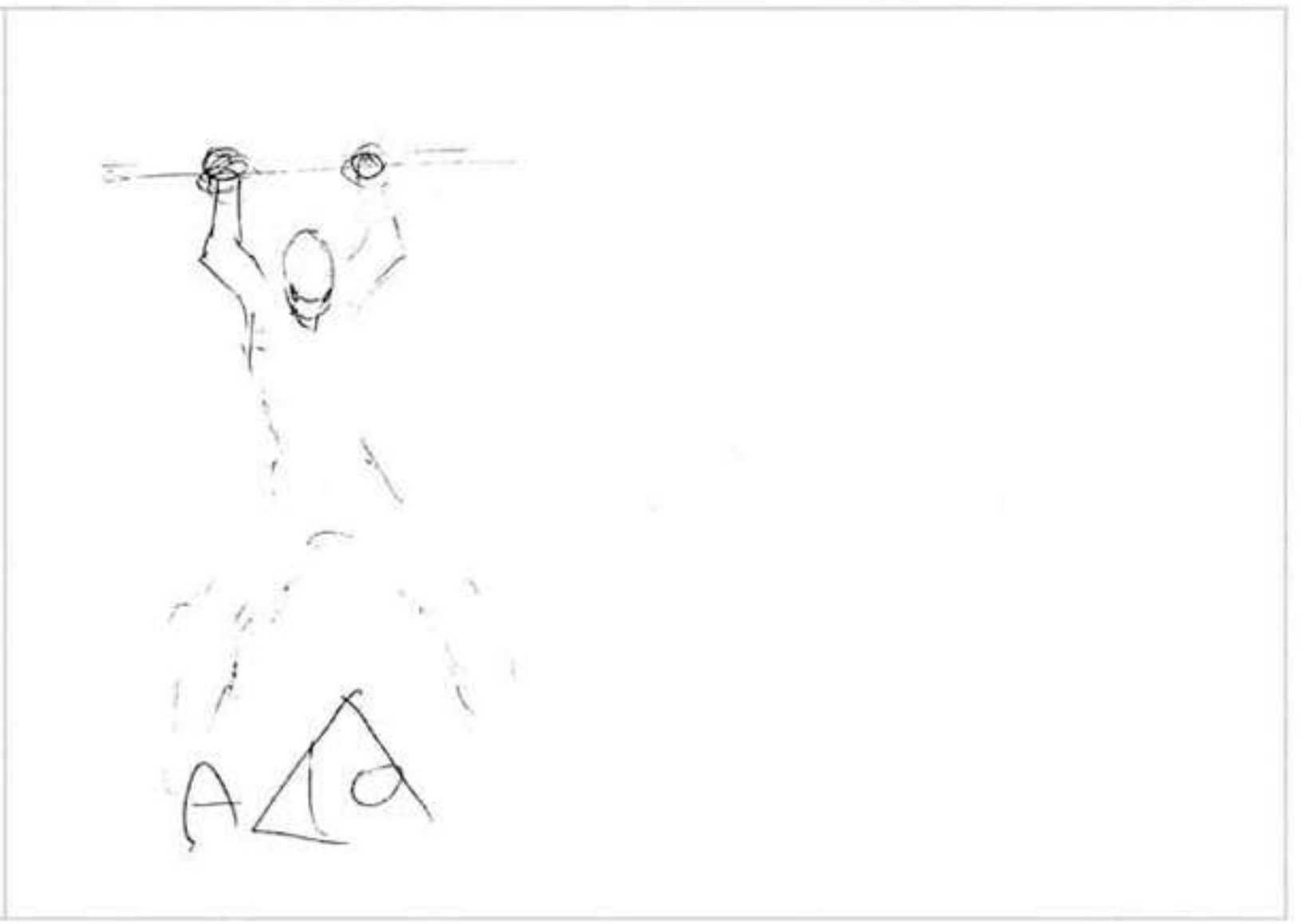
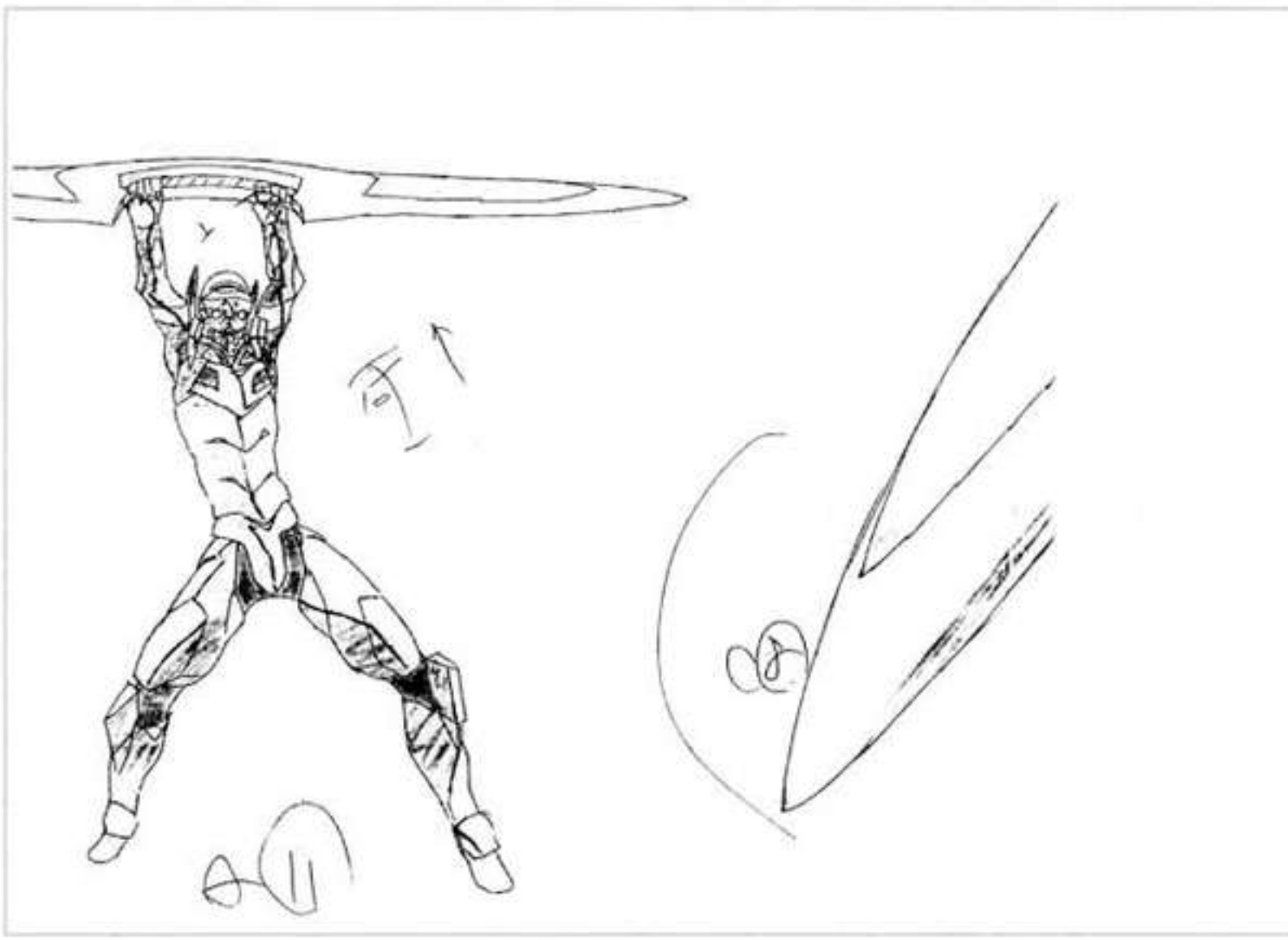



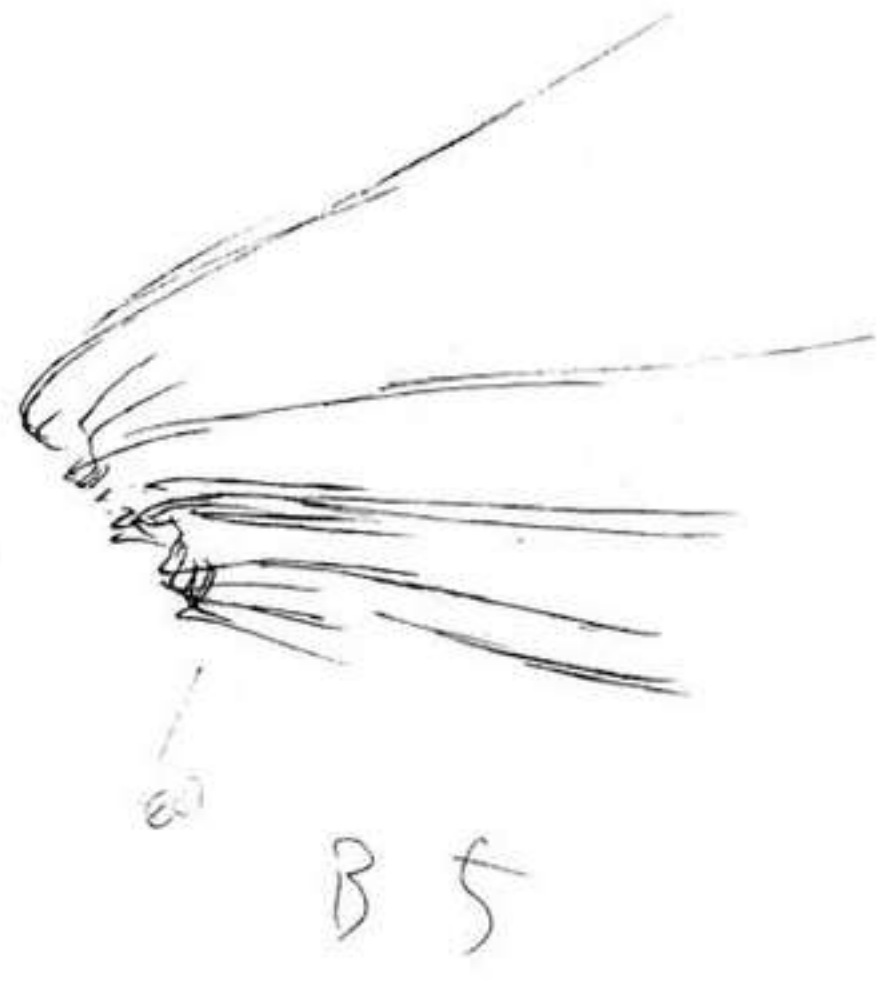

B 1

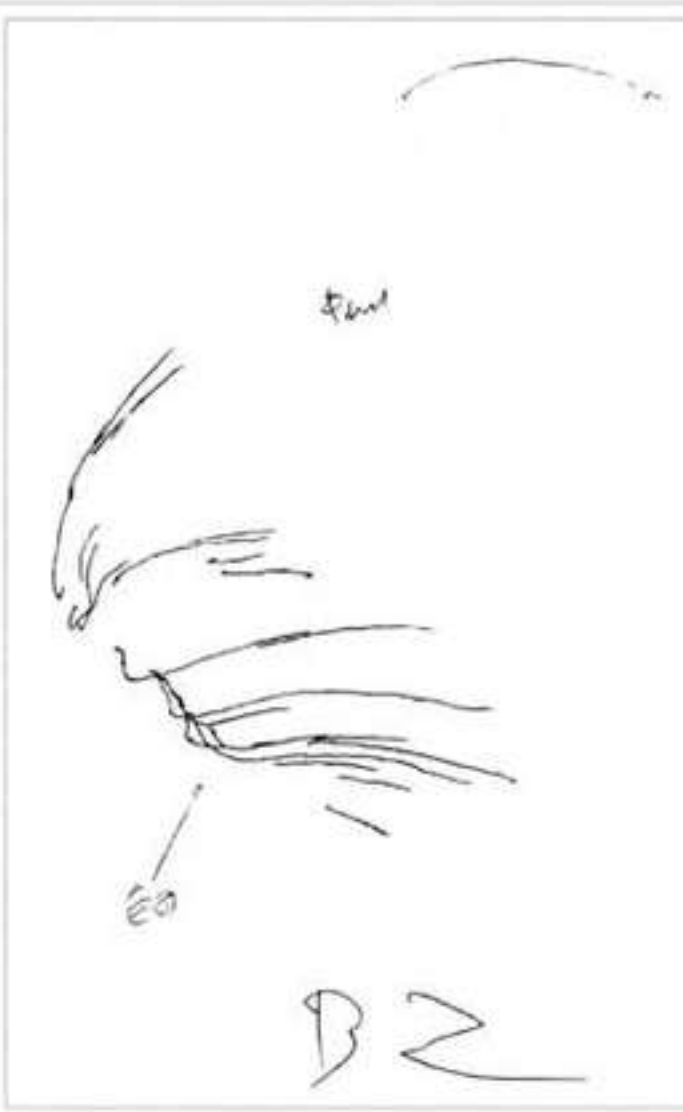
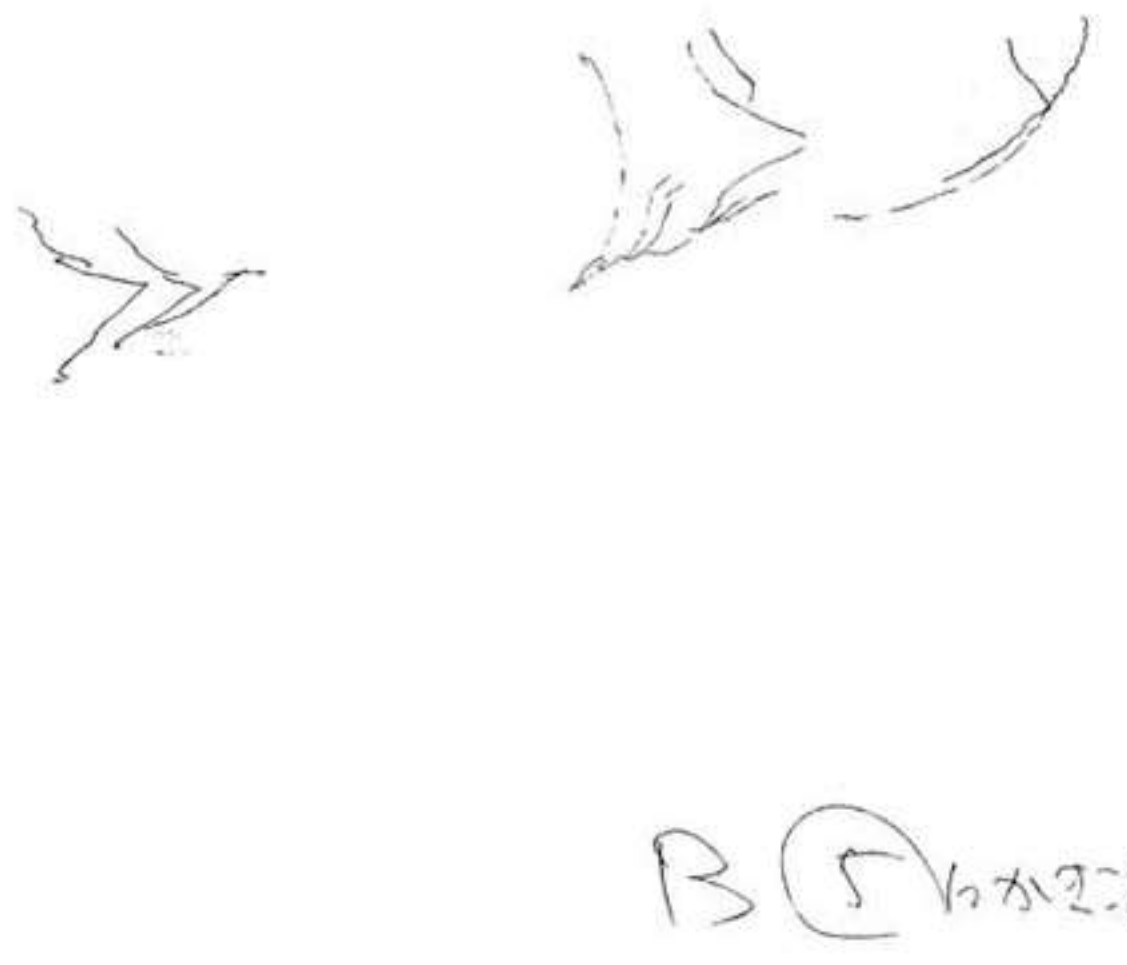

B 2

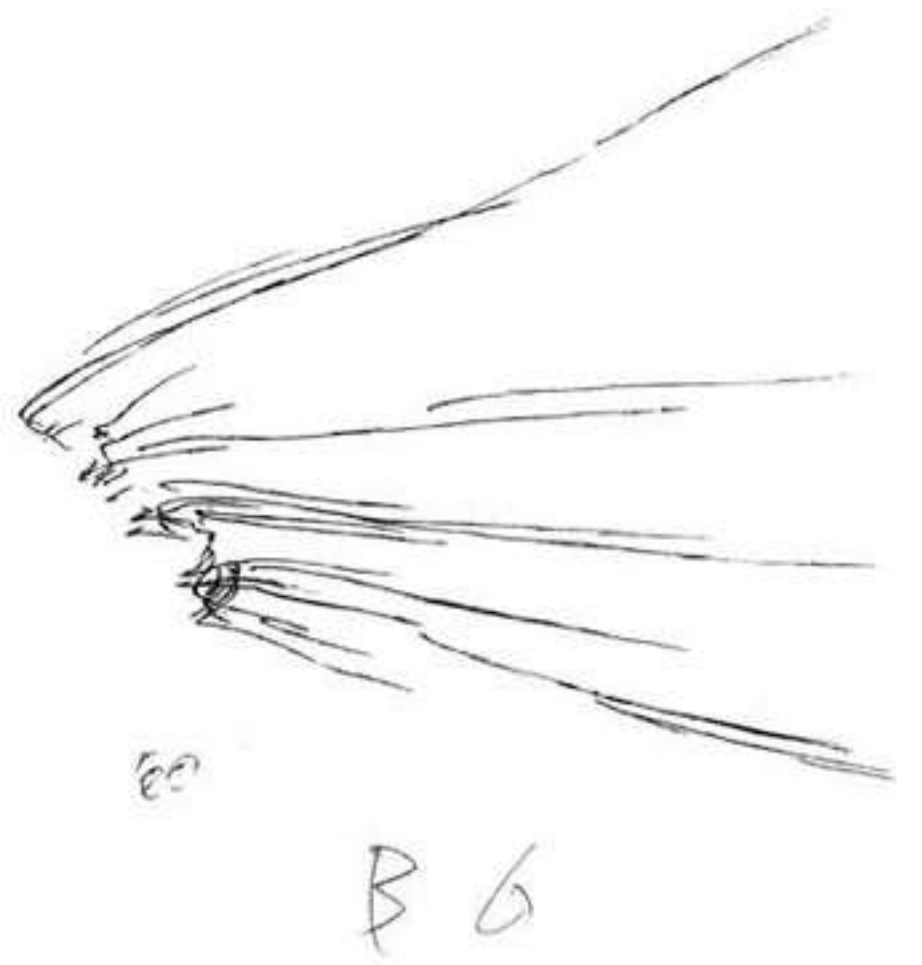
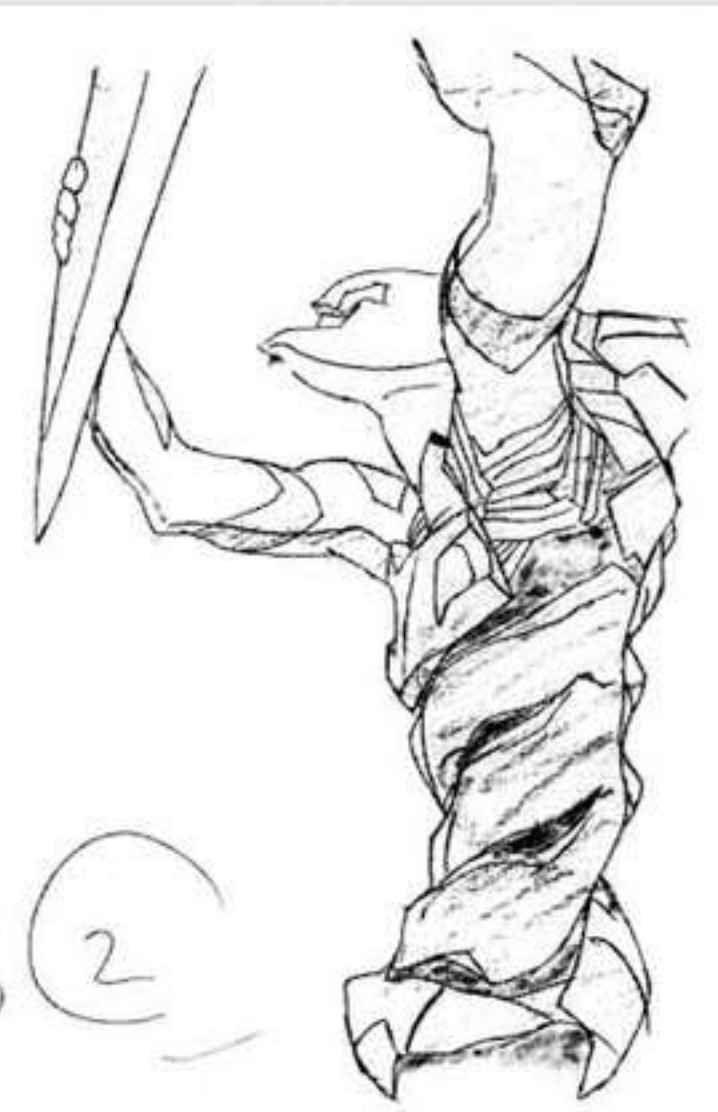

B 3

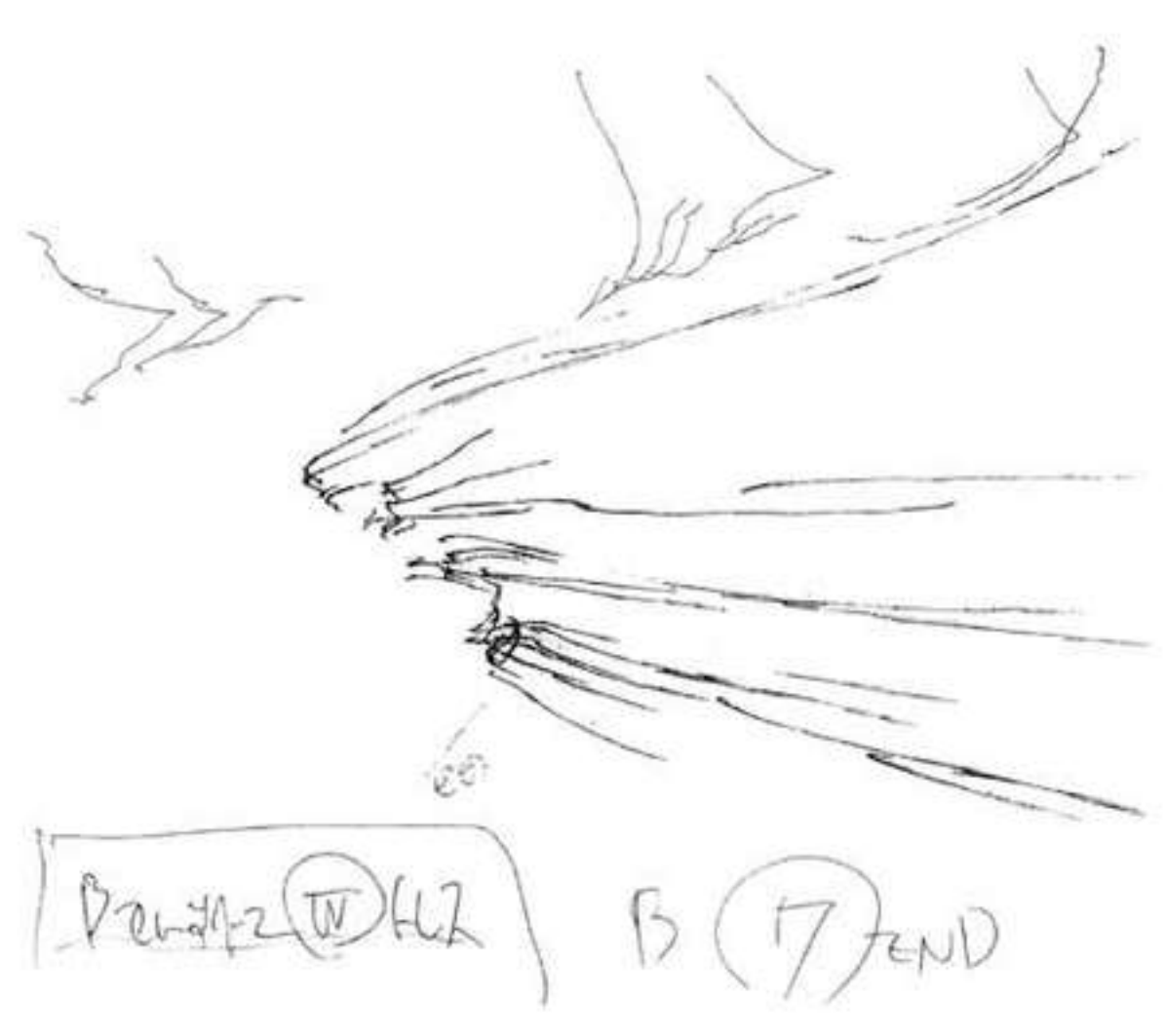
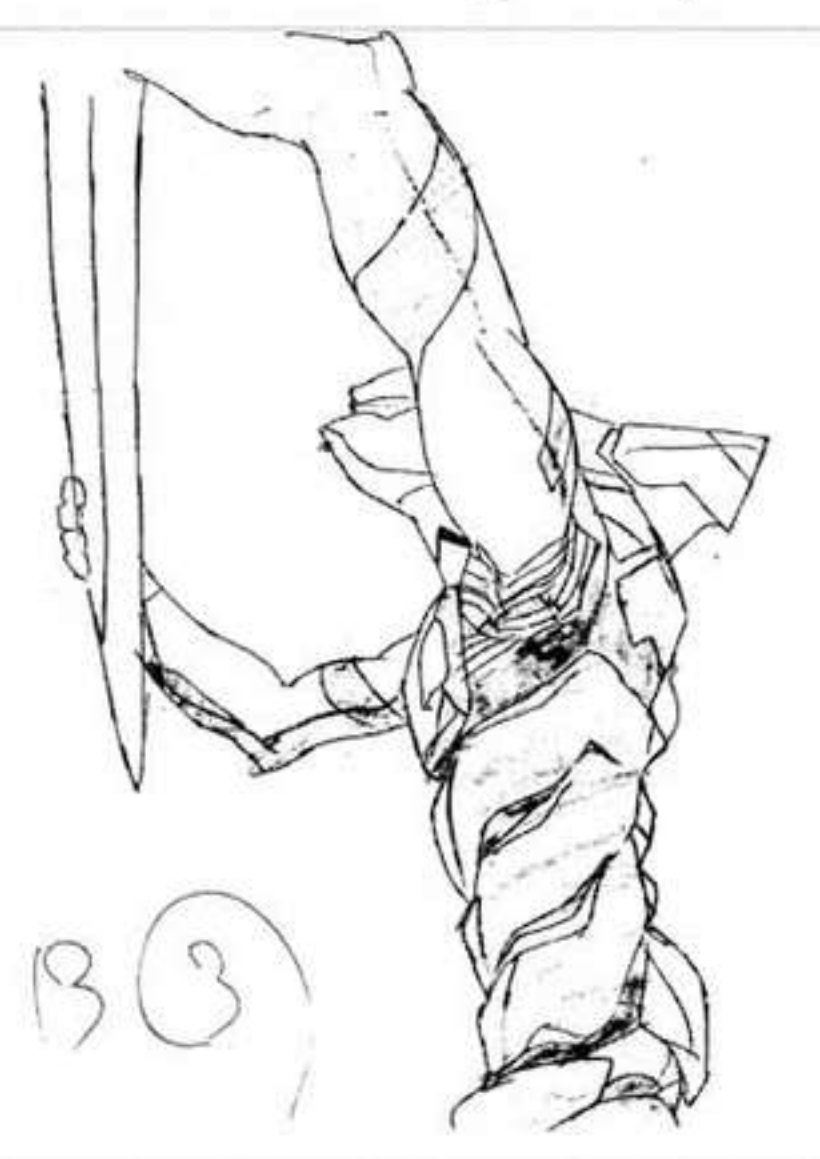

Pen-42 (W) FLZ

B 7 END

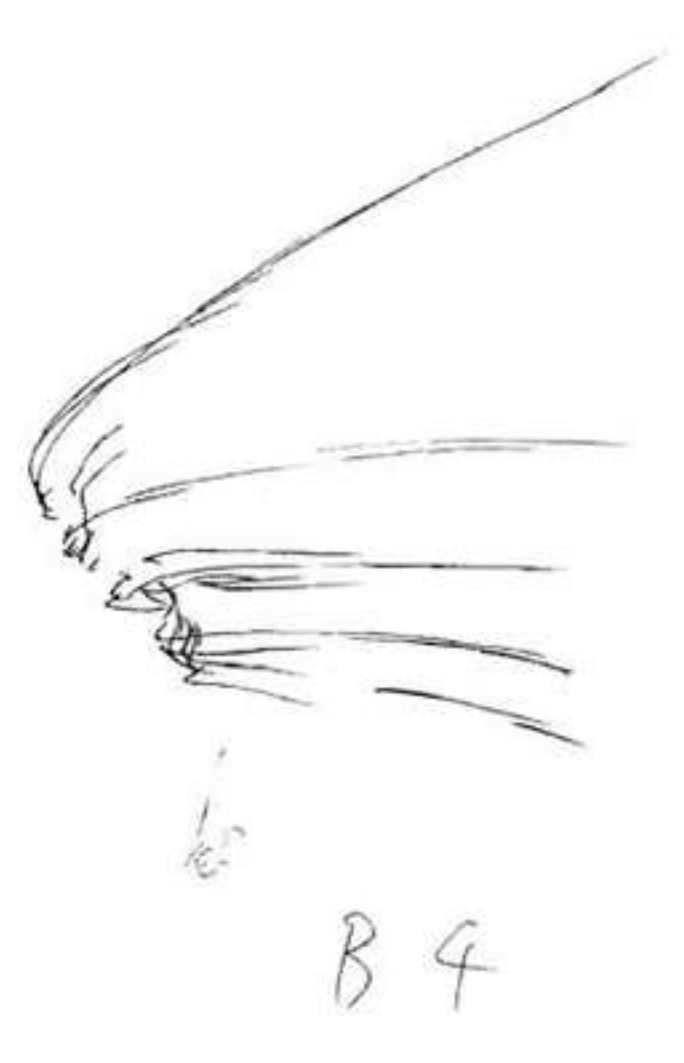

B 4



A	B	C	D	
1	X	X	X	2
1				4
1				6
2				8
1				10
3				12
1				14
4				16
1				18
5				20
1				22
6				24
7				26
8				28
9				30
10				32
11				34
12				36
13				38
14				40
15				42
16				44
17				46
18				48
19				50
20				52

タイムシート



D4

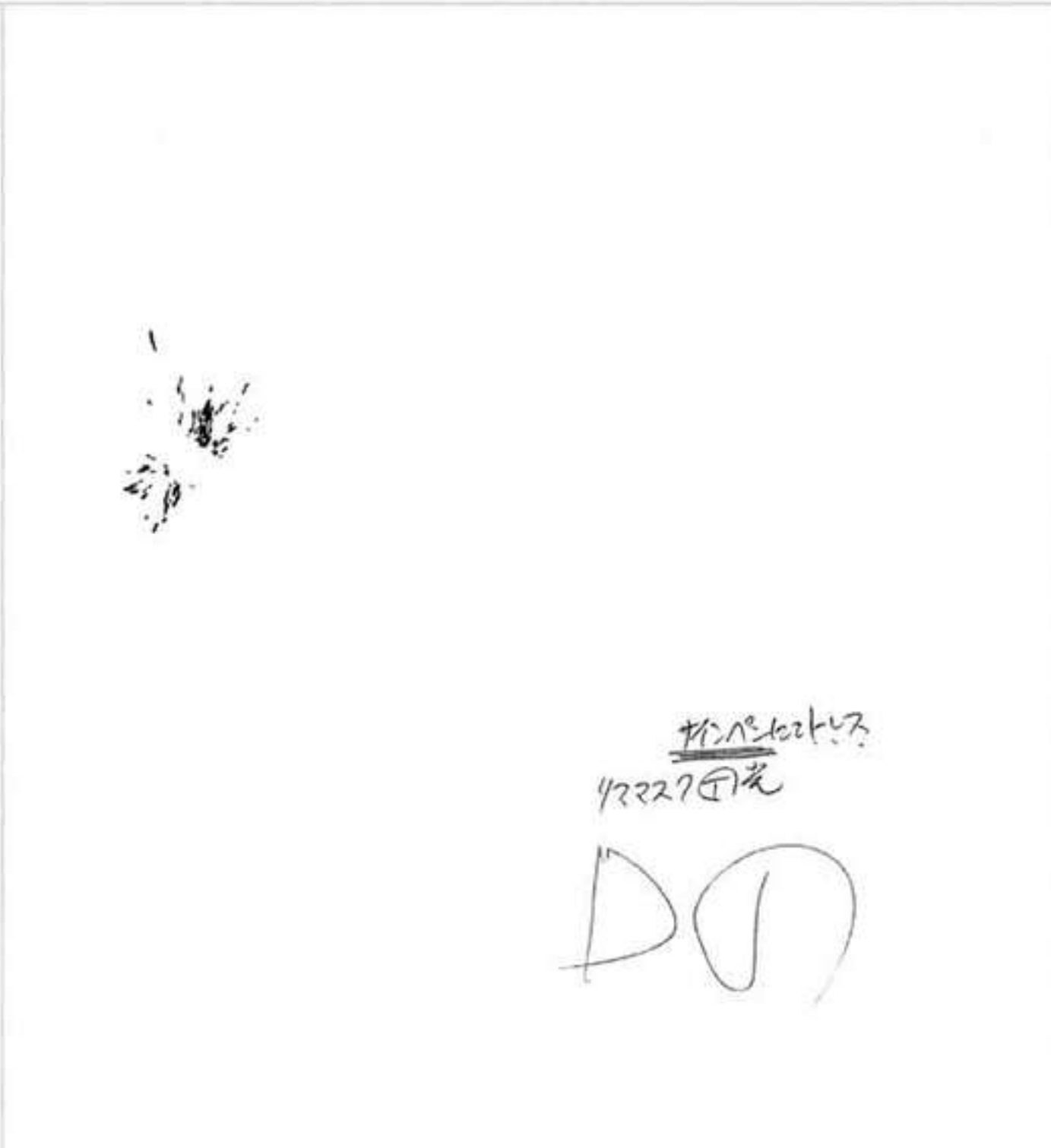

42227  
花  
D0



D5



D2

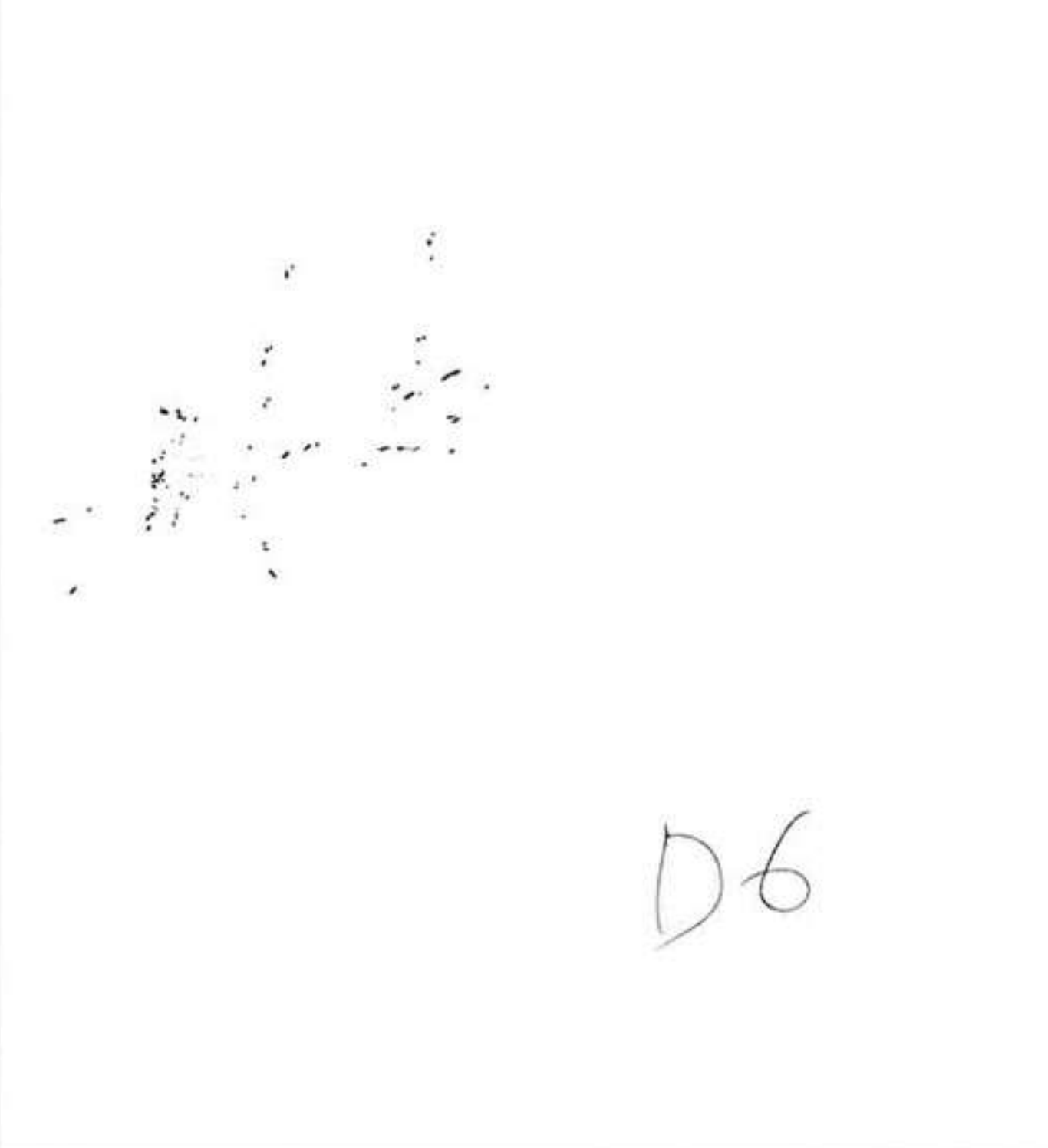

D6



A3



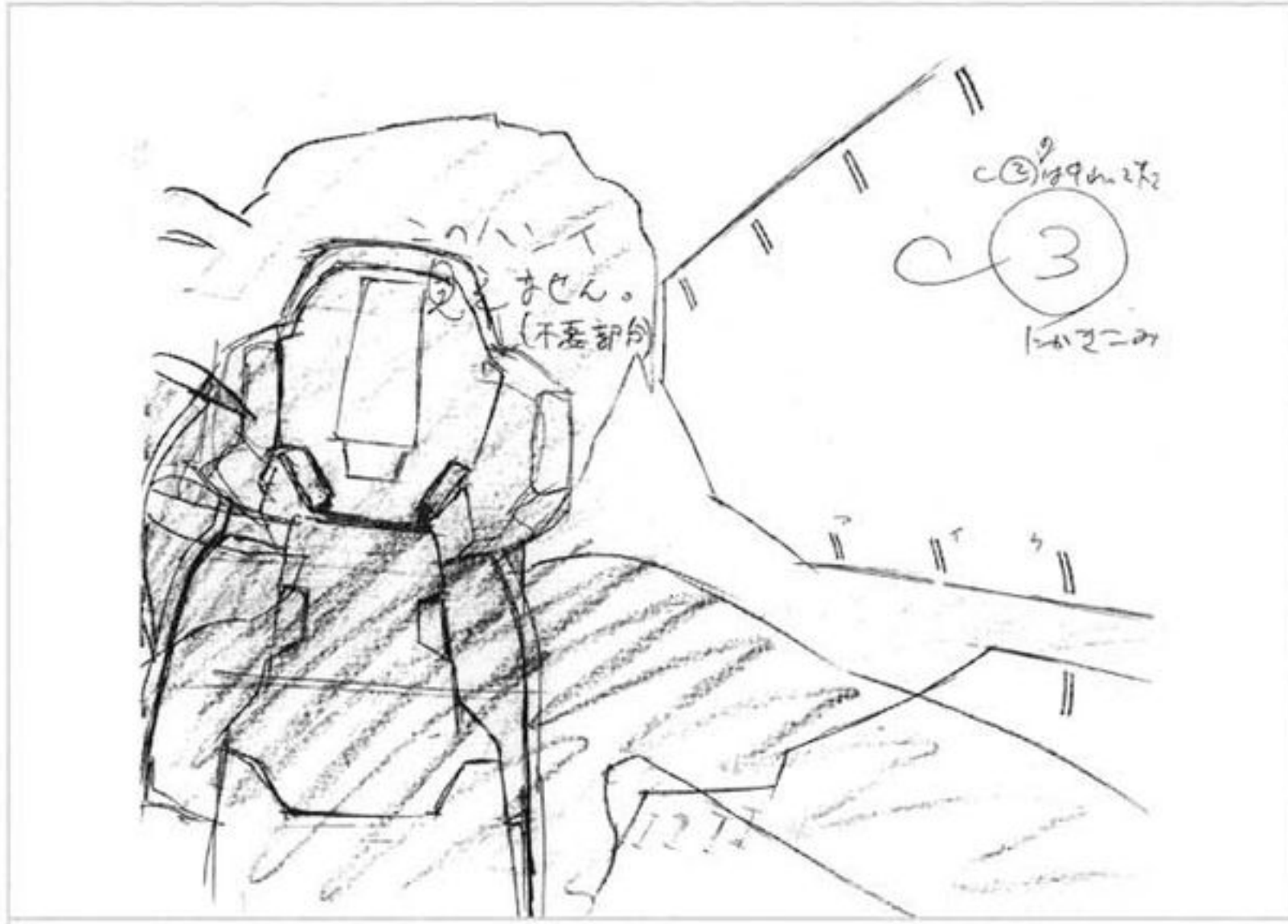

#25-C455

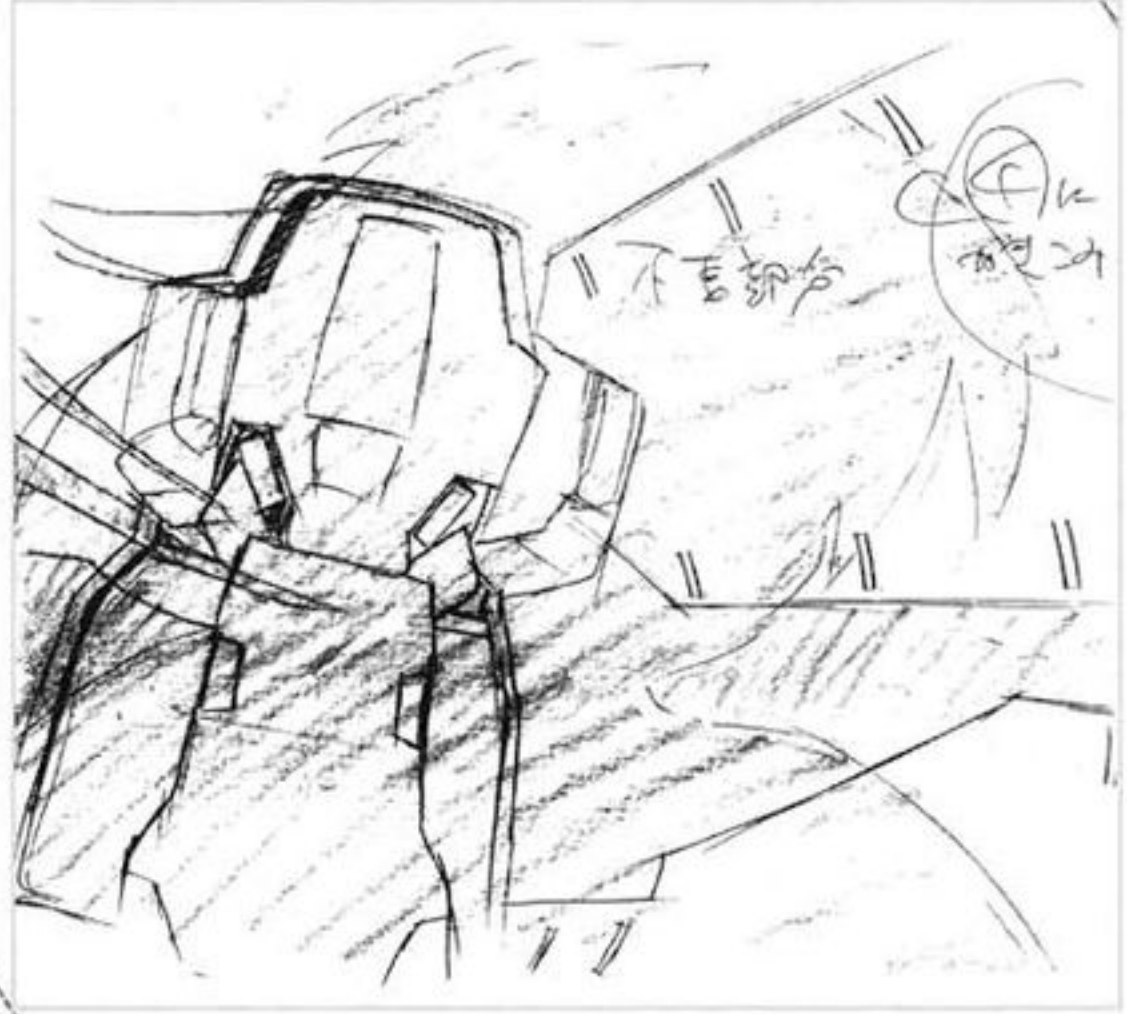



#25-C457

8m

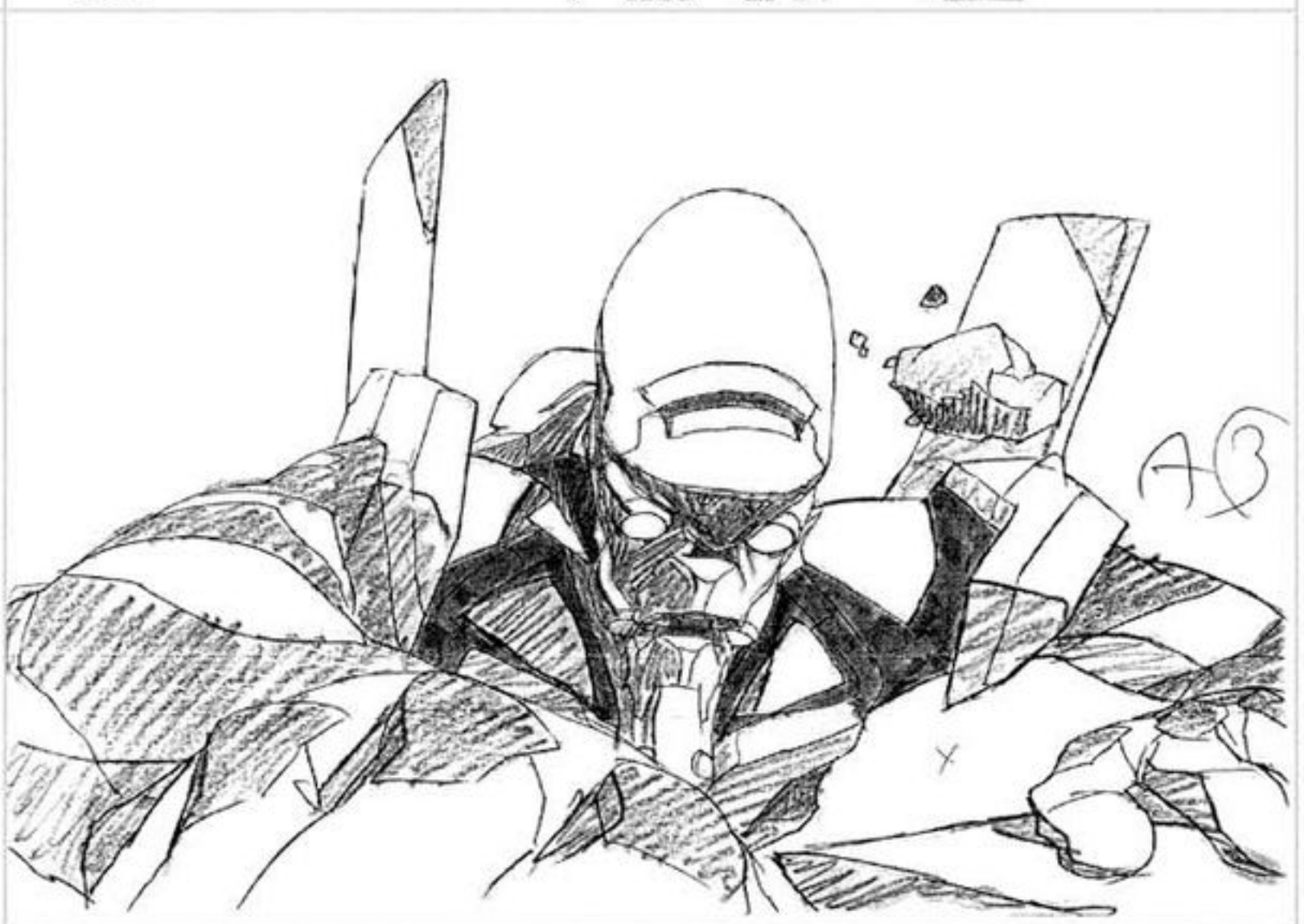
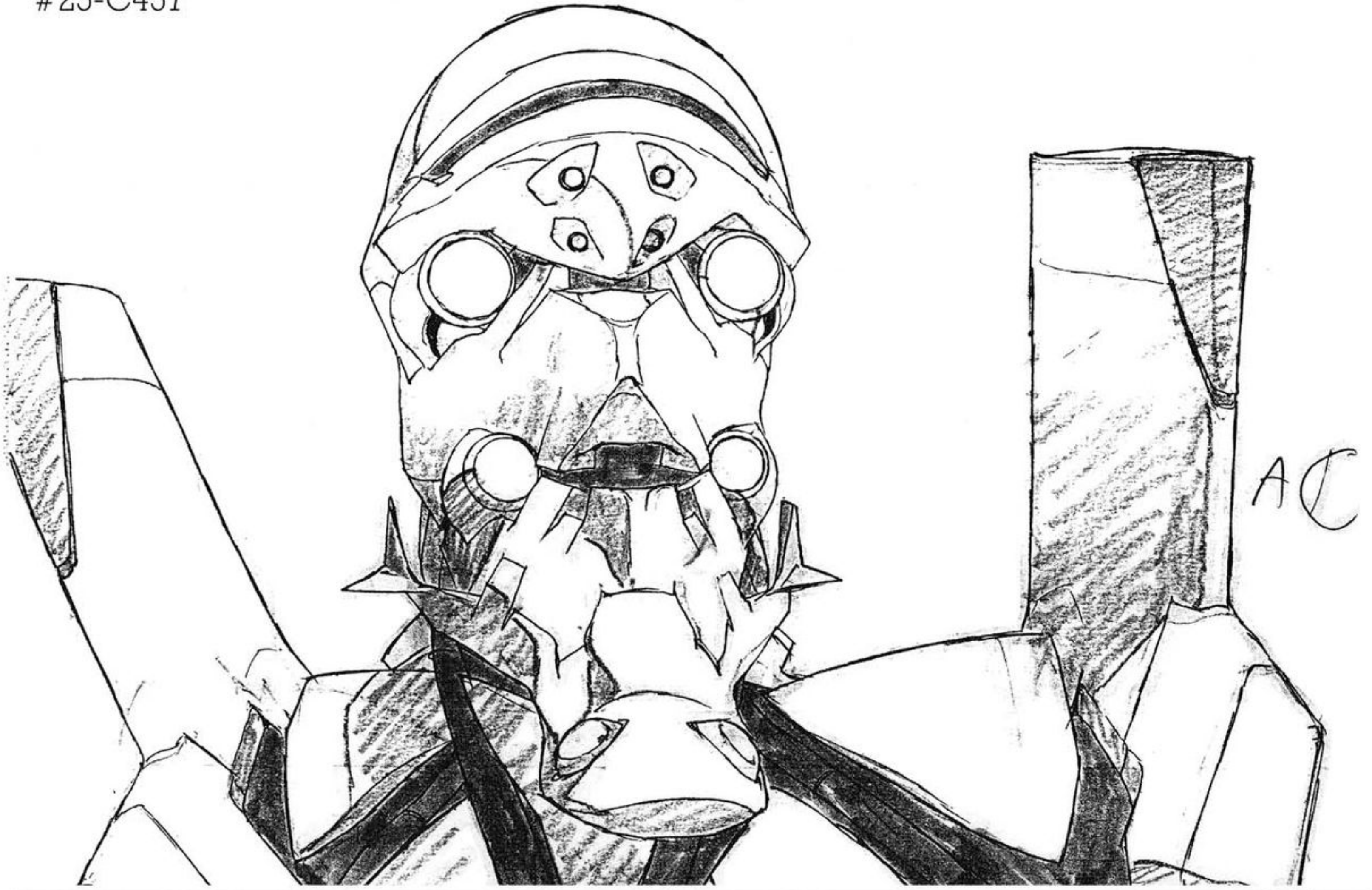



A7

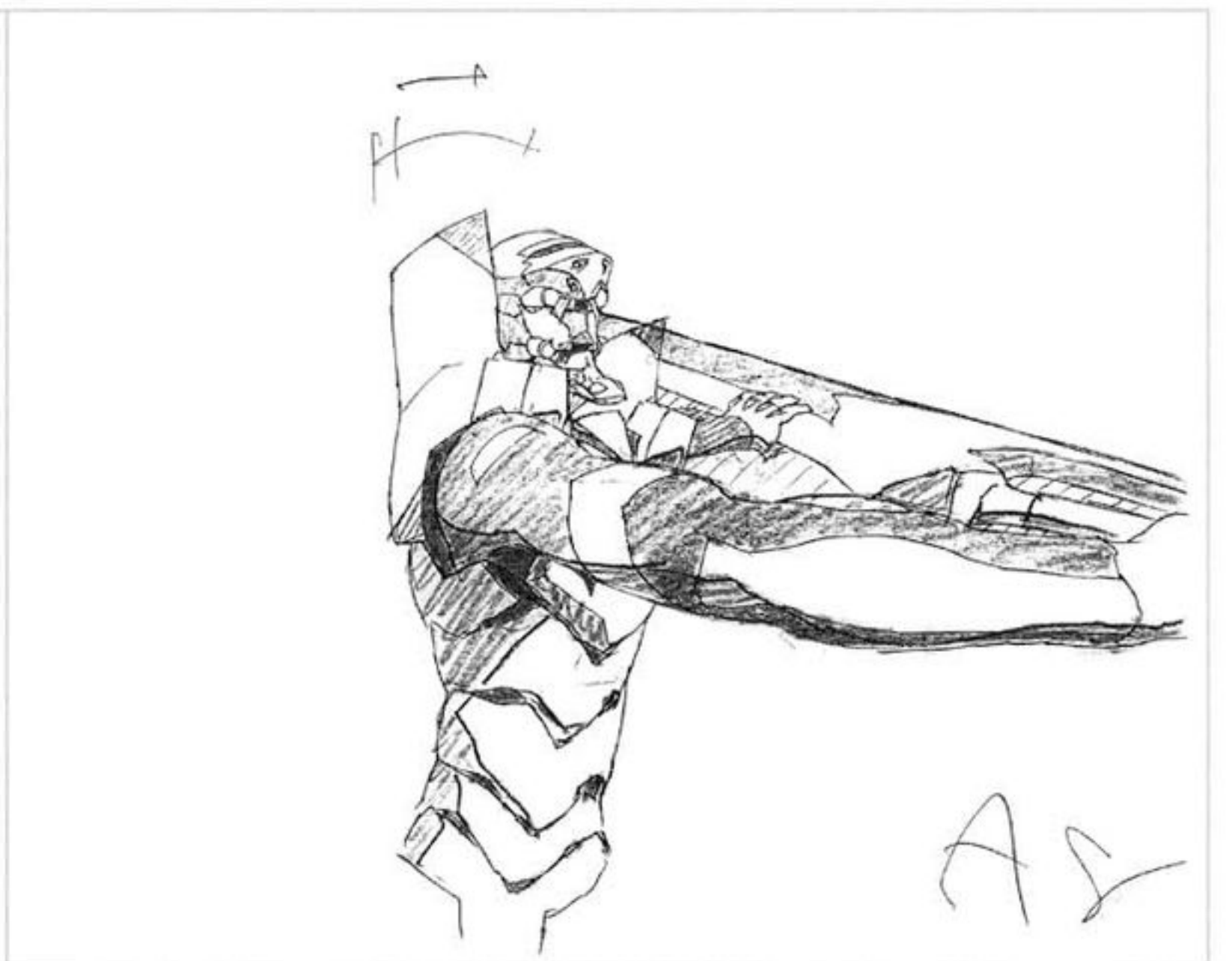
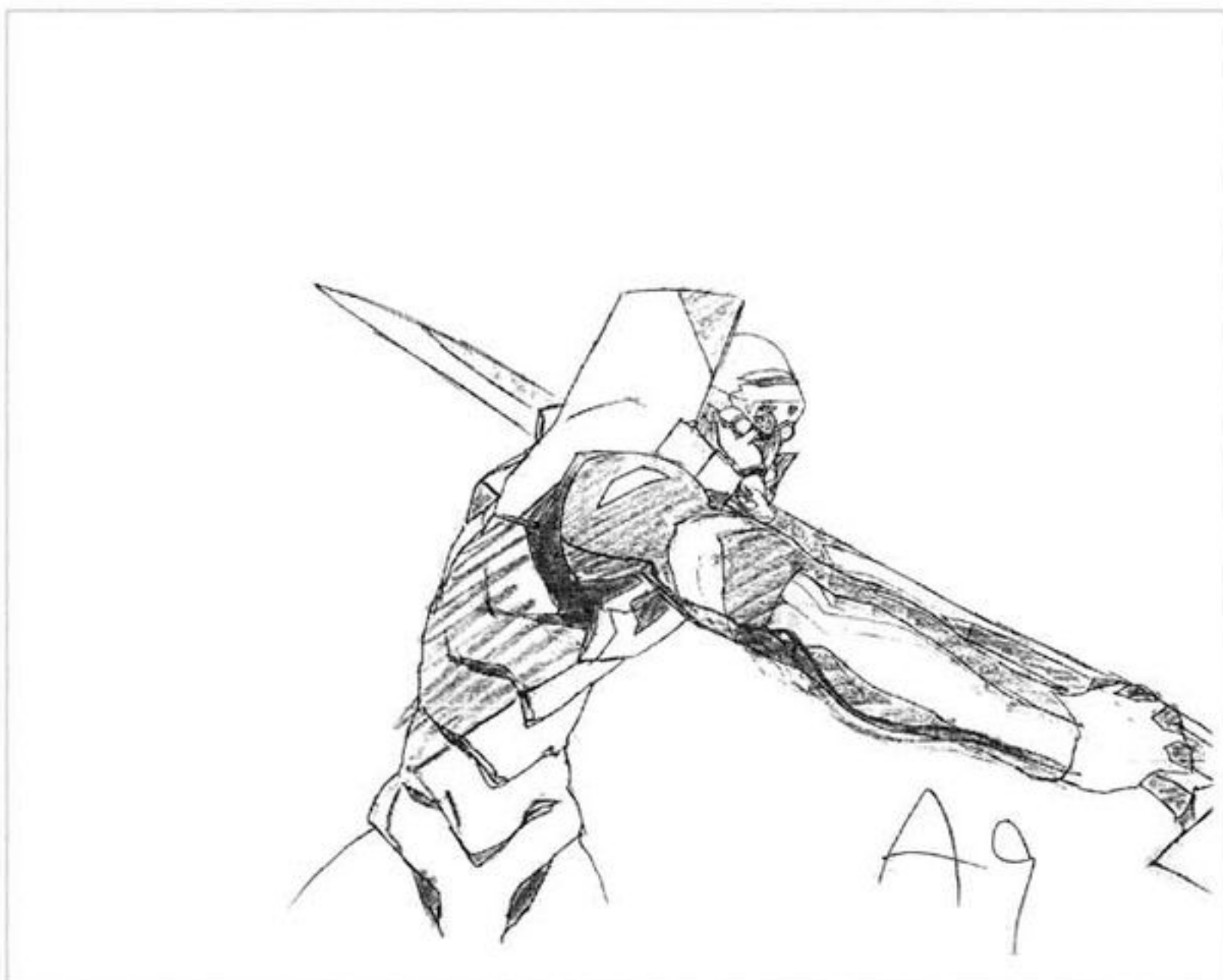
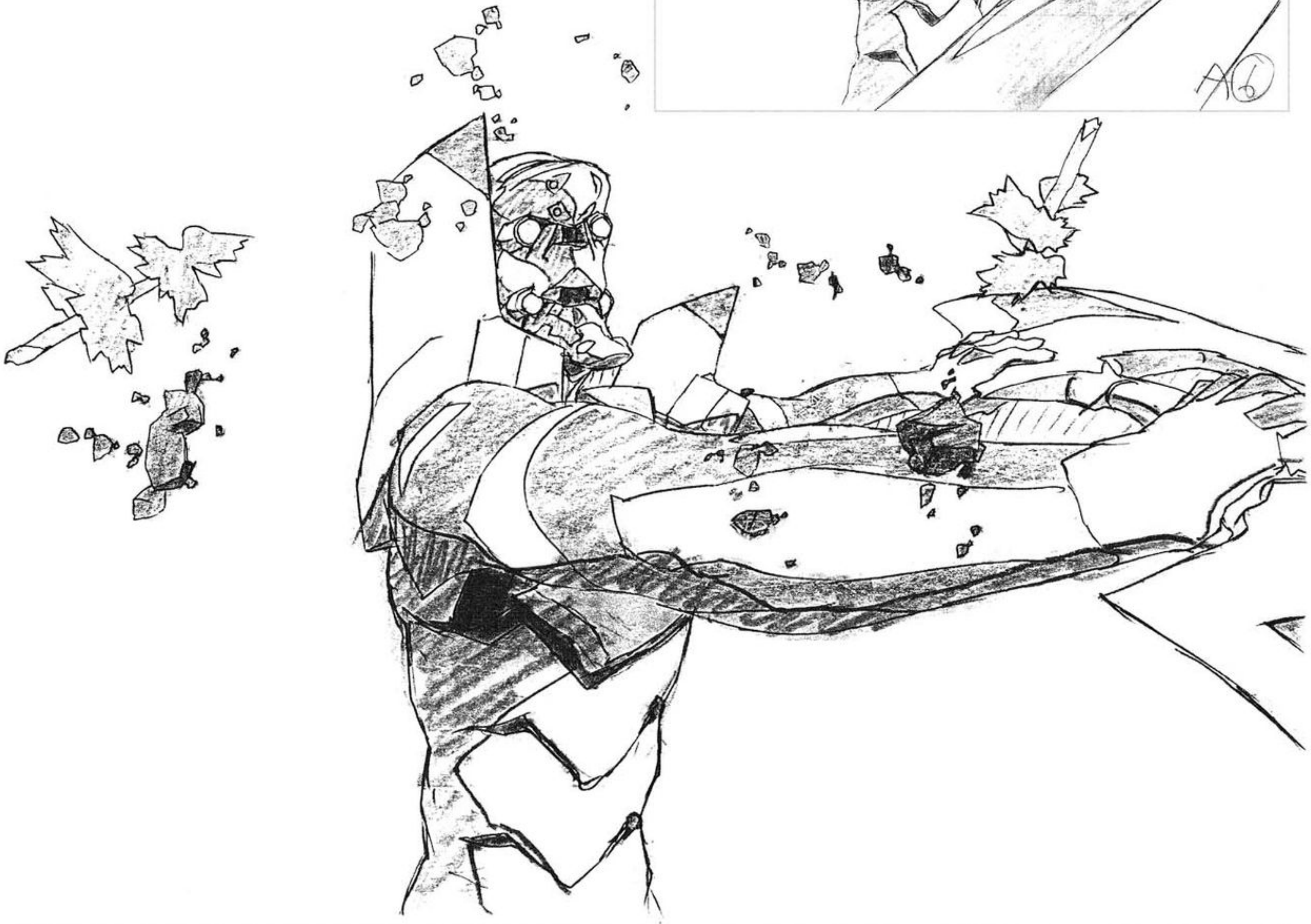



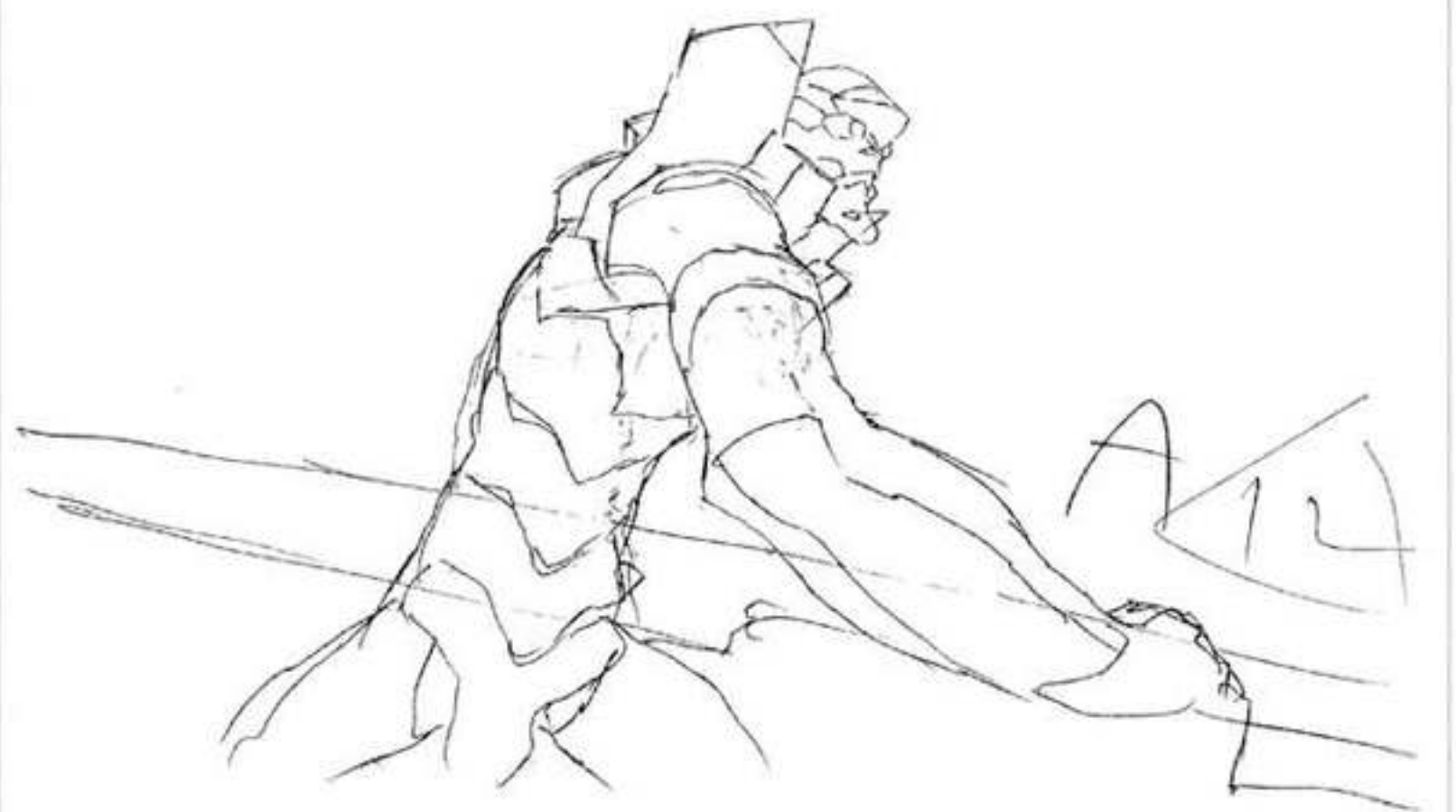
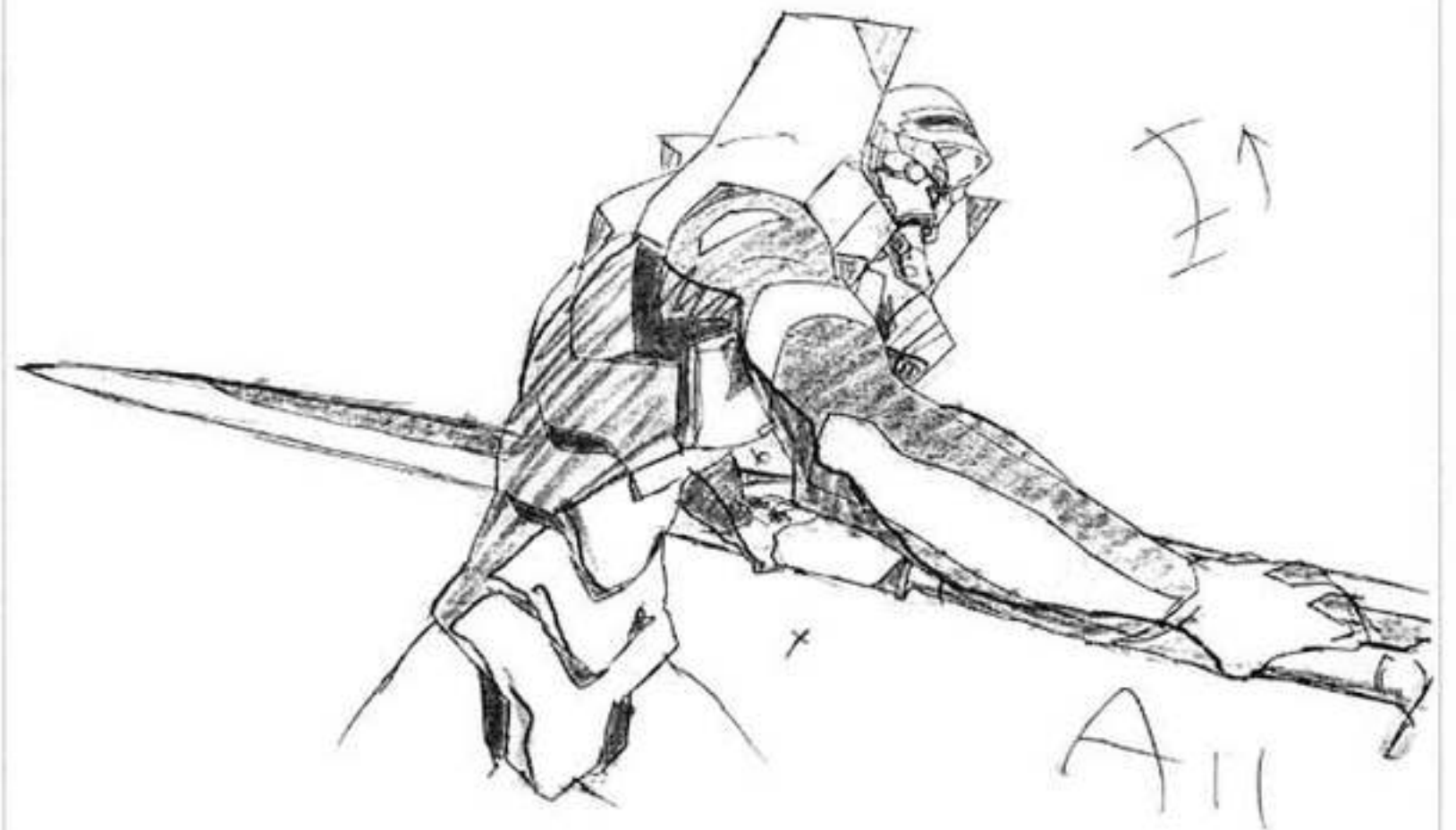
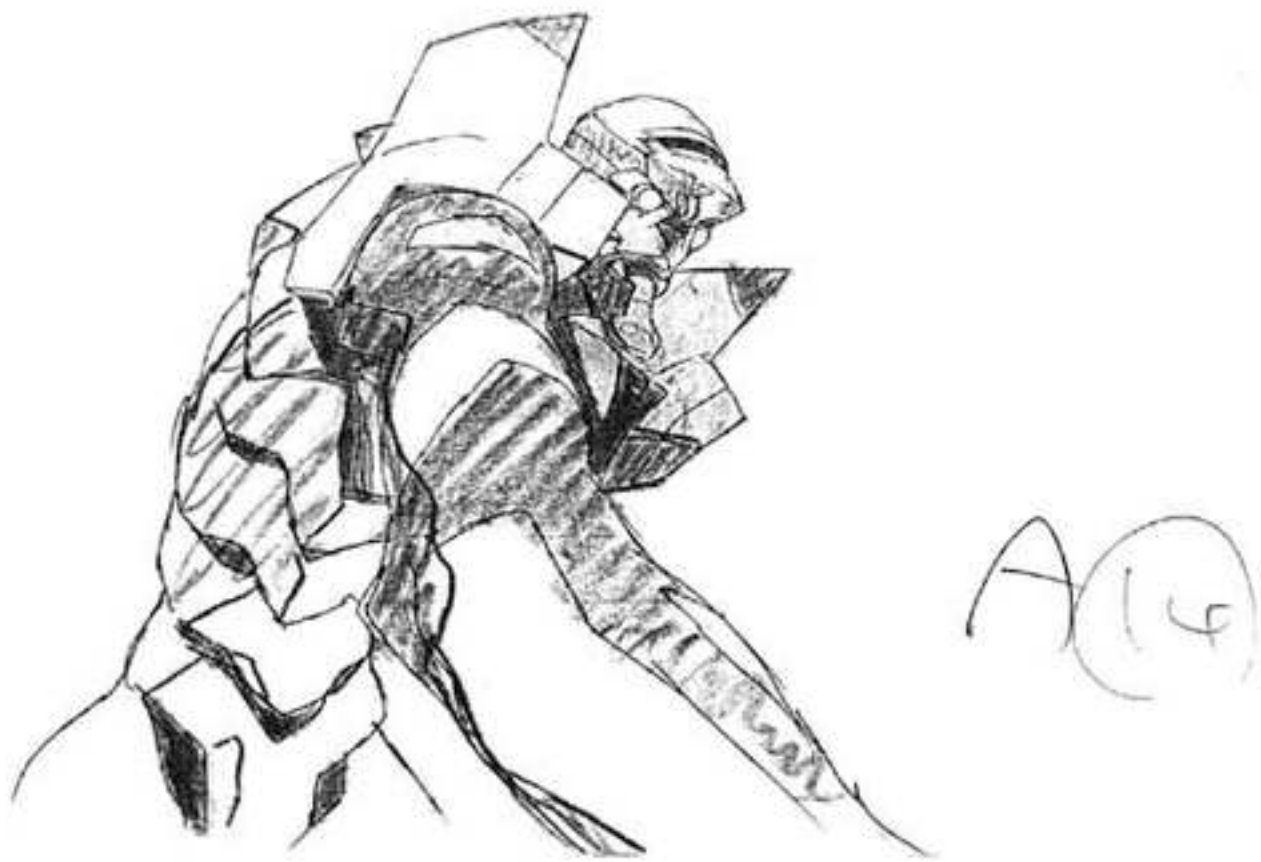



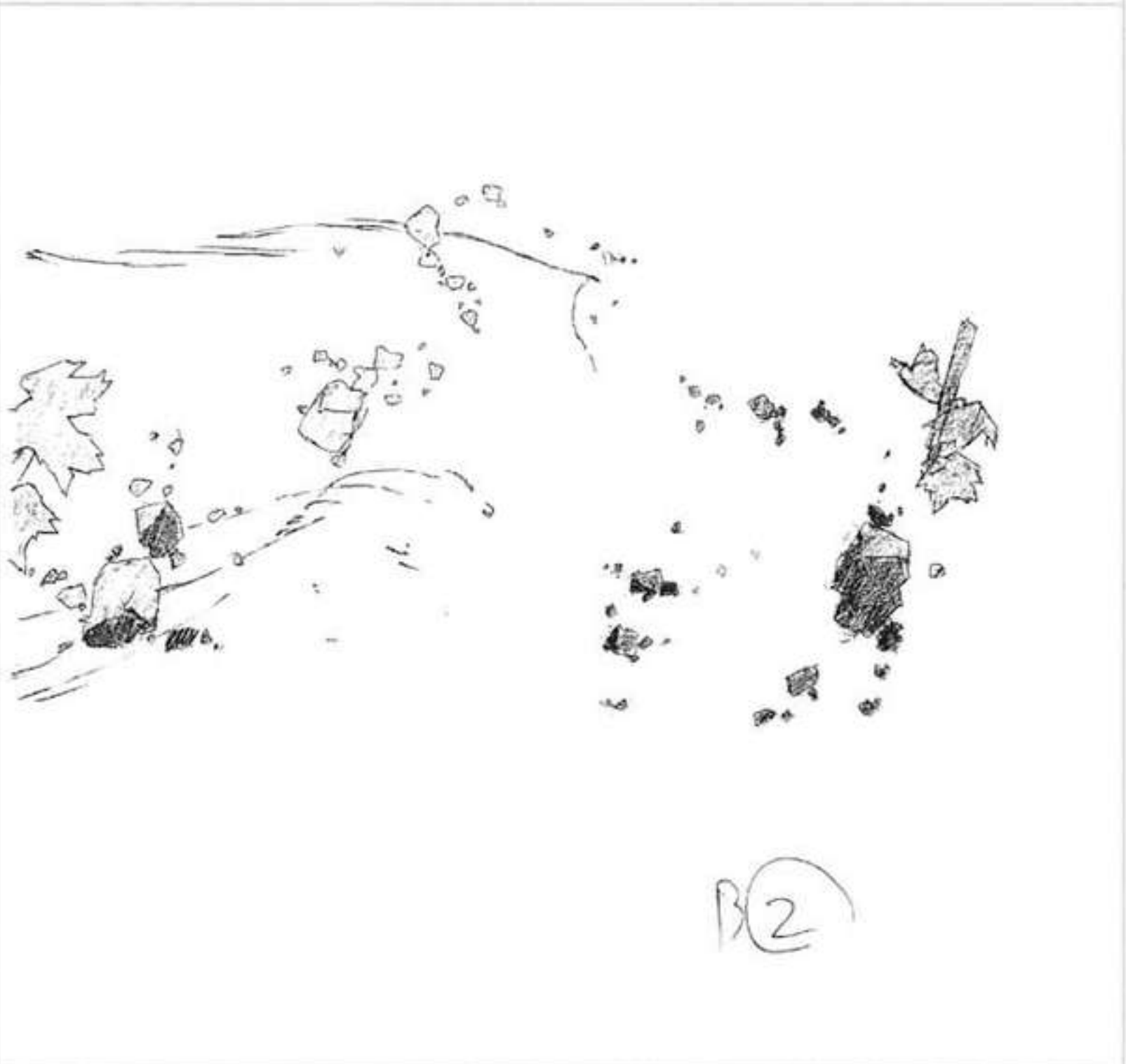
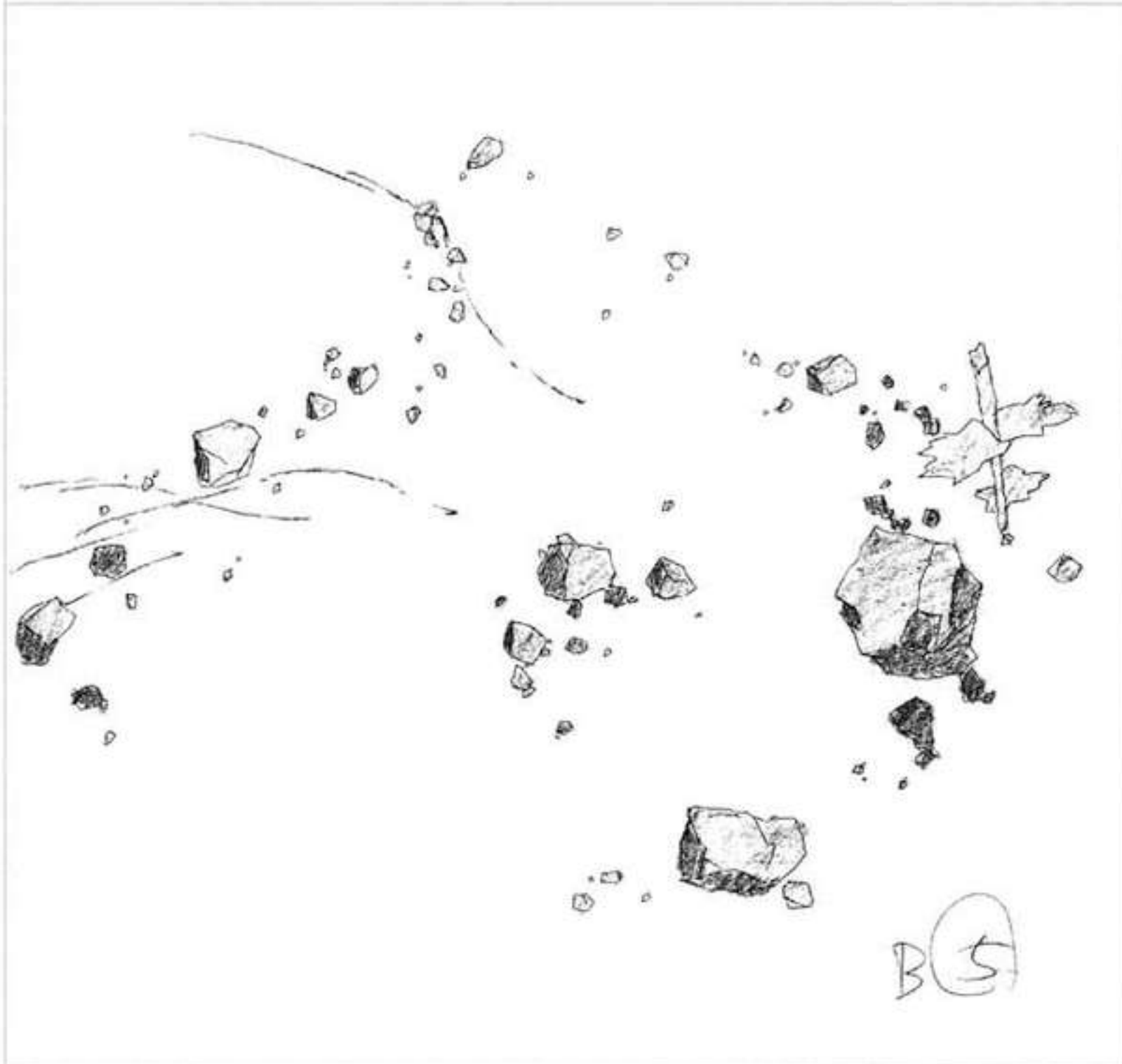



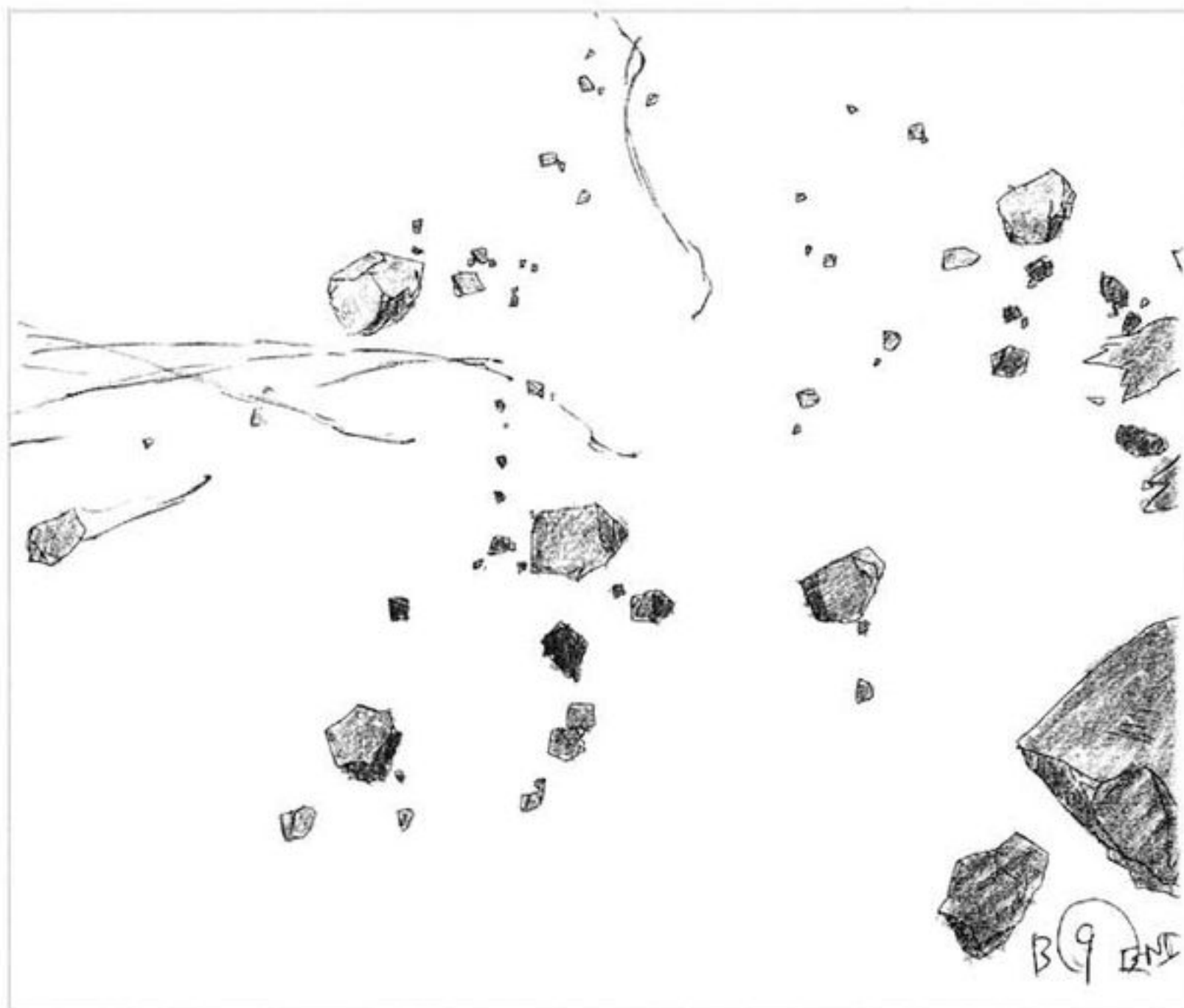

AB		
0	X	2
1		4
2		6
3		8
4		10
5		12
6		14
7		16
8	(1)	18
9	1	20
10	2	22
11	1	24
12	3	26
13	1	28
14	4	30
15	5	32
16	6	34
17	1	36
18	7	38
19	1	40
20	8	42
21	9	44
22		46
23		48

#25-C457  
タイムシート

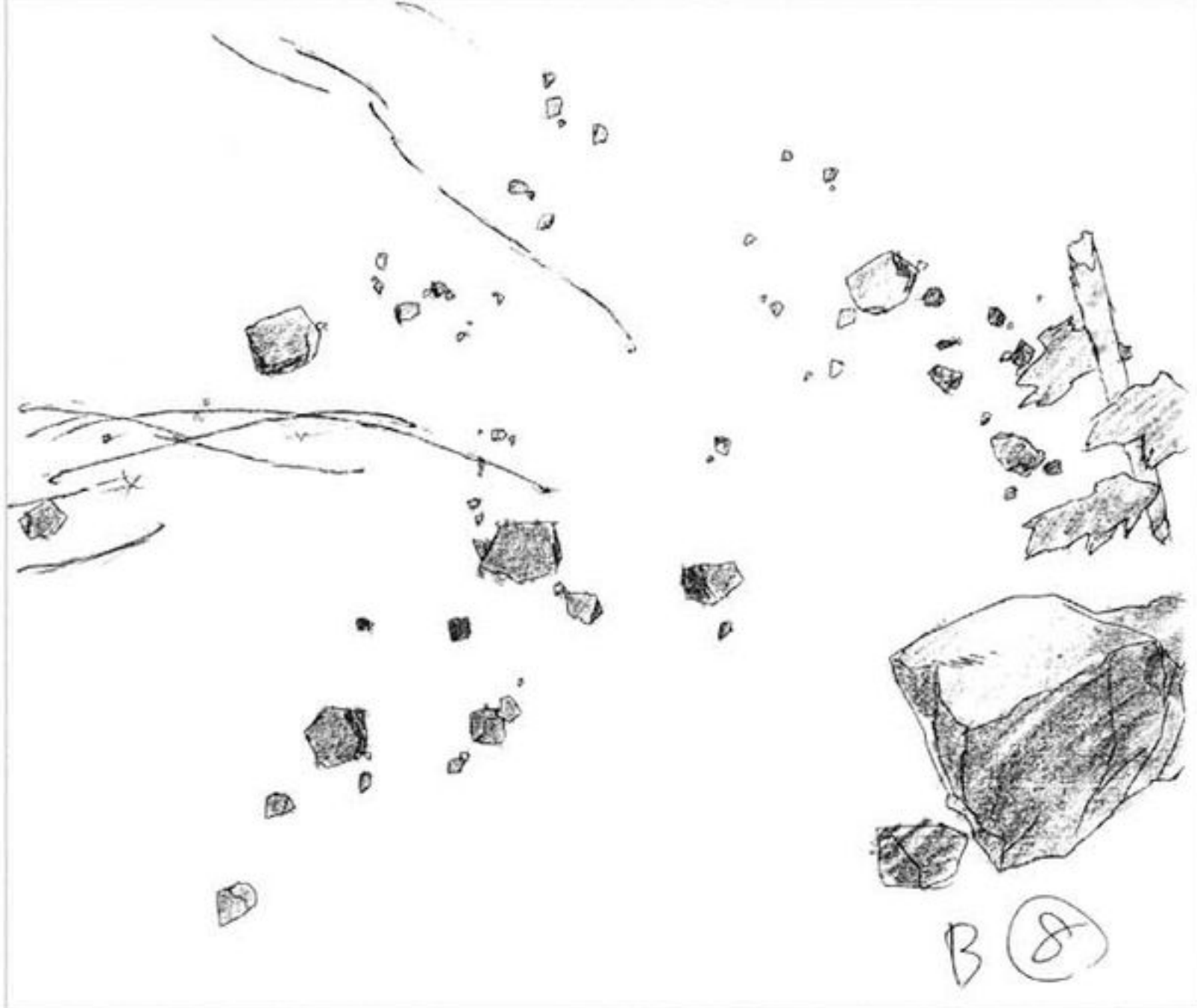

#25-C457 レイアウト

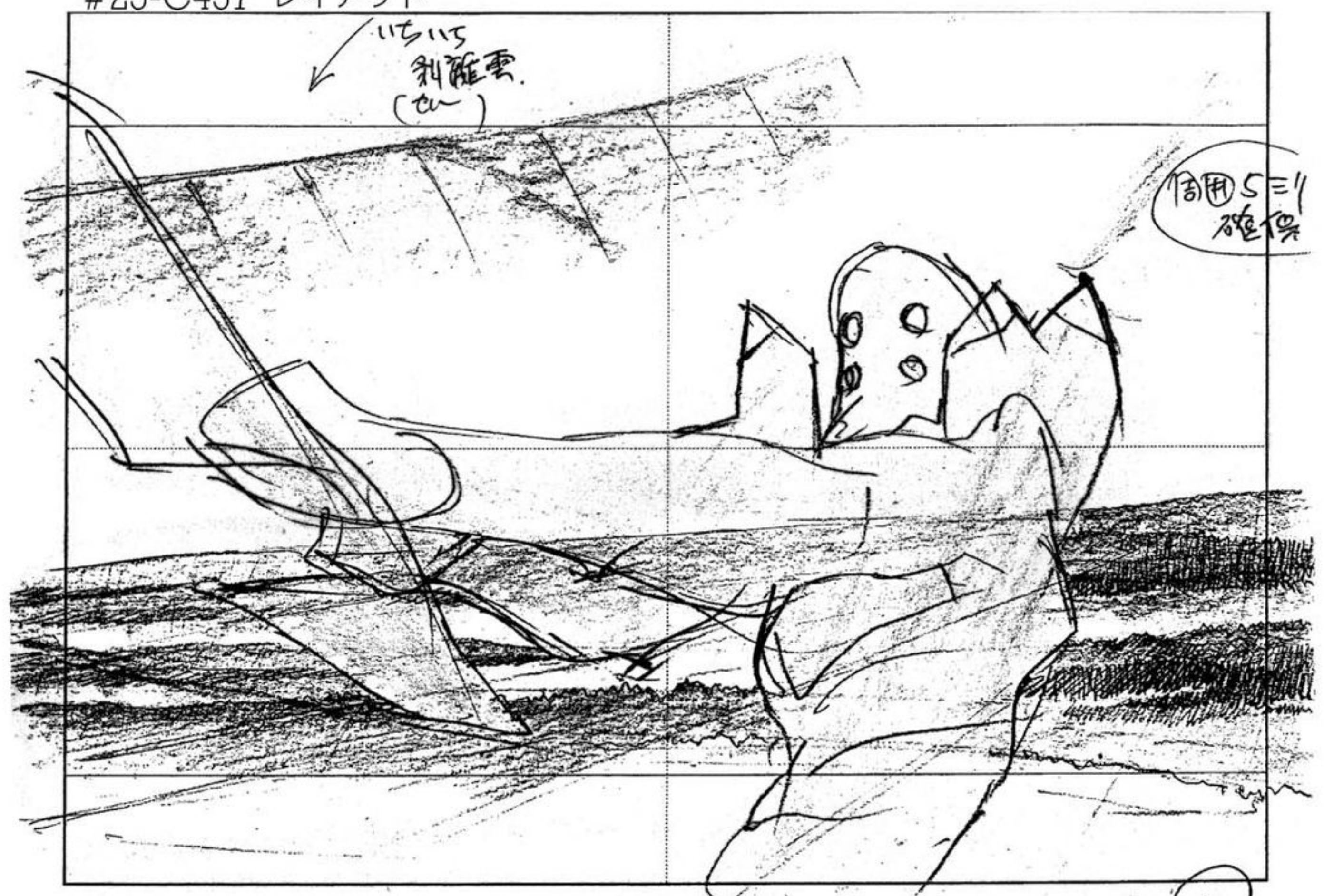





A1

#25-C473



A3



A2







タイムシート

A/B	
①	X
	2
	4
	6
	8
	10
	12
②	
	14
	16
	18
③	
	20
	22
	24
④	
	26
	28
⑤	
	30
	32
	34
⑥	
	36
⑦	
	38
	40
⑧	
	42
	44
⑨	
	46
	48
⑩	
	50



修正原画

B-2  
修正

修正原画

B-1  
修正







修正原画

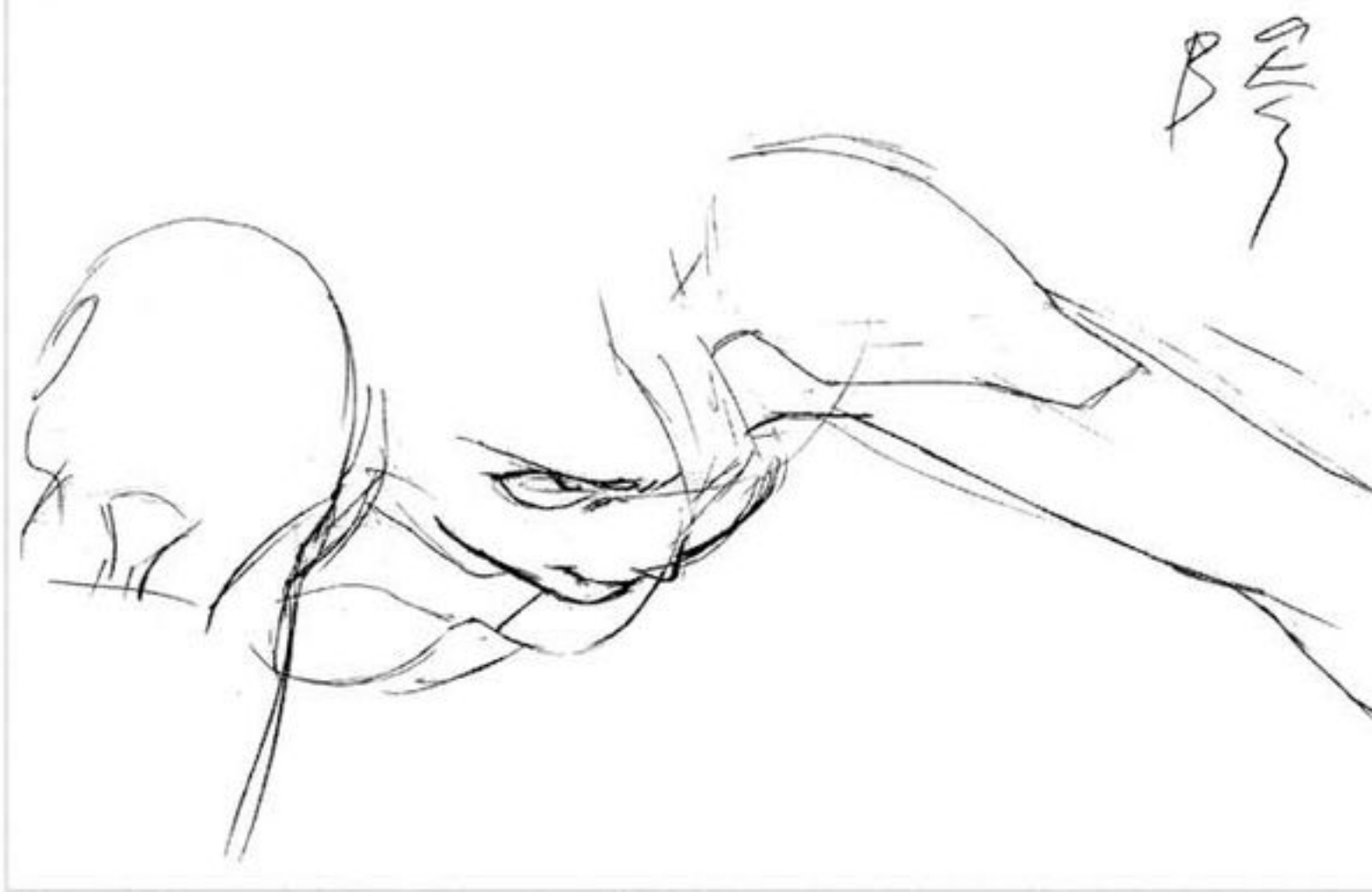

修正原画

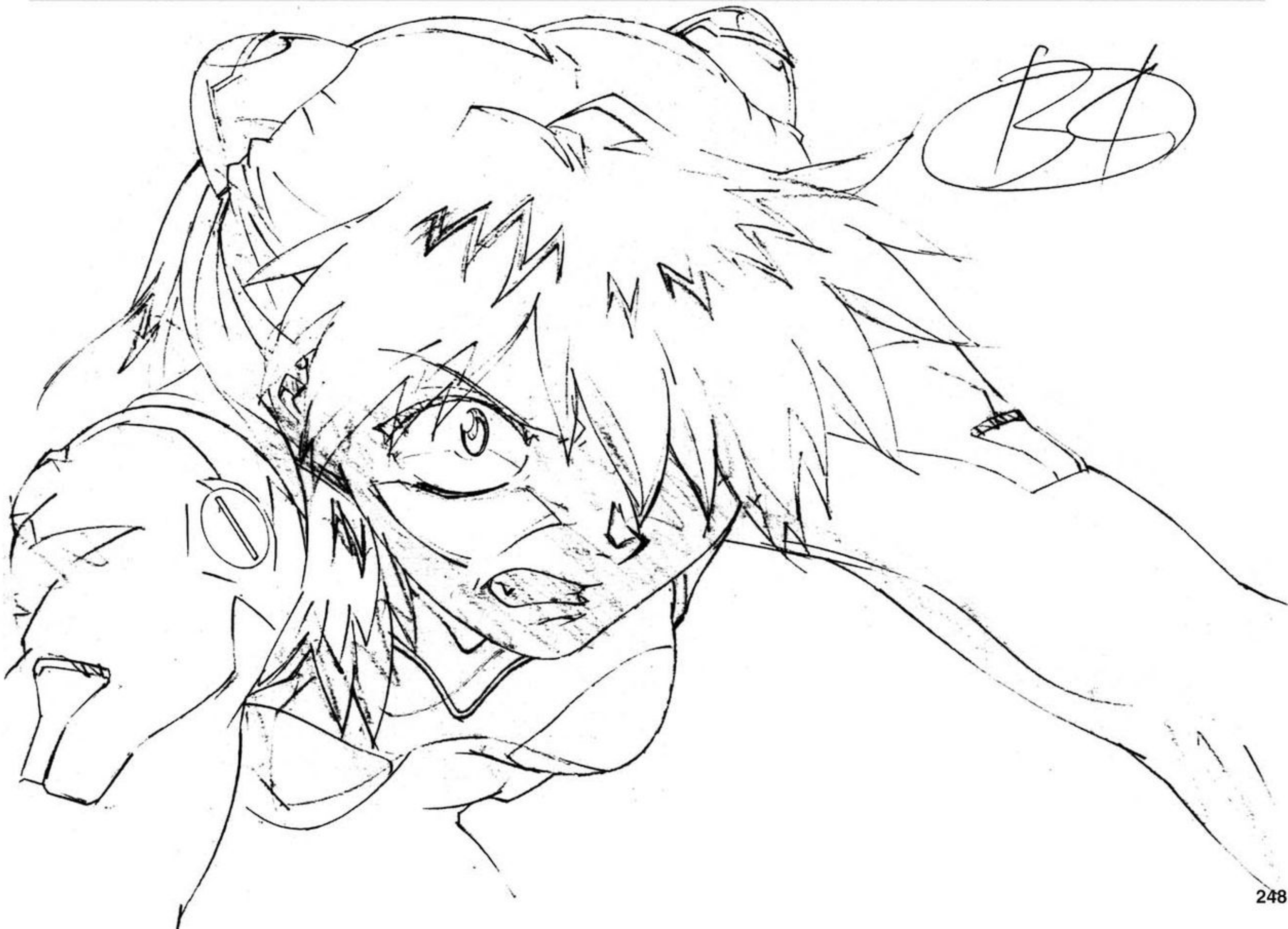
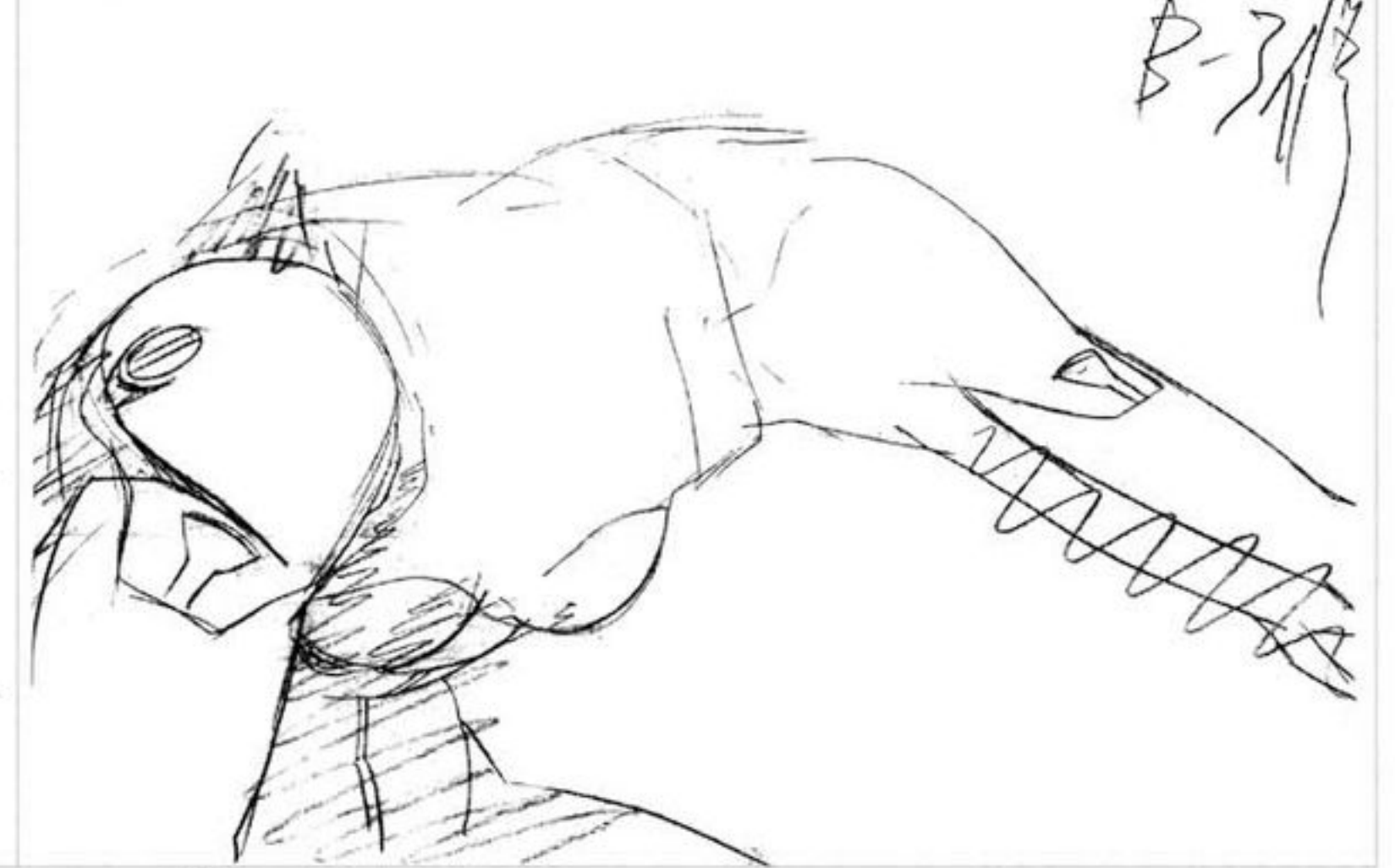



1	2	3	4	5	6	7	8	9	10	11	12	13	14	15	16	17	18	19	20	21	22	23	24	25	26	27	28	29	30	31	32	33	34	35	36	37	38	39	40	41	42	43	44	45	46	47	48	49	50	51	52	53	54	55	56	57	58	59	60	61	62
---	---	---	---	---	---	---	---	---	----	----	----	----	----	----	----	----	----	----	----	----	----	----	----	----	----	----	----	----	----	----	----	----	----	----	----	----	----	----	----	----	----	----	----	----	----	----	----	----	----	----	----	----	----	----	----	----	----	----	----	----	----

タイムシート

修正原画



修正原画





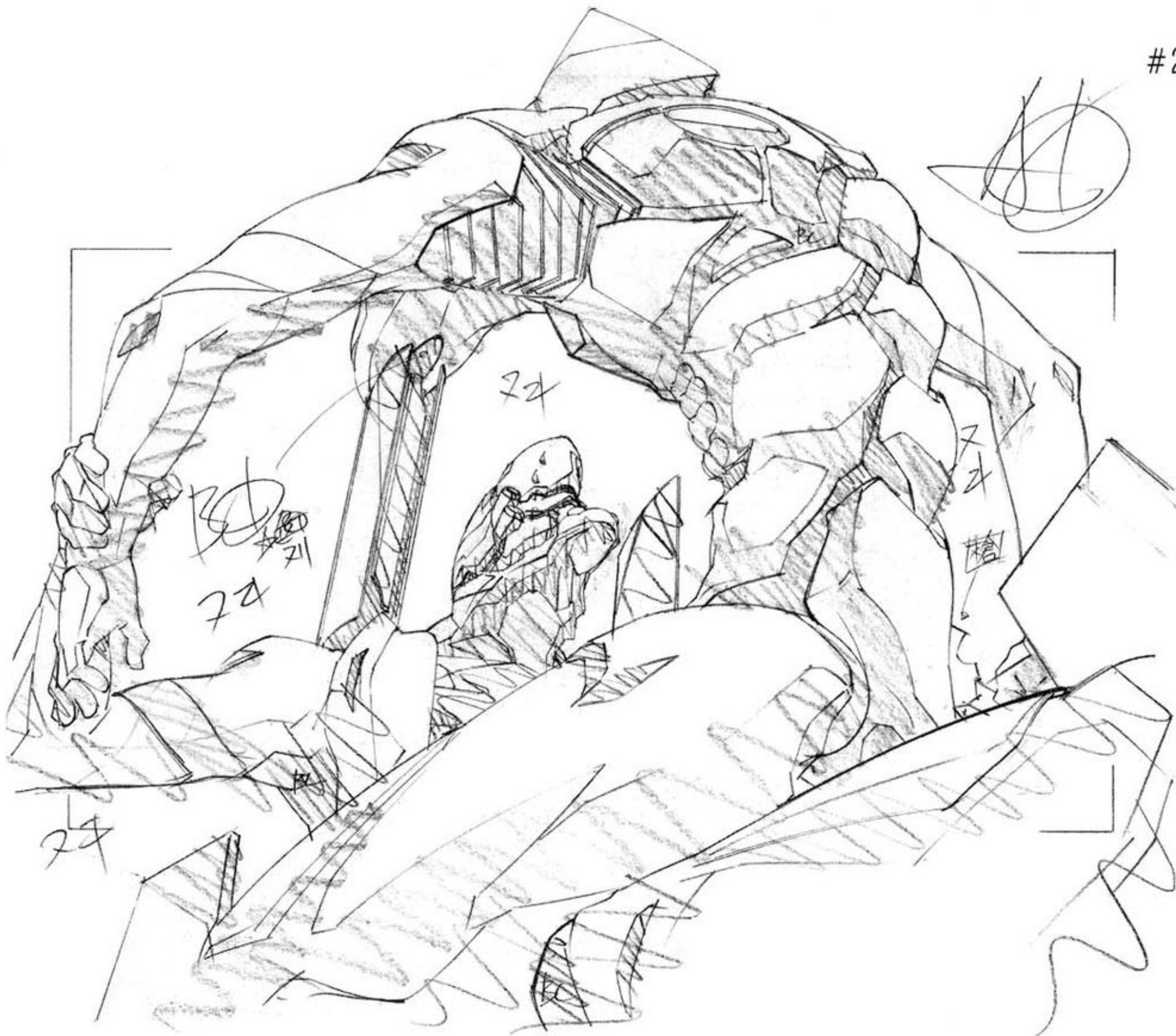





A	B	C		
①	X	X		2
	②			4
②	X	①		6
③	②			8
④	③			10
①	①			12
①	①			14
①	①			16
①	①			18
①	①			20
①	①			22
①	①			24
①	①			26
①	①			28
⑤	④			30

タイムシート

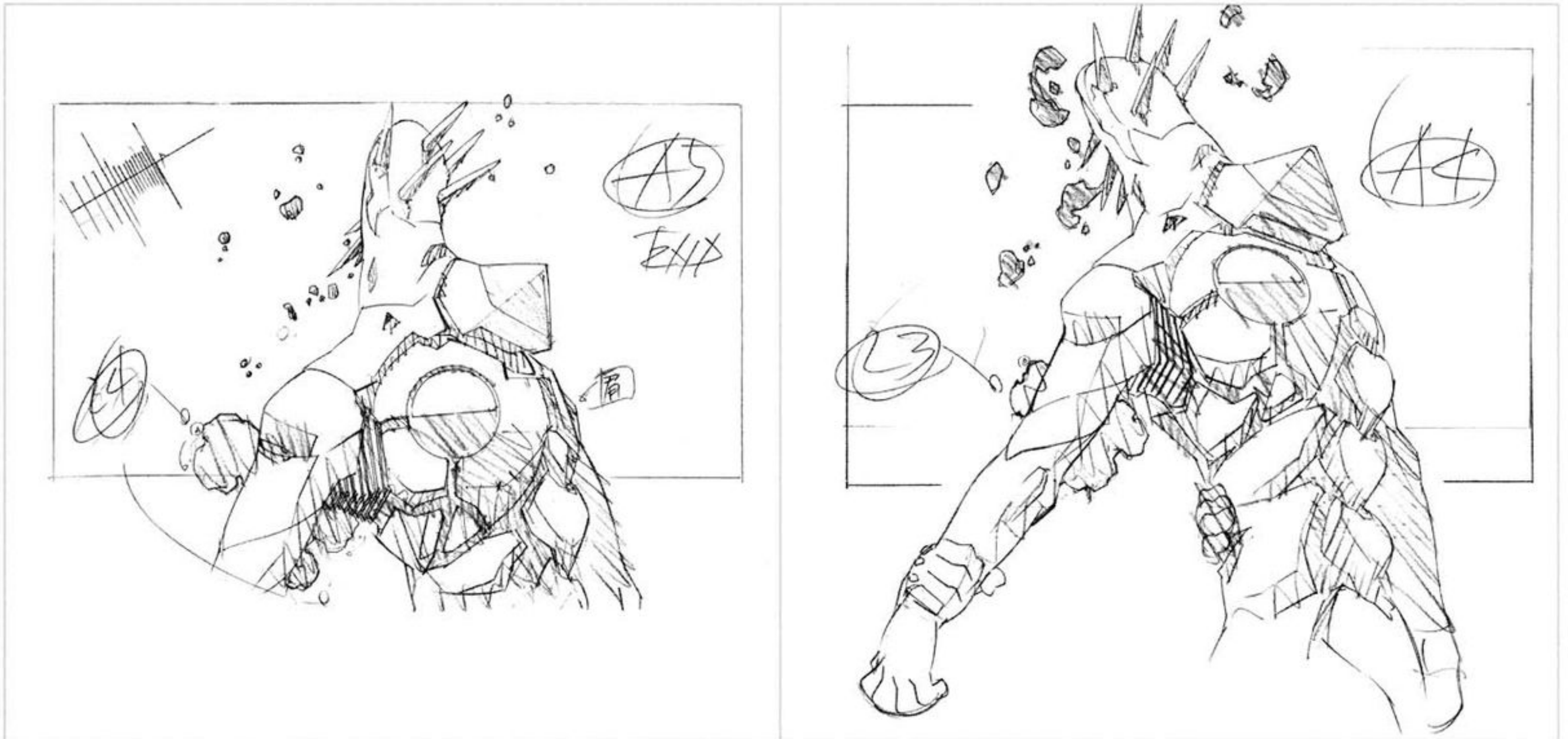



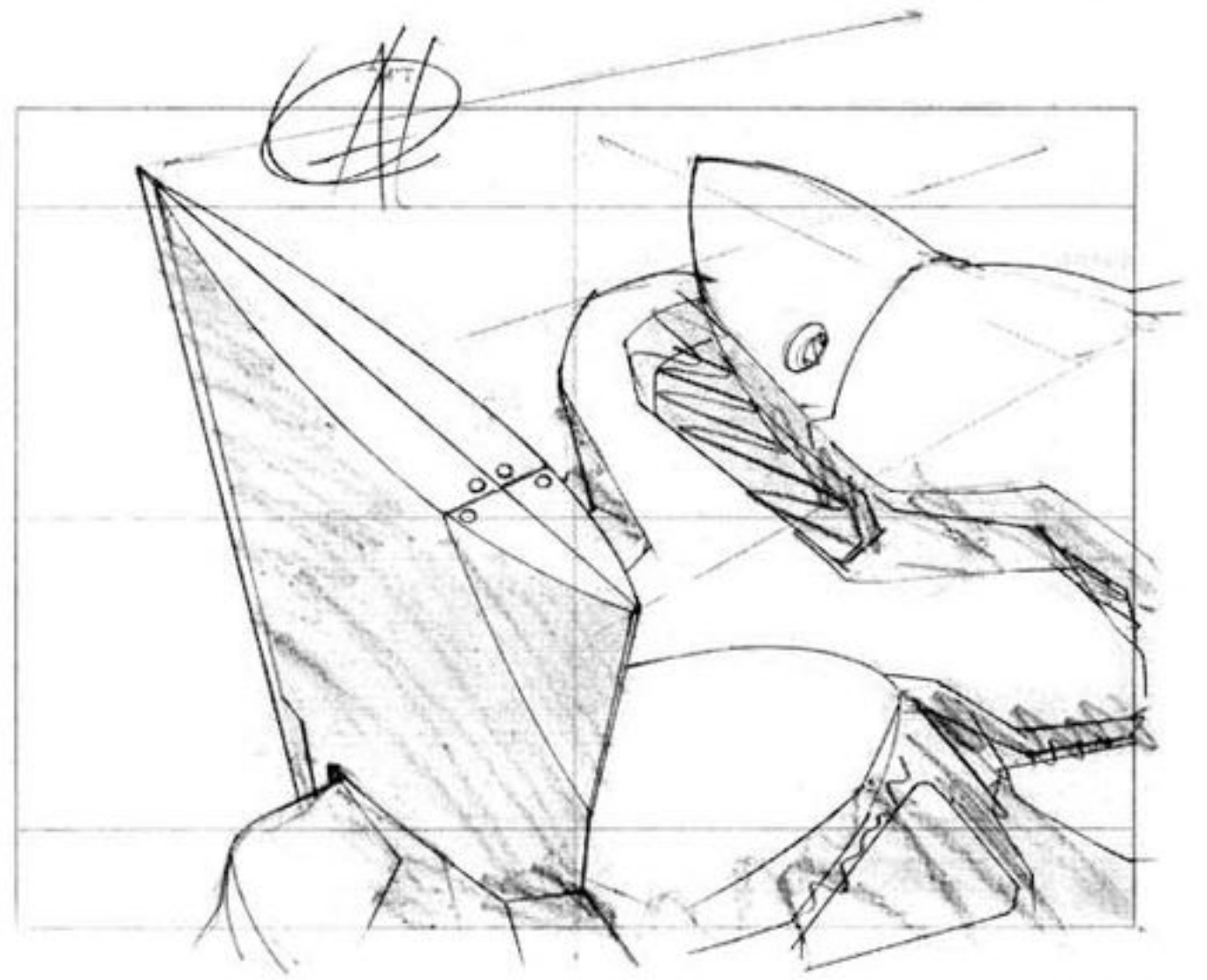
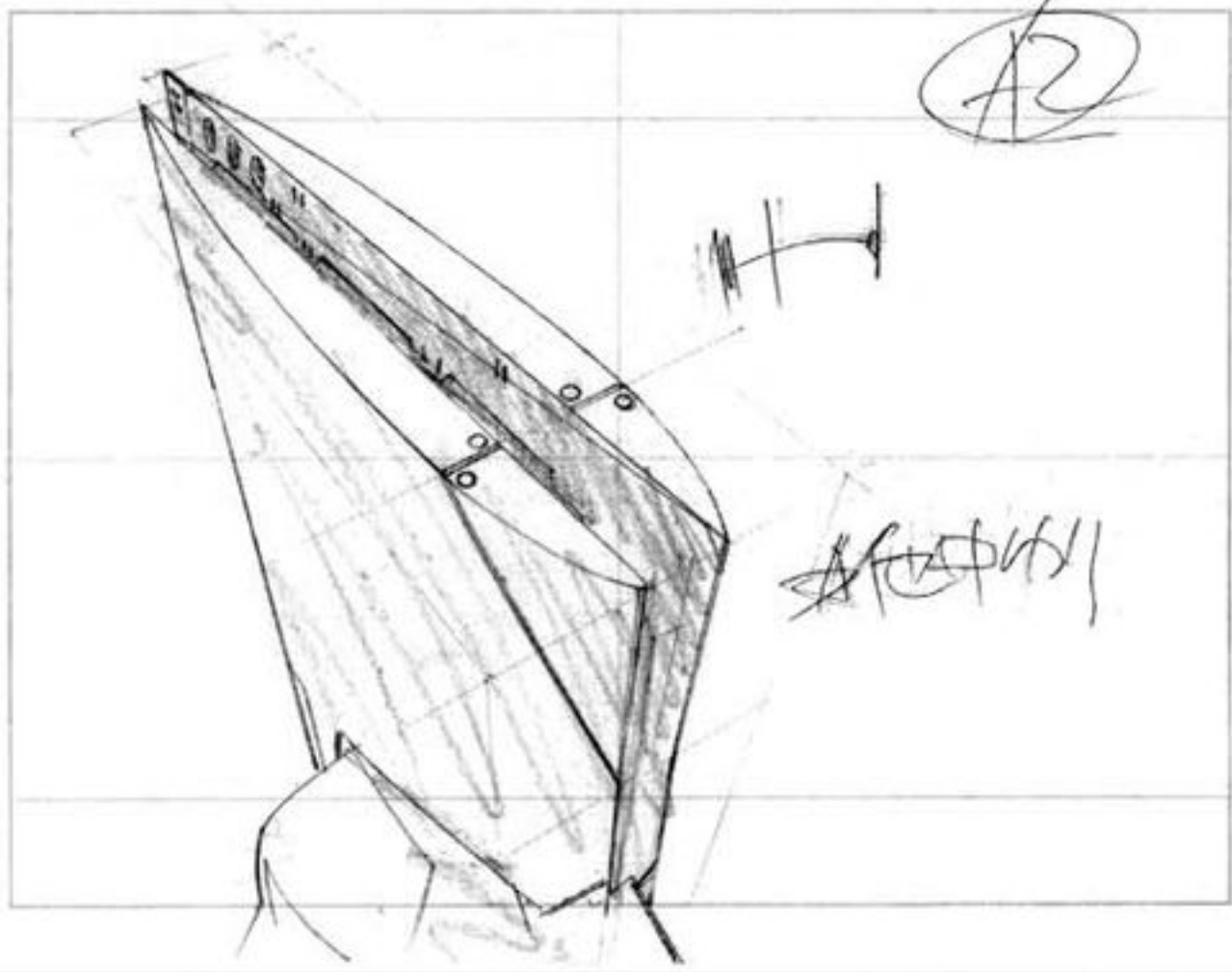

修正原画

(A3)

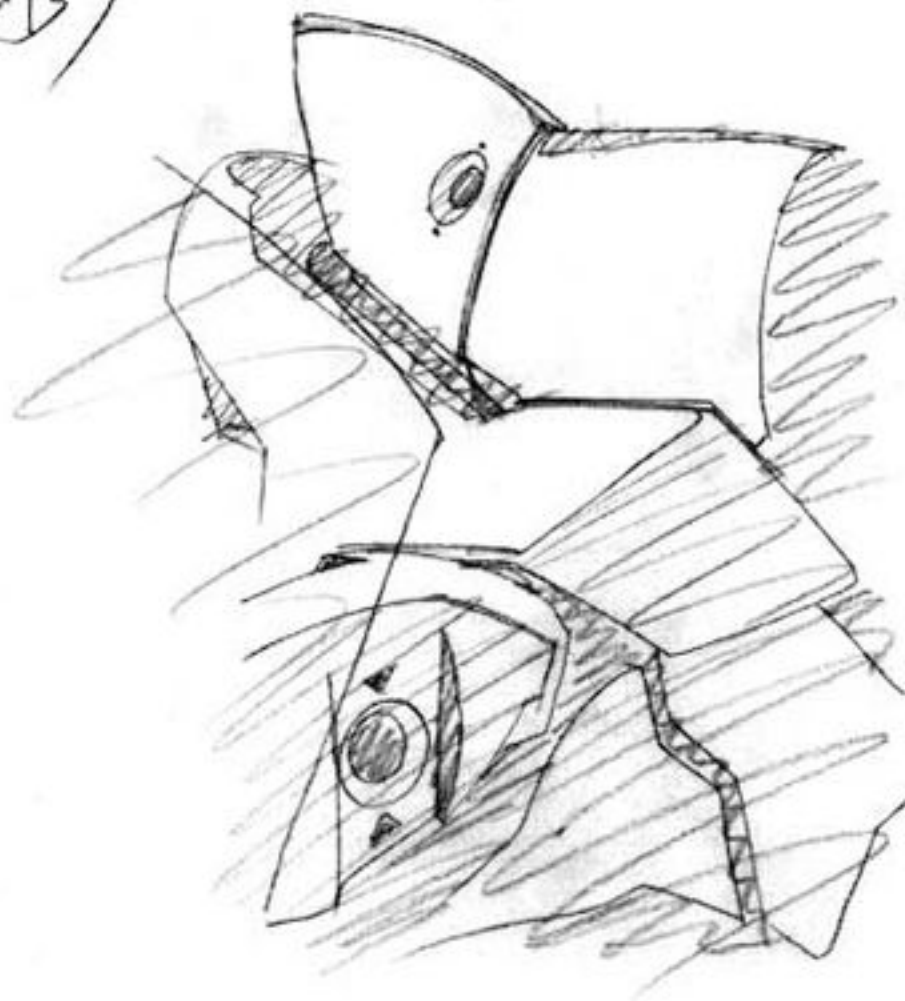

修正原画

(A1)

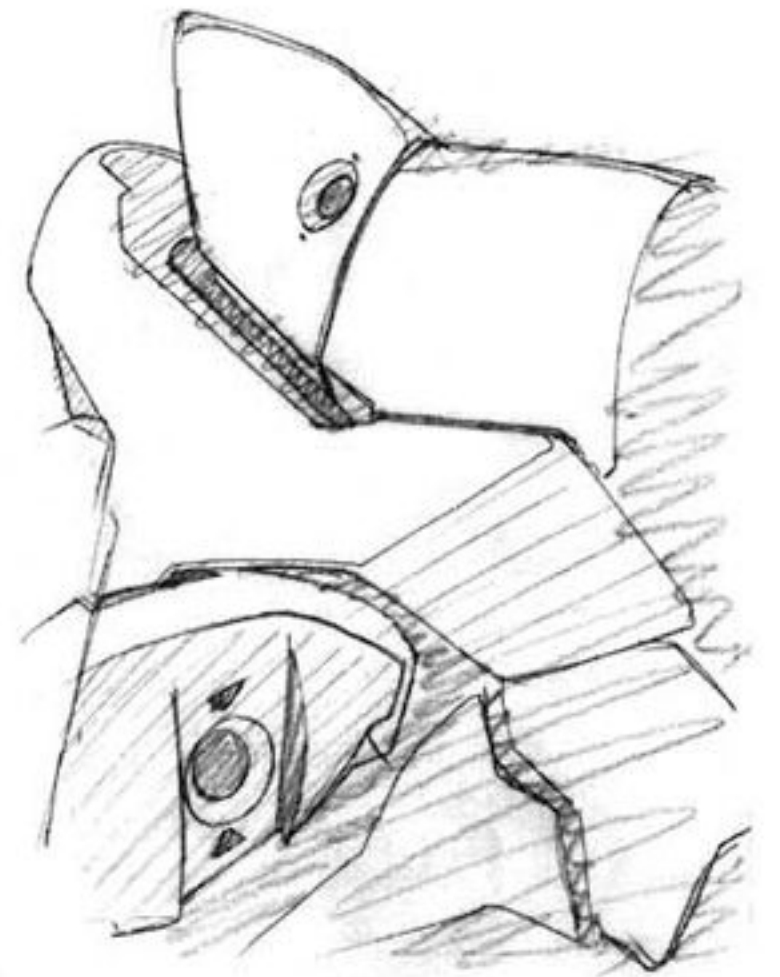

#25-C447

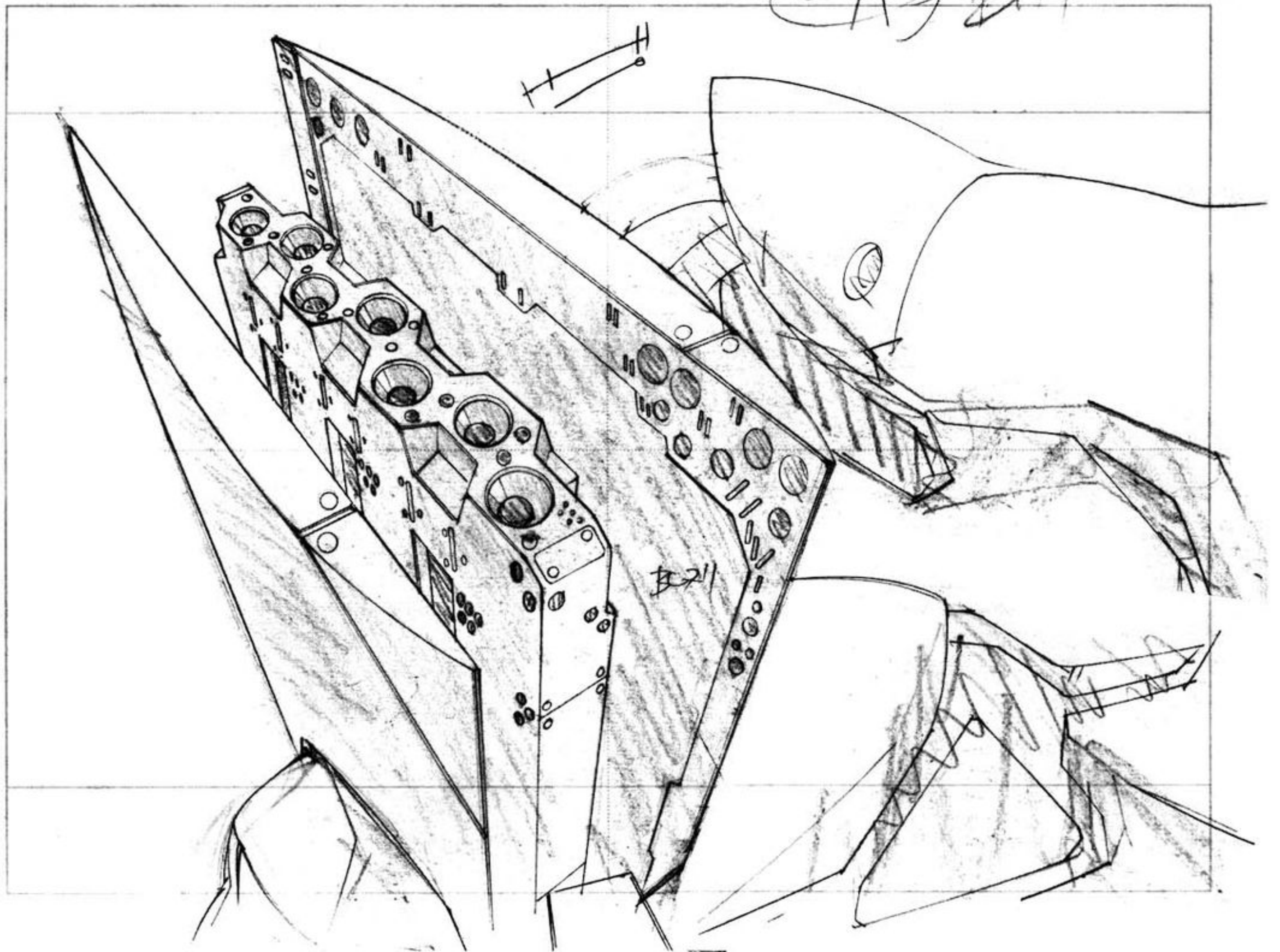



AK		
00		
		2
		4
		6
(2)		8
		10
		12
		14
		16
		18
		20
		22
		24
		26
(4)		28

修正原画

B201



#25-C480

(B)



タイムシート

修正原画

修正



修正原画

B-4



(B)





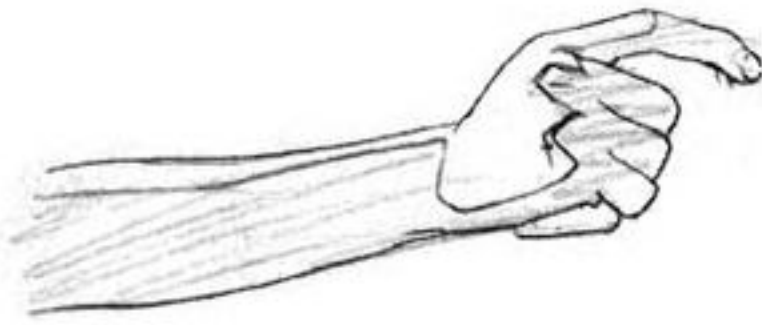

A2 修正  
修正原画

修正原画



A1  
修正原画



A3  
修正原画



修正原画



A1 修正

修正原画



A4



修正原画



A2  
修正原画

修正原画













#25-C488,490



修正原画







#25-C500

修正原画







修正原画



修正原画







修正原画







#25-C501

修正原画

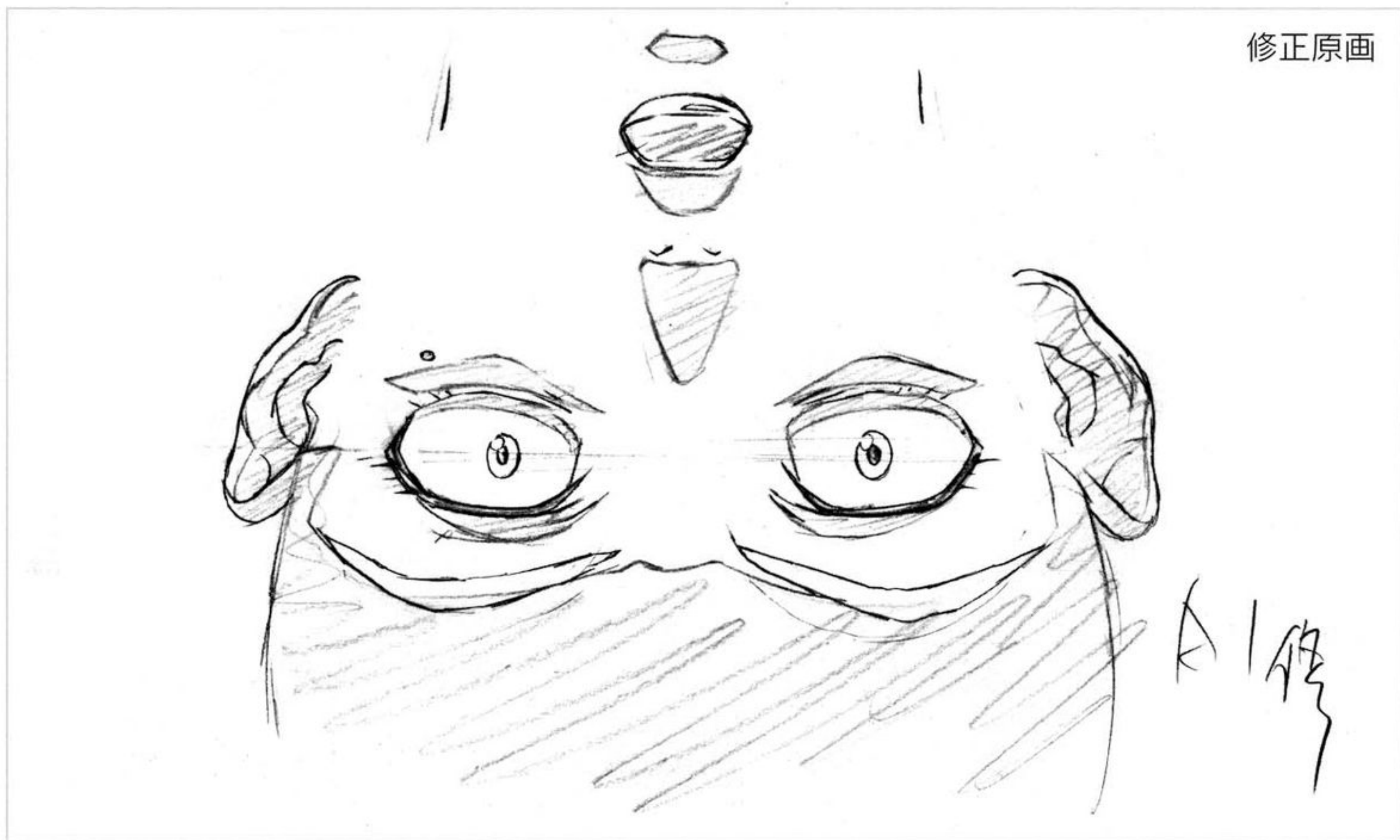

A1修



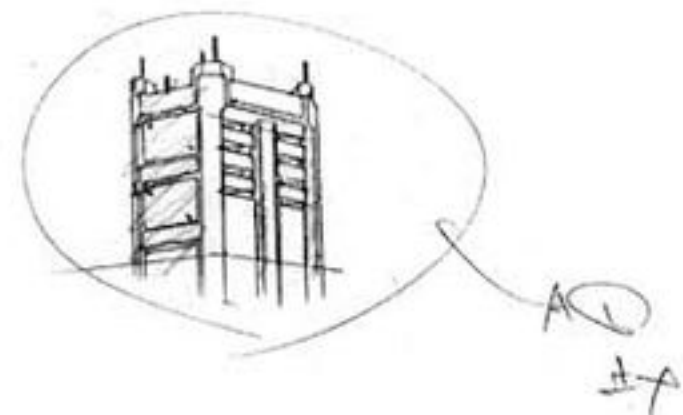
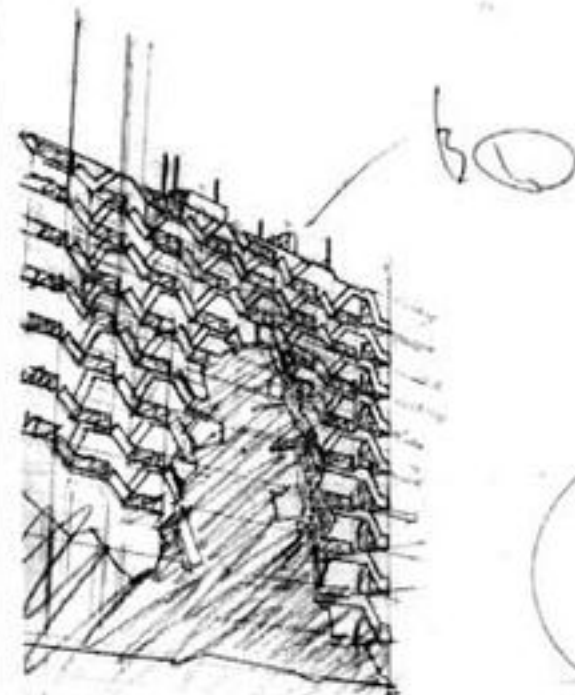

→ 大机

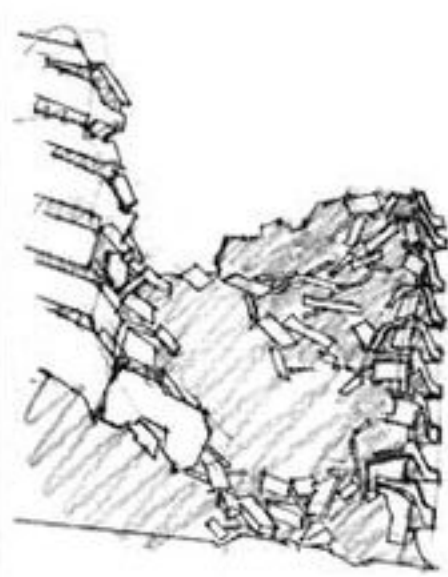

→ END

修正原画





修正原画  
C4



修正原画  
C2



C4

修正原画



C2

修正原画

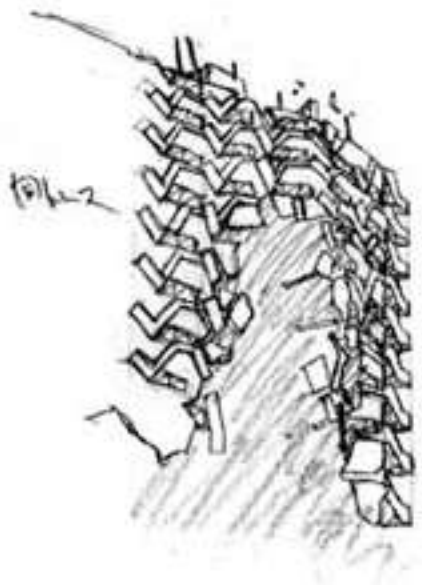

修正原画  
C4



C3



修正原画  
C5



C3

修正原画



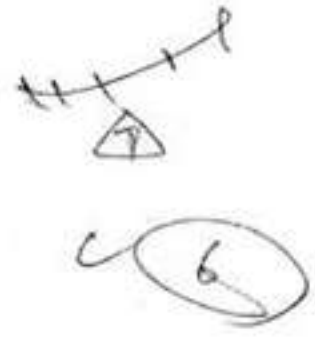

修正原画

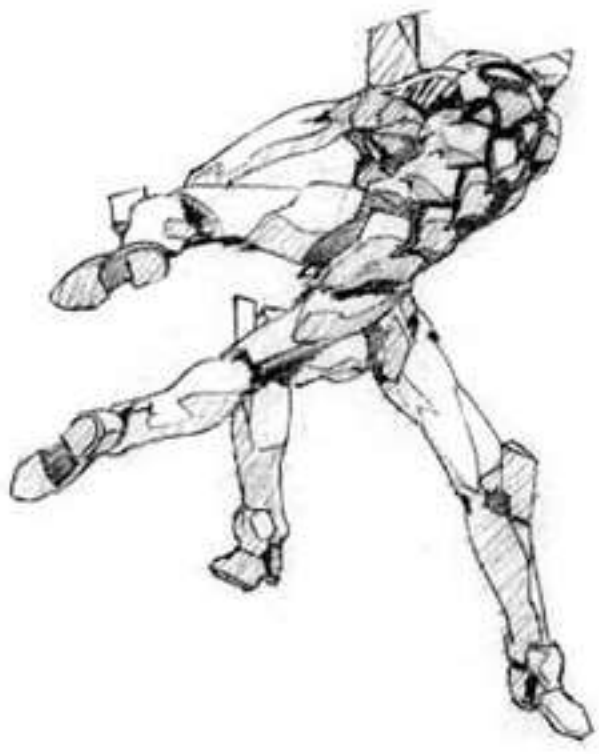

修正原画

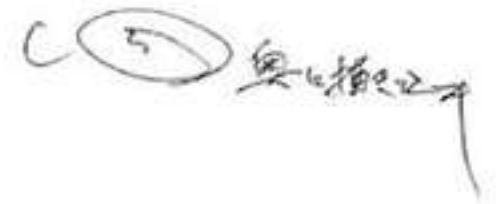
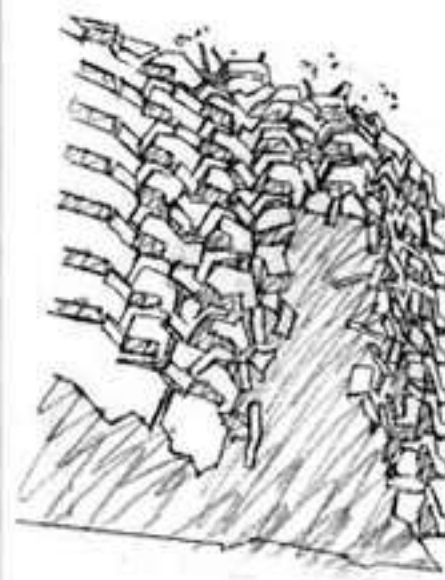

修正原画



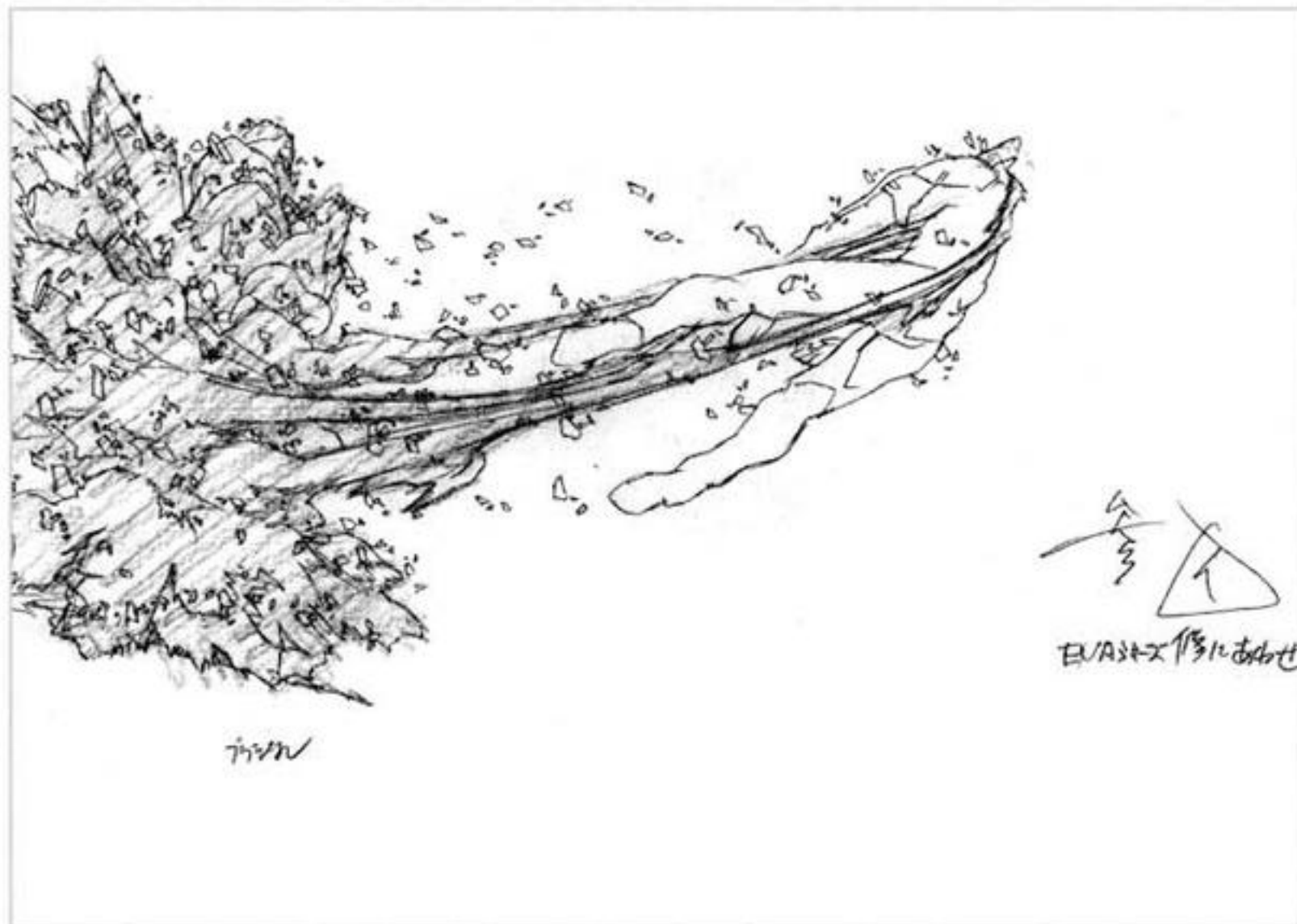

EVANGELION  
Tanimoto



修正原画

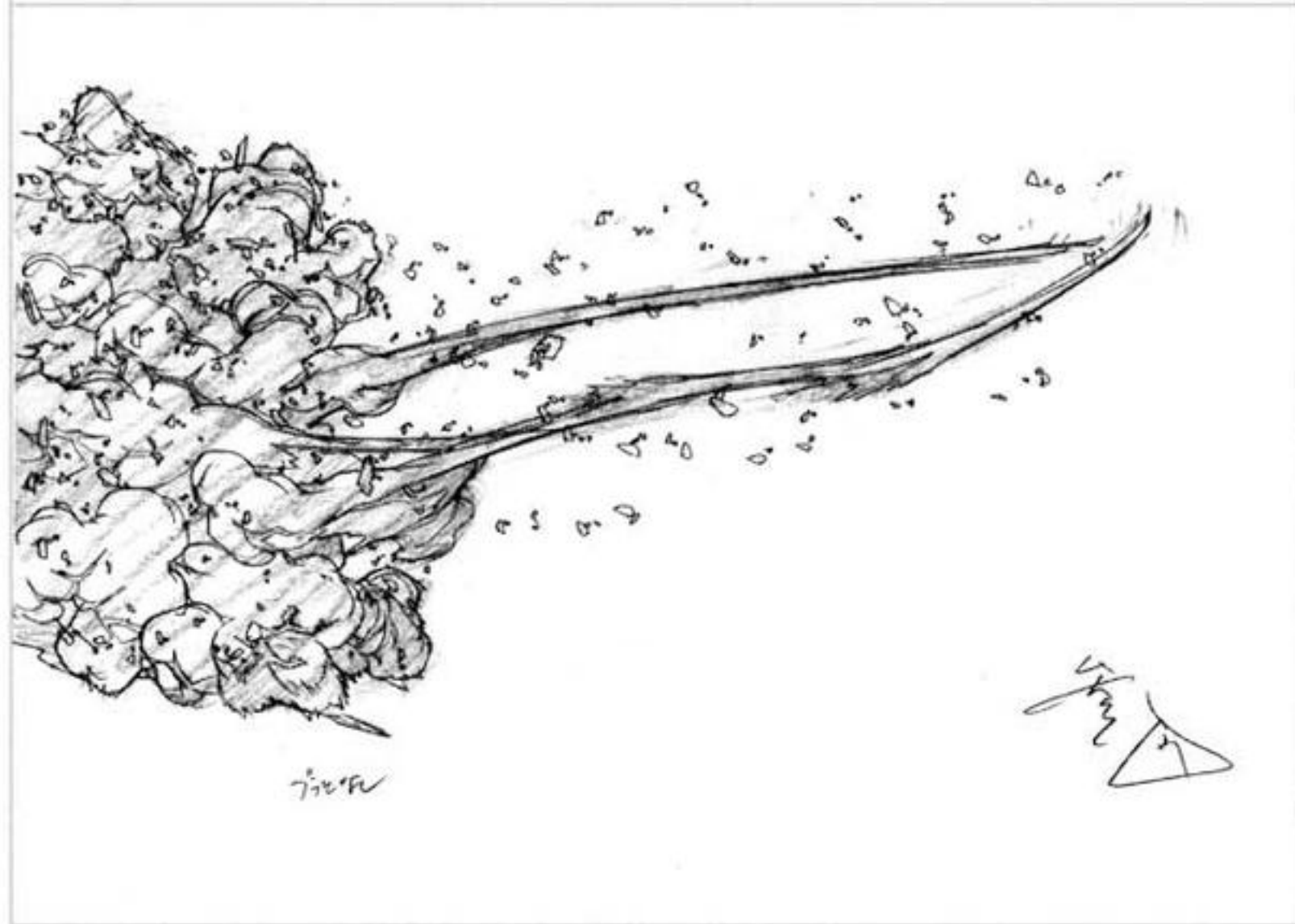

EVANGELION  
Tanimoto

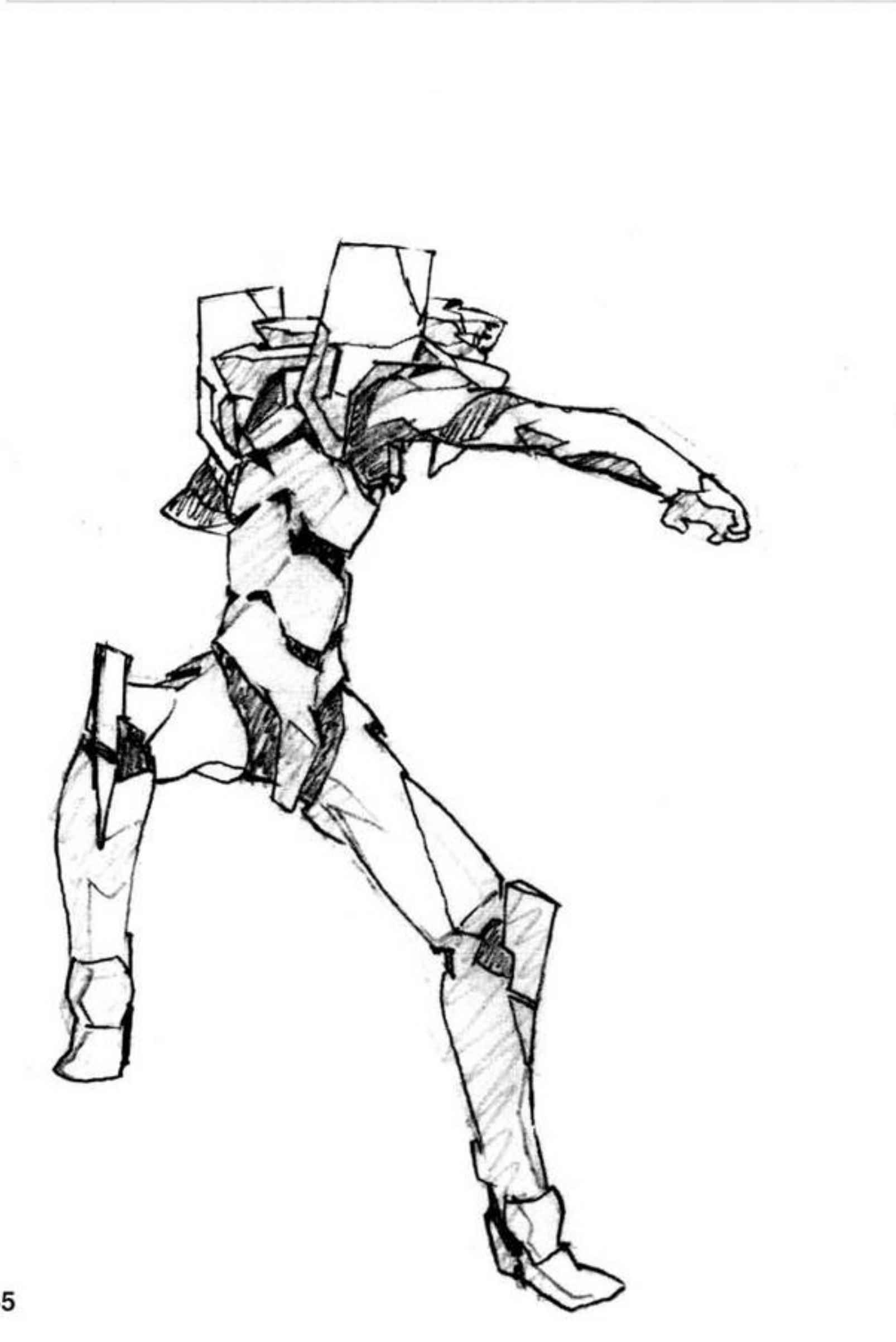
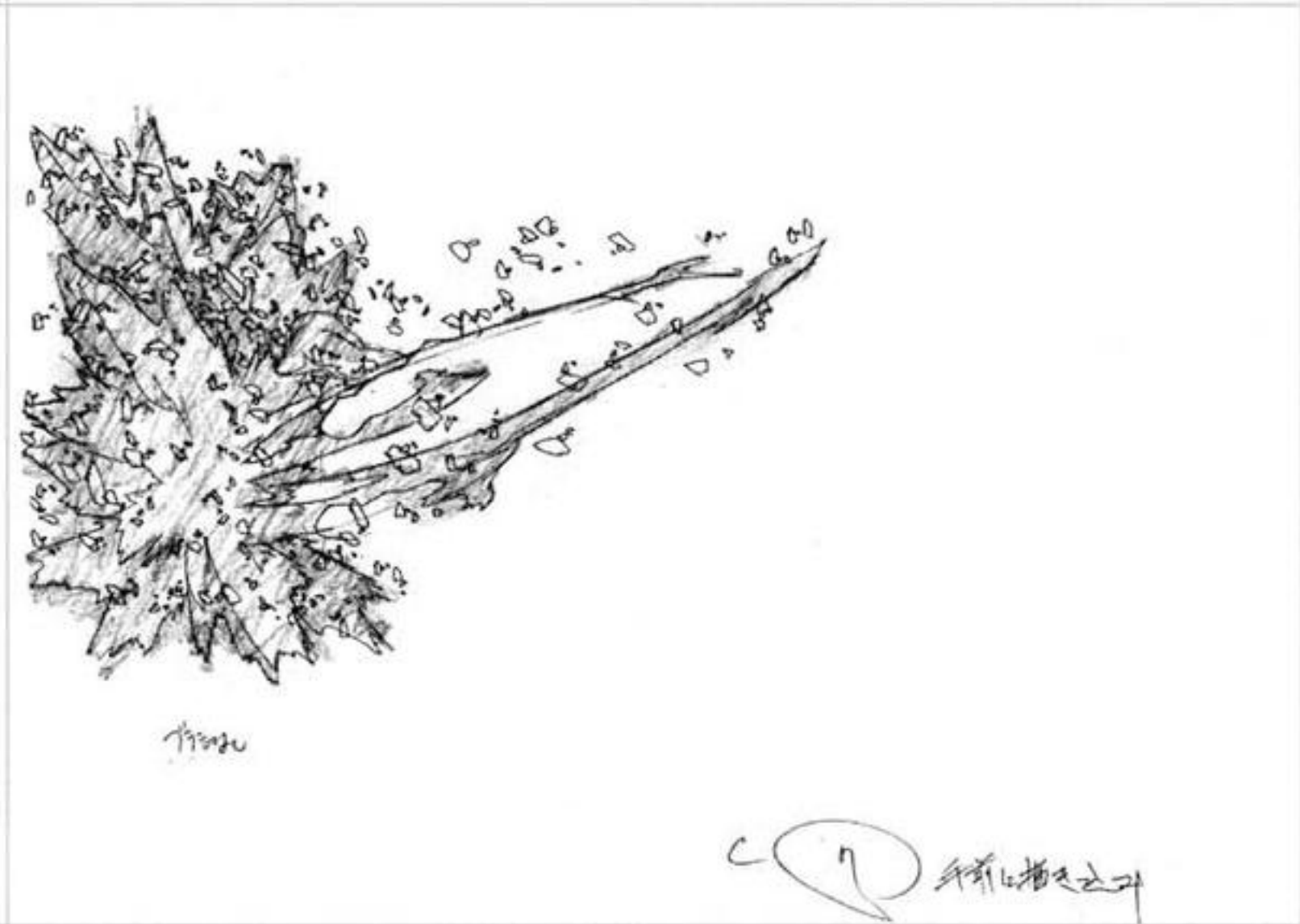

修正原画



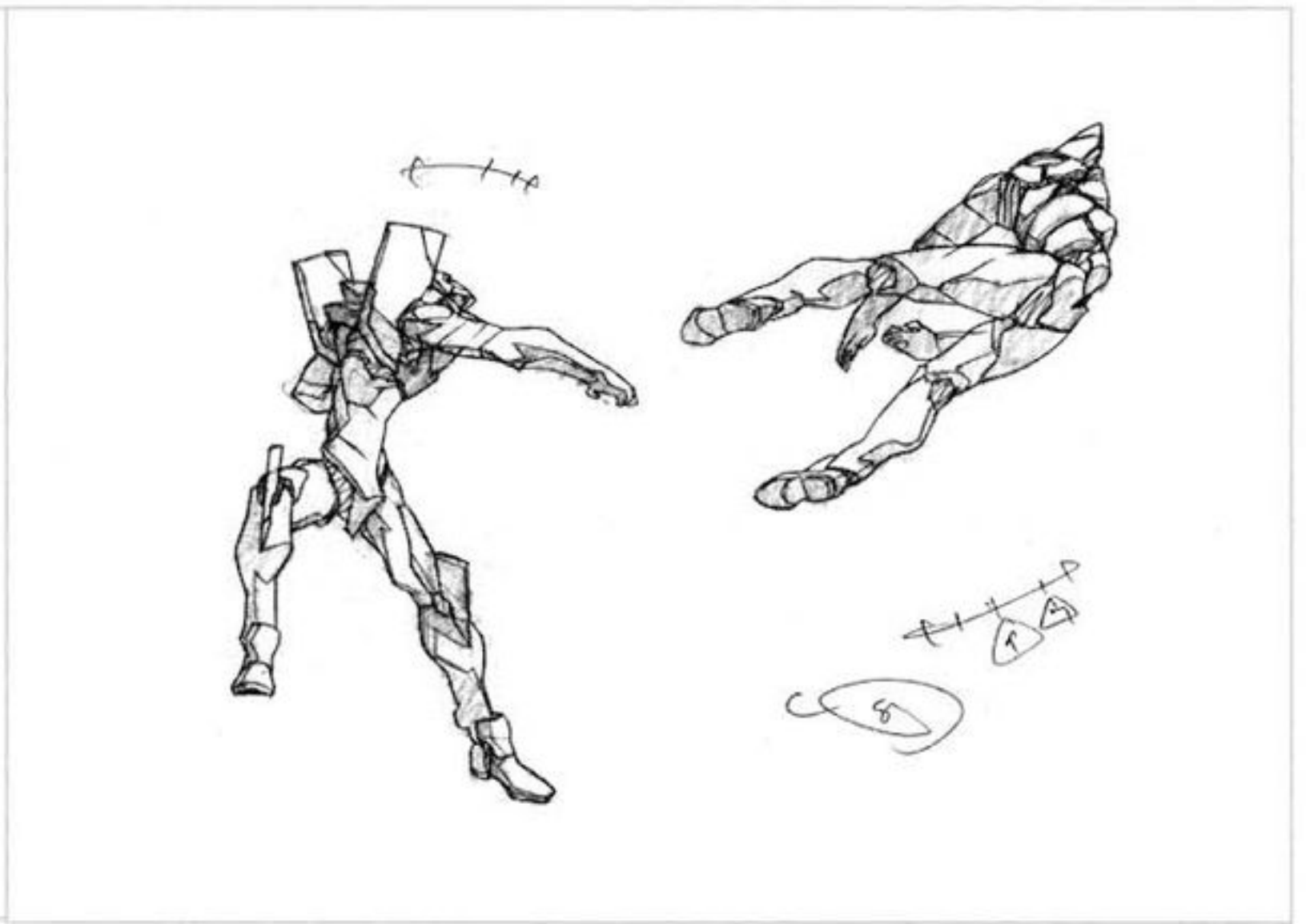
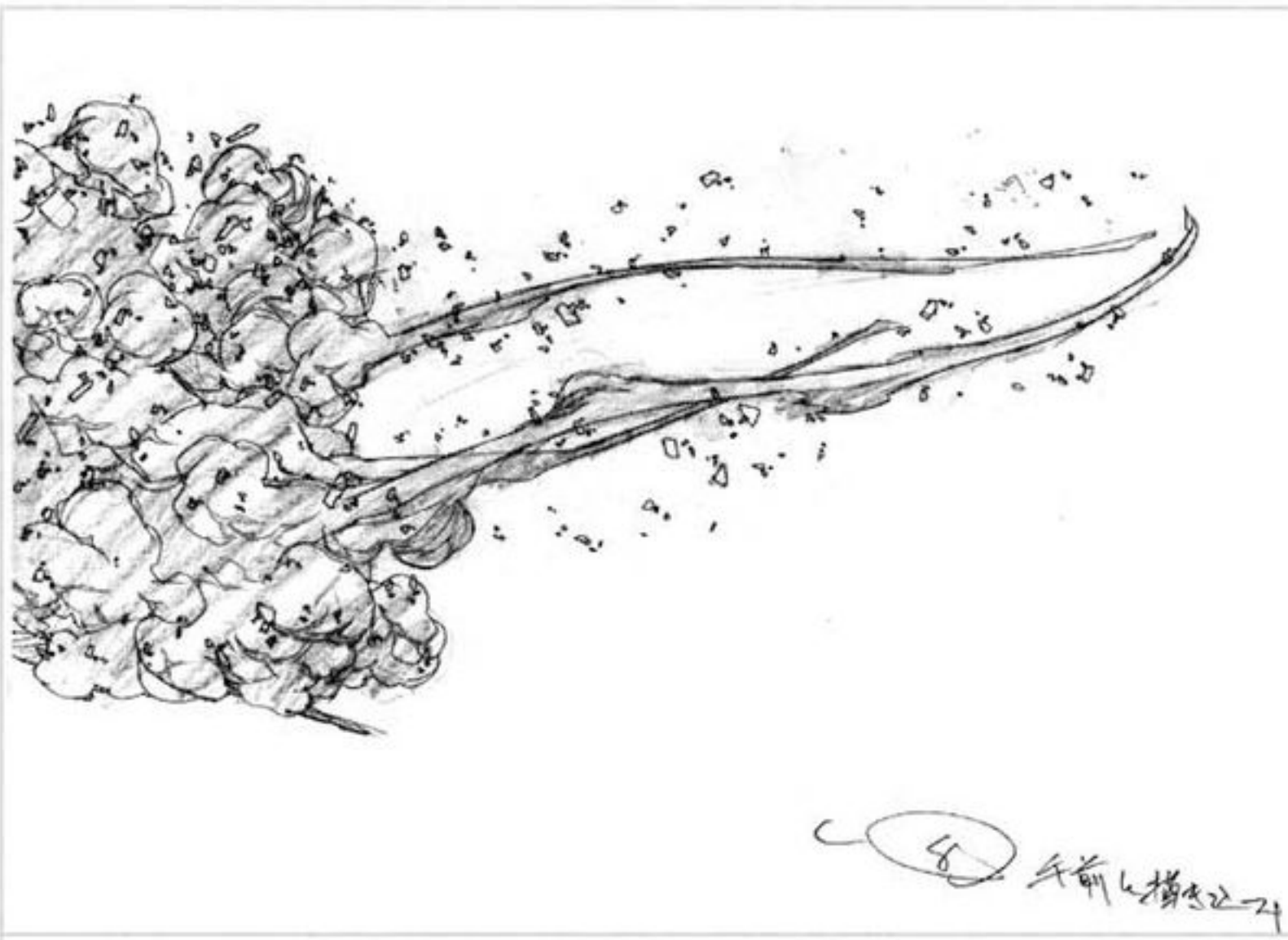

④ 年前的構思

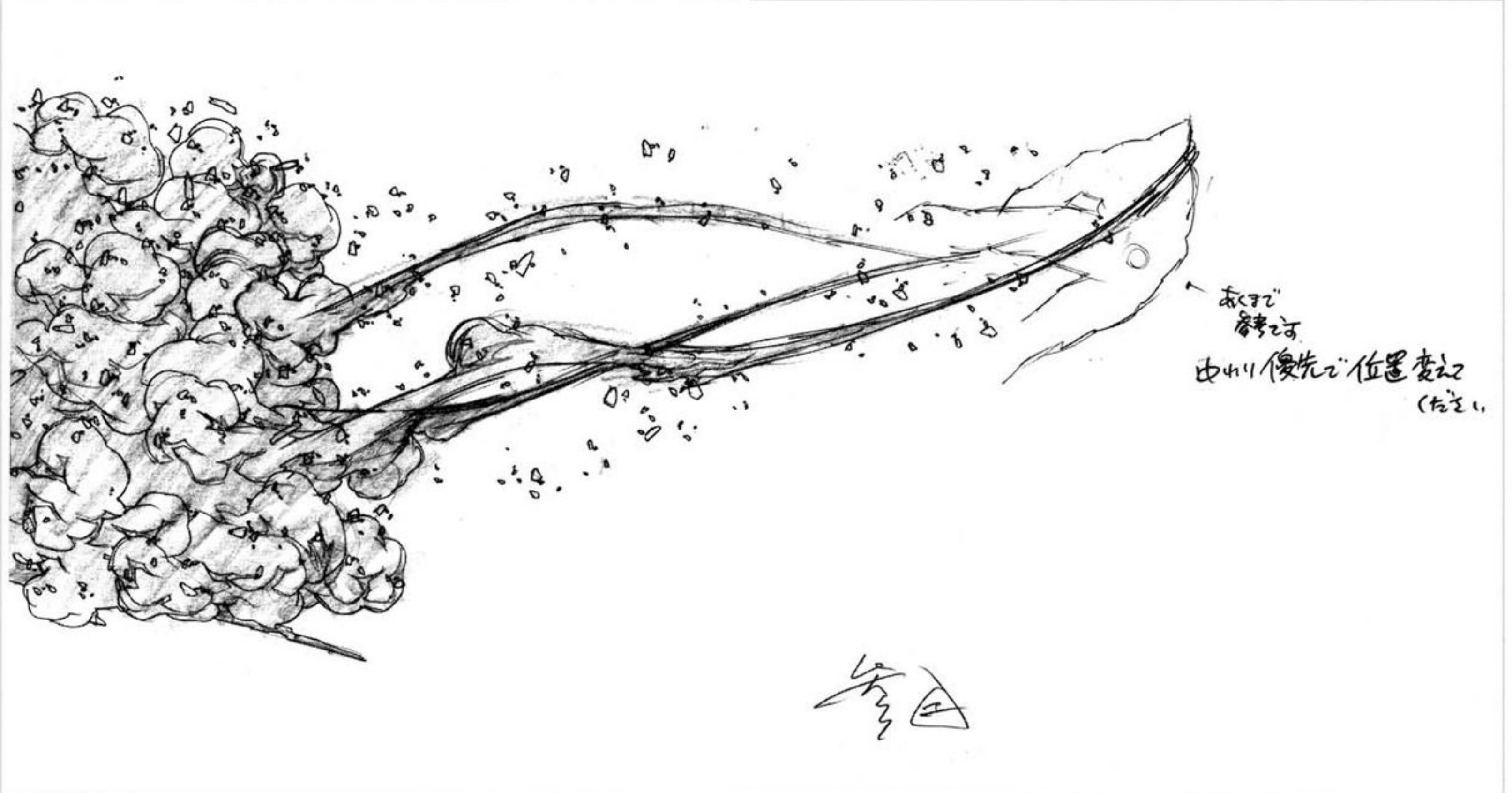

→ 前の構思  
 中より優先の位置変化  
 (左足)

△

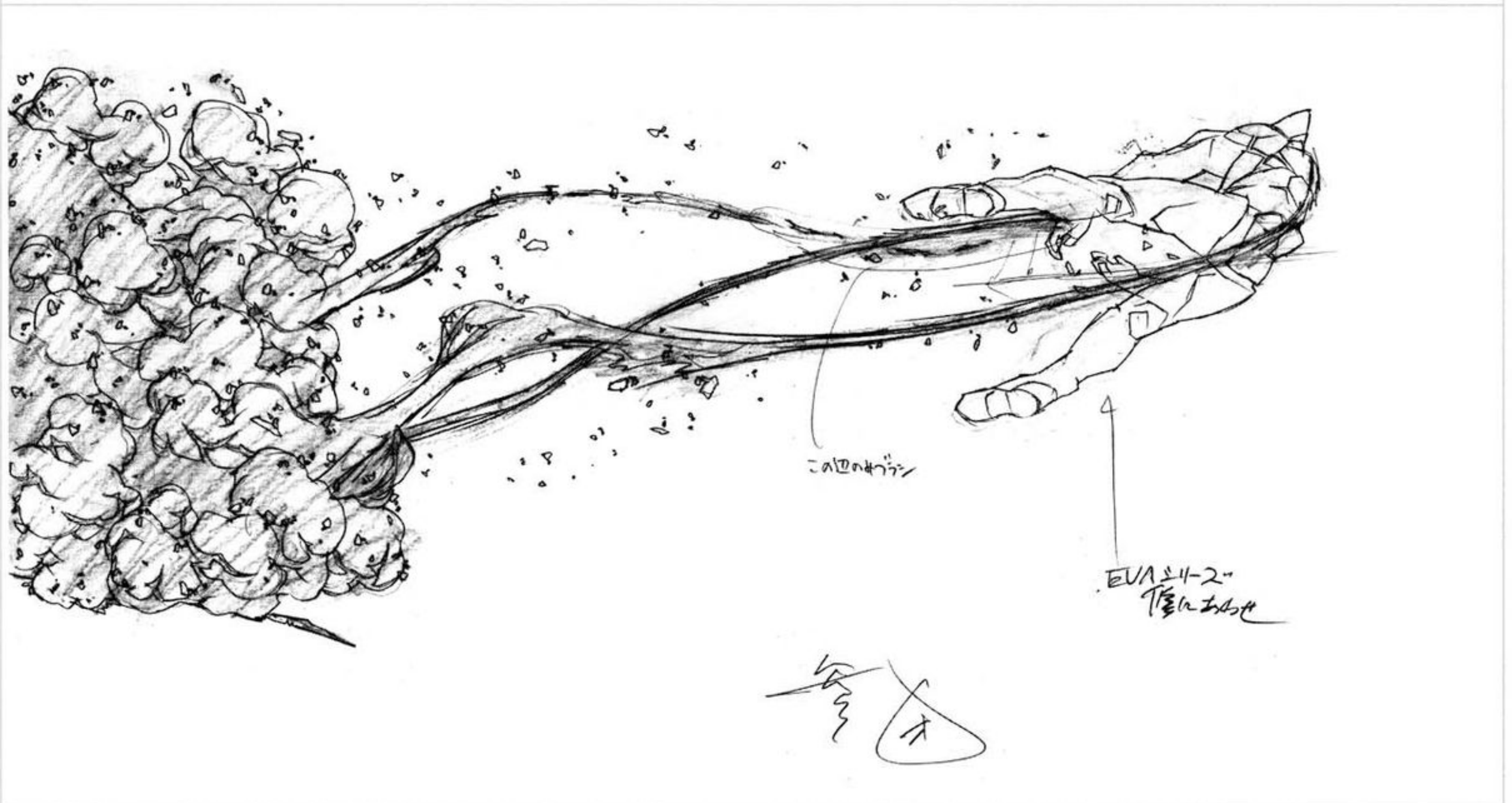

△

EVA 34-2  
 足の動き

△





修正原画

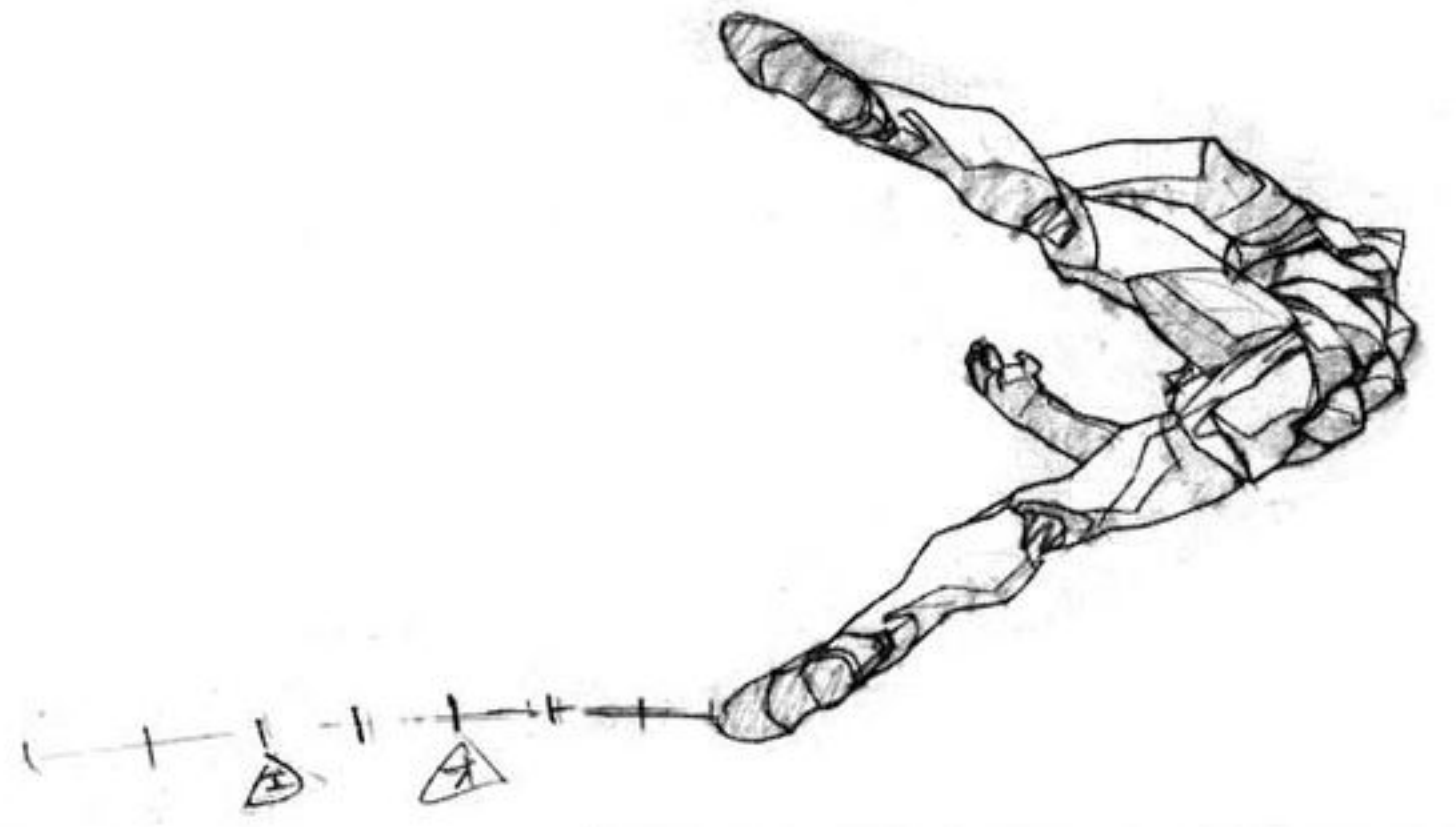

修正原画

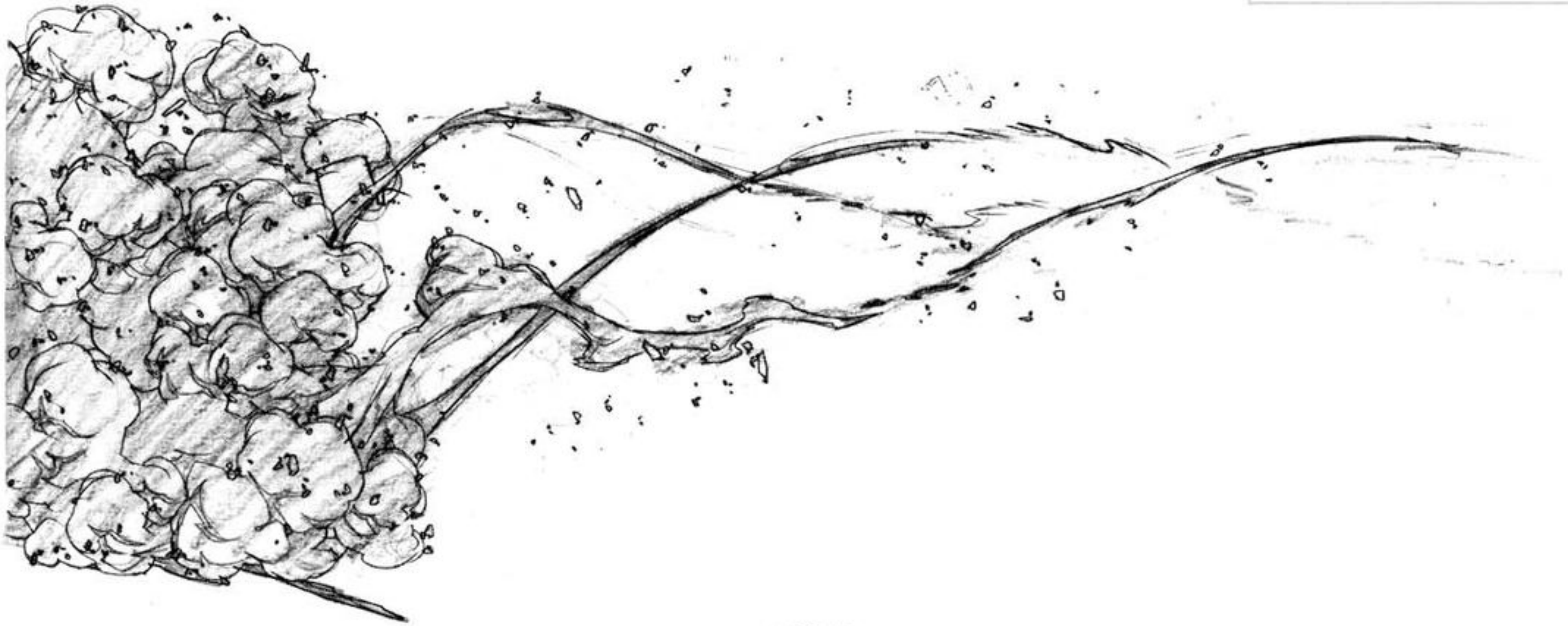

9 年前に描いた

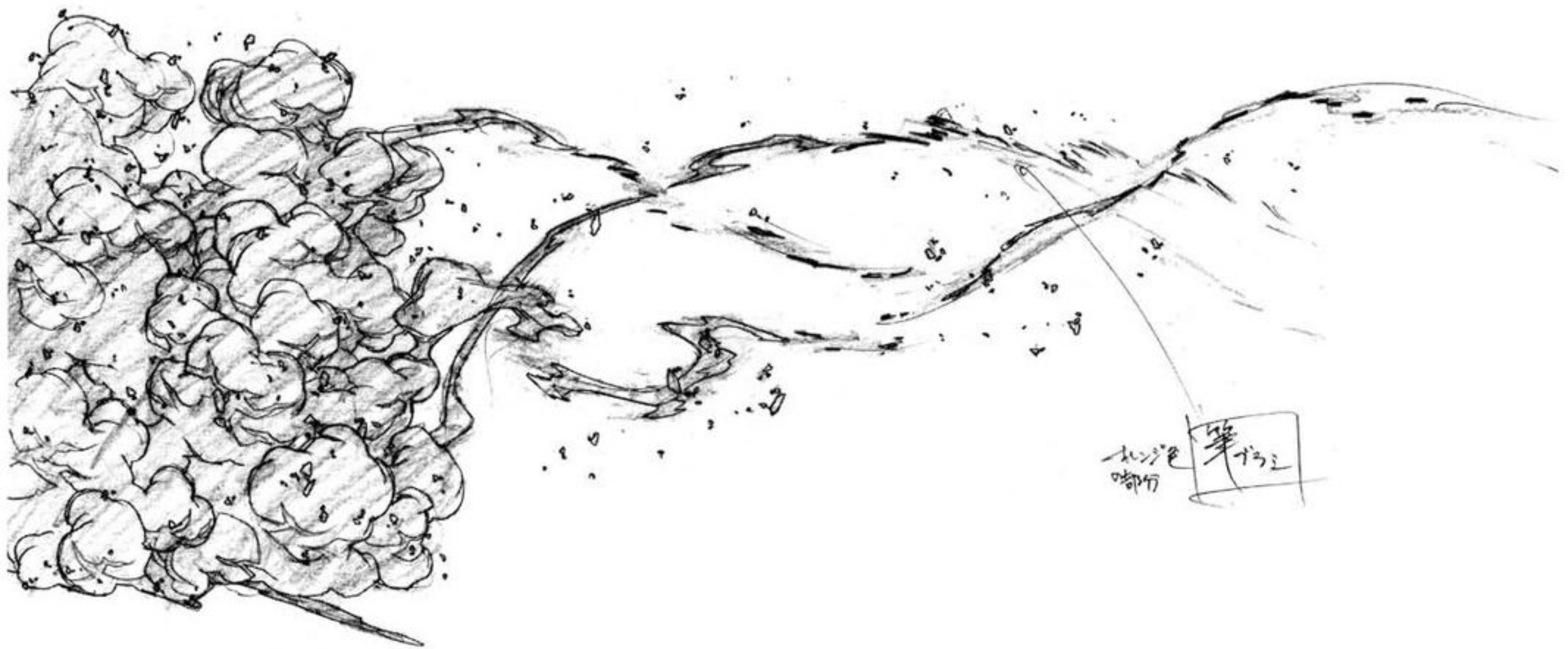

足の色  
脚の

足 9



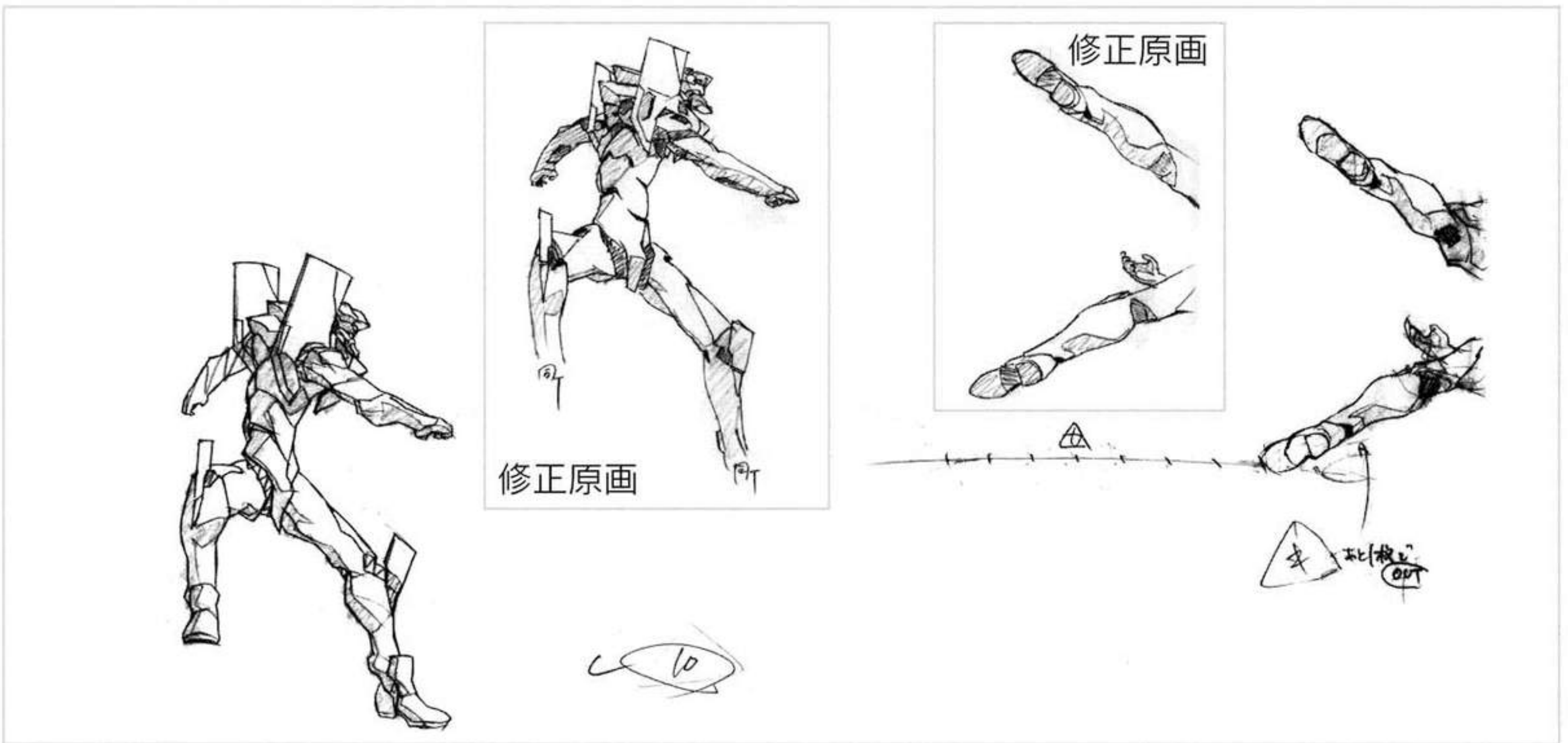

A	B	C	D	E
①	①	①	x	①
F				2
f				4
				6
				8
	②			10
				12
	③			14
x				16
	④			18
				20
				22
				24

		26
		28
⑤		30
	⑥	32
		34
②⑥		36
		38
	⑦	40
		42
	⑧	44
	⑨	46
	⑩	48

	①	50
⑤		52
		54
⑥		56
		58
		60
⑨		62
		64
		66
⑩		68
		70
		72

#25-C515  
タイムシート



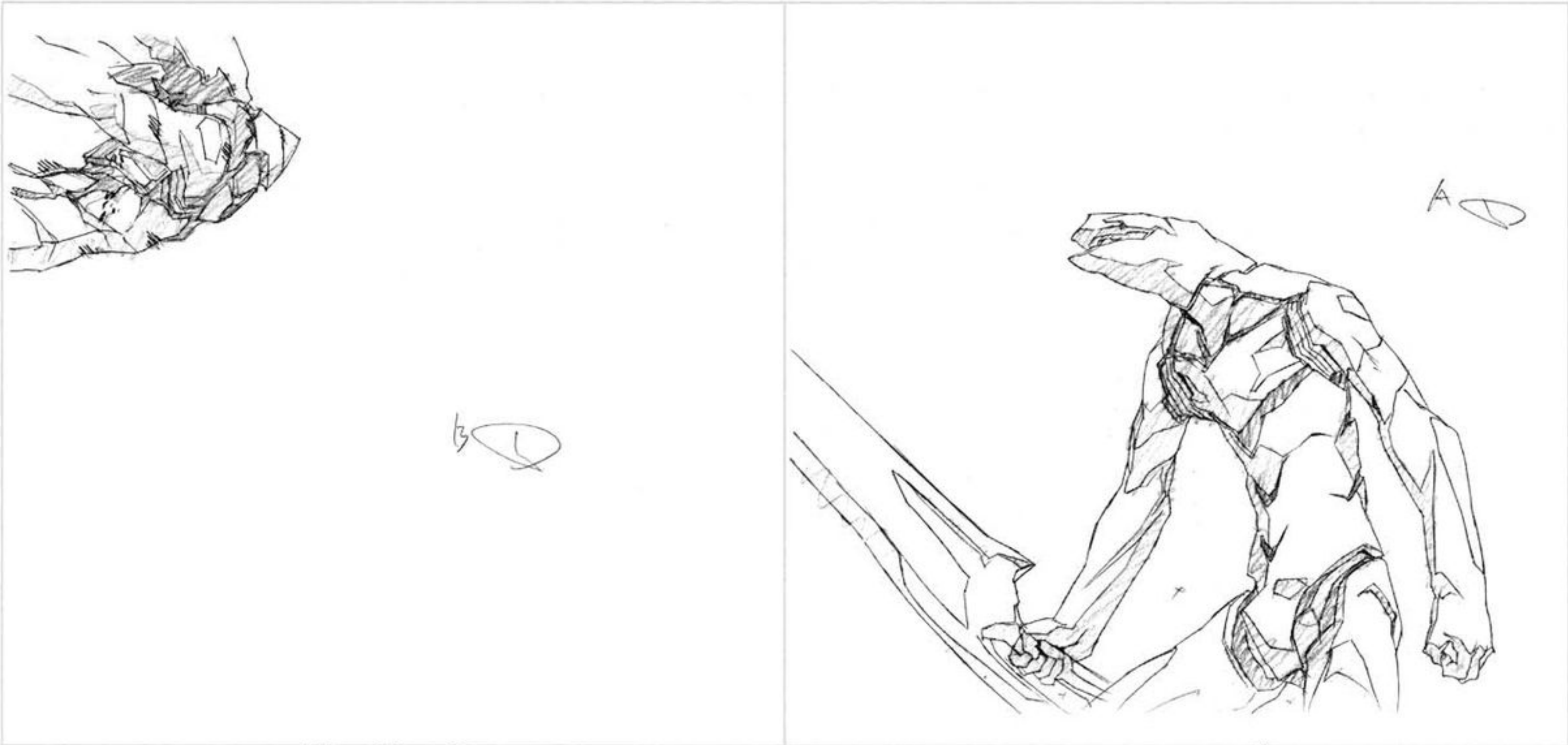



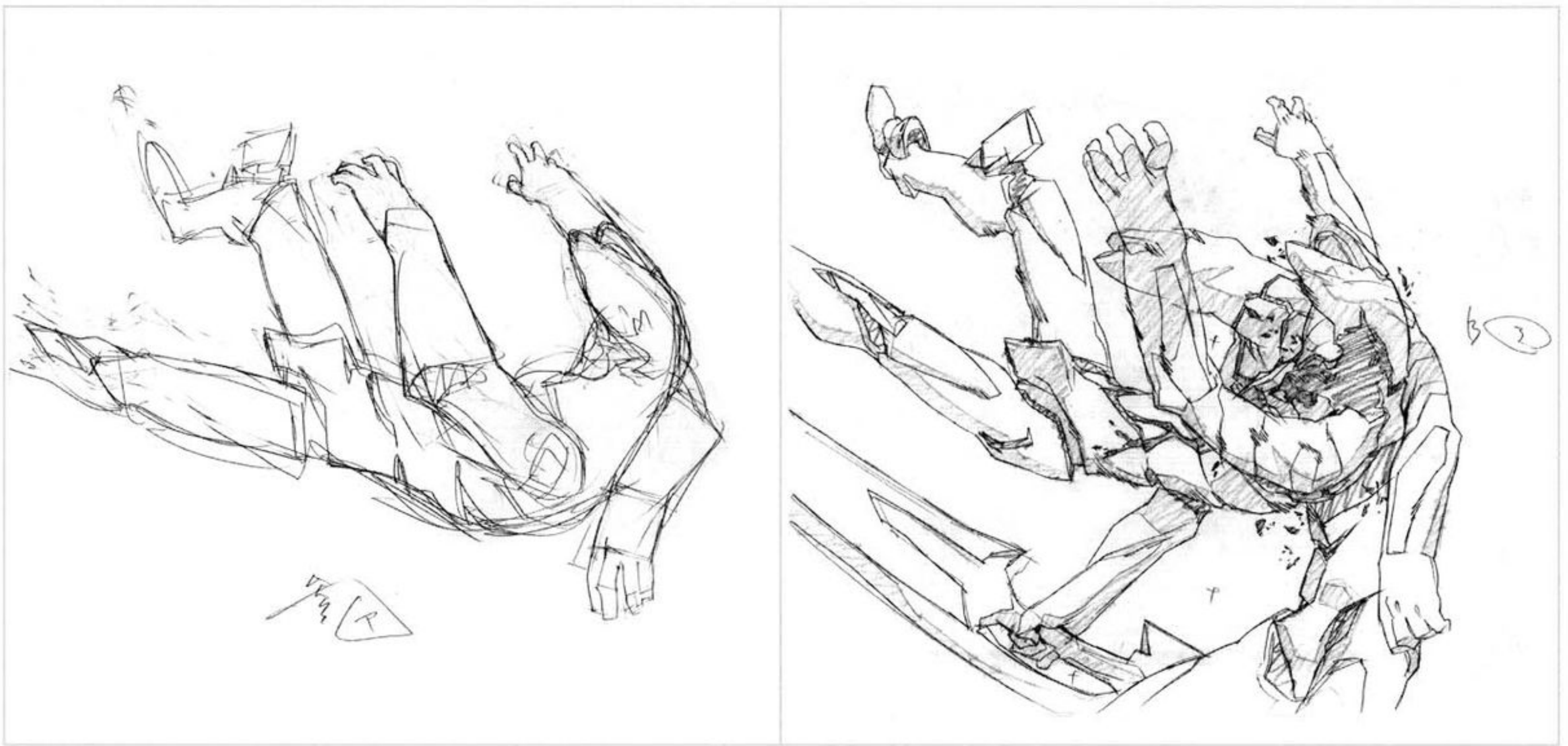









A	b	C	
U	X	X	2
			4
①			6
②			8
X	③		10
④			12
			14
			16
④			18
			20
⑤	⑥		22
⑦			24
④	①		26
	X		28
⑦			30
			32
			34
			36
			38
			40
⑧			42
			44
			46
			48

タイムシート

#25-C516

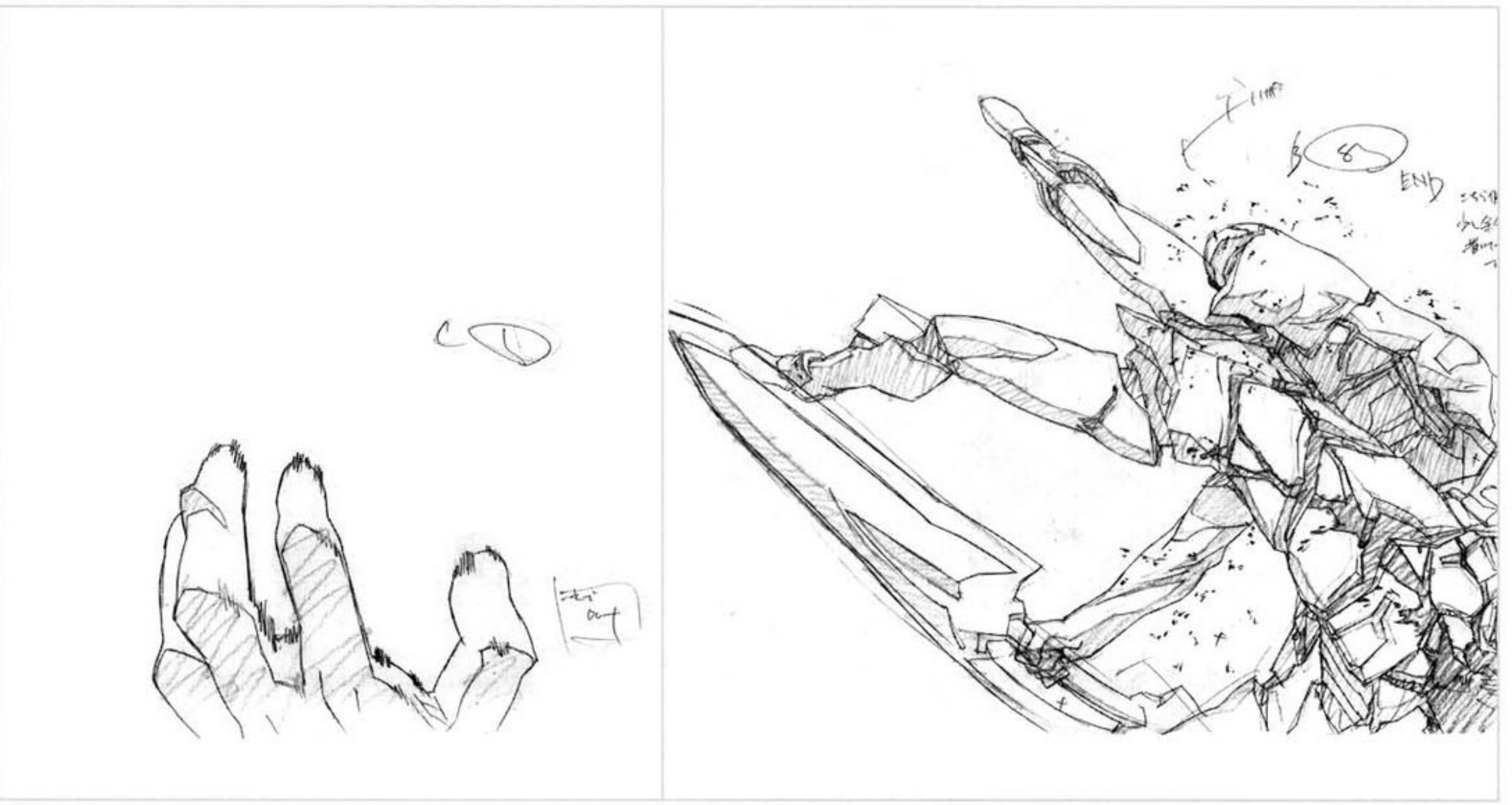



#25-C517

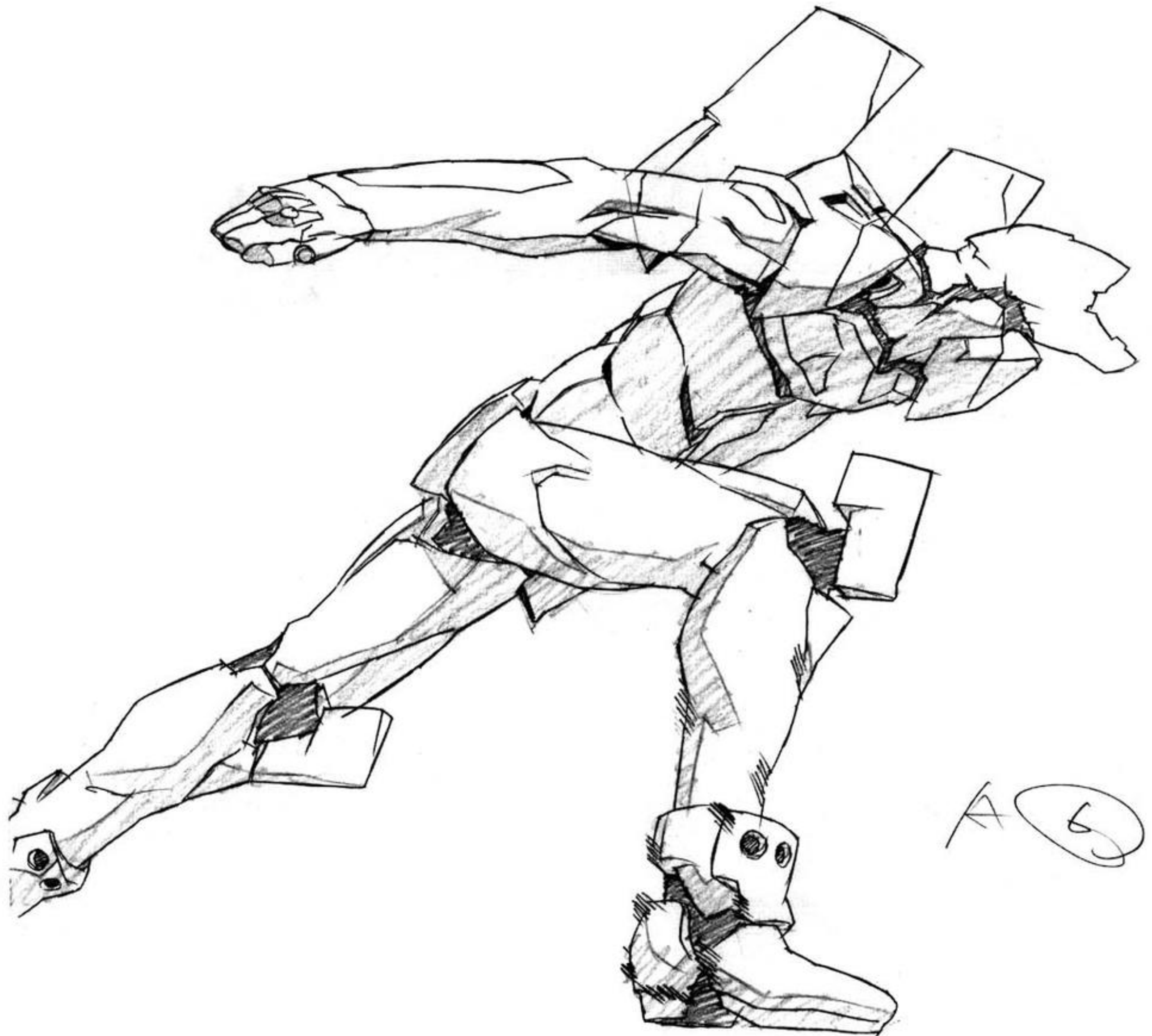
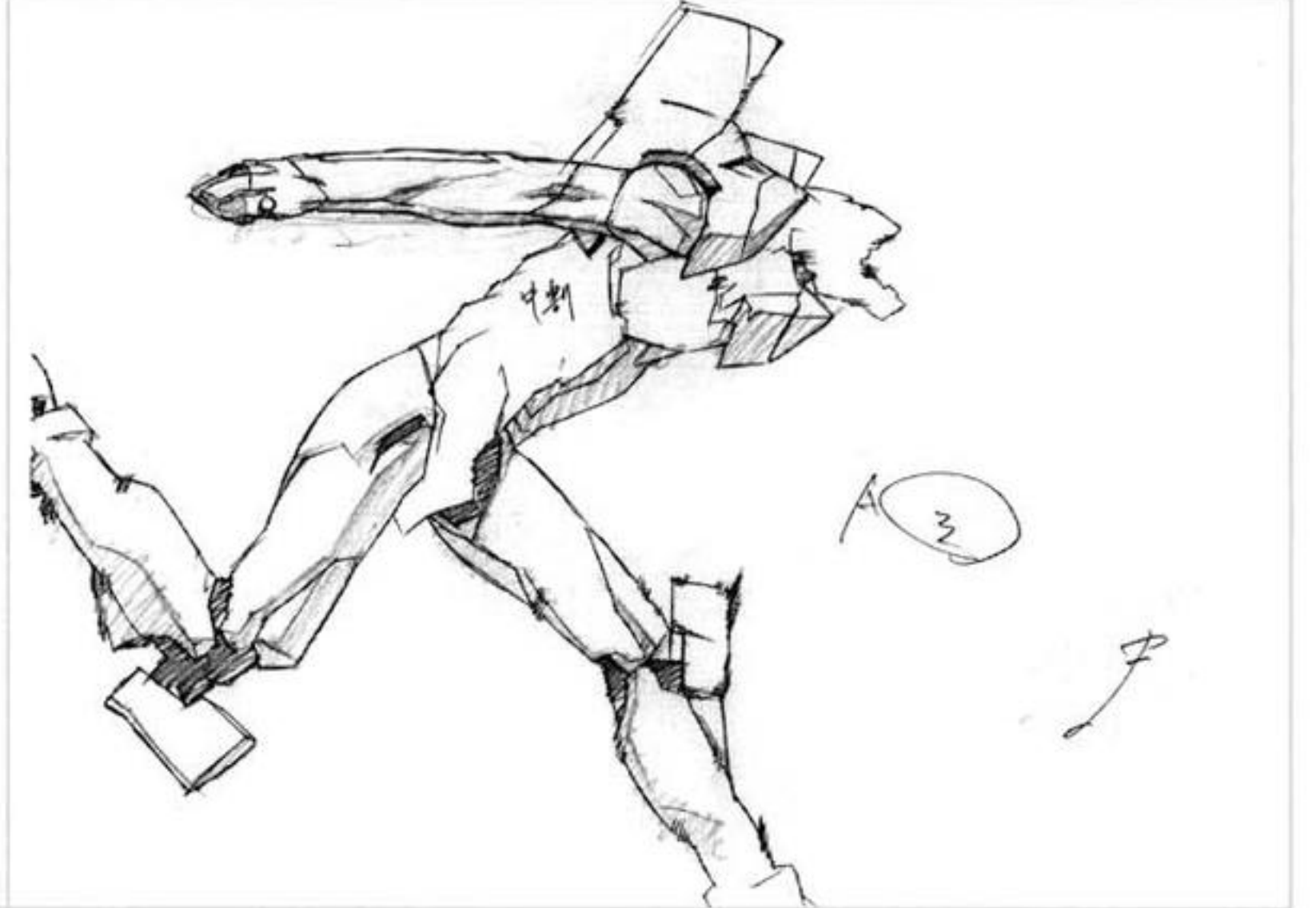
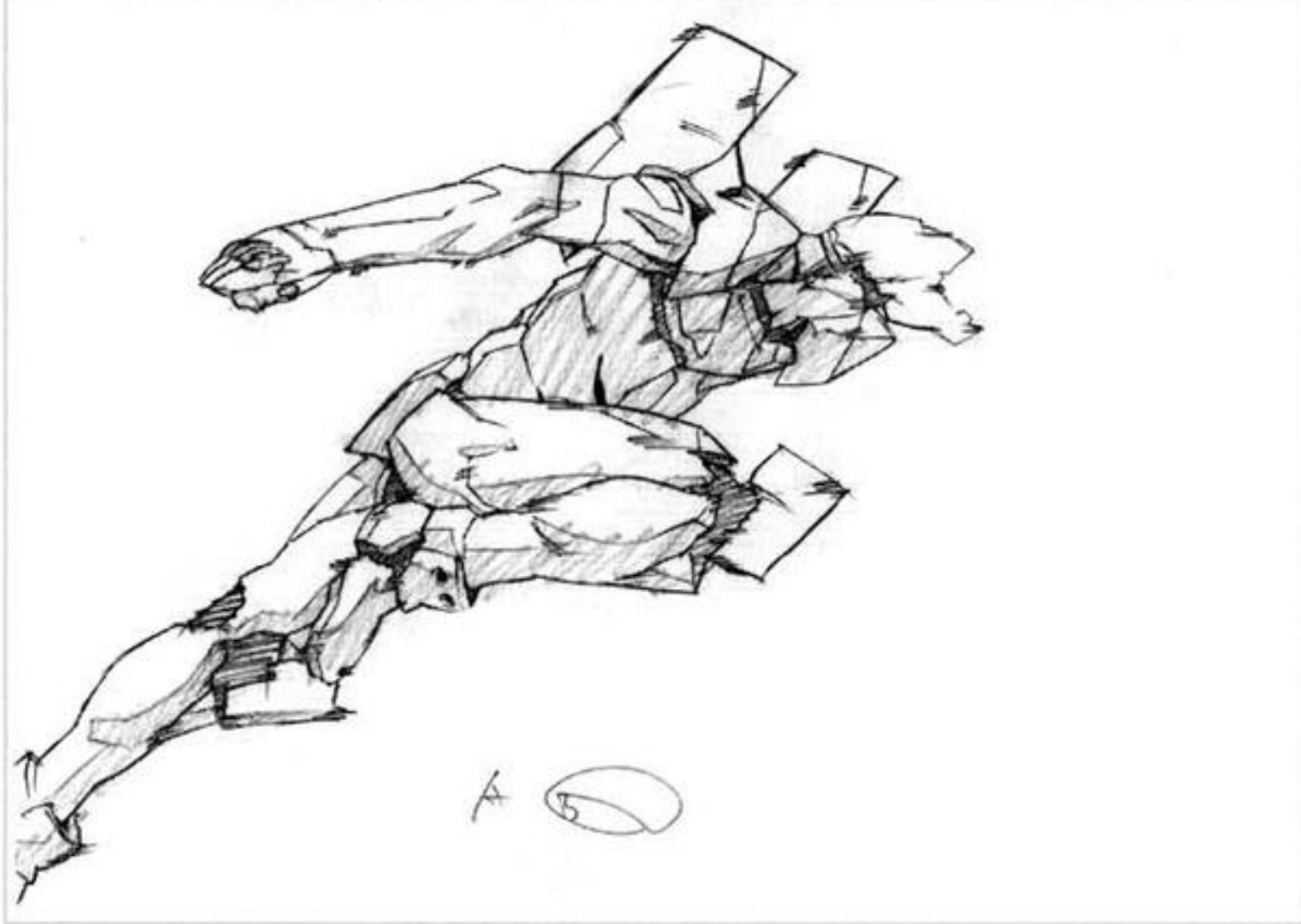
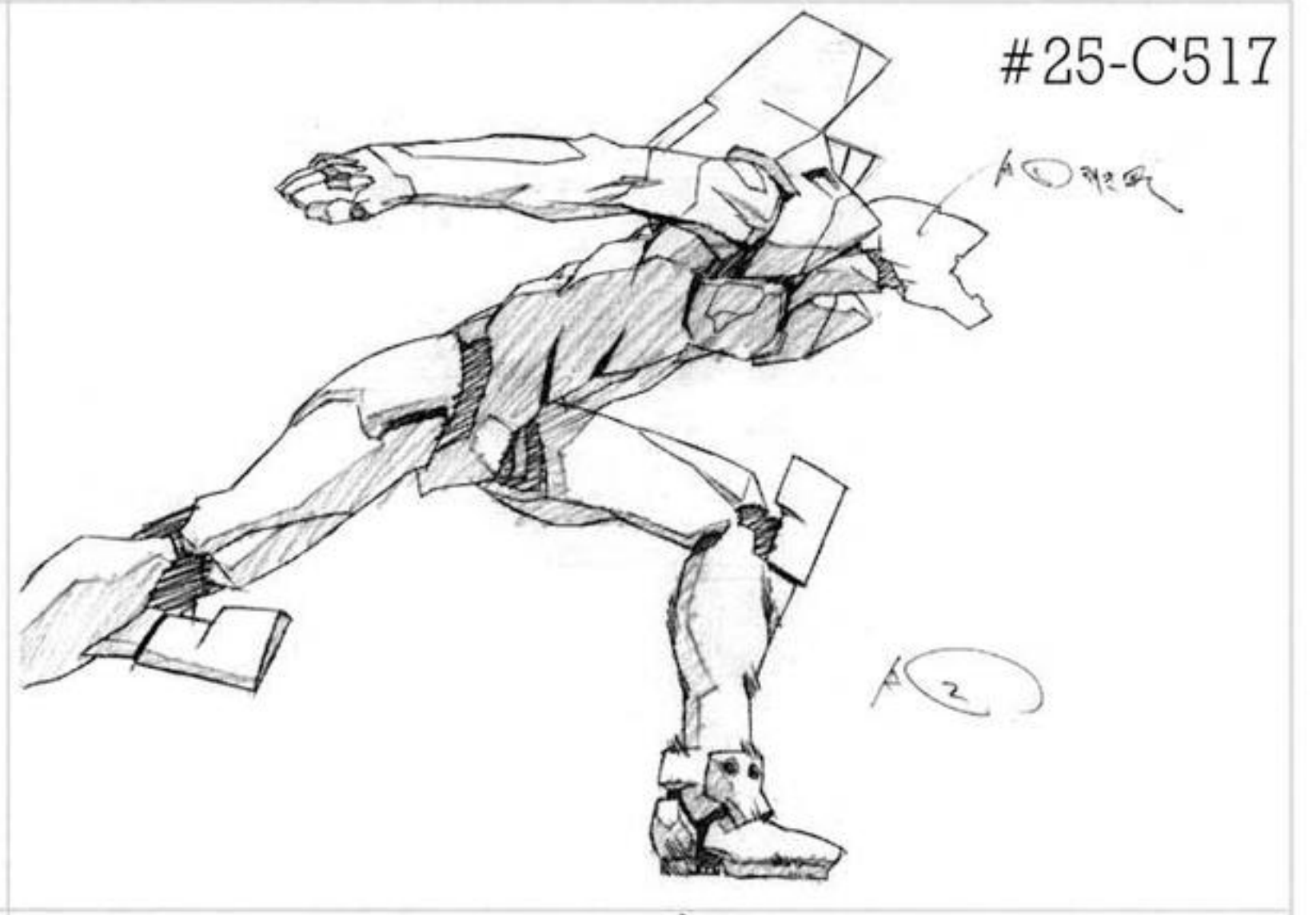
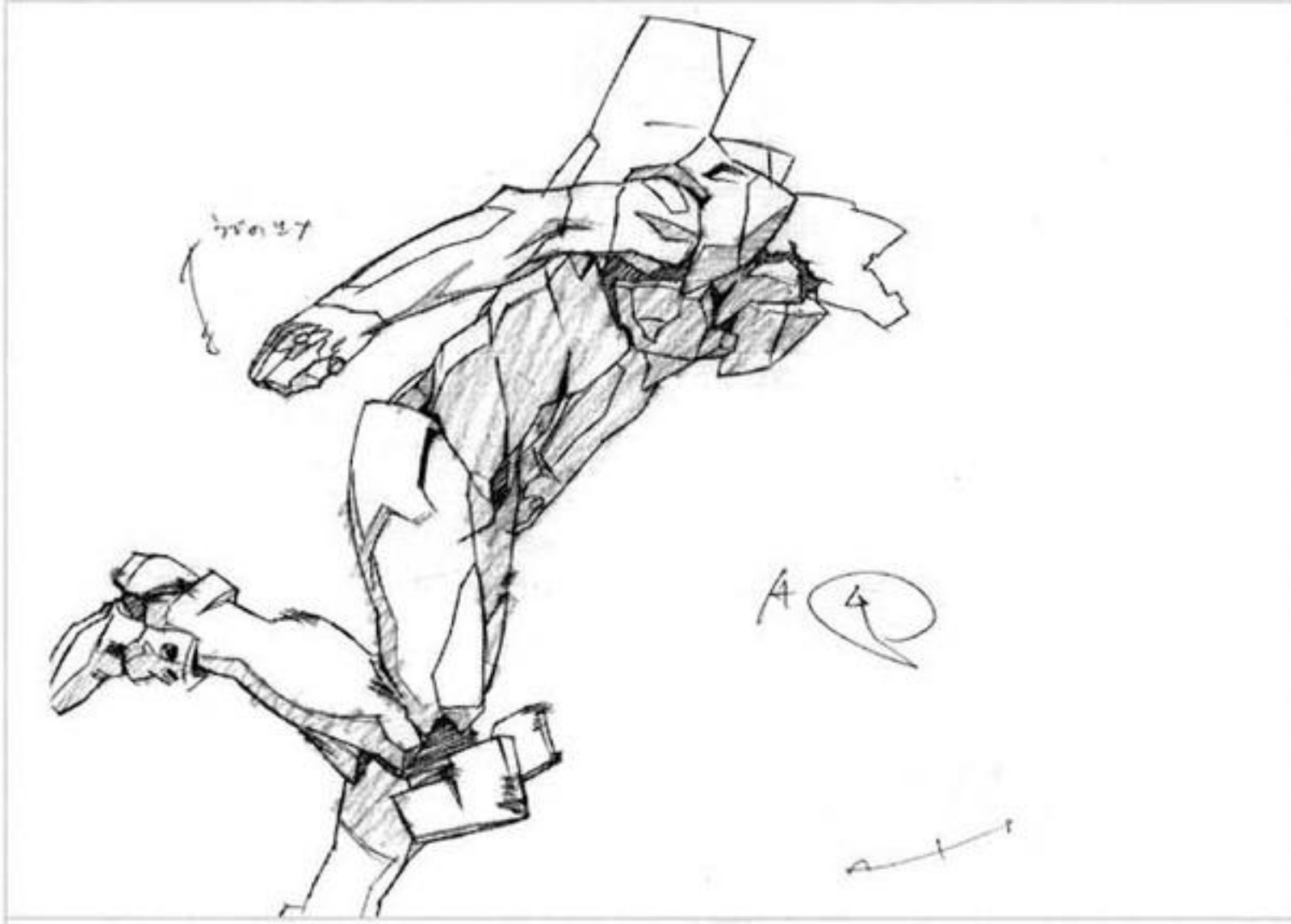









Handwritten annotations including a small cross-like symbol and a triangle with a lightning bolt.



A ①



b ①



A ②

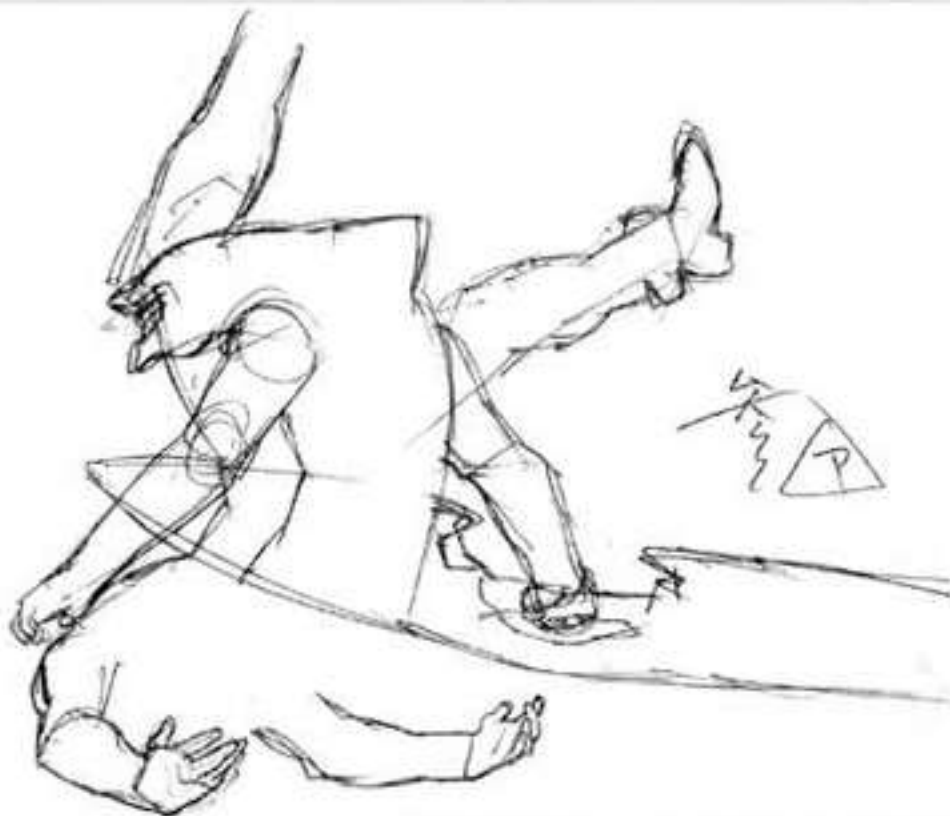

Handwritten annotations including a triangle with a lightning bolt.



A ③



Handwritten annotations including a vertical line with a crossbar.

b ②

Handwritten annotations including a circle with a lightning bolt.



A ④









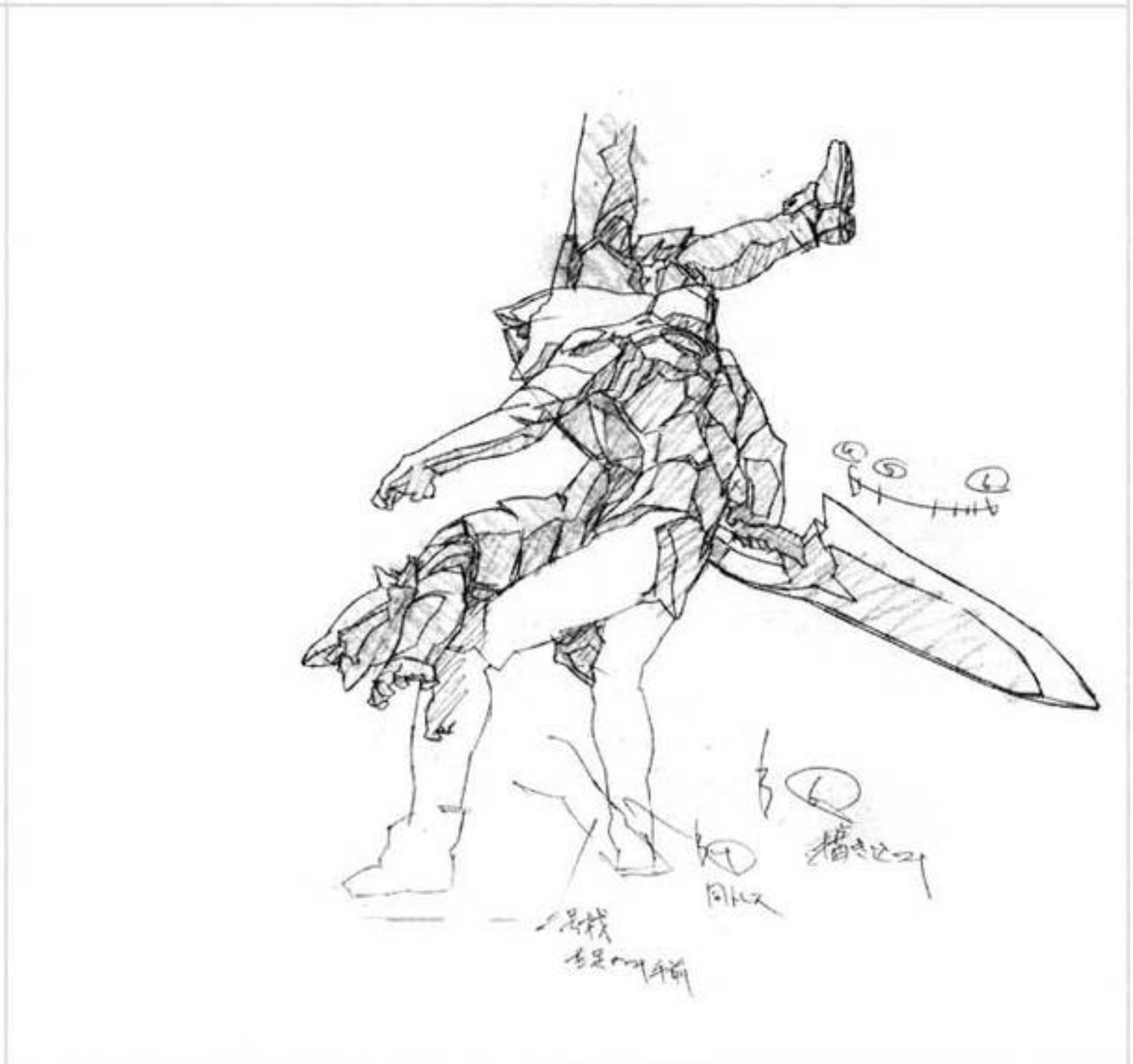
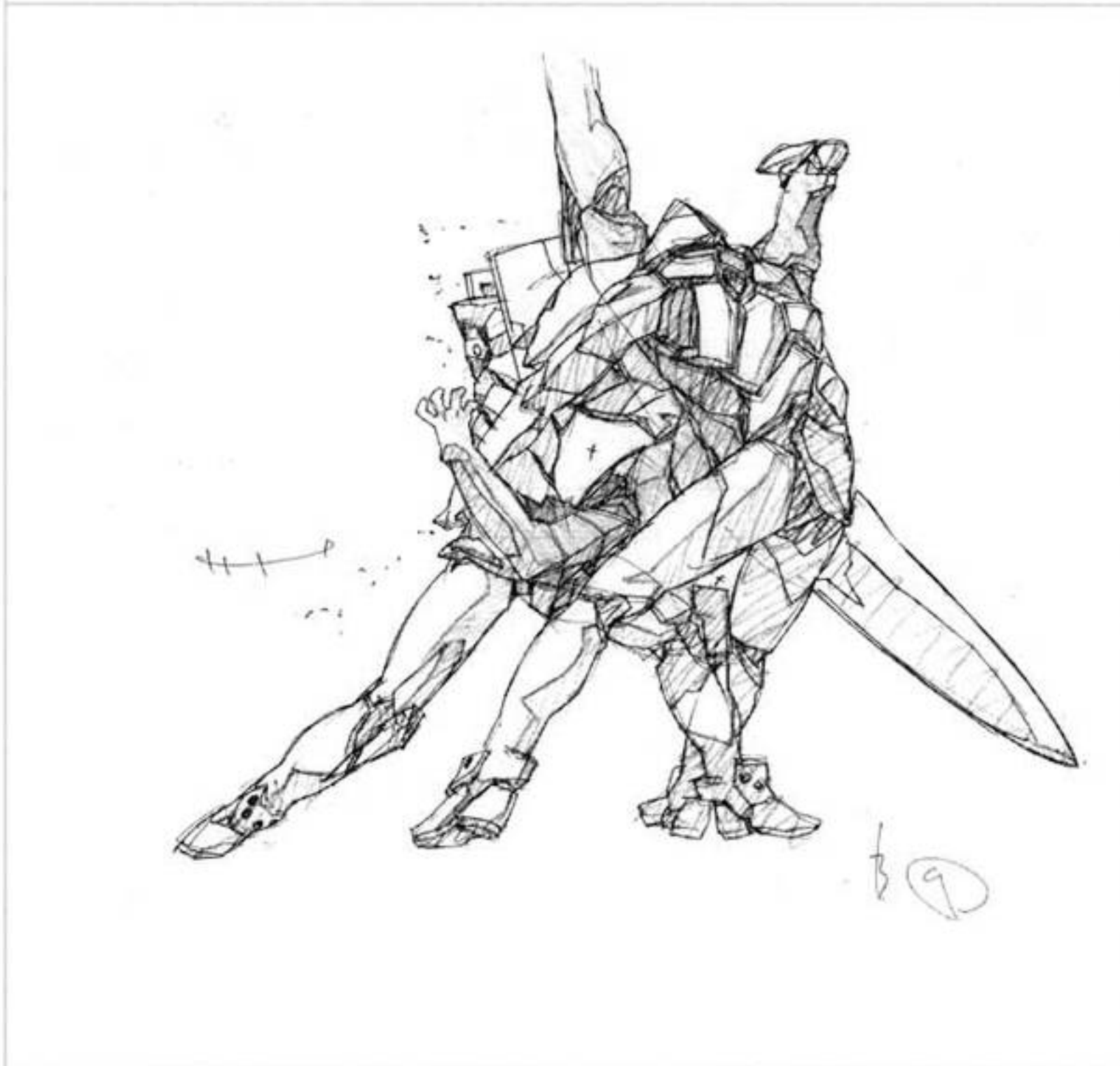
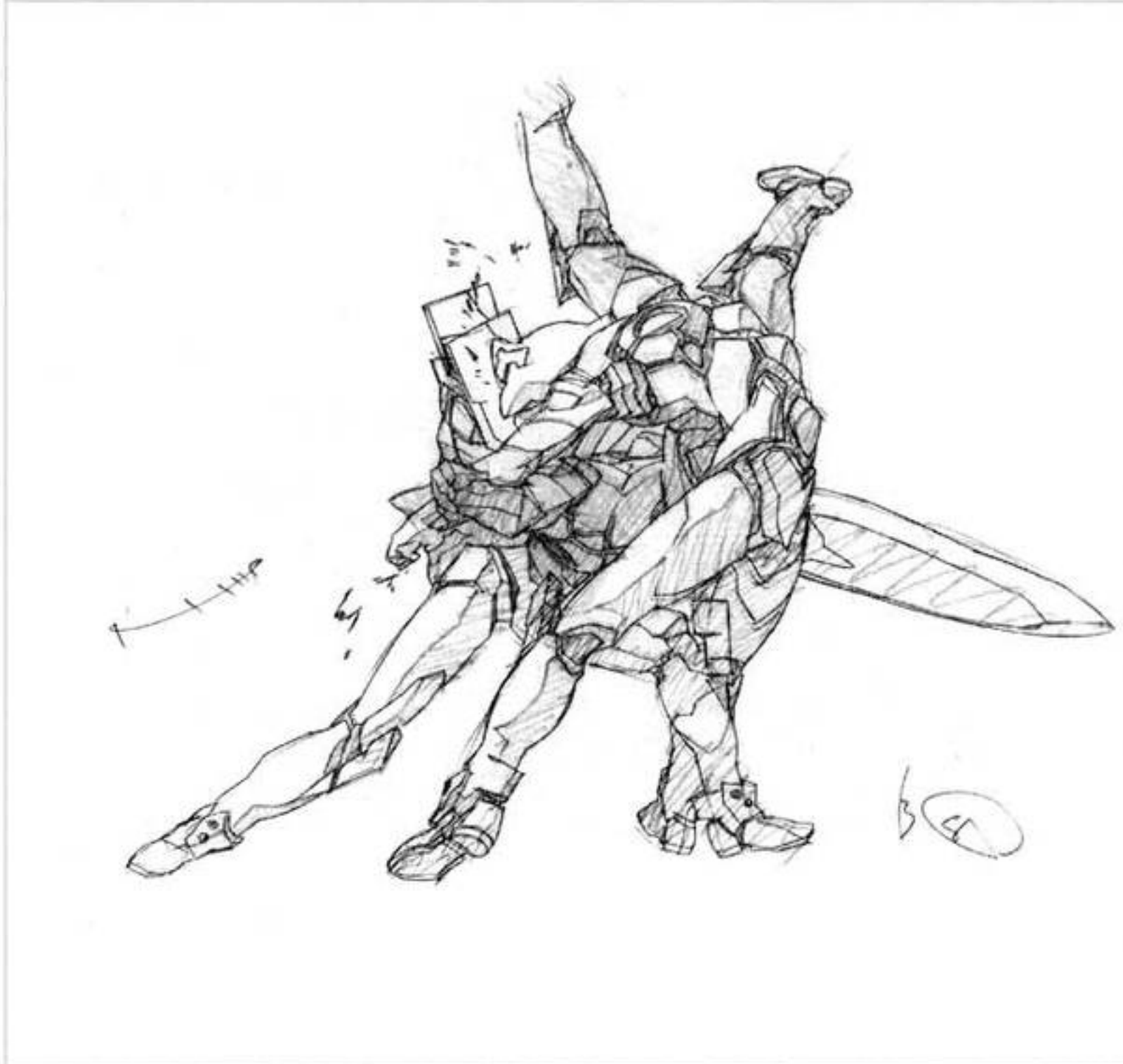
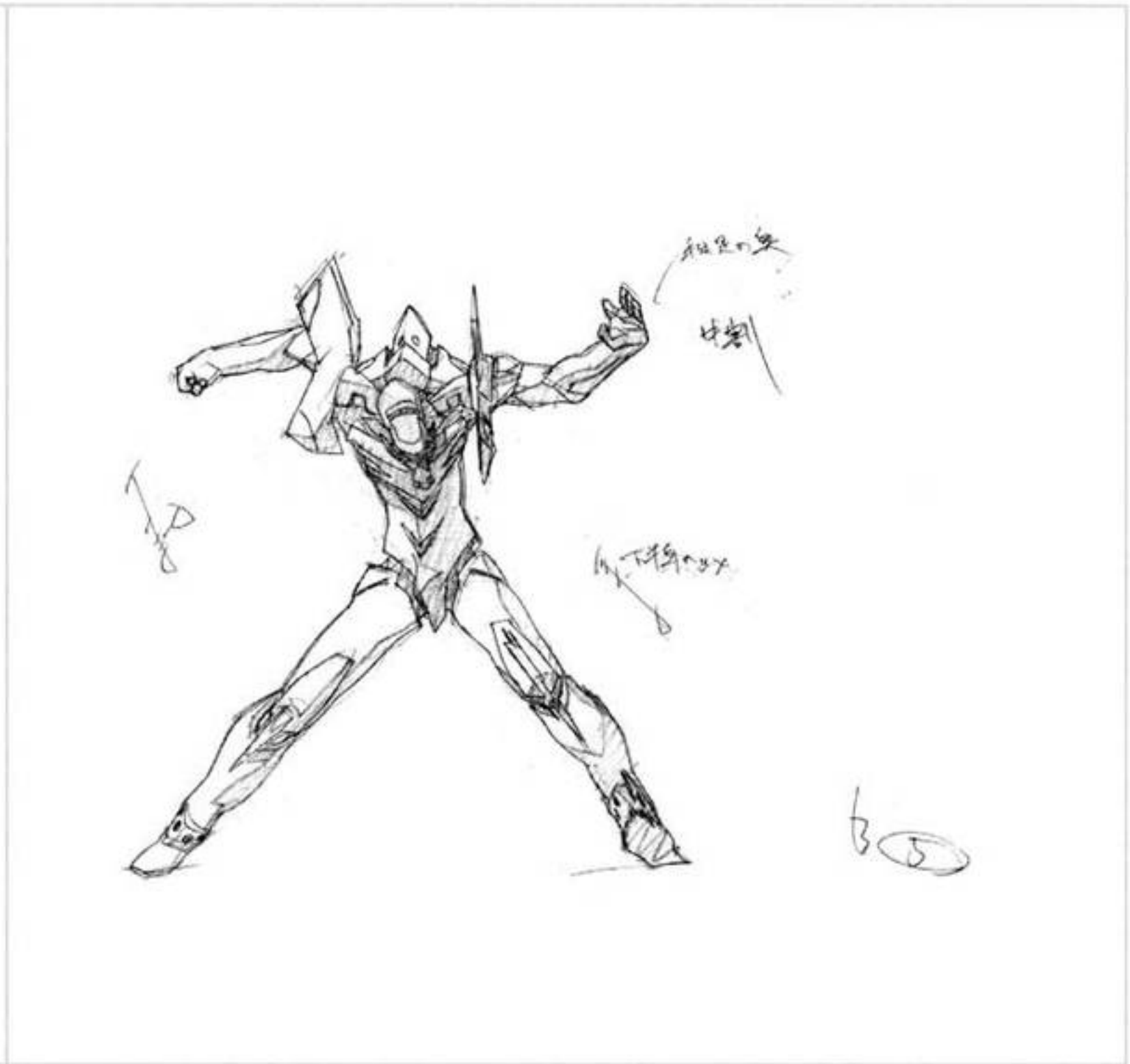
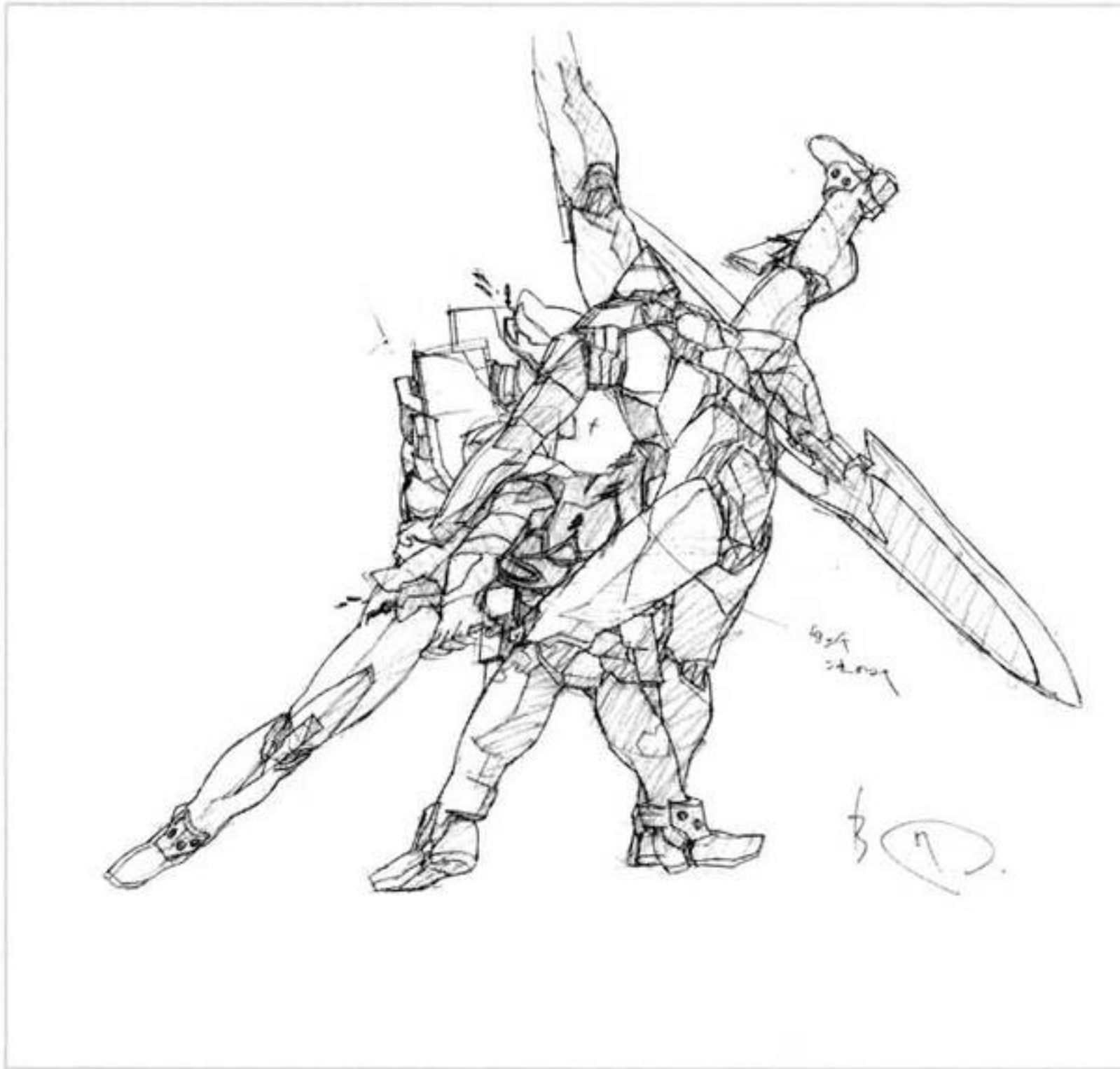





10

A	B	D	
X	①	②	2
		X	4
②			6
	△		8
			10
③			12
			14
④			16
			18
△	③		20
X	③		22
			24

△		26
\		28
\		30
\		32
\		34
④		36
\		38
\		40
\		42
⑤	①	44
\	③	46
\		48

⑥	\	50
⑦	④	52
\	⑤	54
\	\	56
\	⑥	58
\	\	60
⑧	\	62
\	\	64
\	⑦	66
⑨	\	68
\	\	70
△	\	72

\	⑧	74
\	\	76
\	\	78
\	\	80
\	\	82
\	\	84
10	⑨	86

#25-C519  
タイムシート





#25-C520,523

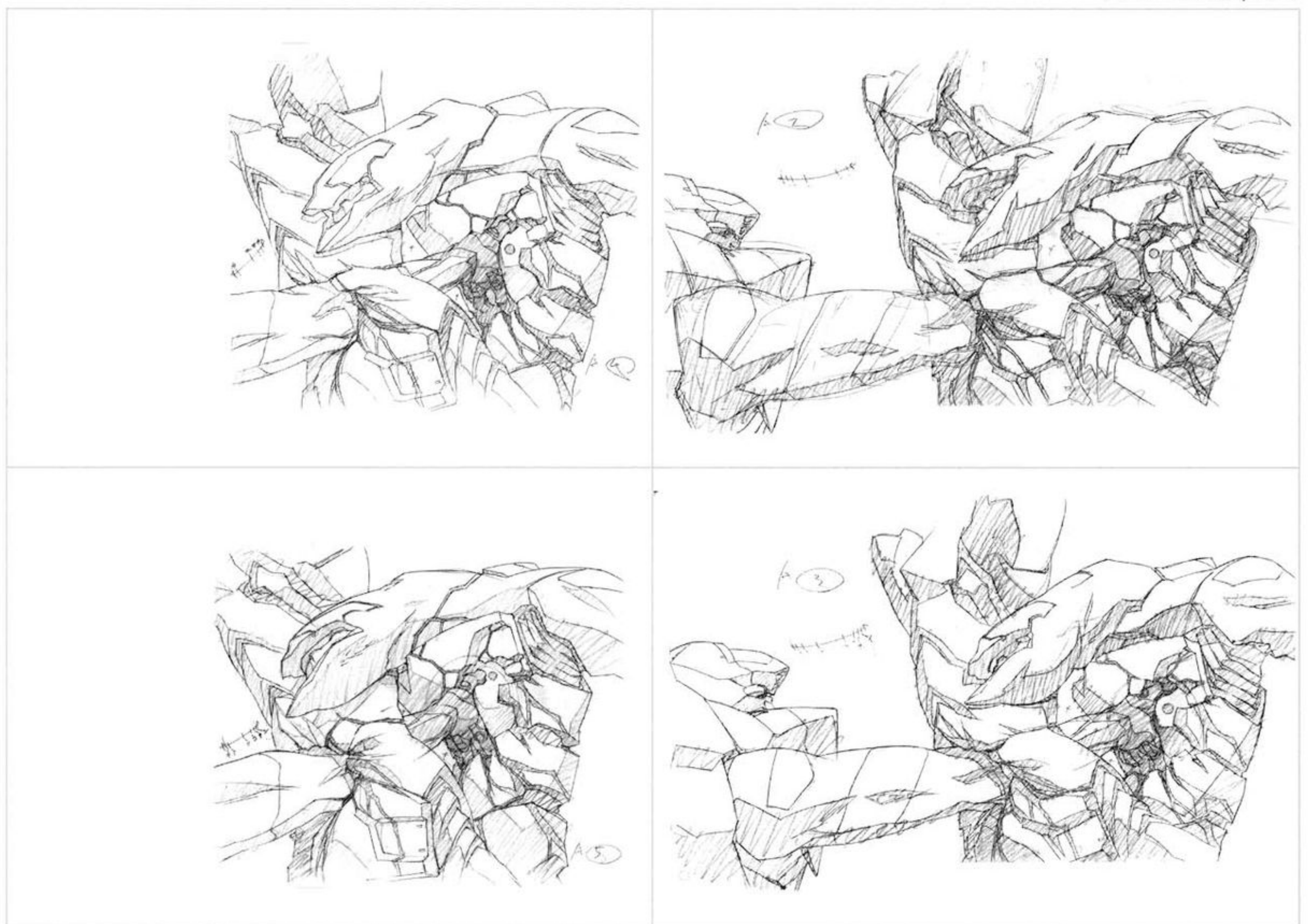



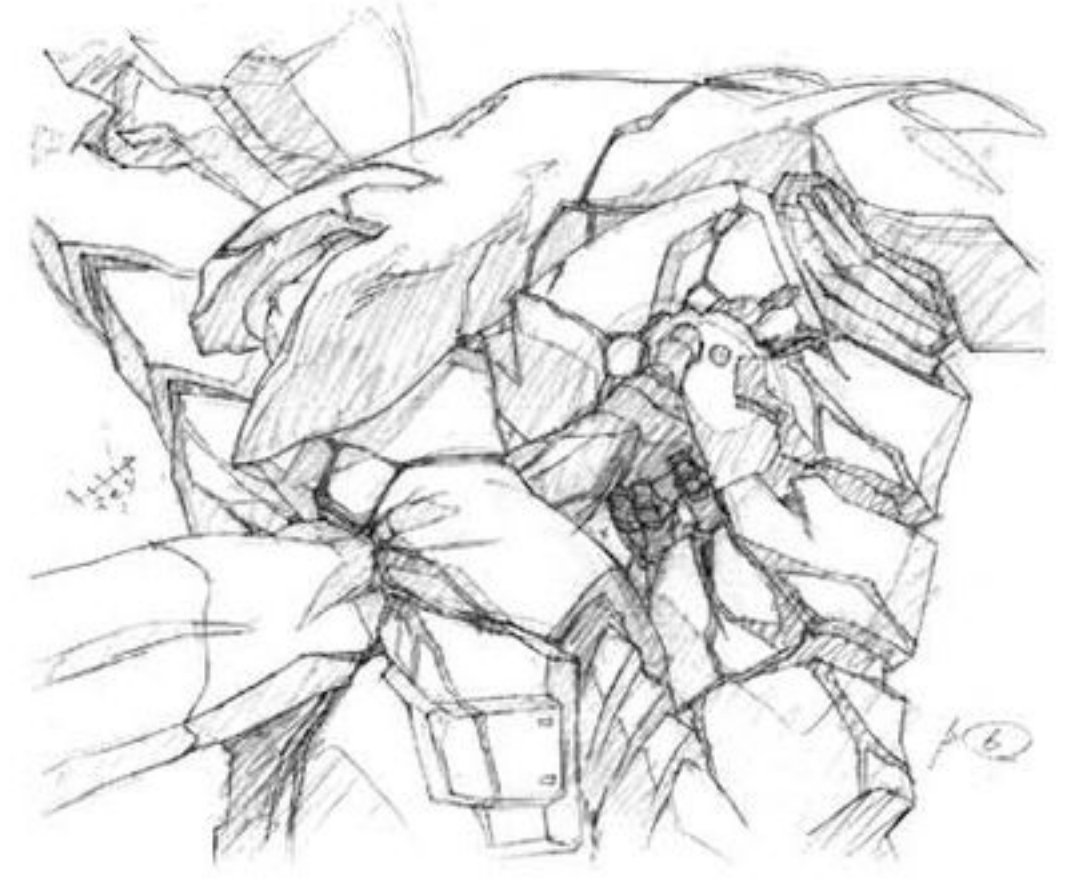
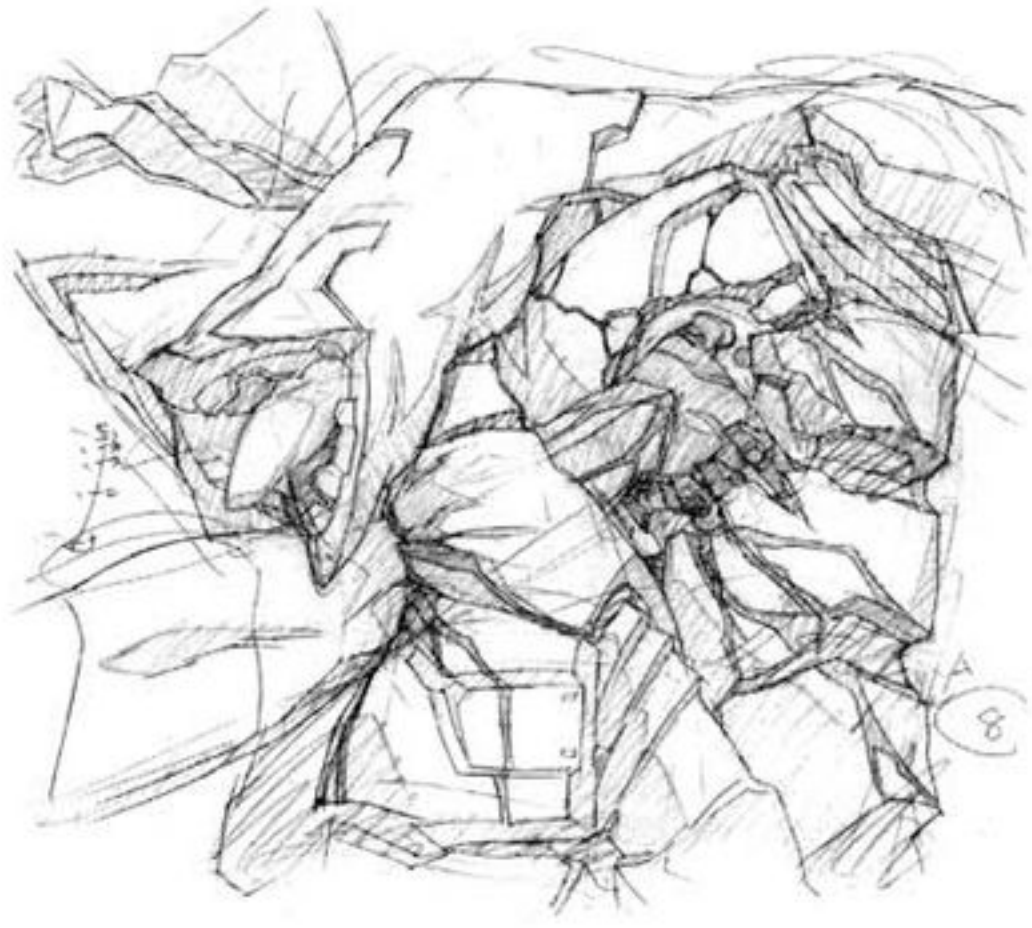





AI 修正

顔のタッチ無しで  
お願ひです



修正原画





A10 修  
↓ 顔の形  
無心  
可憐い

修正原画



A9 修



A15 修

修正原画



A9 修

↓ 顔の形  
無心  
可憐い



A13 修

↓ 顔の形  
無心  
可憐い

修正原画



A10 修



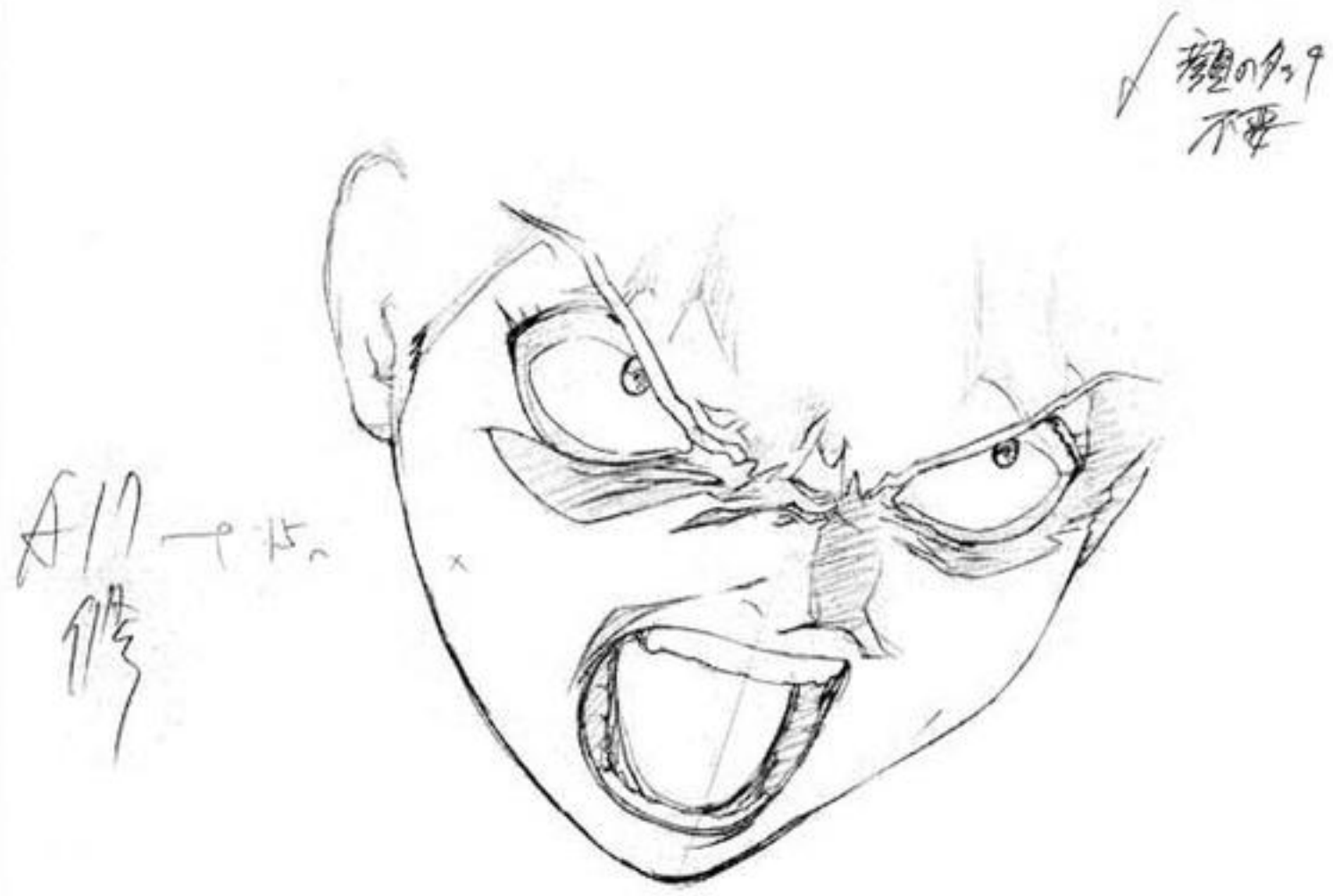

修正原画



修正原画



修正原画







A		
10		2
12		4
11		6
13		8
12		10
14		12
13		14
15		16
14		18
15		20
14		22
15		24
16		26
17		28
18		30
16		32
21		34
19		36
21		38
20		40
15		42
21		44
15		46
20		48

21		50
15		52
21		54
15		56
20		58
15		60
22		62
1		64
1		66
1		68
23		70
1		72

#25-525  
タイムシート



修正原画



(A1)



#25-C527

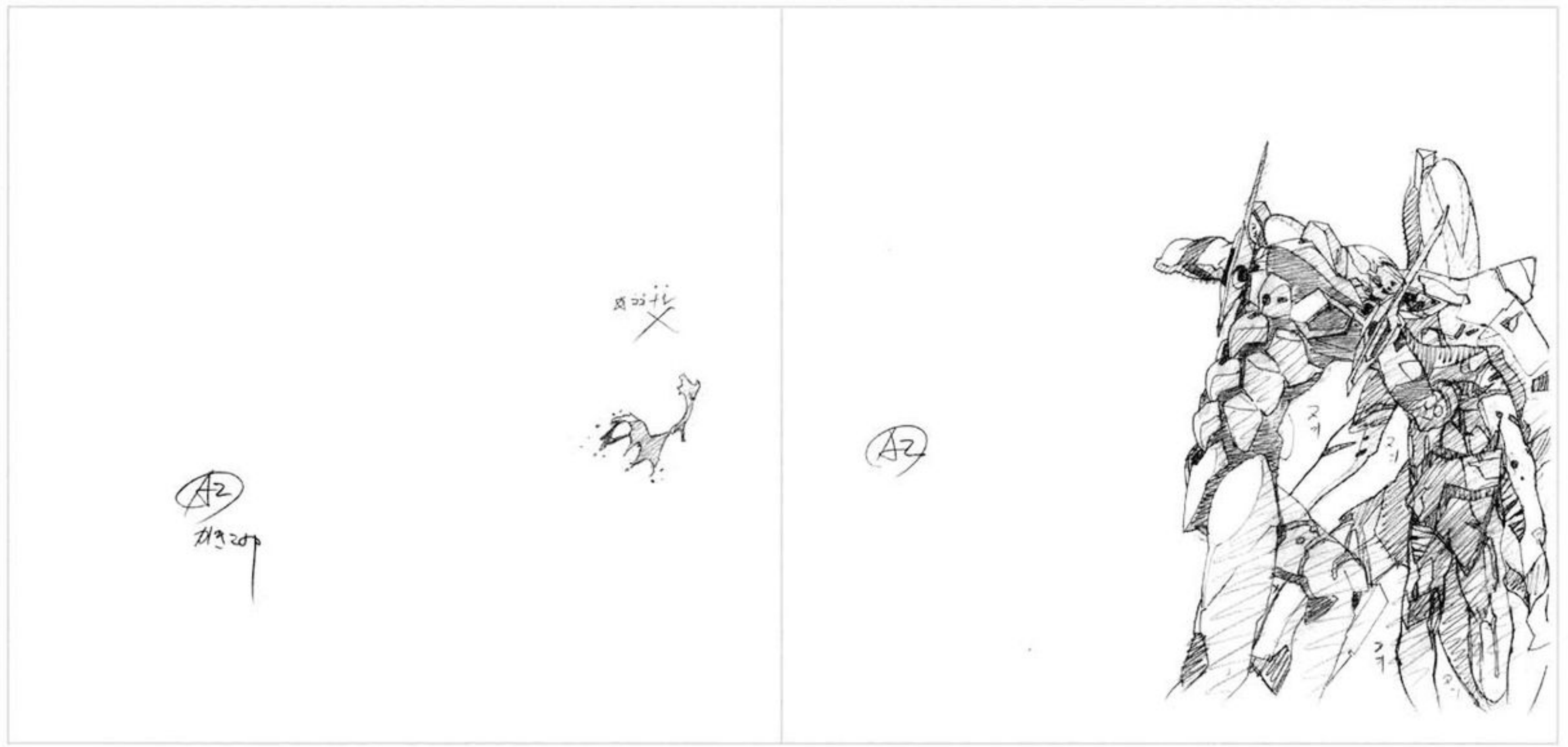



A3  
7/13/2019

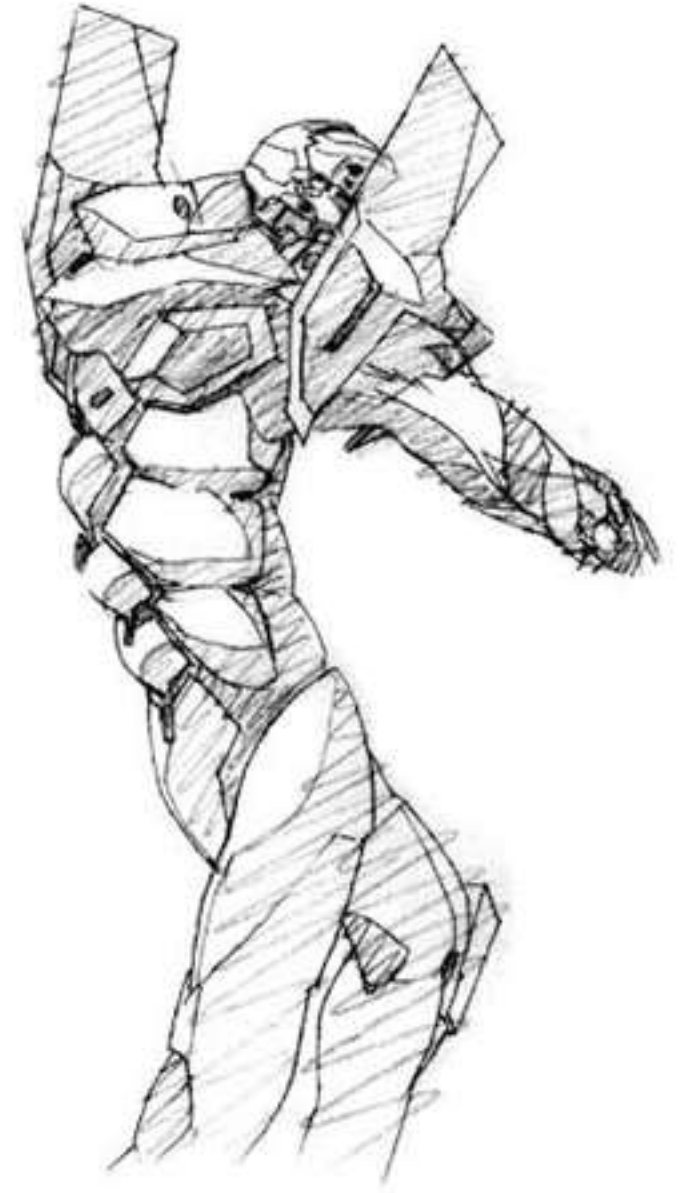

A4

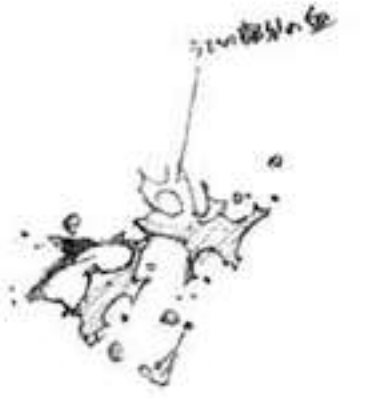

A3  
7/13/2019

A4  
7/13/2019



A3





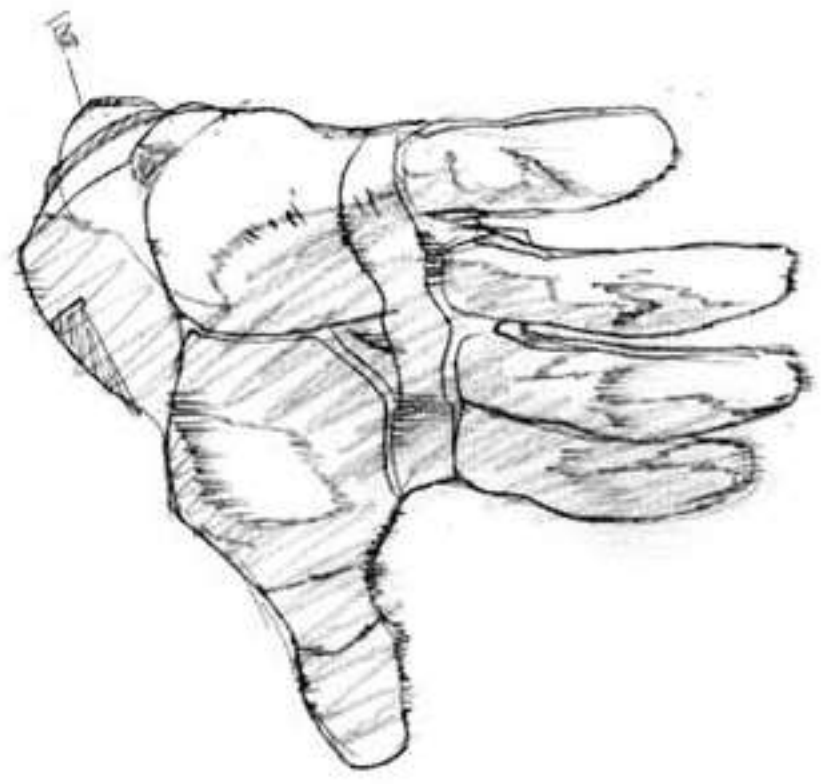

A14



A14

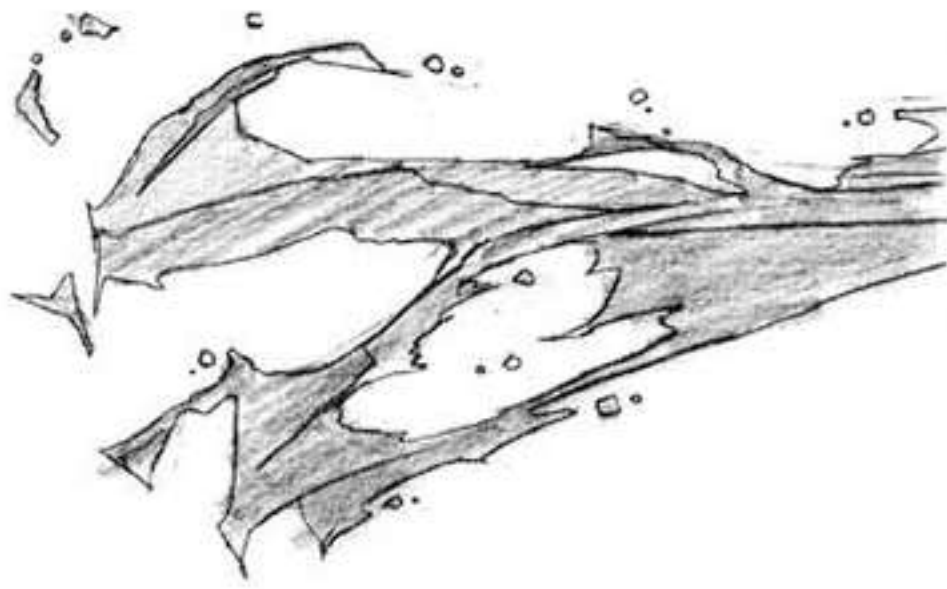

A17  
#1021



A15

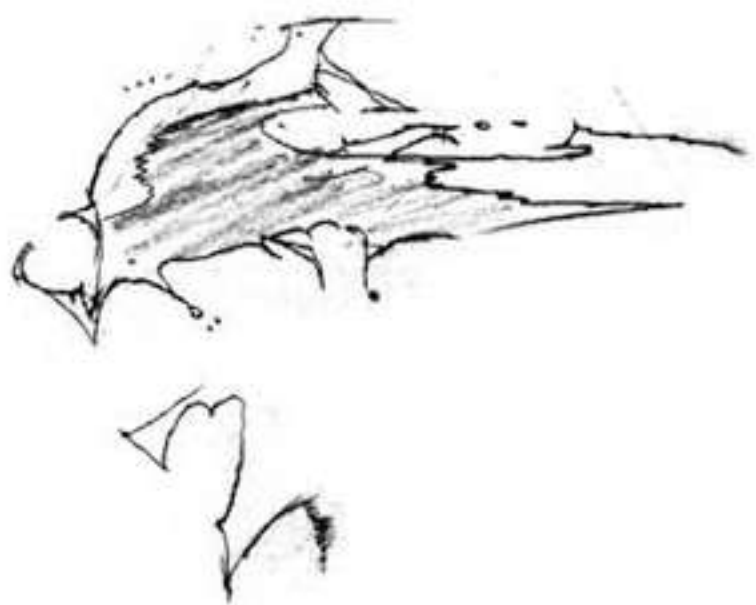

A17  
#1122



A15  
#1227



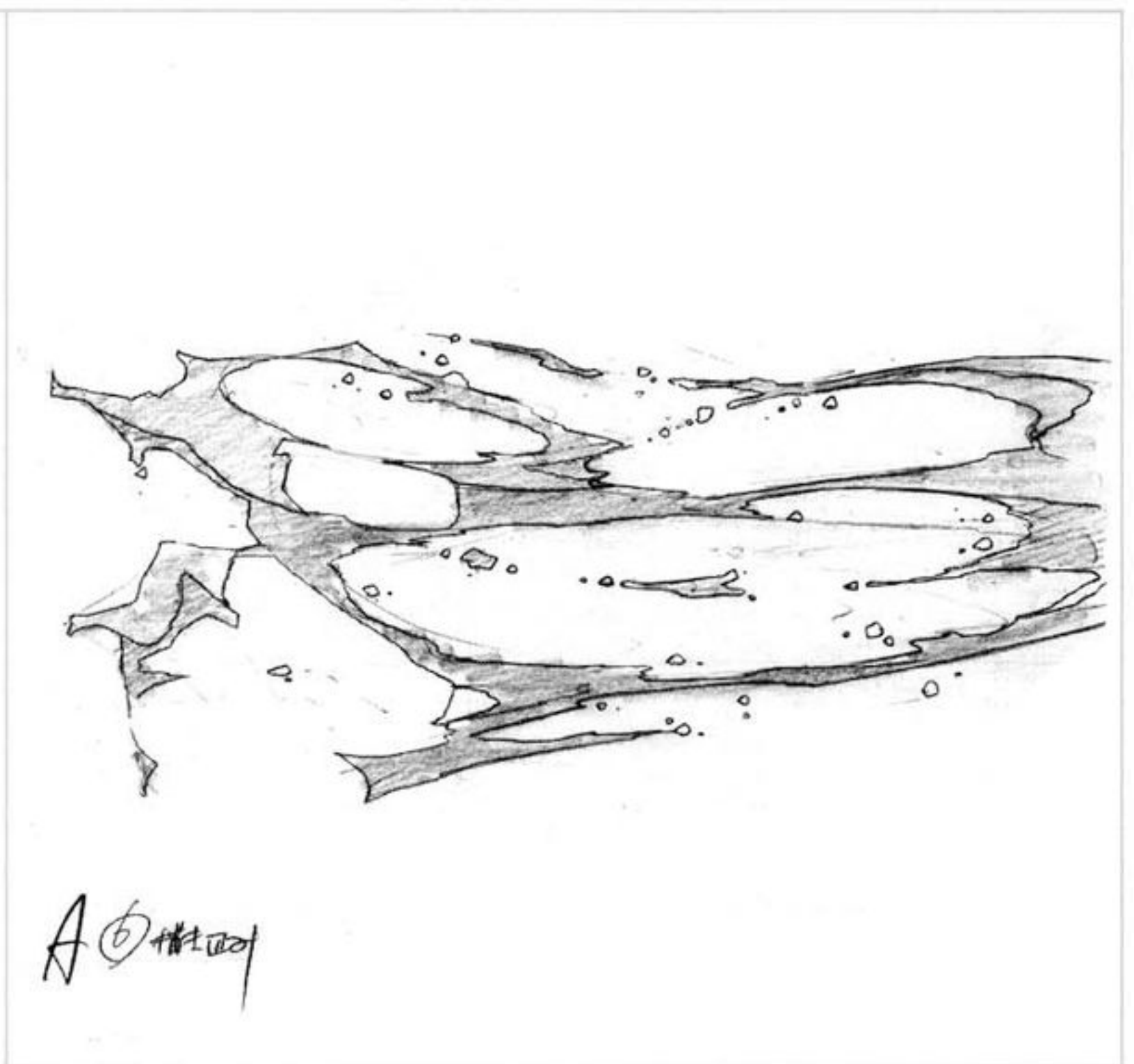
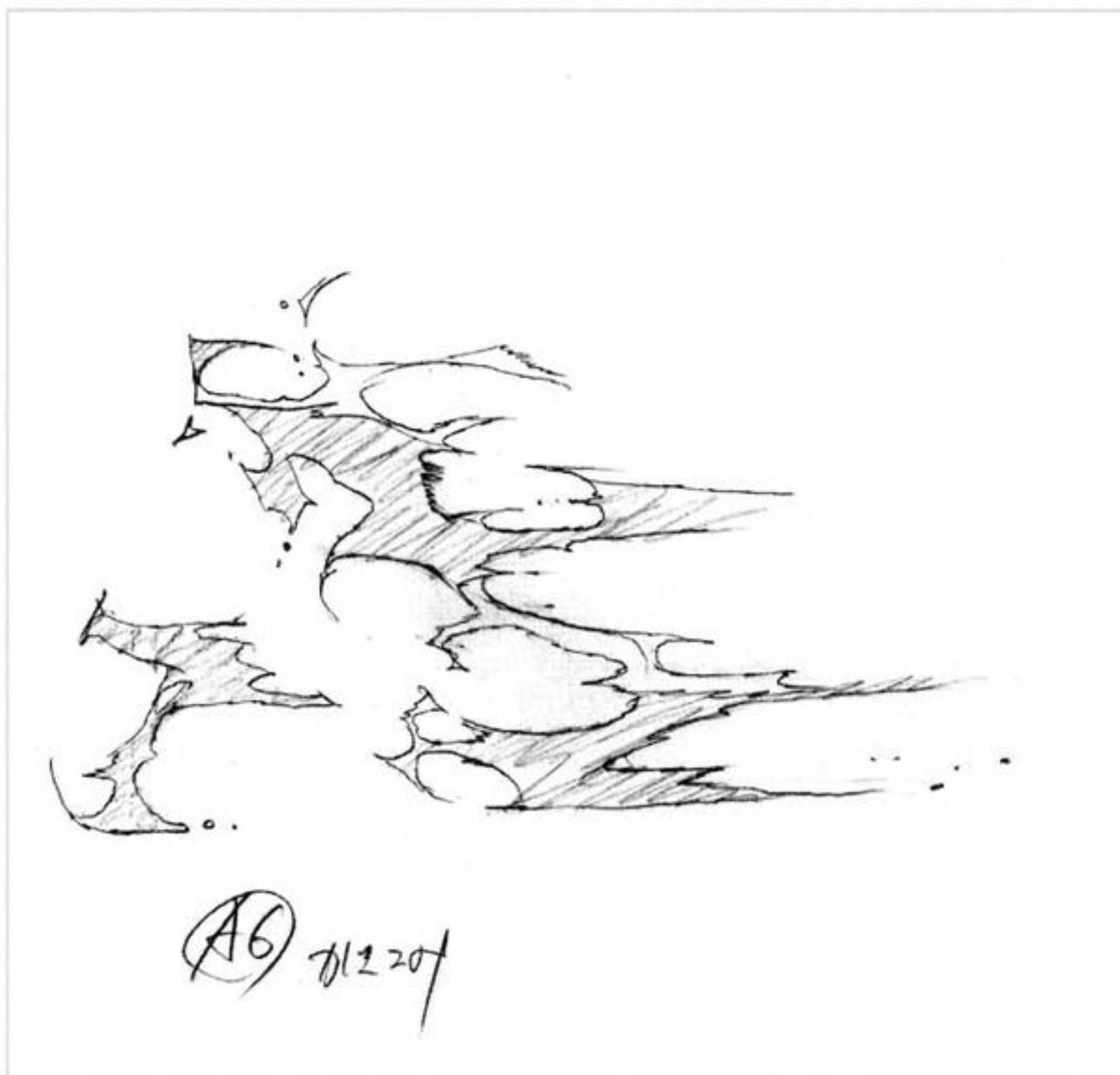



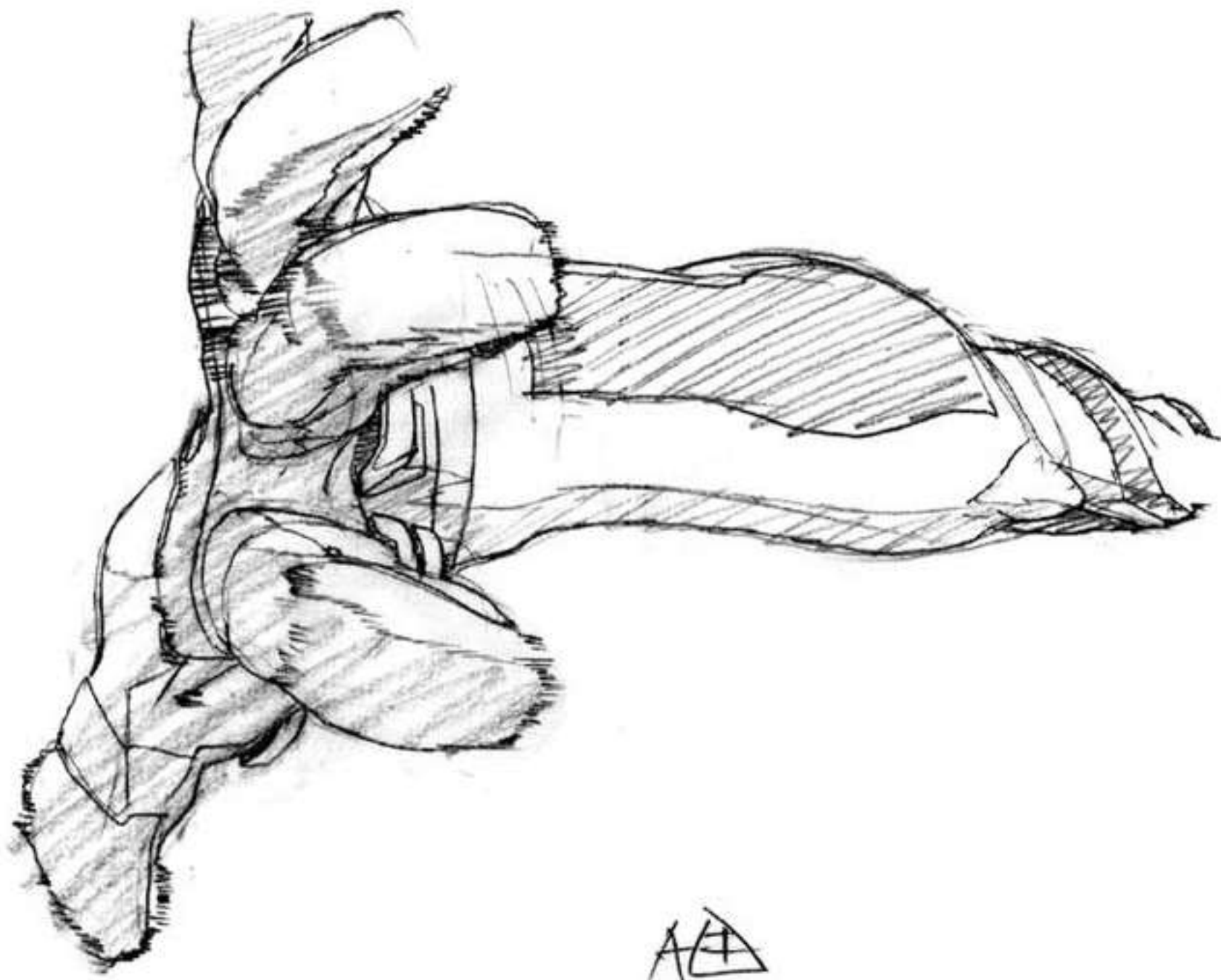

A△

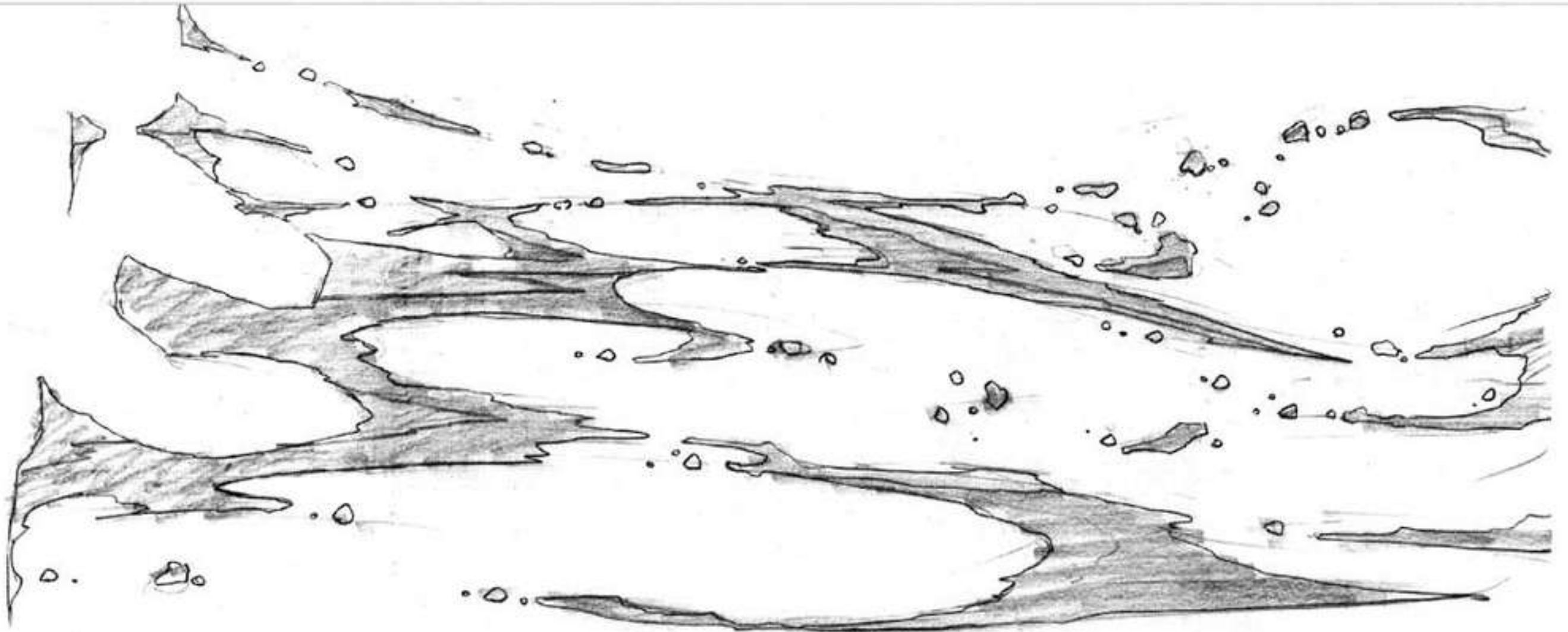

A△ 指地対

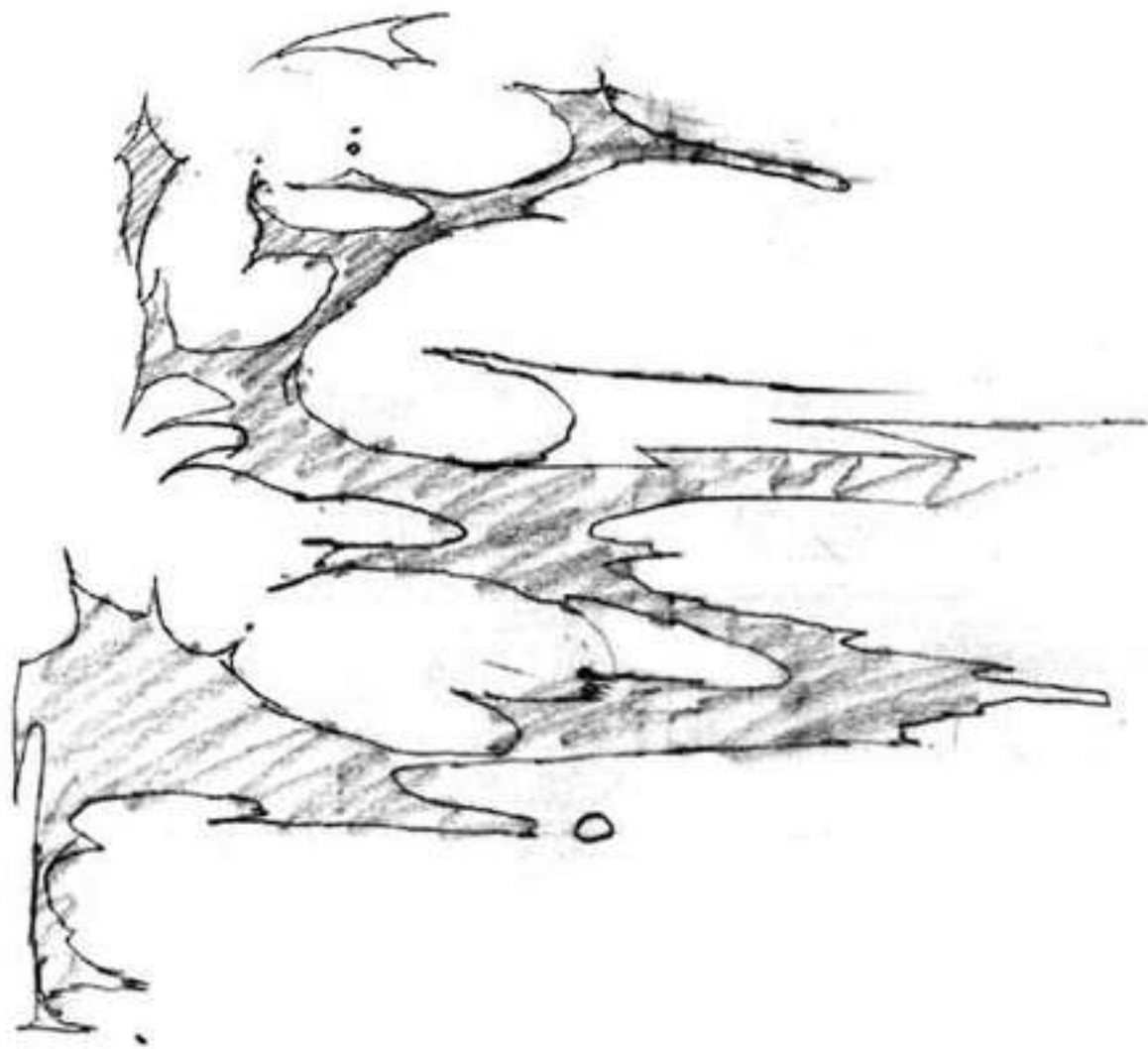

△ I M2 = 01



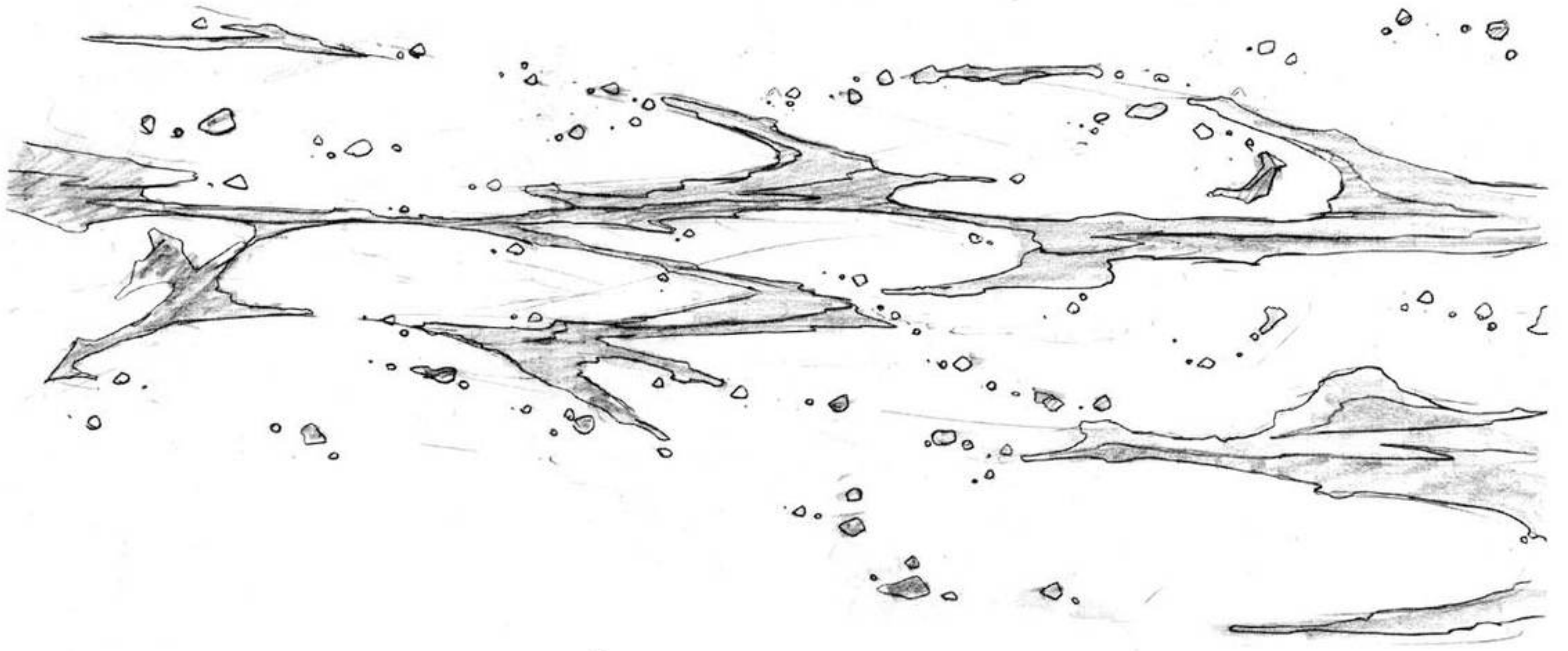
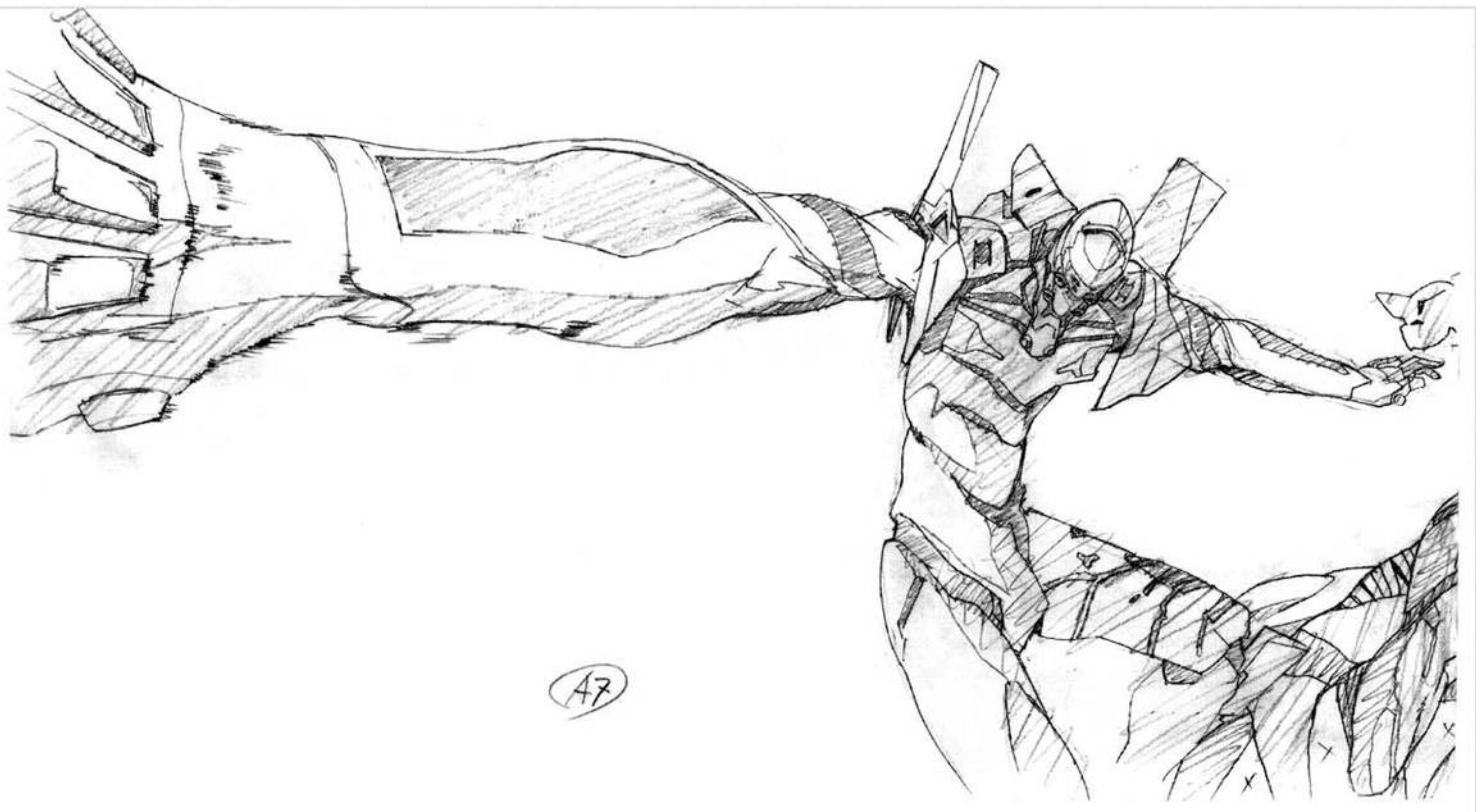

A① 指図

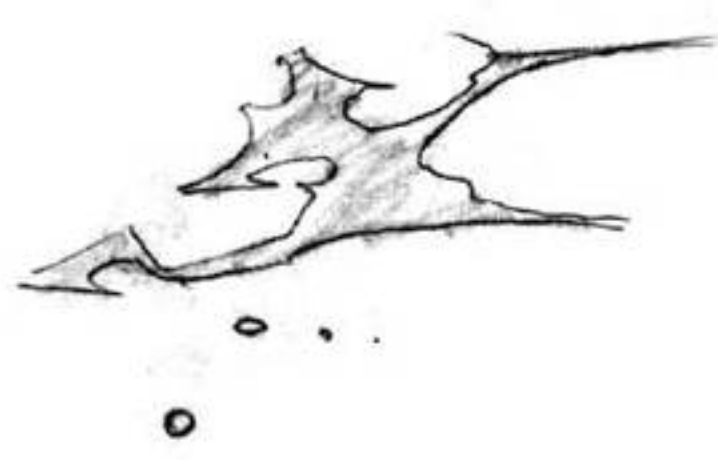

A7 #2204

A	
①	2
✓	4
✓	6
✓	8
②	10
✓	12
③	14
✓	16
④	18
✓	20
⑤	22
⑥	24

⑤	26
⑥	28
⑦	30
⑧	32
⑨	34

#25-C527  
タイムシート





B-1  
17

#25-C529



顔のタイプ  
不要

B-2  
↑

SM  
C-φ  
2  
3





β (2)

AD 007  
k-w



A ①



β (3)

修正原画



①



β (4)



②



β (5)

修正原画



B ①

k-w 007-08



A	B	C	D	E	
X	X	X	X	X	
					2
					4
					6
					8
					10
					12
①	X	X	X		14
					16
					18
					20
					22
					24
②	①	⑤			26
①	①	②	⑥		28
①	③				30
②	④				32
③	⑤	X	①		34
④	⑥				36
X	⑦	②			38
X	⑧	③			40
⑧	⑧				42
⑨					44
④	⑦				46
					48
					50
					52
⑤					54
					56
					58
X					60
					62
					64
					66
					68
					70
					72

タイムシート



↓②



β⑥

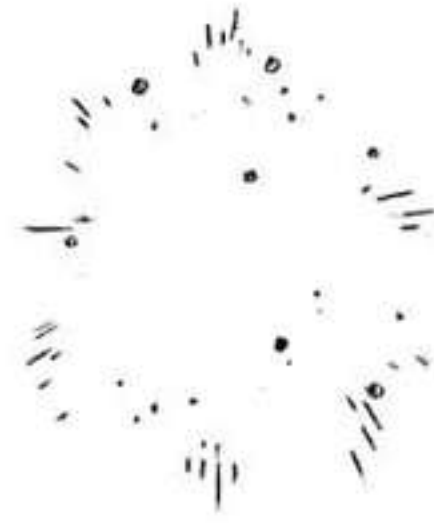

↓③

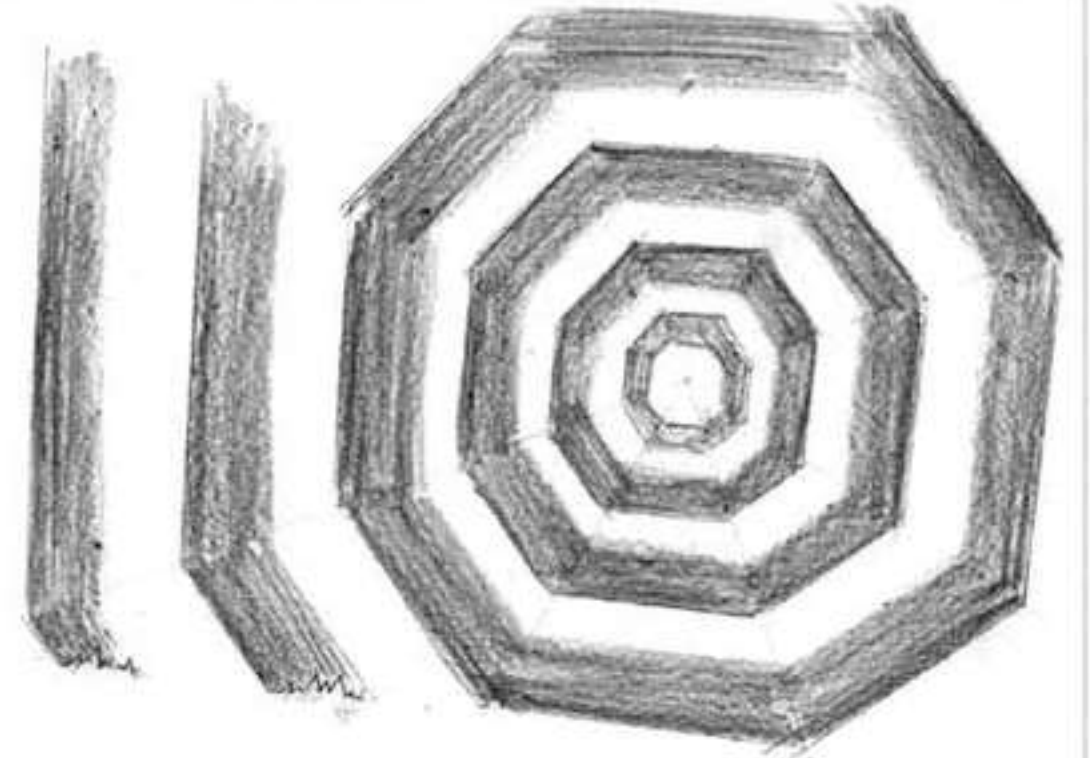

β⑦



↓④ END

#25-C528

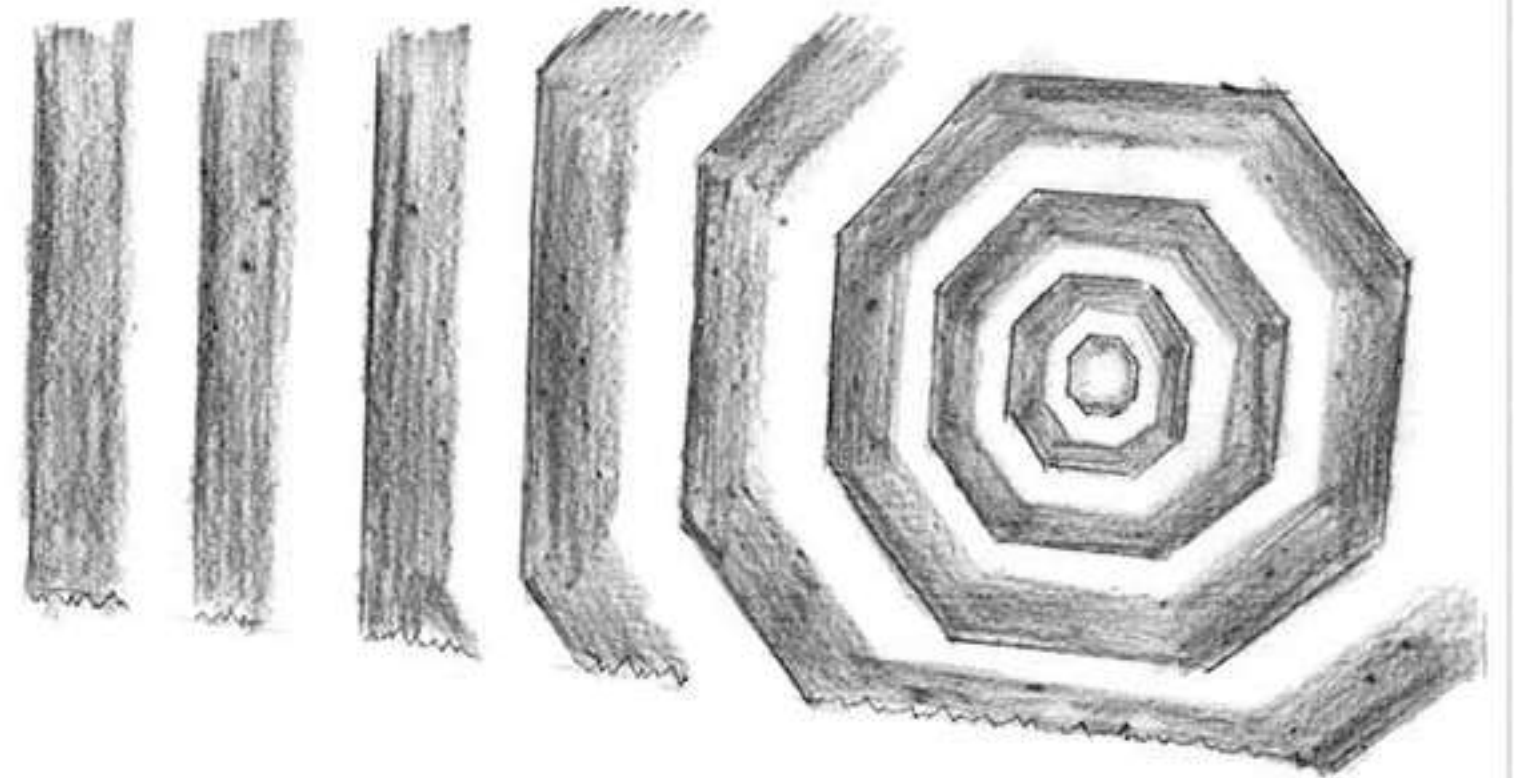

β⑧ END

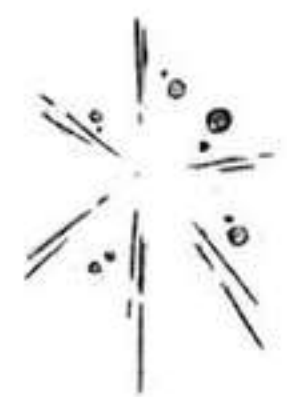

↓⑤



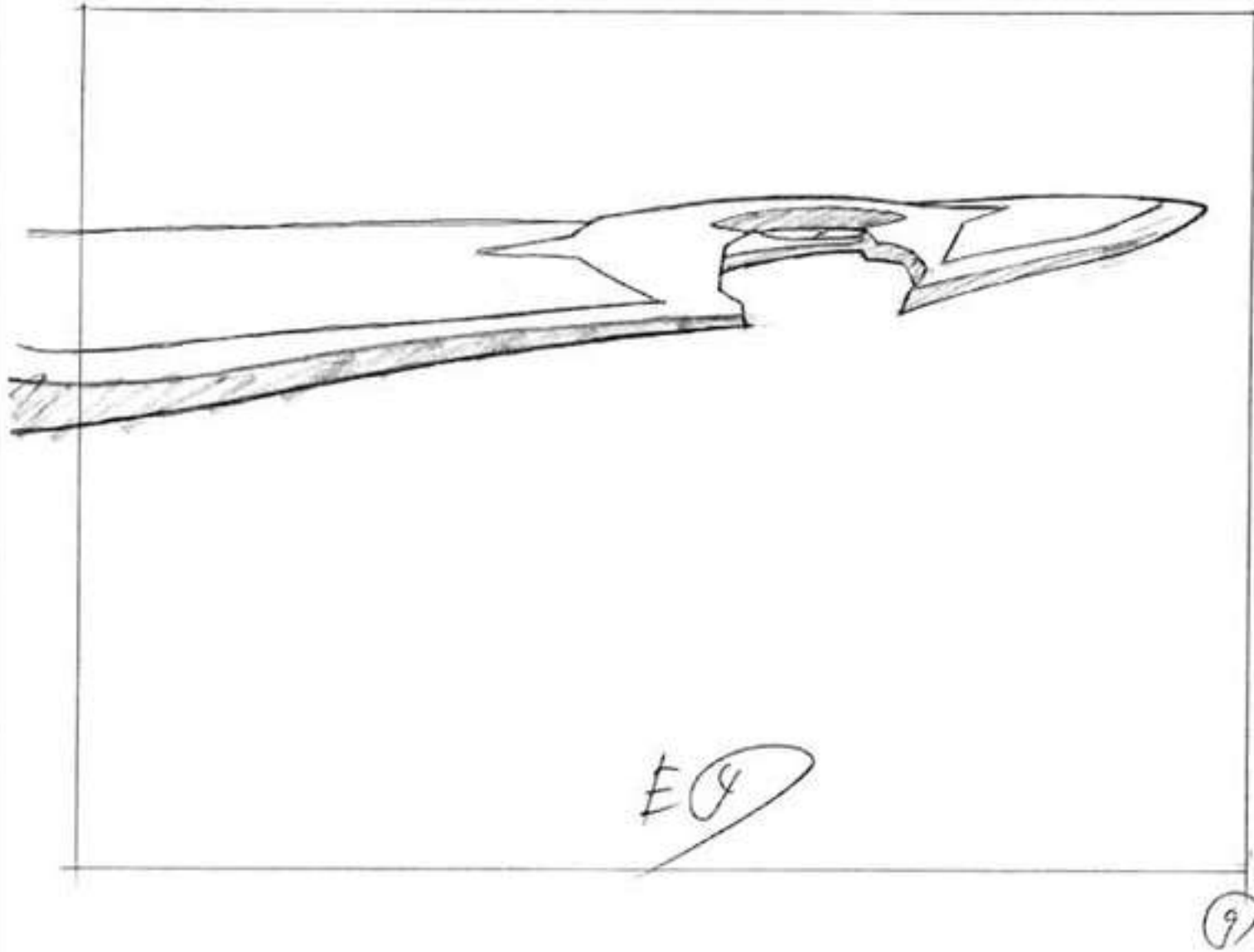

E(4)

(9)

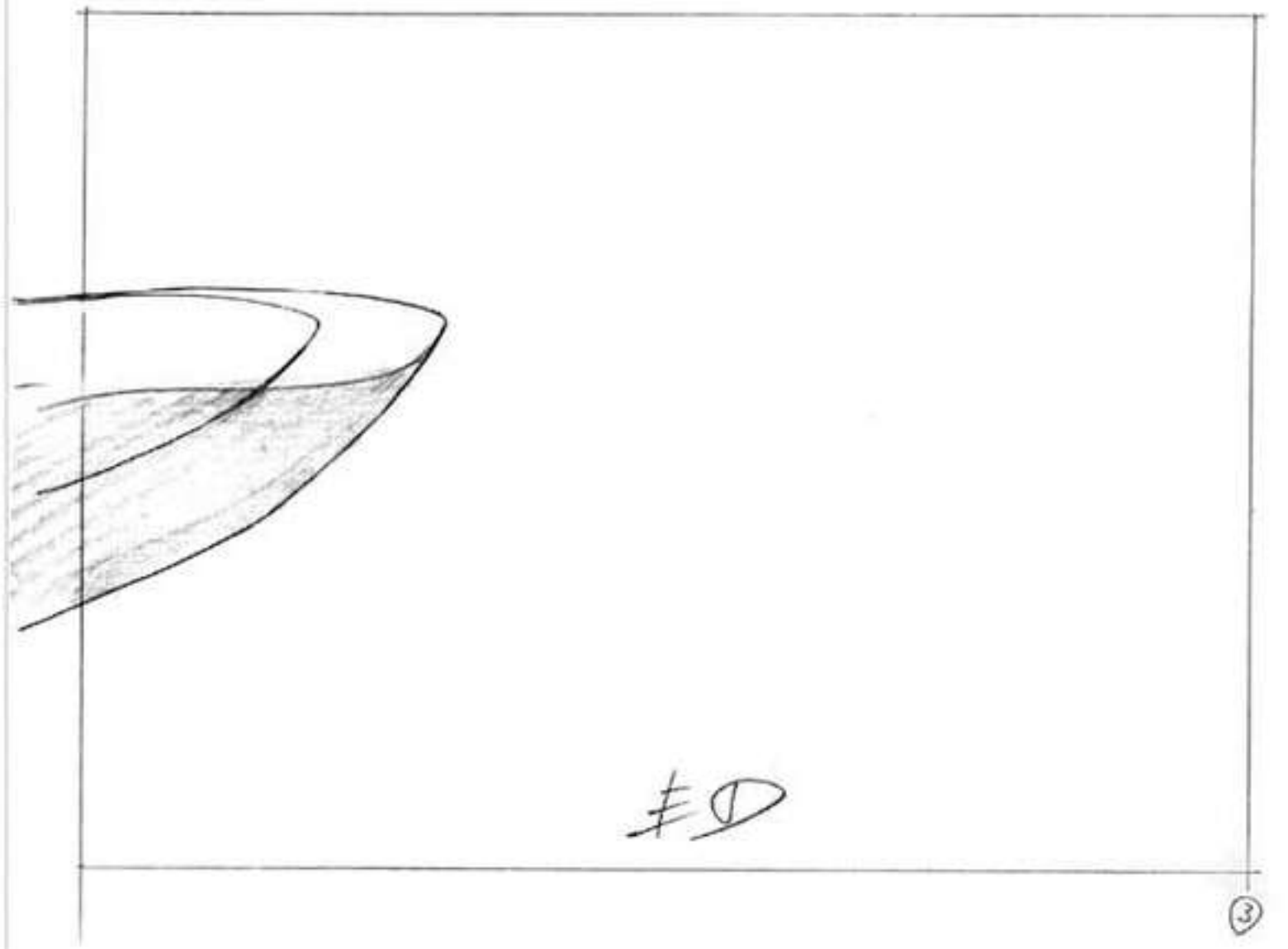

E(1)

(3)

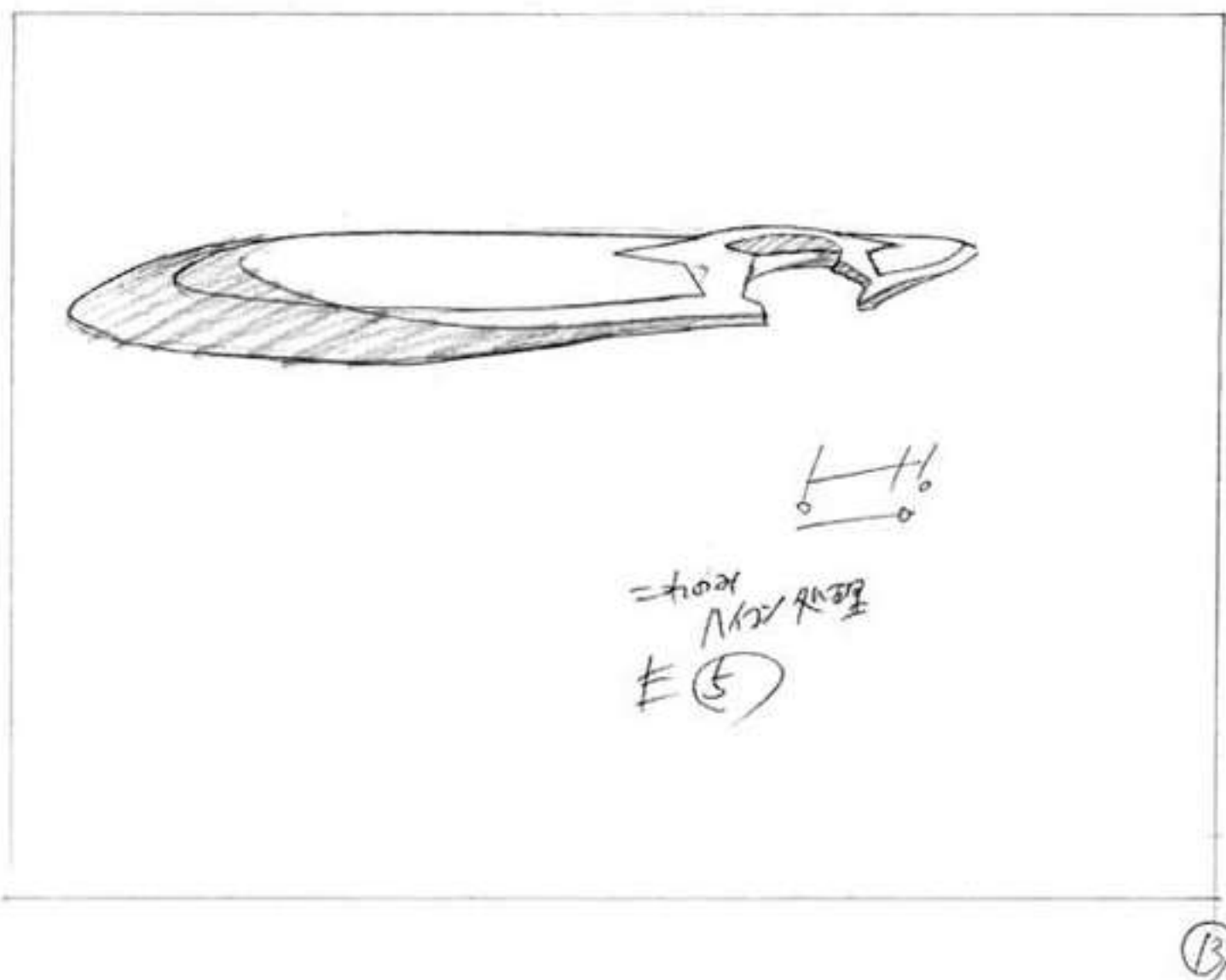

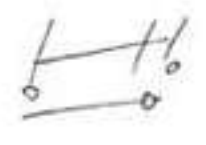
  
 = 100%  
 100% 100%  
 E(5)

(13)

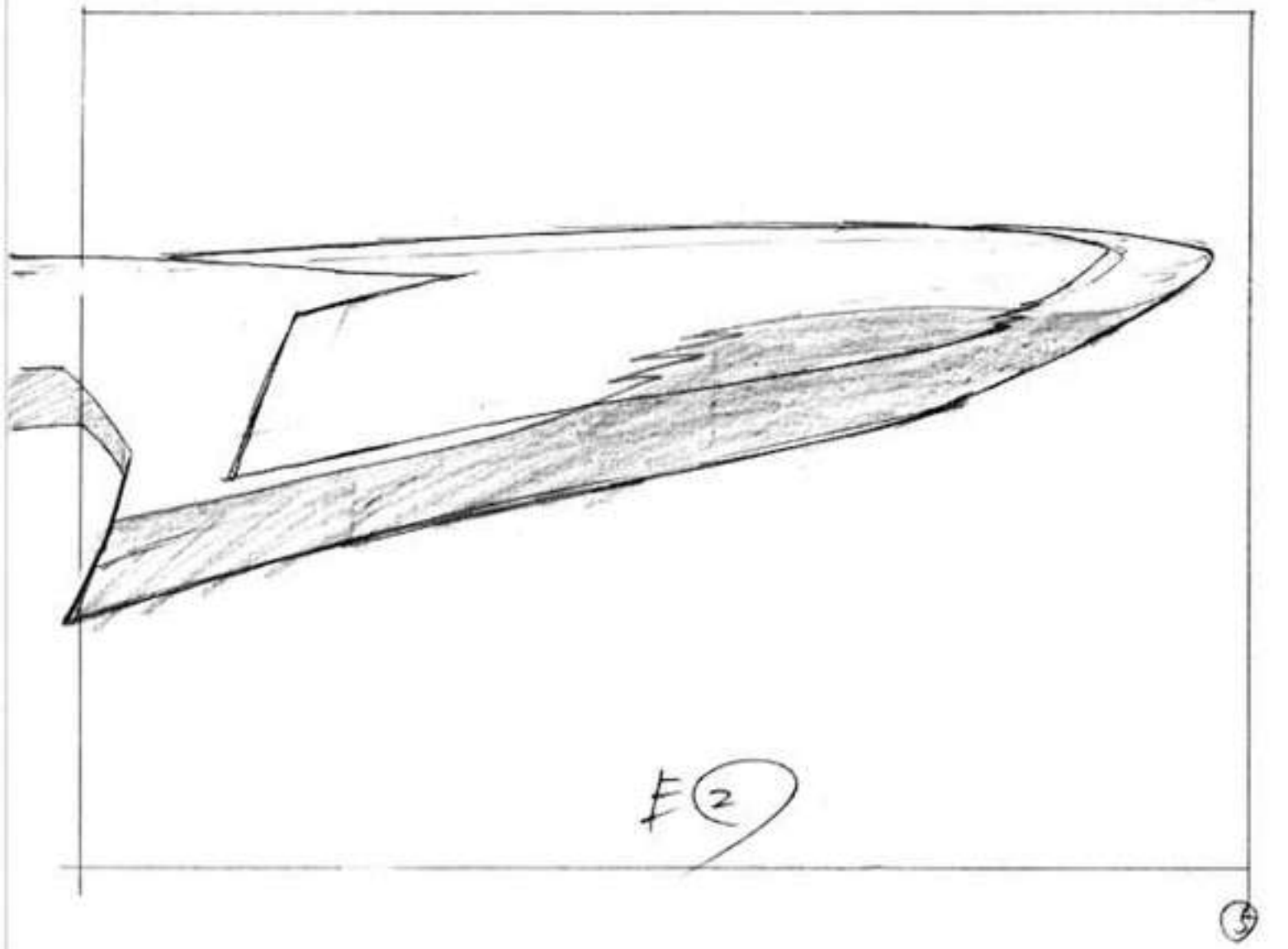

E(2)

(5)

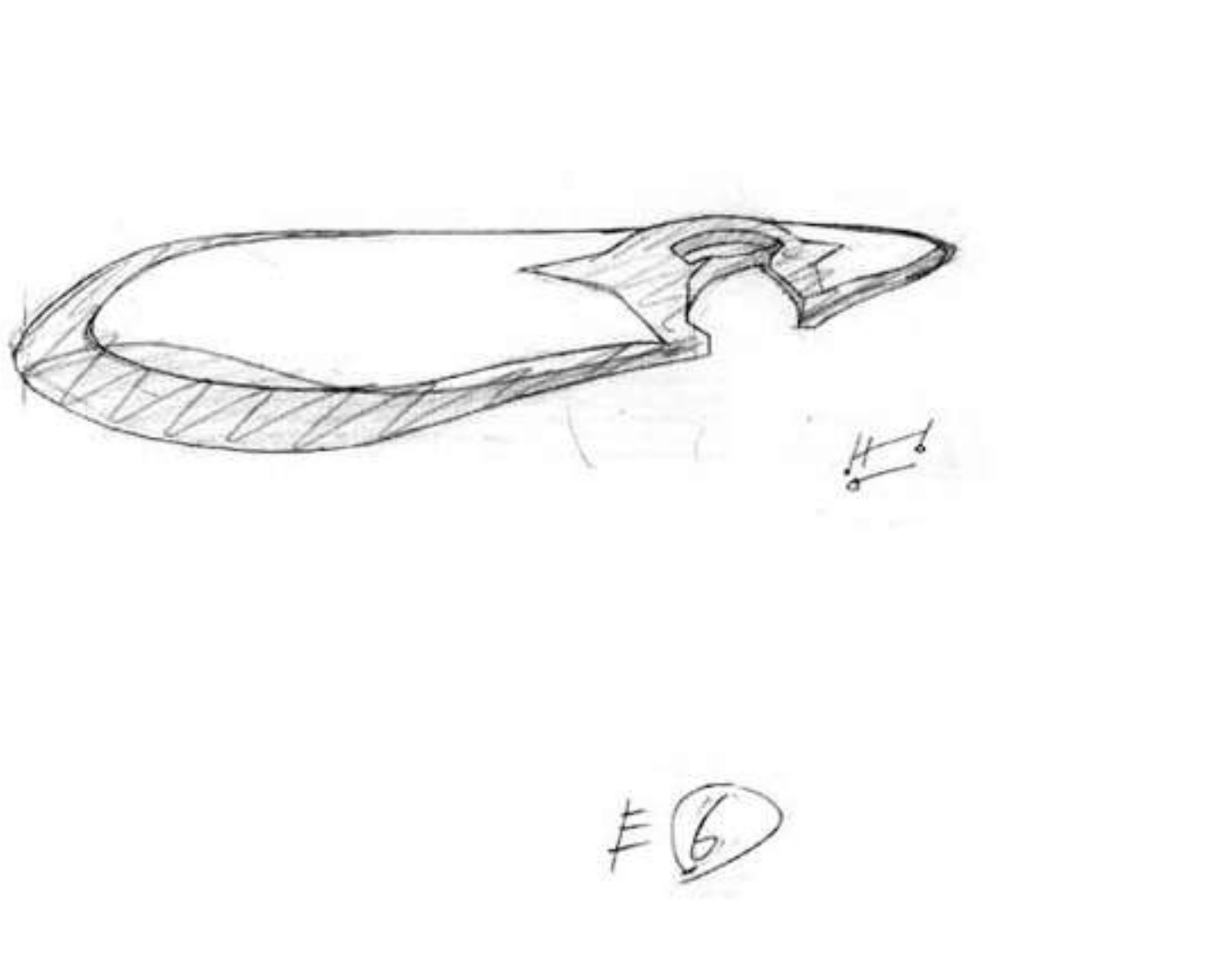

E(6)



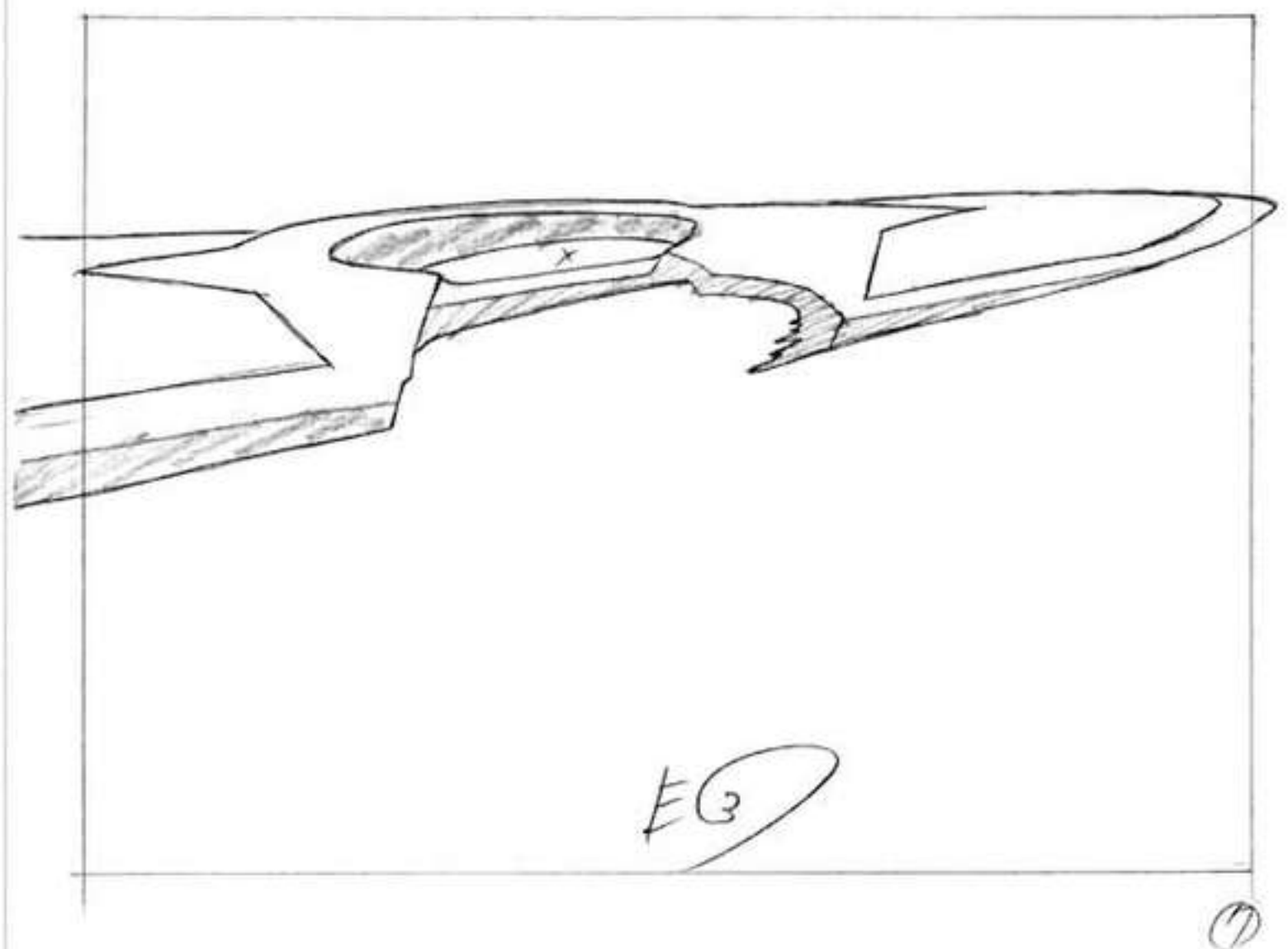

E(3)

(7)



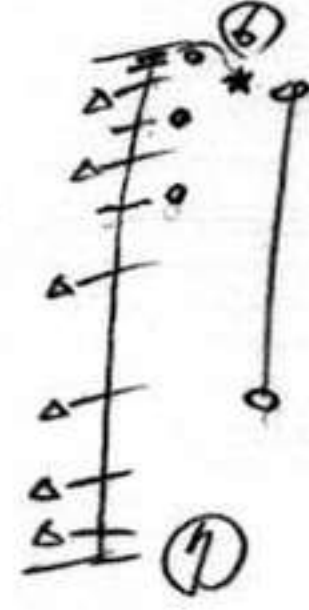
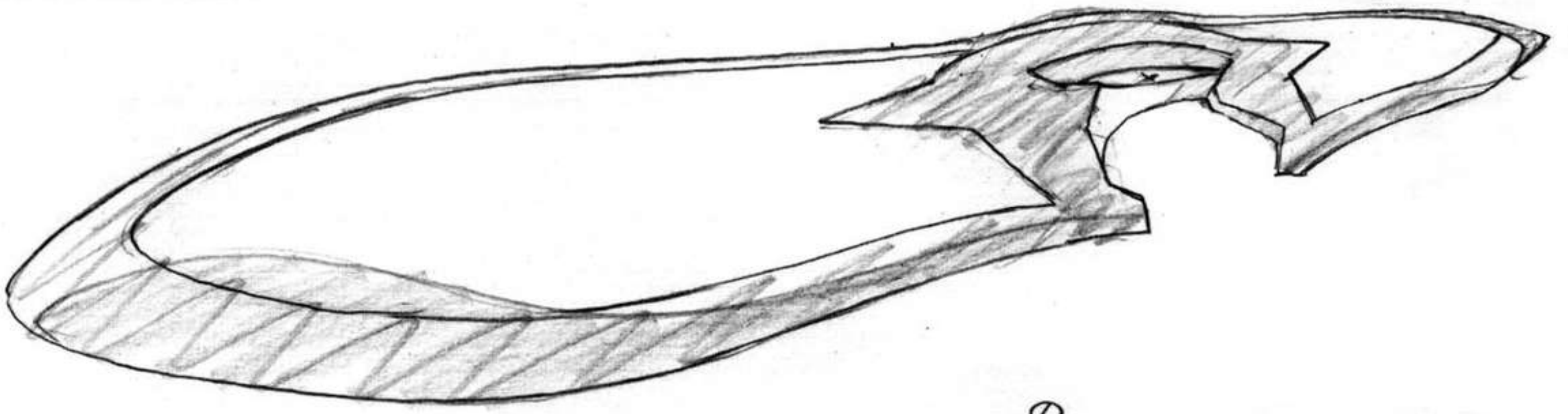

E (10)

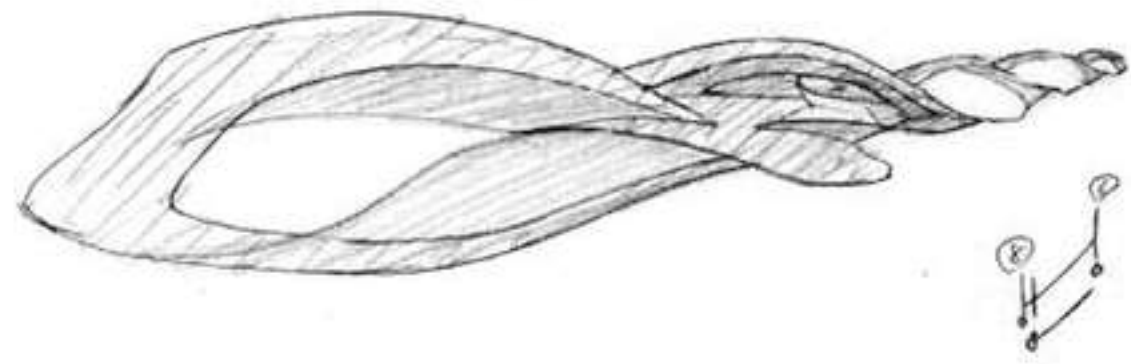
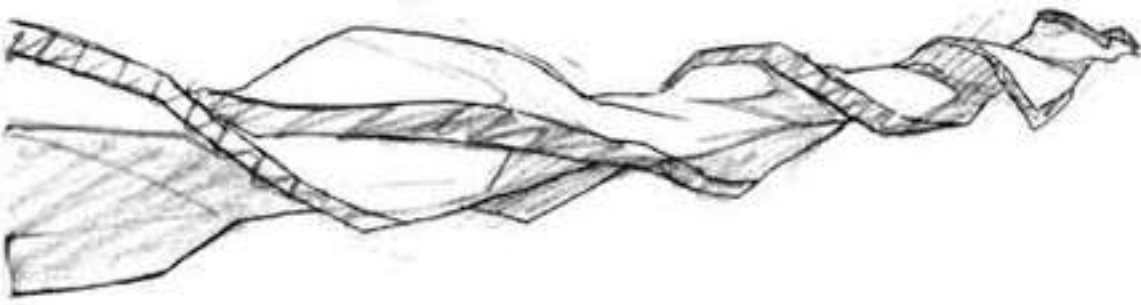

E (8)

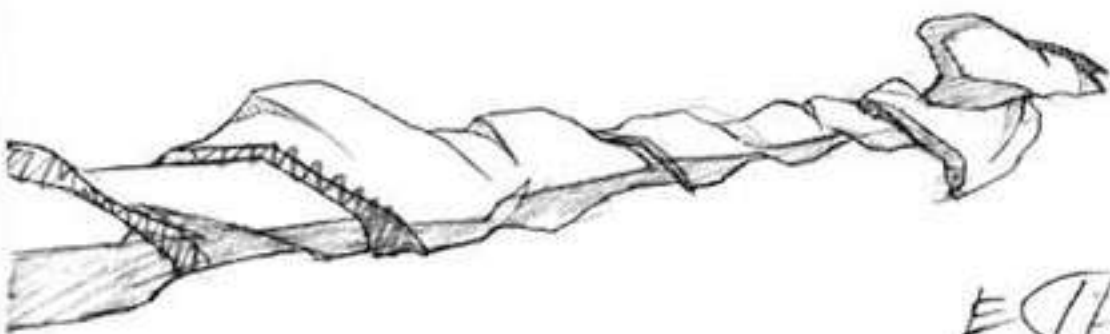

E (11)

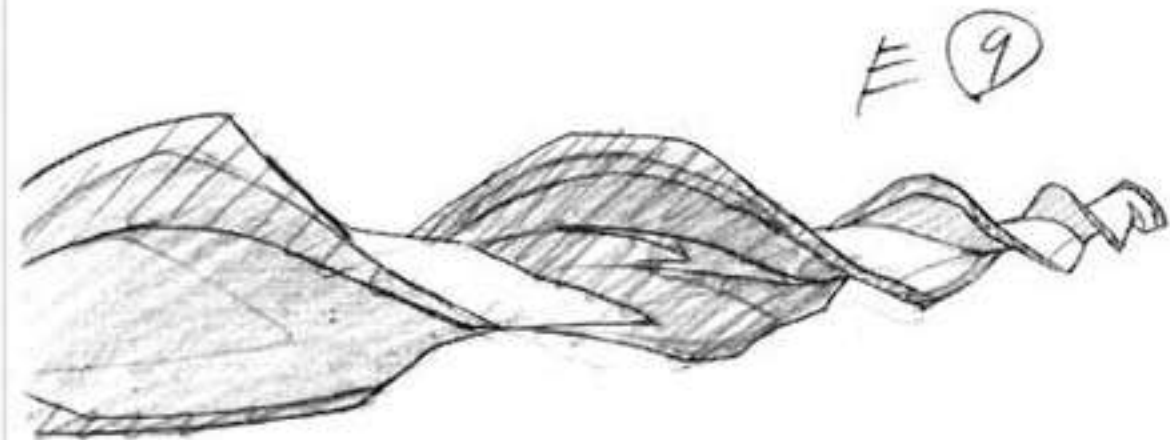

E (9)



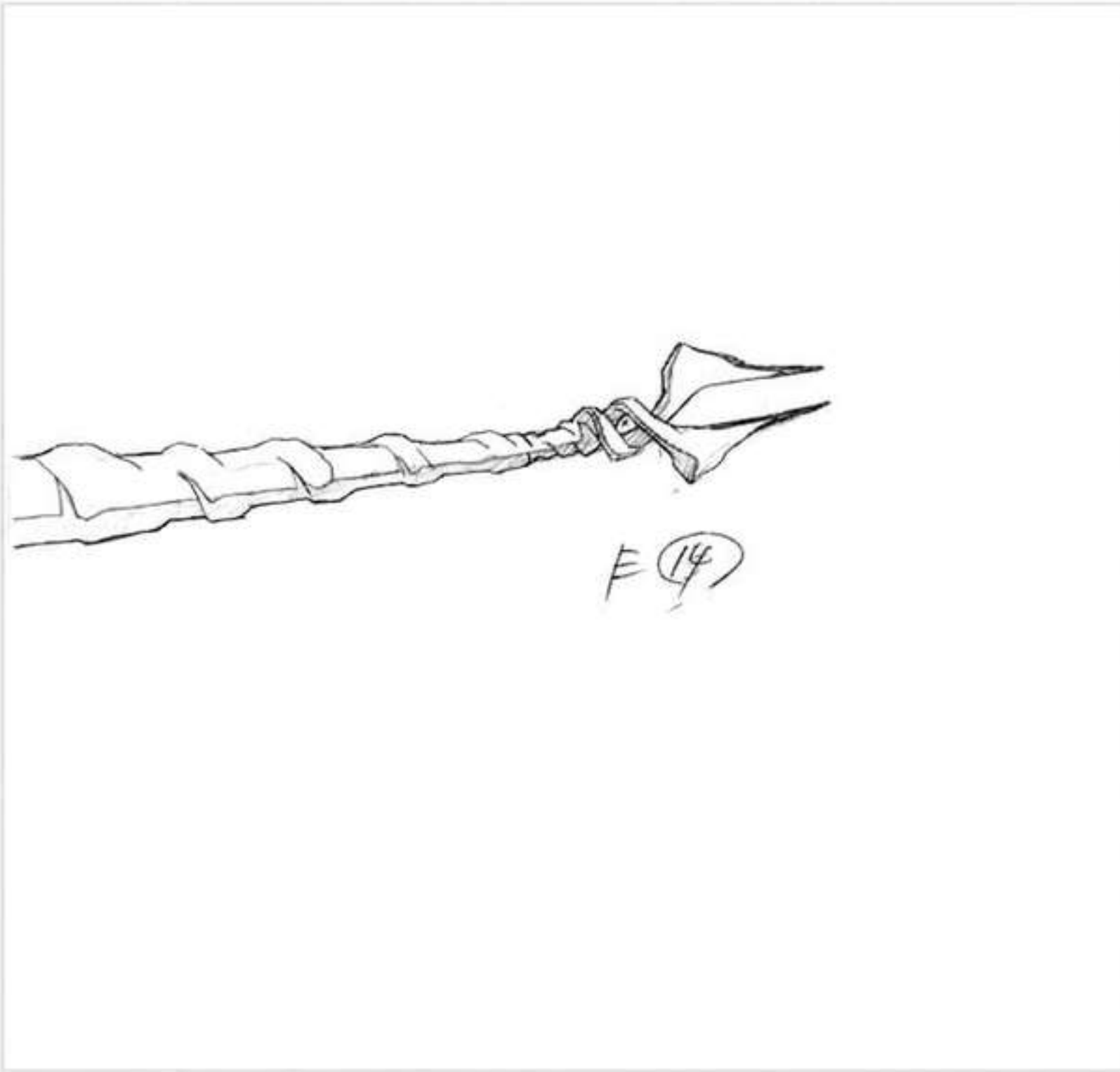

F (14)

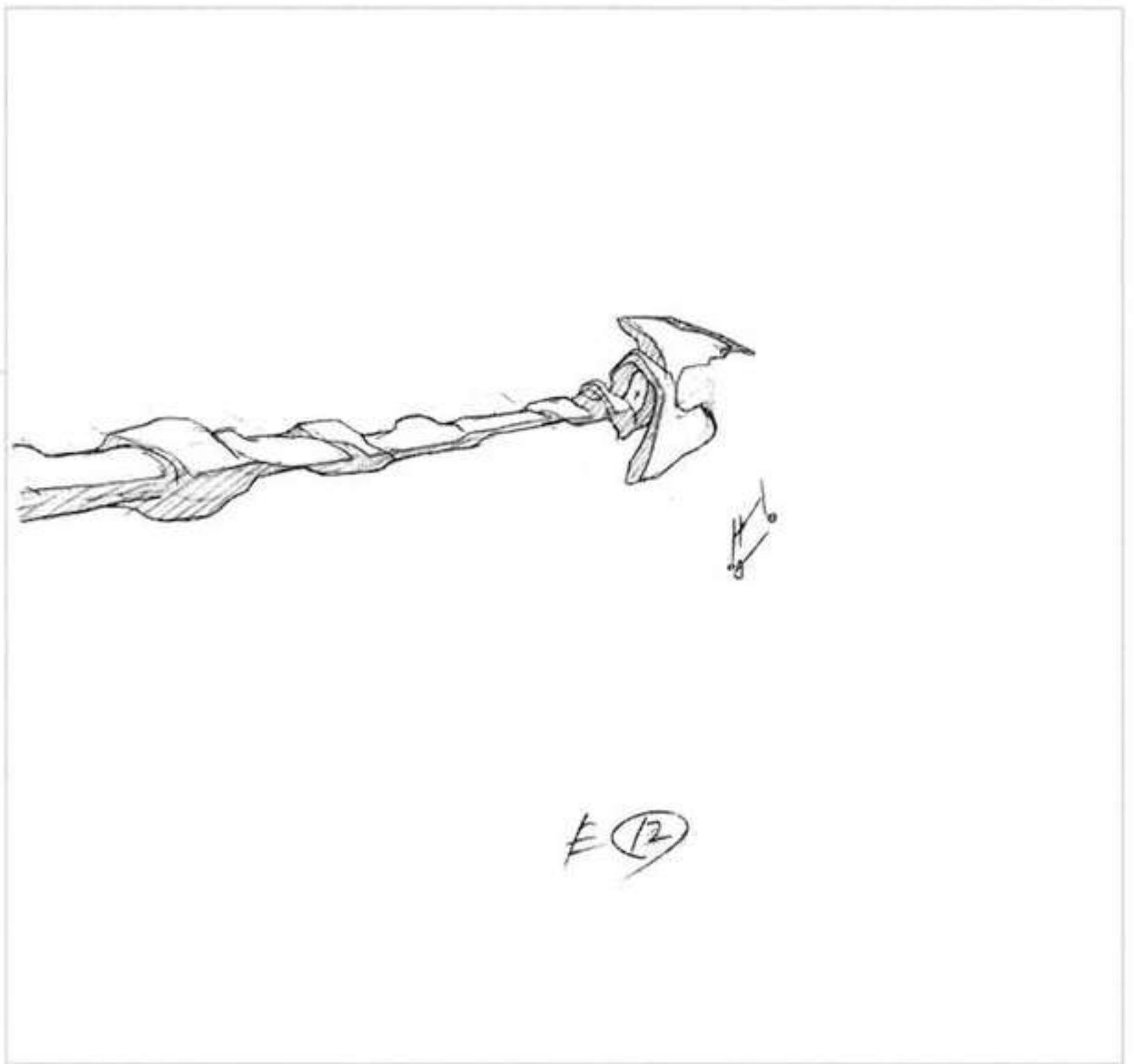

F (12)

#25-C528

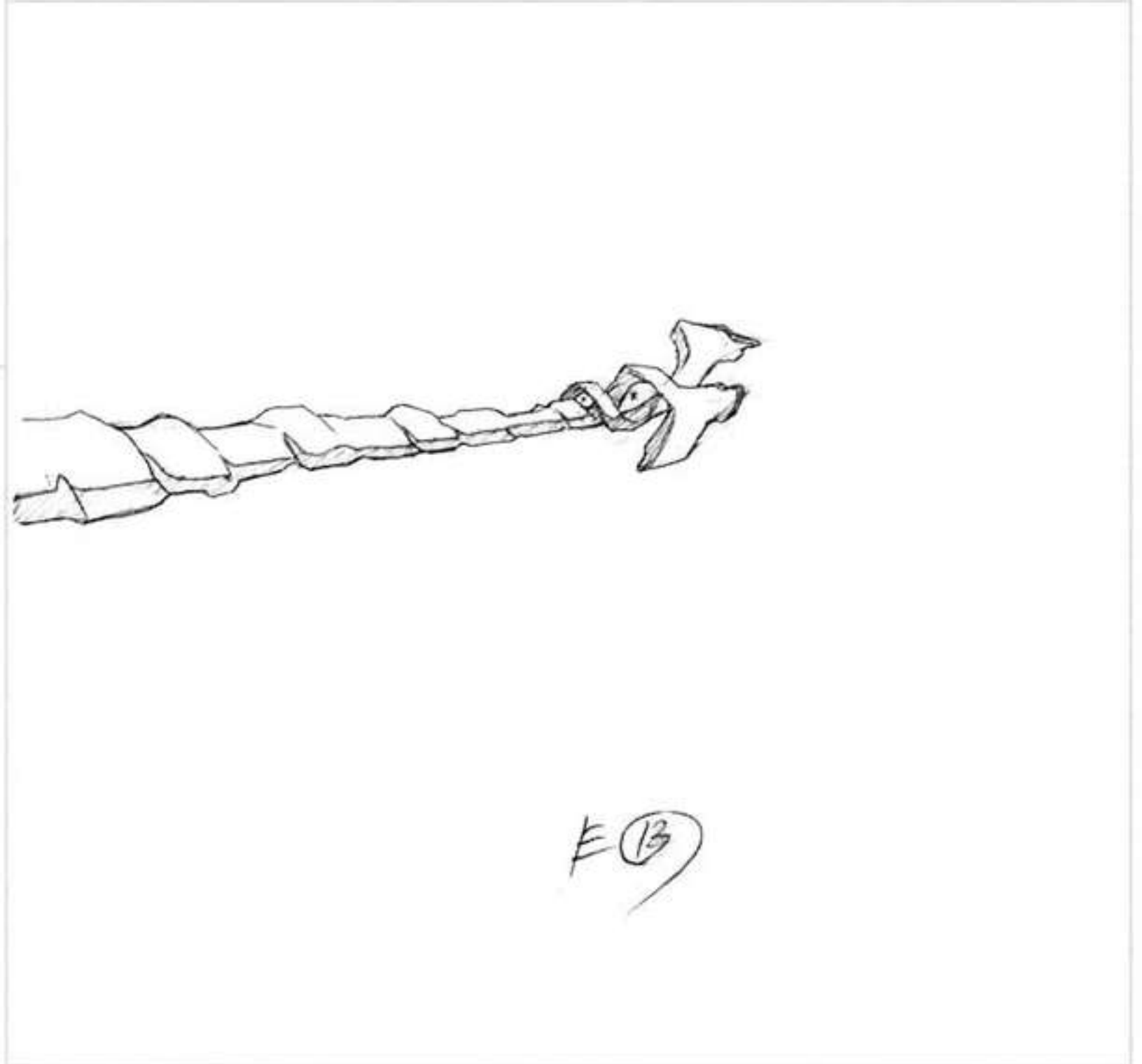

F (13)

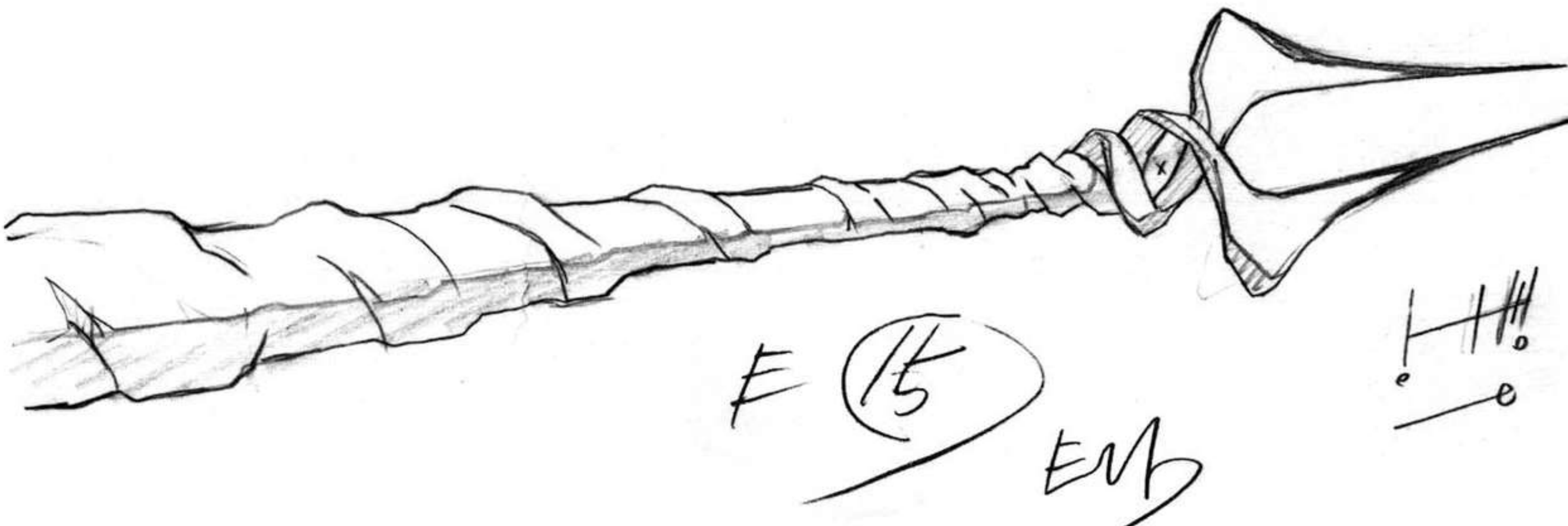

F (15)

EMB

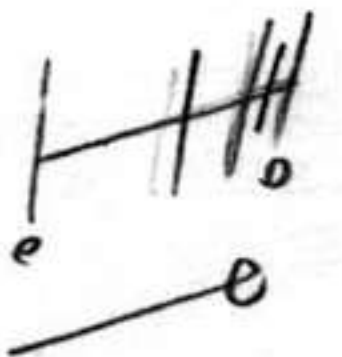



(B1)

1/10 凄味



#25-C531

修正原画



顔の7/49  
不要!



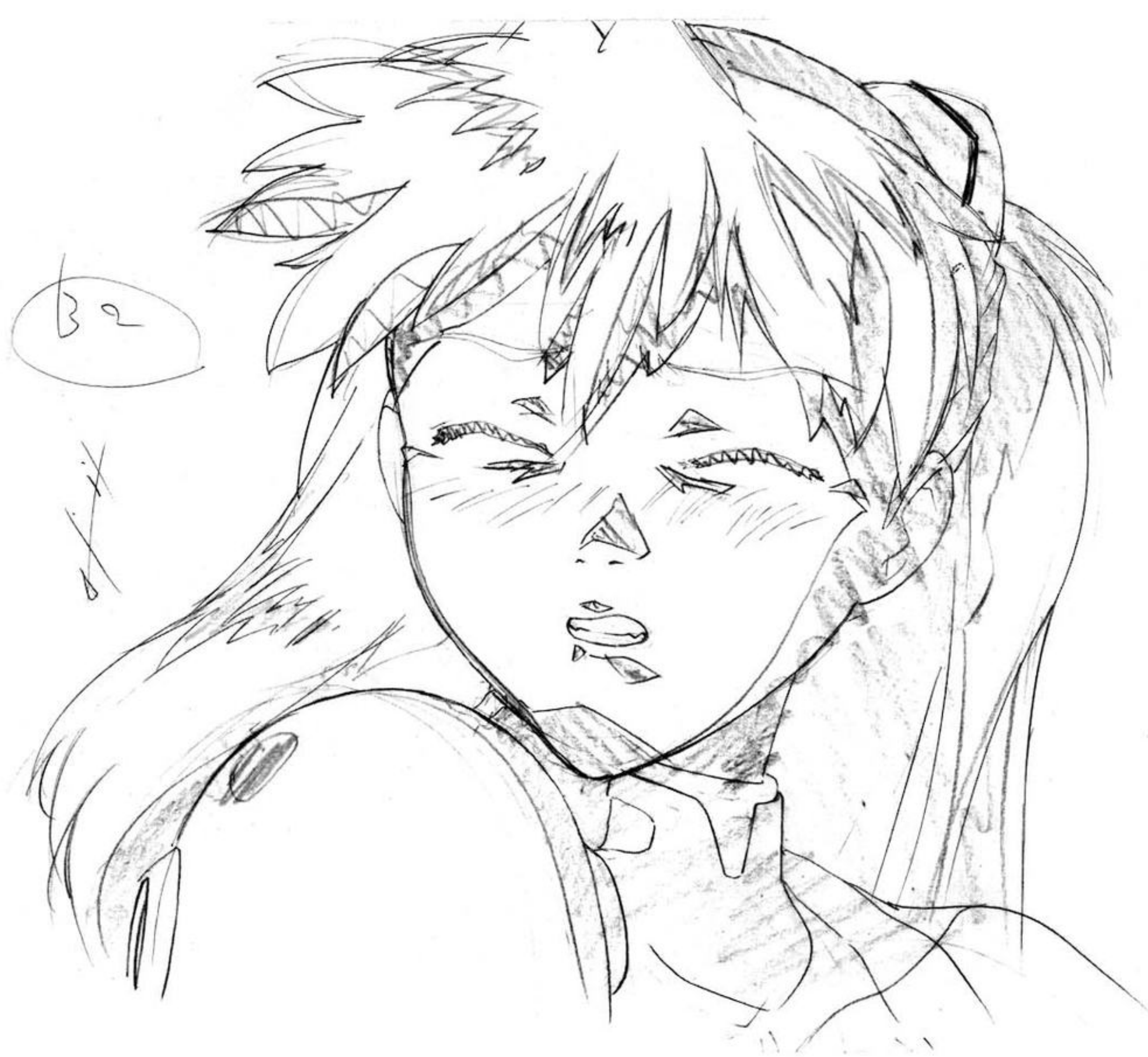

修正原画





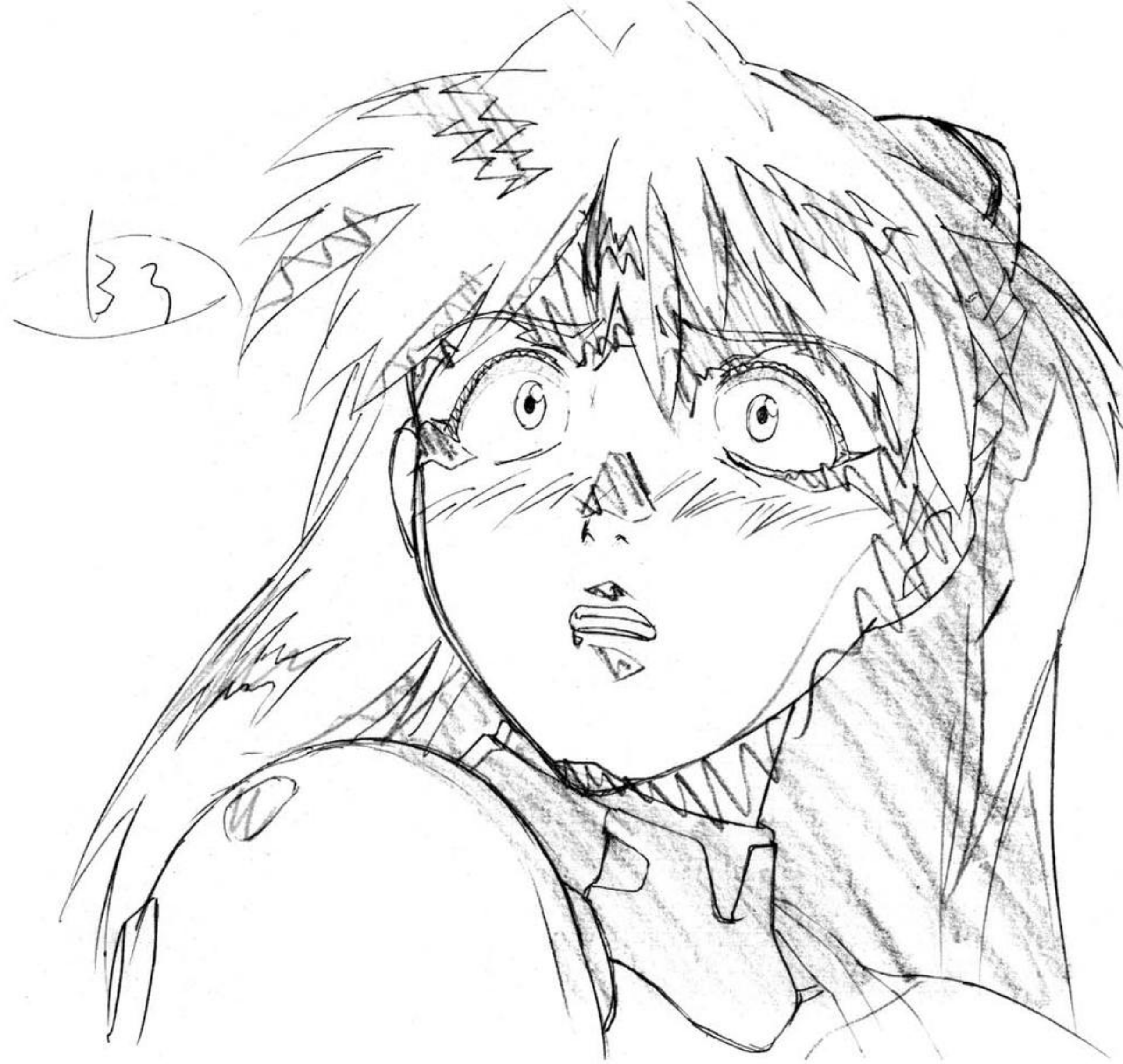

修正原画

33  
修









手  
田  
E.P.

#25-C532





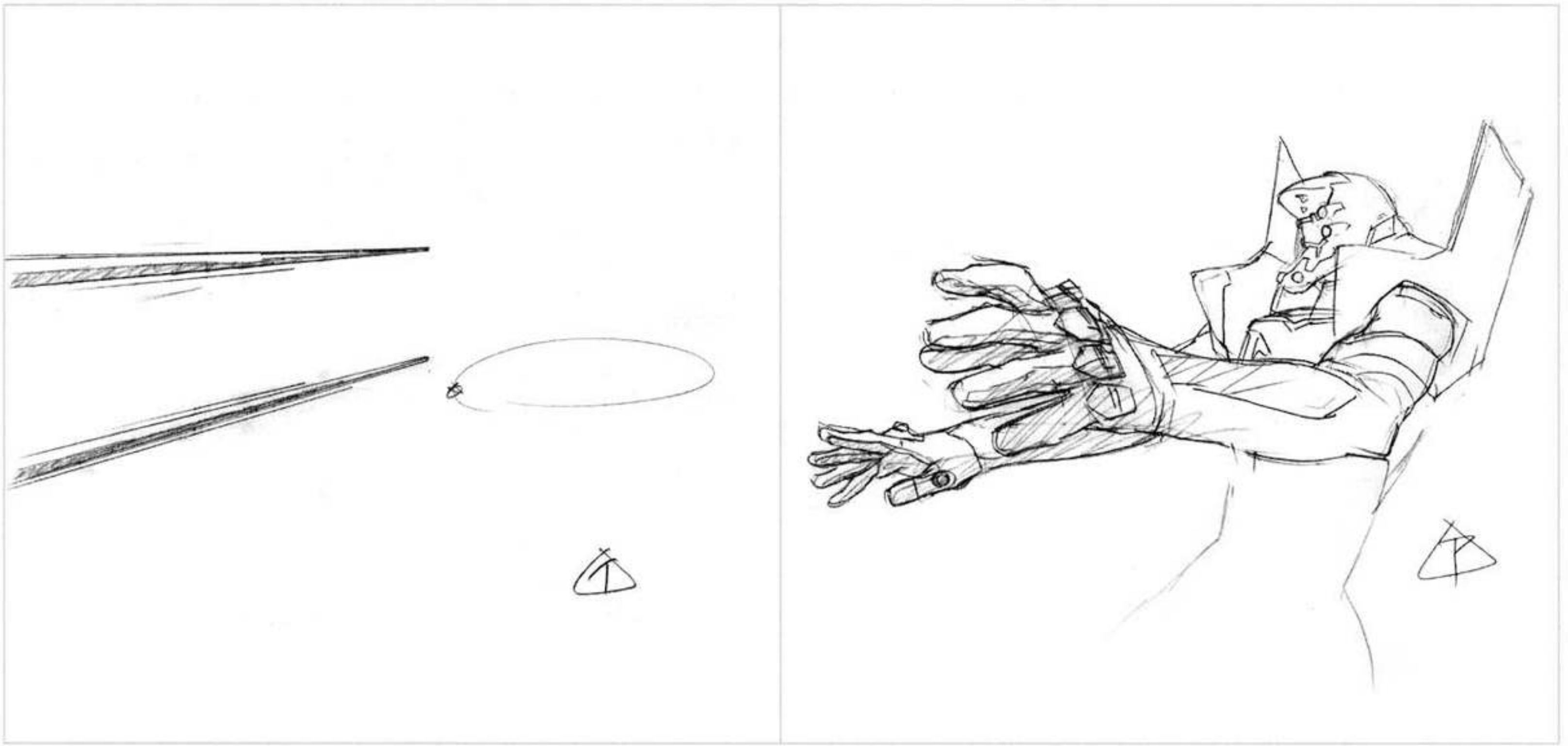



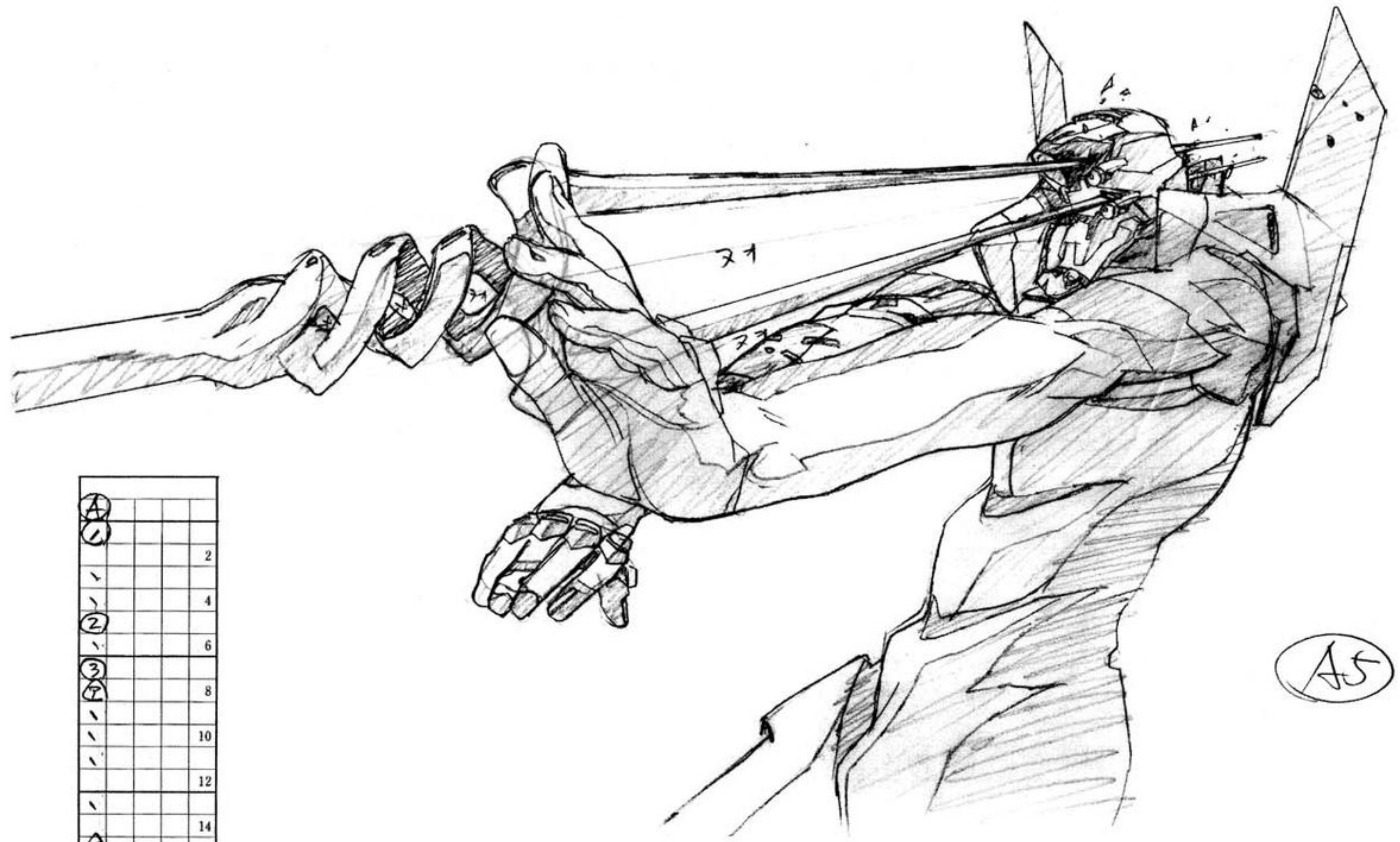

①		
②		2
✓		4
③		6
④		8
✓		10
✓		12
✓		14
⑤		16
⑥		18
✓		20
✓		22
✓		24
✓		26
⑦		28

#25-C532  
タイムシート

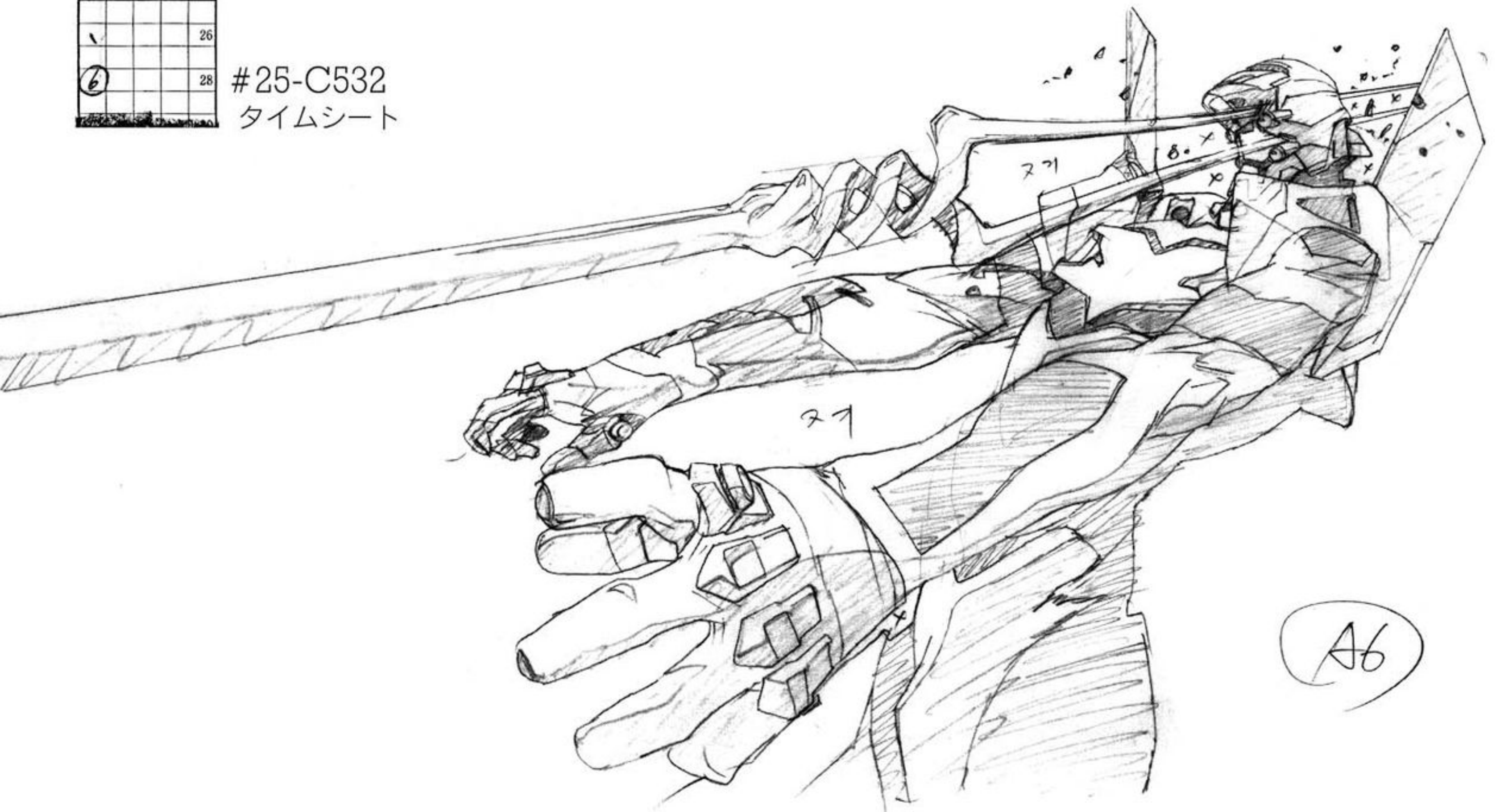



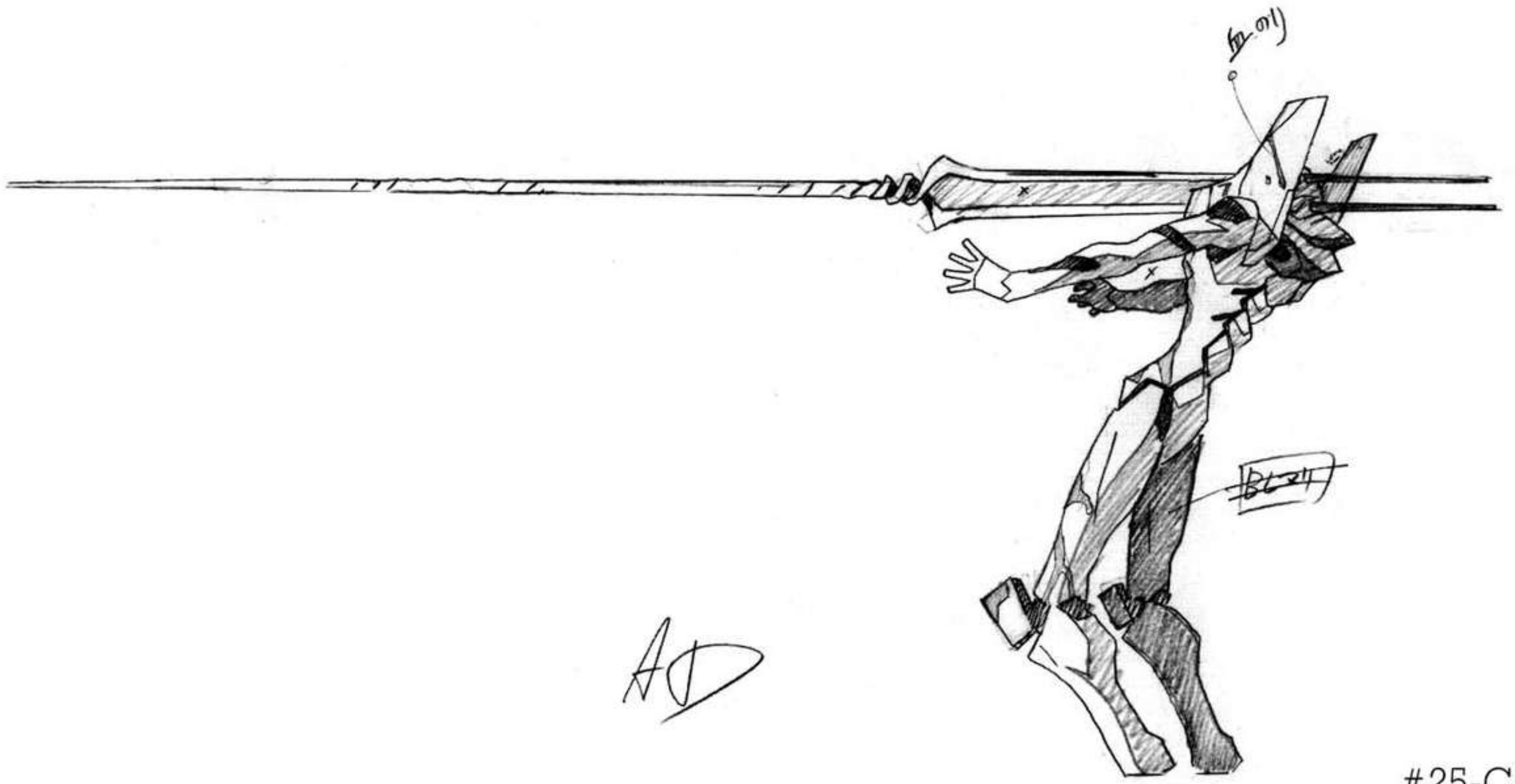

#25-C533

修正原画

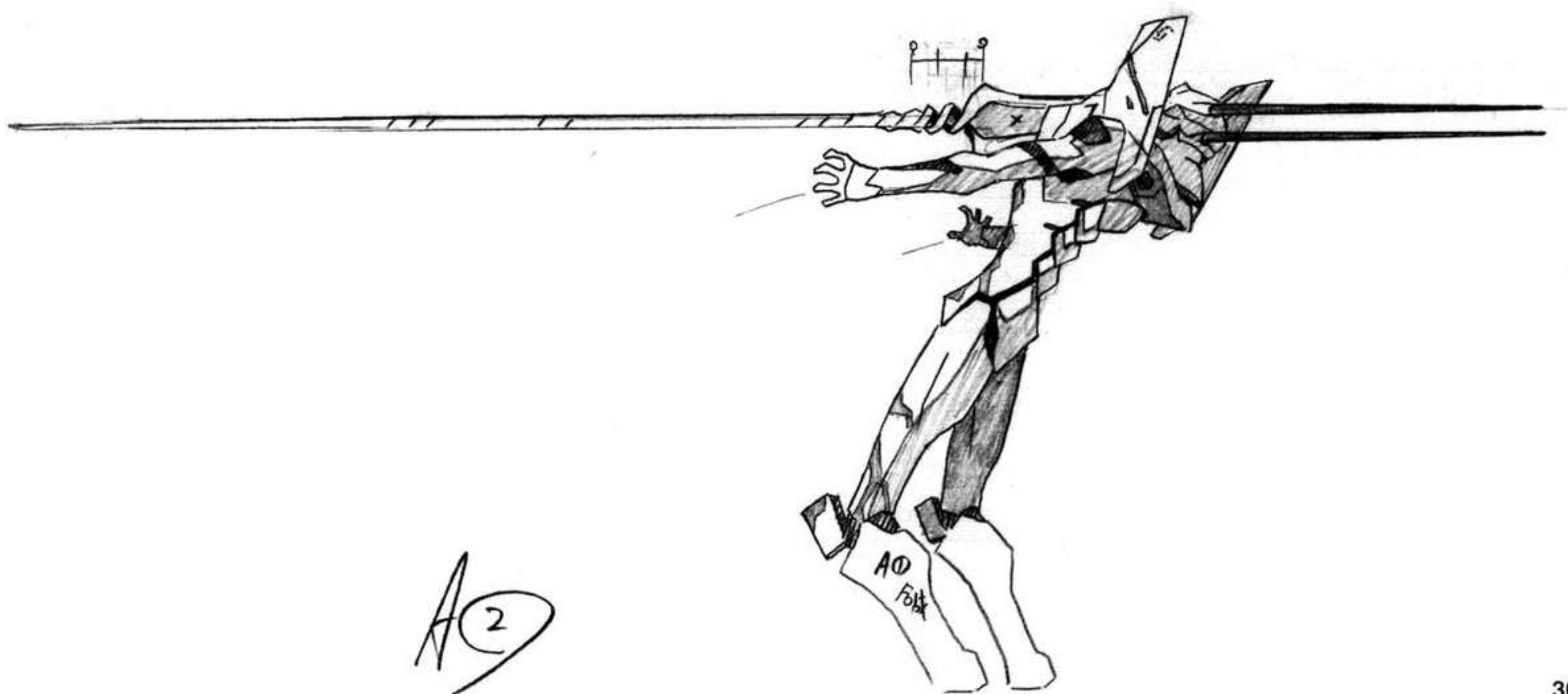
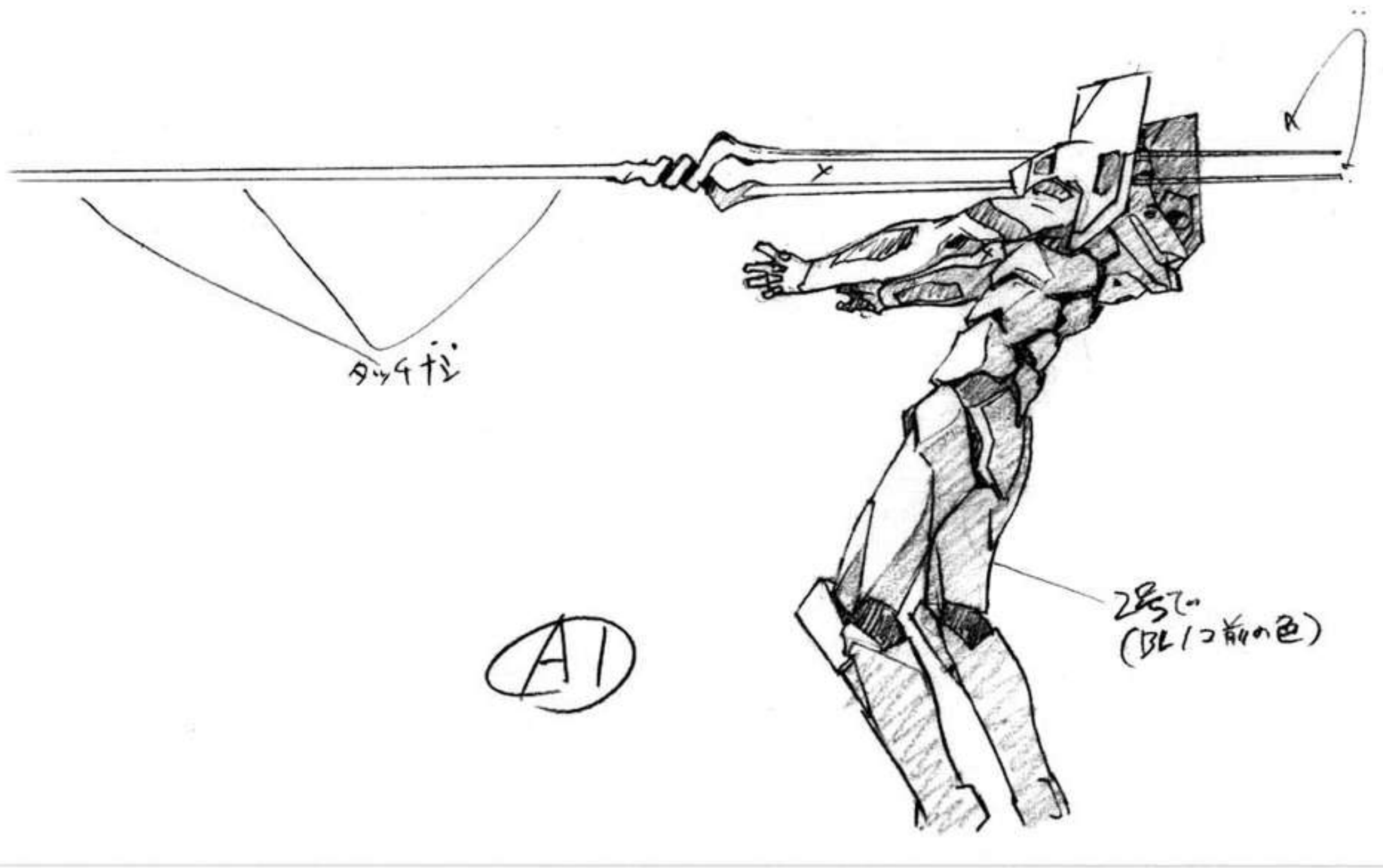



修正原画

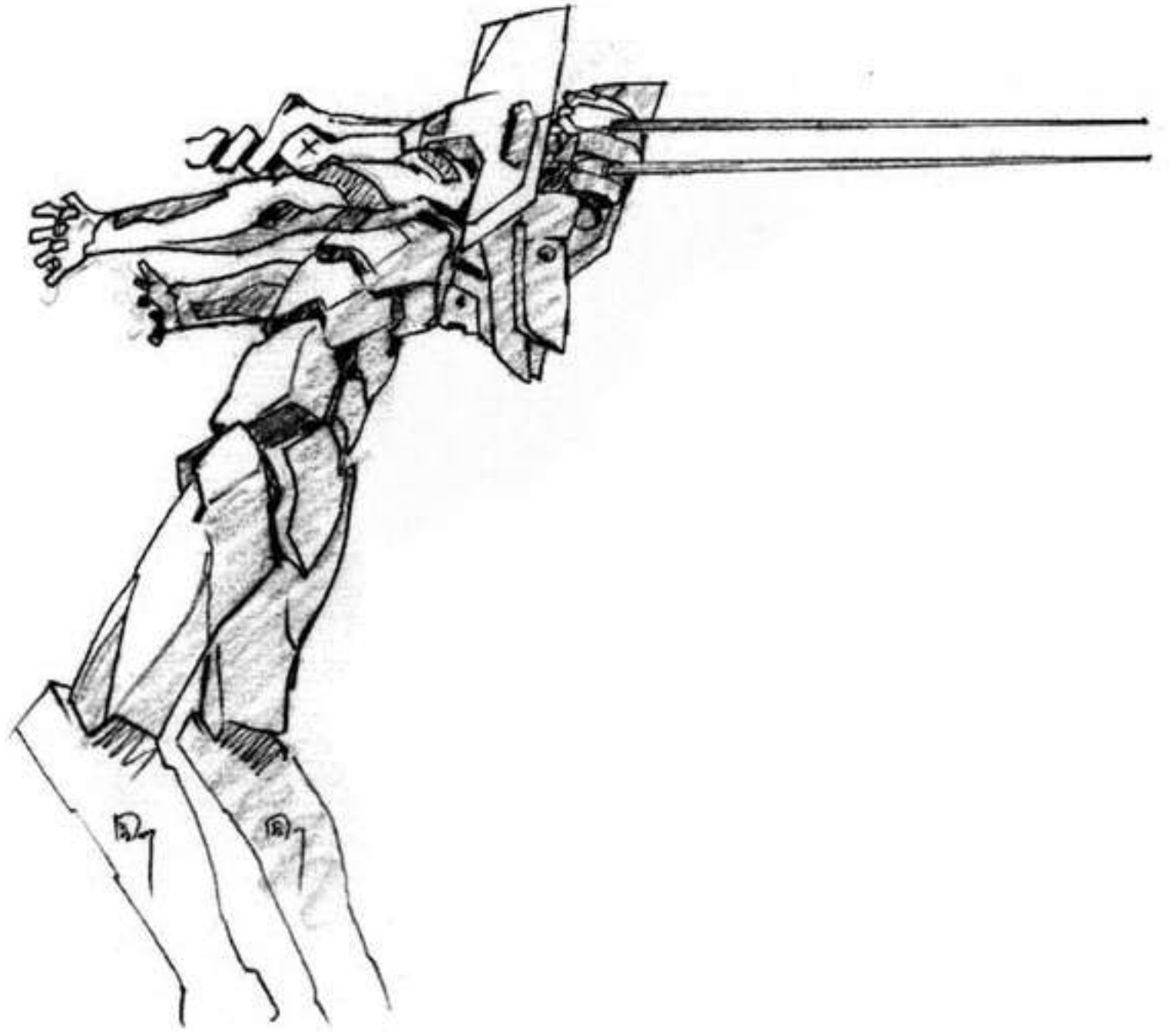

A2

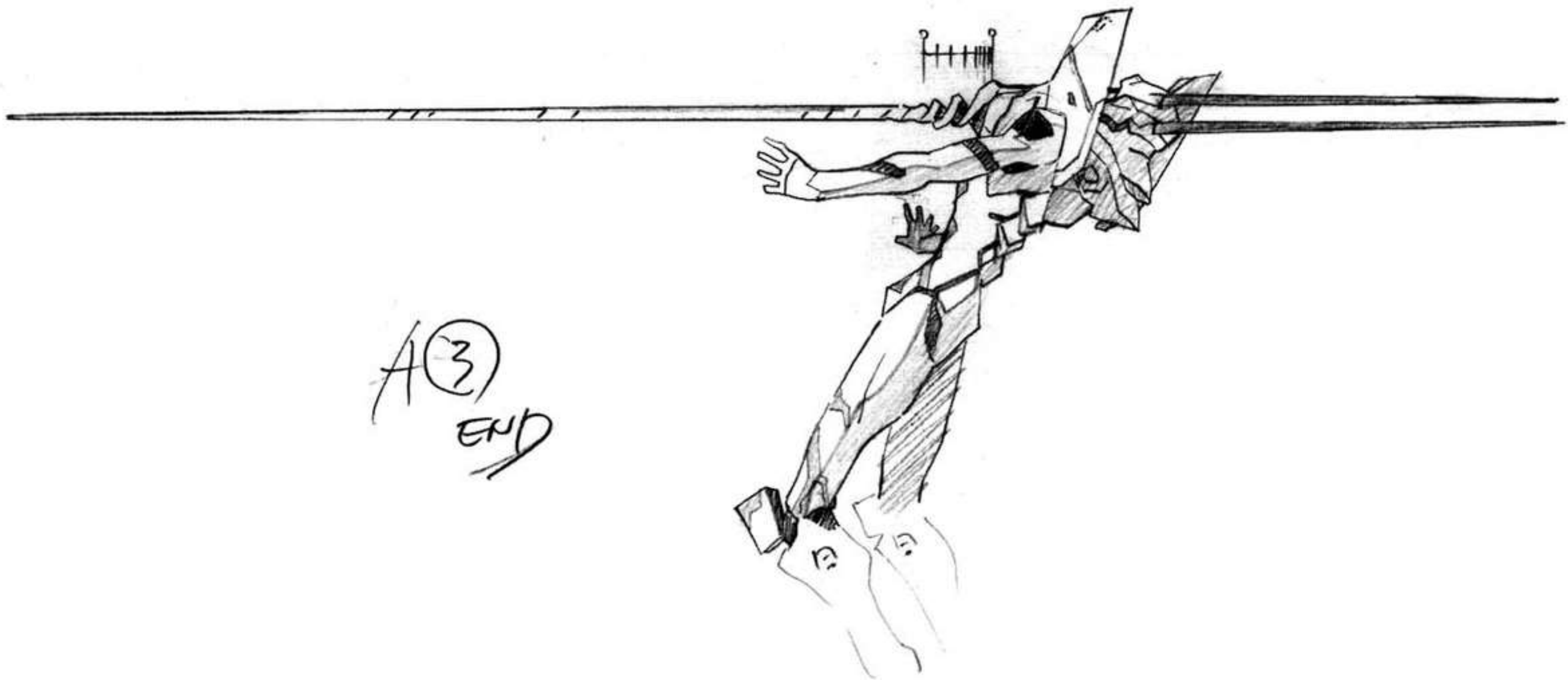

A(3) END

修正原画

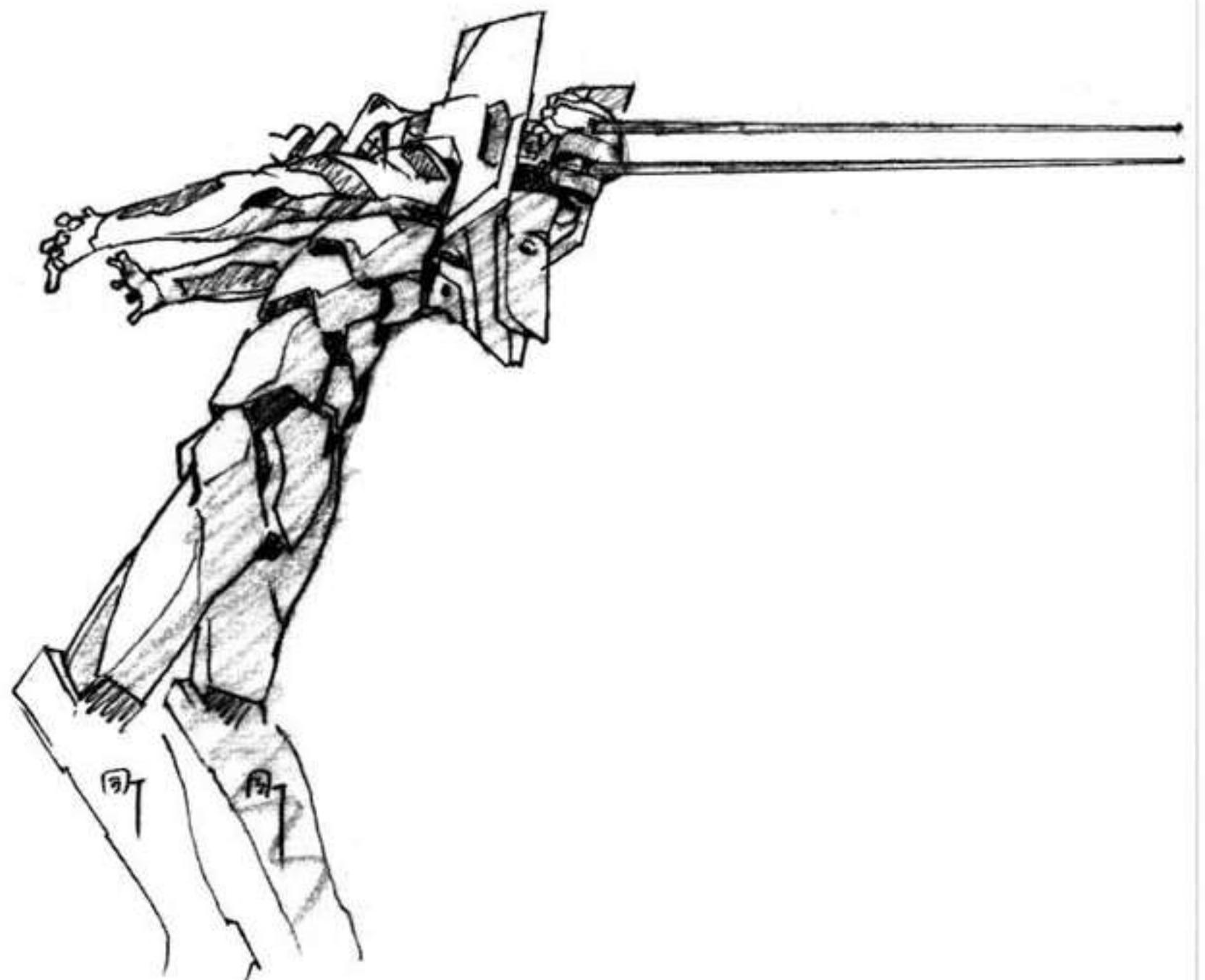

A3







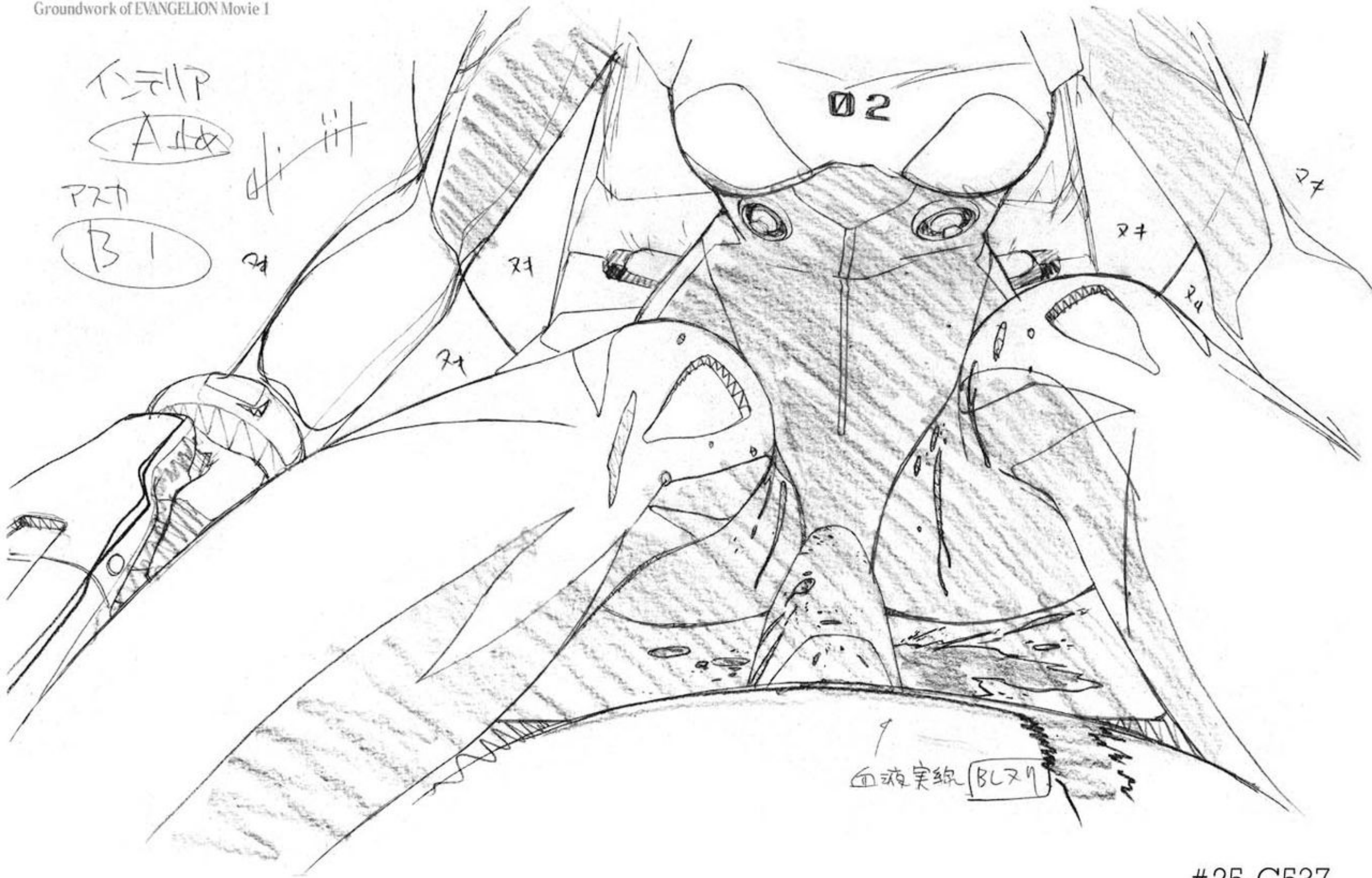

#25-C537

修正原画

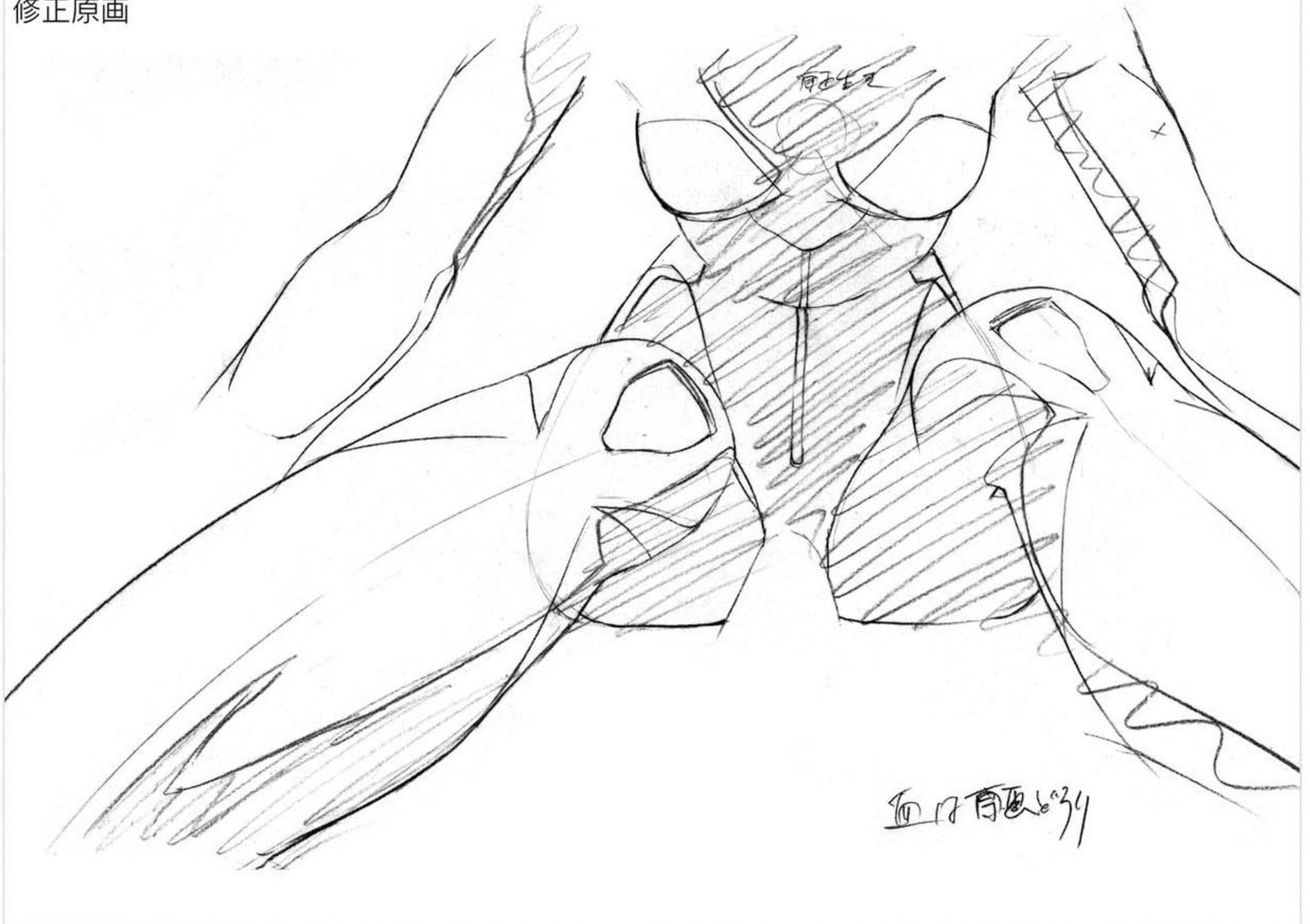





修正原画



修正原画







1250 A10

1250 A10

1250 B1



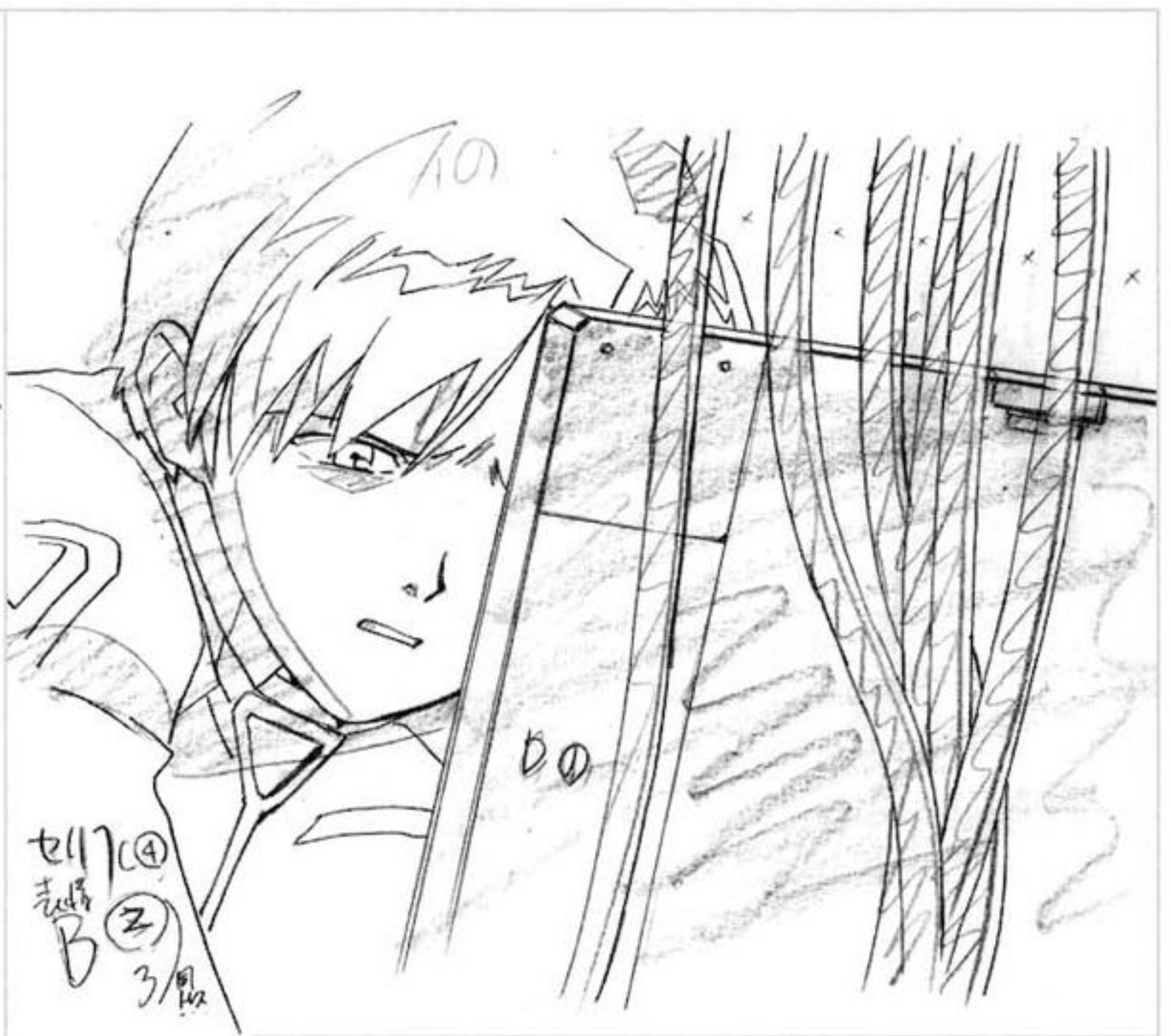

#25-C540,543



修正原画

267  
 C567

A 2  
 B 3  
 B-3  
 4



修正原画

#25-C544

A3

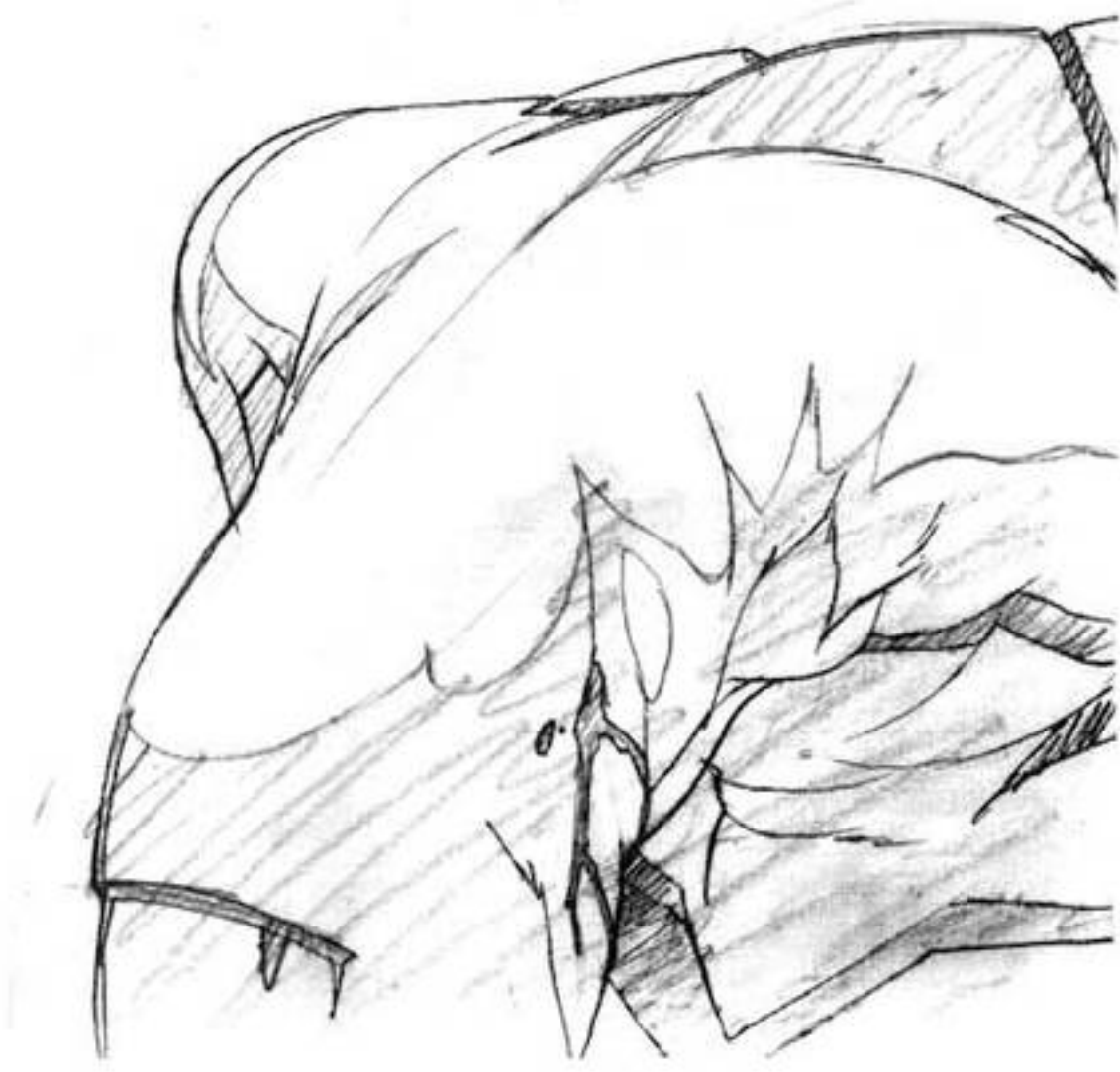

A0

修正原画  
A2

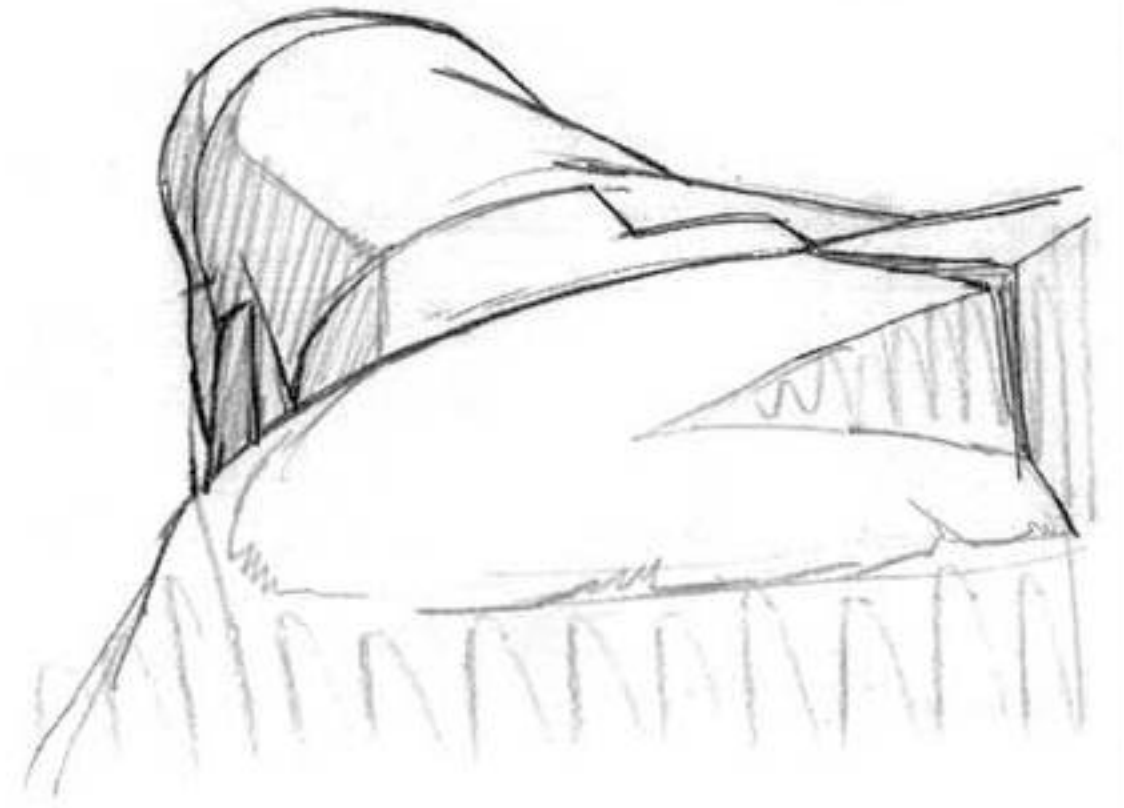

修正原画

A4

中割り  
両端?



修正原画

A4



A3





A5



タイムシート

A	
①	2
②	4
③	6
④	8
⑤	10
⑥	12
⑦	14
⑧	16
⑨	18
⑩	20
⑪	22
⑫	24
⑬	26
⑭	28
⑮	30
⑯	32
⑰	34
⑱	36
⑳	38
㉑	40
㉒	42
㉓	44
㉔	46
㉕	48
㉖	50
㉗	52
㉘	54
㉙	56
㉚	58
㉛	60
㉜	62
㉝	64
㉞	66
㉟	68
㊱	70
㊲	72

修正原画

A5

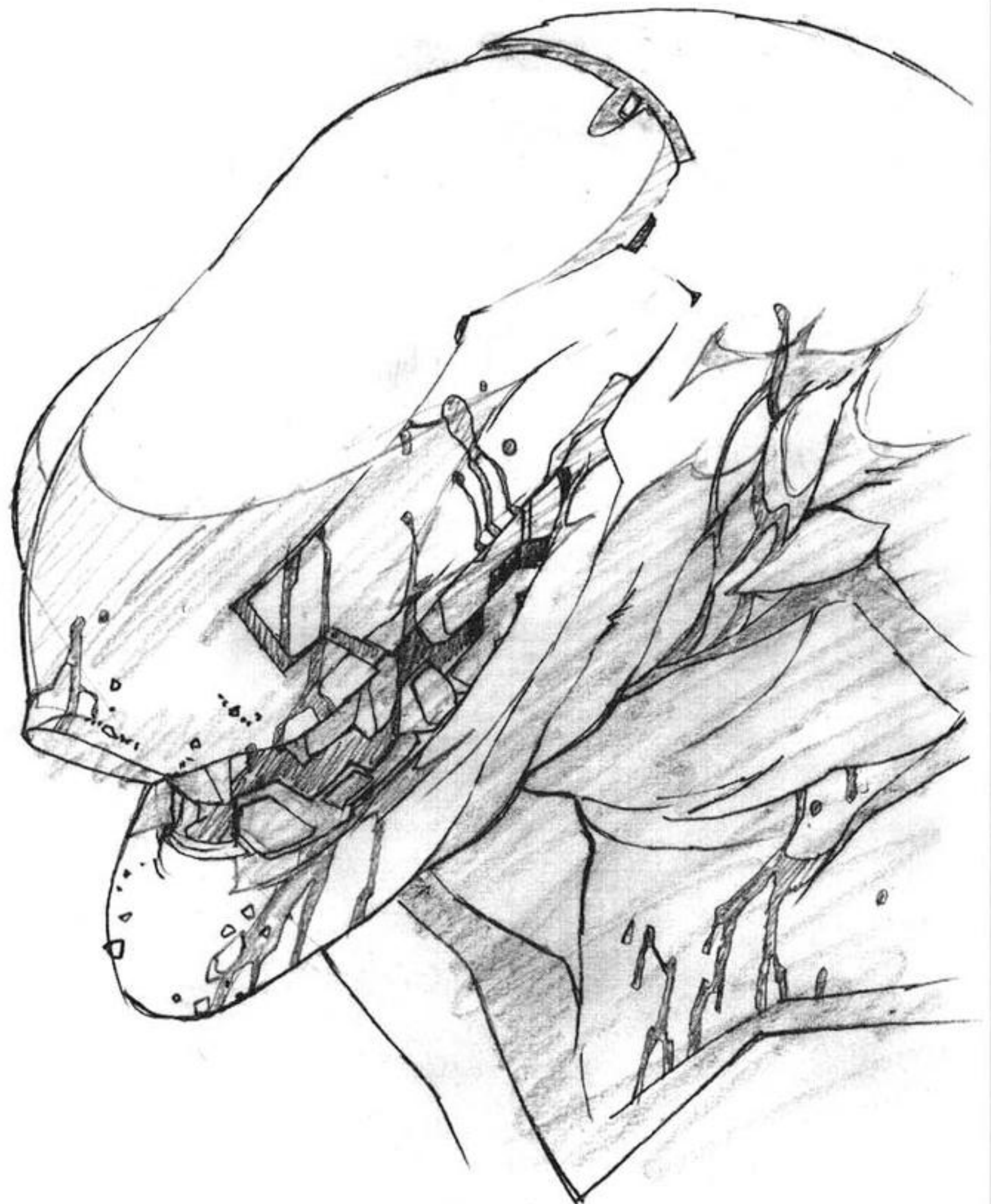

※ 中シテ  
口申下下111

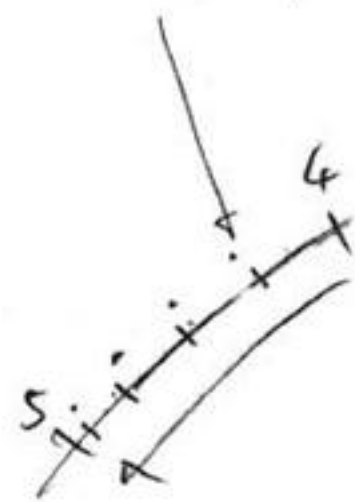



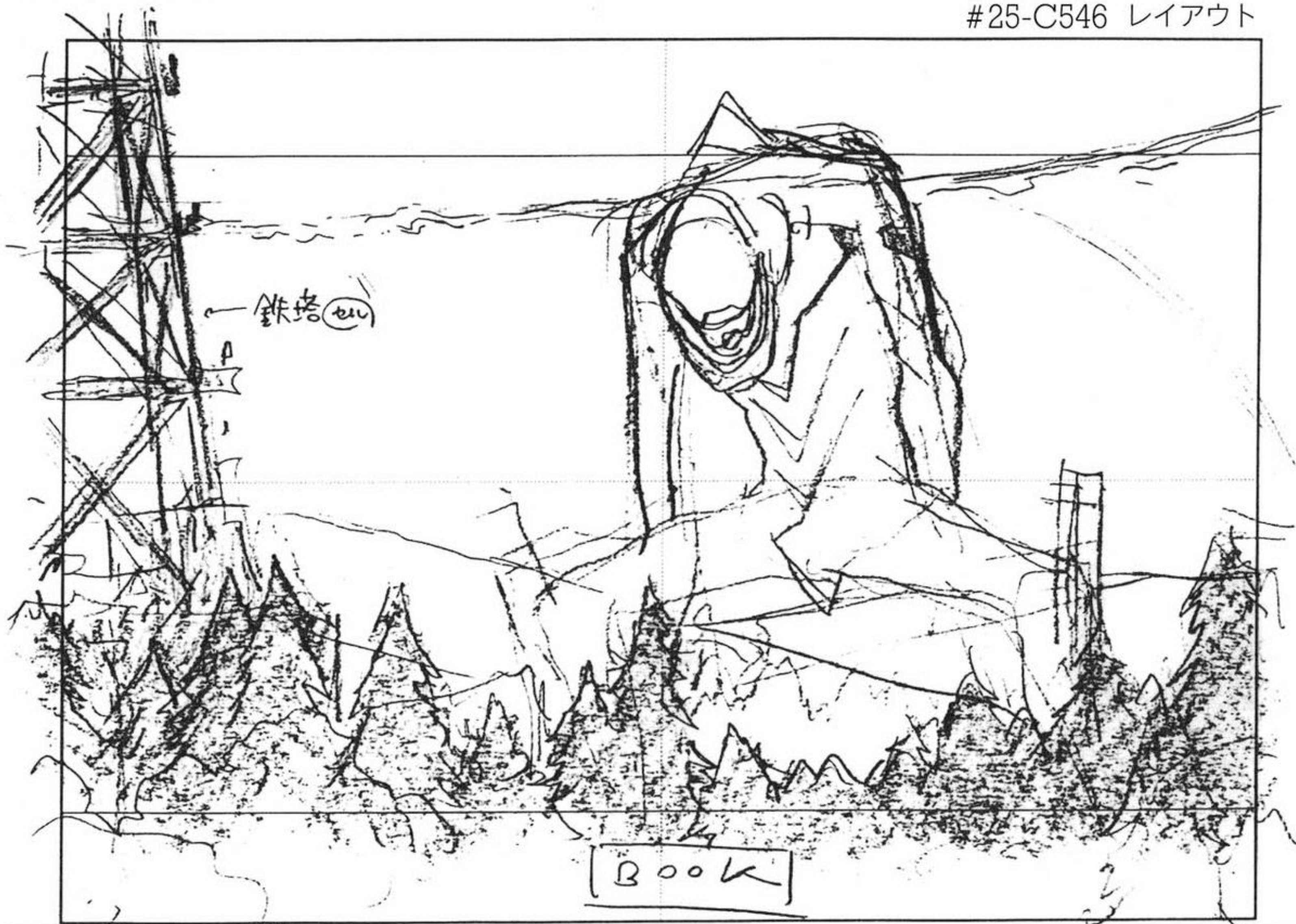

#25-C546

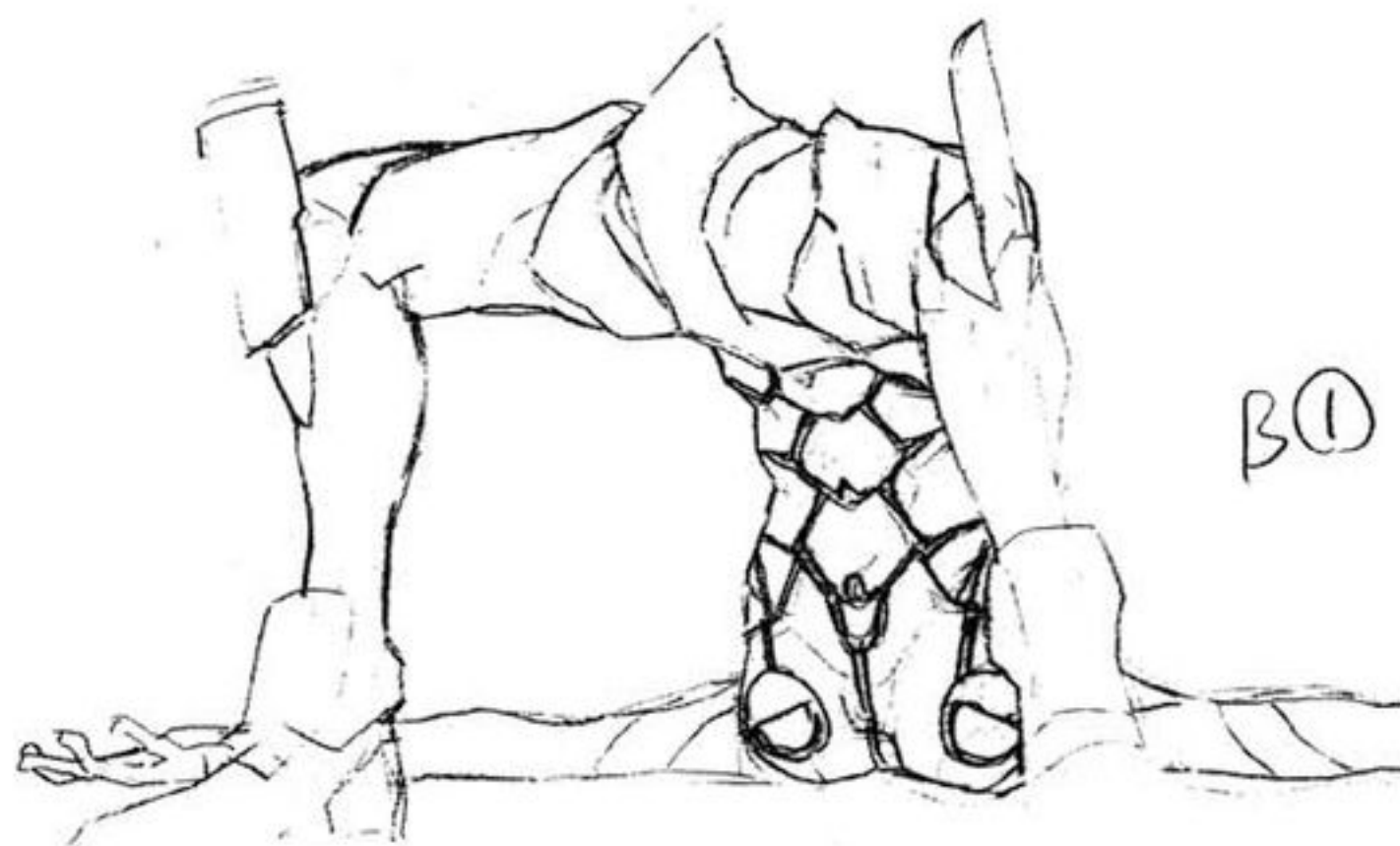
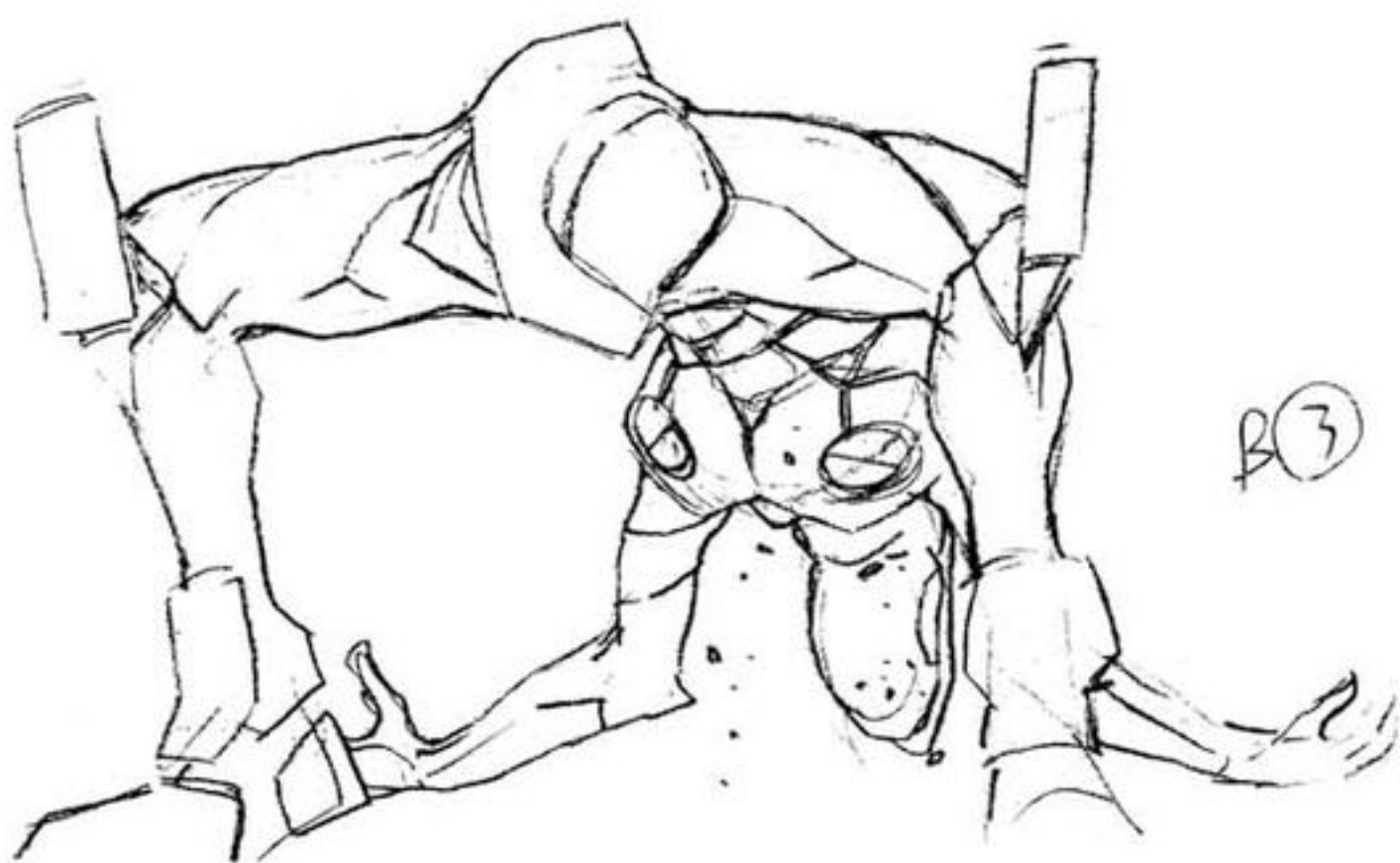



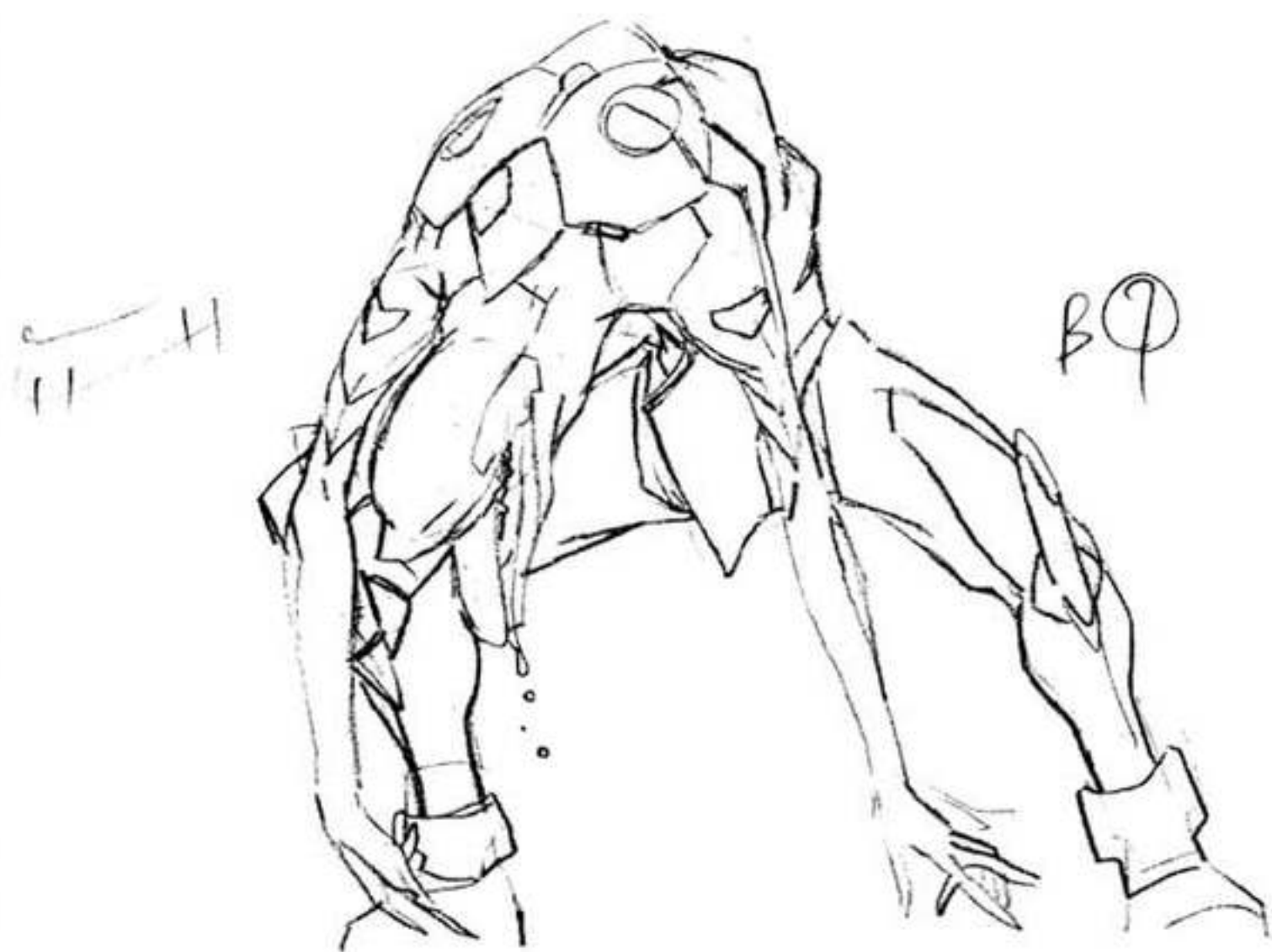
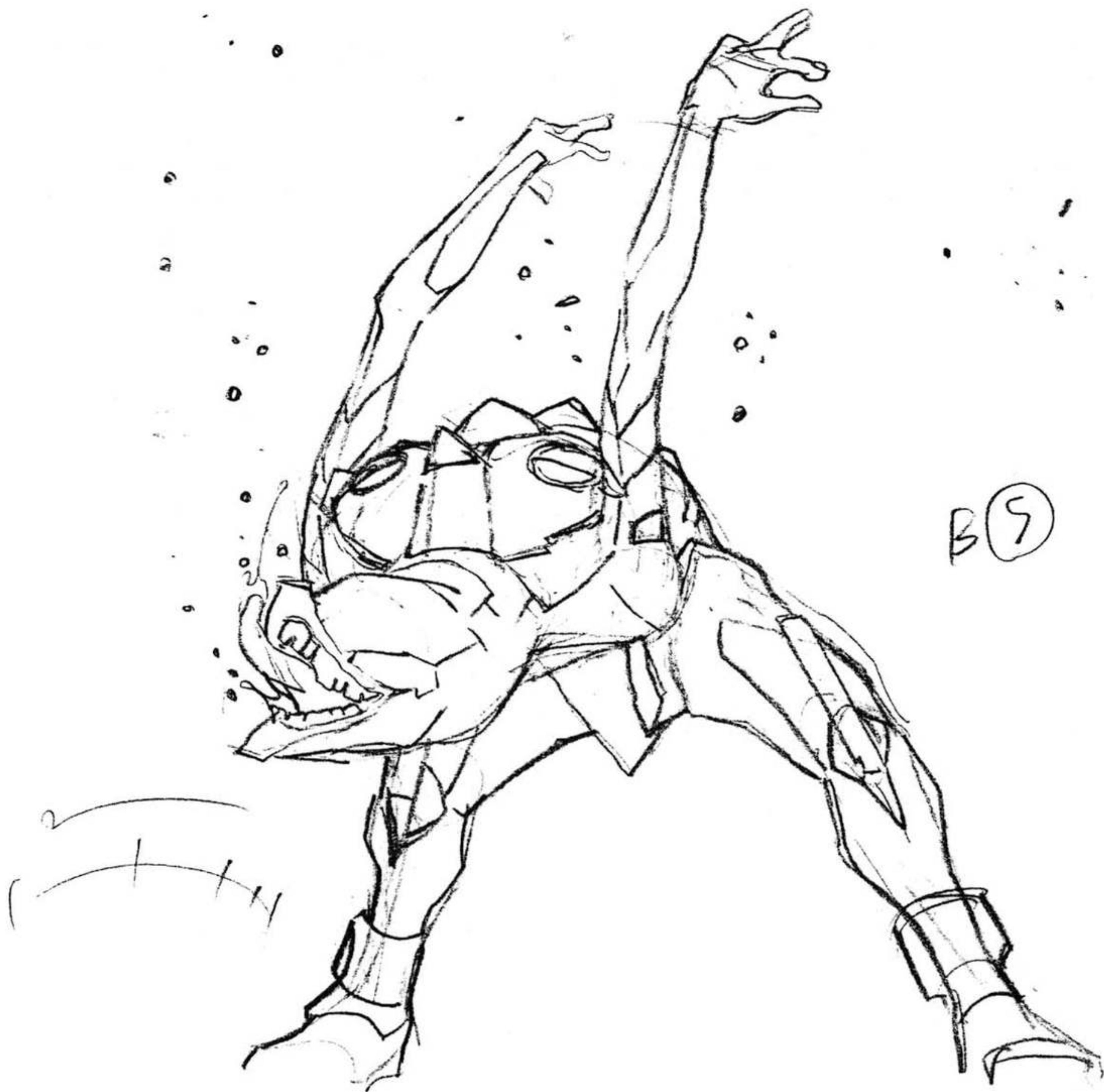



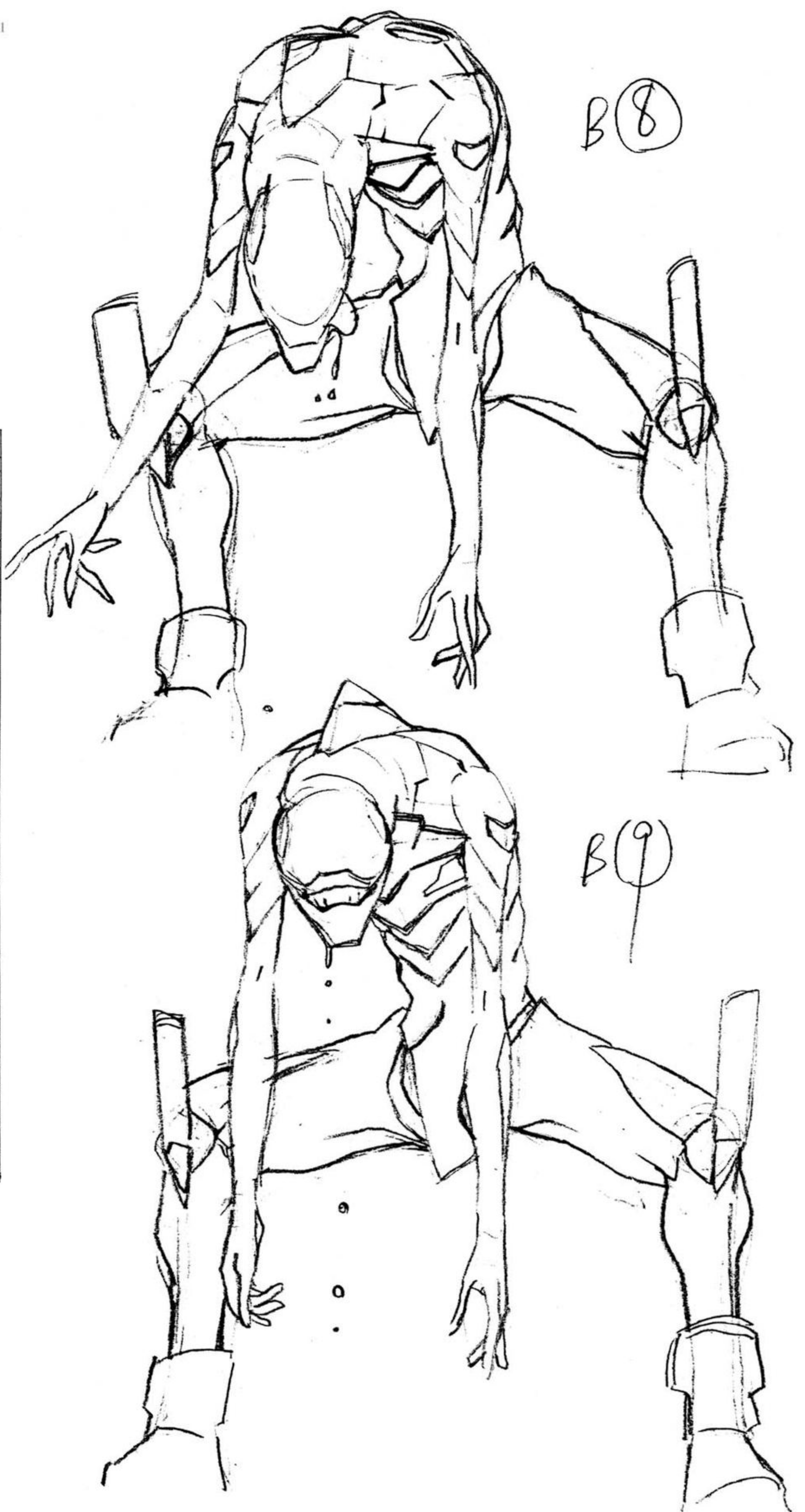

タイムシート

A	B	C		A	B	C	
①	①	①	2	⑥			74
•			4	•			76
			6				78
•			8	•			80
•			10	•			82
			12				84
•			14	②			86
•			16	•			88
②			18	•			90
			20	•			92
•			22	•			94
			24				96
•			26	•			98
•			28	⑧			100
			30				102
③			32	•			104
•			34	•			106
			36				108
•			38	•			110
•			40	•			112
			42				114
•			44	•			116
•			46	•			118
			48				120
④			50	⑨			122
•			52				
			54				
•			56				
⑤			58				
•			60				
⑤			62				
•			64				
			66				
•			68				
			70				
			72				



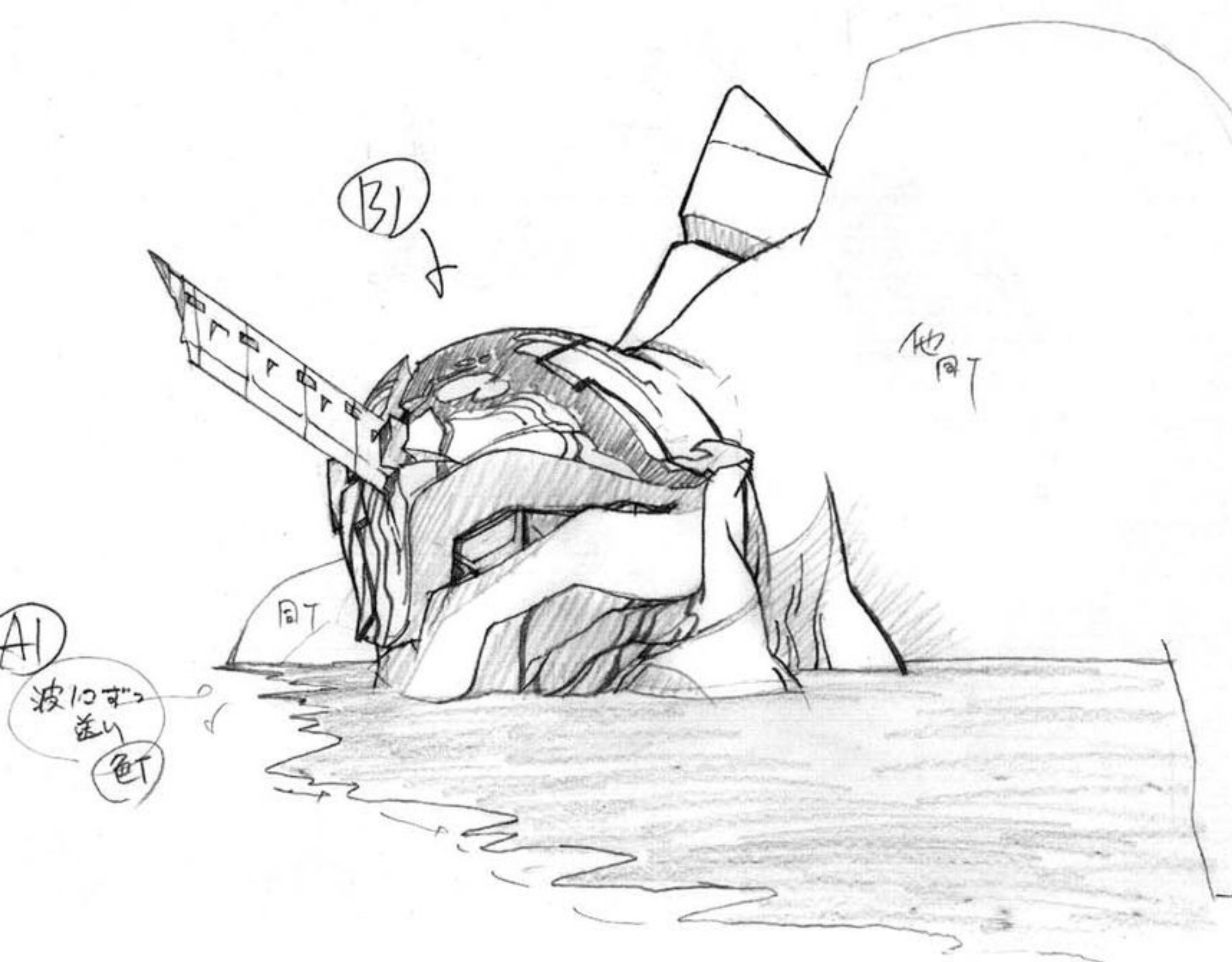

#25-C547



(A2)  
2'??  
|||||



A1  
2'??  
RA23

#25-C549



#25-C551

A0  
△修正あり



A1



A3



A2

修正原画

修正原画

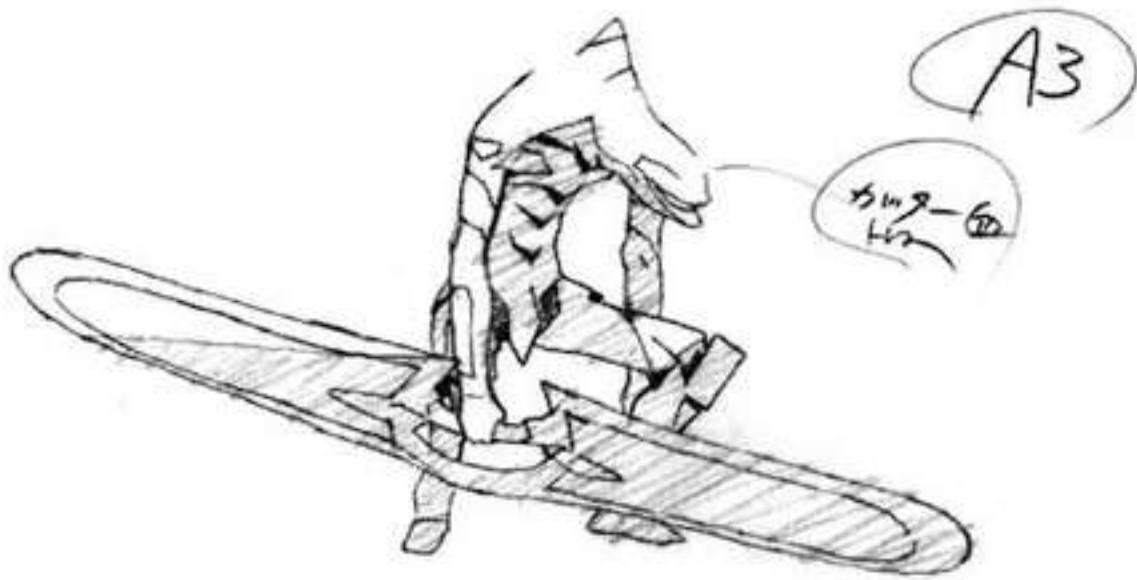

A3

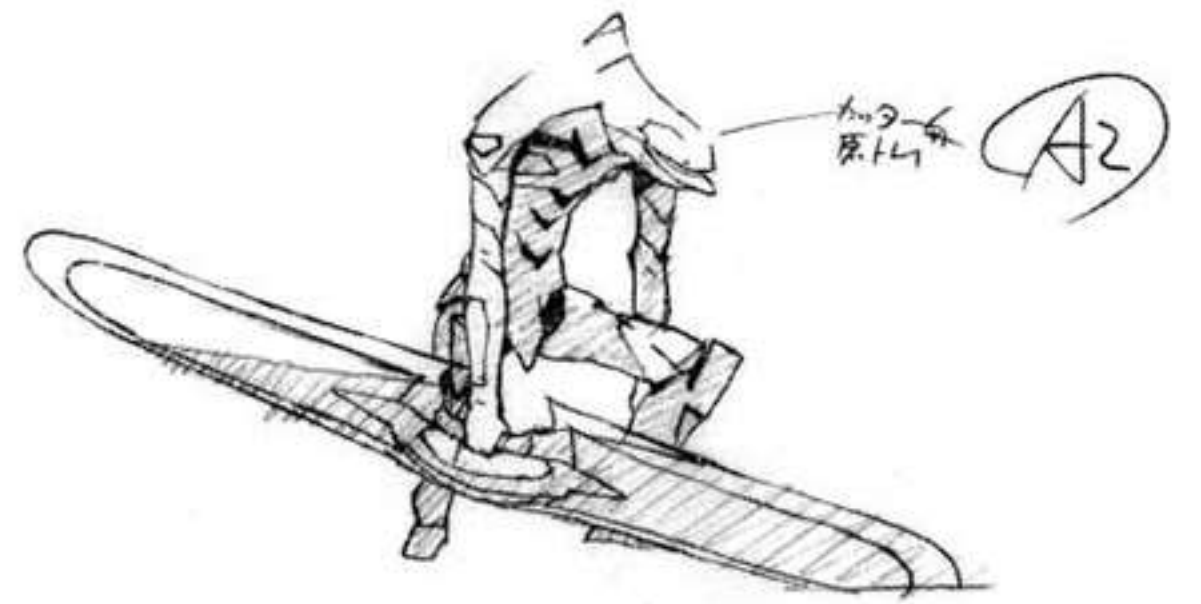

A2



A1



A2



A④

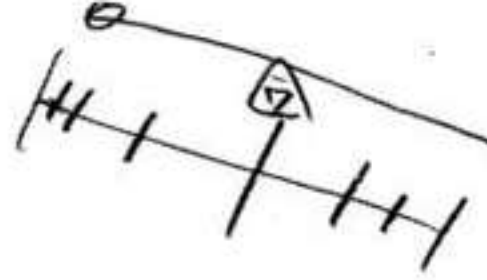

修正原画

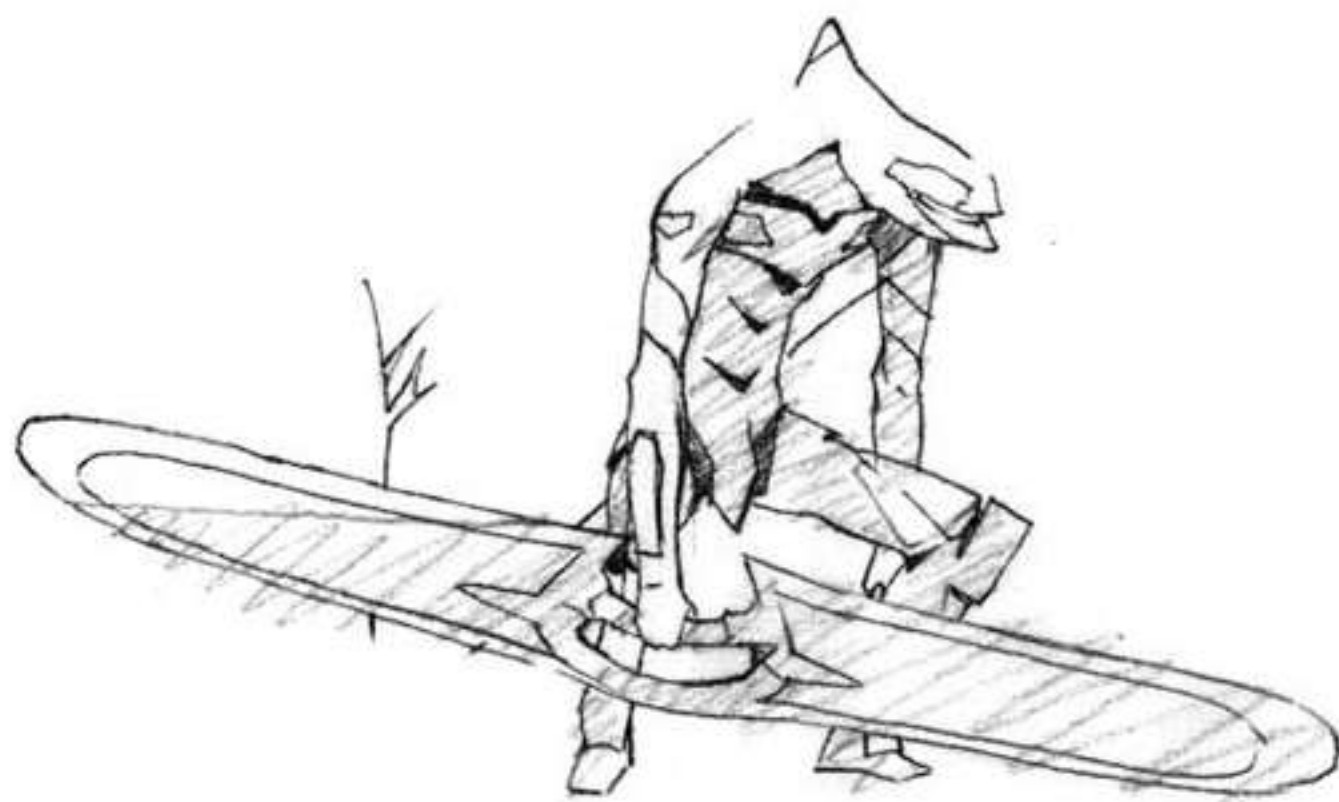

A⑤

修正地

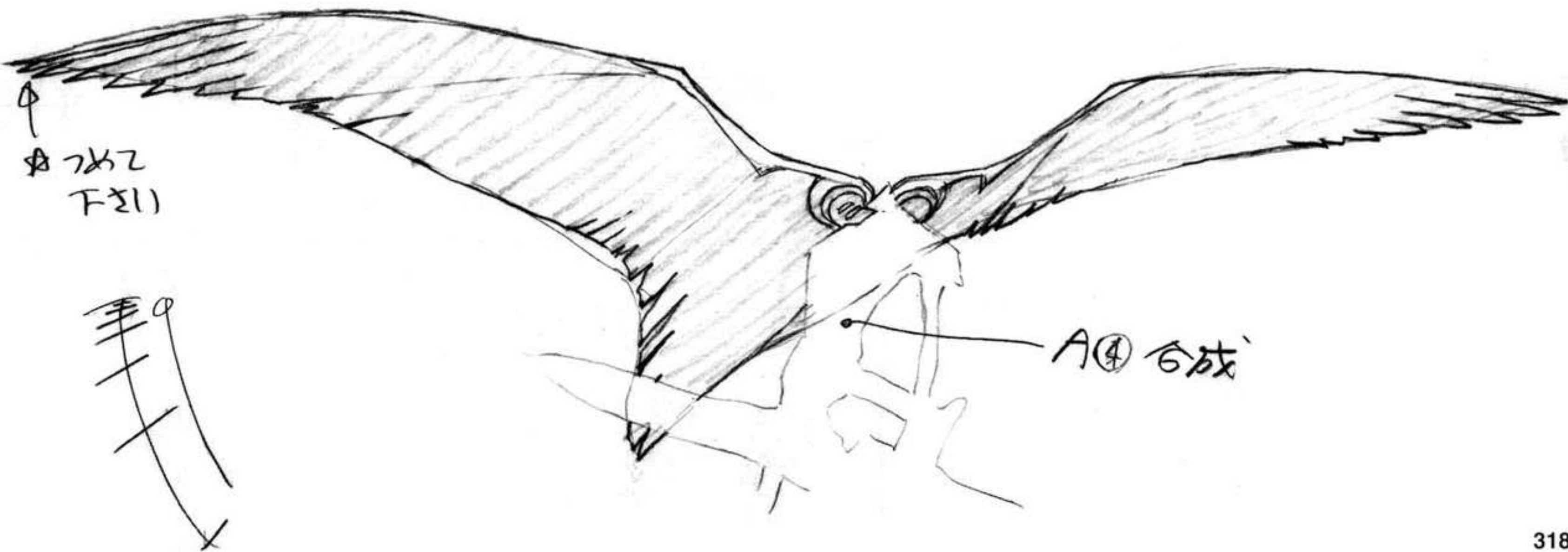





B21



(B1)

修正原画



B21  
修正に合わせ

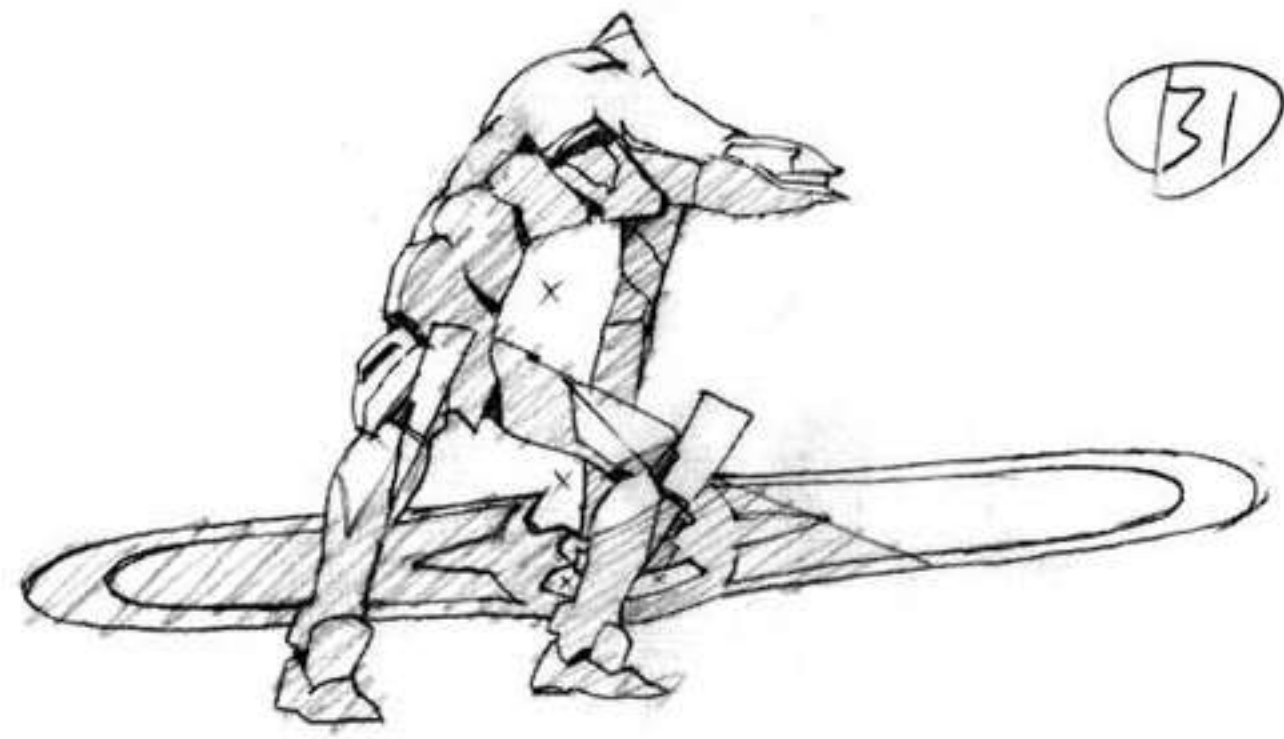

(B1)



(B3)



(B2)

修正原画

修正原画

修正原画

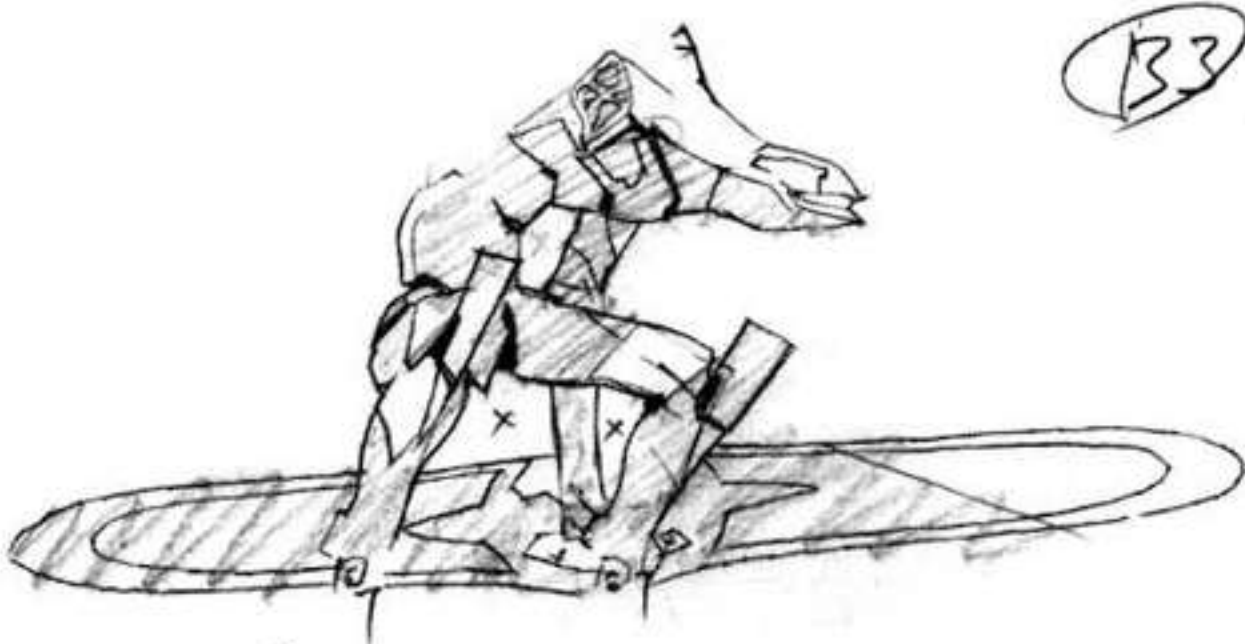

(B3)

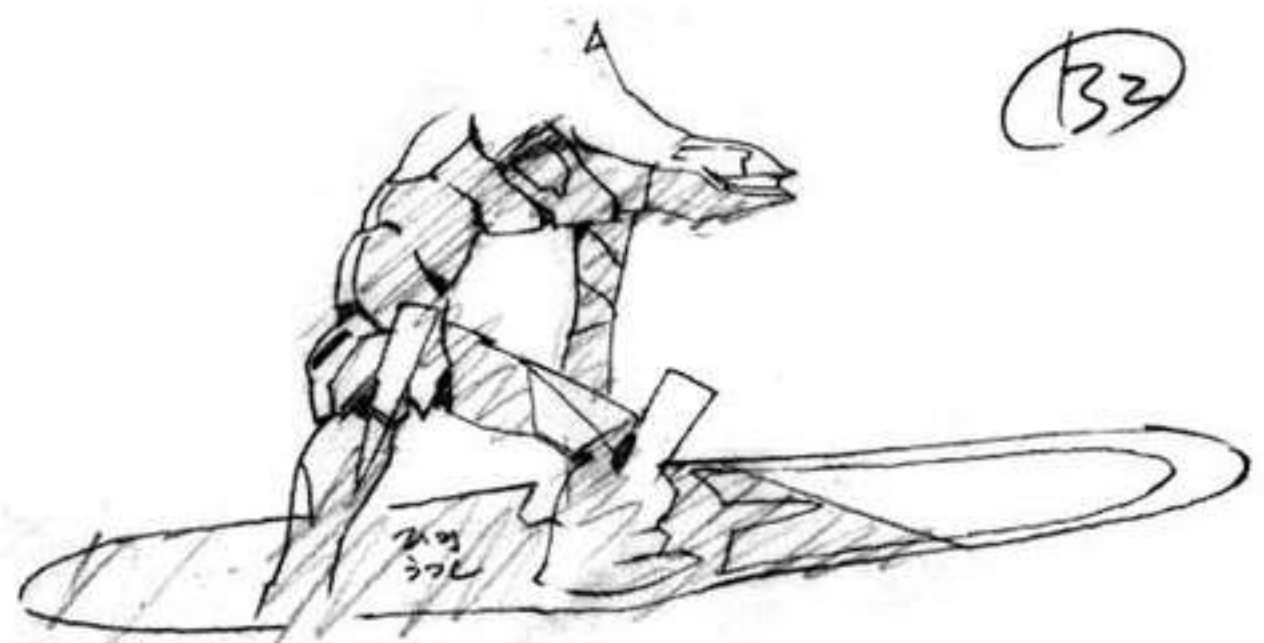

(B2)



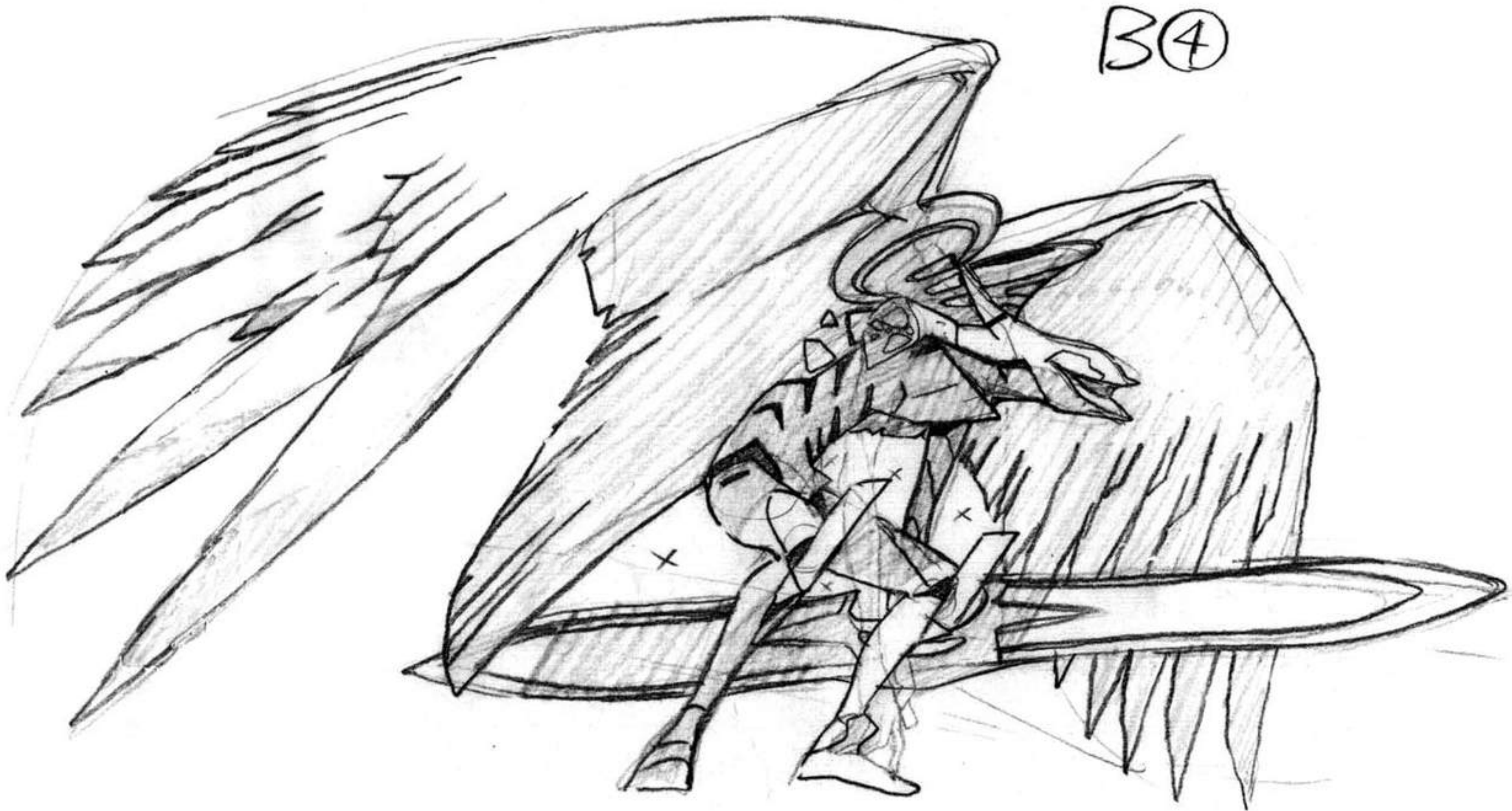

11 | 1 | 11

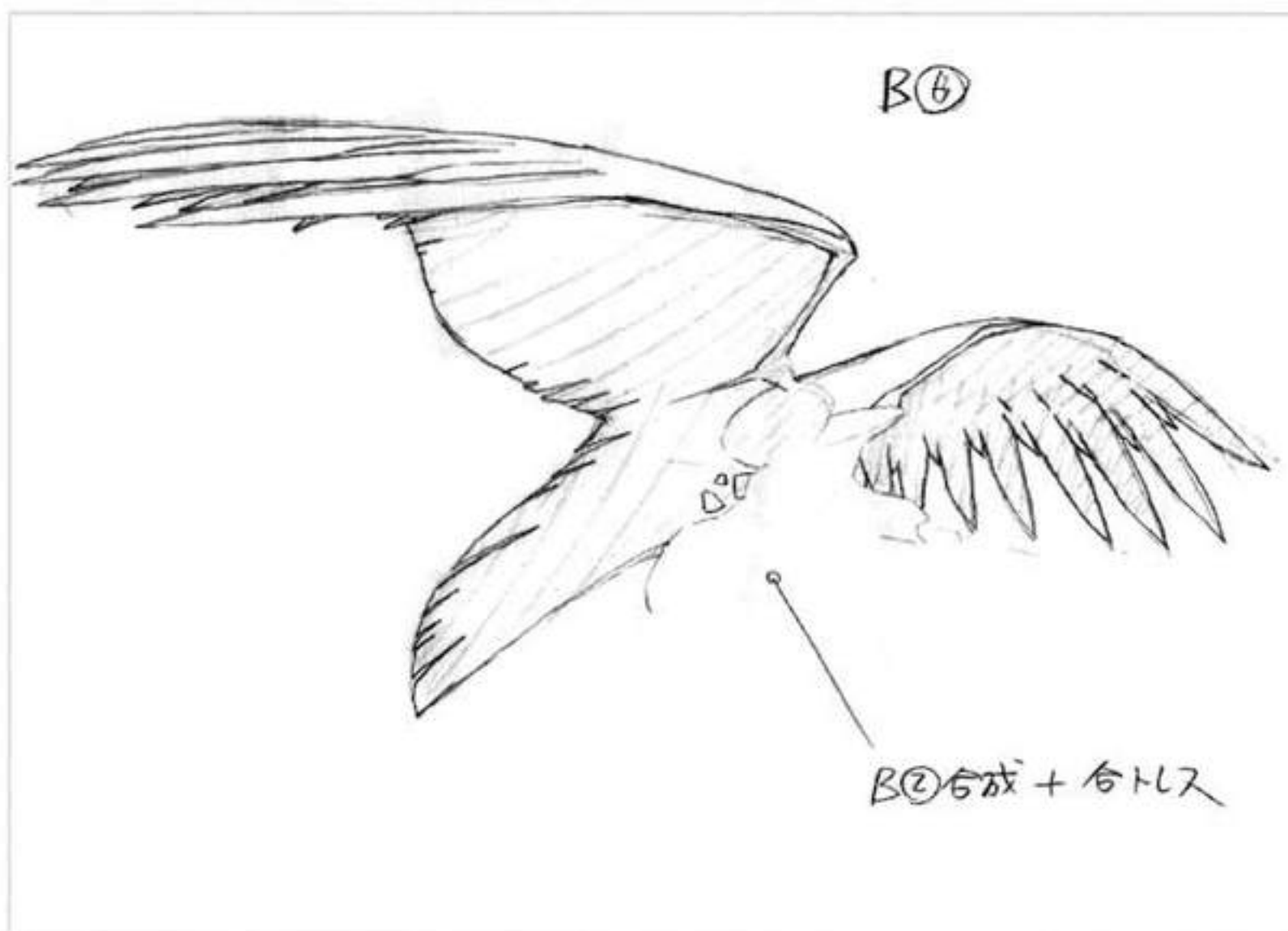

B6

B6合成+合上

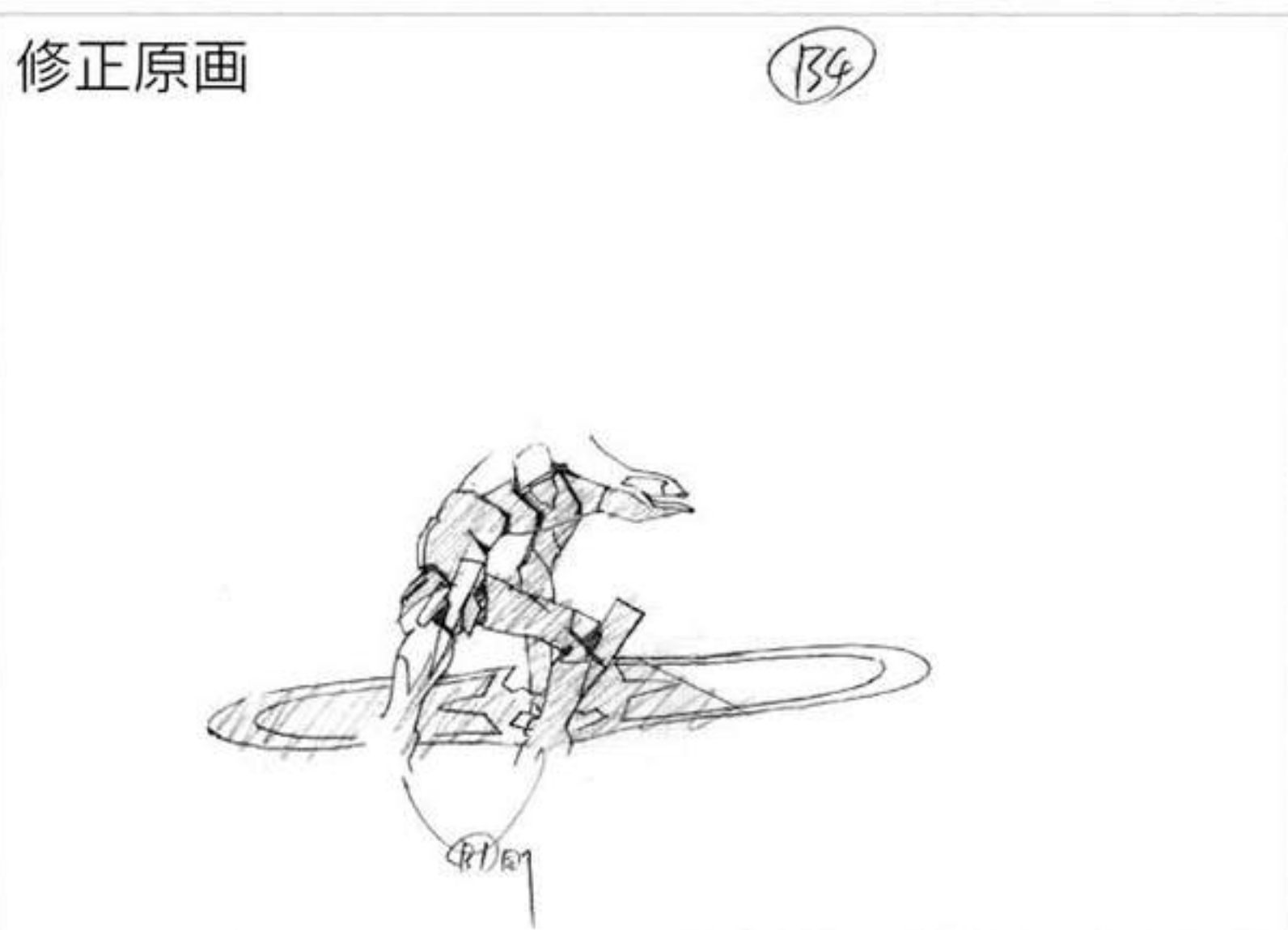

修正原画

B4

#25-C551

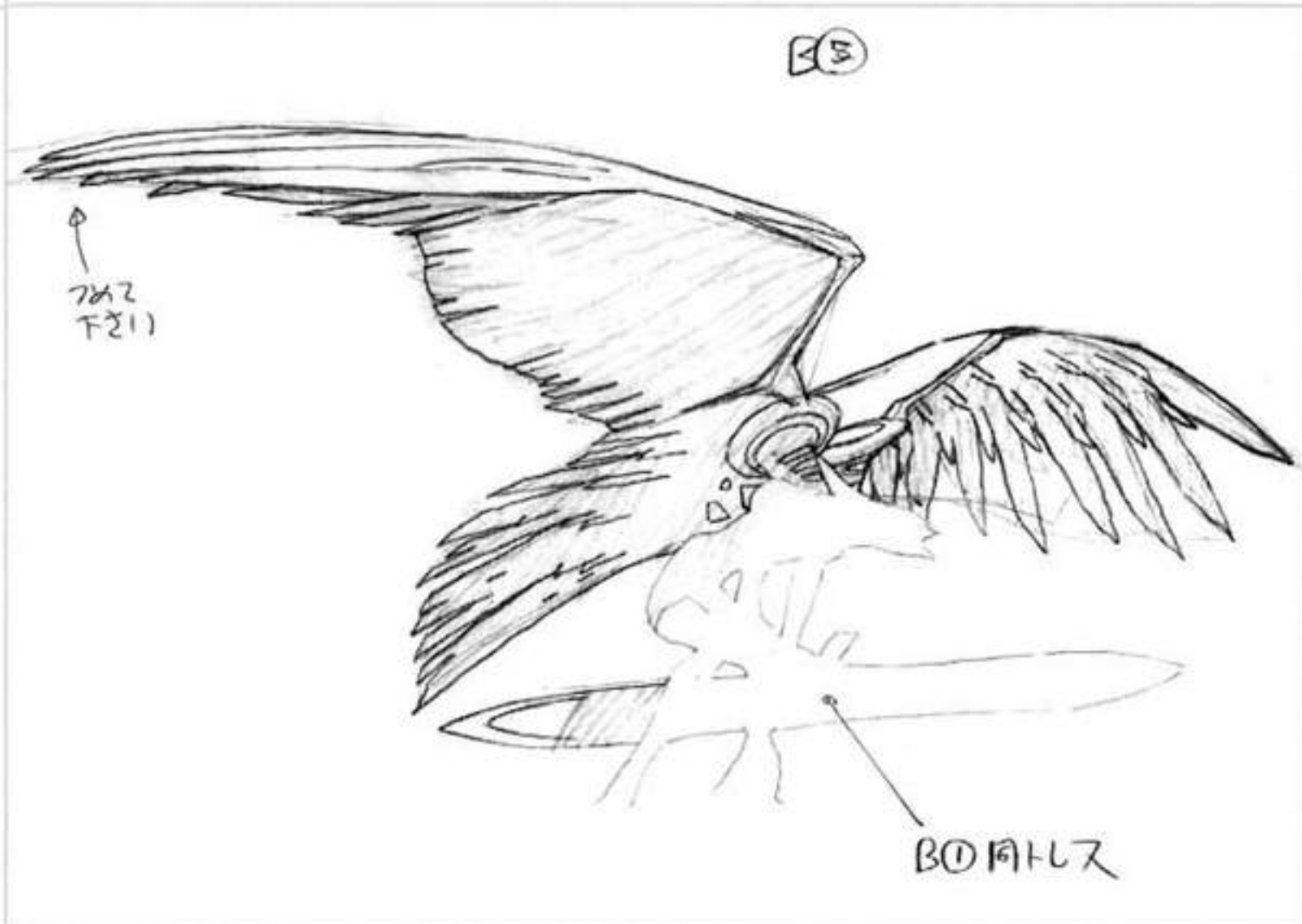

B5

702  
F211

B0合上







ABC	①	②	
			2
			4
②			6
③			8
			10
④			12
			14
			16
			18
			20
③			22
			24
			26
④			28
			30

タイムシート

			32
			34
④			36
②			38
③			40
			42
④			44
			46
			48
			50
			52
③			54
			56
⑤			58
			60
			62
			64
④			66
			68
			70
			72
			74
			76
			78
			80
			82
			84
			86
			88
			90
			92
			94
			96
			98
			100
⑤	④		102
			104
			106
			108
			110
			112
			114
			116
			118
			120

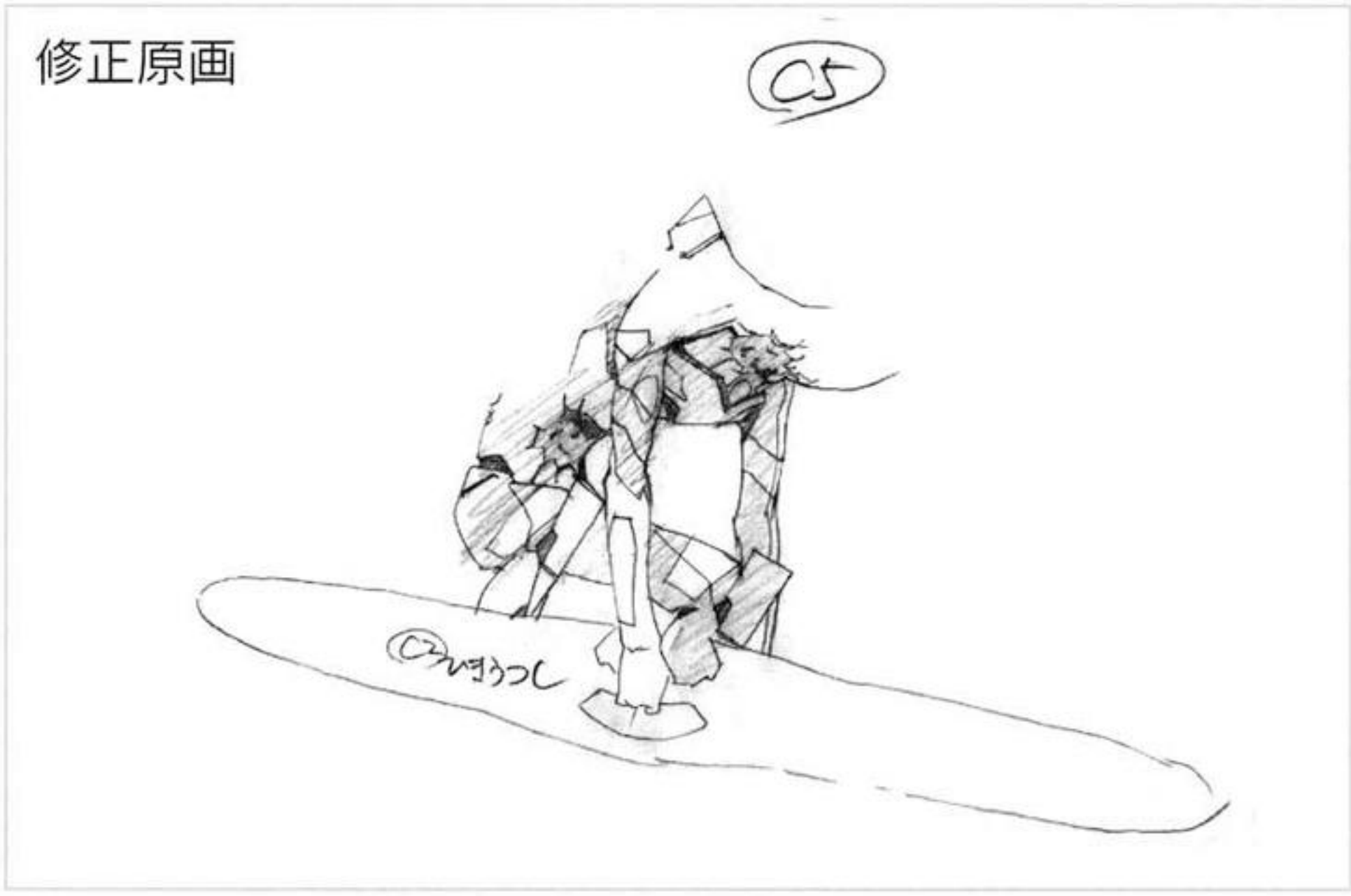

#25-C551





#25-C552,567



修正原画



A ④ / ④  
A 2 ④  
.....  
↑



A 2 ④



④ ↑

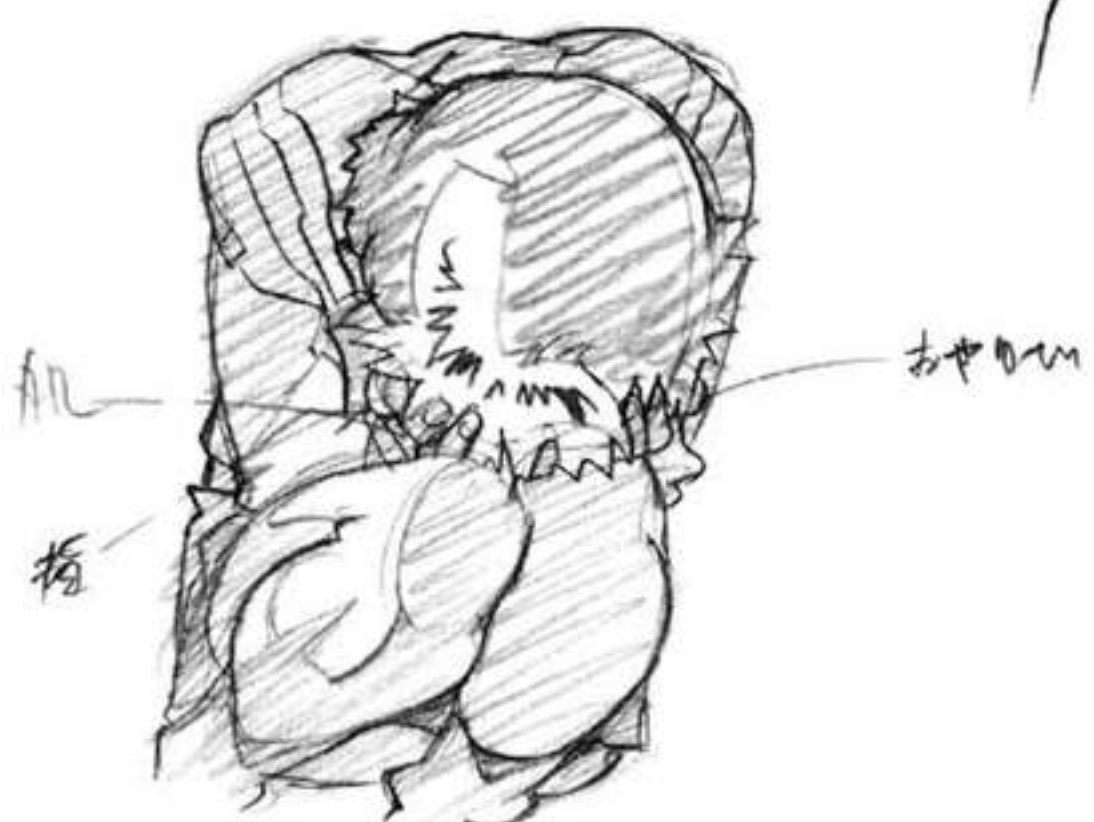

A ⑤ / ⑤  
6 ⑤



A 3 ④







#25-C552,567







#25-C552,567

修正原画





A①) 同ルズ

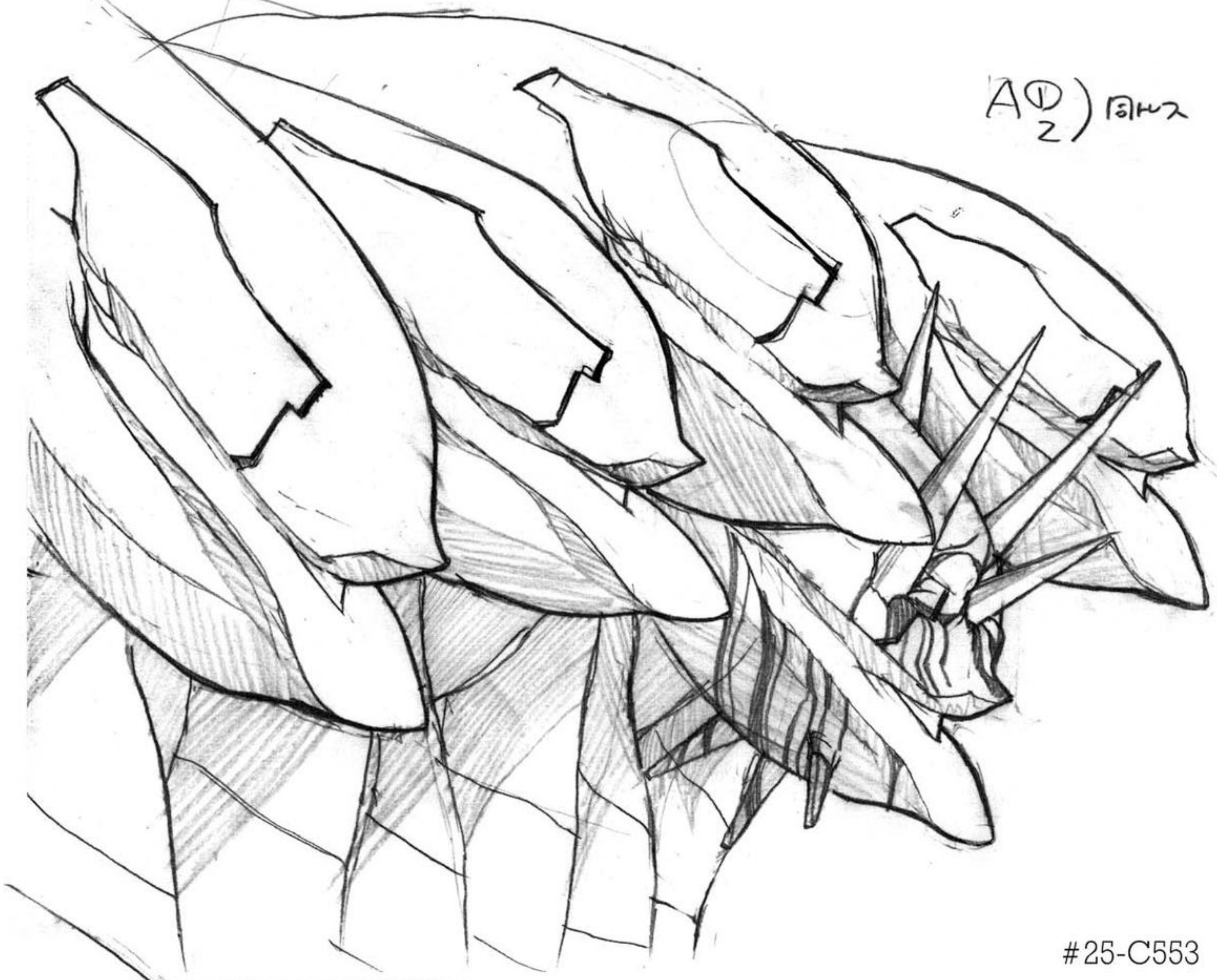

#25-C553

A③.

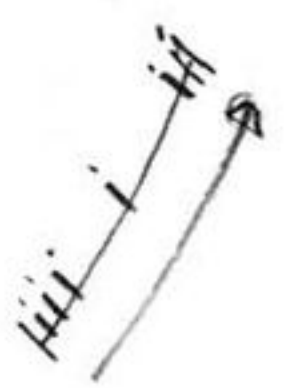
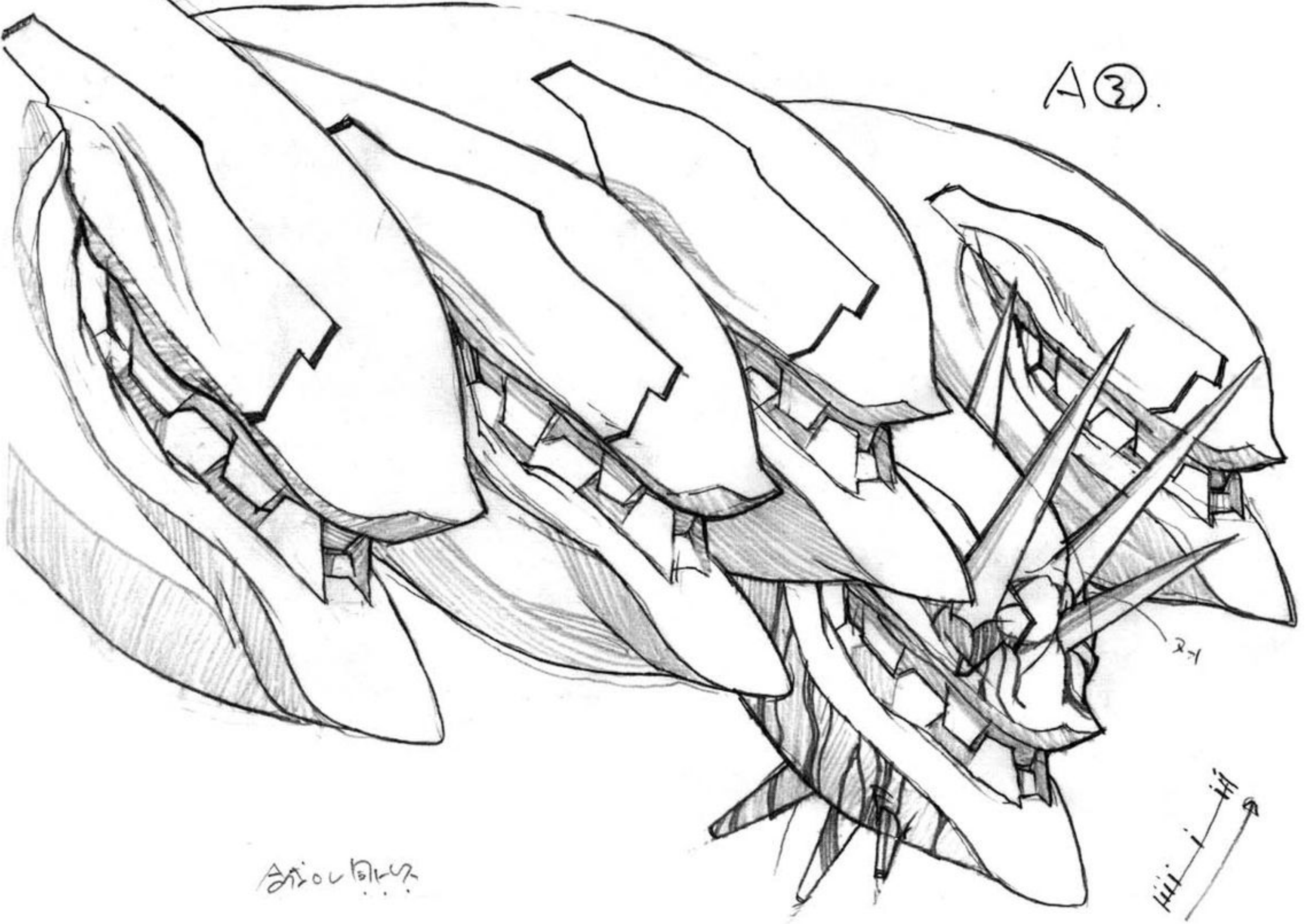

同ルズ





#25-C555

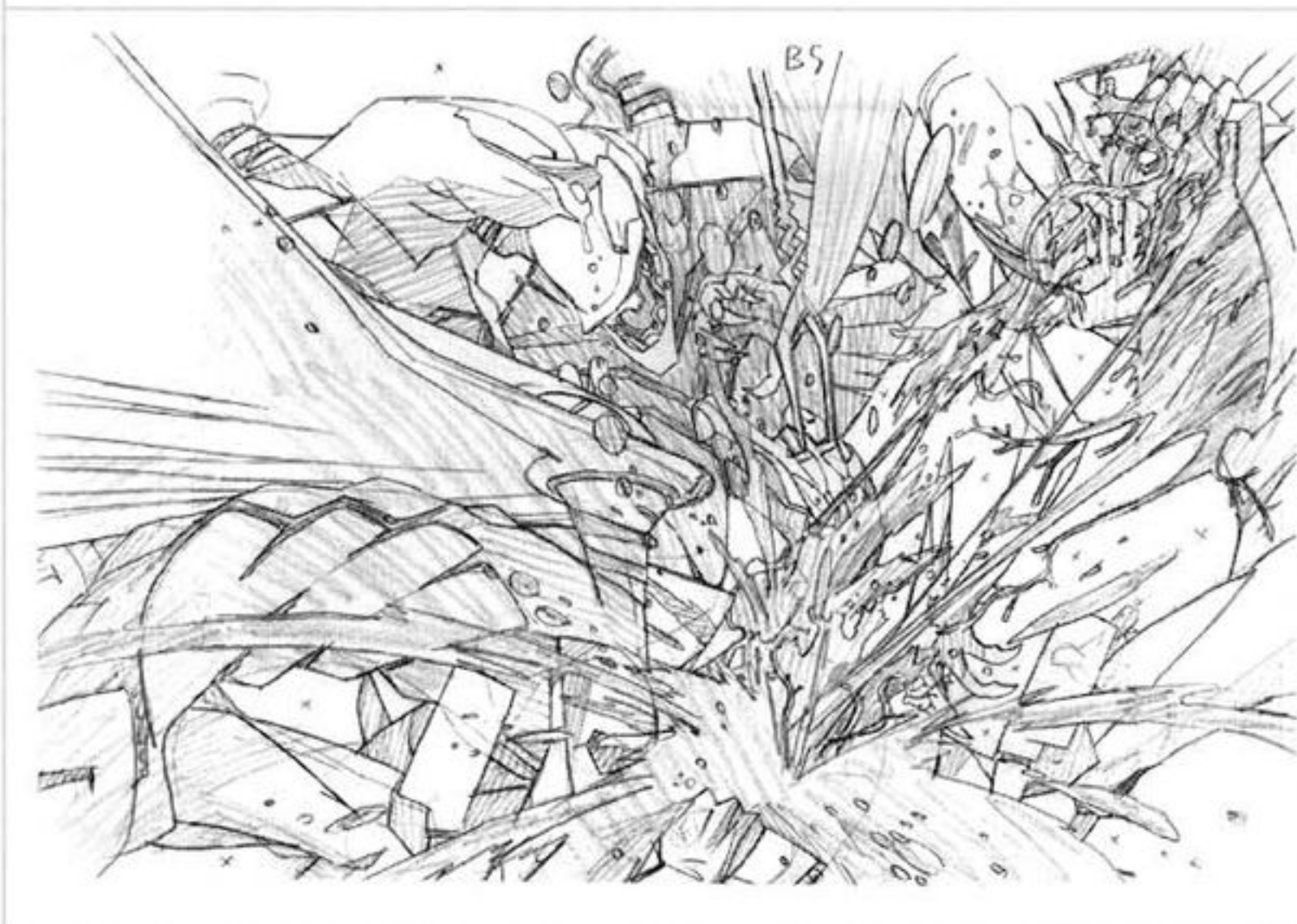
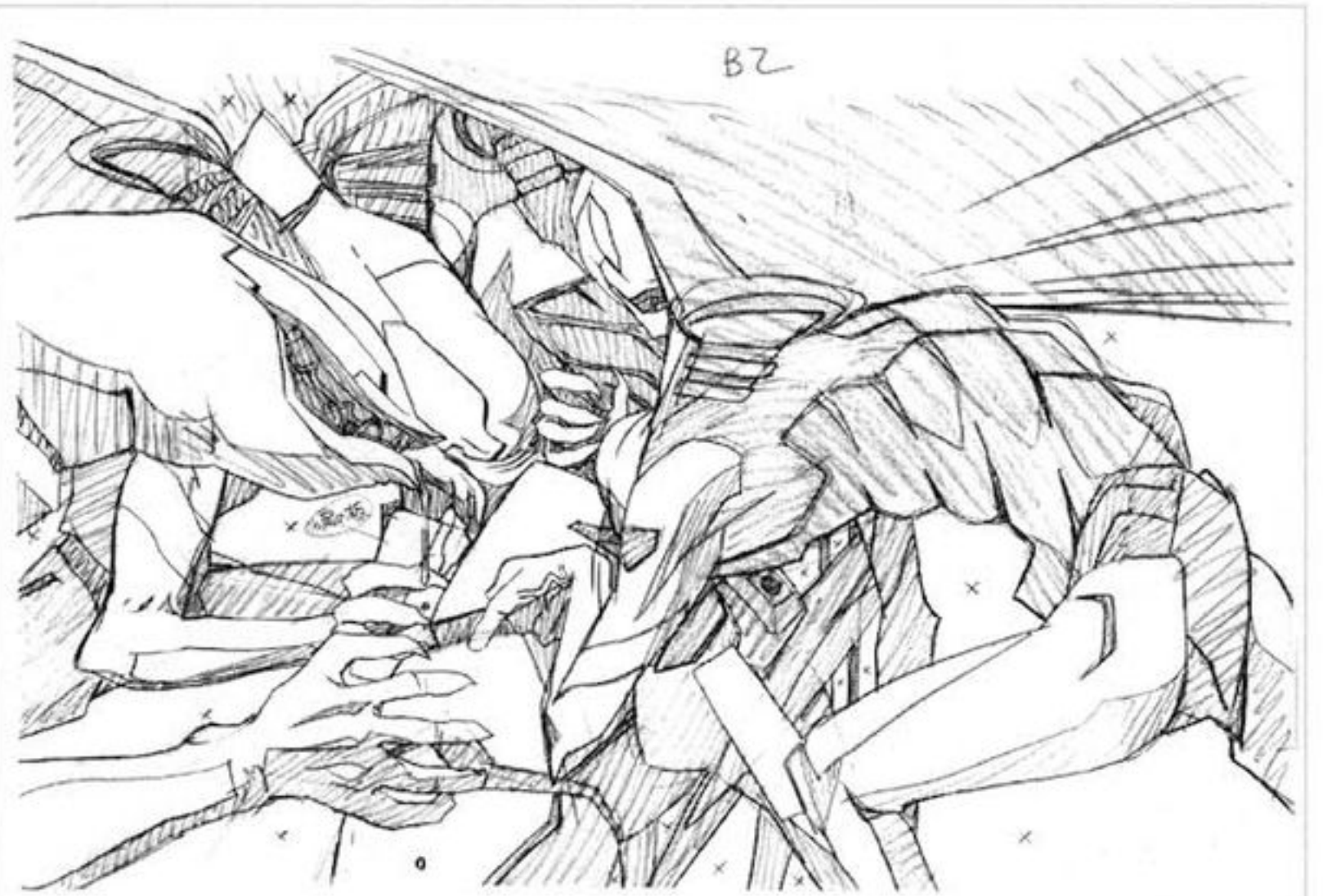



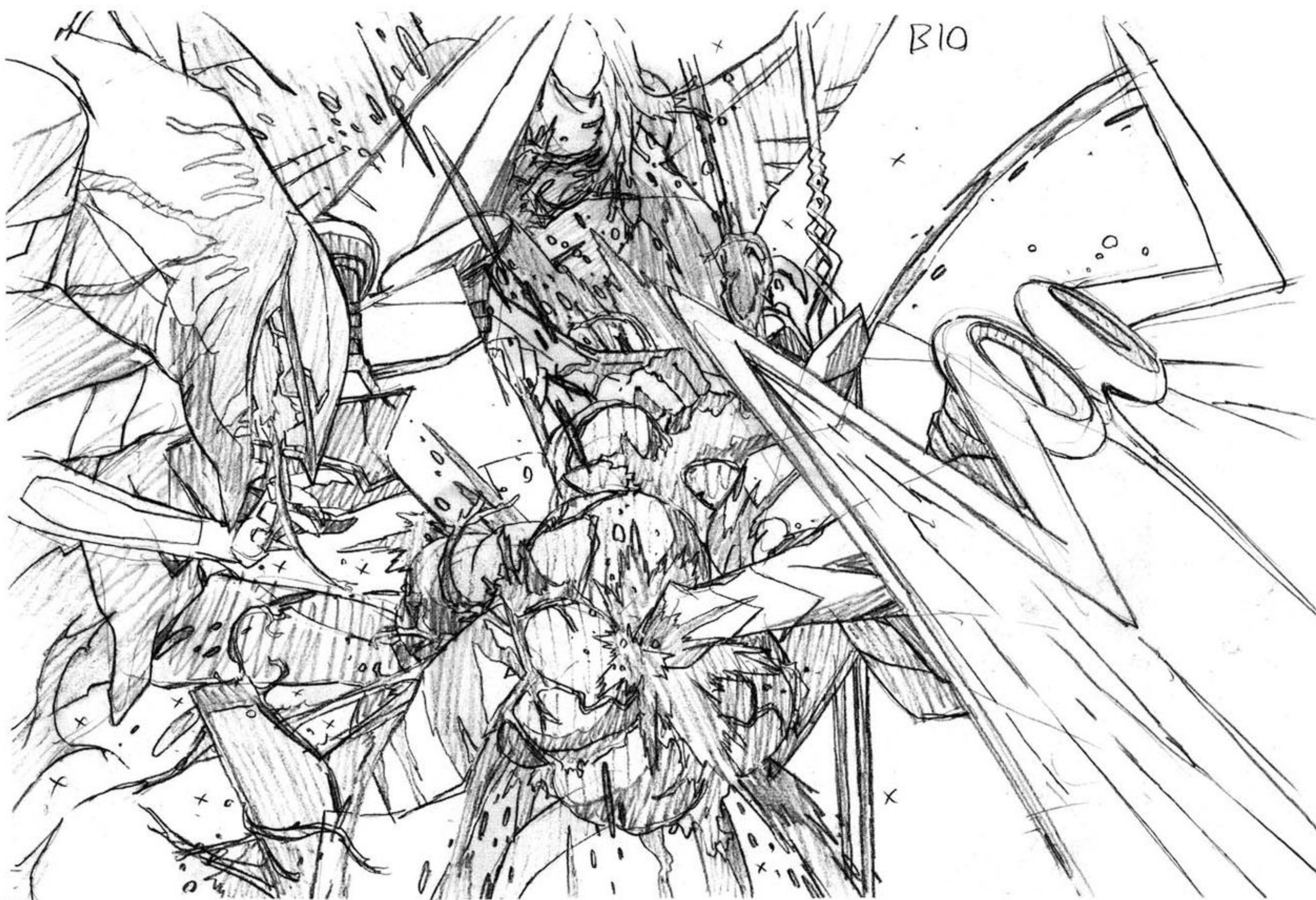



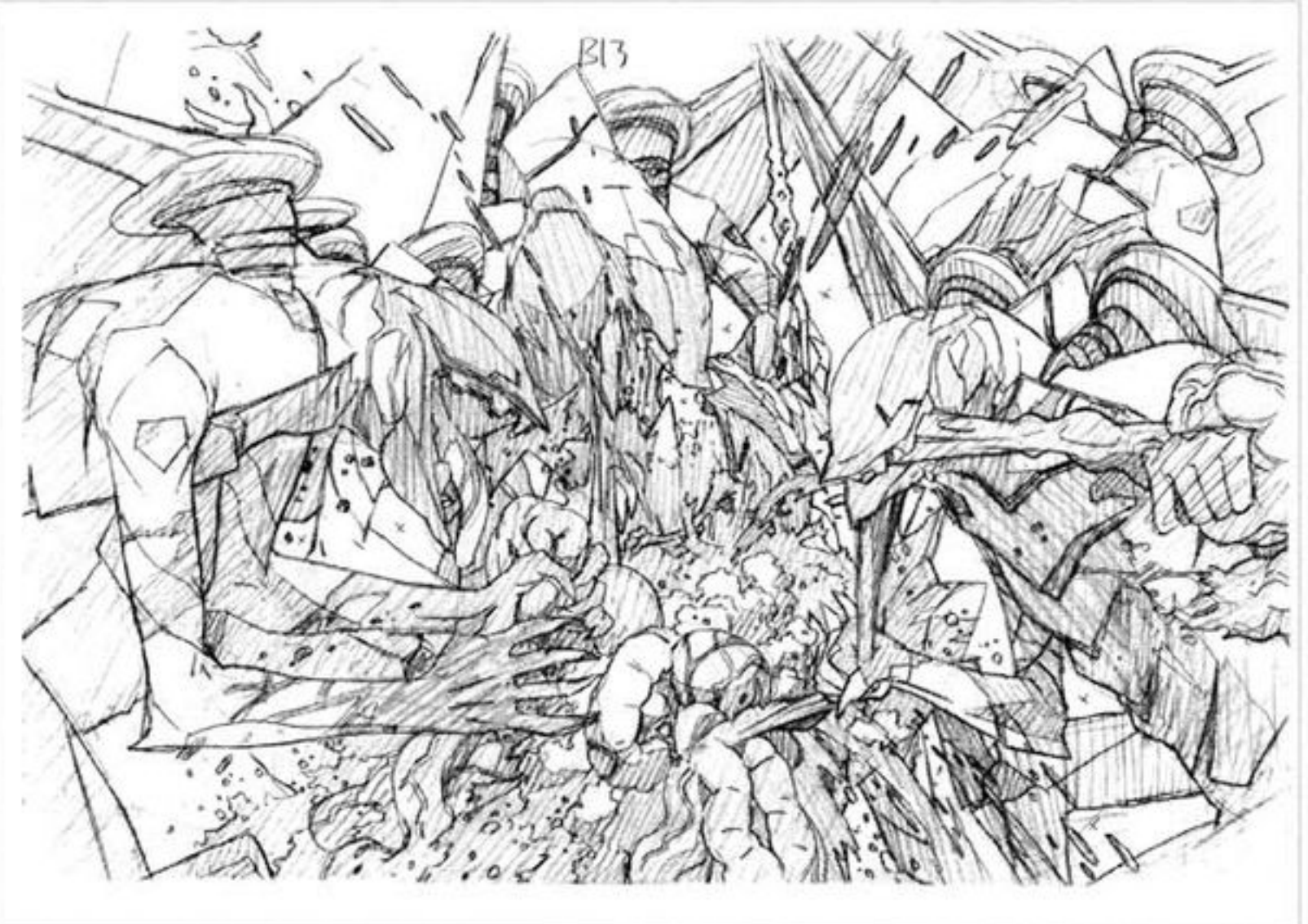
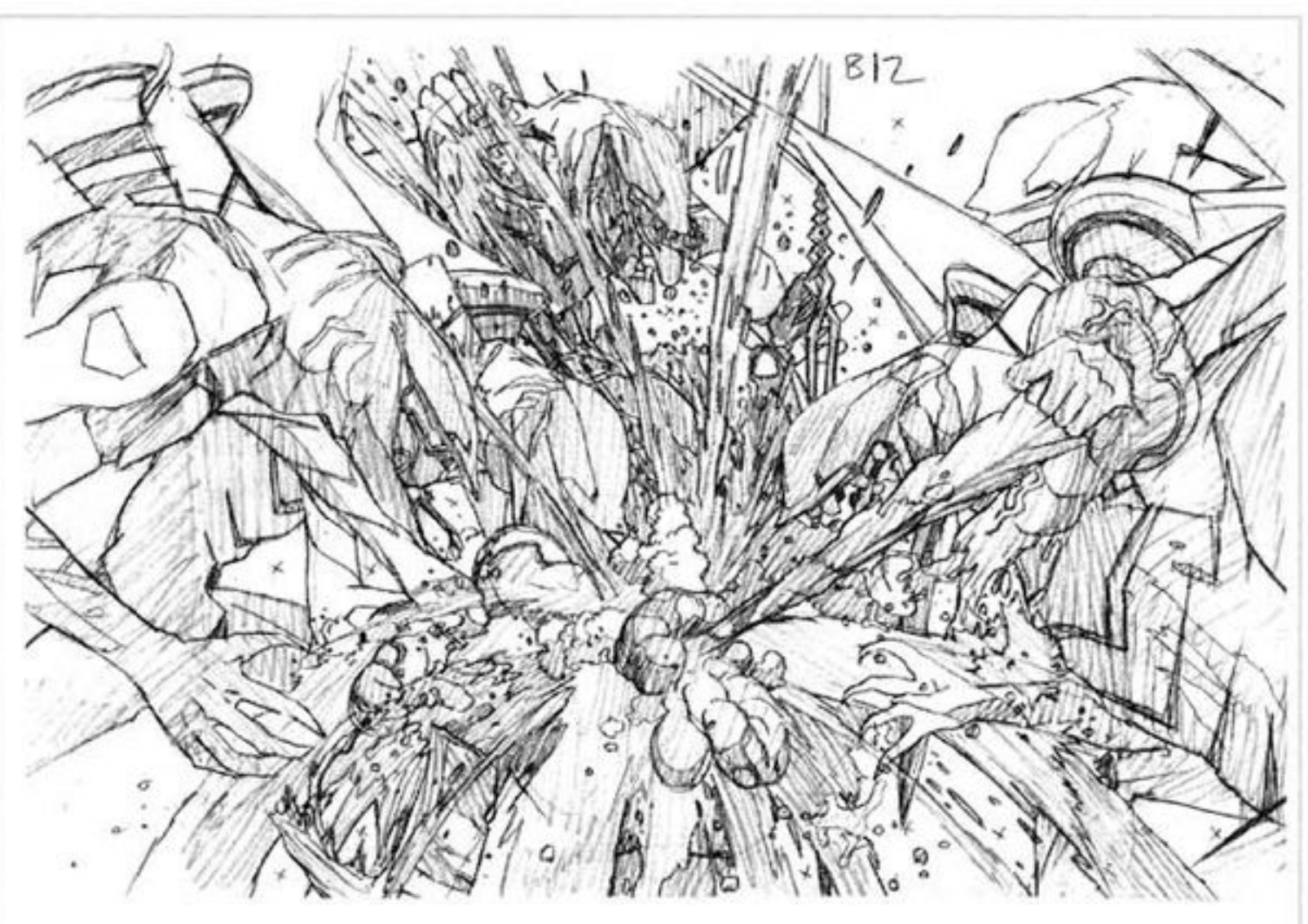
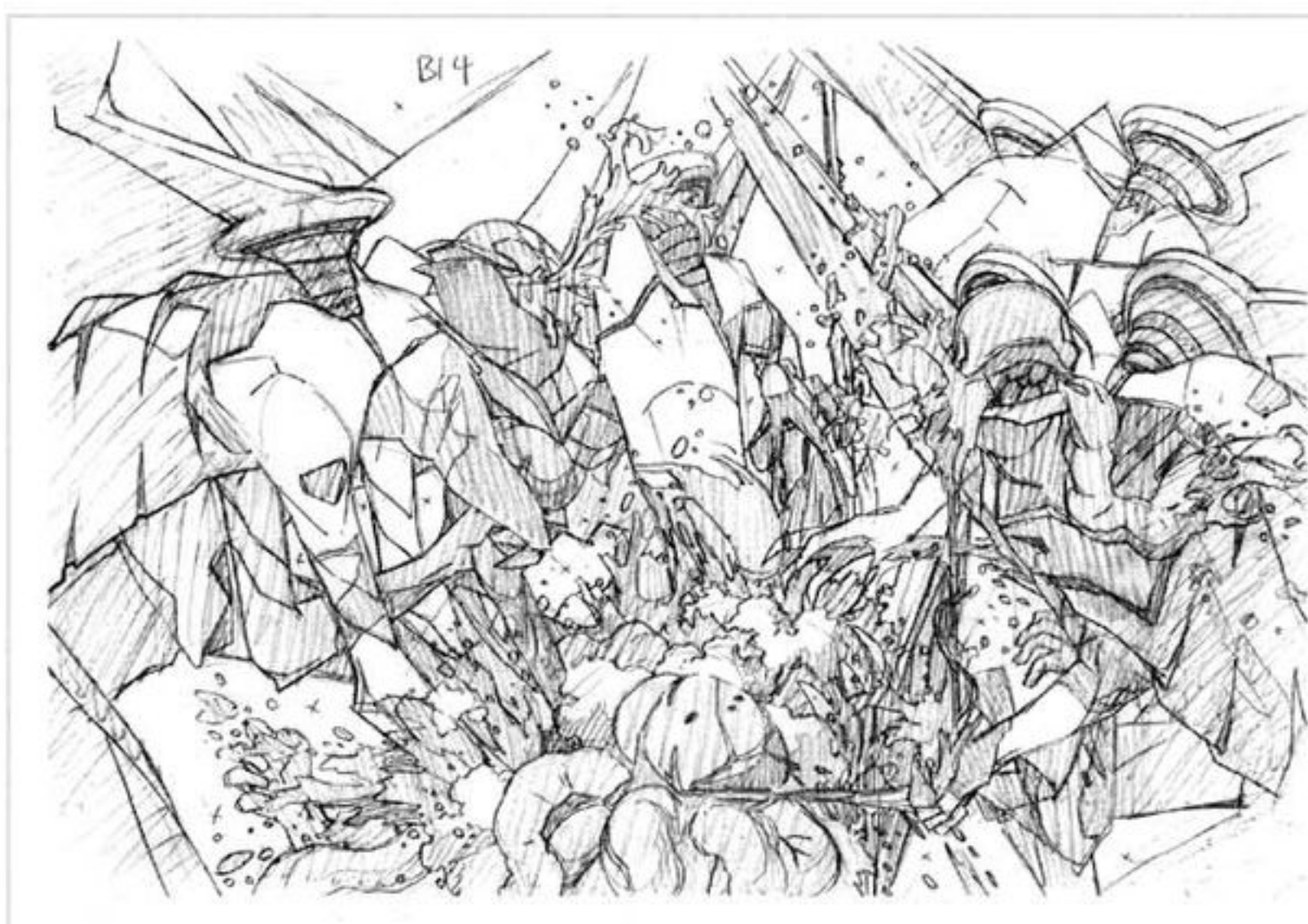



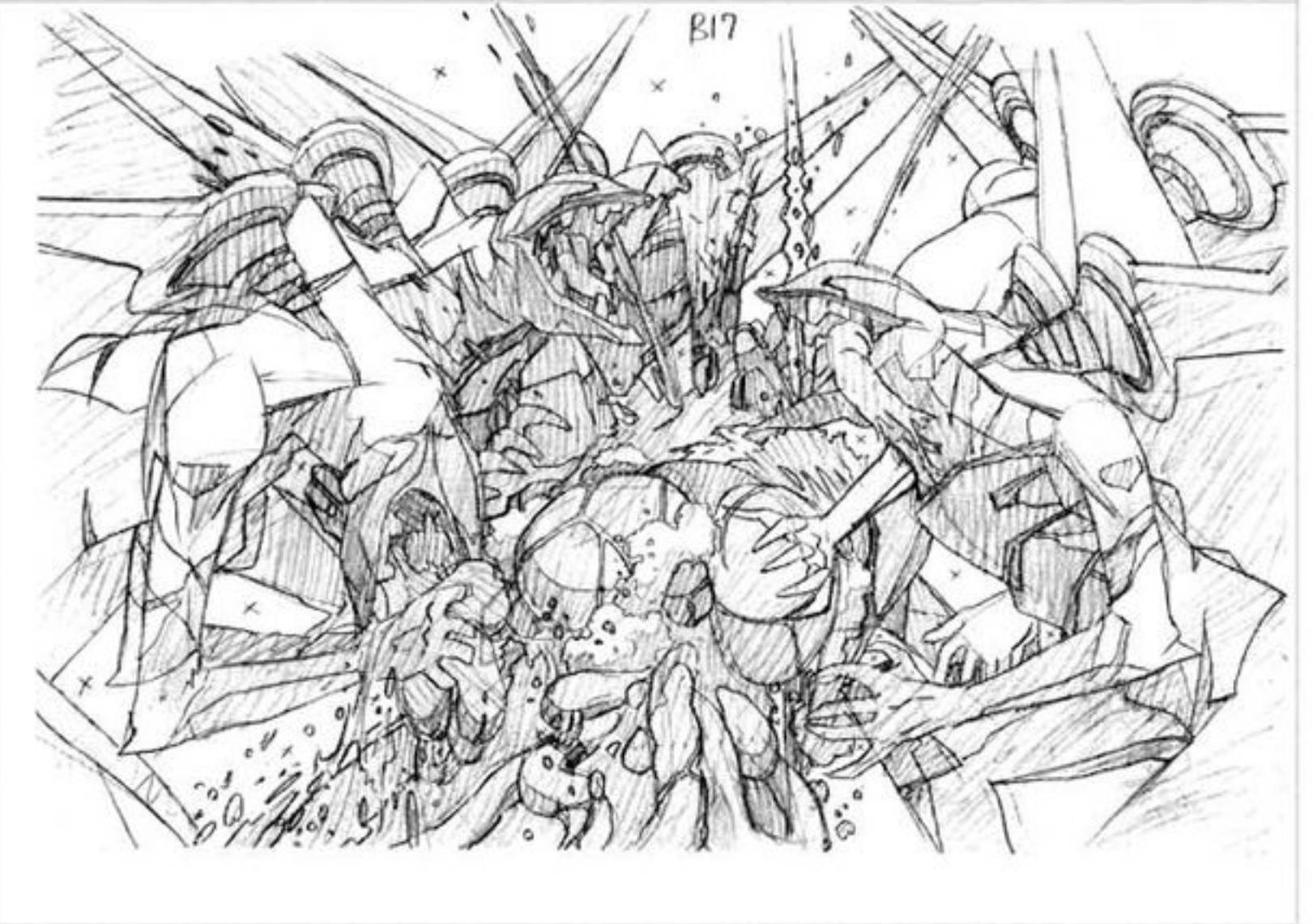
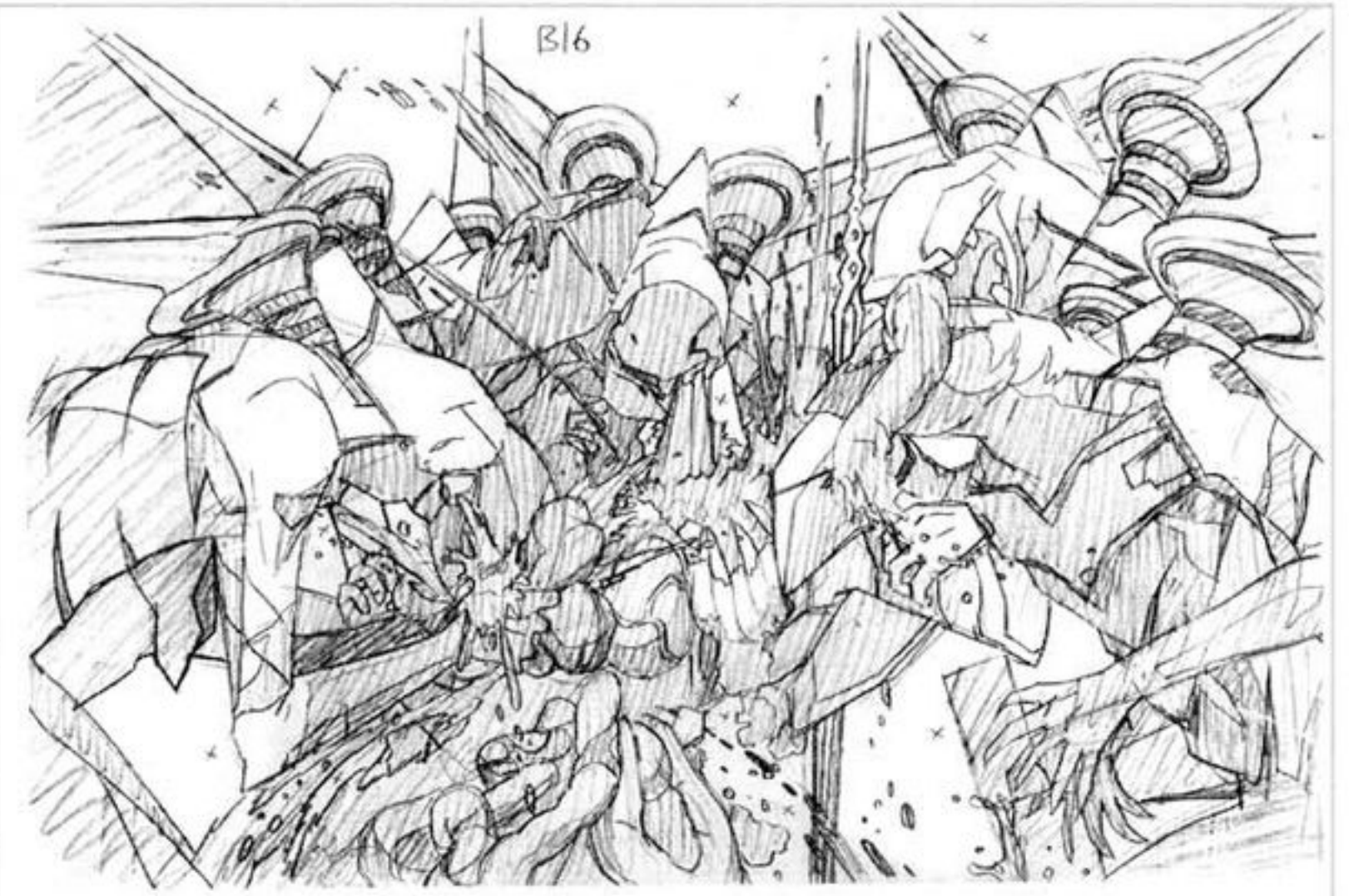
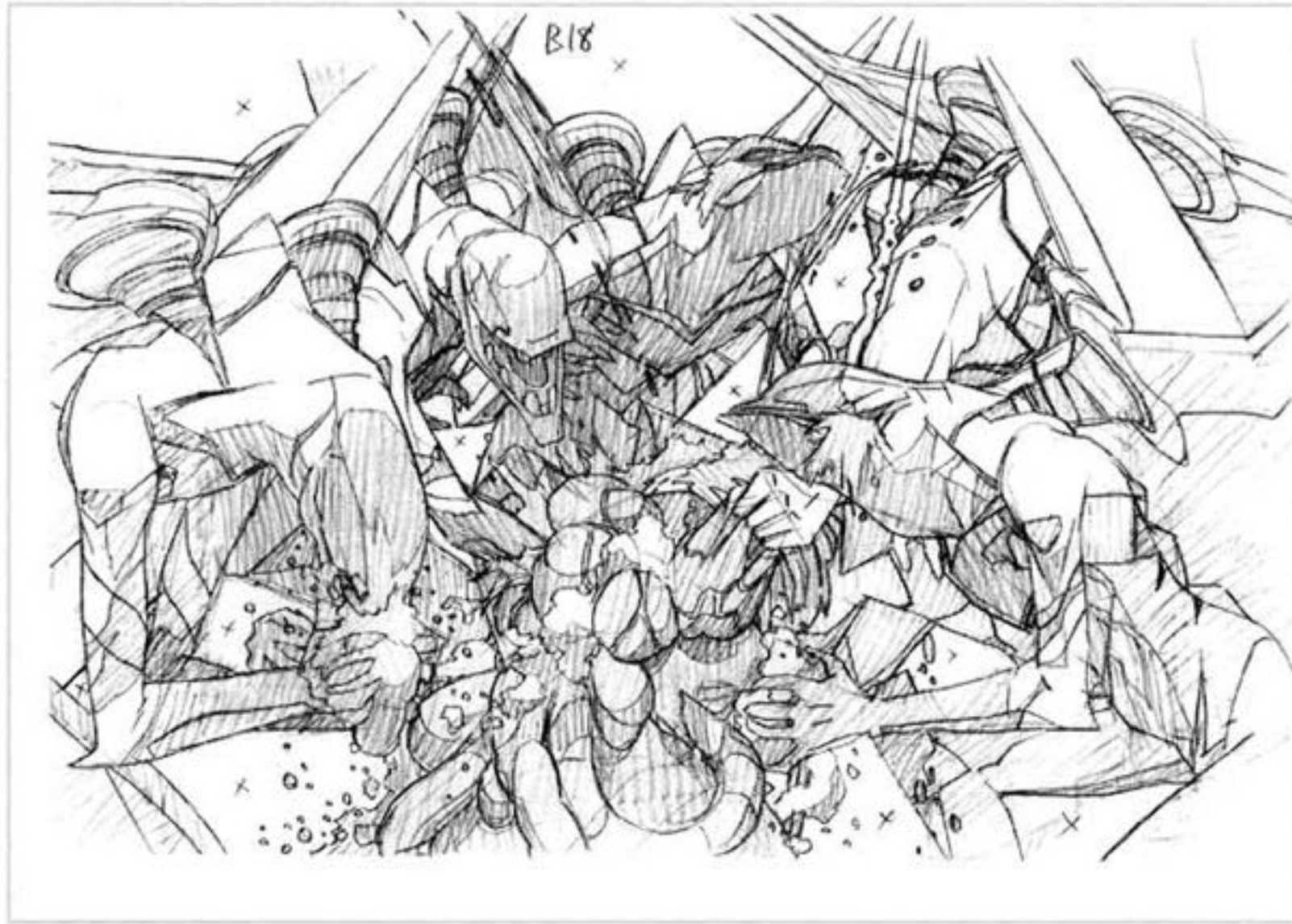

#25-C555





D0 (21(千)木竹)



C1 (10(千)木竹)

木竹

木竹



D2



C2

木竹

木竹

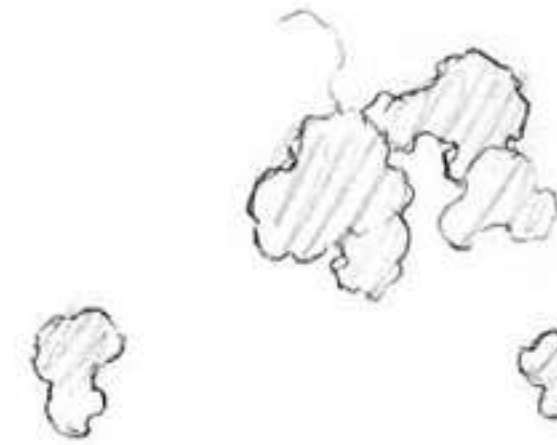

D3



C3

木竹

湯気

木竹



D4

木竹





BCD		
1	X 5	2
	6	4
	7	6
2	8	8
	9	10
	10	12
3	11	14
	12	16
	13	18
4	14	20
	15	22
	16	24
5	17	26
	18	28
	19	30
6	20	32
	21	34
	22	36
7	23	38
	24	40
	25	42
8	26	44
	27	46
	28	48
9	29	50
	30	52
	31	54
10	32	56
	33	58
	34	60
11	35	62
	36	64
	37	66
12	38	68
	39	70
	40	72
13	41	74
	42	76
	43	78
14	44	80
	45	82
	46	84

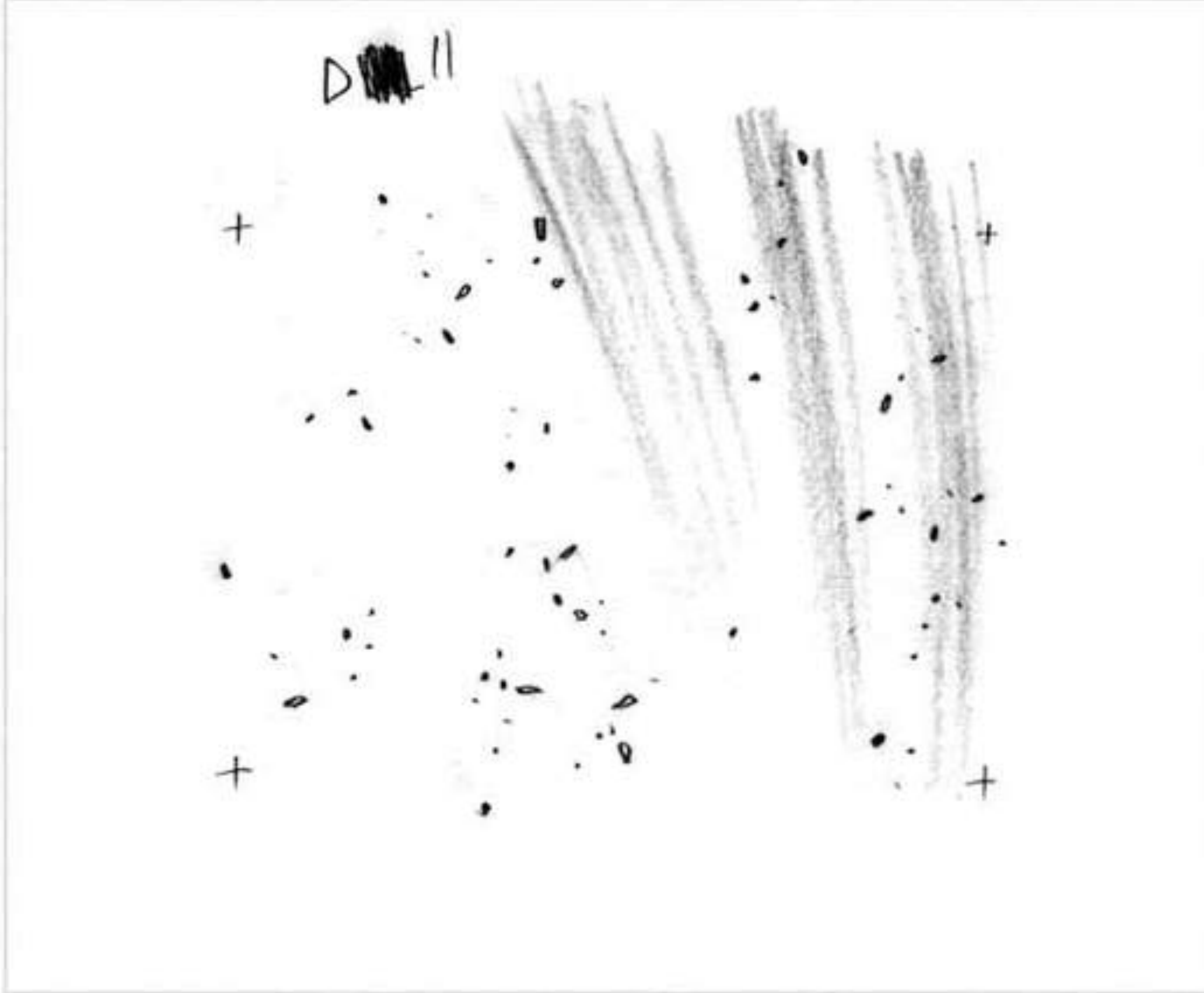
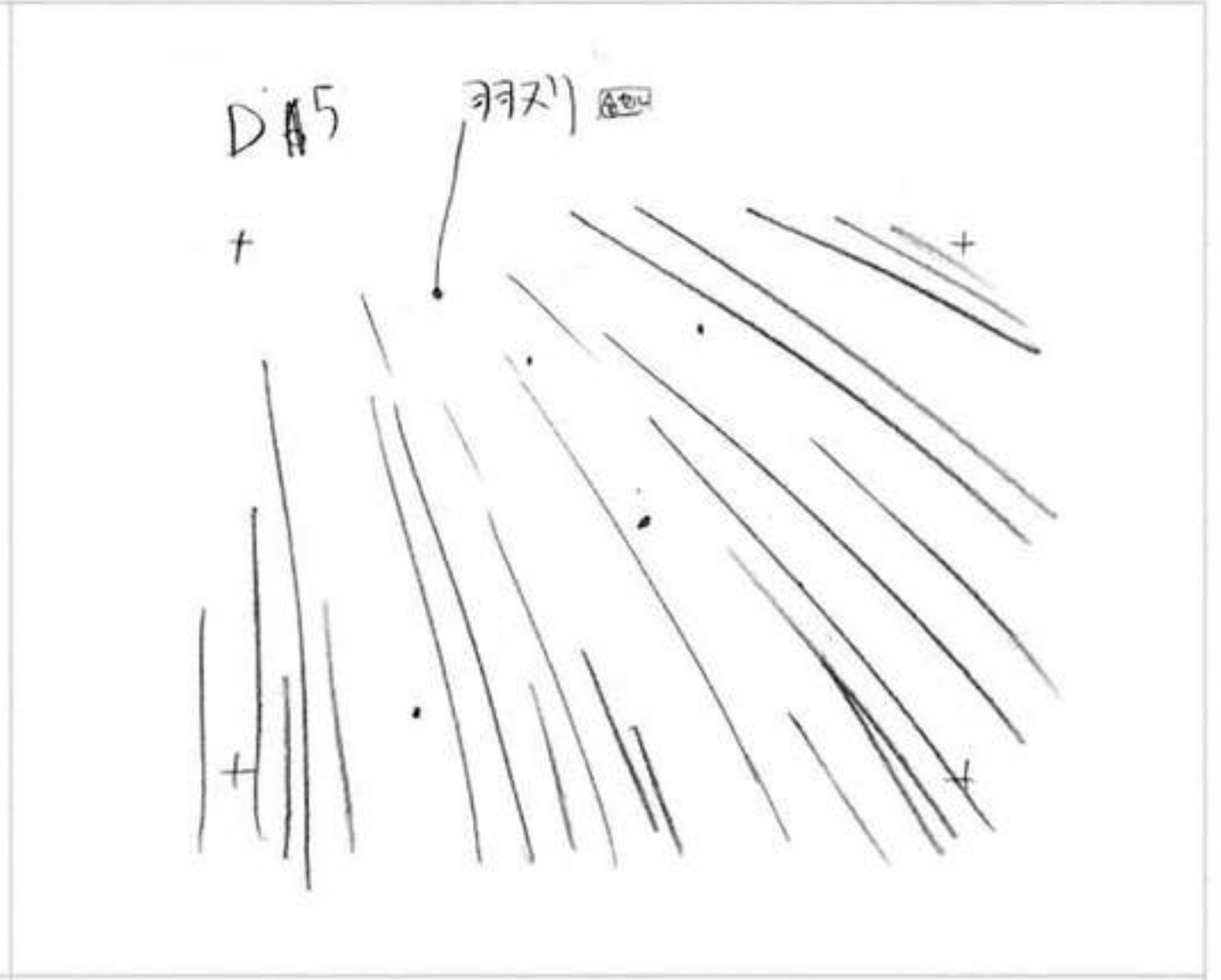
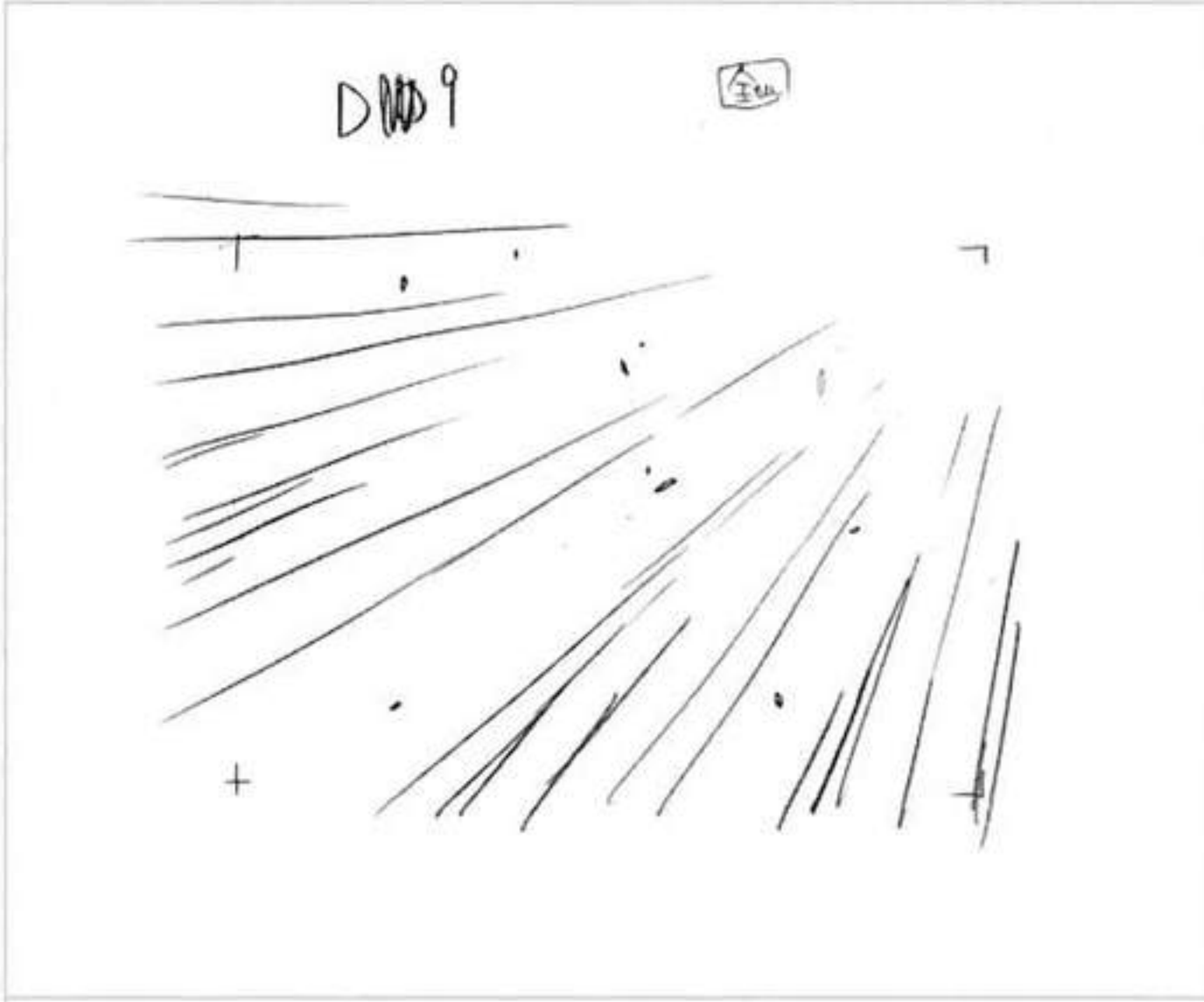

15	10	86
	11	88
	12	90
16	13	92
	14	94
	15	96
17	16	98
	17	100
	18	102
18	19	104
	20	

#25-C555  
タイムシート

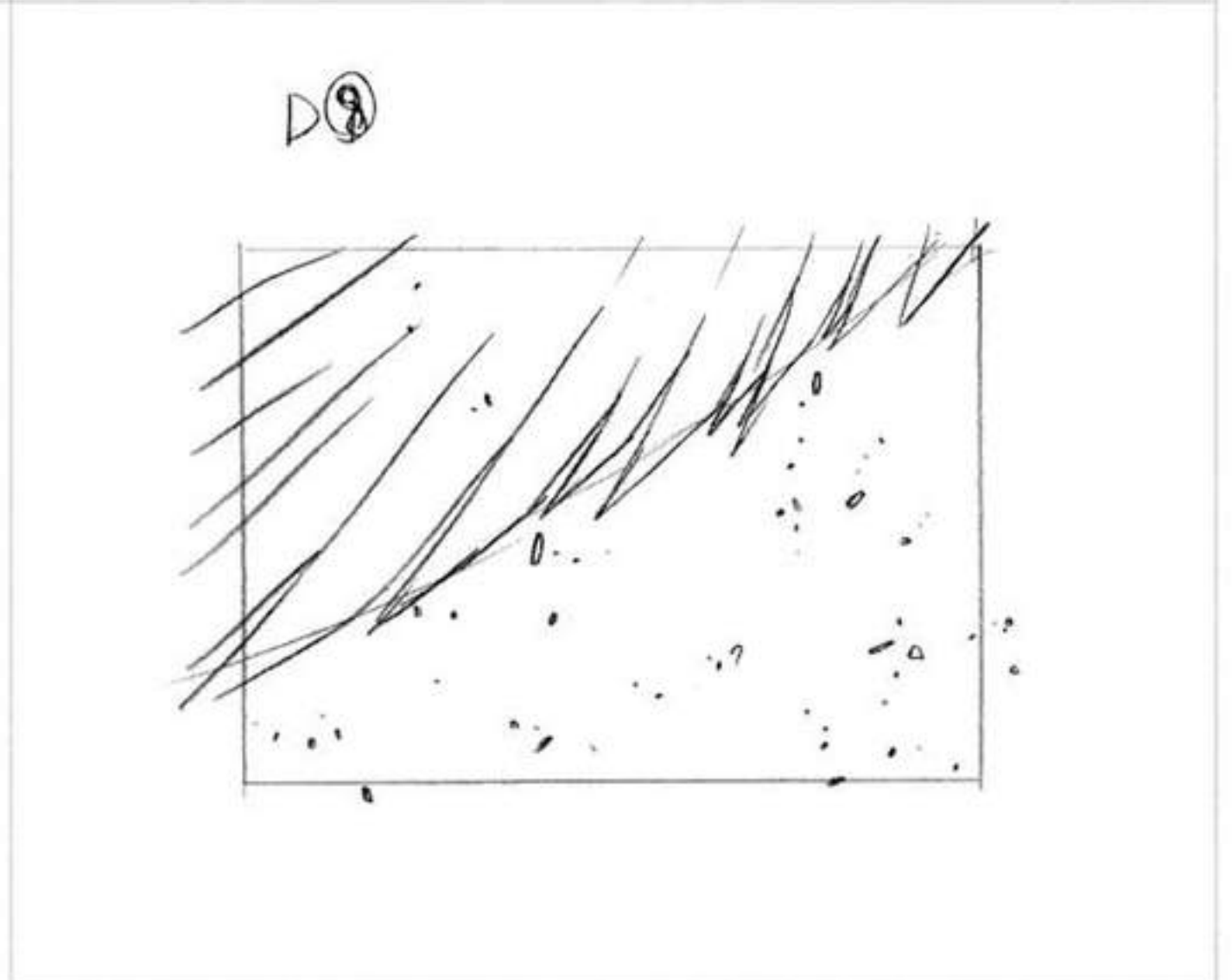







2 / 13

①



2 / 13

②



2 / 13

4th  
修正

③ 修正





棘 1157. 4-11. A Dex.



修正原画



修正原画



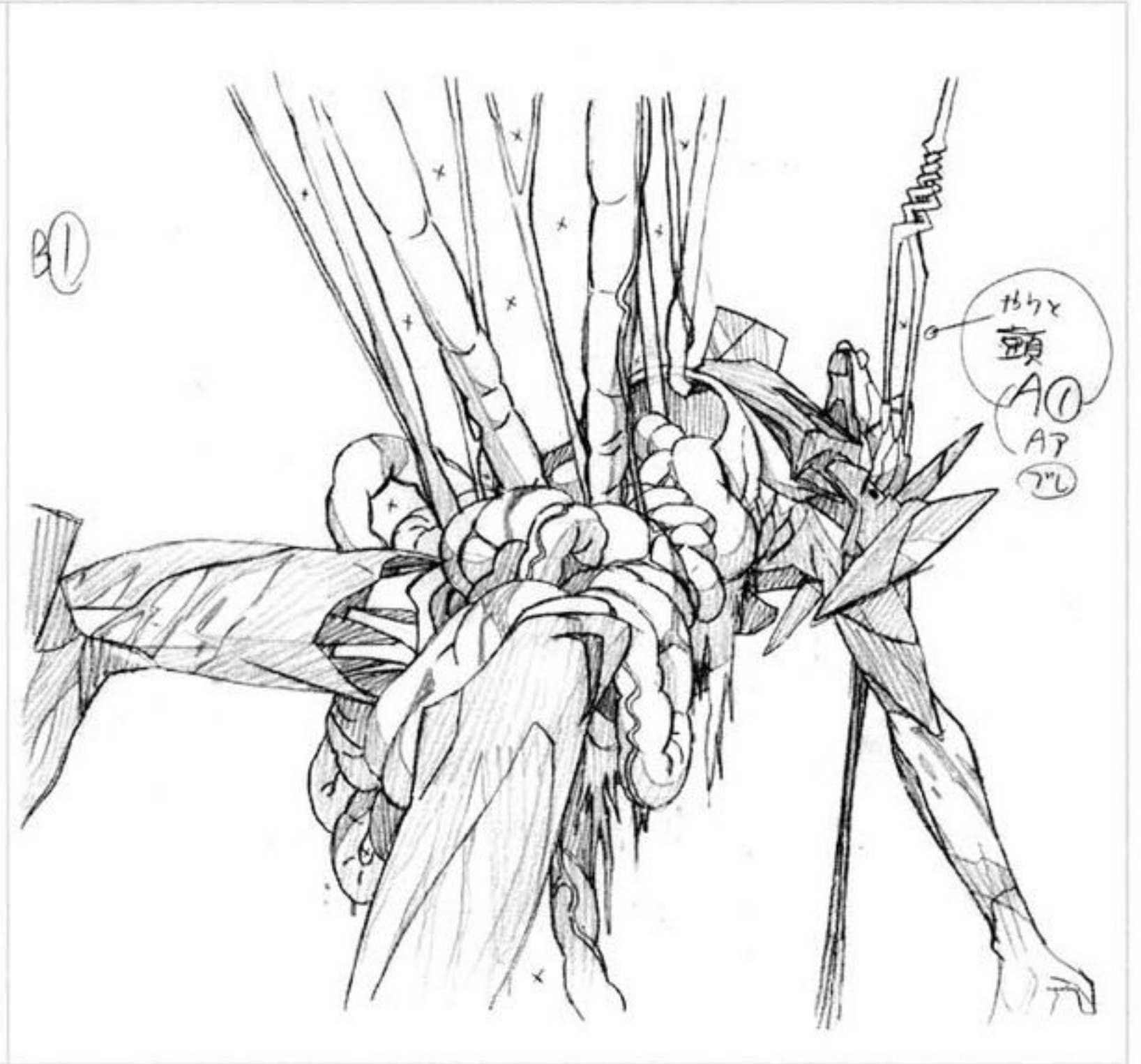
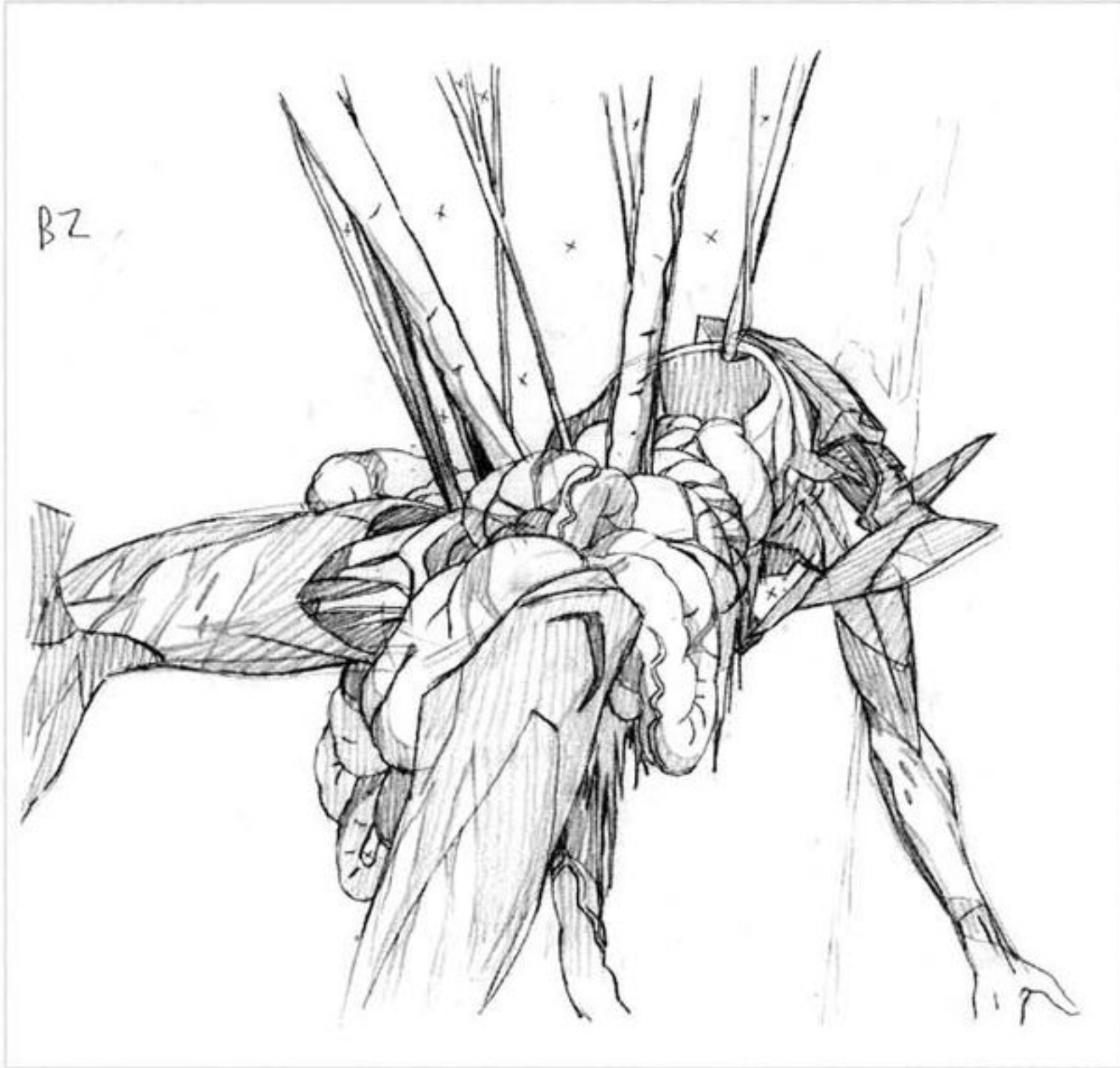

#25-C560



2  
1  
1  
1  
2

A vertical list of numbers: 2, 1, 1, 1, 2.



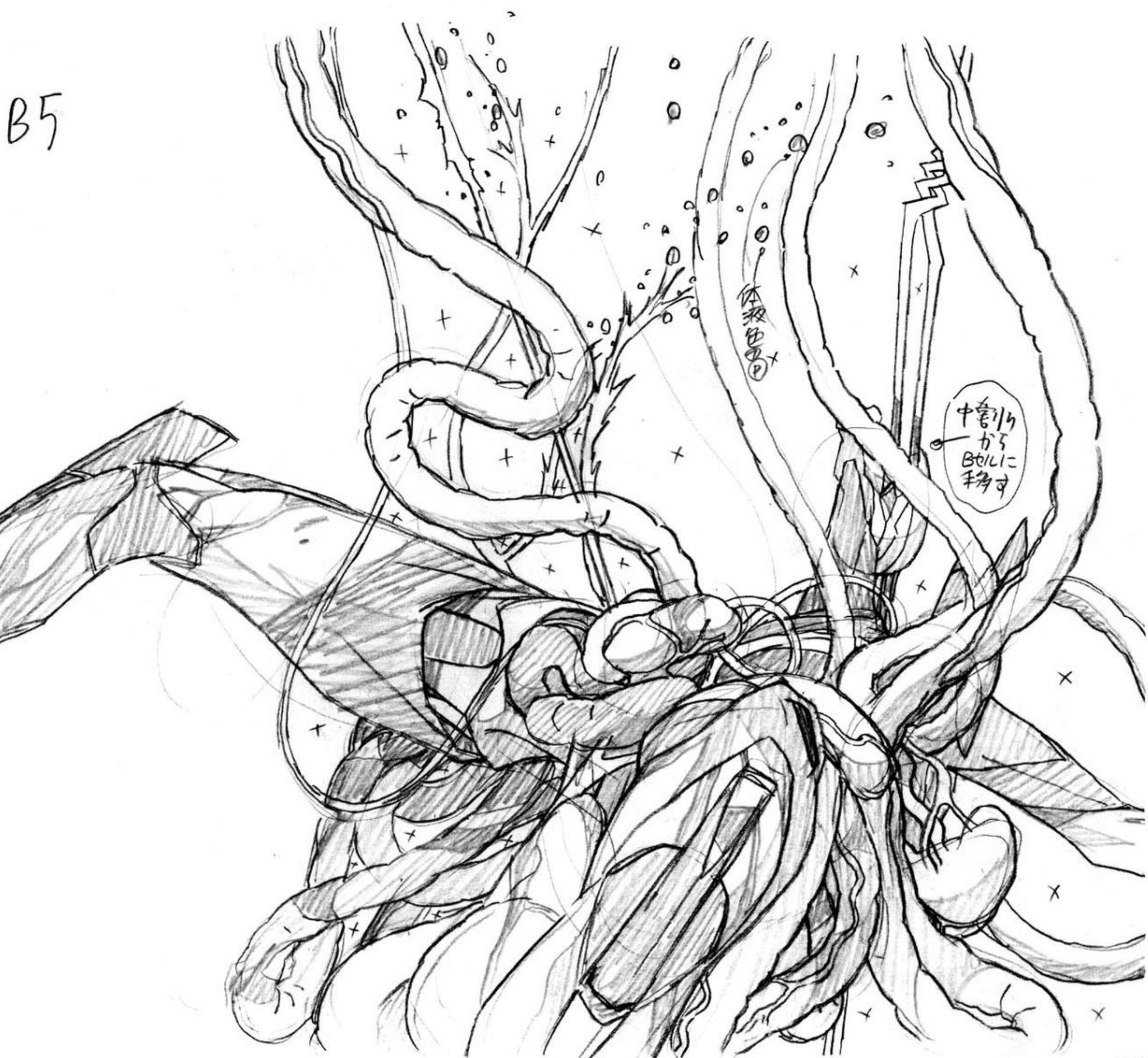
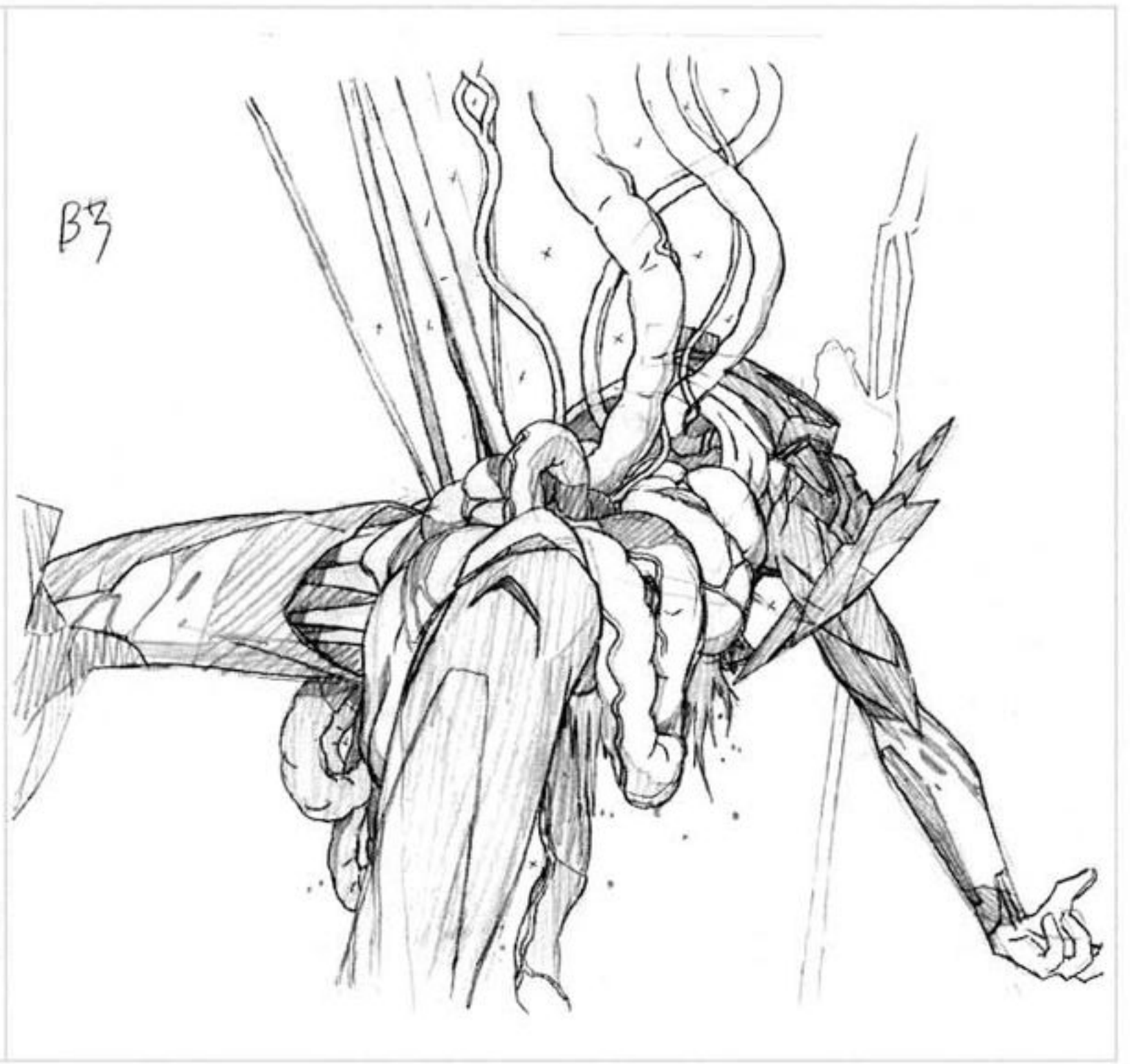
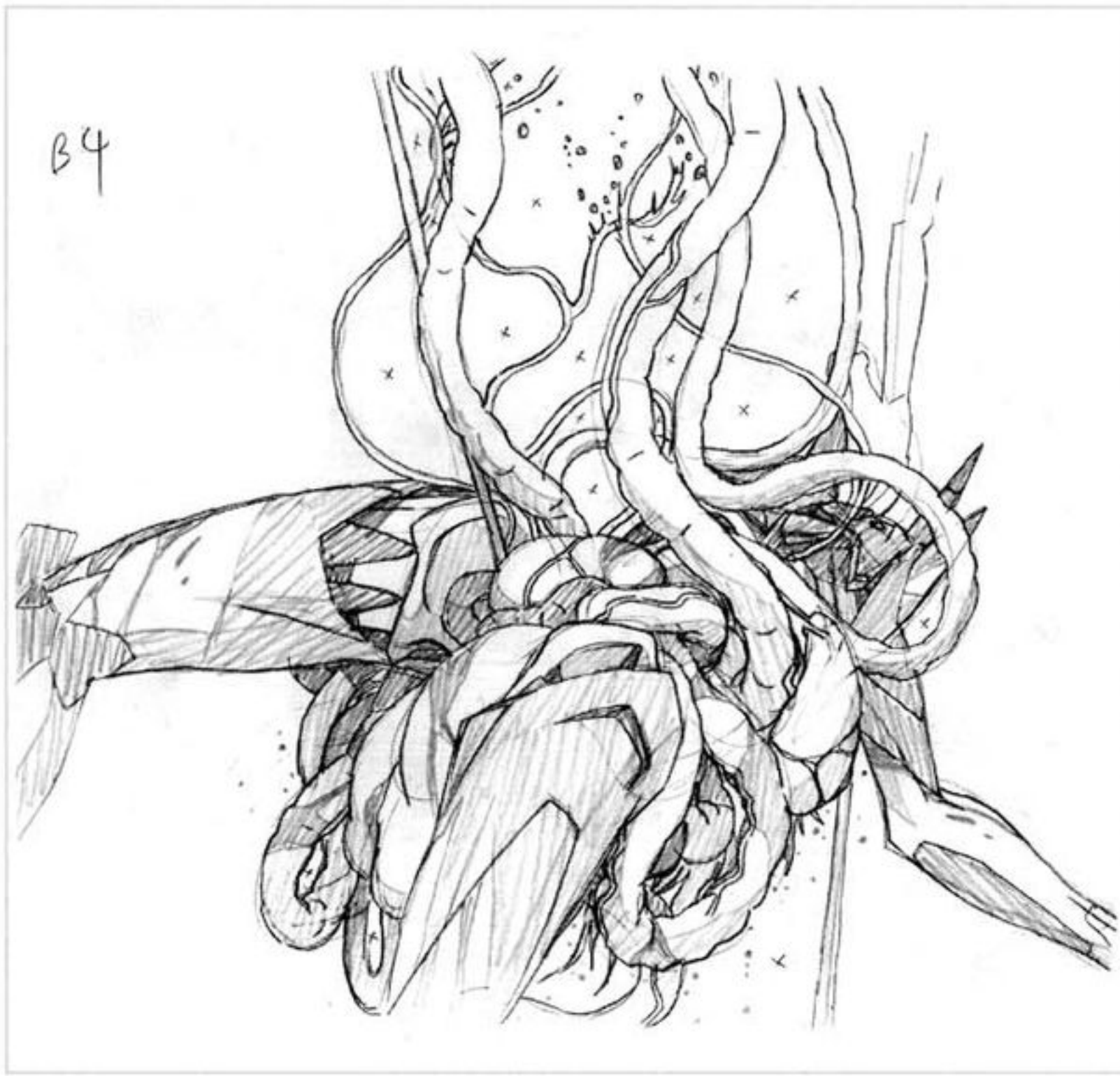



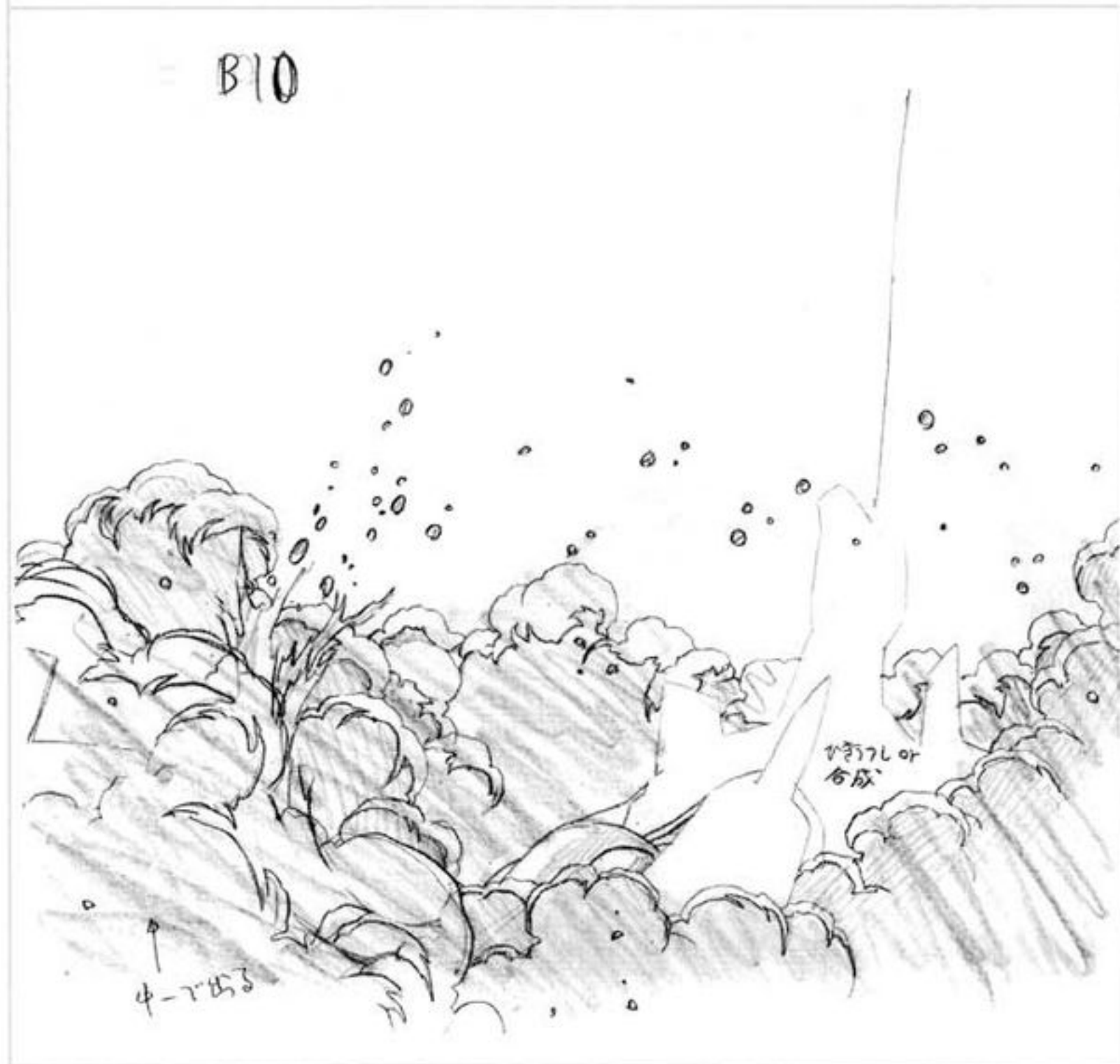

AB	
00	2
ア'	4
01	6
	8
ア'	10
01	12
	14
ア'	16
02	18
アア	20
02	22
ア1	24
0ア	26
アア	28
01	30

ア1	32
0ア	34
ア2'	36
01	38
ア2'	40
0ア	42
ア2'	44
01	46
ア2'	48
03	50
ア-	52
04	54
ア-	56
X-	58
	60

5	62
-	64
6	66
-	68
-	70
7	72
X7	74
-	76
-	78
8	80
-	82
9	84
-	86
-	88
10	90

#25-C560  
タイムシート





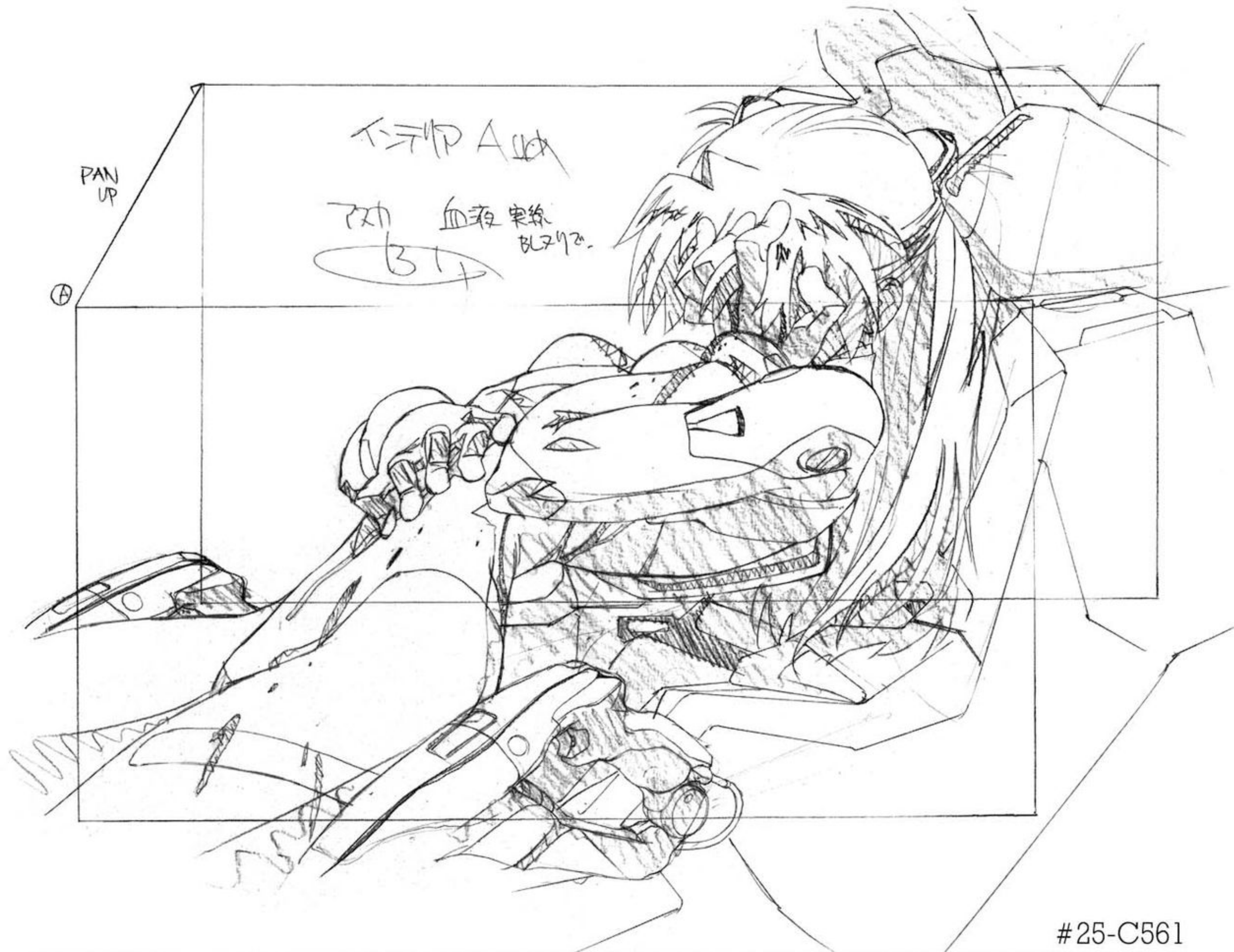

#25-C561



修正原画



修正原画

Handwritten notes and scribbles in the top left corner.



Handwritten circled note '机' (Machine) with a line pointing to the character's head.

Handwritten circled note 'B3' with '4' and '同+L7L' written below it.

Handwritten note 'Aenka' near the middle sketch.

Handwritten notes and scribbles in the bottom right corner.

修正原画



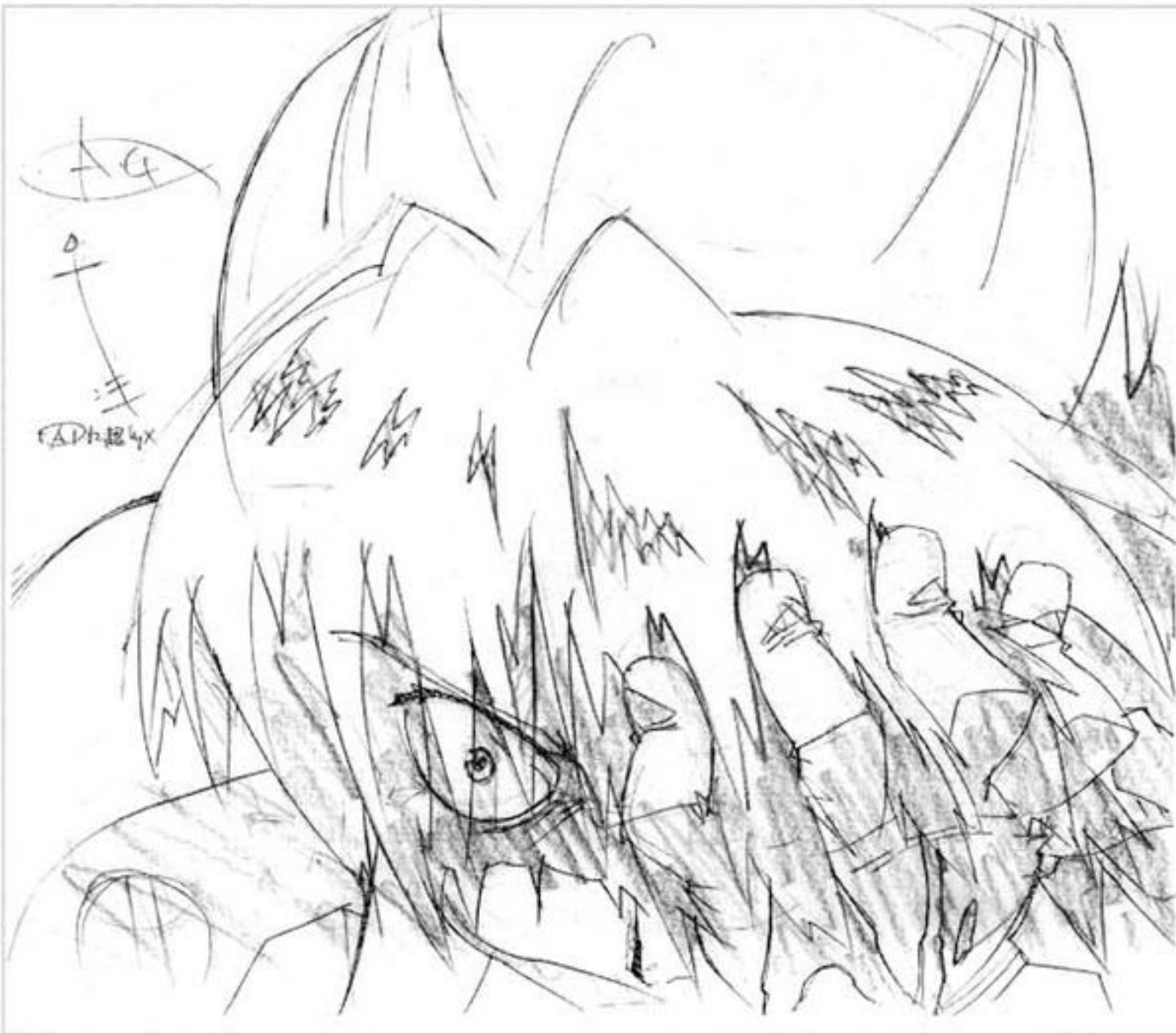

修正原画

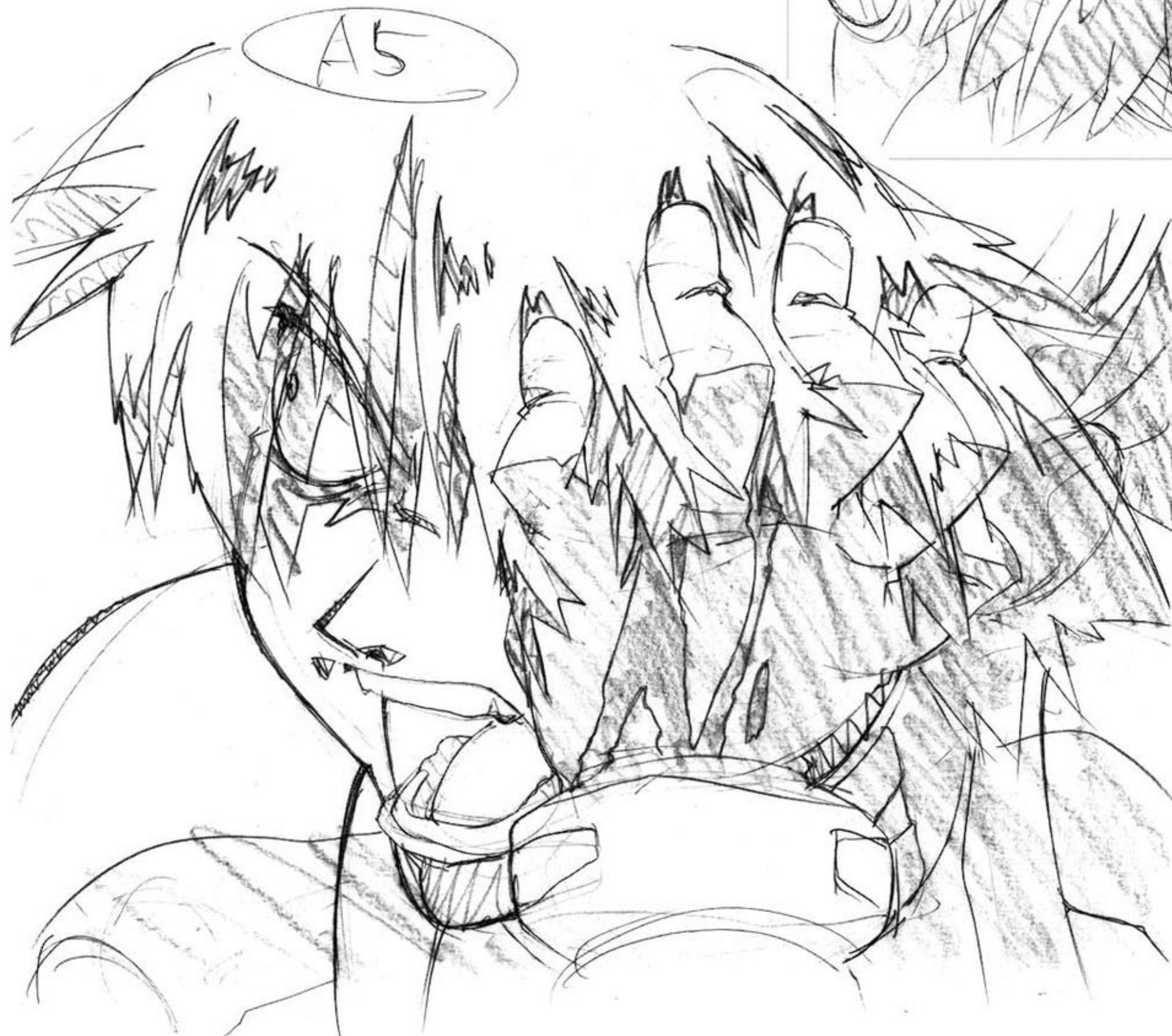
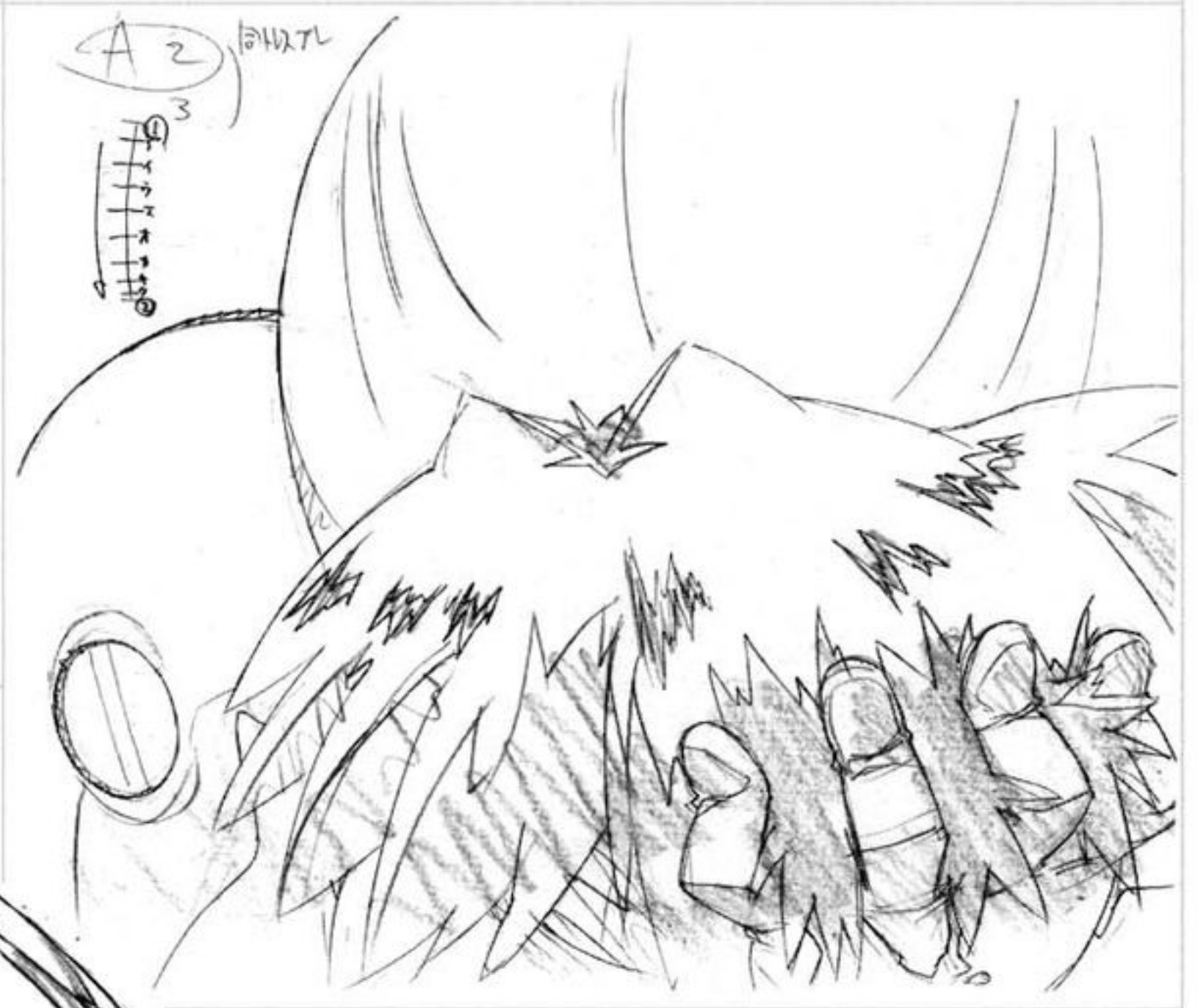
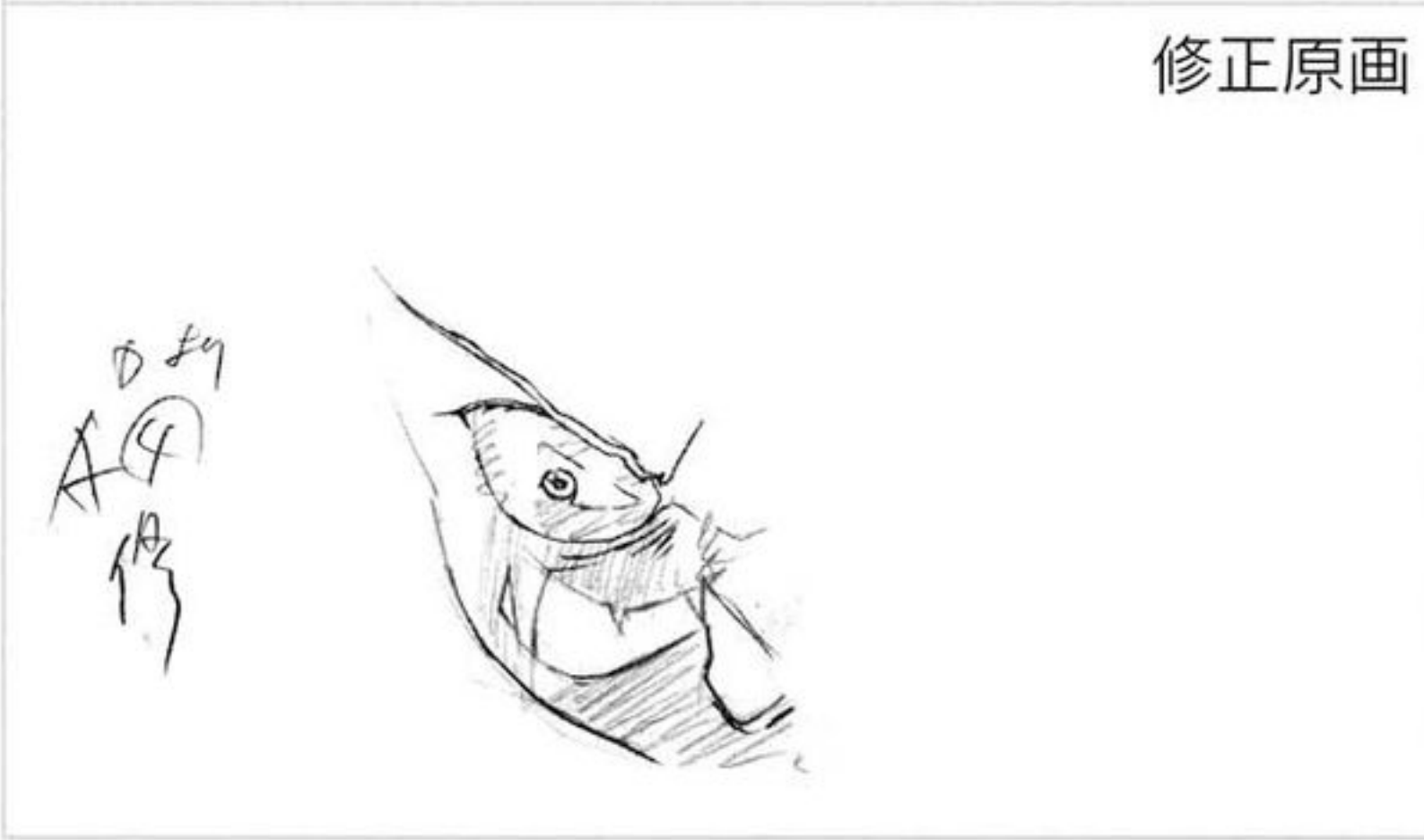

#25-C562



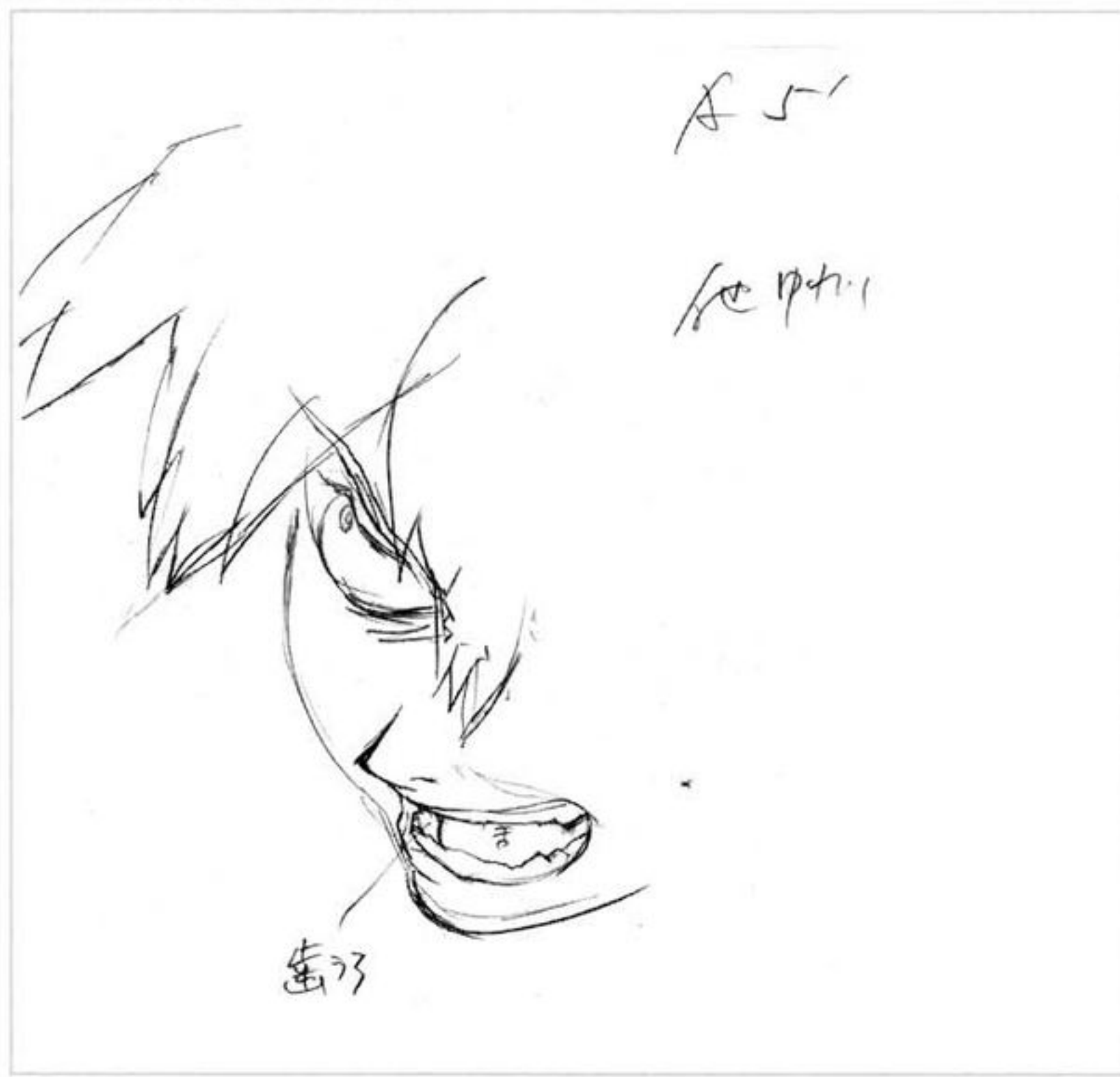

A(6)

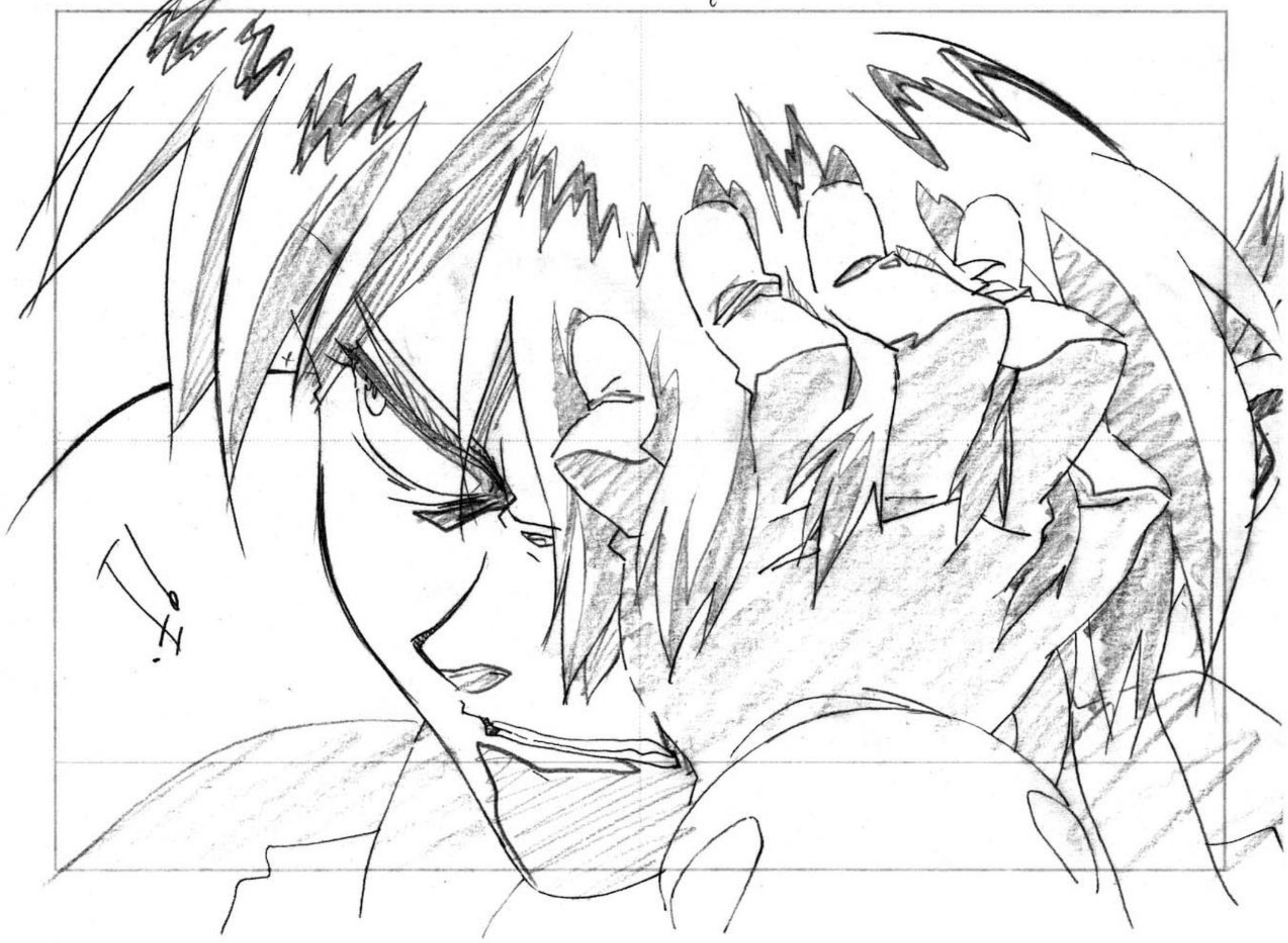



A		
①		2
ア		4
①		6
イ		8
ア		10
ウ		12
イ		14
エ		16
ウ		18
オ		20
ウ		22
エ		24
オ		26
キ		28
カ		30
ク		32
キ		34
②		36
キ		38
②		40
ク		42
②		44
②		46
ク		48
②		50
、		52
①		54
ア		56
①		58
ウ		60
イ		62
オ		64
カ		66
キ		68
ク		70
		72

ク		74
キ		76
②		78
ク		80
②		82
③		84
③		86
②		88
キ		90
②		92
ク		94
②		96
②		98
、		100
、		102
④		104
⑤		106
⑤		108
⑥		110
コ		112
ケ		114
サ		116
コ		118
⑦		120
⑦		122
⑦		124



修正原画



修正原画

#25-C562  
タイムシート





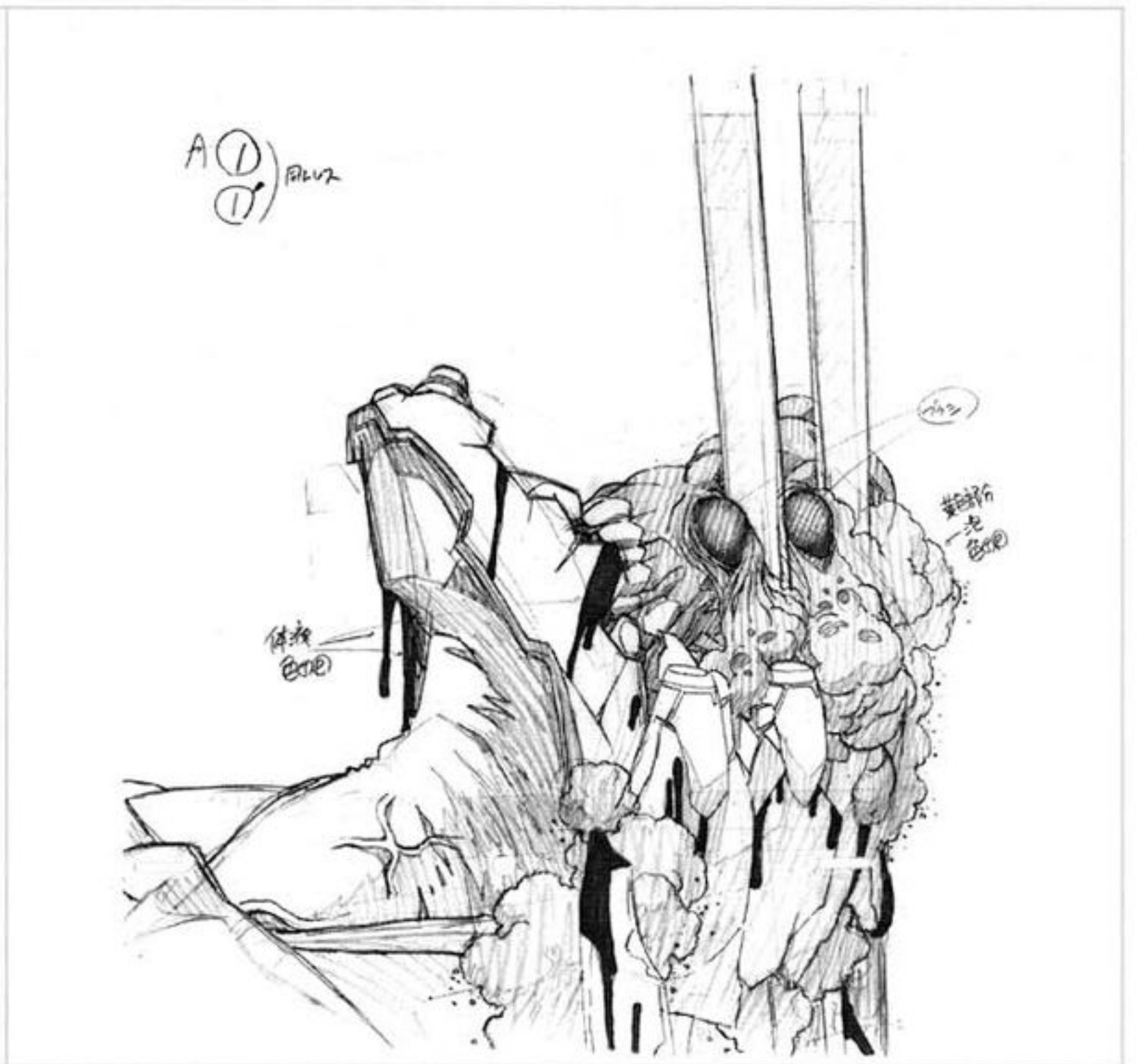
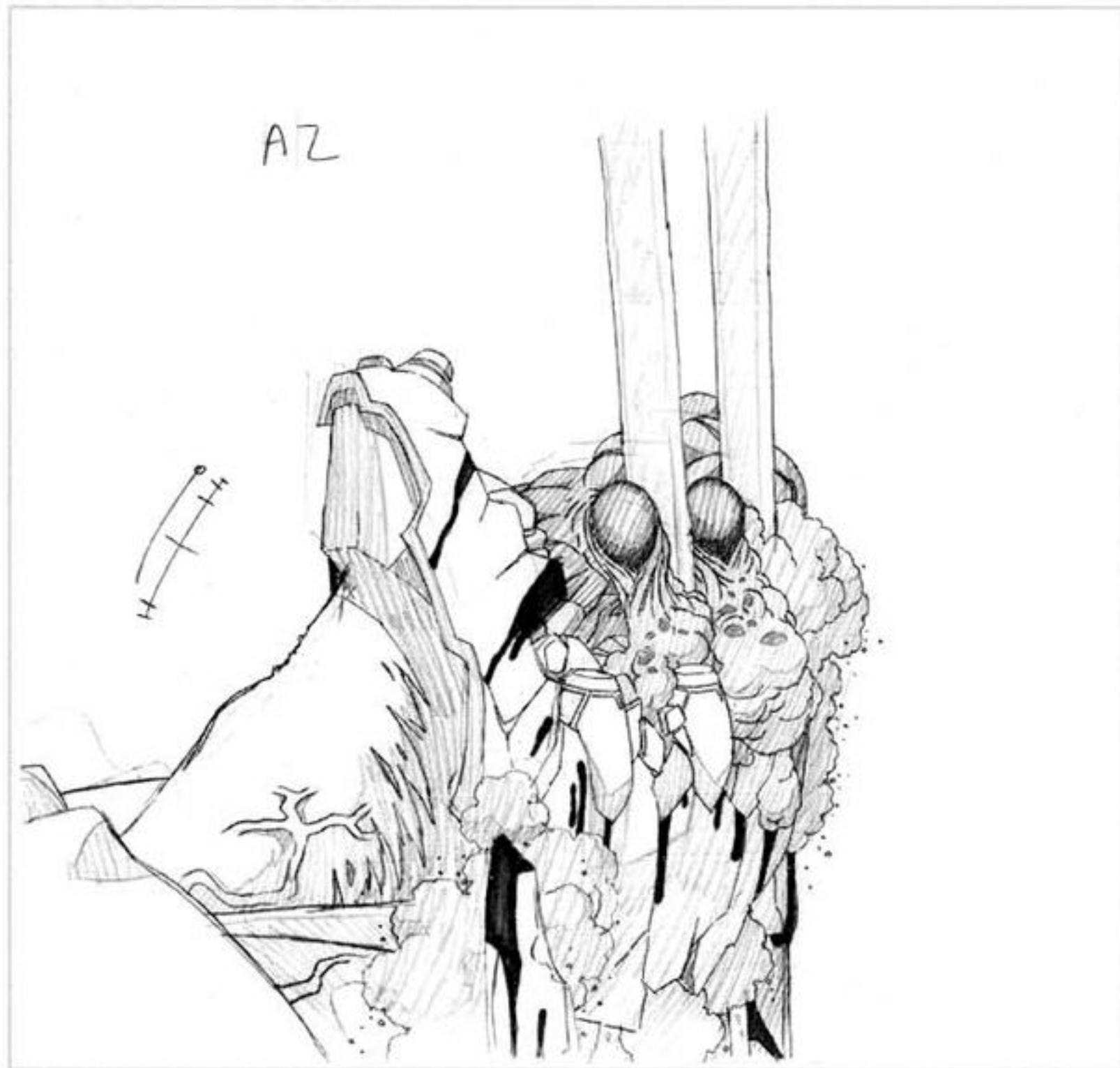

#25-C563





C1

C12 せうらうち



手と足に血痕  
BIZONの爪せう

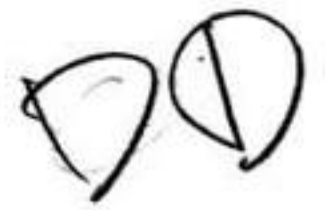

#25-C563

修正原画

修正原画

C1  
修



C1  
修



C10



せうらうち

血痕  
BIZONの爪  
D10  
せうらうち

C7



手と足に血痕  
BIZONの爪  
D7  
せうらうち



C-14

修正原画



C10

修正原画



修正原画

C24



C14



☆ C(2) 21 5754



C26

29 26



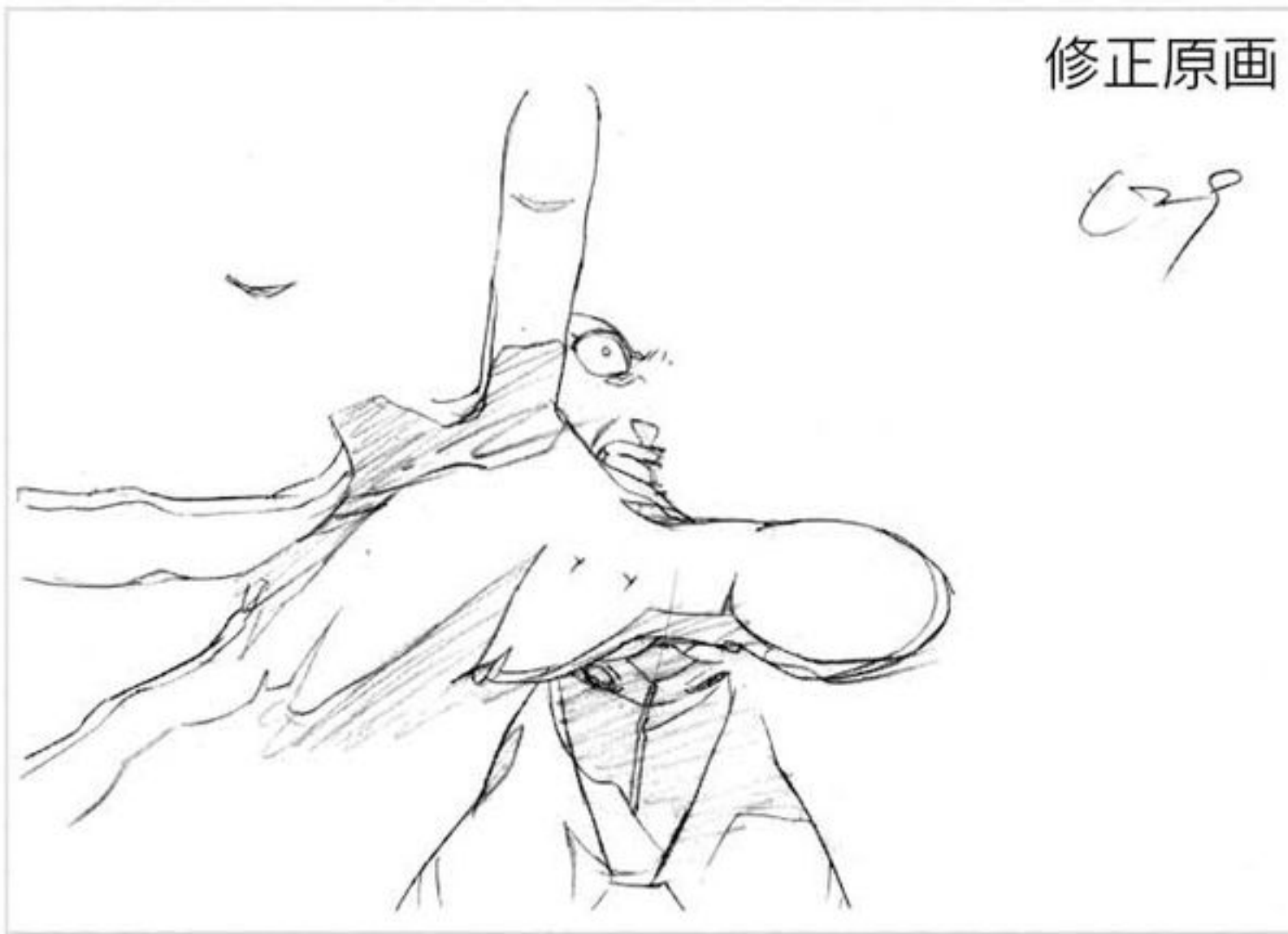

#25-C563 タイムシート

A	B	C	D	
X	0	0	0	2
	2	2		4
	0	0		6
	3	3		8
	2	2		10
	4	4		12
	3	3		14
	5	5		16
	4	4		18
	5	5		20
	4	4		22
	5	5		24
	6	6		26
	7	7		28
	8	8		30
	9	9		32
	10	10		34
	9	9		36
	11	11		38
	10	10		40
	12	12		42
	11	11		44
X	13	X		46
	12			48
	14			

13	50
14	52
15	54
16	56
15	58
17	60
16	62
18	64
17	66
19	68
18	70
20	72
19	74
21	76
18	78
19	80
20	82
20	84
22	86
21	88
23	90
22	92
24	94
23	96

25	98
24	100
23	102
25	104
24	106
26	108
25	110
27	112
26	114
28	116
27	118
29	120
28	122
30	124
29	126
31	128
30	130
32	132
31	134
33	136
32	138
34	140
33	142
34	144





#25-C569

227  
B 1





修正原画



修正

修正原画



修正

B5



6  
2  
3  
4

(B5)





修正原画







#25-C571





#25-C577

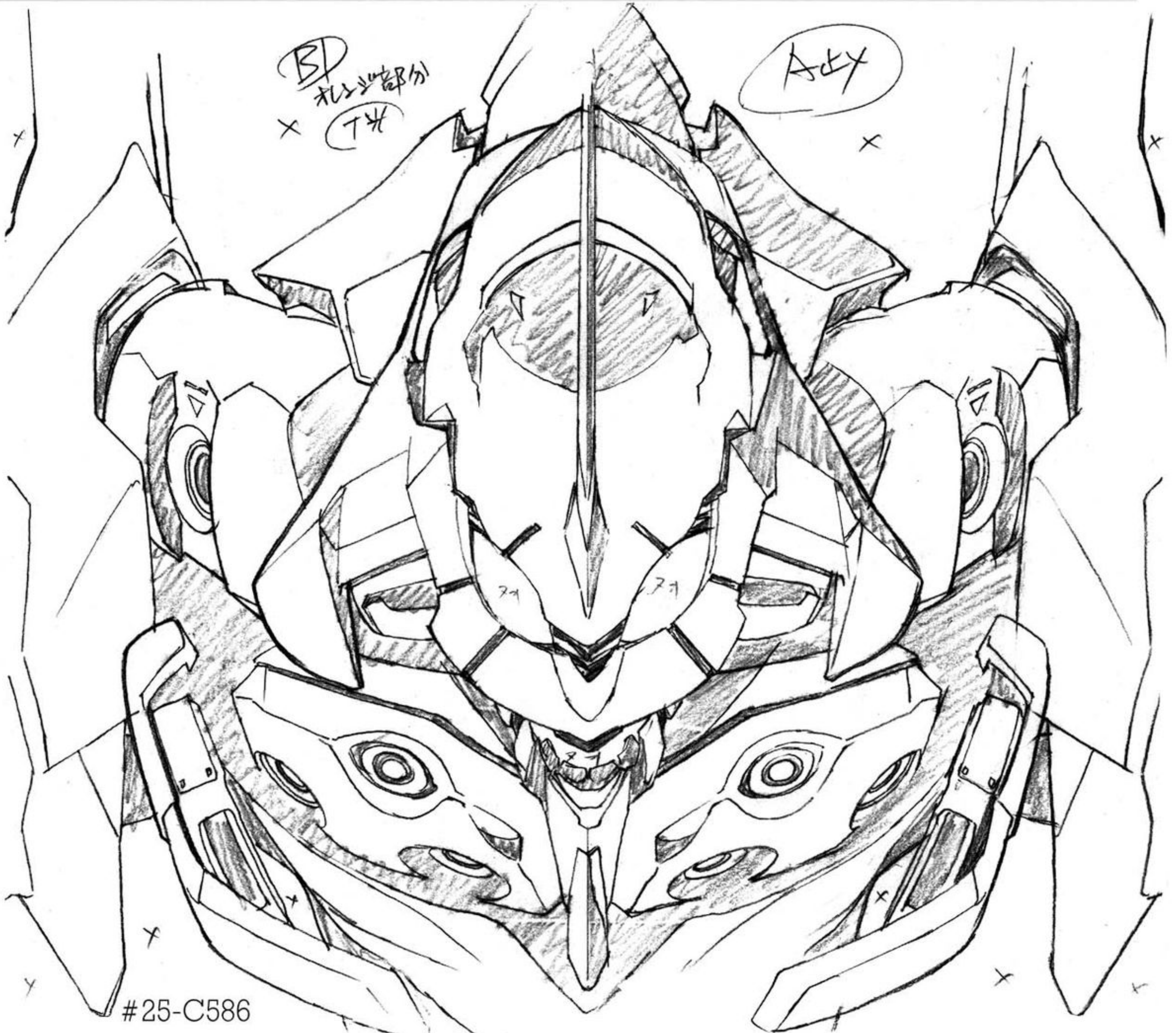

#25-C586





#25-C587

修正原画



片



修正原画



髪型  
修正  
After  
Film  
全



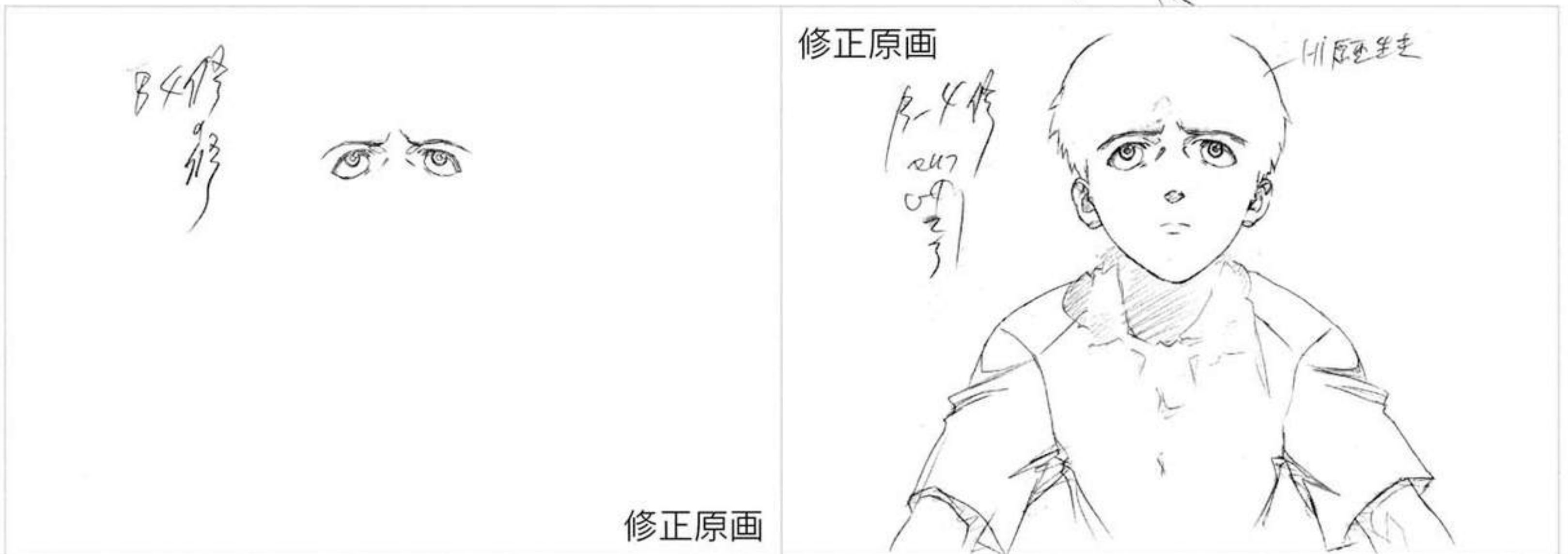
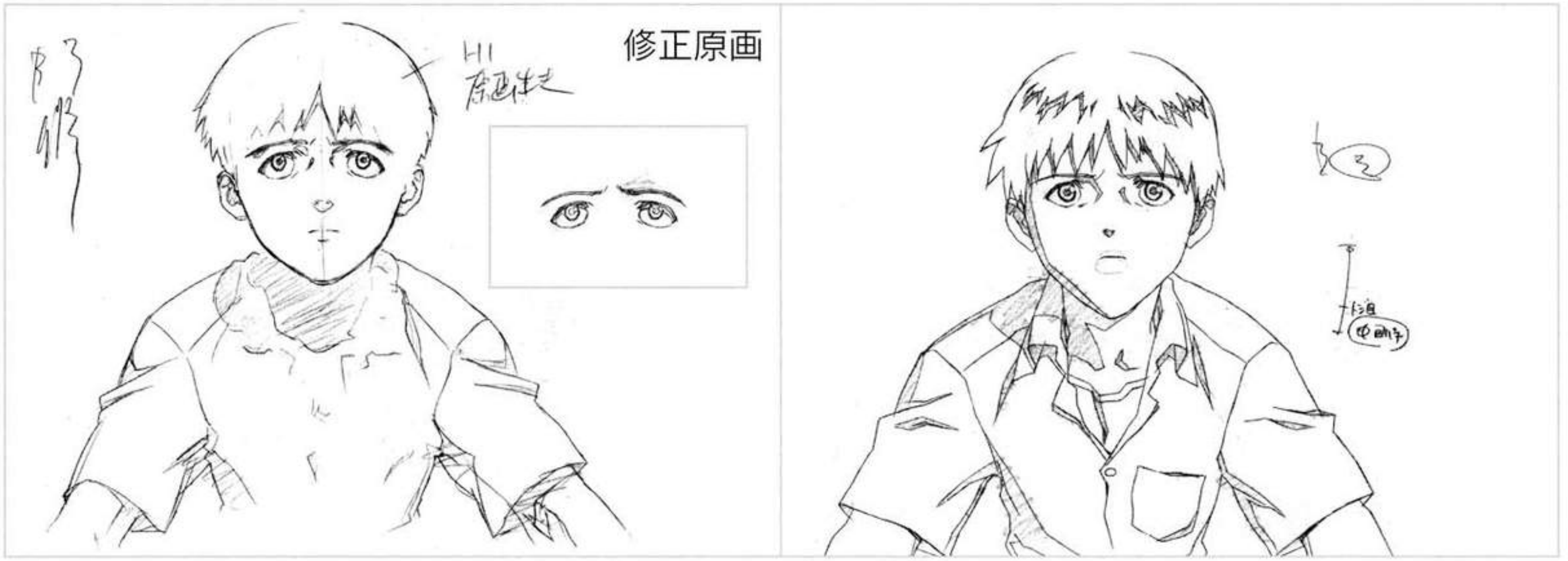



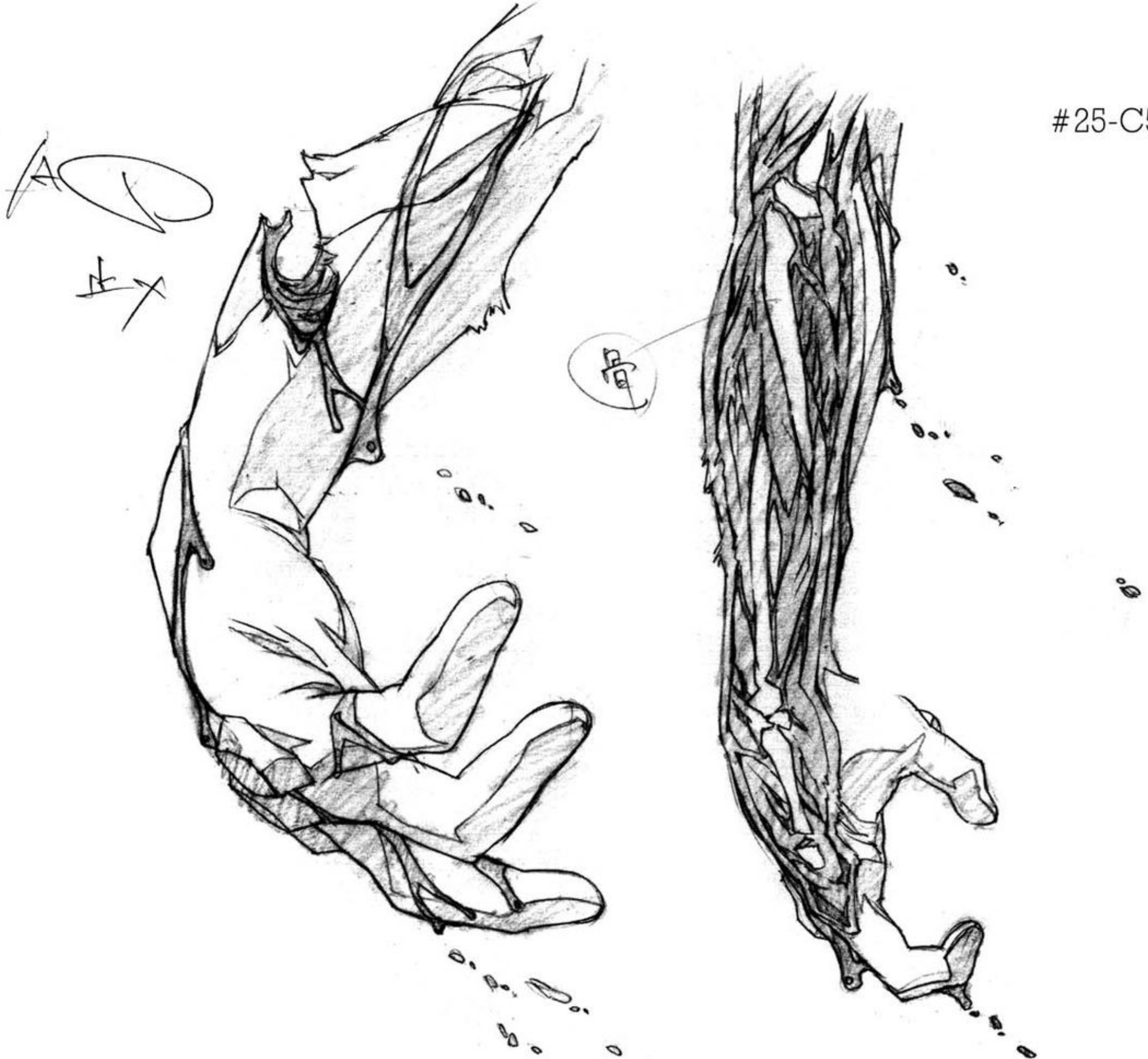





#25-C593

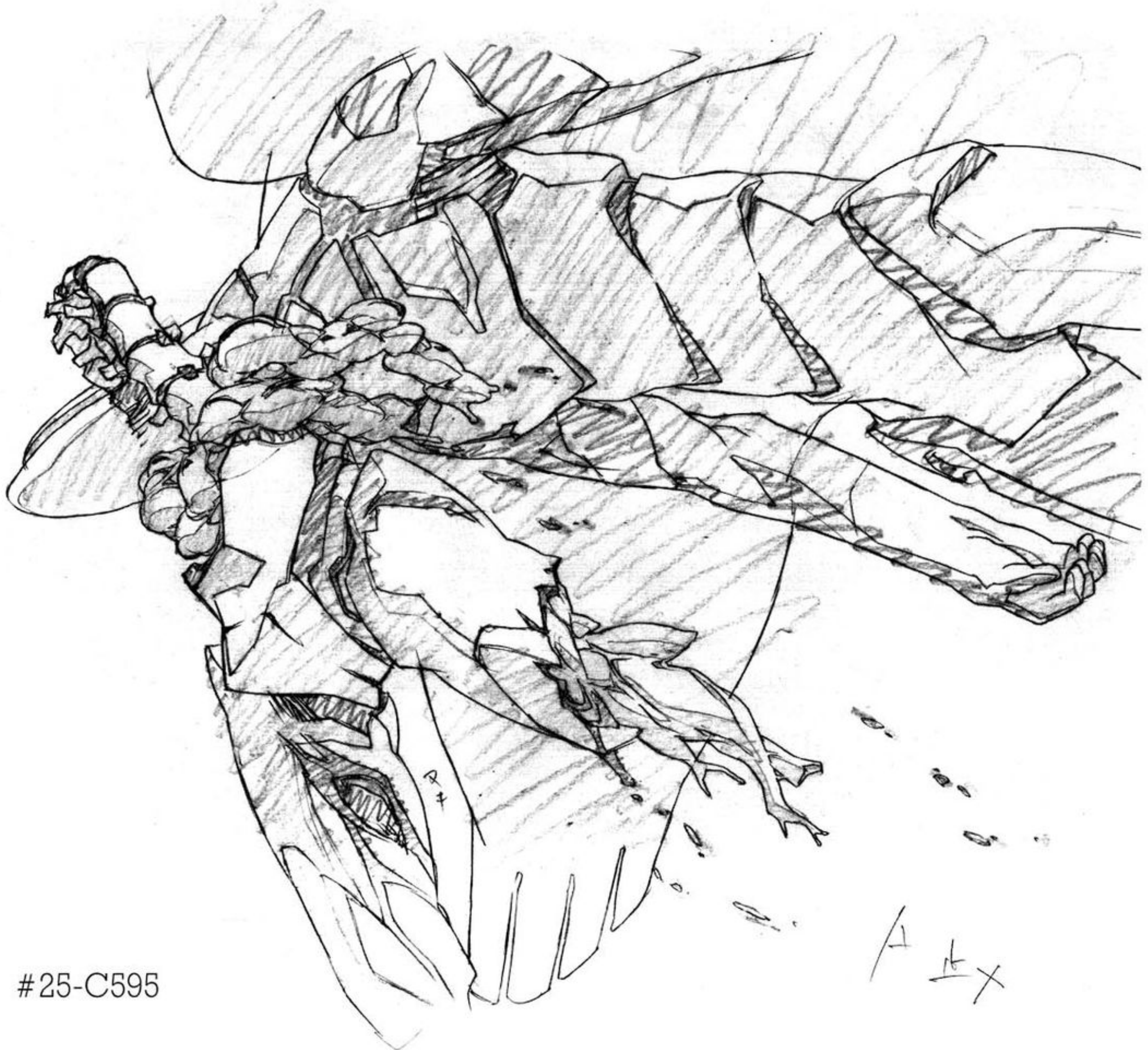

#25-C595





#25-C594





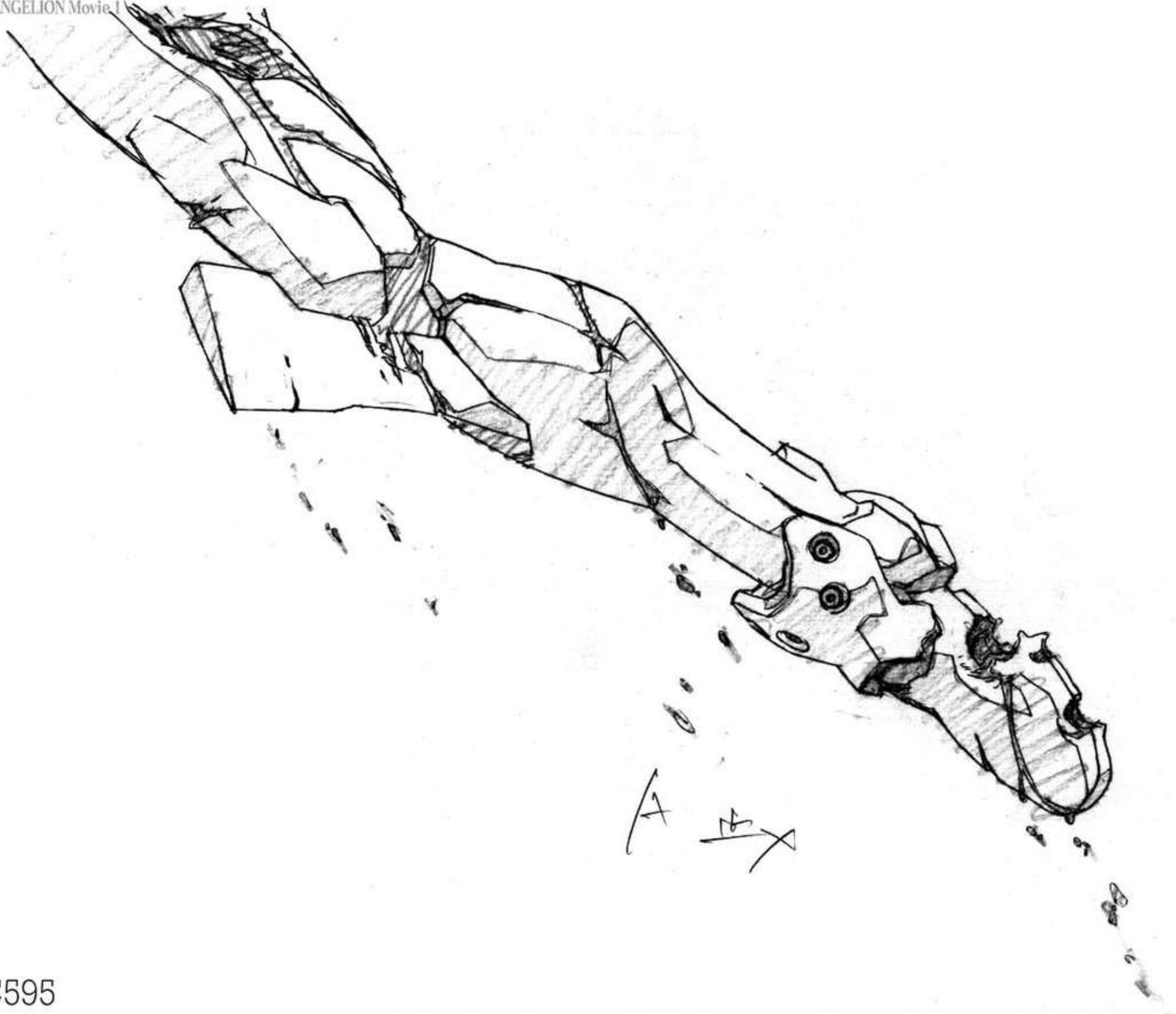

#25-C595

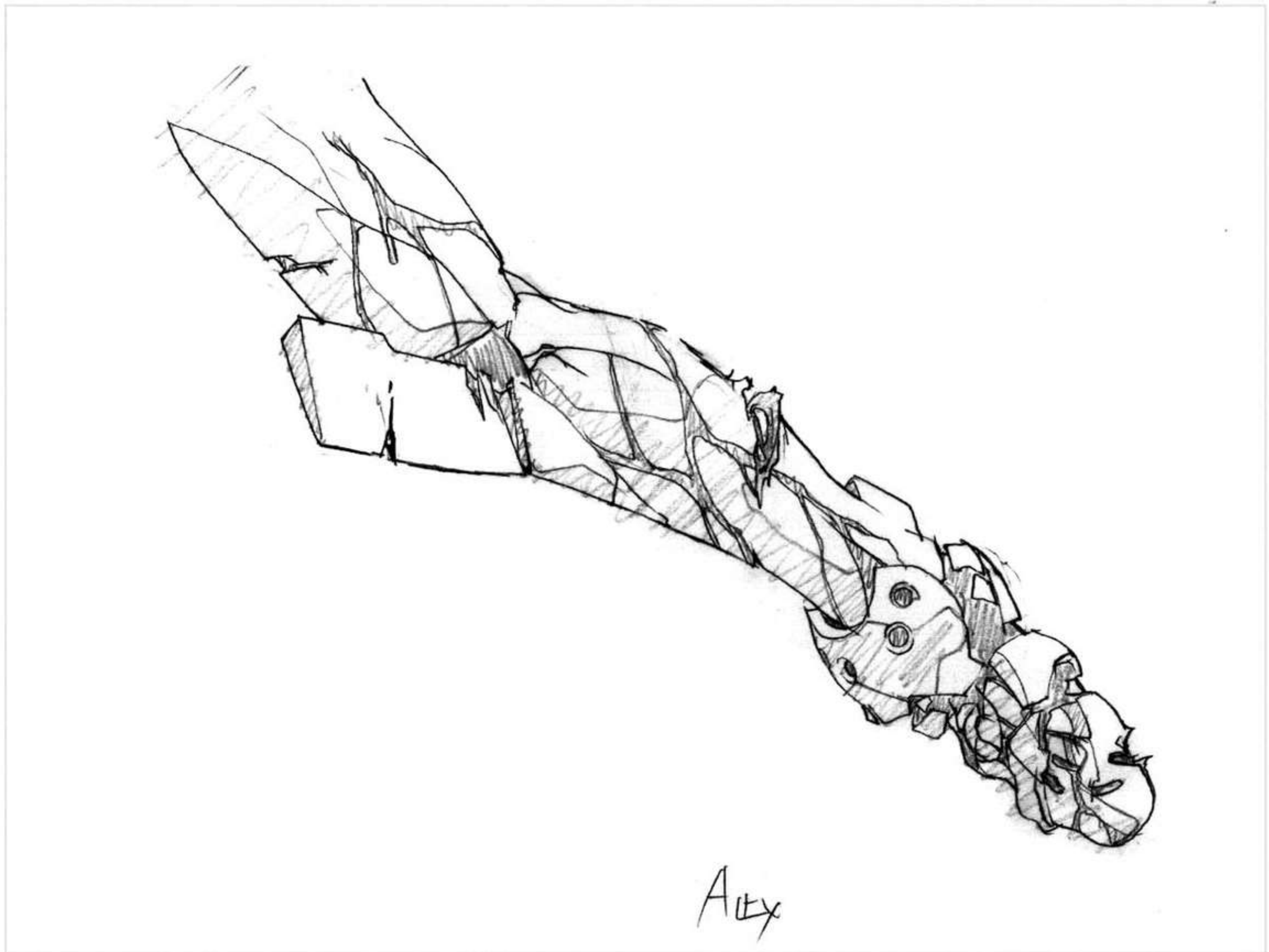





A 1



A 2

7/11/11



A 3

7/11/11











A		
①		
/		74
/		
/		76
/		
/		78
/		
/		80
②		
/		82
/		
/		84
/		
③		
/		88
/		
④		
/		90
/		
/		92
/		
⑤		
/		94
/		
/		96

タイムシート

/			98
⑥			
/			100
/			
/			102
/			
/			104
/			
/			106
/			
⑦			108
/			
/			110
/			
/			112
/			
/			114
/			
/			116
/			
/			118
/			
⑧			120
/			
/			122



A ⑧  
描き直し

A ⑧  
描き直し



A ⑧  
END

マ

マ





# Groundwork of EVANGELION The Movie 1

新世紀エヴァンゲリオン劇場版原画集 上巻

## ■ DEATH

作画監督

摩砂雪  
貞本 義行  
庵野 秀明

原画

平松 禎史 野田 武広 摩砂雪 増尾 昭一 中山 勝一  
今石 洋之 貞本 義行 庵野 秀明

## ■ Air

# 25 キャラクター作画監督

黄瀬 和哉

# 25 メカニック作画監督

本田 雄

# 25 原画 (五十音順)

安藤 真裕 庵野 秀明 石井 明治 石田 敦子 磯 光雄  
伊藤 岳史 今石 洋之 今掛 勇 入江 健司 大倉 雅彦  
岡村 天斎 小倉 陳利 鴨川 浩 河口 俊夫 後藤 隆幸  
佐藤 雅将 篠原 健二 砂田 茂樹 関口 雅浩 竹内 敦志  
竹内 志保 丹澤 学 鍋田 香代子 野田 武広 野中 卓也  
平松 禎史 福岡 英典 古川 尚哉 本田 雄 前田 真宏  
増尾 昭一 摩砂雪 三浦 和也 村木 靖 守岡 英行  
森島 範子 谷津 美弥子 吉成 曜



**新世紀エヴァンゲリオン劇場版原画集 上巻 特典**





S. DEATH C. 385

TIME ( + )

PRODUCTION I.G



Yo consult 動きはモトのYoのラフのままOKです。スクリプトの修正とアスタの4コマのこの5コマは



S.DEATH C. 572

TIME ( + ) PRODUCTION I.G  
作画 指号 76-4=551

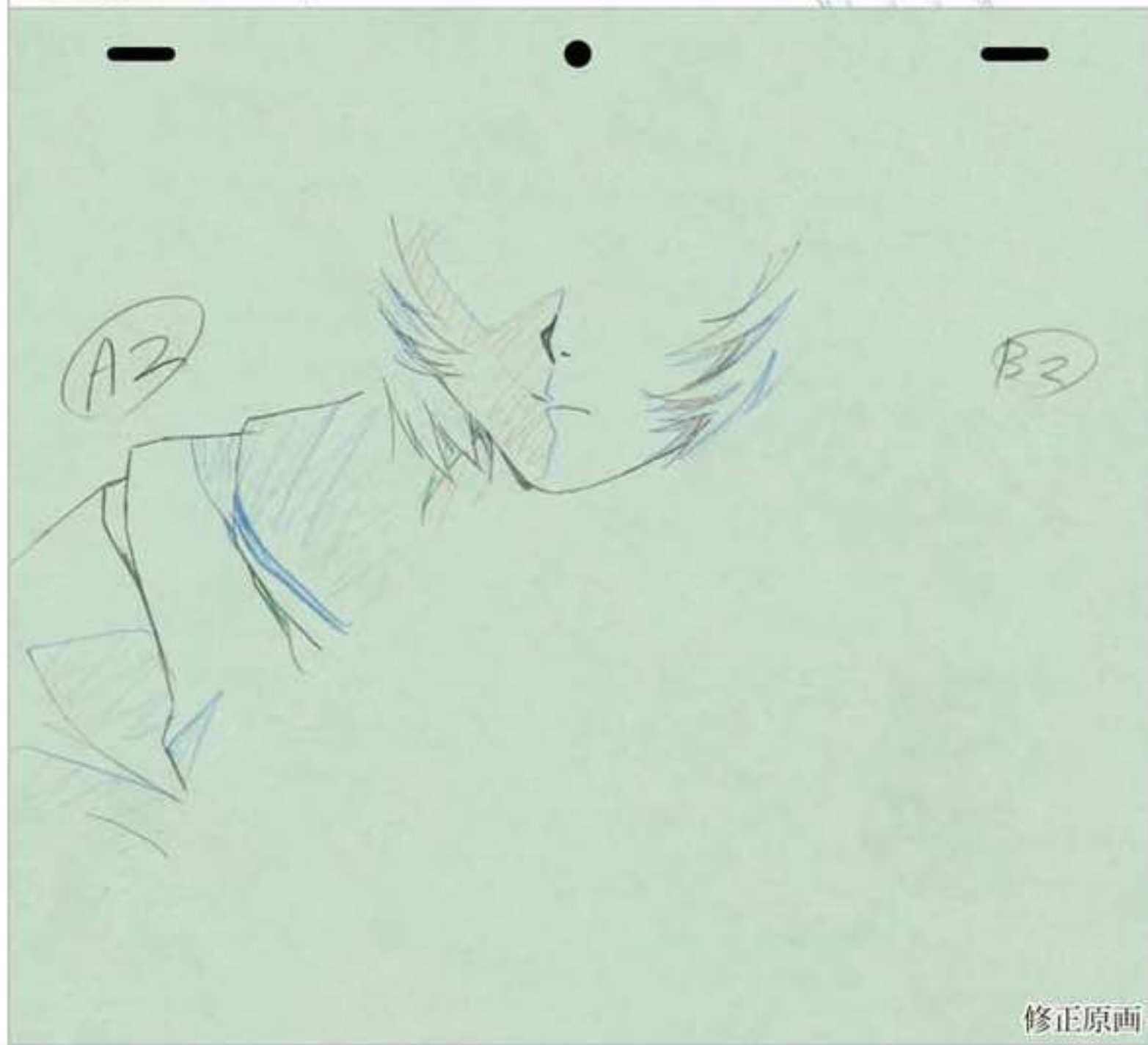
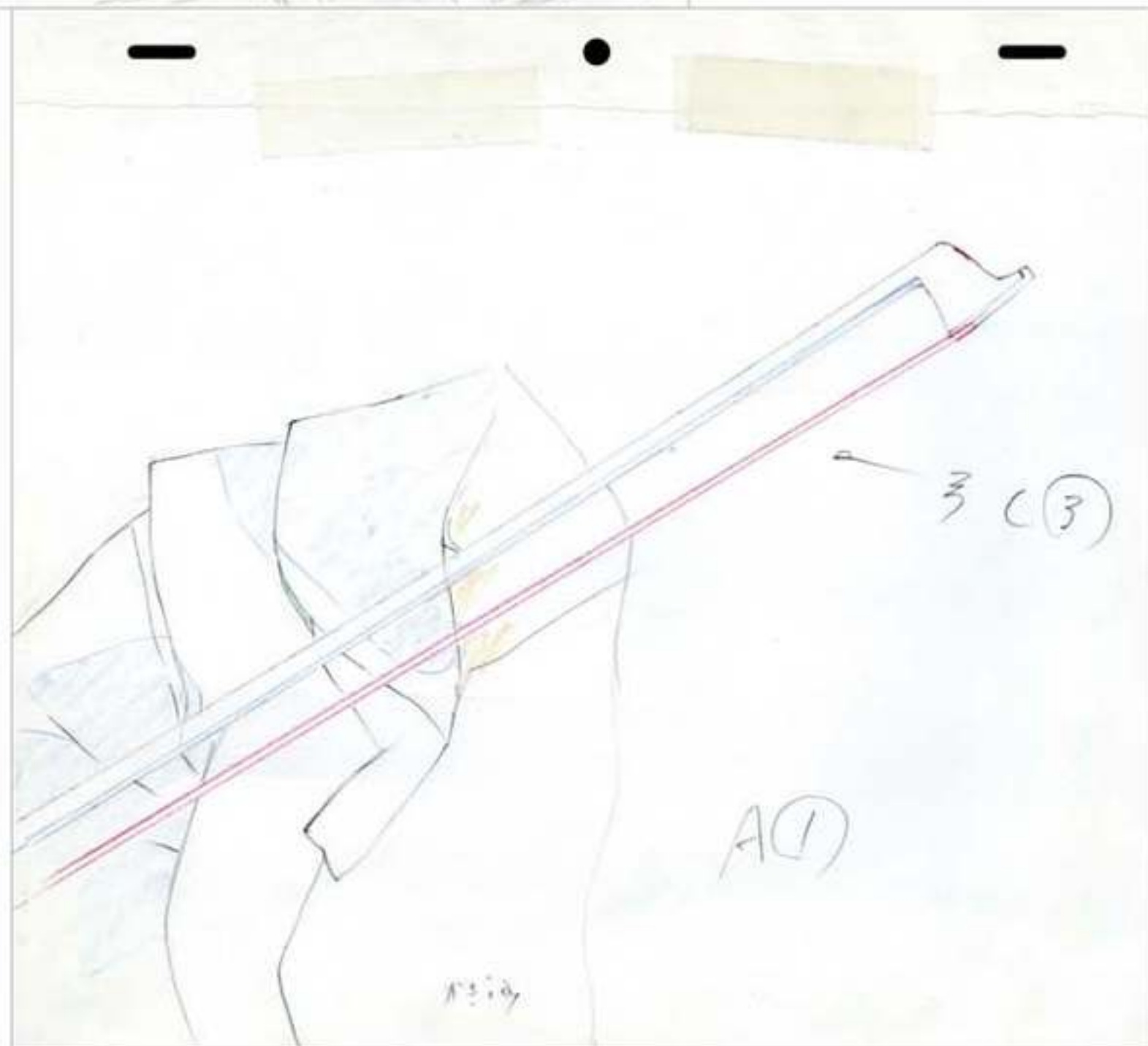



DEATH-680



AQ  
 117 B(2)  
 BX1(2)

DEATH-848  
 レイアウト修正



DEATH-708  
 レイアウト修正



DEATH-1182  
 修正原画



DEATH-733  
 レイアウト









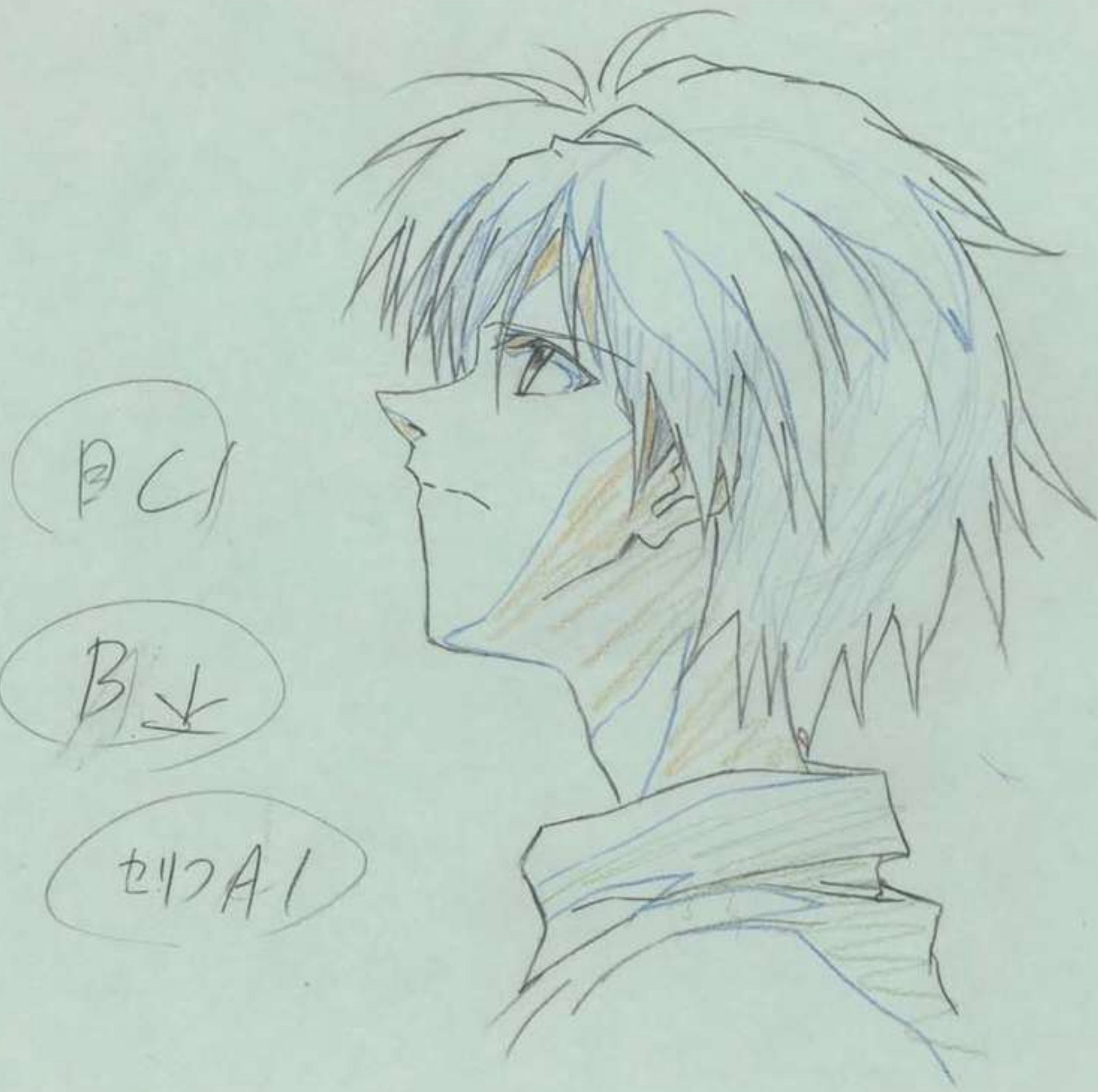



EVA  
S.DEATH C.1354

TIME (//+0)

PRODUCTION

IG

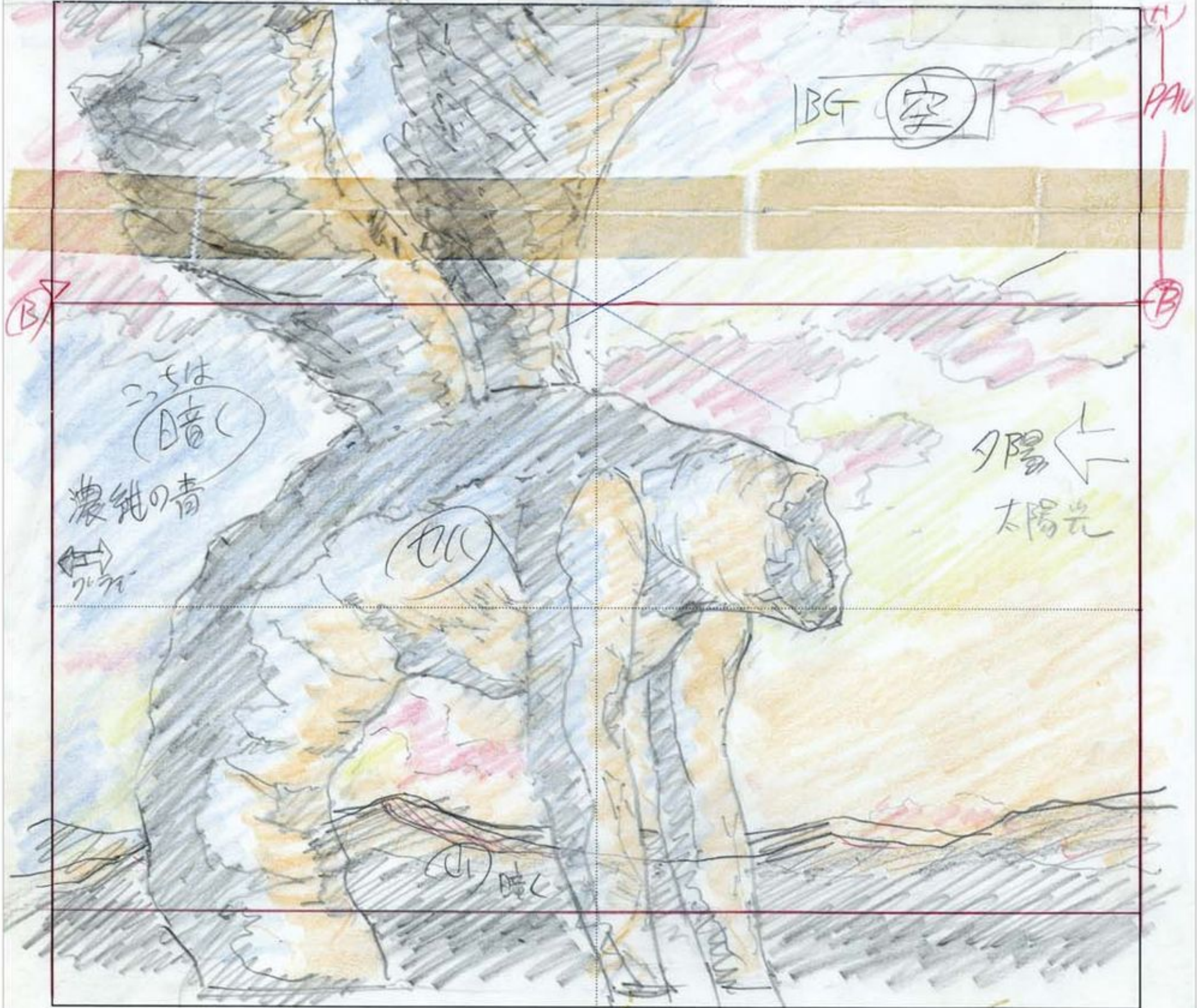

EVA: DEATH C-1355

上空は濃青(紺色)

TIME (5分) 有

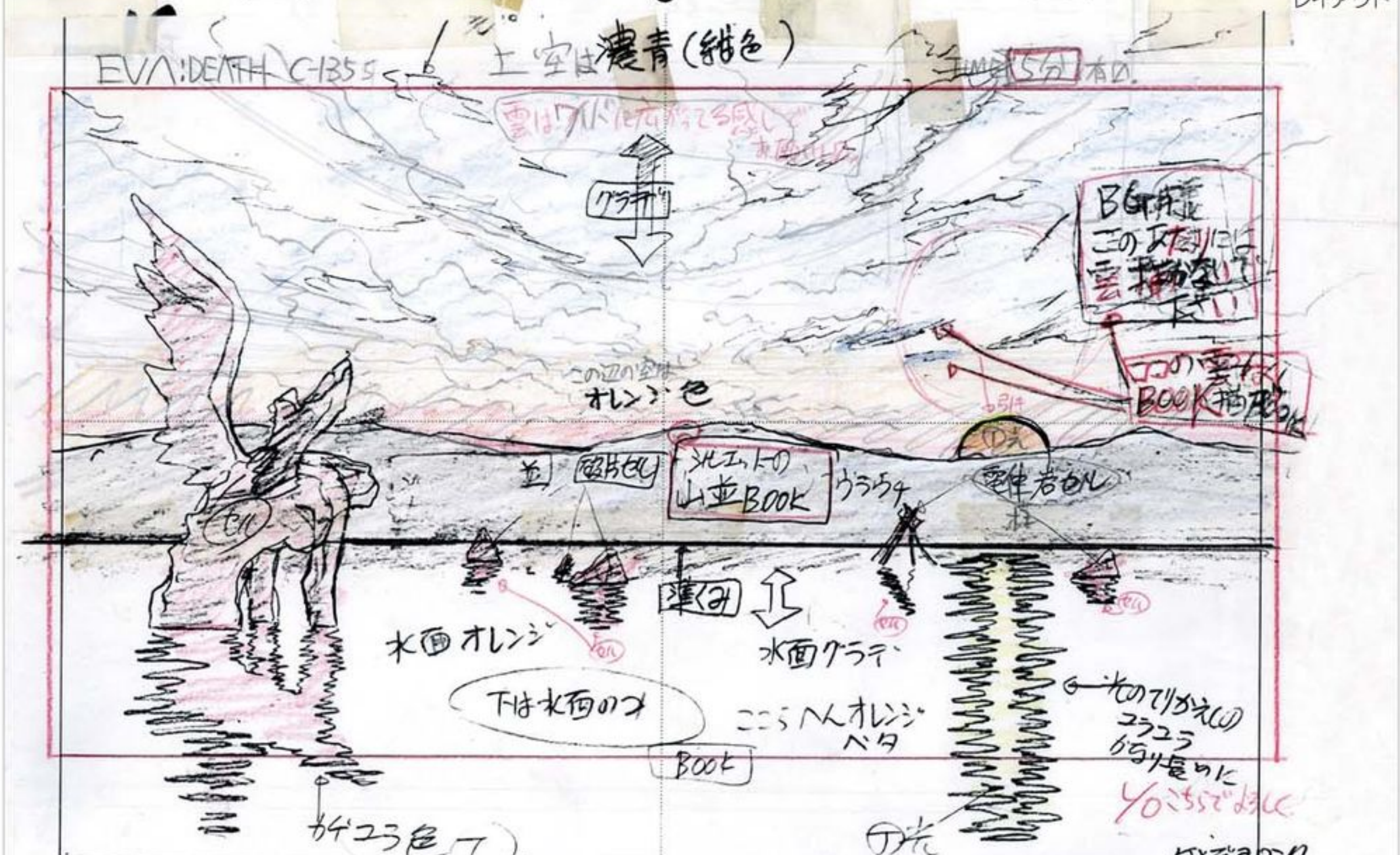

☆BG 様加藤様江、このCUTはDEATH...のENDクレジットに使われます。何とぞ、長Rが持つようお願いします。



全セル

#新25. (22)

A 盛 PAN



レイアウト修正

PAN-R 手=C  
修正レイアウト. 8K (5) 5 (2)

<全画セル> A 中 表情 B3  
レイ (5 2)



#25-新049  
修正原画

<全画セル> A 中

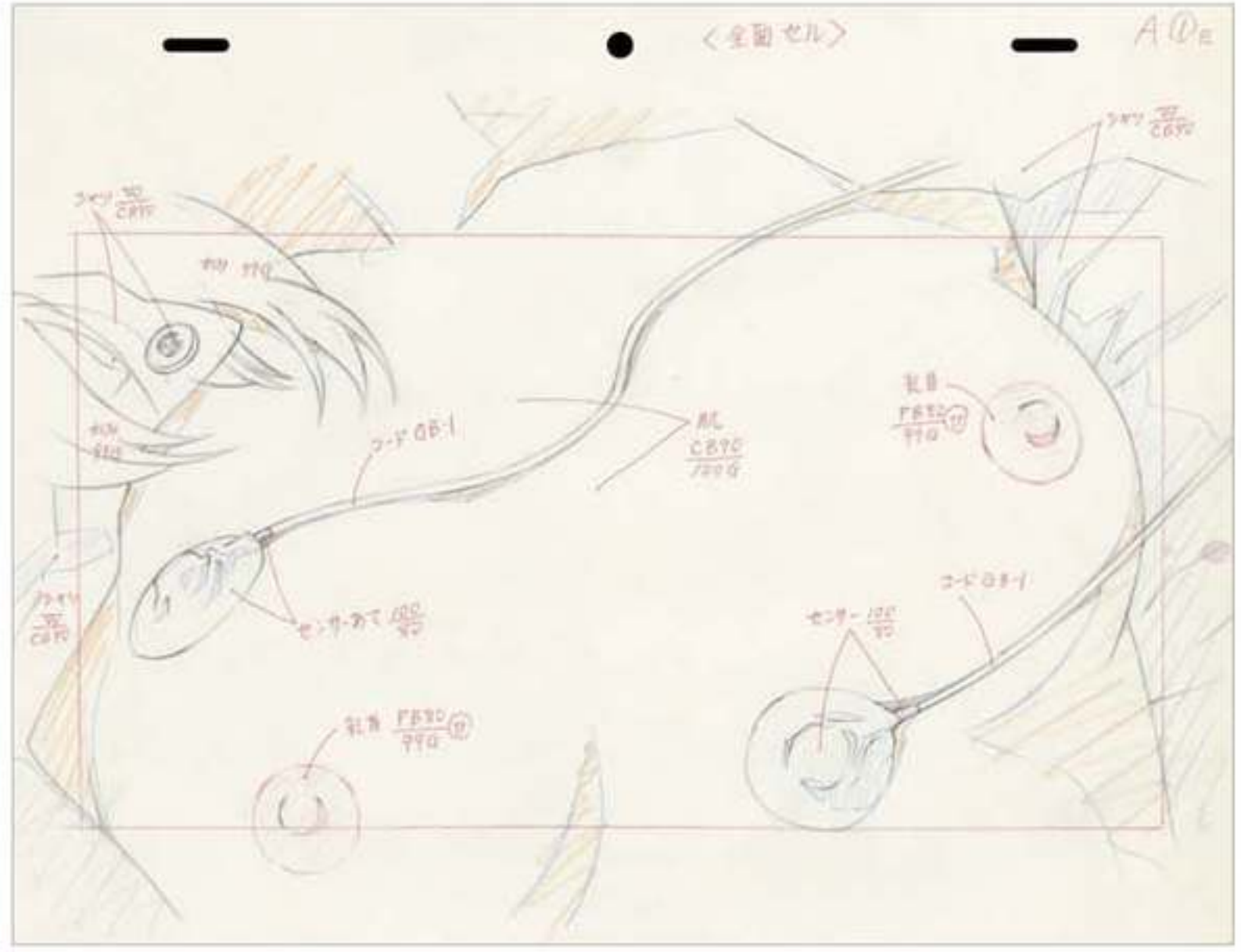

#25-新026F

原画

0123  
原



#25-新061  
修正原画

L-57



#25-新057  
レイアウト修正



B-7 修



1/2  
2/2  
D-3

中身

A-1 修



左身  
B-1

1/2  
D-4 修

B-8 修

1/2  
D-2 3



B-6 修



1/2  
D-2

A-1 修

1/2  
B-3 修





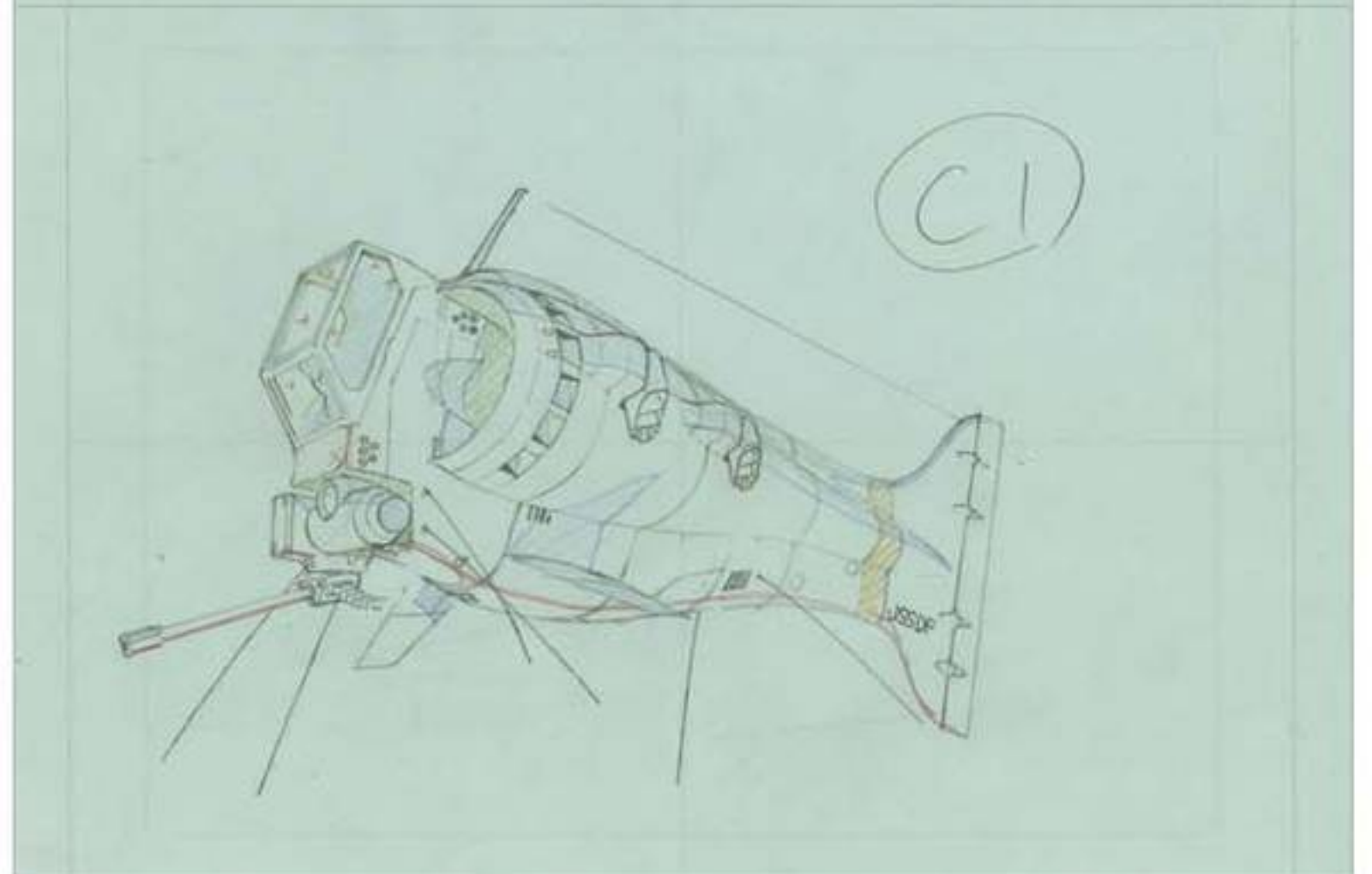
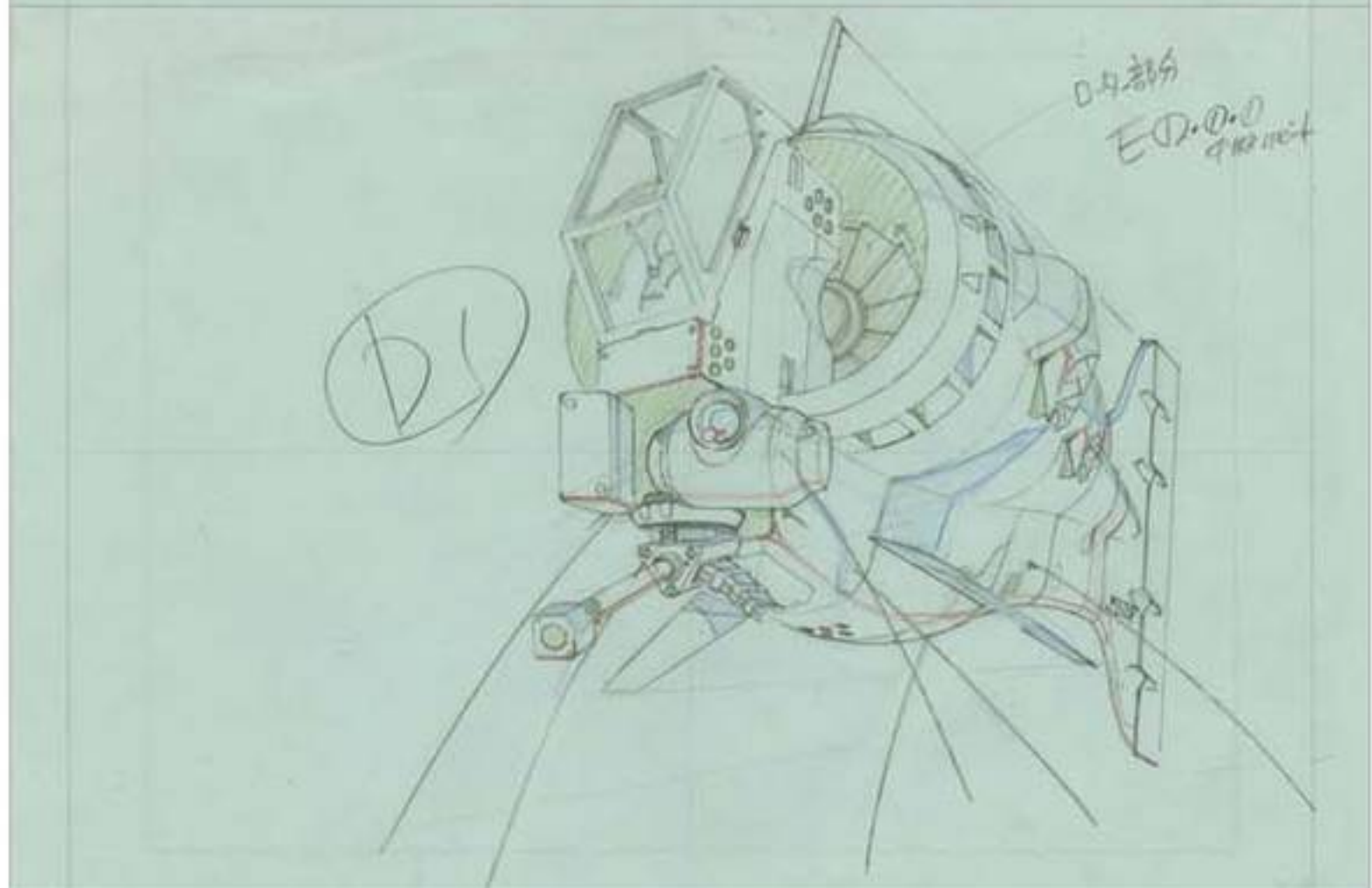
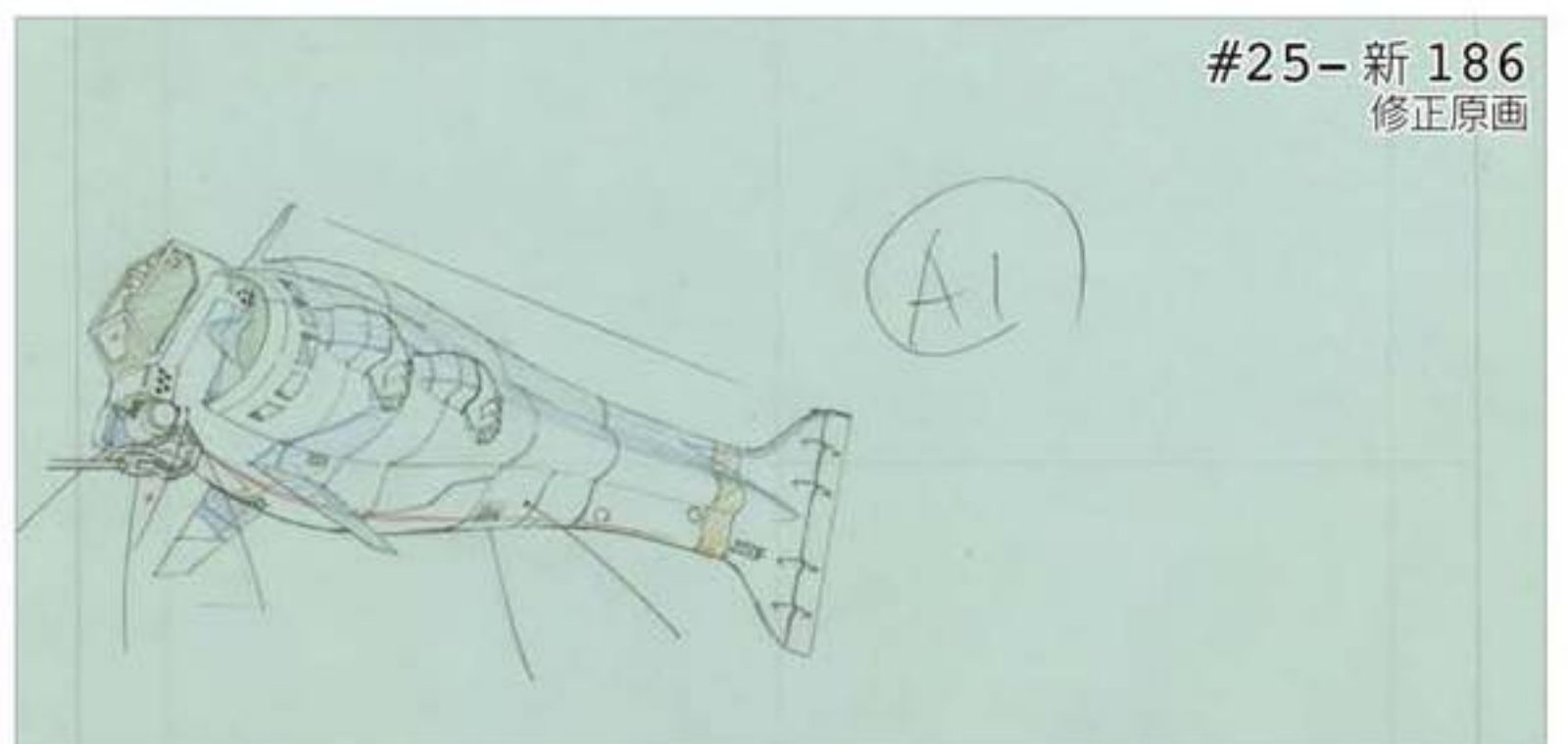
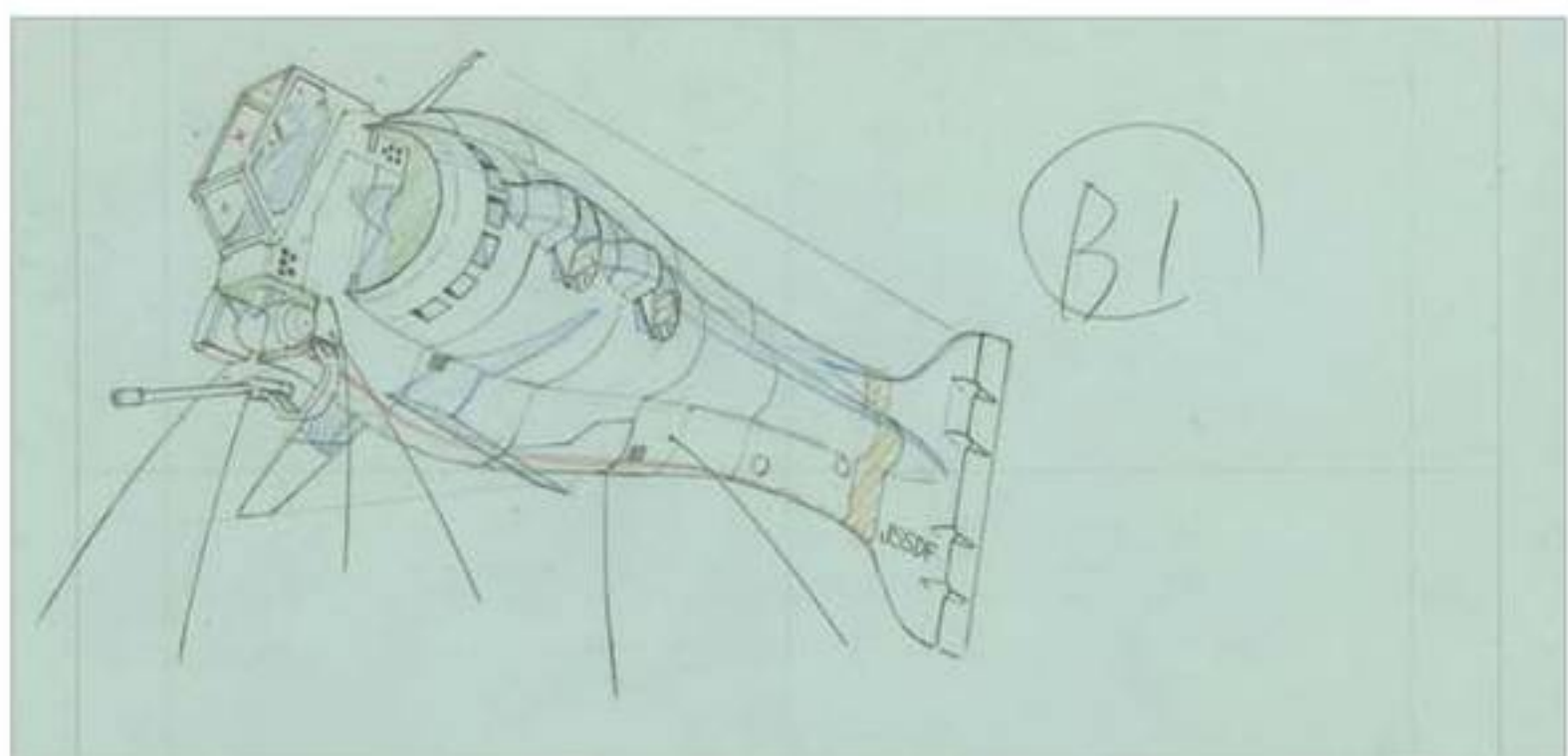
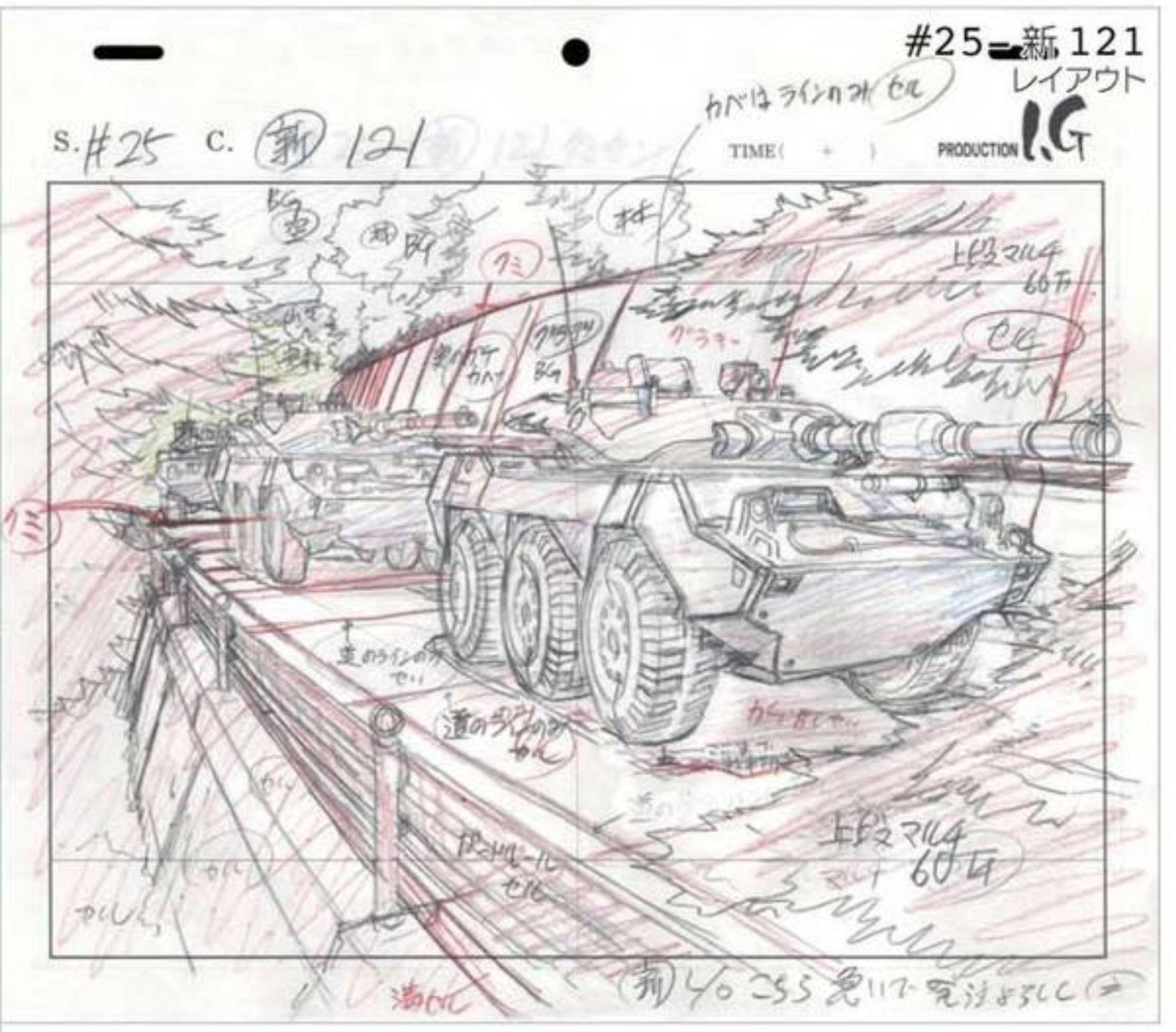
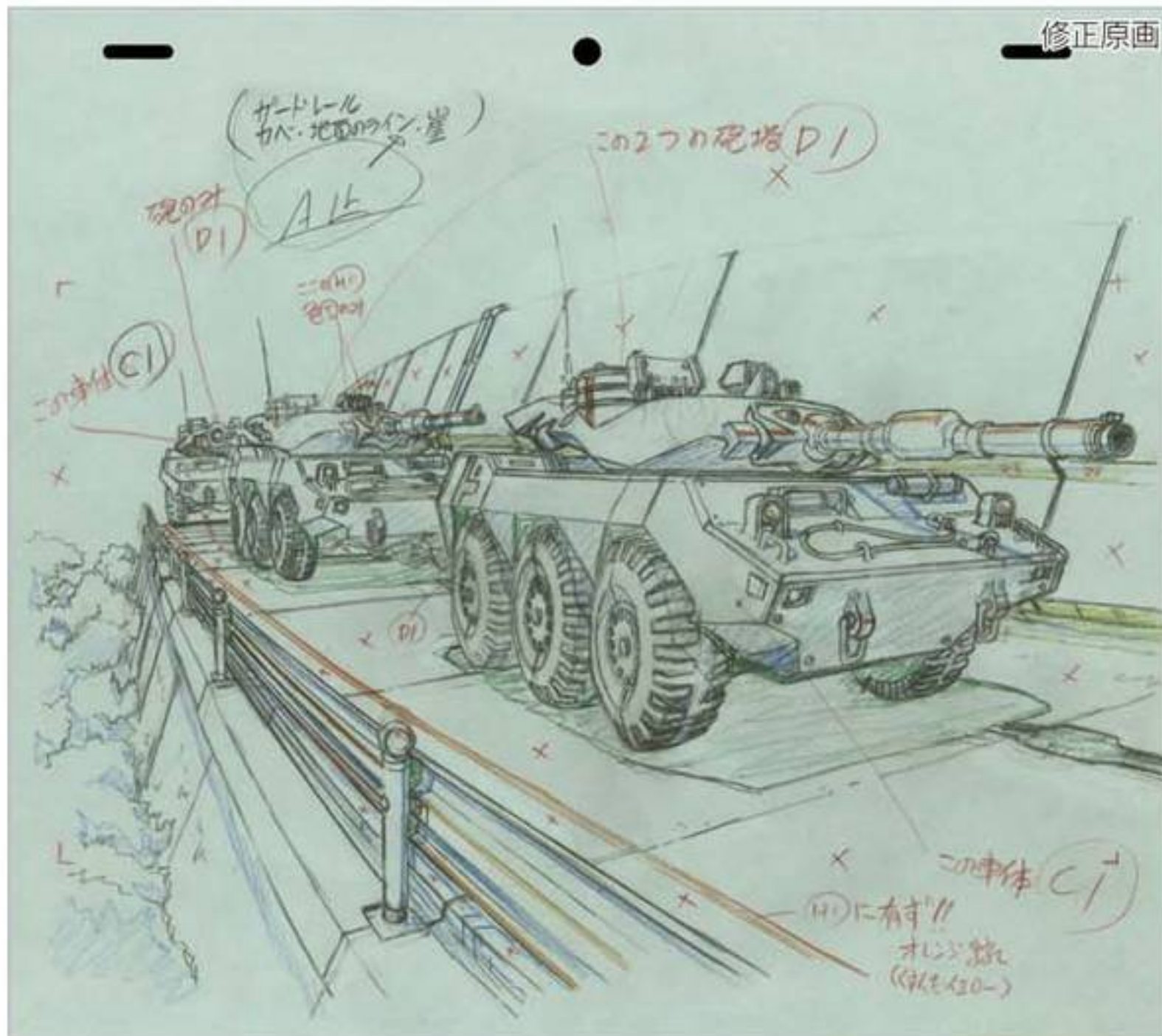
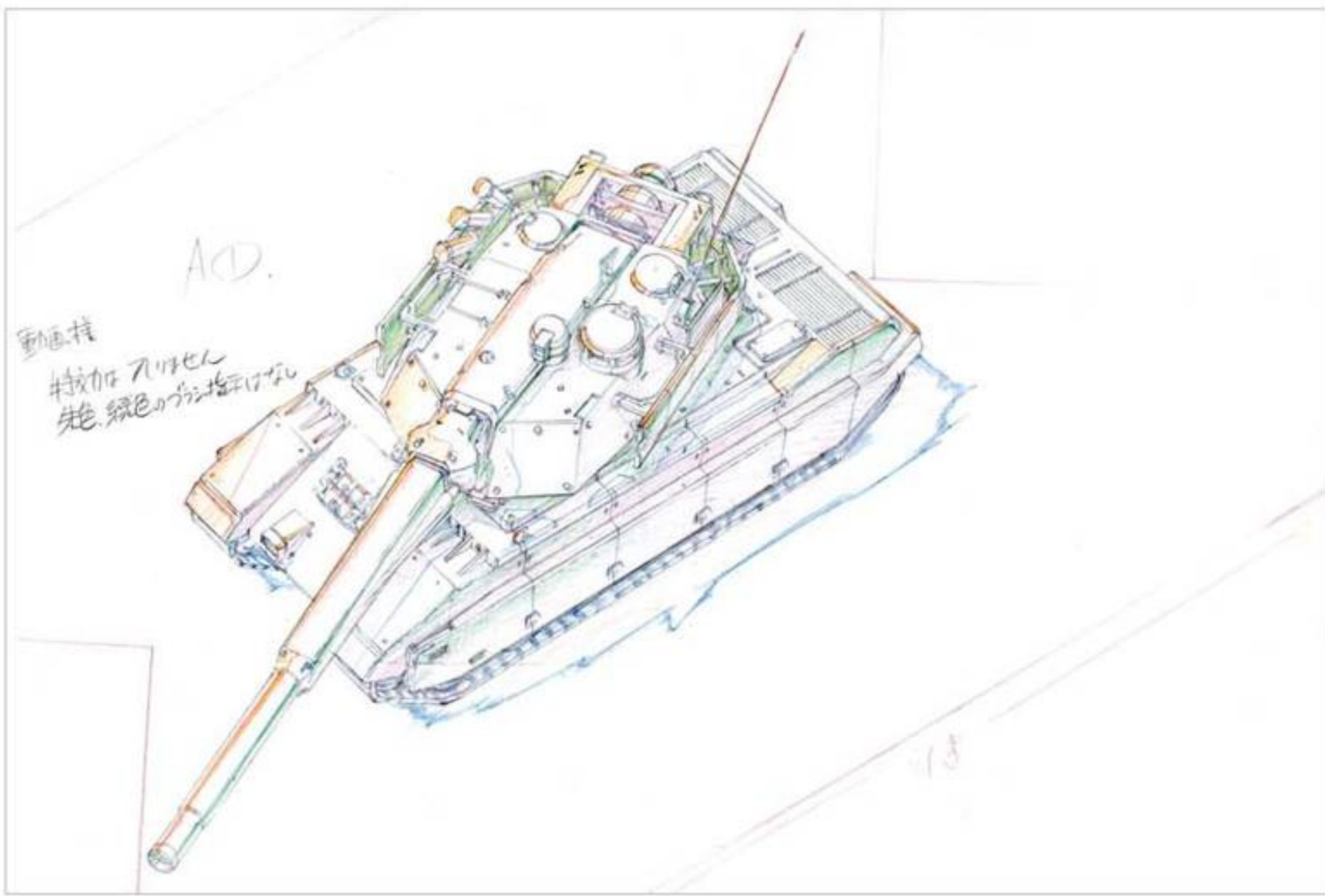



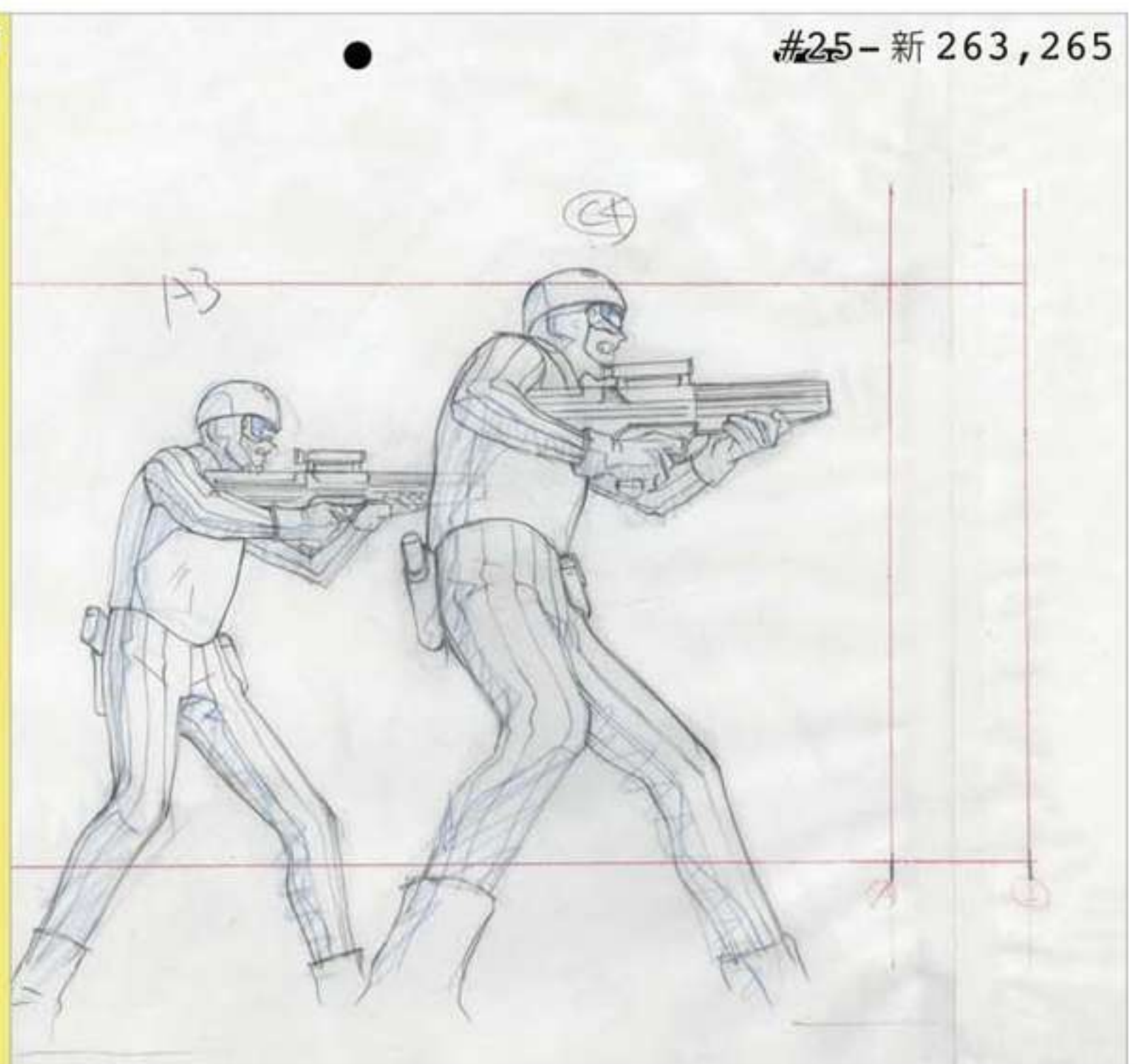
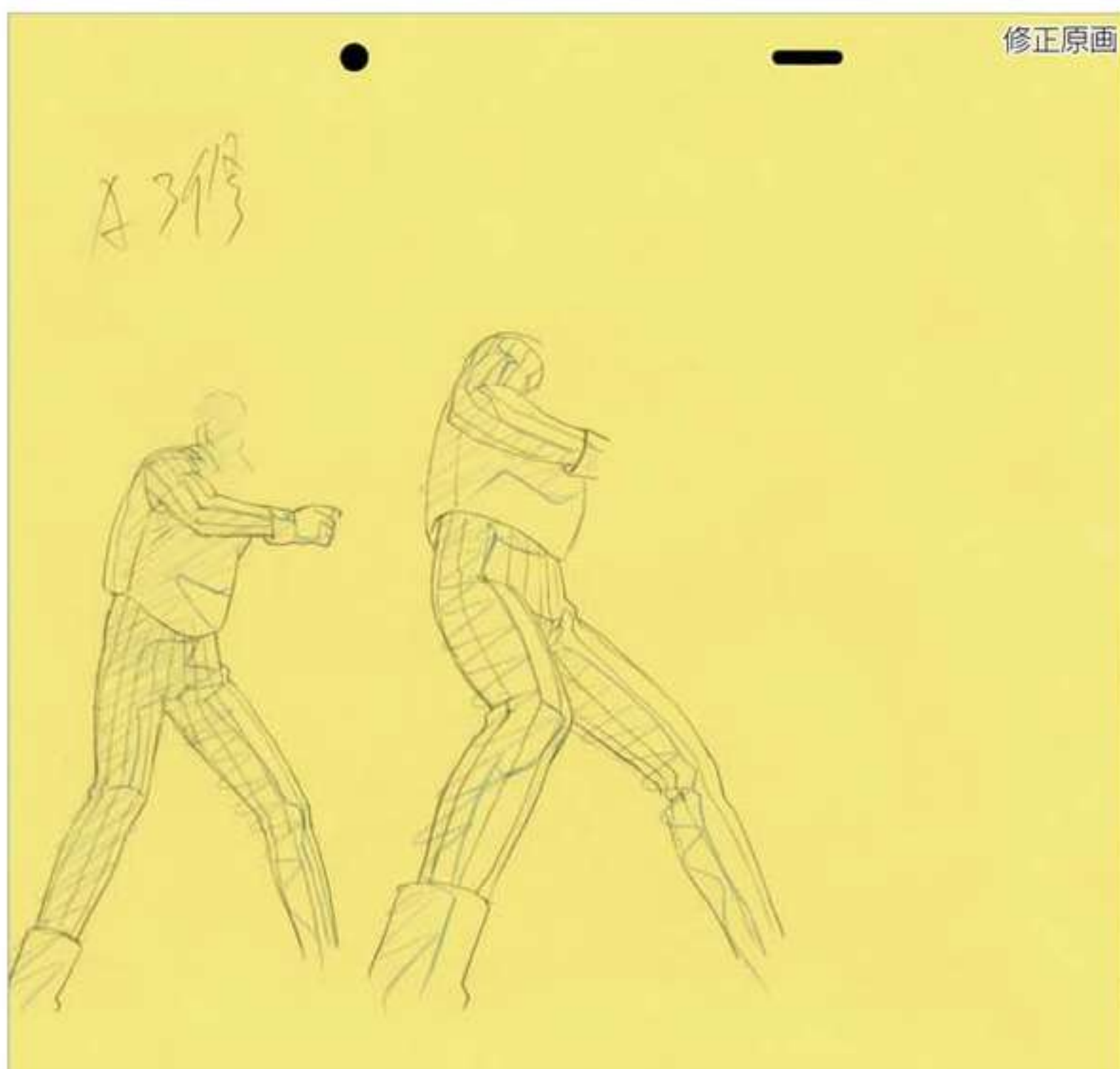



C-513

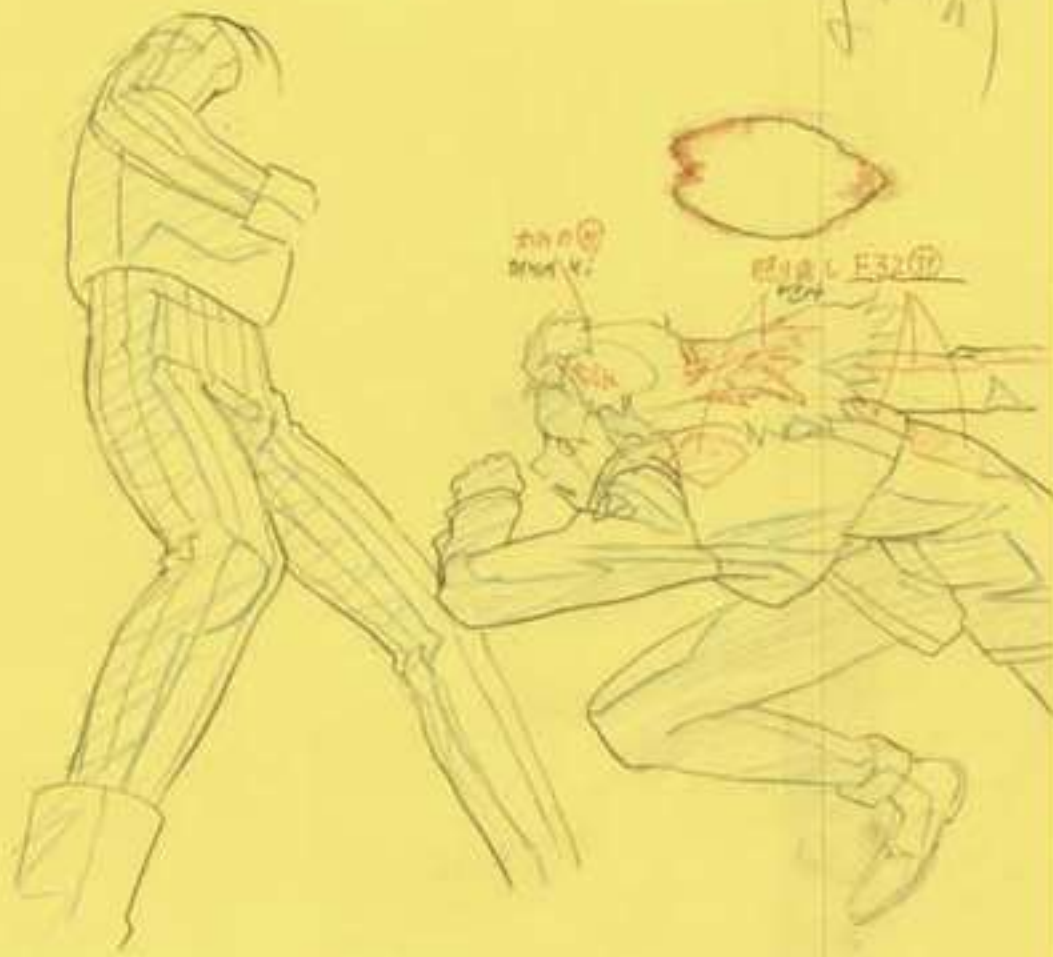

C-613



C6



C7

13



C7





C8A



C8



C9A

右肩色紙



C9

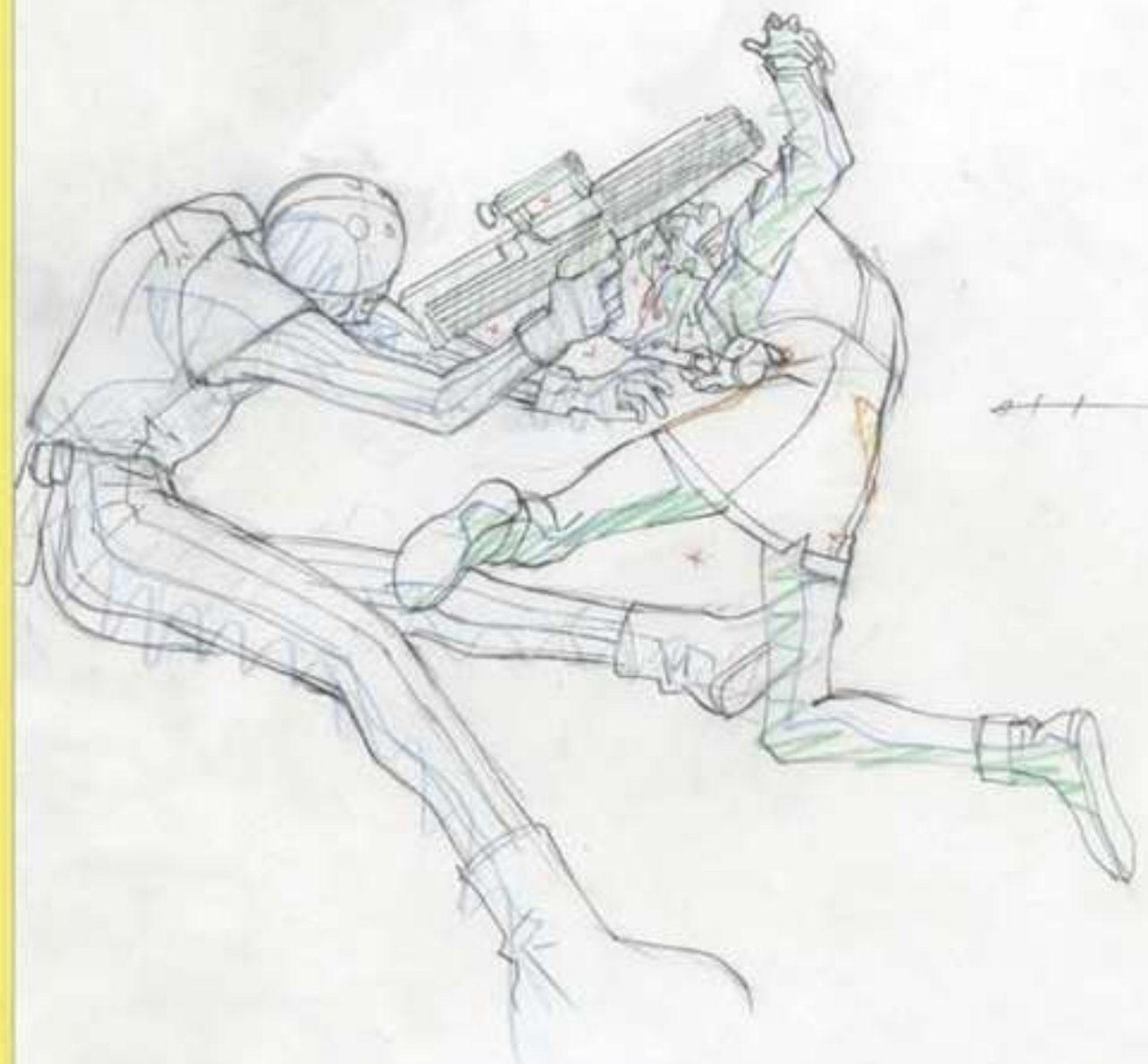

C10A



C10



3	X	4	X	0
4	X	4	X	0
5	X	4	X	7
6	X	4	X	14
7	X	4	X	14
8	X	4	X	14
9	X	4	X	14
10	X	4	X	14
11	X	4	X	14
12	X	4	X	14
13	X	4	X	14
14	X	4	X	14
15	X	4	X	14
16	X	4	X	14
17	X	4	X	14
18	X	4	X	14
19	X	4	X	14
20	X	4	X	14
21	X	4	X	14
22	X	4	X	14
23	X	4	X	14
24	X	4	X	14
25	X	4	X	14
26	X	4	X	14
27	X	4	X	14
28	X	4	X	14
29	X	4	X	14
30	X	4	X	14
31	X	4	X	14
32	X	4	X	14
33	X	4	X	14
34	X	4	X	14
35	X	4	X	14



ABC  
カク

#25-新295  
タイムシート

#25-新295  
レイアウト

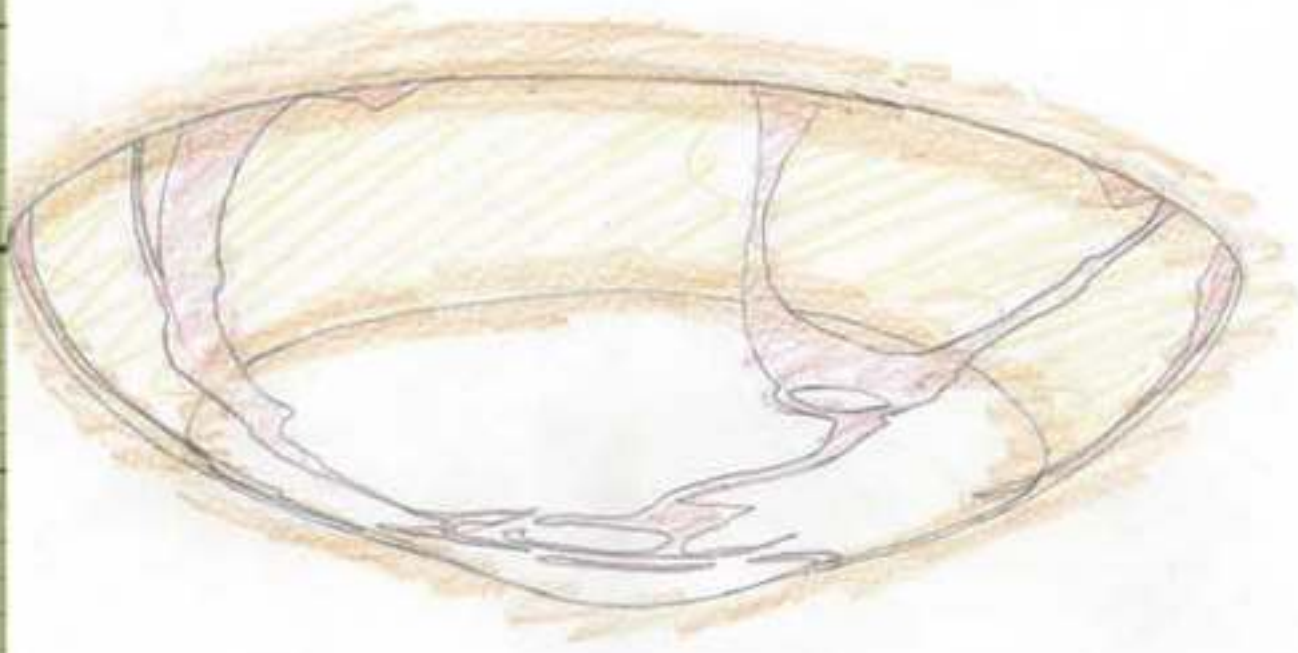

201P  
+  
777  
(A1)

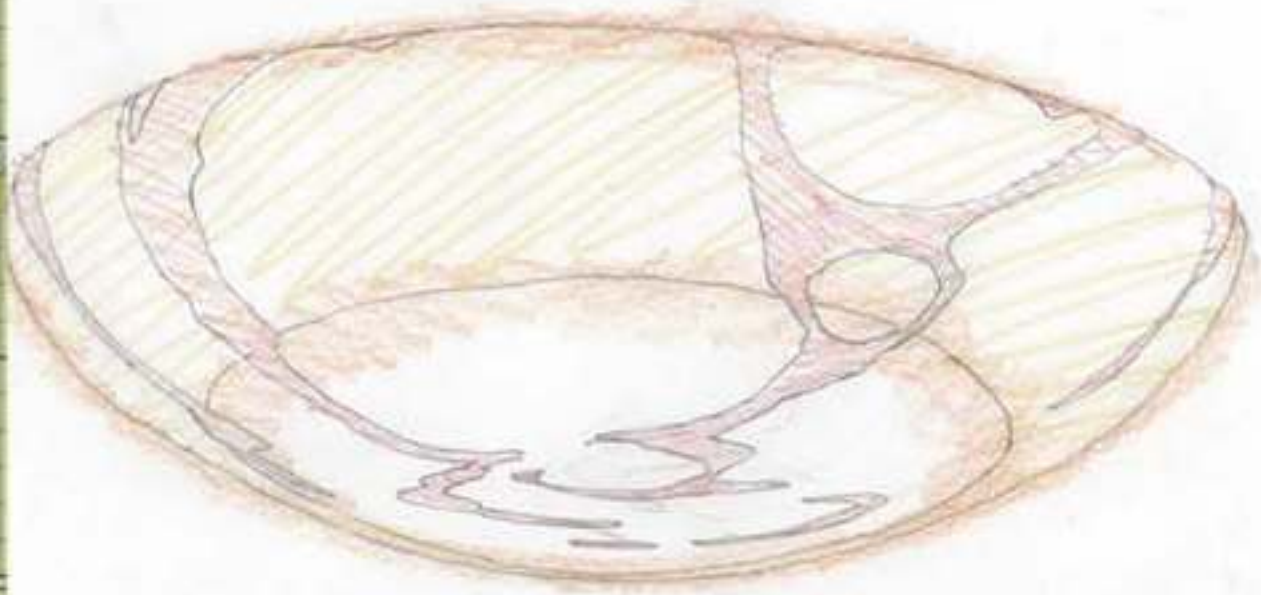

(A2) 201P  
+  
777

ABC

カク

カク

カク

カク

カク

カク

カク

カク

カク

カク

カク

カク

カク

カク

カク

カク

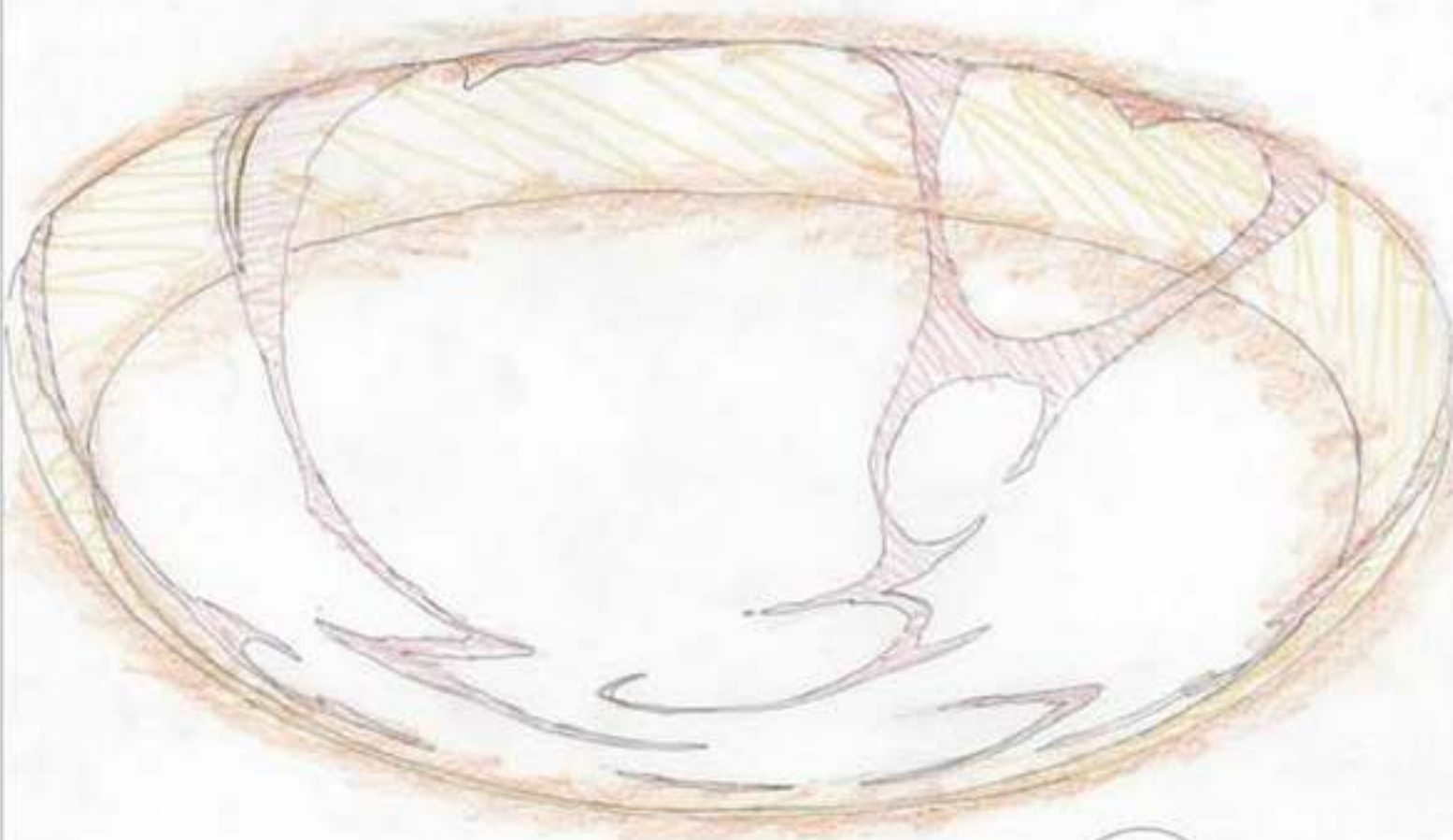

(A3)

S.

C.

TIME ( + )

PRODUCTION LG

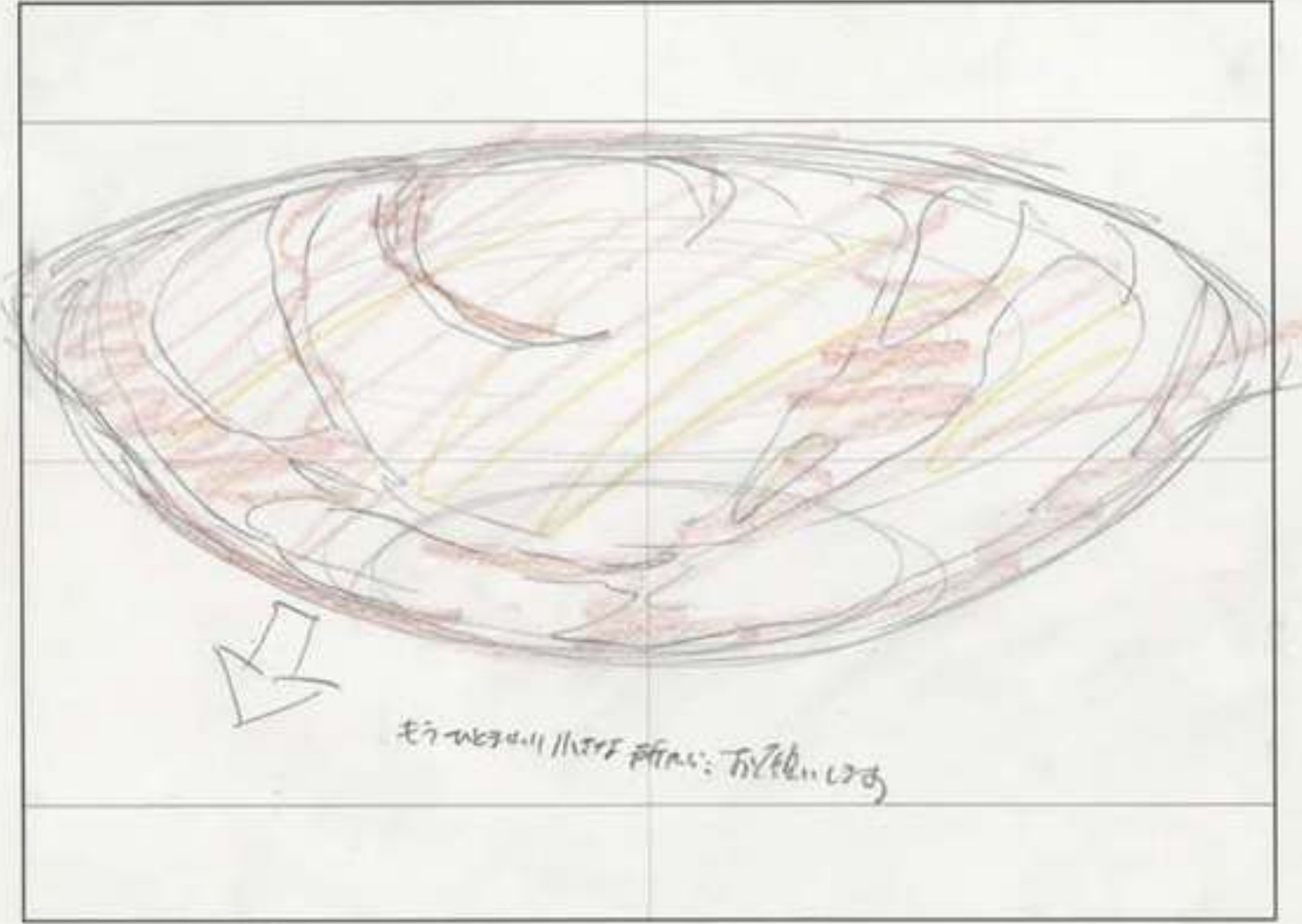

(1)

S. #25

C. 295

TIME ( 3+12 )

PRODUCTION LG

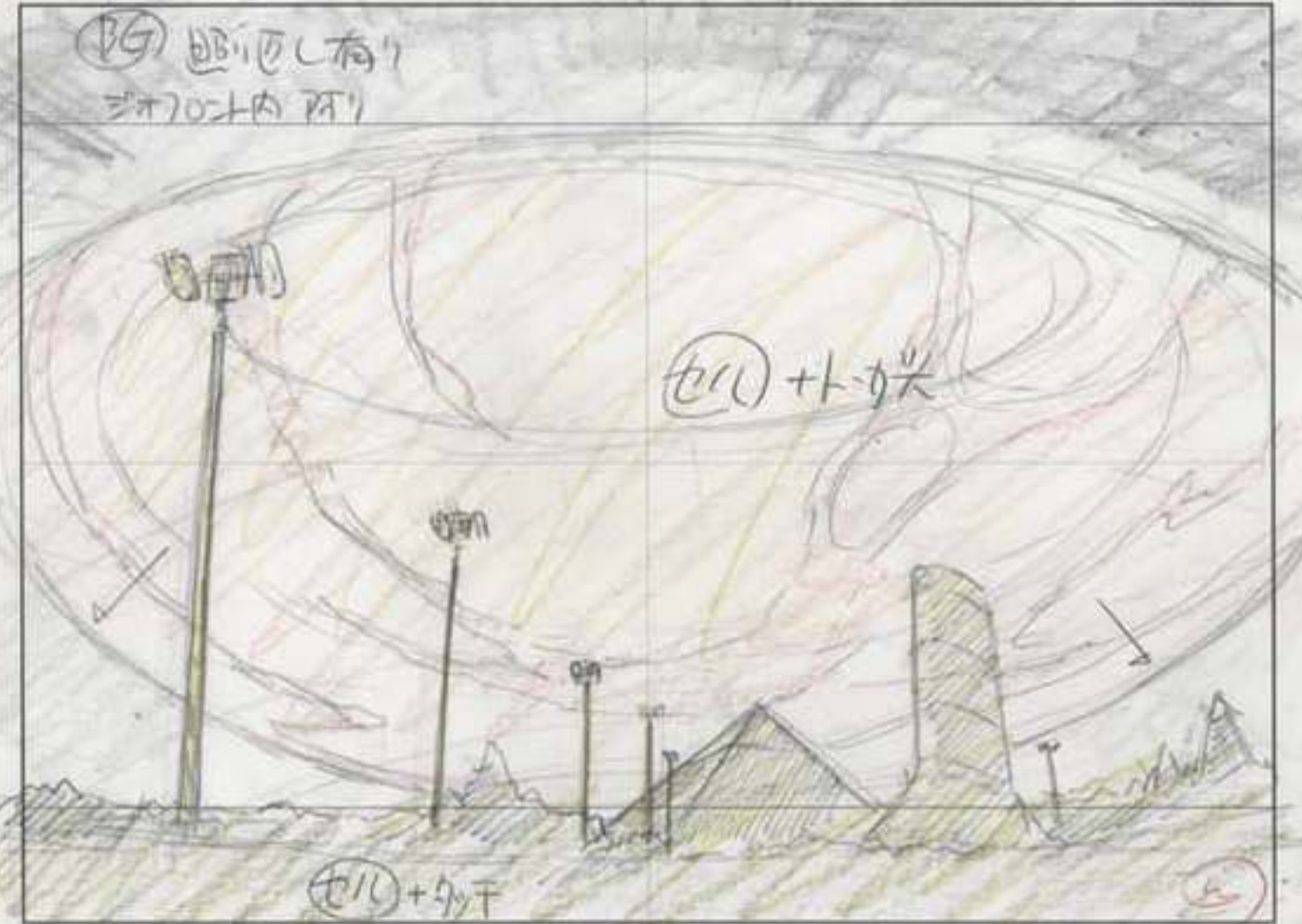

(B) 201P  
+  
777

(C) + 777

(C) + 777

(2)

S.

C.

TIME ( + )

PRODUCTION LG

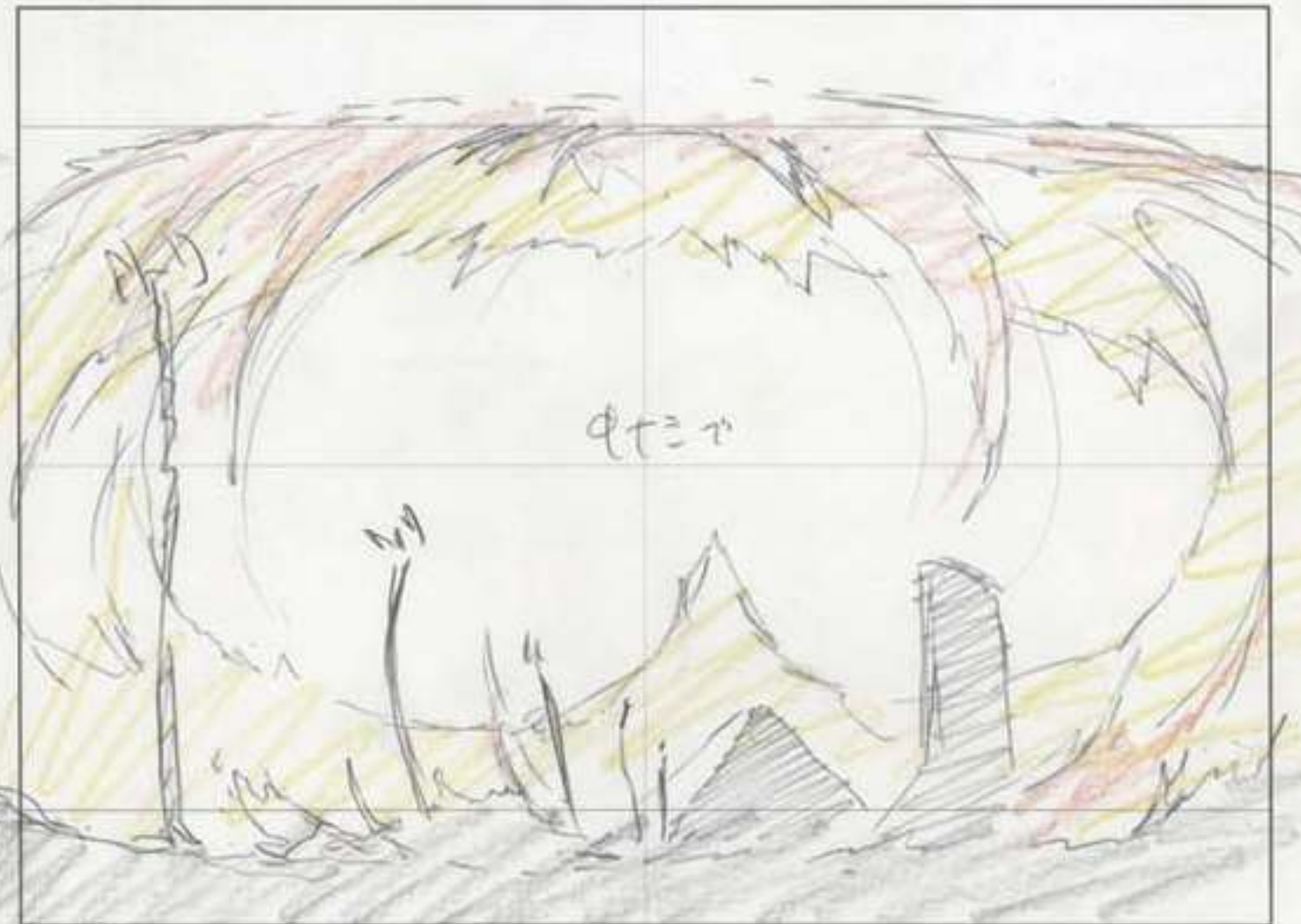

(C) + 777

(3)



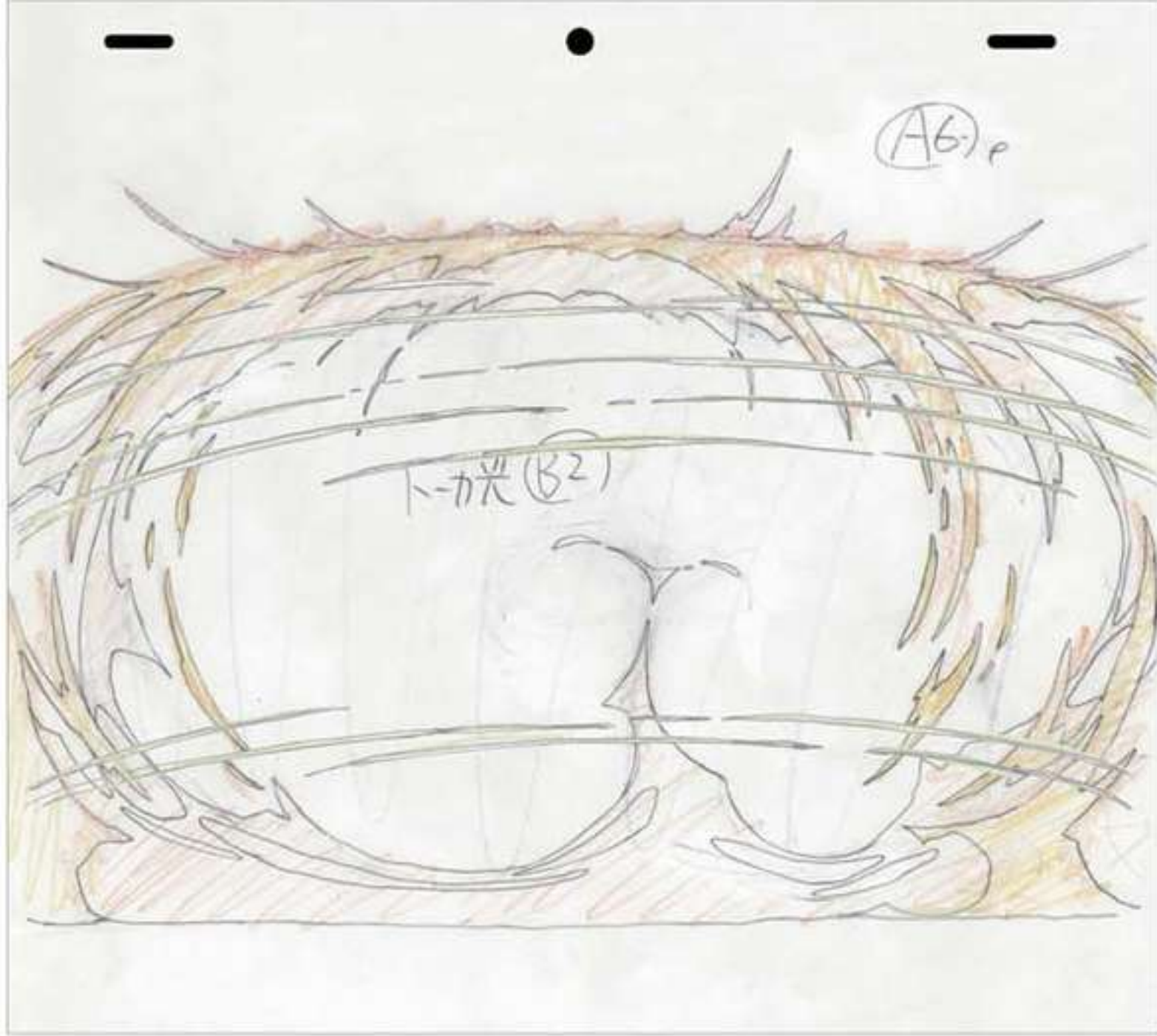
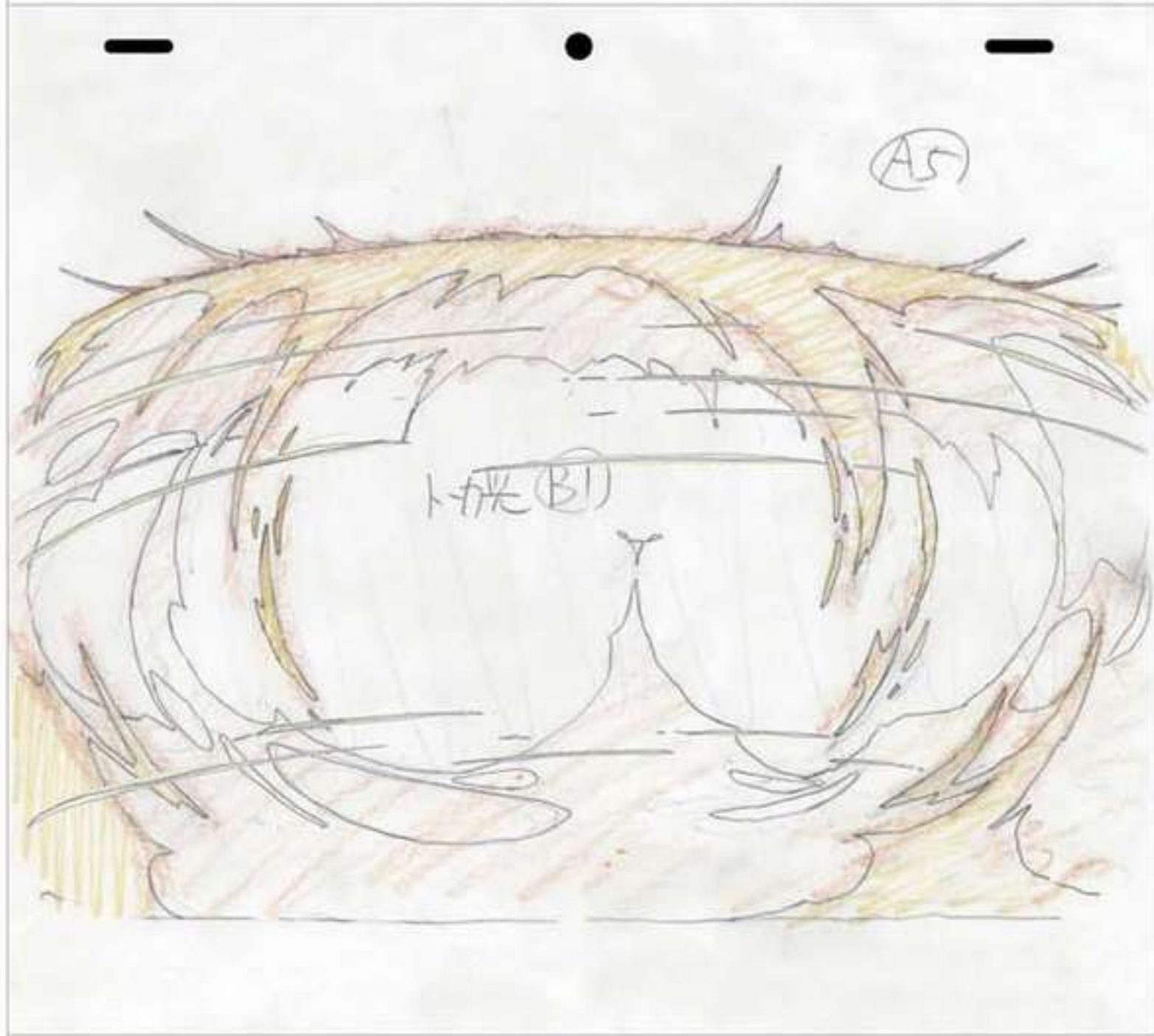
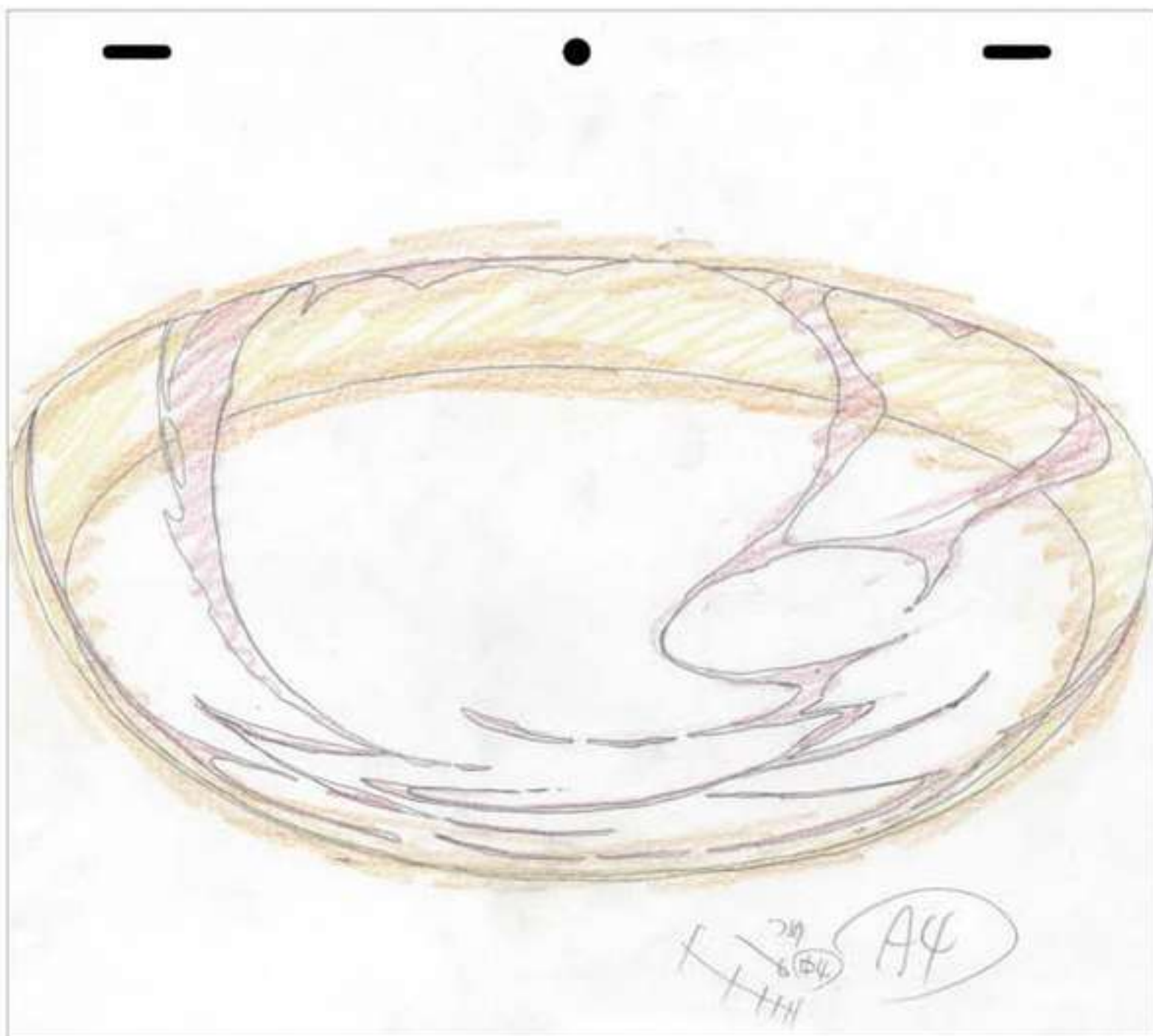
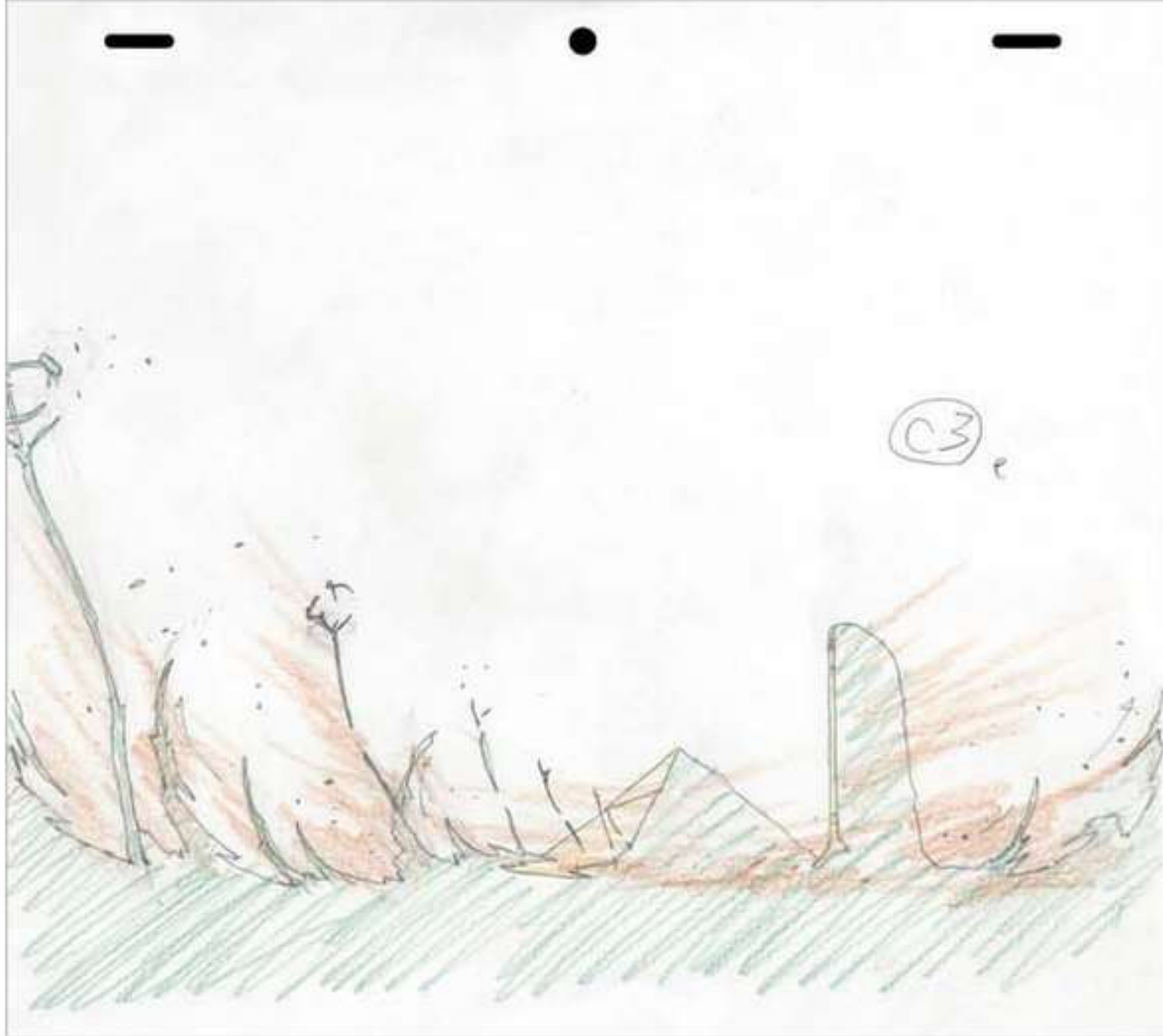
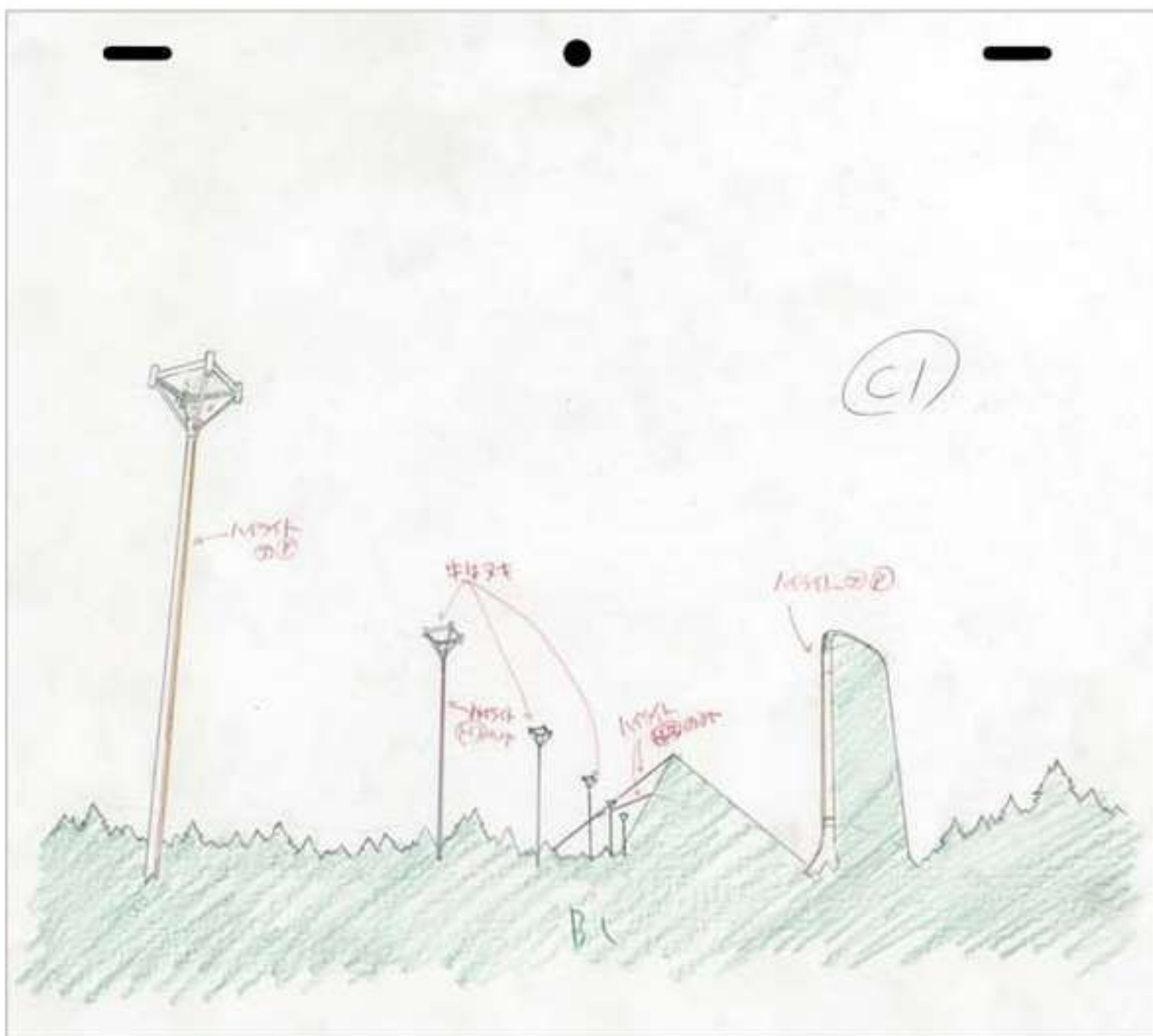



#25-新 332  
レイアウト修正

C332



C-332



#25-新 347  
レイアウト修正

S.#25 C. 347 BG (1) 1-214

TIME ( + ) I.G (株) アイリータツノコ TATSUNOKO



AD

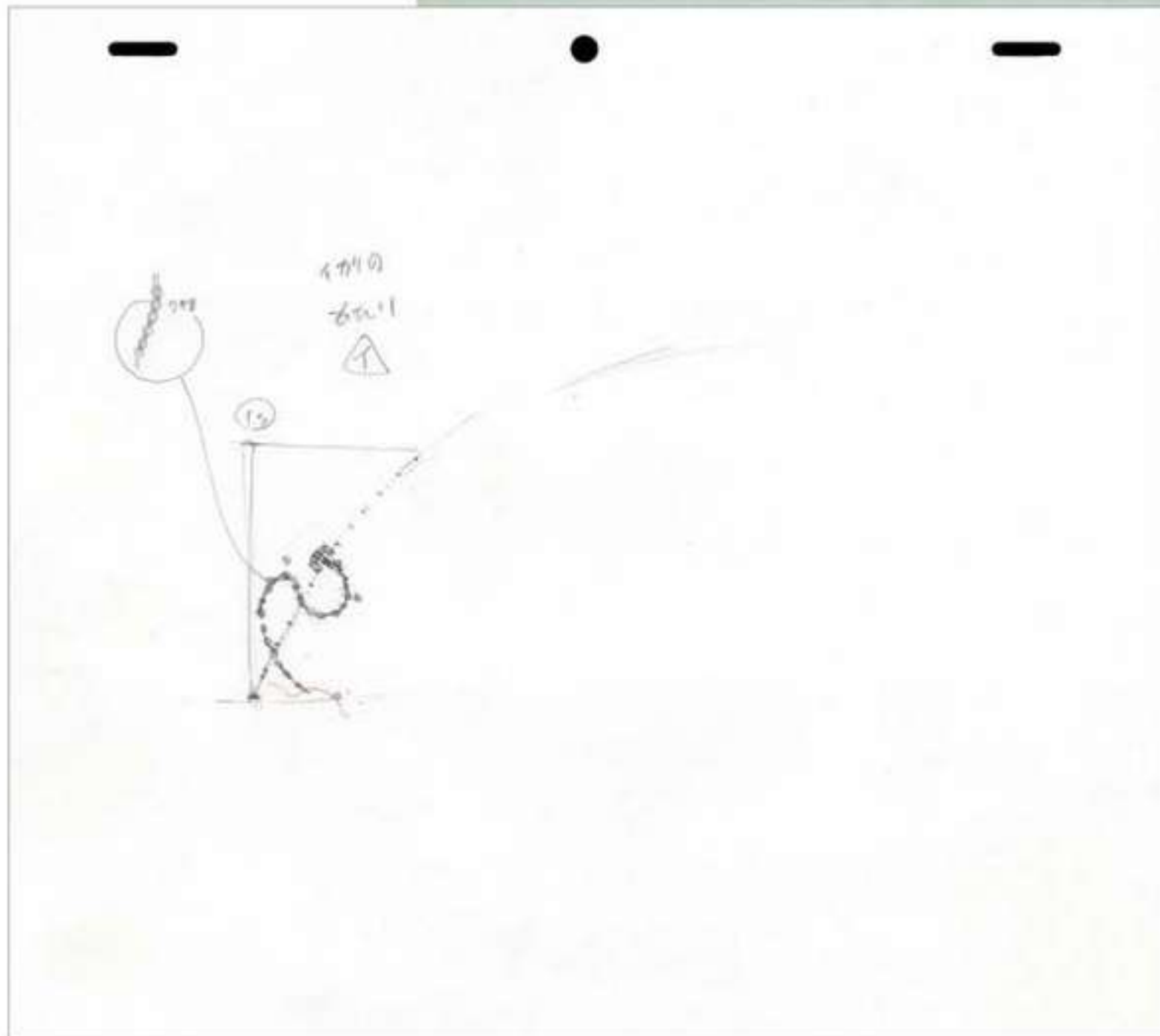















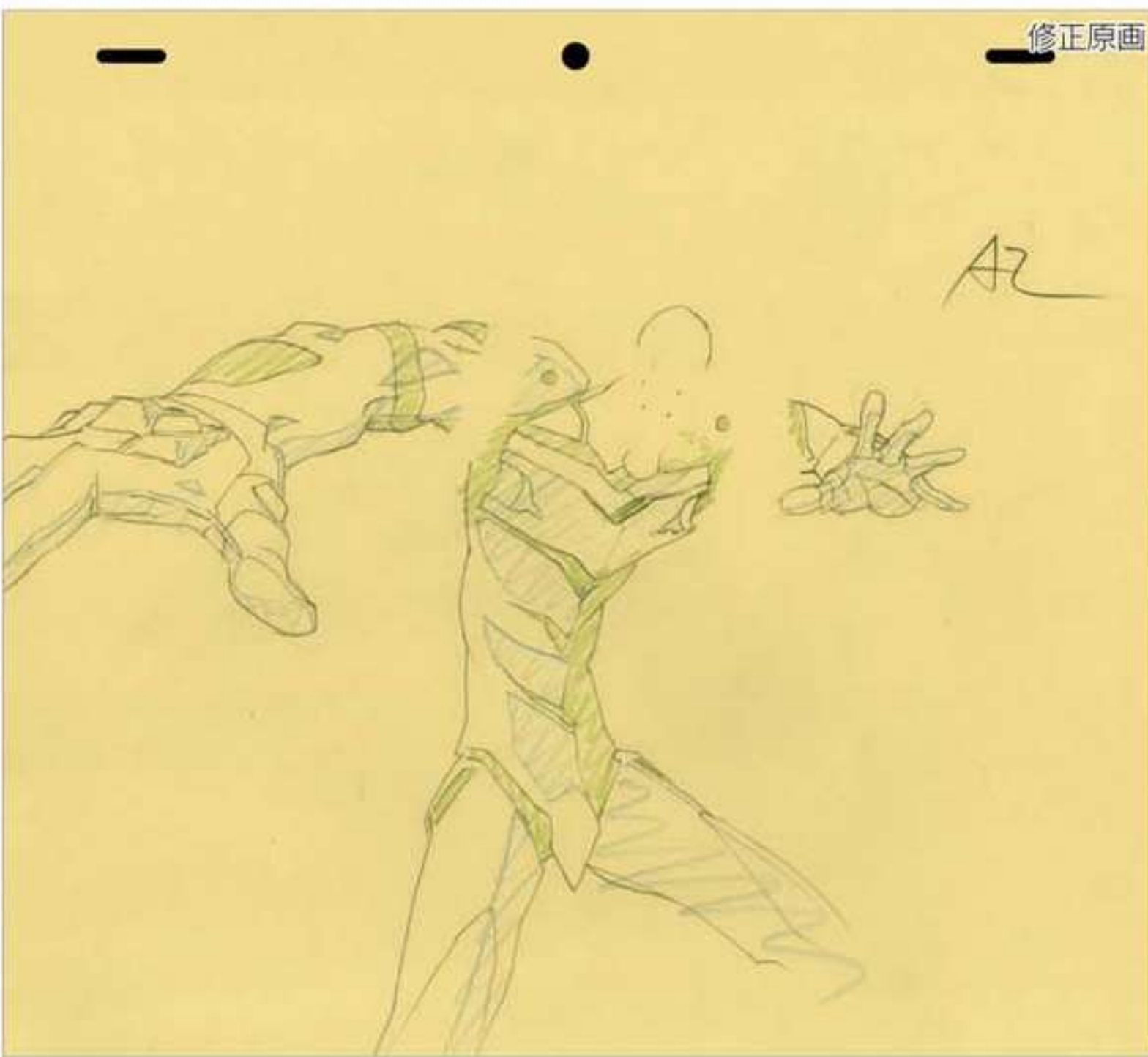



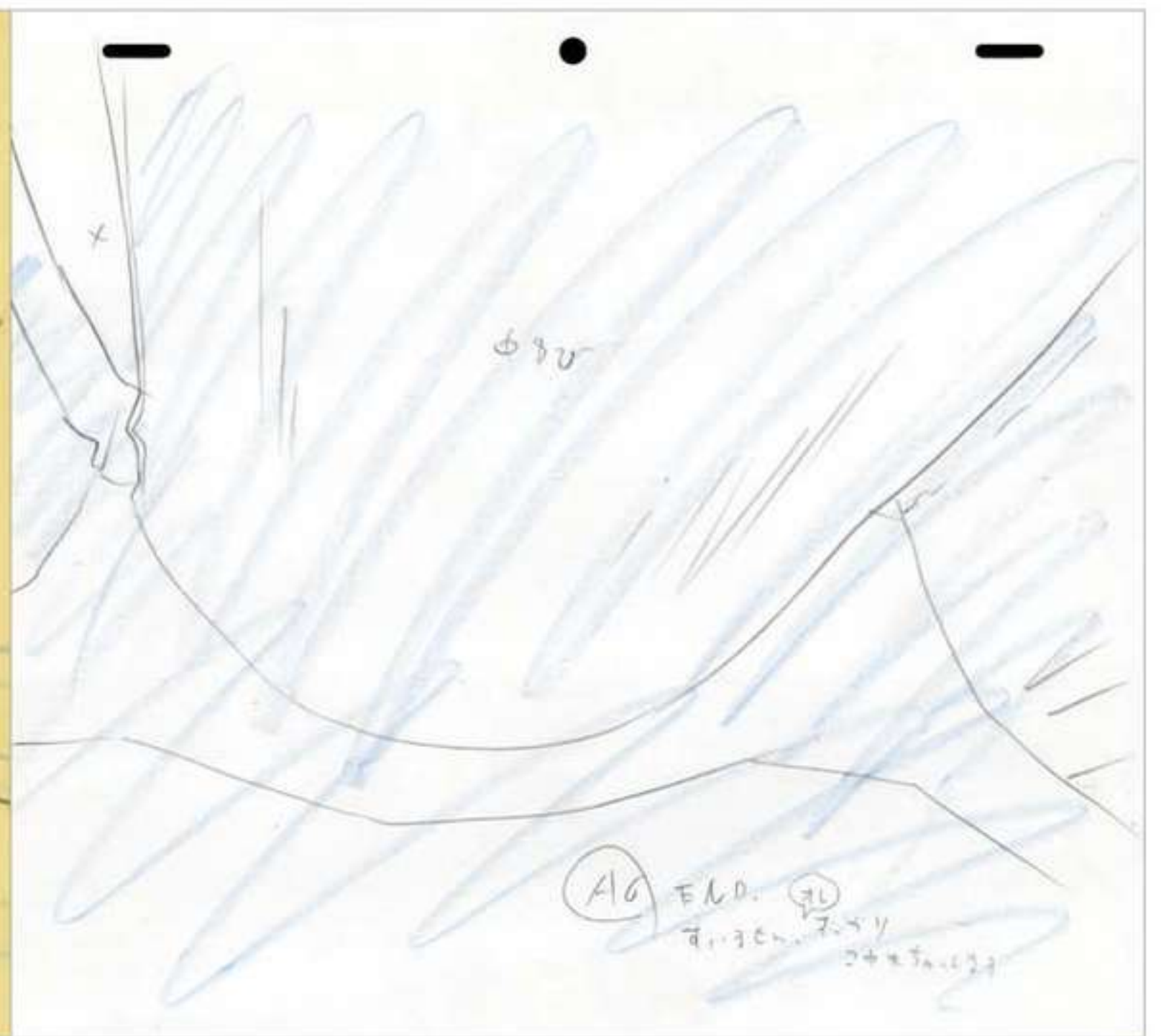
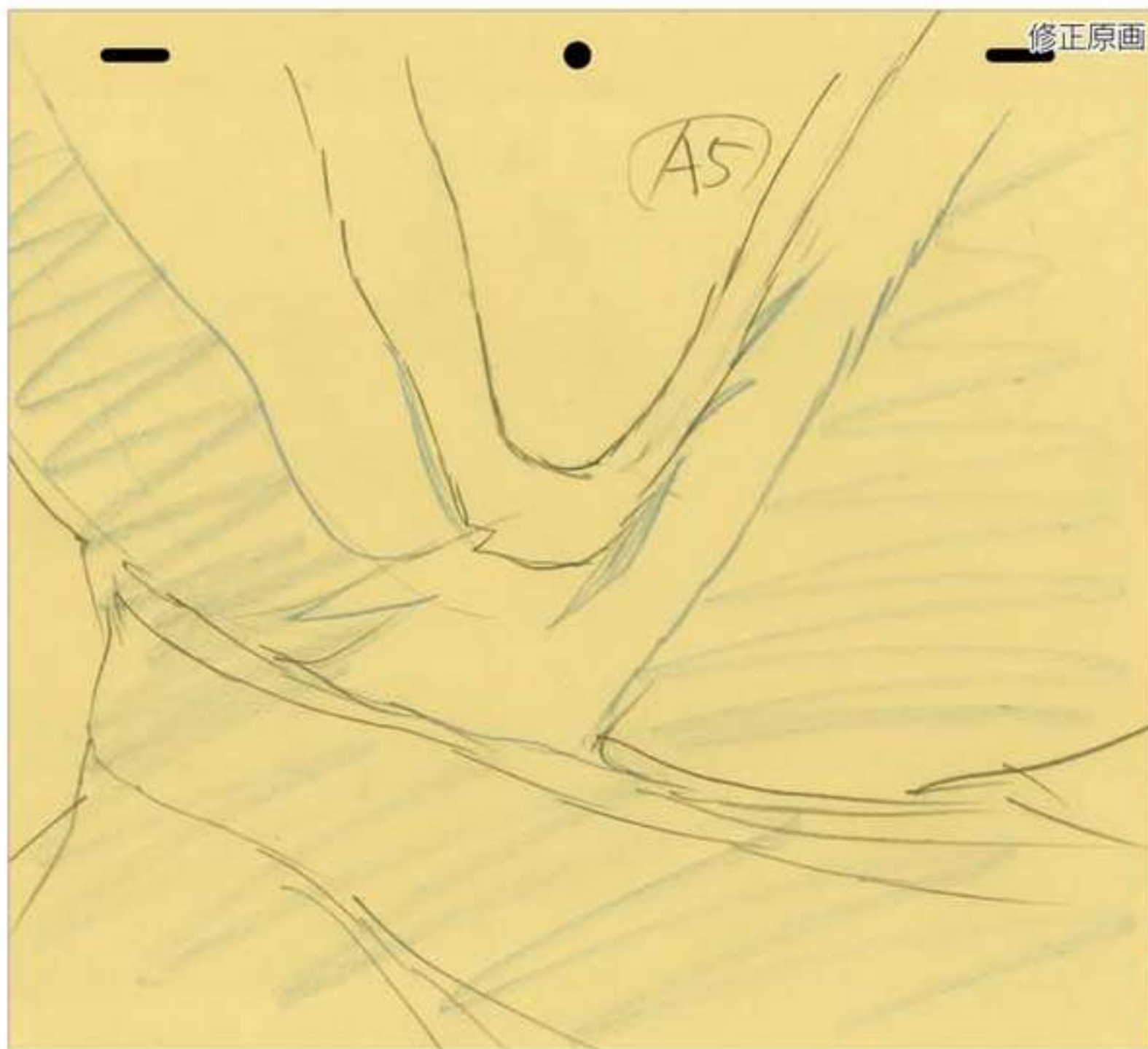

#25-新 390  
レイアウト修正



#25-新 383  
タイムシート









#25

0-613

1/3 = 532

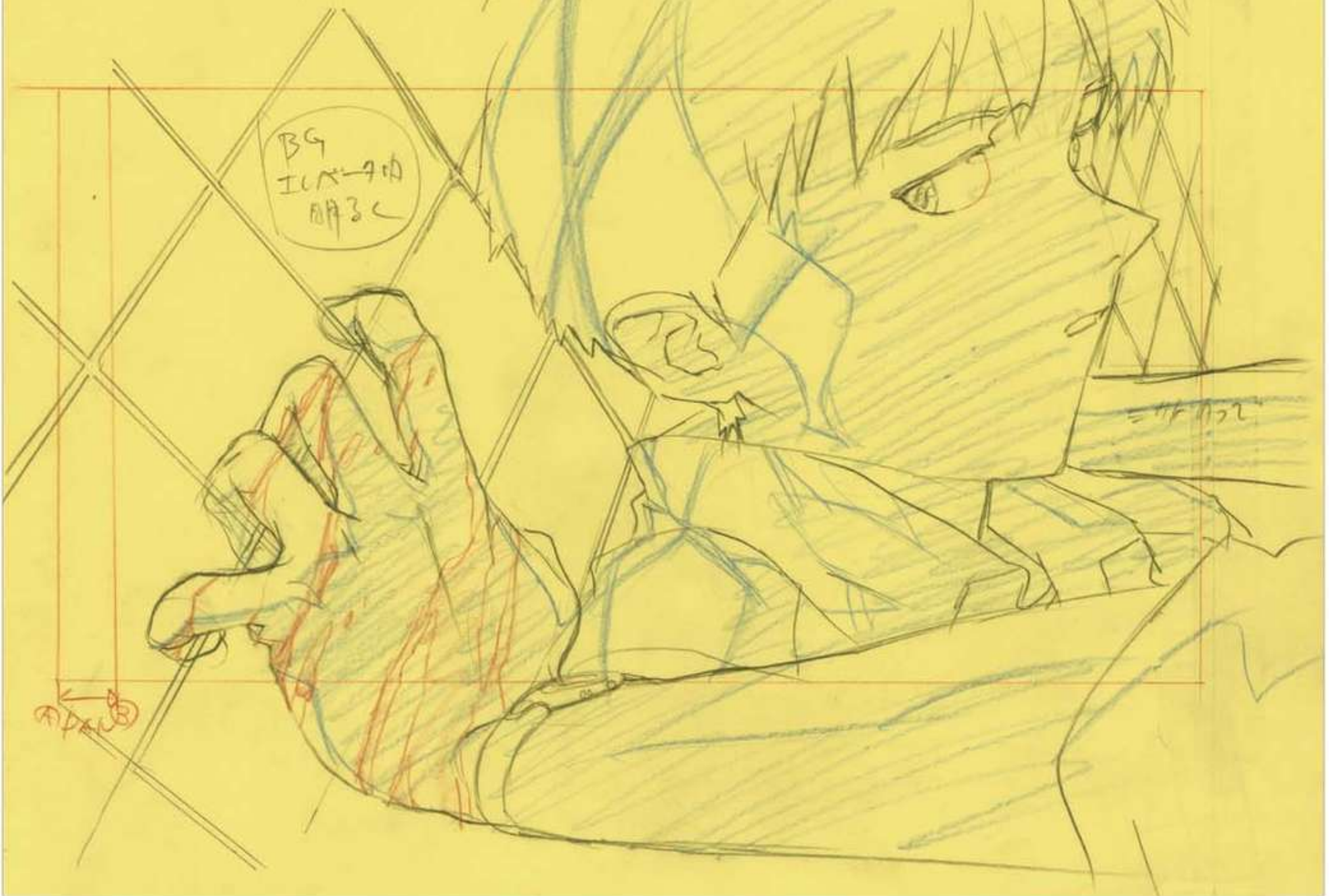

43  
42

B-7) 眼看向左  
8







A7  
my



A0)



ey  
D02) 眉と眼  
C3 髪 R2  
M



53C  
お顔の影

C67



53C  
お顔の影





#25-新 429  
修正原画

ア  
A B  
①  
②  
③  
④  
⑤  
ア  
イ  
ウ  
エ  
オ  
カ  
キ  
ク  
ケ  
コ  
サ  
シ  
ス  
セ  
ソ  
タ  
チ  
ツ  
テ  
ト

#25-新 429  
タイムシート

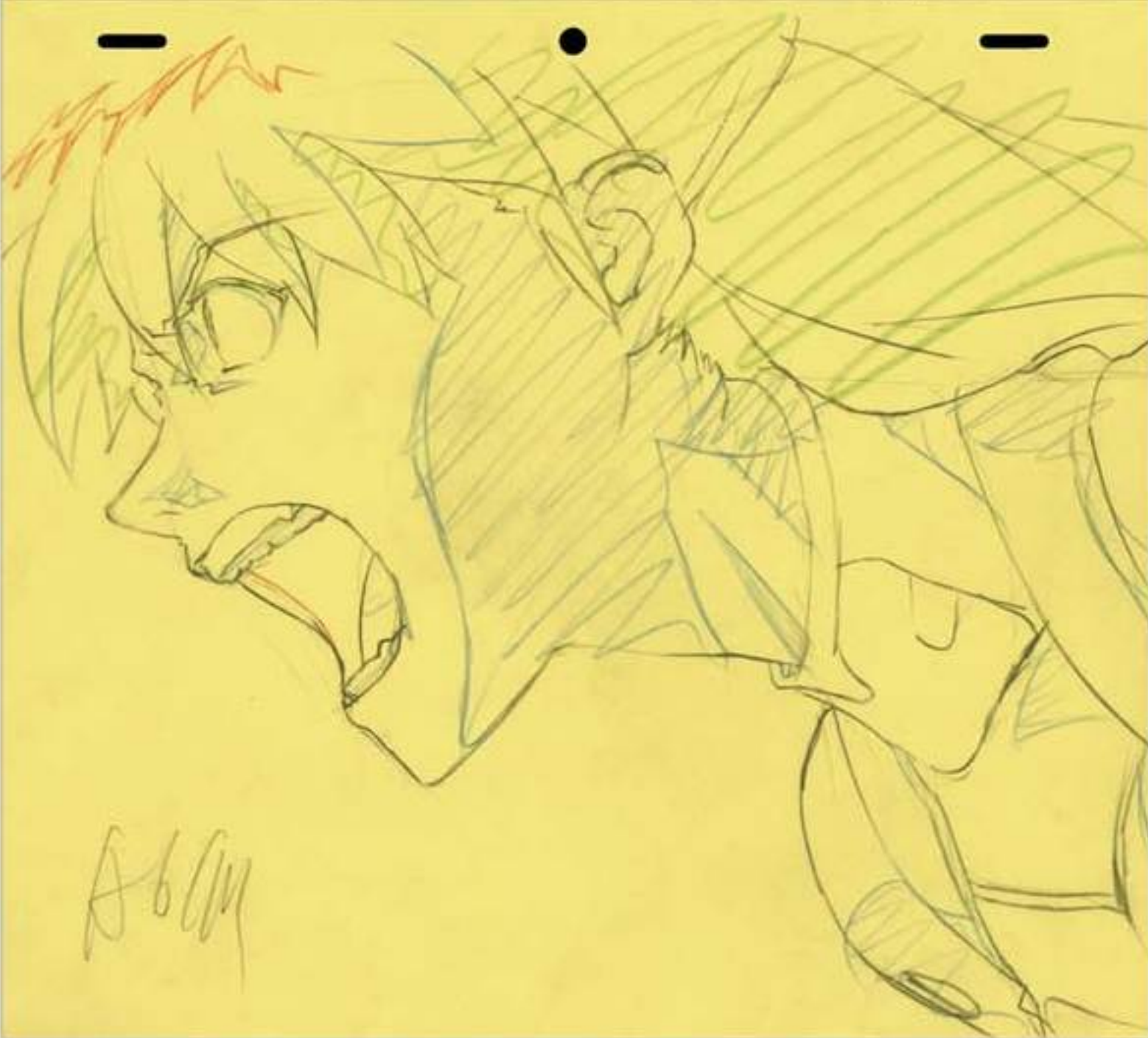









#25-新 473  
タイムシート



#25-新 500  
修正原画



#25-新 492, 497  
修正原画



A3



A1



A4



A2



A5



A6







A4



A5



A6

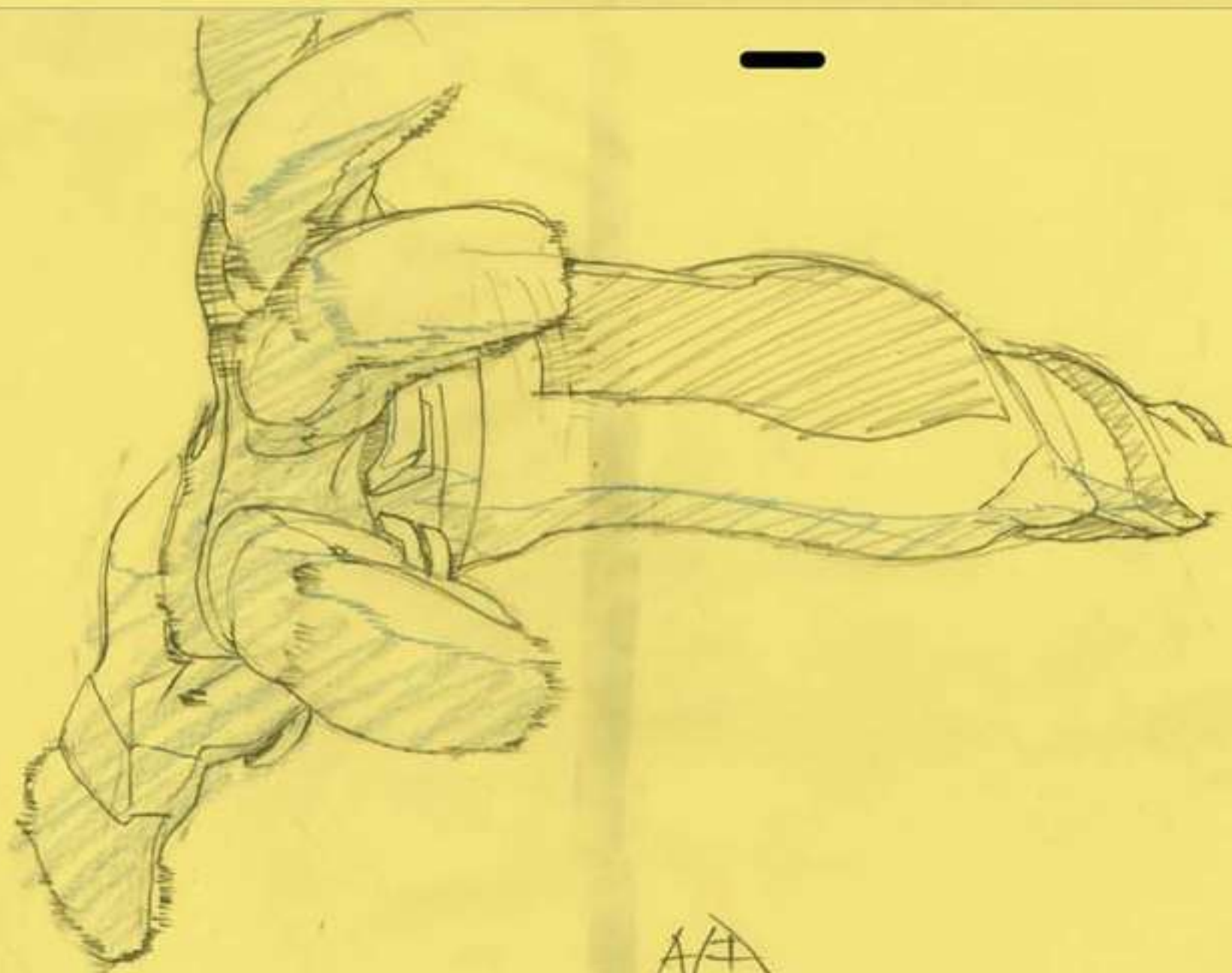

A4



#25-新 527  
修正原画



#25-新 527  
タイムシート

(47)

修正原画

#25-新 540, 543



表情 B-12 / 同+12

217 (19)



セル (14)  
217 (2)  
3/12

D0

#25-新 552, 567  
修正原画



A / 113  
伊吹 目尾  
B (1) 2



C-113

志











B1	13
1	14
2	15
3	16
4	17
5	18
6	19
7	20
8	21
9	22
10	23
11	24
12	25

#25-新 555  
タイムシート





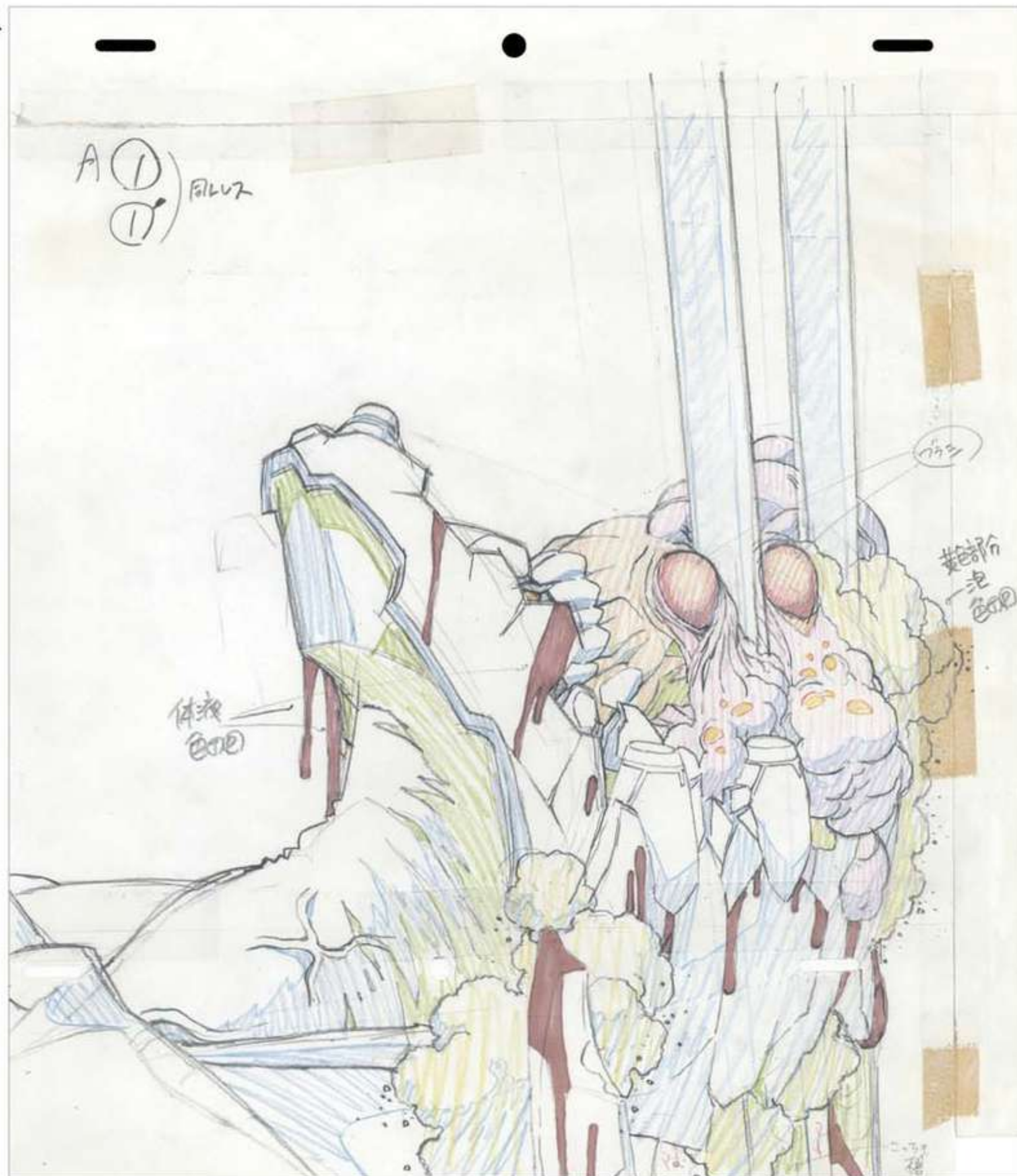



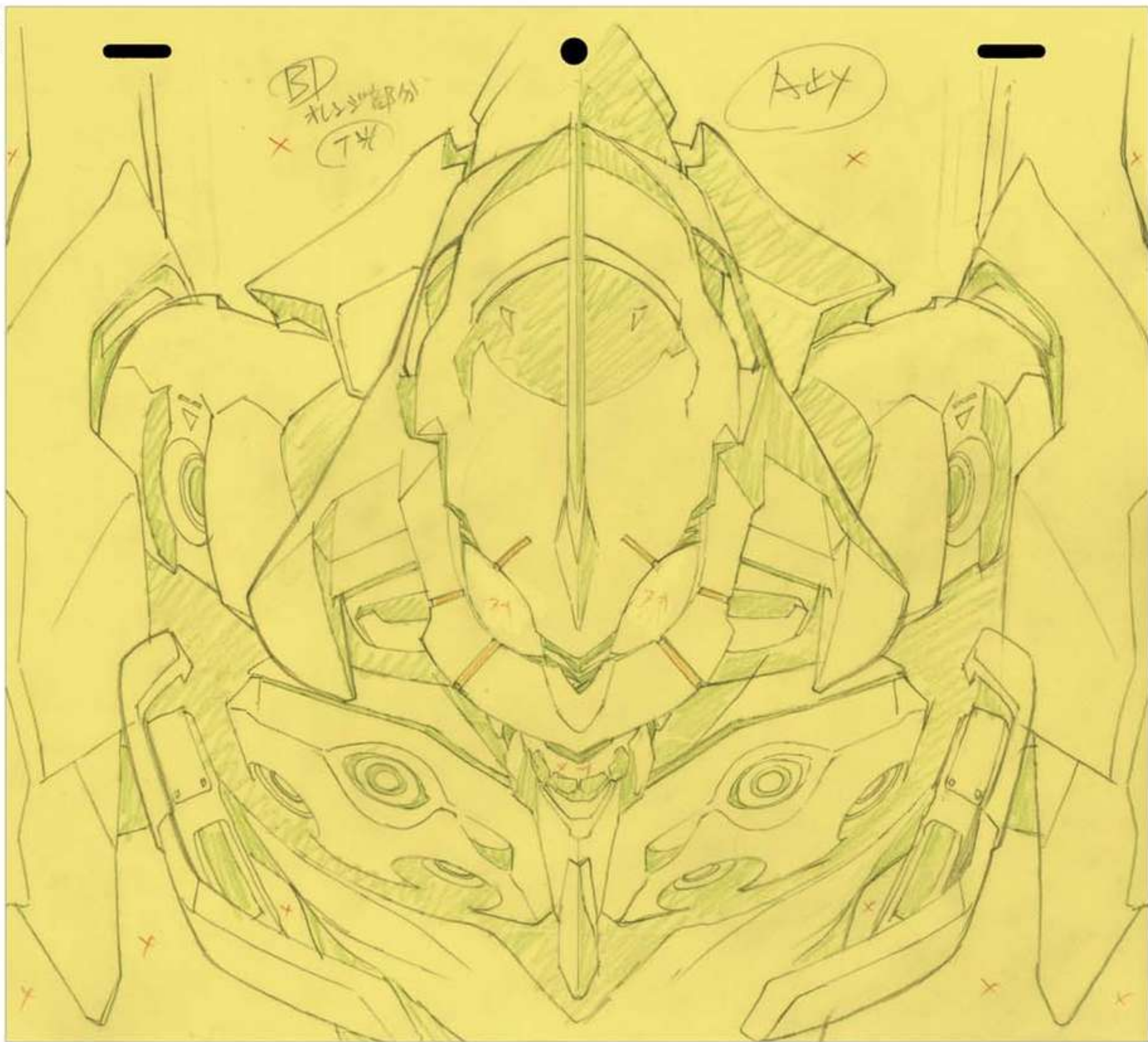





新世紀エヴァンゲリオン  
劇場版原画集  
上巻

Groundwork of EVANGELION



# Groundwork of EVANGELION The Movie 1

## 新世紀エヴァンゲリオン劇場版原画集 上巻

- この電子書籍は、2001年に刊行された『新世紀エヴァンゲリオン 劇場版原画集 上巻』を基に制作しました。
- ご覧になる端末機器の種類により、表示に差異が生じることがあります。あらかじめご了承ください。
- 本作品の全部または一部を著作権者ならびに株式会社カラー、株式会社グランドワークス：に無断で複製（コピー）、転載、公衆送信することを禁止します。改ざん、改変などの行為も禁止します。また、有償・無償にかかわらず本作品を第三者に譲渡することはできません。

---

監修：庵野秀明  
カバーイラスト：平松禎史

編集：「新世紀エヴァンゲリオン 劇場版原画集」編集部  
発行：株式会社カラー <https://www.khara.co.jp>  
販売：株式会社グランドワークス：  
東京都杉並区西荻北 3-30-11 パルファンビル 2F  
EVANGELION STORE <https://www.evastore.jp/>  
© カラー / EVA 製作委員会

禁 無断転載・複製



