



MANUAL





Table of Contents

Special note	3
Maintenance and Inspection	3
I. Inspection	3
1. Parts list	4
2. Half-Assembly type parts list	5
II. Machine view/size and power rating	6
III. Component description	6
IV. Assembly and disassembly	7
1. Assembly and disassembly for Disassembly type	7
2. Assembly and disassembly for Half-Assembly type	17
3. 【SET-UP Position & maintenance】	24
V. Adjustment and Inspection	24
1. Link adjustment	25
【 Cable link SET-UP 】	25
【 Link main board adjustment 】	26
2. Adjustment	27
【 SET-UP 1 】 SET-UP the coin entry price for each game	27
【 SET-UP 2 】 Additional tickets	28
【 SET-UP 3 】 Multiple of tickets	28
【 SET-UP 4 】 Game Time SET-UP	29
【 SET-UP 5 】 Basket motor AUTO test	30
【 SET-UP 6 】 Ball holder motor AUTO test	30
【 SET-UP 7 】 Reset the top score 250 or keep the record	30
【 SET-UP 8 】 SET-UP DEMO music (ON or OFF)	30
3. LED Monitor inspection	31
4. AUDIT	31
5. Error code	32
VI. How to play	33
1. There are total 4 Stages	33
2.2 play types available	33
VII. Screw and Nut list	34
VIII. Wires Layout	36
IX. Expeded view	37

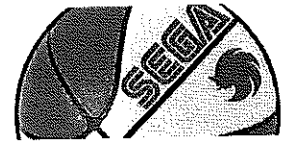
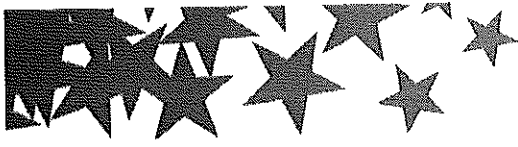

Special note

We want to thank you for choosing our Street basketball machine, and hope you read these instructions first to insure the security of the user before this product is used.

This Manual contains the characteristics, special notes, and a Simple breakdown of the product.

Maintenance and Inspection

- Keep the machine clean by using mild types of cleaners.
- Clean the machine regularly to maintain its appearance.
- The appliance must not be cleaned by a water jet.
- Treat acrylic with care by using Windex

ATTENTION!



※Machine position regulation

The power must be turned off before any movement.

The brake must be released, before the machine is moved.

Do not put the machine under the direct sunlight, it will damage the inside parts.







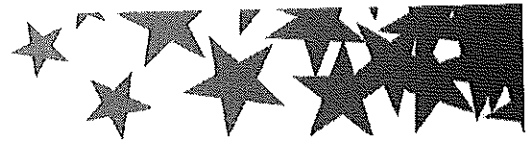

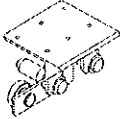
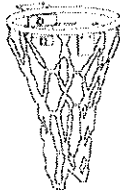
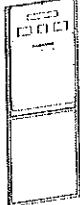
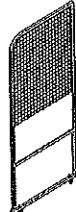

I. Inspection

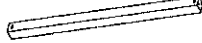
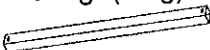
Before product use, please confirm the product content first, if anything is missing, please contact us right away.

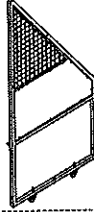
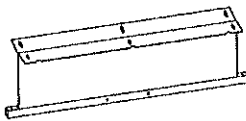
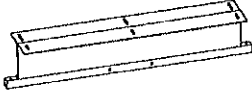
NO	Items	Specification	Total quantity
1	Chassis items	Packing	1 unit
2	Basketball	No.5 Basketball	10 unit
3	Key (702)	Maintenance door	1 pc
4	Key (436)	Cash box	1 pc
5	AC cable line		1 unit
6	Operation manual	A4	1 set

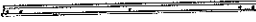
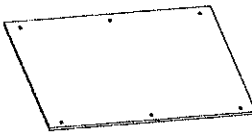
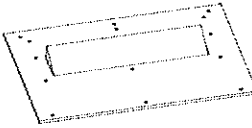
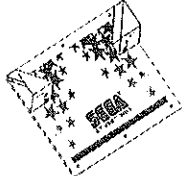
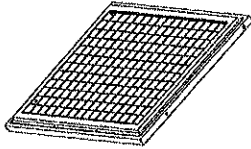
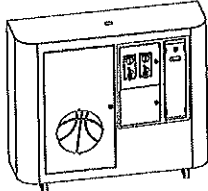
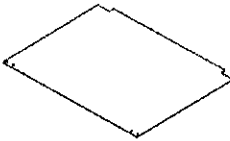

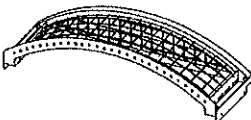
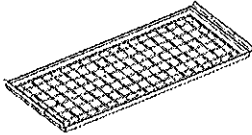
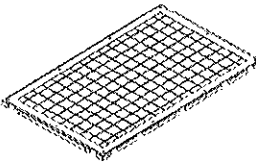



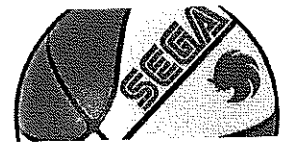

1.Parts list

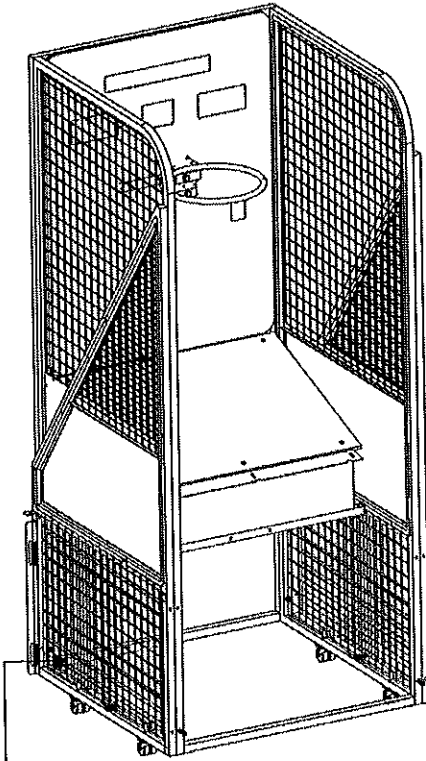
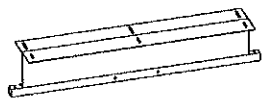
<p>1A Sensor for basket (WO-RNPW2)</p> 	<p>1B Basket kits</p> 	<p>2A Basket board</p> 	<p>2BR Back right net stander kit</p> 
<p>2BL Back left net stander kit</p> 	<p>2C 2 Front net stander bridge(short)</p>  <p>2E 2 Front net stander bridge(long)</p> 	<p>3A Front right net stander kit</p> 	<p>3B Front left net stander kit</p> 
<p>4A Base holder BF</p> 	<p>4B Base holder FB</p> 	<p>4C Base holder FF</p> 	<p>4D Base holder BB</p> 
<p>4E Base holder FF (Bottom)</p> 	<p>5A Wooden board A type</p> 	<p>5B Ball holder kit</p> 	<p>5C Ball guide kits</p> 
<p>6A Ball net holder kit</p> 	<p>6B Main part</p> 	<p>6C Block wooden board for motor</p> 	<p>6E Rabber pad</p> 
<p>Top cover</p> 	<p>Metal Shelf (optional)</p> 	<p>Lower Side Net (Frame Included)×4</p> 	<p>Basketball</p> 

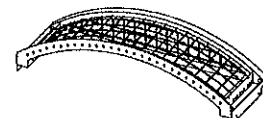
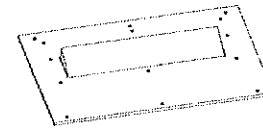

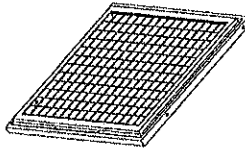
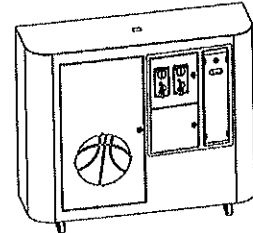
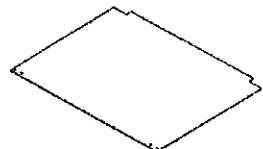
2.Half-Assembly type parts list

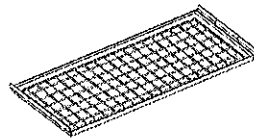
<p>Main frame</p>  <p>Lower Side Net(Frame Included)×4</p>	<p>4B Base holder FB</p> 	
	<p>4C Base holder FF</p> 	
	<p>Top cover</p> 	
	<p>5B Ball holder kit</p> 	
<p>5C Ball guide kits</p> 	<p>6A Ball net holder kit</p> 	<p>6B Main part</p> 
<p>6C Block wooden board for motor</p> 	<p>Basketball</p> 	<p>Metal Shelf (optional)</p> 



II. Machine view/size and power rating

Machine Dimensions : W1030×D2500×Top cover H2643mm
 Weight : 260 kg / 558.4 lbs (Accessories not Included)
 (Top cover 6.6kg · Metal Shelf 3.4kg · Lower Side Net 4.2kg×4)
 Voltage : AC110V~120V/AC220V~240V(50/60Hz) Use Electrical
 plug display as a glide Located behind the machine.
 Power Consumption : 200W
 Fuse : 3A
 Token size : φ22mm~27mm

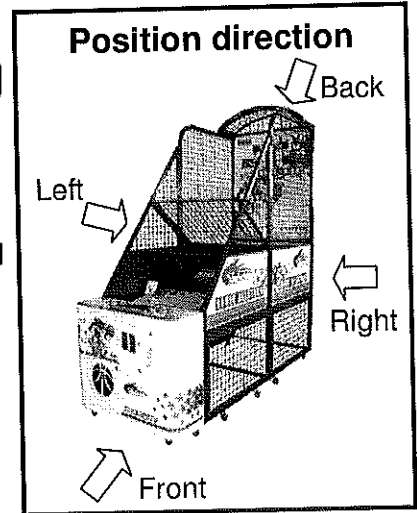

III. Component description

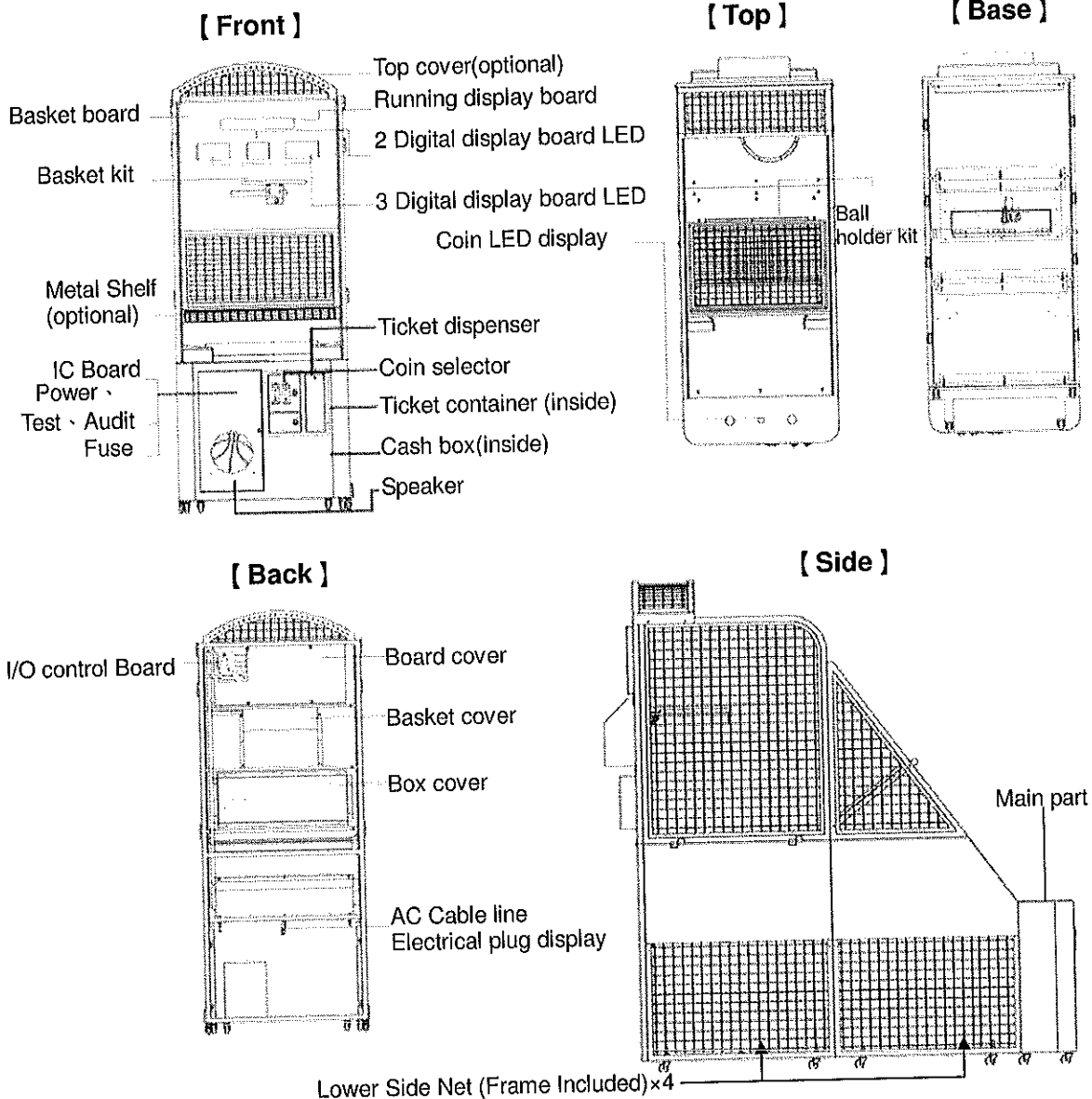

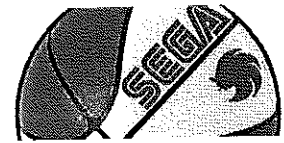

IV.Assembly and disassembly

1. Assembly and disassembly for Disassembly type

Step 1 :

1.Screw [Lower Side Net (optional)] on the basket board front.

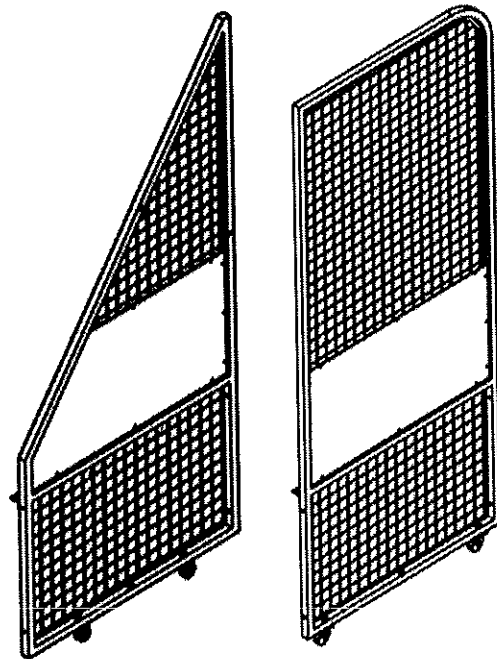
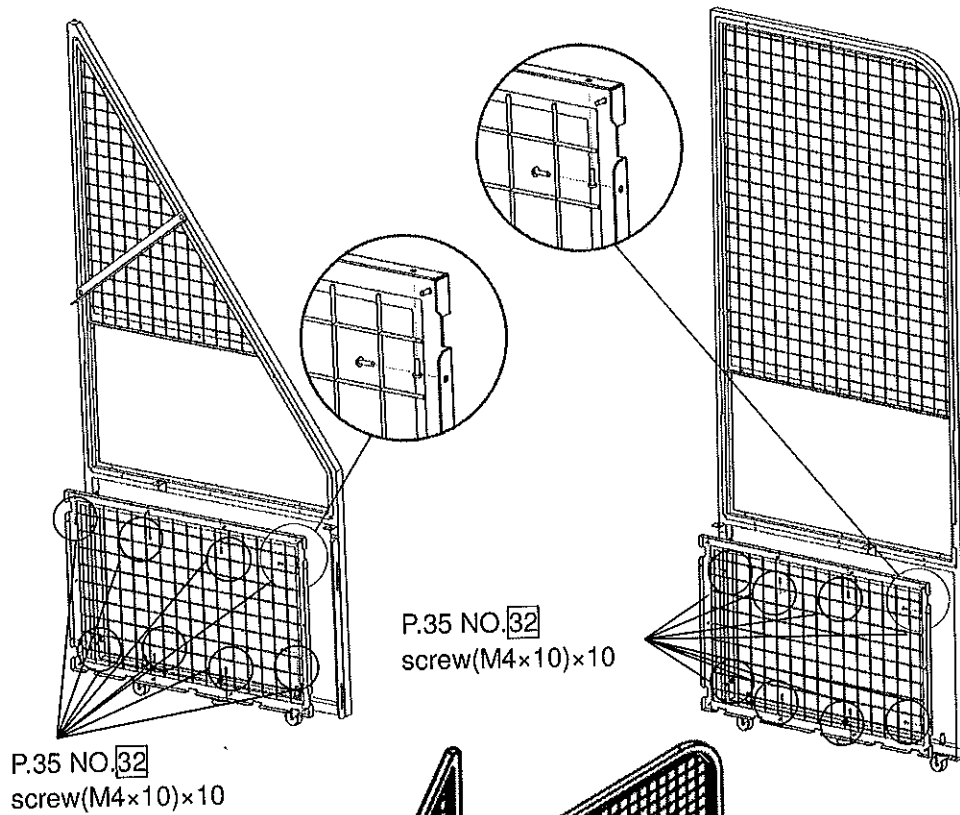

Assembly parts

- 2BR Back right net stander kit
- 2BL Back left net stander kit
- 3A Front right net stander kit
- 3B Front left net stander kit
- Lower Side Net(Frame Included)



Step 2 :

1.Screw [1B Basket kits] on the basket board front.

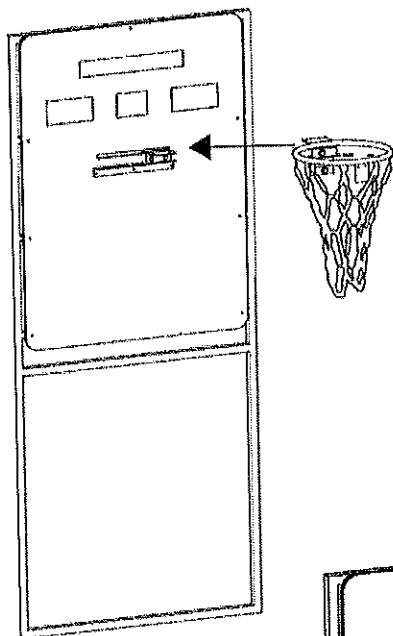

Assembly parts

- 1A Sensor for basket
- 1B Basket kits
- 2A Basket board

P.34 NO.13 screw(M5x15)x6

P.35 NO.21 nut(M5)x4

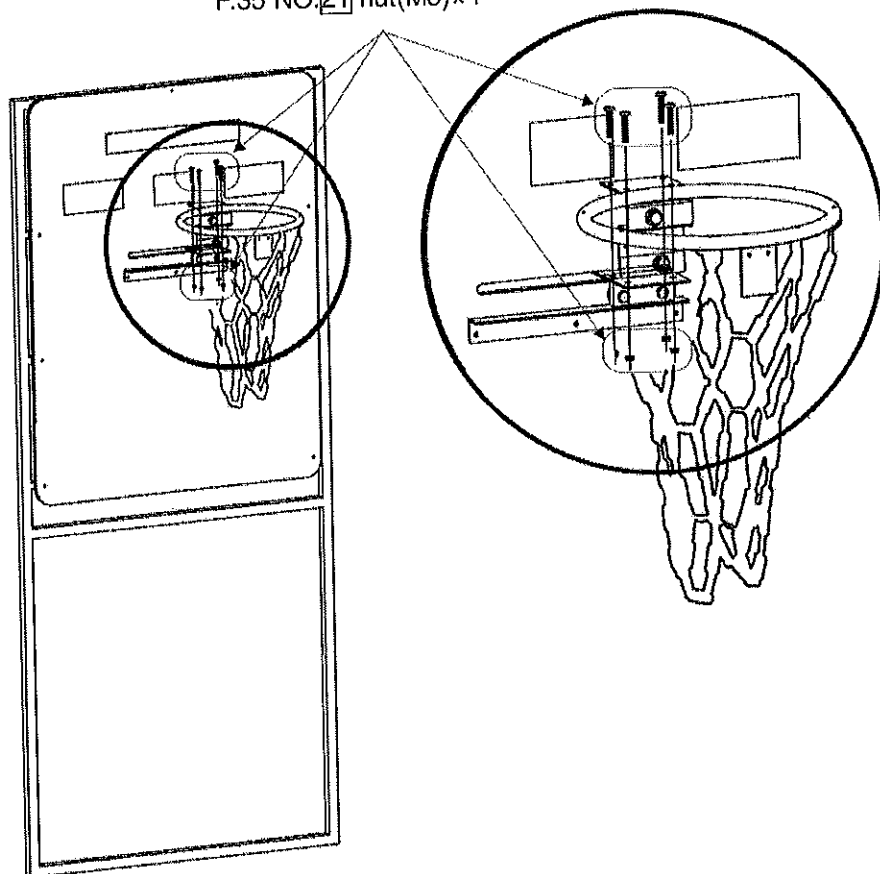

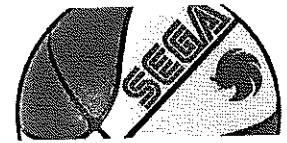

Step 3 :

1. Screw [2BR - 2BL Back left & right net stander kits] on basket board left and right.
2. Screw [2C Front net stander bridge(short)] on Back left & Right net stander kits.

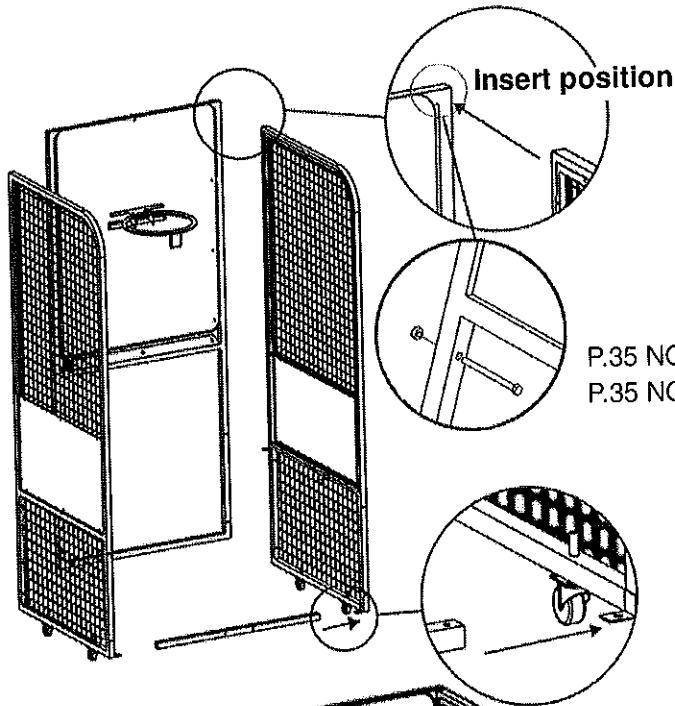

Assembly parts

- 2A Basket board
- 2BR Back right net stander kit
- 2BL Back left net stander kit
- 2C Front net stander bridge(short)

P.35 NO. **33** screw (M8×70)×4
P.35 NO. **19** nut (M8)×4

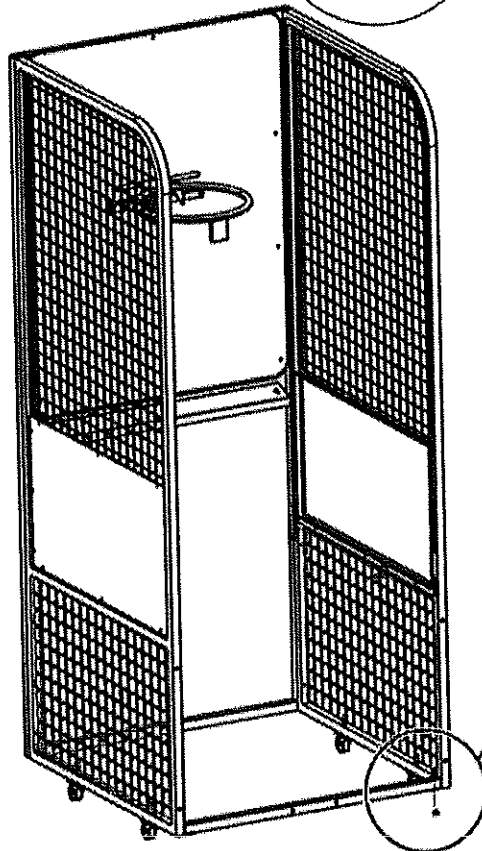

P.34 NO. **10** screw (M6×48)×2
P.35 NO. **20** nut (M6)×2

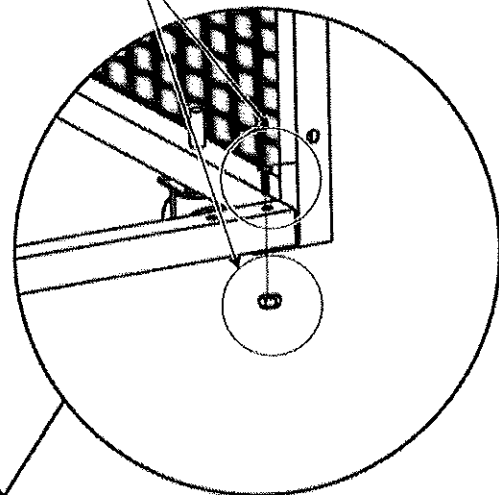

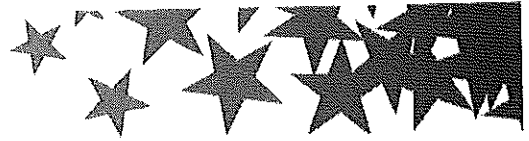

Step 4 :

Assemble [3A - 3B Front right & left net stander kit] on basket board left and right, connect with screw & fixed it as drawing.

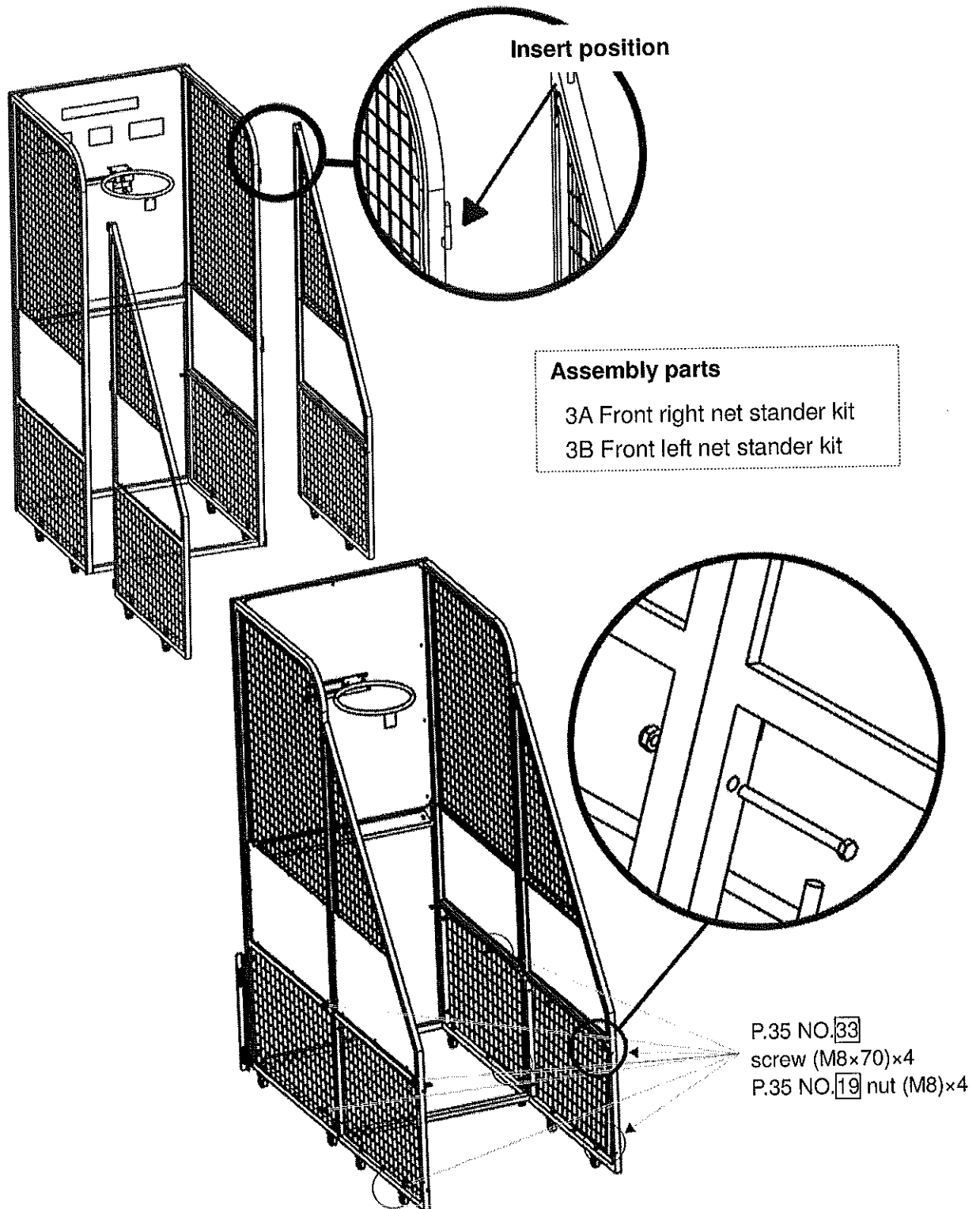

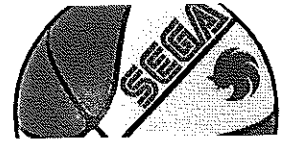
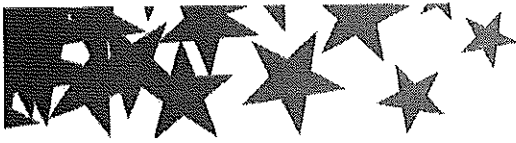

Step 5 :

Screw the [BF · FB · FF Base holders & Front net stander bridge(short)] step by step as drawing.

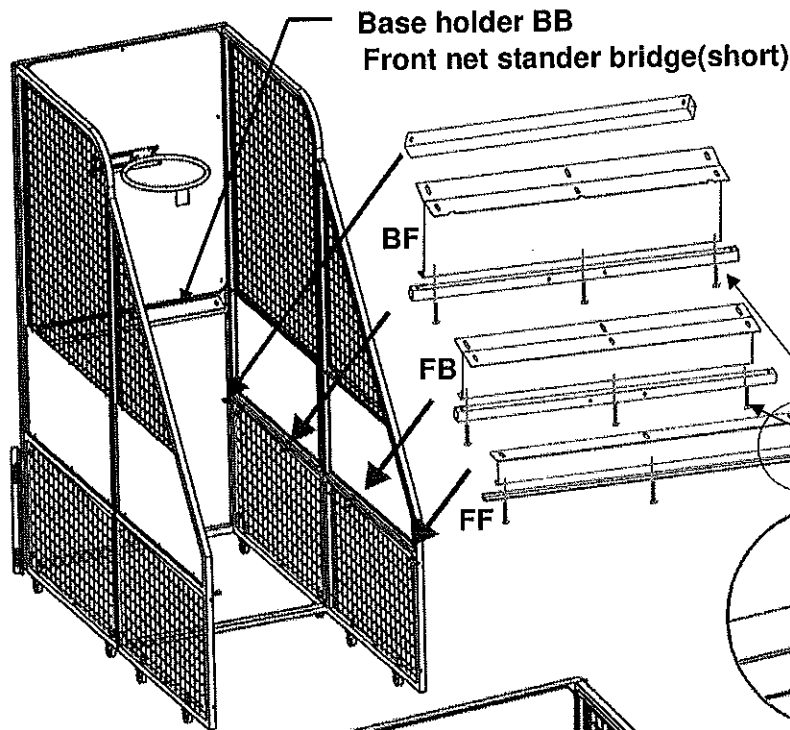

Assembly parts

- 2C Front net stander bridge(short)
- 2E 2 Front net stander bridge(long)
- 4A Base holder BF
- 4B Base holder FB
- 4C Base holder FF
- 4D Base holder BB
- 4E Base holder FF (Bottom)

- P.34 NO.10 screw (M6×48)×9
- P.35 NO.20 nut (M6)×9
- P.35 NO.30 washer(M6.5×13.5)×9

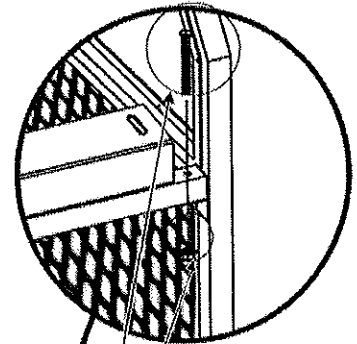
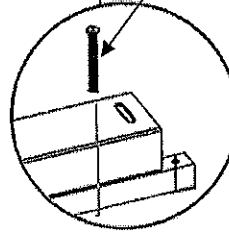

- P.34 NO.10 screw (M6×48)×6
- P.35 NO.20 nut (M6)×6

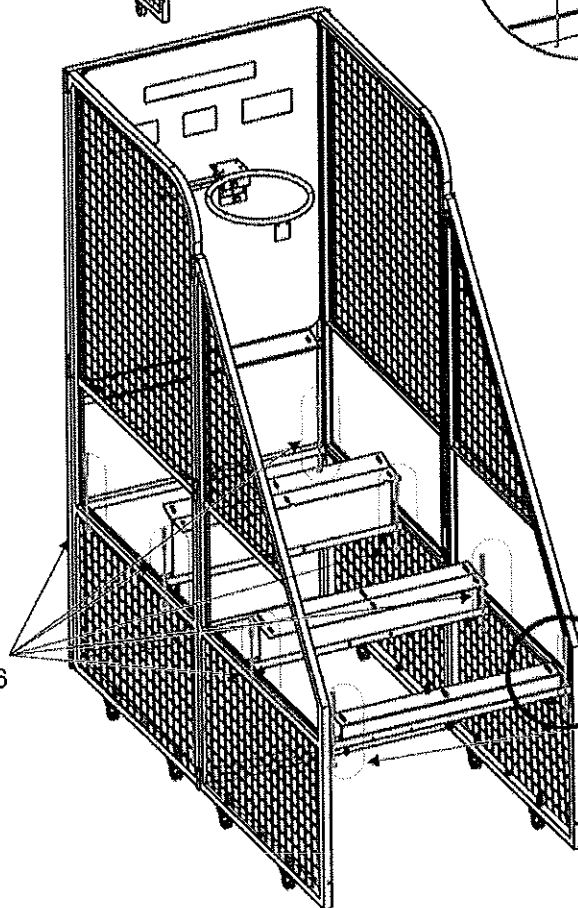

- P.34 NO.11 screw (M6×26)×2
- P.35 NO.20 nut (M6)×2

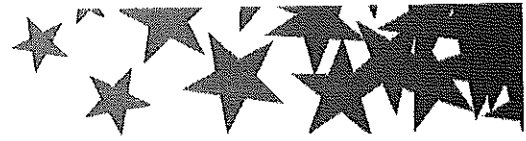

Step 6 :

Screw the [5A Wooden base A type · 5B Ball holder kit · 5C Ball guide kits] step by step as drawing.

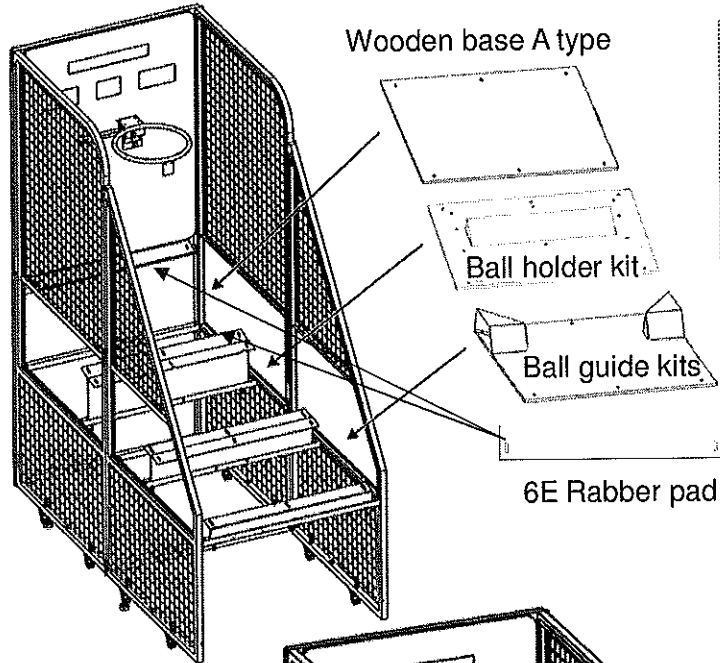

Assembly parts

- 5A Wooden board A type
- 5B Ball holder kit
- 5C Ball guide kits
- 6E Rubber pad

- P.34 NO.10 screw (M6×26) ×6
- P.35 NO.20 nut (M6) ×6
- P.35 NO.30 washer (M6.5×13.5) ×6

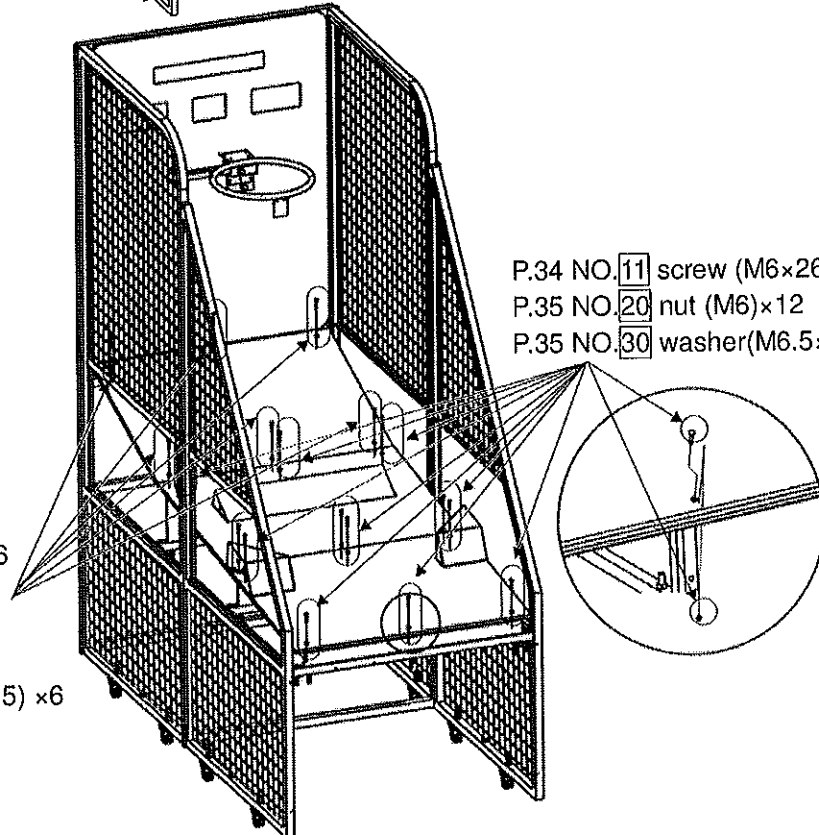

- P.34 NO.11 screw (M6×26)×12
- P.35 NO.20 nut (M6)×12
- P.35 NO.30 washer (M6.5×13.5) ×12

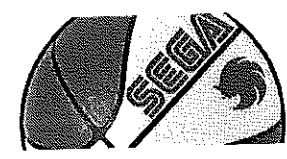
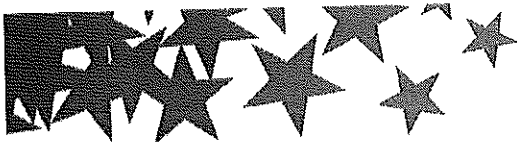

Step 7 :

1. Screw [6A Ball net holder kit] .
2. Screw [6B Main part] \ [Metal Shelf (optional)] .

Assembly parts :

- 6A Ball net holder kit
- 6B Main part
- Metal Shelf (optional)

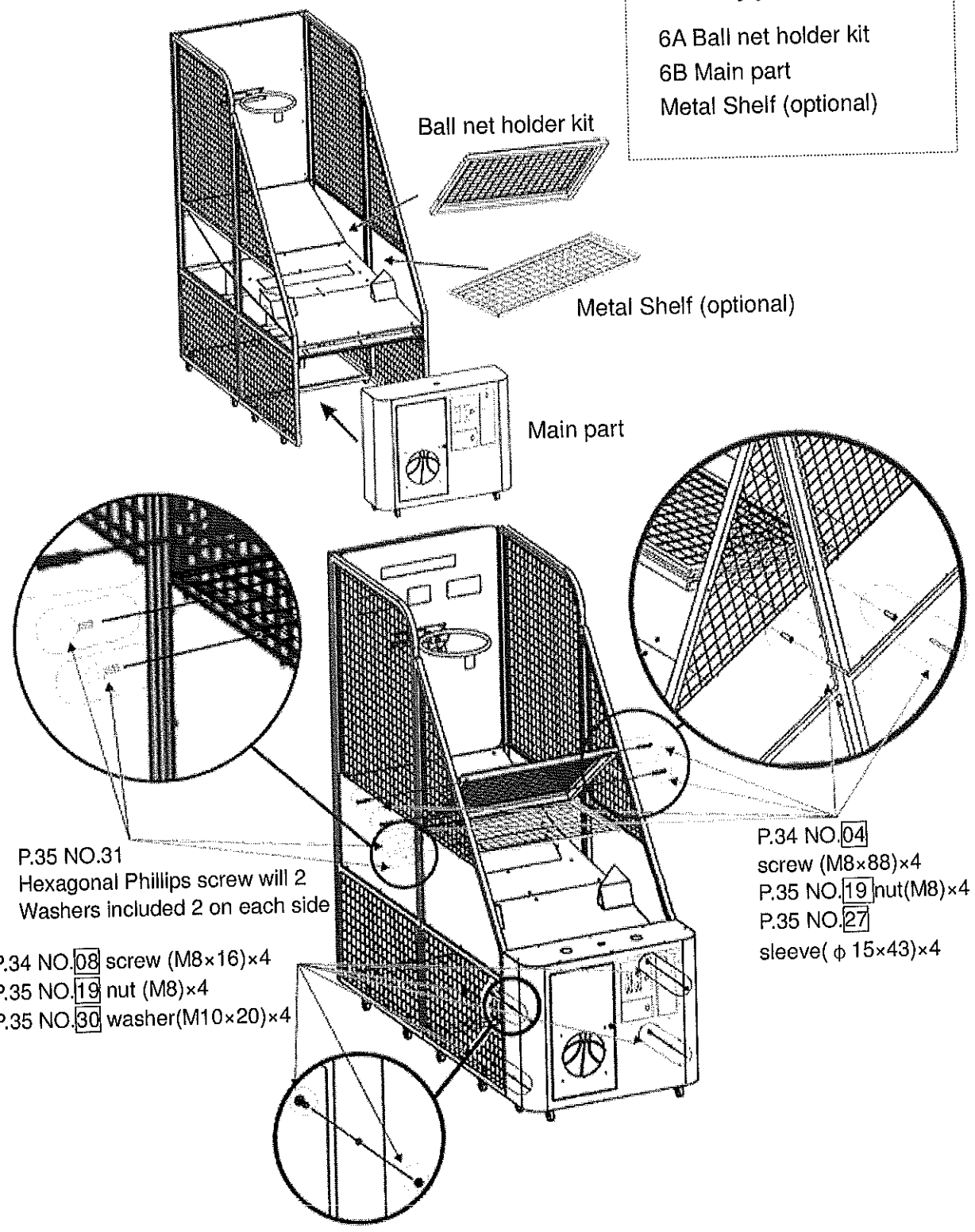

P.35 NO.31
Hexagonal Phillips screw will 2
Washers included 2 on each side

P.34 NO.08 screw (M8×16)×4
P.35 NO.19 nut (M8)×4
P.35 NO.30 washer(M10×20)×4

P.34 NO.04
screw (M8×88)×4
P.35 NO.19 nut(M8)×4
P.35 NO.27
sleeve(φ 15×43)×4

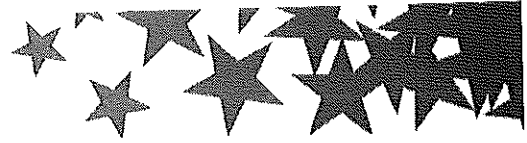

Step 8 :

1. Fix the 3 main cords as the following drawing.
2. Run the IC board plug and the ball holder kit plug located underneath the front of the ball net holder, through the hole in back of the main part.
3. Now connect plugs as shown in drawing.

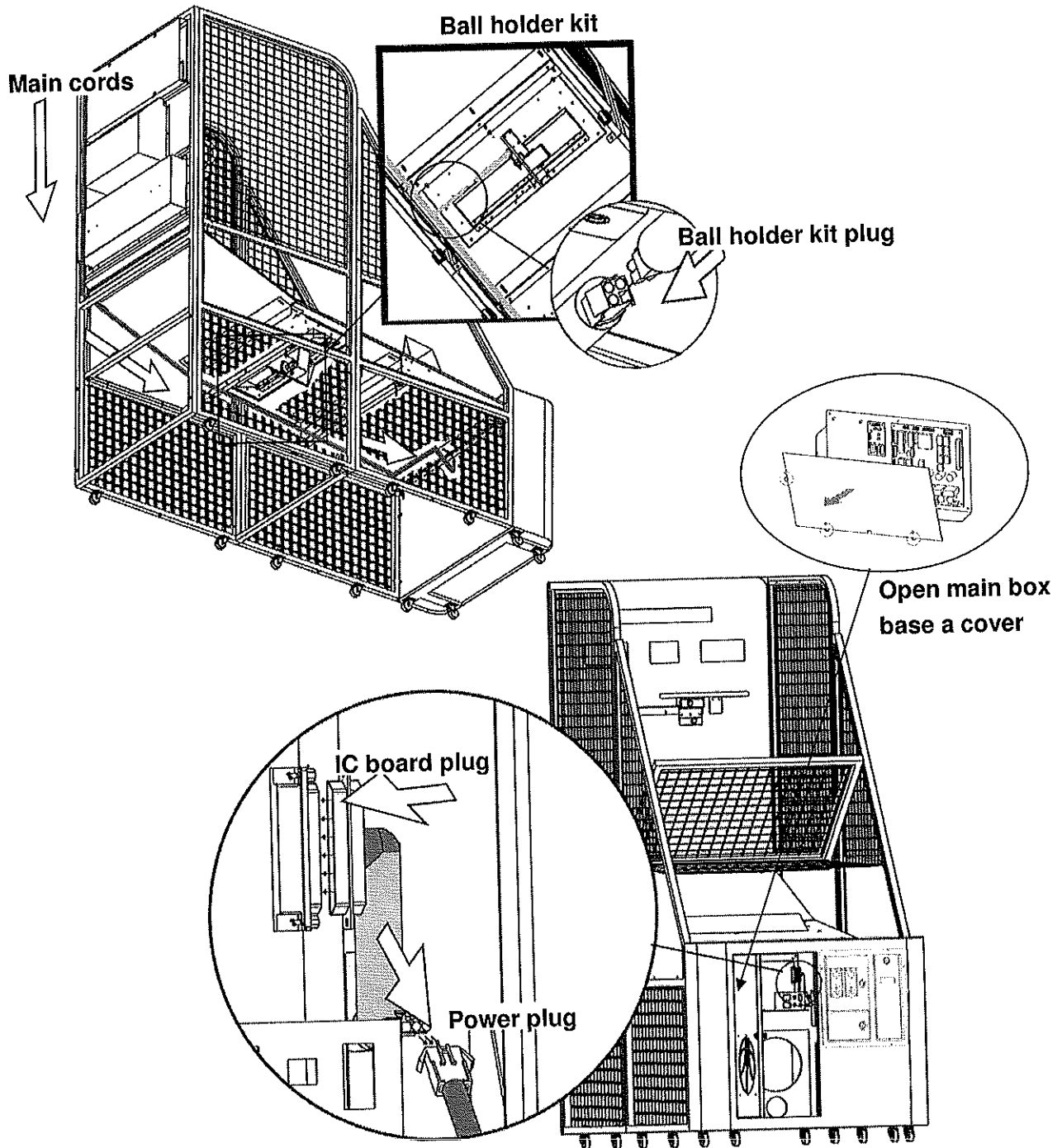

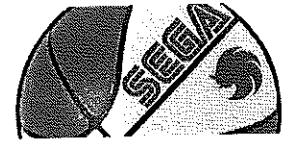

Step 9 :

Screw [Top cover(optional)] step by step as drawing.

Assembly parts

Top cover(optional)

Top cover(optional)

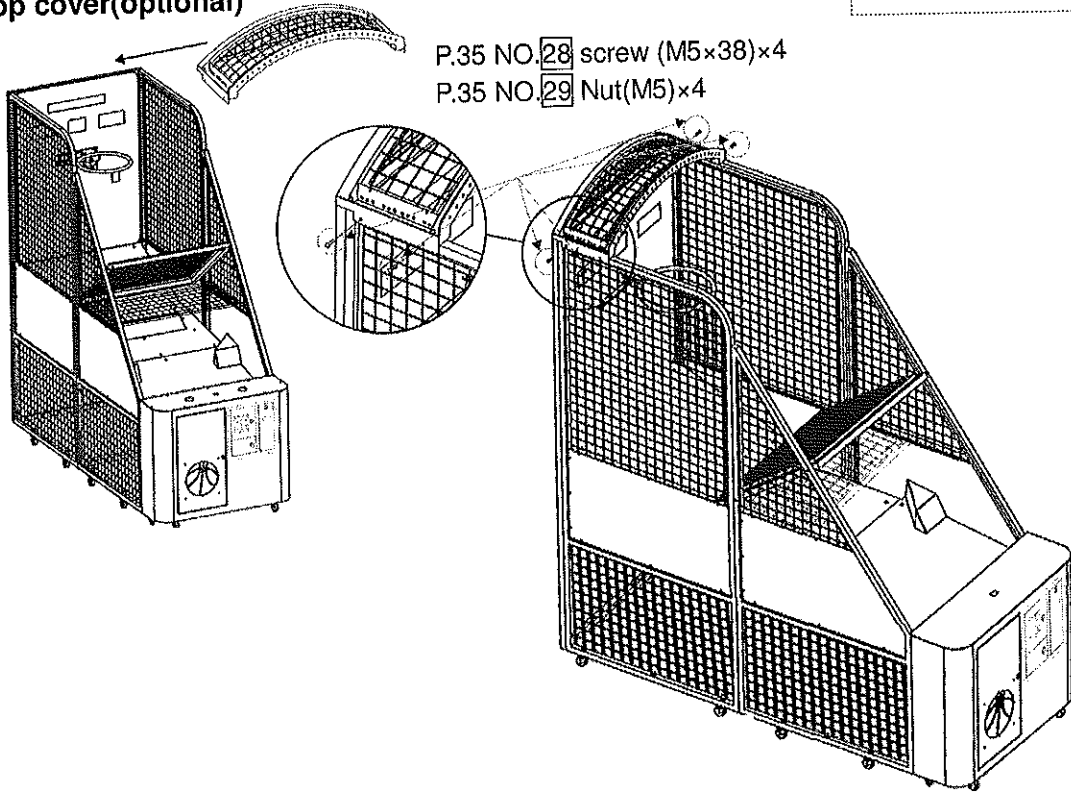

Step 10 :

1. connect the I/O control board with Top cover.
2. Now connect plugs as shown in drawing.

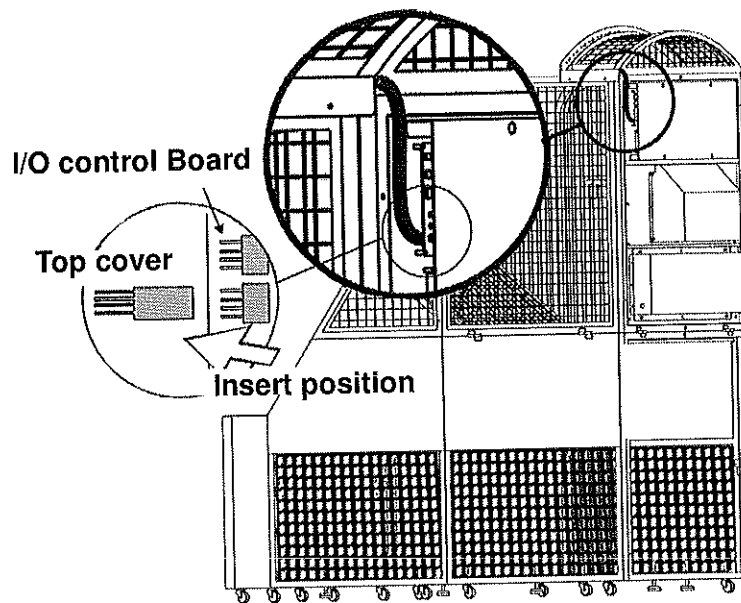



Step 11 :

Use screws fixed it then complete the assembly street basketball.

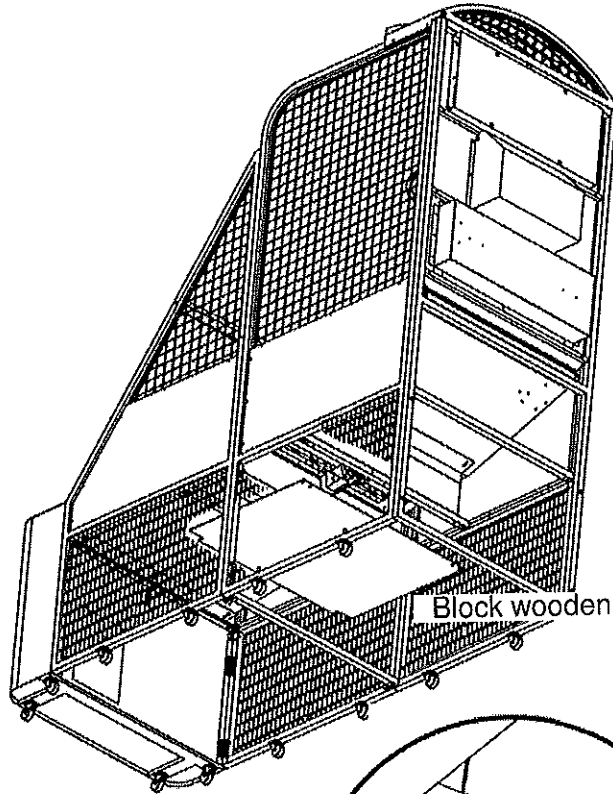

Assembly parts

6C Block wooden board
for motor

Block wooden board for motor

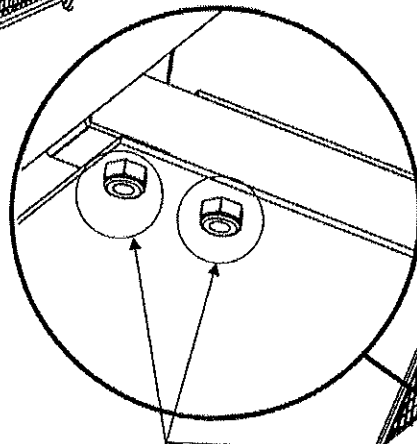

P.35 NO.20 nut(M6)×4

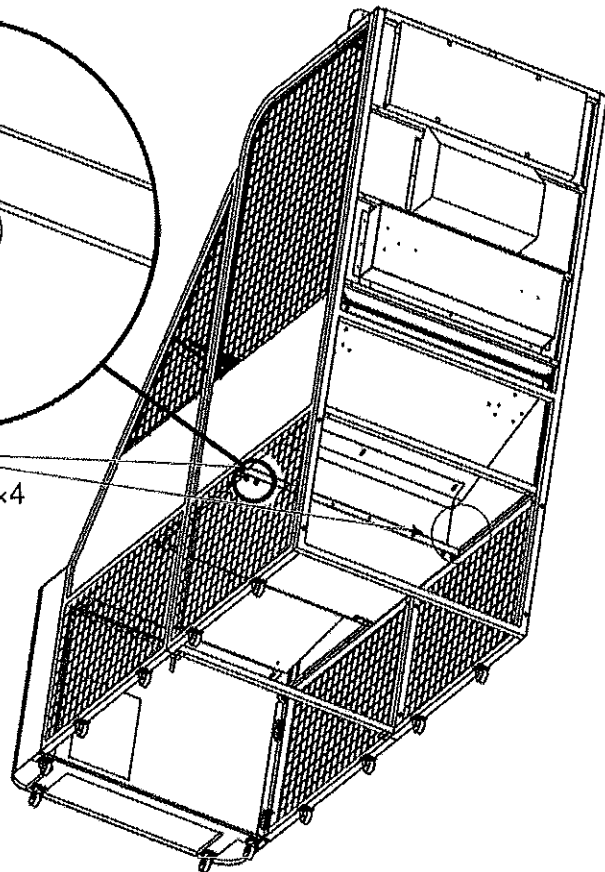

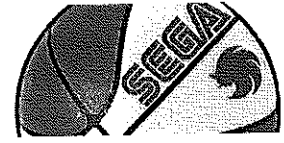

2. Assembly and disassembly for Half-Assembly type

Step 1 :

Turn the left and right frame 180° to the position as drawing picture . connect with screw & fixed it as drawing.

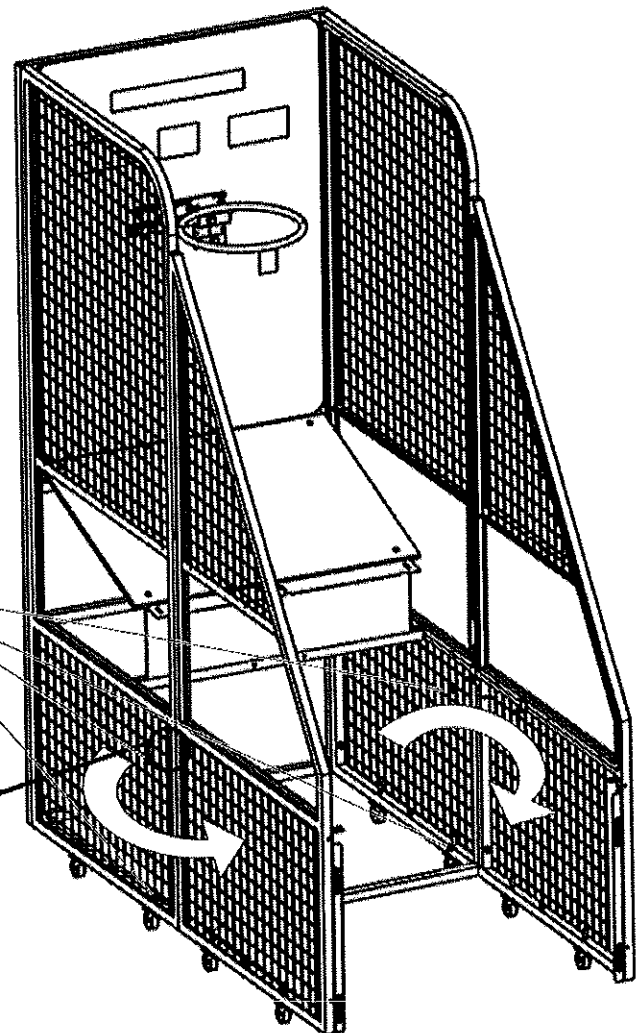
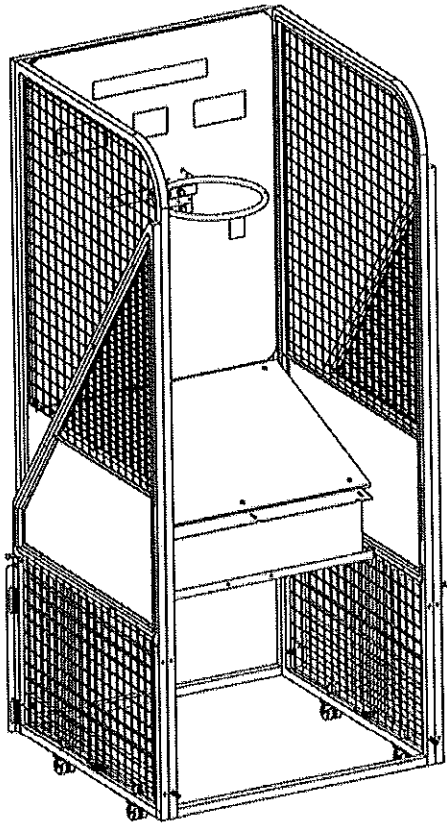

P.35 NO. **33**
screw (M8x70)x4
P.35 NO. **19** nut (M8)x4

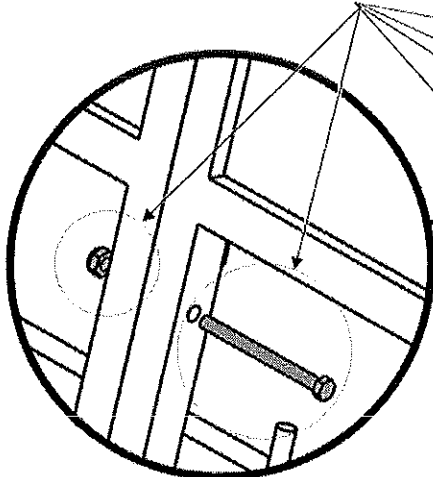

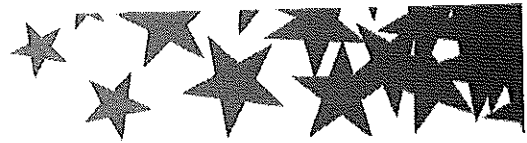

Step 2 :

Screw the base frame FB and base frame FF as drawing picture.

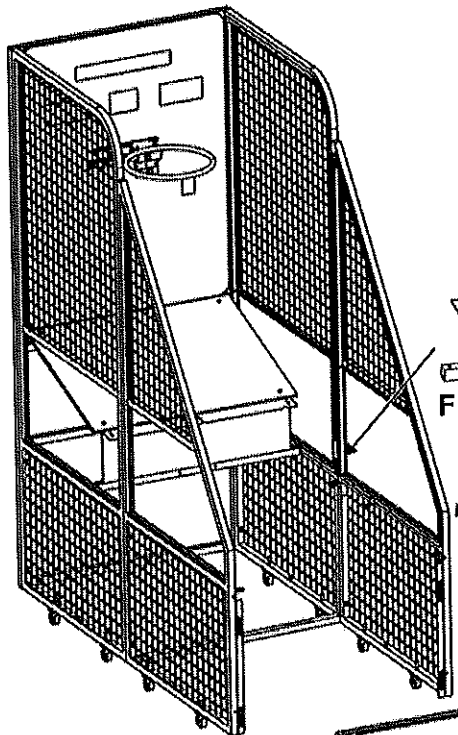

Assembly parts

- 4B Base holder FB
- 4C Base holder FF

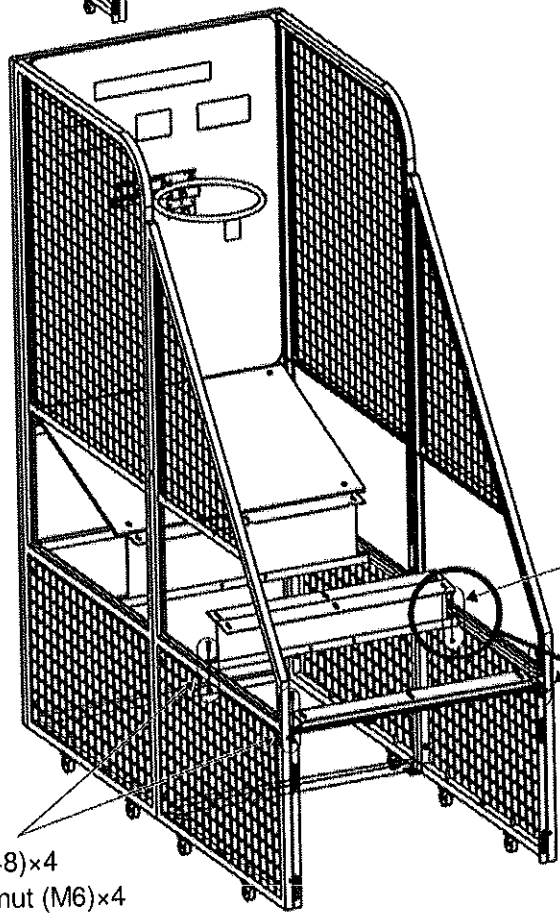
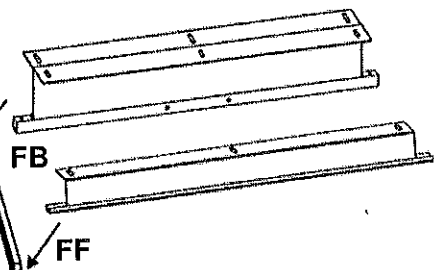

P.34 NO. 11
screw (M6×26)×2
P.35 NO. 20 nut (M6)×2

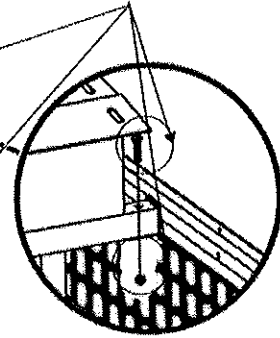

P.34 NO. 10
screw (M6×48)×4
P.35 NO. 20 nut (M6)×4

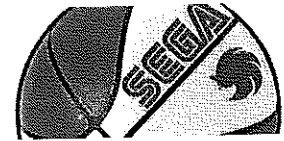
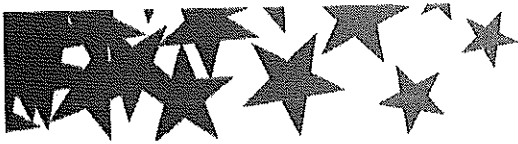

Step 3 :

Screw the 5B Ball holder kit and 5C Ball guide kits as drawing picture.

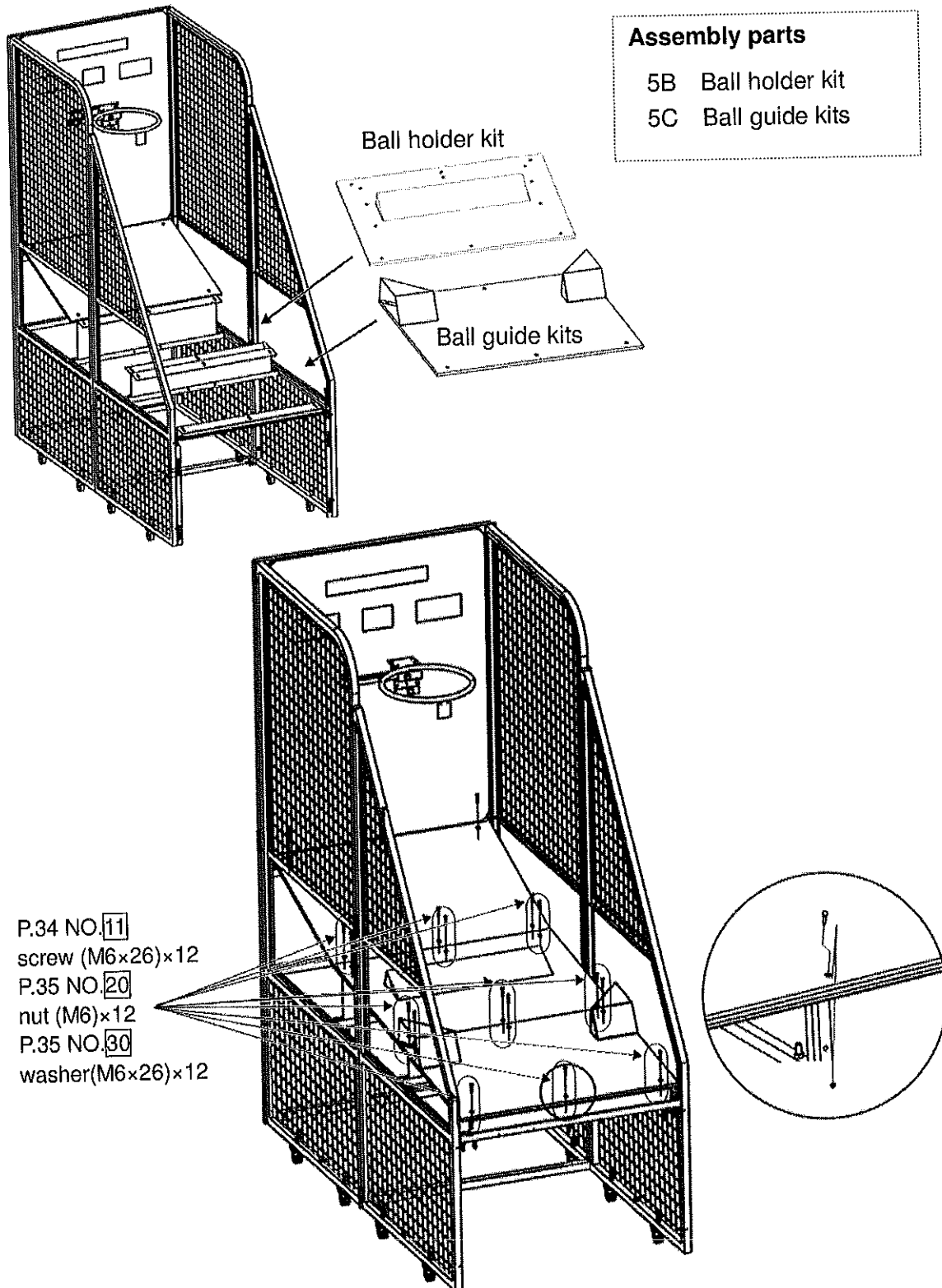

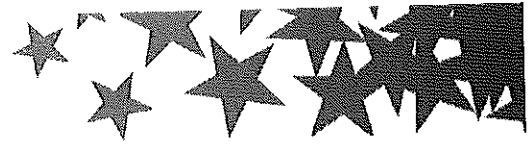

Step 4 :

1. Screw [6A Ball net holder kit] .
2. Screw [6B Main part] 、 [Metal Shelf (optional)] .

Assembly parts :

- 6A Ball net holder kit
- 6B Main part
- Metal Shelf (optional)

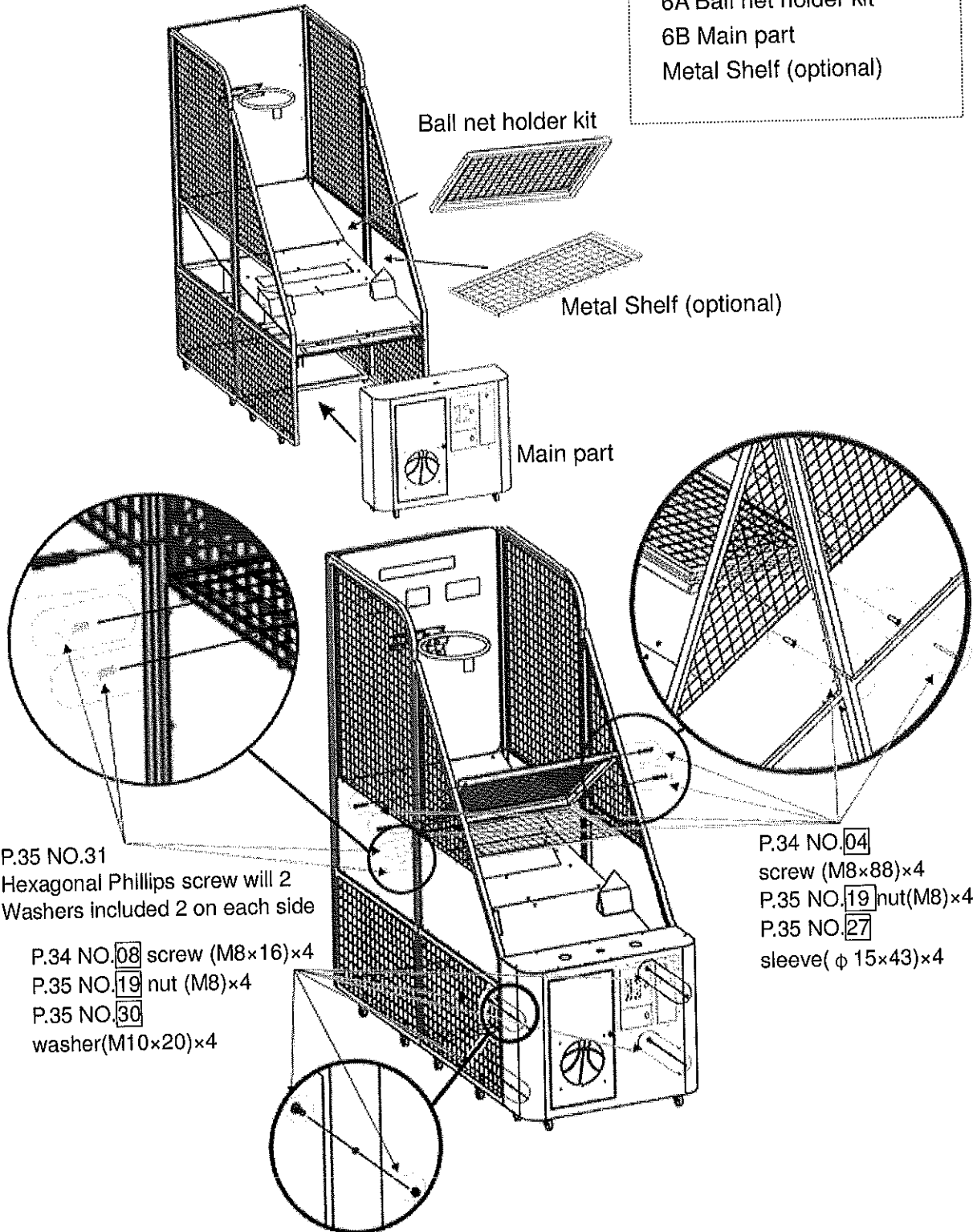

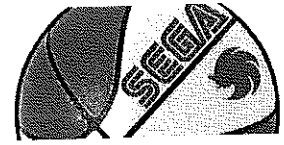

Step 5 :

1. Fix the 3 main cords as the following drawing.
2. Run the IC board plug and the ball holder kit plug located underneath the front of the ball net holder, through the hole in back of the main part.
3. Now connect plugs as shown in drawing.

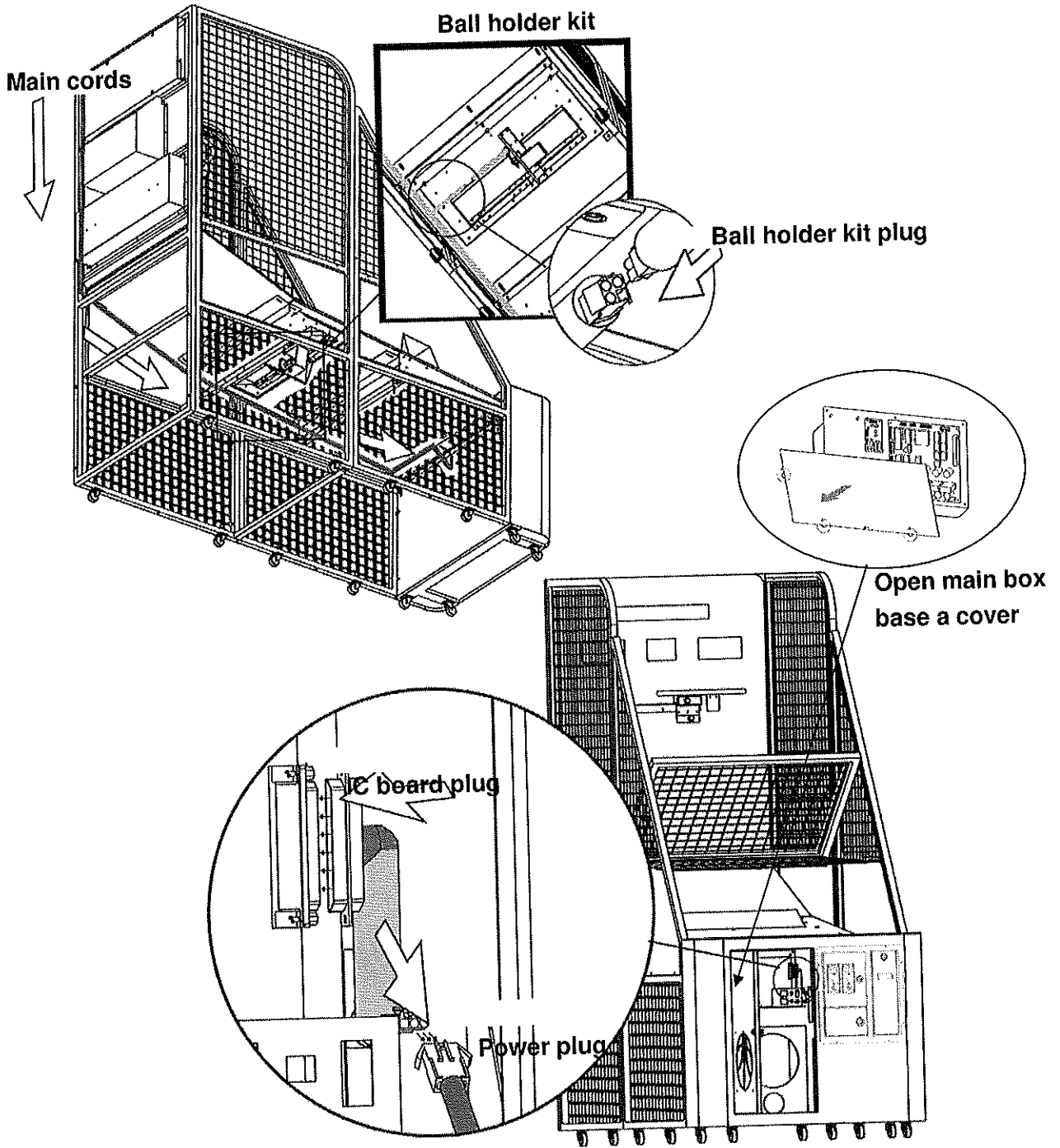



Step 6 :

Screw [Top cover(optional)] step by step as drawing.

Assembly parts

Top cover(optional)

Top cover(optional)

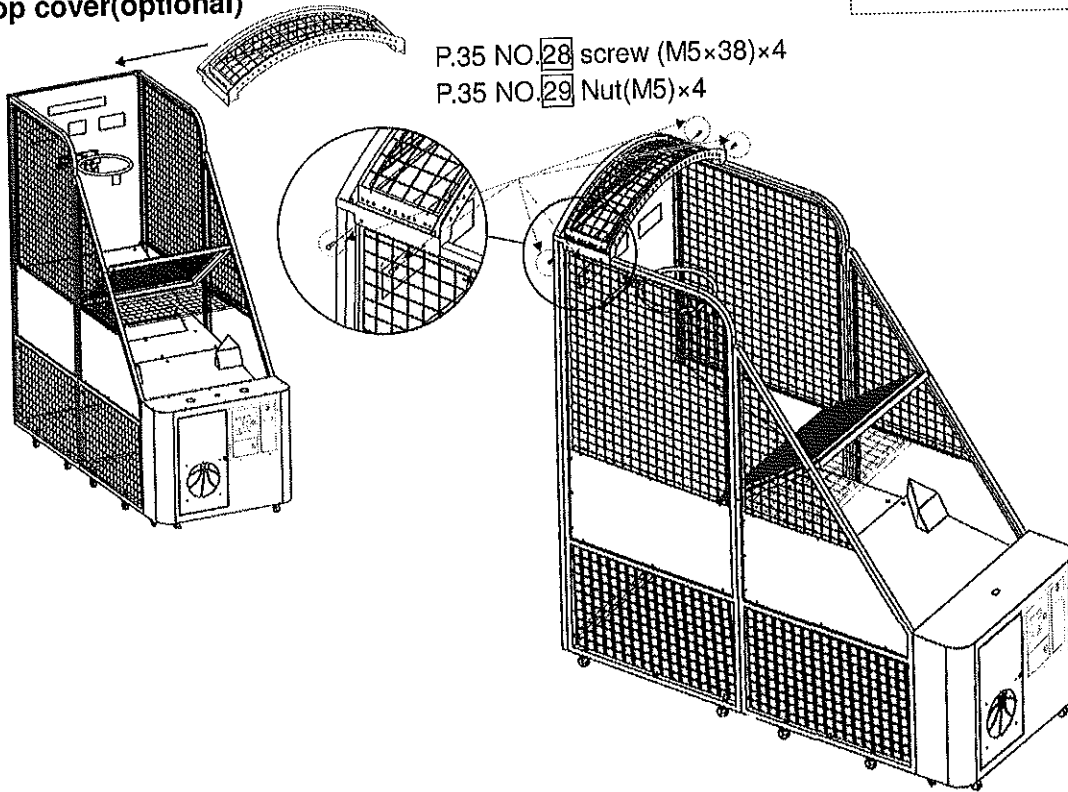

Step 7 :

- 1.connect the I/O control board with Top cover.
- 2.Now connect plugs as shown in drawing.

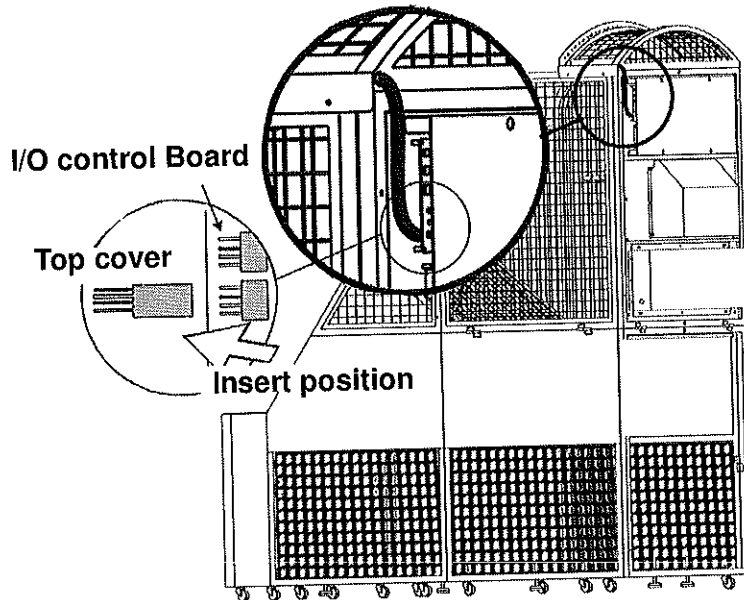

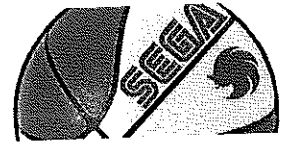

Step 8 :

Use screws fixed it then complete the assembly street basketball.

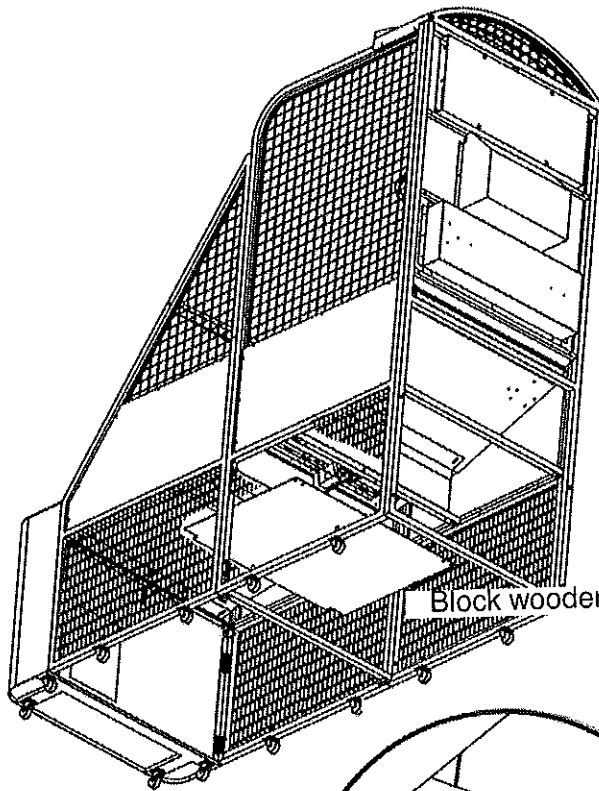

Assembly parts
6C Block wooden board
for motor

Block wooden board for motor

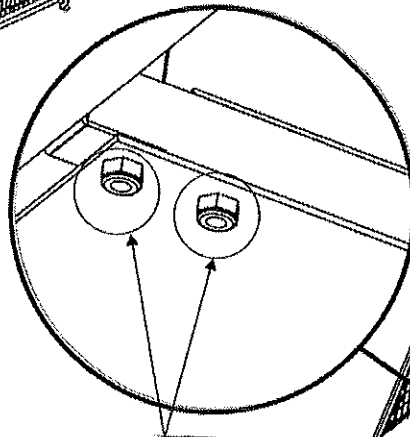

P.35 NO.20 nut(M6)×4

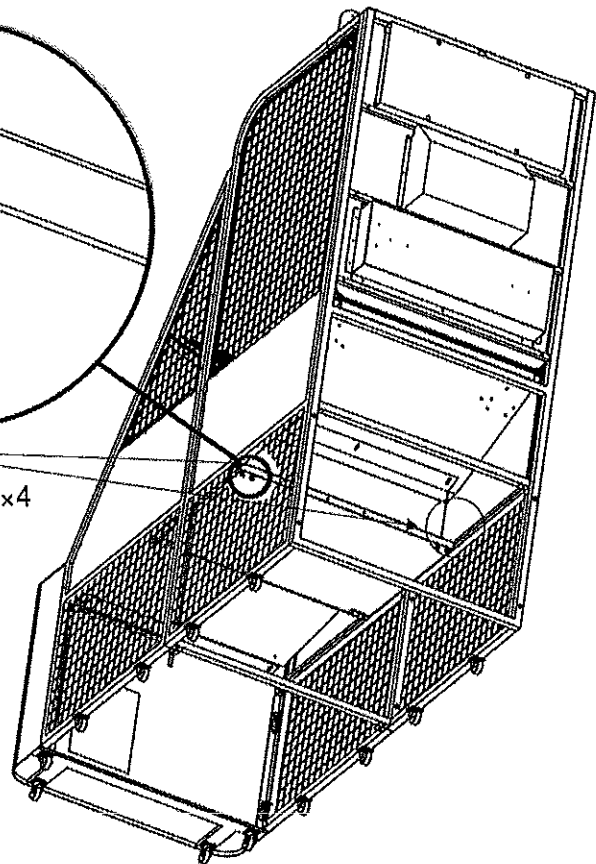

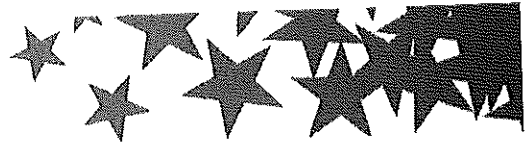

3. 【SET-UP Position & maintenance】

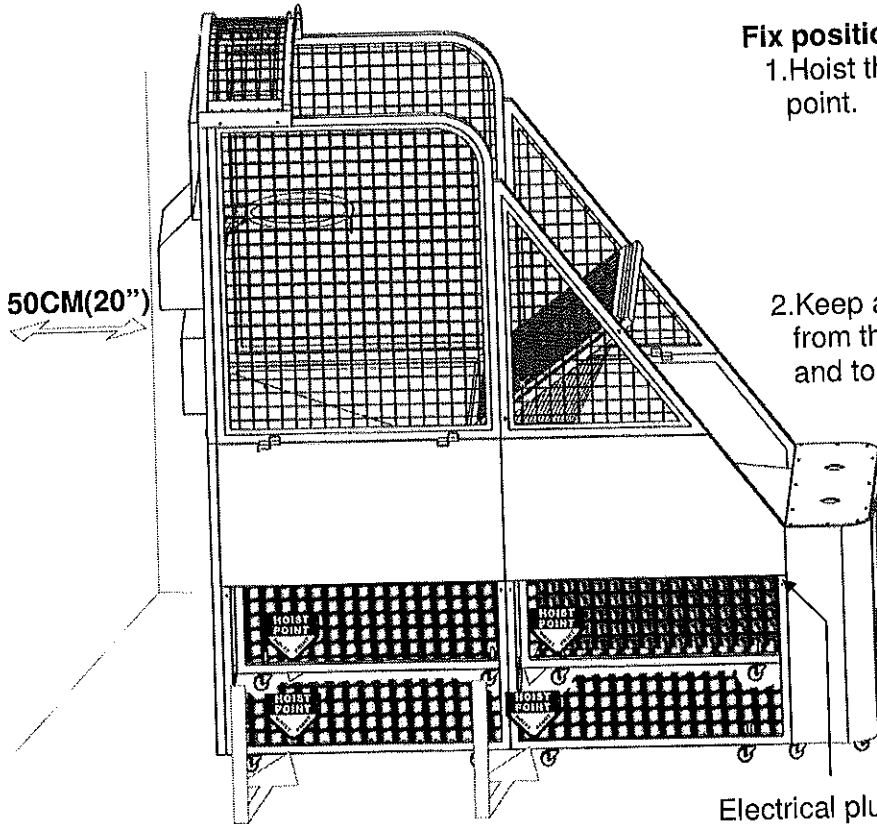

Fix position after assembly

1. Hoist the machine from the hoist point.



2. Keep at least 50cm(20") space from the back for maintenance and to avoid over heating.

Electrical plug display

Attention:

- ◎The power must be turned off before any movements.
- ◎Check the power rate before use AC110V~120V/AC220V~240V, Check Electrical plug display as a glide.

V.Adjustment and Inspection

You can find the audit system by opening the main part door.

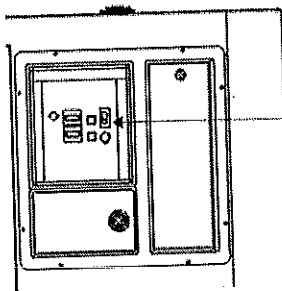

IC board includes power 、 fuse 、 audit and test functions

Please see 【1 Link adjustment】 for IC board function.

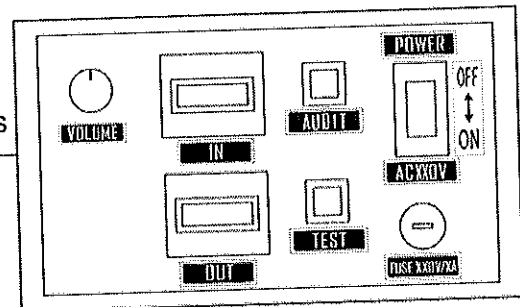

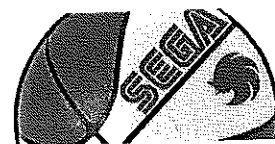

1.Link adjustment

[Cable link SET-UP]

The link set-up must follow DIP-SW-SEP-UP N0.1~15 machines.

Intermittent allowed, but repeat.

A . Link up to 15 machines

B . Only one main frame is needed.

C . Any game could be used as the main frame.

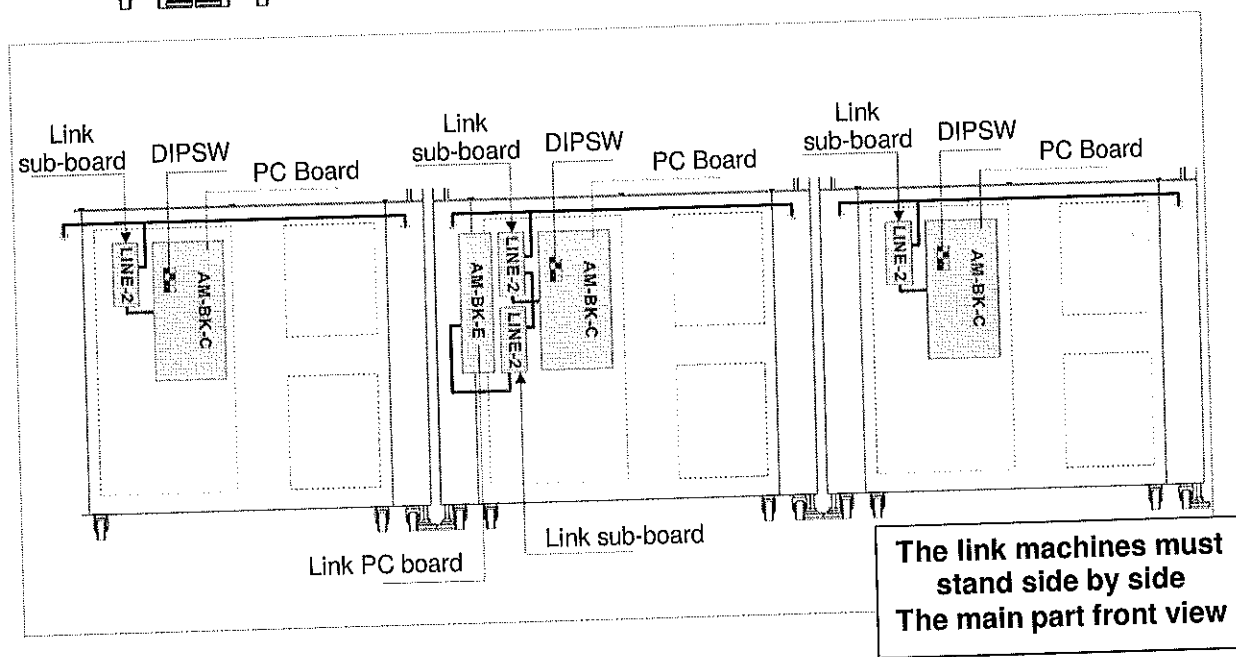
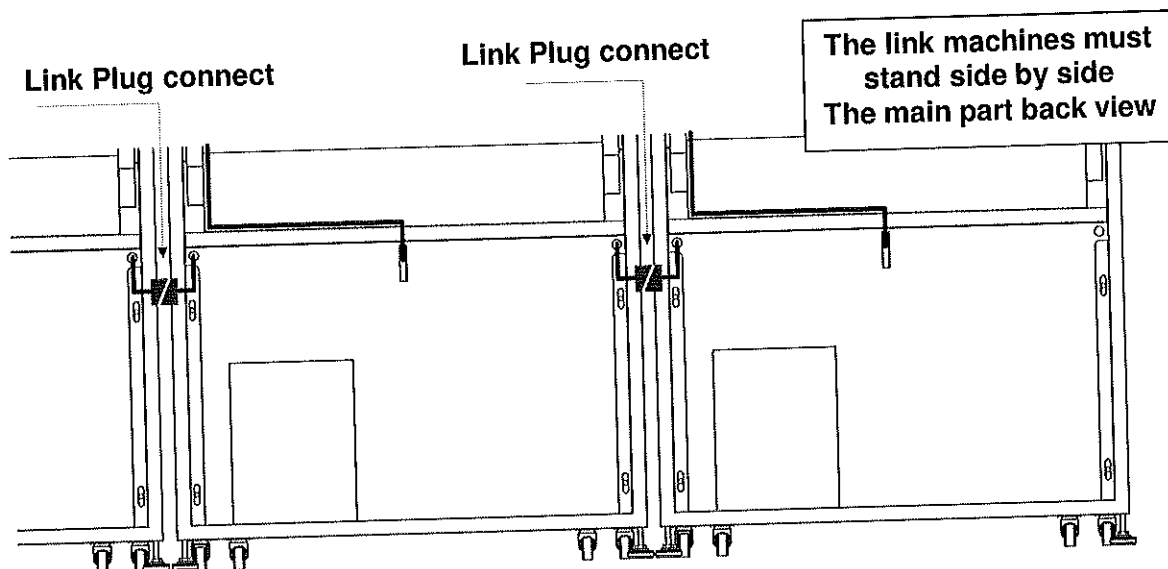



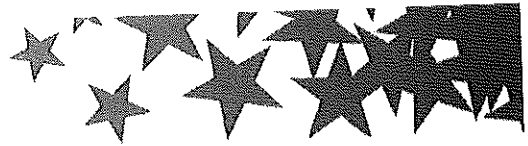

P.S. If two link machines-2 PCB are connected, the main control one DIP-SW must be set as OFF OFF OFF ON.

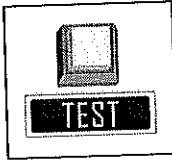

[Link main board adjustment]

Multi-function button :



1. Press and turn on the power, for 「TEST」 function.
2. In Standby mold  is 「SERVICE」 function, Press once means one coin, but No record.
3. In audit mold  is 「RESET」 function.
4. In ticket dispenser error mode, press  is 「Key out」 function.

Link DIP-SW adjustment :

SW4	SW3	SW2	SW1	
OFF	OFF	OFF	OFF	Single mode
OFF	OFF	OFF	ON	link 1 Unit
OFF	OFF	ON	OFF	link 2 Unit
OFF	OFF	ON	ON	link 3 Unit
OFF	ON	OFF	OFF	link 4 Unit
OFF	ON	OFF	ON	link 5 Unit
OFF	ON	ON	OFF	link 6 Unit
OFF	ON	ON	ON	link 7 Unit
ON	OFF	OFF	OFF	link 8 Unit
ON	OFF	OFF	ON	link 9 Unit
ON	OFF	ON	OFF	link 10 Unit
ON	OFF	ON	ON	link 11 Unit
ON	ON	OFF	OFF	link 12 Unit
ON	ON	OFF	ON	link 13 Unit
ON	ON	ON	OFF	link 14 Unit
ON	ON	ON	ON	link 15 Unit

Single mode starting display :

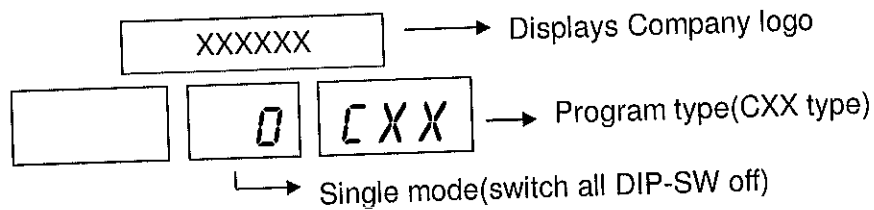

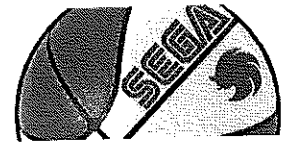

Link mode starting display :

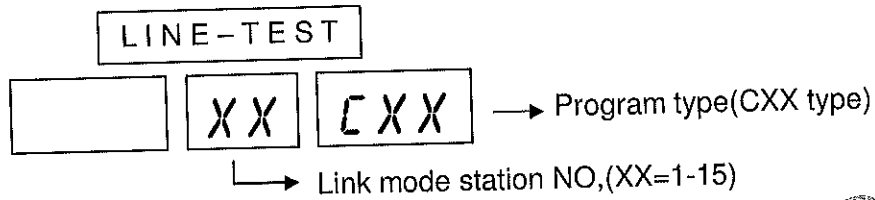

ATTENTION

When you turn on the main control machine, the other machines will link as set situation.

2.Adjustment

LINE-TEST after done the test can enter the set up.

Press and turn on the power, release the key after you hear the sound.

[SET-UP 1] SET-UP the coin entry price for each game

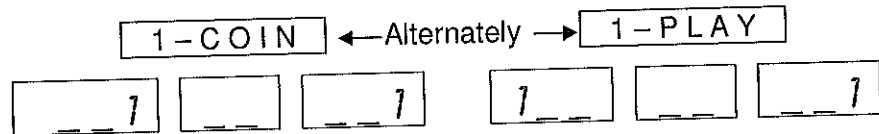

Press then release

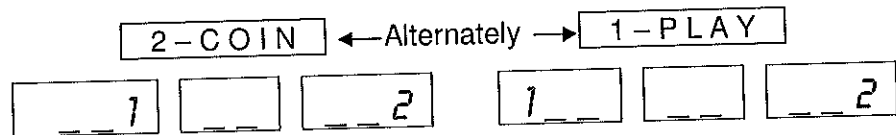

Press then release

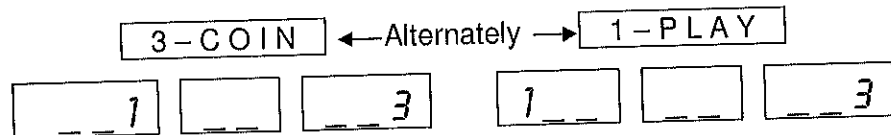

Press then release

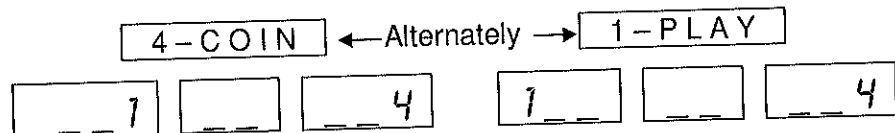

Press for then release to enter SET-UP 2

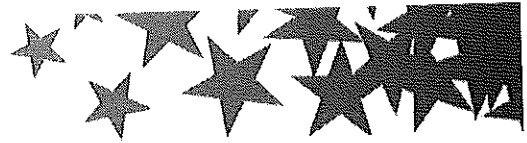

[SET-UP 2] Additional tickets

MIN-OUT

2 0

0 ticket dispensed after every game is ended

Press then release

2 1

Each time game over
Release 1 additional tickets

Press then release

2 2

Each time game over
Release 2 additional tickets

Press then release

2 3

Each time game over
Release 3 additional tickets

Press for 1 second then release to enter SET-UP 3

[SET-UP 3] Multiple of tickets

TICKET

3 00

No ticket, game play only
SET-UP 2 is ineffective.

Press then release

3 10

10 points : 1 ticket

Press then release

3 20

20 points : 1 ticket

Press then release

3 30

30 points : 1 ticket

Press then release

3 40

40 points : 1 ticket

Press then release

3 50

50 points : 1 ticket

Press then release

3 60

60 points : 1 ticket

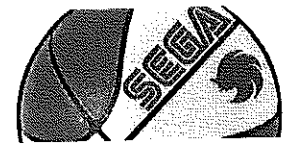

Press  TEST then release

70 points : 1 ticket

Press  TEST then release

80 points : 1 ticket

Press  TEST then release

90 points : 1 ticket

Press  TEST then release

100 points : 1 ticket

The explanation :

If the operator sets the game for 3__10 and the game is giving out tickets the player will receive 1 ticket for every 10 points scored . If the operator sets the game for 3__20 the player will get 1 ticket for every 20 points scored and so on.
For additional (0-3) tickets enter SET-UP 2

Press  AUDIT for 1 second then release to enter SET-UP 4

[SET-UP 4] Game Time SET-UP

GAME - TIME

Stage 1 : 50 seconds
Stage 2 : 40 seconds
Stage 3 : 30 seconds
Stage 4 : 20 seconds

Stage 1 : 55 seconds
Stage 2 : 45 seconds
Stage 3 : 35 seconds
Stage 4 : 25 seconds

Stage 1 : 60 seconds
Stage 2 : 50 seconds
Stage 3 : 40 seconds
Stage 4 : 30 seconds

Press  AUDIT for 1 second then release to enter SET-UP 5

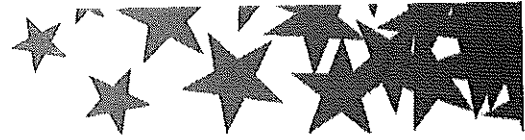

[SET-UP 5] Basket motor AUTO test

STE-MOT-1

Press  **TEST** then release-Start basketball motor AUTO test
(Warning alarm will start after 5 seconds, if there is an error)

Press  **AUDIT** for 1 second then release to enter SET-UP 6

[SET-UP 6] Ball holder motor AUTO test

STE-MOT-2

Press  **TEST** then release-Start ball holder motor AUTO test
(Warning alarm will start after 5 seconds, if there is an error)

Press  **AUDIT** for 1 second then release to enter SET-UP 7

[SET-UP 7] Reset the top score 250 or keep the record

→ Displays Company logo

Reset the top score to 250

Press  **TEST** then release

→ Displays Company logo

Keep the record

Press  **AUDIT** then release to enter SET-UP 8

[SET-UP 8] SET-UP DEMO music (ON or OFF)

→ Displays Company logo

DEMO music OFF

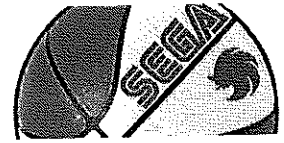

Press then release

→ Displays Company logo

DEMO music ON

※Restart the Machine to complete the SET-UP adjustment.

3.LED Monitor inspection

Testing :

1. Press and turn on the power in the same time to enter LED testing mode. Release the test button until is displayed "1" on the LED.
2. Check if the LED is displayed correctly.
3. When testing is finished you will enter into the standby function.

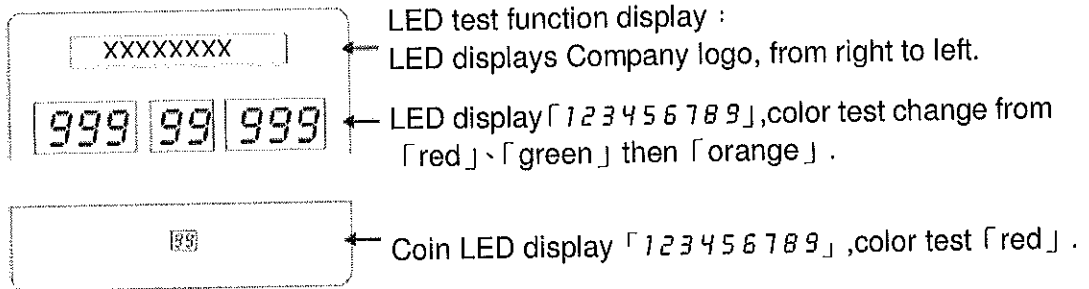

4. After AUTO test is finished, it will enter into standby function.

4.AUDIT

Press enter into audit system in standby function only.

Press then release, enter into { audit 1 }

Record total received
Coins up to 999999 same as counter,
counter reset is not allowed.

Press then release, enter into { audit 2 }

Record total dispensed tickets
Tickets up to 999999 same as counter,
no counter reset is not allowed.

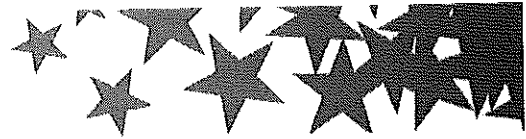

Press **AUDIT** then release, enter into [audit 3]

SHIFT - IN
3CX XX XXX

Record total received
Coins up to 999999,
counter reset is allowed.

Press **AUDIT** then release, enter into [audit 4]

SHIFT - OUT
3CX XX XXX

Record total dispensed tickets
up to 999999,
counter reset is allowed.

Press **AUDIT** then release, return back to audit function [The end]

XXXXXX → Displays Company logo
 55

※Press **AUDIT** then release, enter into standby function.

※Press **TEST** then release, return back to **[audit 3]** function. And reset the **[audit 3]** and **[audit 4]** .

5. Error code

Every time machine is turned on it will do the AUTO test for 7 function points, Before entering into standby function.

The Error specification as below,

- | | |
|---|--|
| <p>[Error 1] COIN - 1</p> | <p>Warning alarm action
Left coin selector is disconnected
Left coin selector didn't turn in to NC
Left coin selector error</p> |
| <p>[Error 2] COIN - 2</p> | <p>Warning alarm action
Right coin selector is disconnected
Right coin selector didn't turn in to NC
Right coin selector error</p> |
| <p>[Error 3] SET-MOT - 1</p> | <p>Warning alarm action
Basket motor power is disconnected
Basket SENSOR-NO
Basket is out of position</p> |

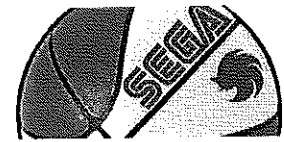

[Error 4] SET-MOT - 2

Warning alarm action
Ball holder motor power is disconnected
Ball holder SENSOR-NO
Ball holder is out of position

[Error 5] TICKET

Warning alarm action
Ticket dispenser is disconnected
Ticket dispenser adjustment error No tickets
Press  TEST for clean tickets.

[Error 6] COUNT - IN

Warning alarm action
Coin counter is disconnected
Coin counter error

[Error 7] COUNT-OUT

Warning alarm action
Ticket counter is disconnected
Ticket counter tickets

VI.How to play

1.There are total 4 Stages

- A.Stage 1 : Proceed to Stage 2,when the total scores are over 40 in the end.
- B.Stage 2 : Proceed to Stage 3,when the total scores are over 150 in the end.
- C.Stage 3 : Proceed to Stage 4,when the total scores are over 250 in the end.
- D.Stage 4 : Final challenge, the last game will be finished when the time is terminated.

2.2 play types available















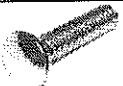

- A.Single play : DIP-SW set to single play.
- B.Link mode : DIP-SW set to link mode, up to 15 machines can be linked.
Press link mode, display link countdown time, any other machine can be linked together during the countdown. In link mode, up to 15 machines can be linked.



When the machine is in standby function, the SW is ineffectual.



VII.Screw and Nut list

NO	picture	Specification	Total quantity	Position
1		screw(M4x12)	68	set
2		screw (M4x10)	21	set
3		screw (M3x5)	26	set
4		screw(M8x88)	4	Knock down machine Step 7
				Semi-assemble machine Step 4
5		screw (M5x20)	8	set
6		screw (M5x20)	8	set
7		screw (M5)	4	set
8		screw(M8x16)	4	Knock down machine Step 7
				Semi-assemble machine Step 4
9		screw (M6x55)	1	set
10		screw (M6x48)	14	Knock down machine Step 3.5.6
			12	Semi-assemble machine Step 2
11		screw (M6x26)	20	Knock down machine Step 5.6
			14	Semi-assemble machine Step 2.3
12		screw (M6x16)	16	set
13		screw (M5x15)	6	Knock down machine Step 2
14		screw (M4x15)	4	set
15		screw (M4x12)	58	set
16		screw (M4x8)	8	set
17		screw (M3x12)	2	set

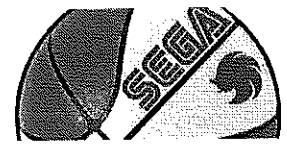

NO	picture	Specification	Total quantity	Position
18		screw (M3x10)	1	set
19		nut(M8)	16	Knock down machine Step 4.7
			12	Semi-assemble machine Step 1.4
20		nut (M6)	38	Knock down machine Step 3.5.6.11
			20	Semi-assemble machine Step 2.3.8
21		nut (M5)	6	Knock down machine Step 2
22		nut (M4)	20	set
23		nut (M6)	4	set
24		nut (M5)	8	set
25		nut (M4)	44	set
26		nut (M3)	7	set
27		sleeve (φ 15x43)	4	Knock down machine Step 7
				Semi-assemble machine Step 4
28		screw (M5x38)	4	Knock down machine Step 9
				Semi-assemble machine Step 6
29		washer(M4x12)	4	Knock down machine Step 9
				Semi-assemble machine Step 6
30		washer (M6.5x13.5)	24	Knock down machine Step 6.7
			12	Semi-assemble machine Step 3.4
31		Hexagonal Phillips screw with 2 Washers	4	Knock down machine Step 7
				Semi-assemble machine Step 4
32		screw (M4x10)	48	Knock down machine Step 1
33		screw (M8x70)	8	Knock down machine Step 3.4
			4	Semi-assemble machine Step 1

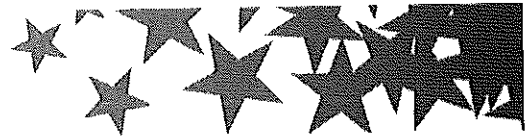

VIII. Wires Layout

Sonic Basketball Wire diagram

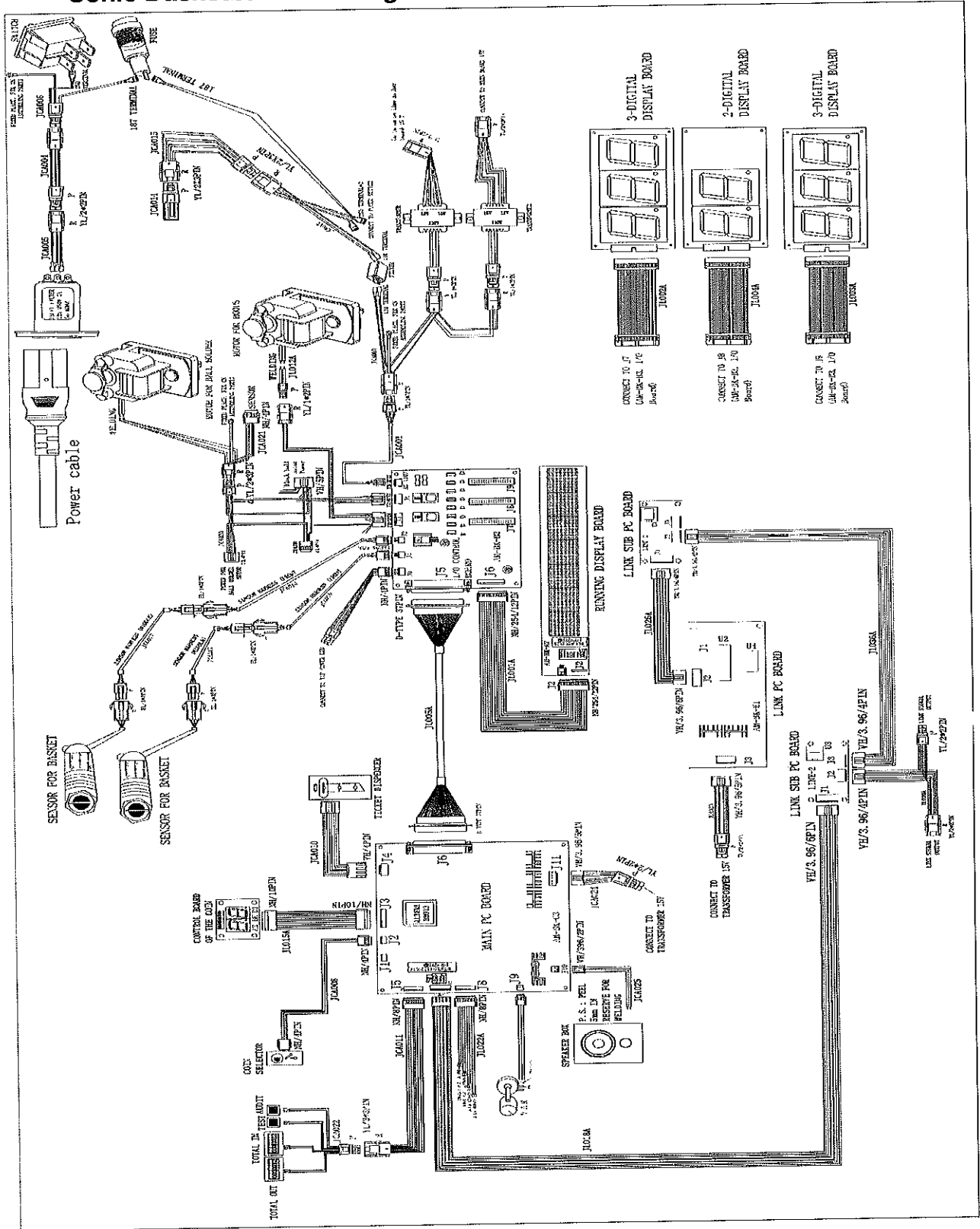

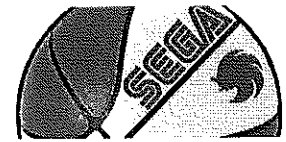

IX.Expended view

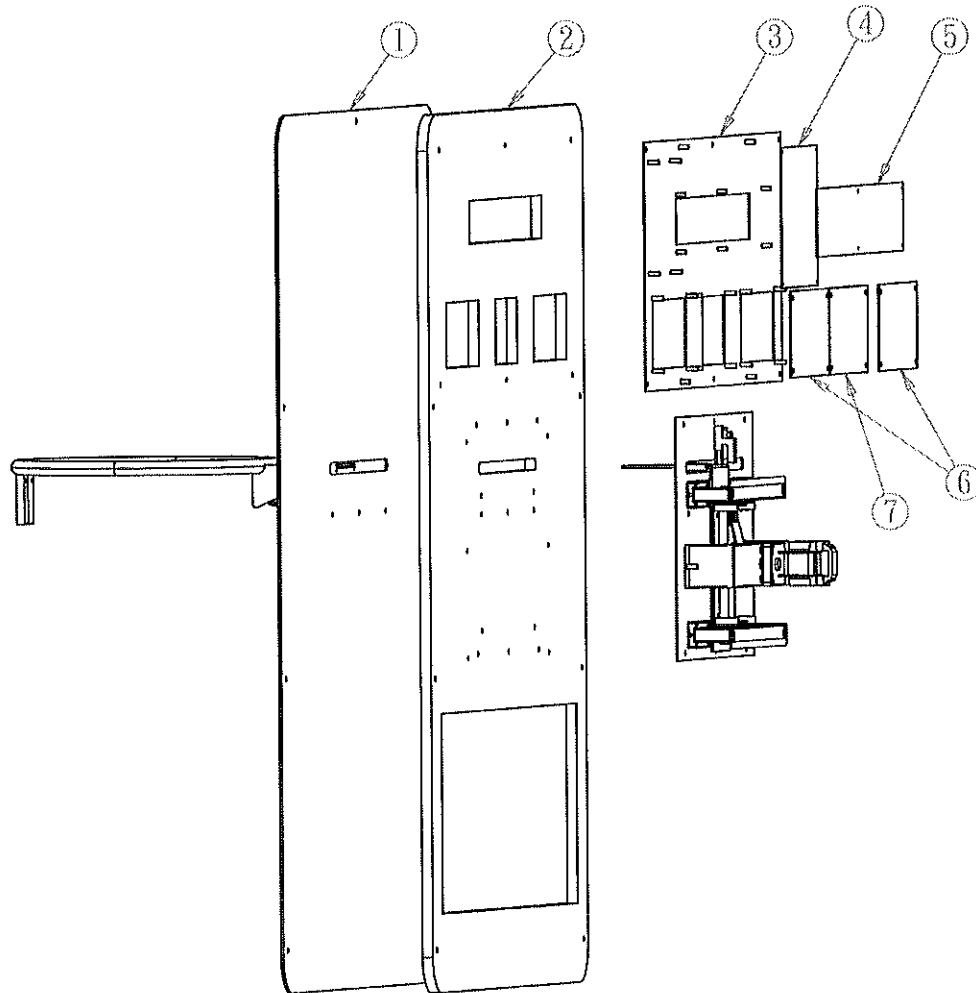

Item	Name	Part Number	Quantity
1	Basket acrylic board (SEGA)	1121-13800802	1
2	Wooden basket board (SEGA)	2246-13800501	1
3	Main wooden board(SEGA)	1134-13801701	1
4	I/O control board (SEGA)	2213-13800101	1
5	Running display board (SEGA)	2212-13800201	1
6	3 Digital display board (SEGA)	2212-13800401	2
7	2 Digital display board (SEGA)	2212-13800301	1

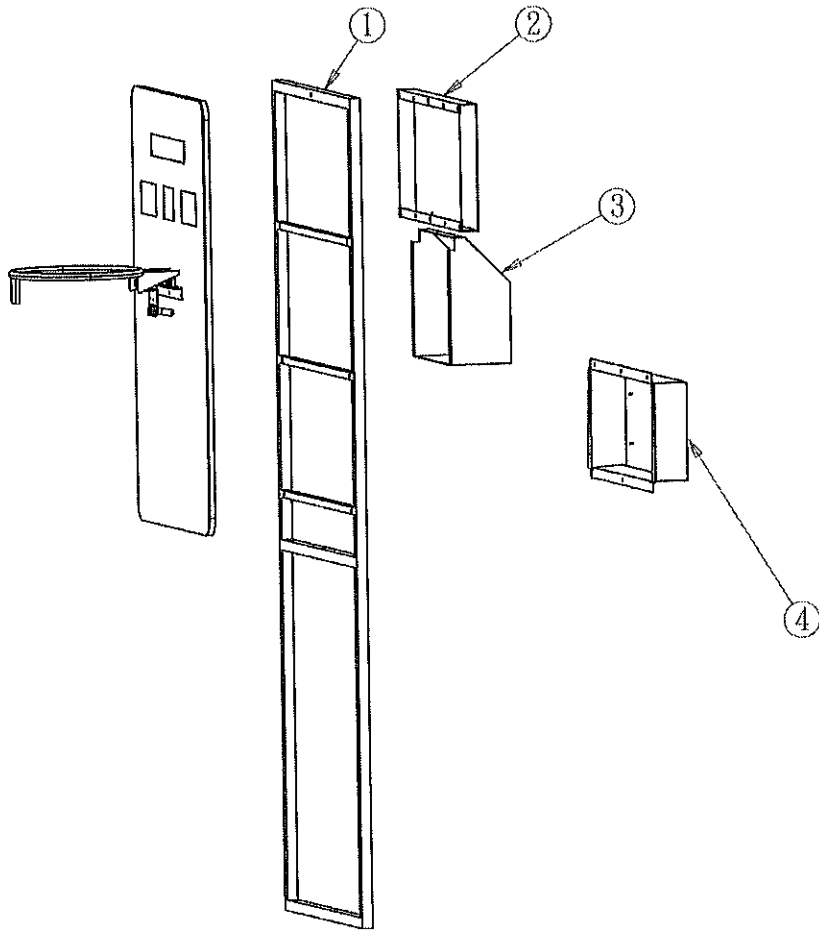
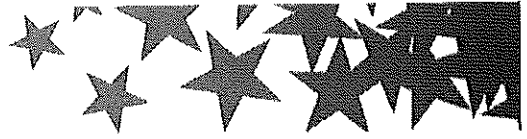

Item	Name	Part Number	Quantity
1	Frame for main wooden board fix use (SEGA)	1134-13850411	1
2	Board cover (SEGA)	1134-13850561	1
3	Basket cover (SEGA)	1134-13850571	1
4	Box cover (SEGA)	1134-13850581	1

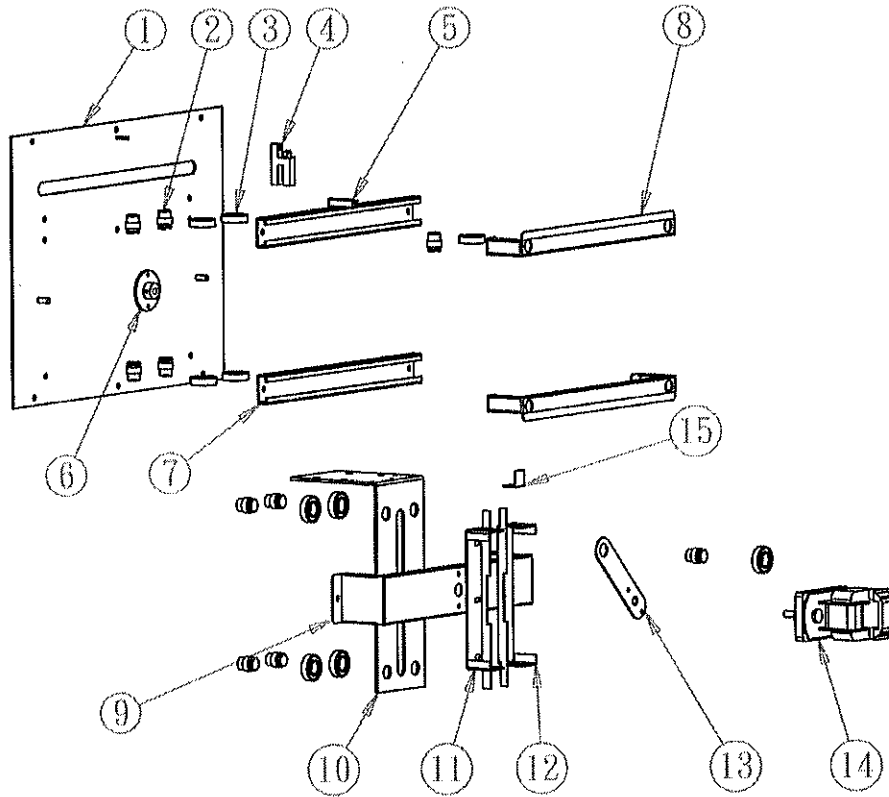
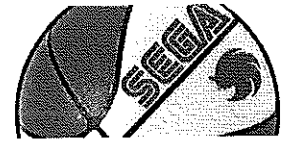

Item	Name	Part Number	Quantity
1	Wooden board for basket unit fix use(SEGA)	1134-13801101	1
2	Bearing (SEGA)	1151-13800301	9
3	Bearing (6002ZZ)(SEGA)	1243-13800101	9
4	Sensor 1.1 (SEGA)	2213-13800301	1
5	Sliding railway for sensor(SEGA)	1134-13802901	1
6	Bearing D-Type for Basket(SEGA)	1151-13800101	1
7	Sliding railway for basket(SEGA)	1134-13801601	2
8	Bearing cover(SEGA)	1132-13802601	2
9	Basket motor holder(SEGA)	1132-13801101	1
10	Basket holder(SEGA)	1132-13801431	1
11	Basket left holder(SEGA)	1132-13802701	1
12	Basket right holder	1132-13802801	1
13	Connecting rod for basket unit(SEGA)	1134-13801001	1
14	Gear motor (KGB-215-8130B1)(SEGA)	0912-00001061	1
15	Basket position board(SEGA)	1134-13803001	1

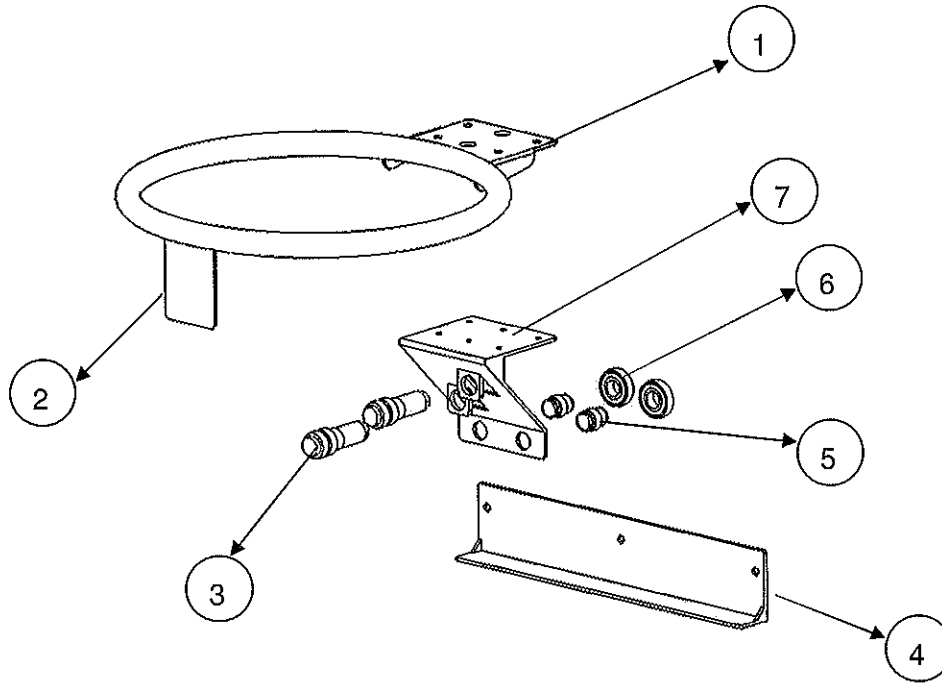
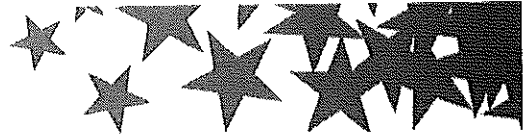

Item	Name	Part Number	Quantity
1	Basket net kit(SEGA)	1134-13800741	1
2	3M reflection sticker(SEGA)	1032-13800941	1
3	Sensor for basket (WO-RNPW2) (SEGA)	0955-13800001	2
4	Basket sensor railway(SEGA)	1134-13807141	1
5	Bearing (SEGA)	1151-13800301	2
6	Bearing (6002ZZ)(SEGA)	1243-13800101	2
7	Holder for basket sensor(SEGA)	1132-13801331	1

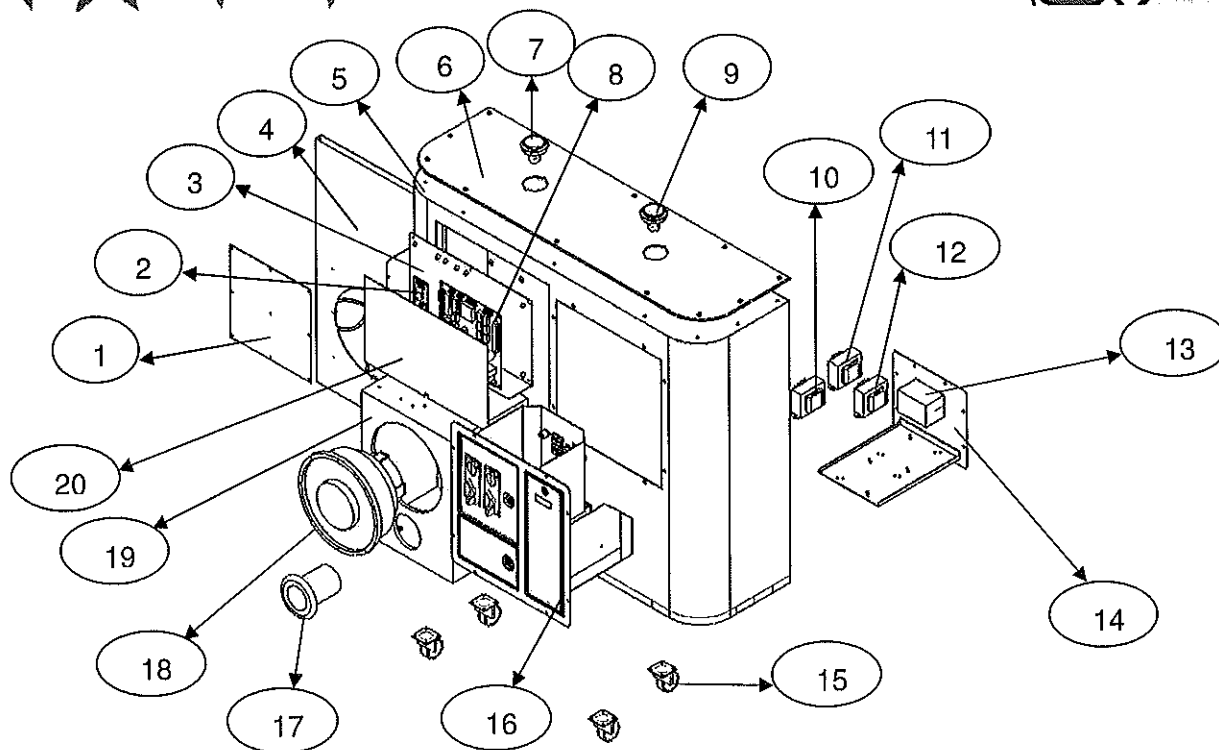
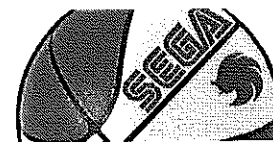

Item	Name	Part Number	Quantity
1	Hole type cover (SEGA)	1134-13850601	1
2	Link Sub IC Board (SEGA)	2215-13800201	1
3	Main box base (SEGA)	1134-13850631	1
4	The door of speaker(SEGA)	1134-13850611	1
5	Main part (SEGA)	1134-13850591	1
6	Main part acrylic board (SEGA)	1121-13800881	1
7	1P playpush button (SEGA)	2243-13800301	1
8	Single main IC board (SEGA)	2211-13800101	1
9	Team play push button (SEGA)	2243-13800401	1
10	Transformer 220V/110V 2A(SEGA)	0923-10000191	1
11	Transformer 110V/15V 3A*2(SEGA)	0923-10000181	1
12	Transformer 110V/15V 3A*2(SEGA)	0923-10000181	1
13	The knob for wooden box(SEGA)	1119-00000001	1
14	Base for transformer fixed use (SEGA)	1134-13850651	1
15	Castor(SEGA)	1155-00010111	4
16	3 in 1 door (SEGA)	2239-13800701	1
17	Ventilation duct of speaker box (SEGA)	1294-00000202	1
18	Speaker (SEGA)	0931-10000015	1
19	Speaker box (SEGA)	2246-13800401	1
20	Cover for IC board (SEGA)	1134-13850641	1

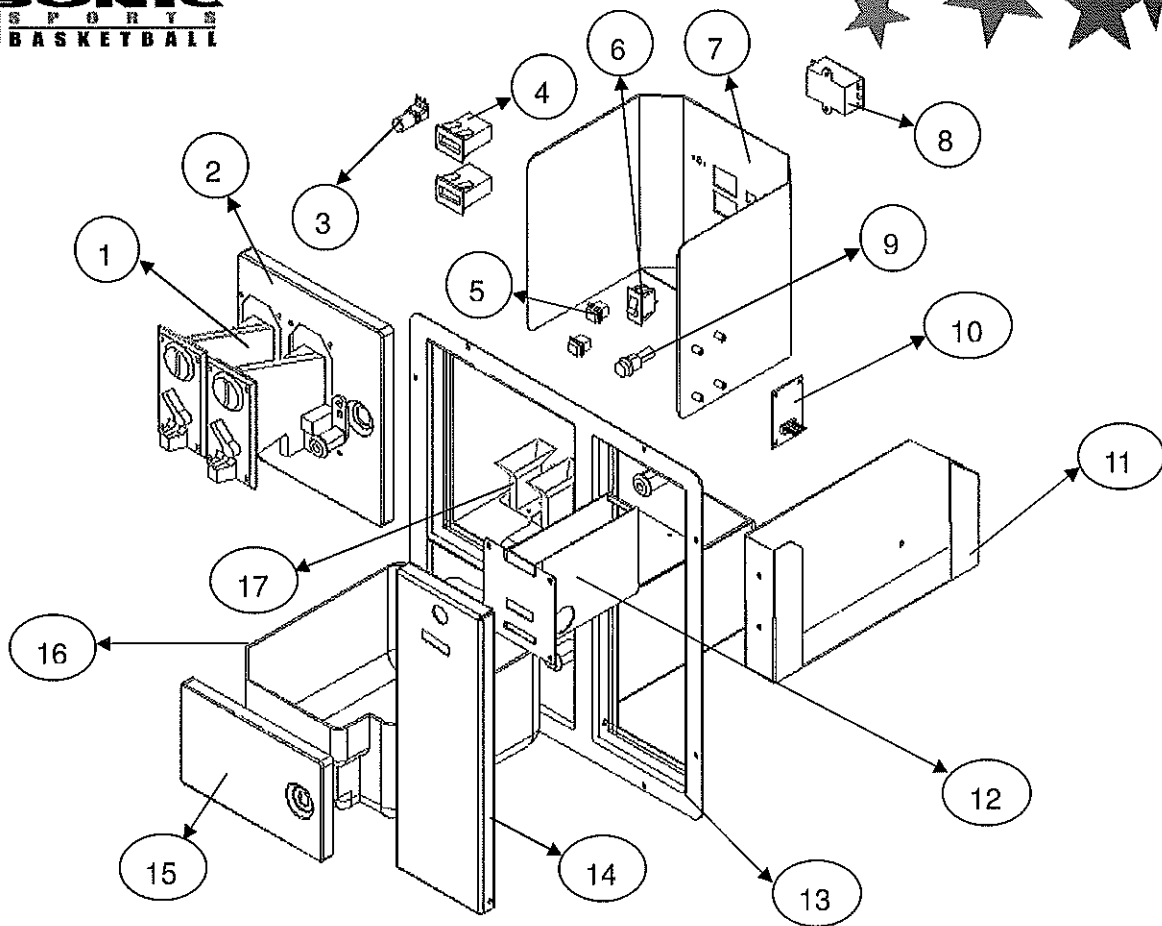
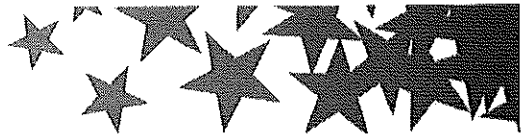

Item	Name	Part Number	Quantity
1	Coin selector (SEGA)-TW400	1291-10000041	2
2	Coin door with hinge (SEGA)	1134-00000145	1
3	Variable resistor 10K 3P(SEGA)	0106-00001001	1
4	Counter (SEGA)	0922-00001081	2
5	Audit push button (Red) (SEGA)	0944-00000091	2
6	Ship-Type switch(SEGA)	0944-00000141	1
7	Socket for counter (SEGA)	1134-13850621	1
8	Filter YG03T5 (3A)(SEGA)	0924-00000101	1
9	Fuse R3-11 20mm(SEGA)	0974-00001001	1
10	Ticket control board(SEGA)	2213-13100201	1
11	Ticket container(SEGA)	1134-00000035	1
12	Ticket dispenser(SEGA)	0918-00001011	1
13	Frame of 3 in 1 (SEGA)	1134-00000085	1
14	Ticket door with hinge (SEGA)	1134-00000115	1
15	Cash box door with hinge (SEGA)	1134-00000105	1
16	Cash box (SEGA)	1134-00000045	1
17	Coin Drop Plastic	1134-05000101	2

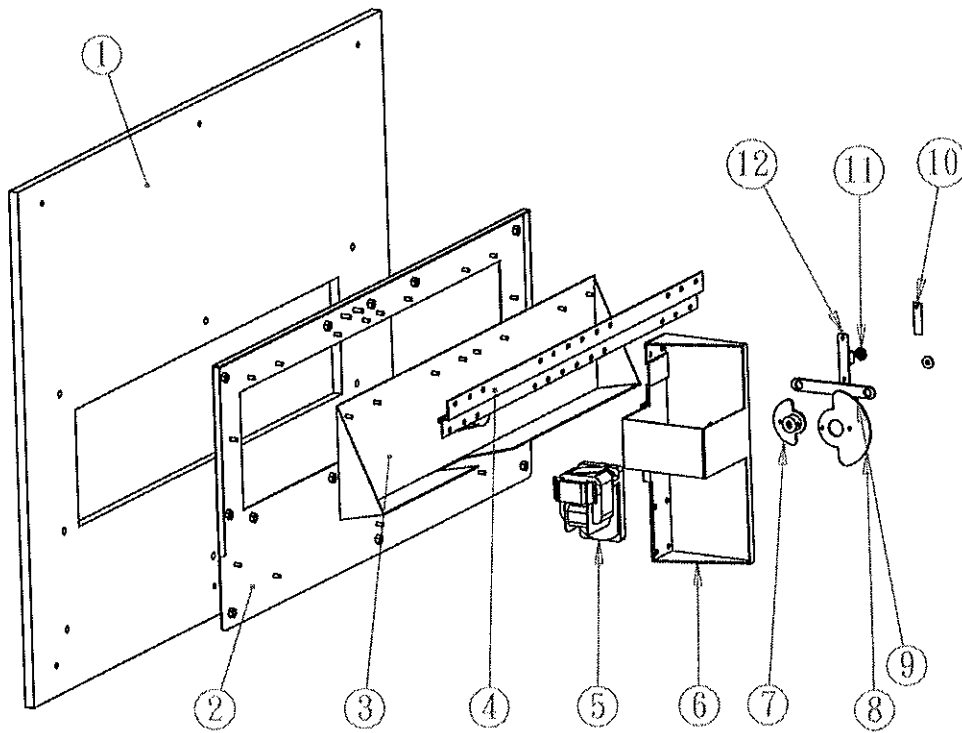
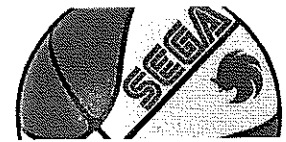

Item	Name	Part Number	Quantity
1	Wooden board B-type (SEGA)	2246-13802101	1
2	Base of ball holder unit (SEGA)	1134-13850671	1
3	Ball holder kit (SEGA)	1134-13850681	1
4	Hinge for ball holder (650*46.6)(SEGA)	1134-13803301	1
5	Gear Motor KGB-215-6130B1(SEGA)	0912-00001061	1
6	Motor Frisked for ball holder kit(SEGA)	1134-13850661	1
7	Bearing D-Type for ball holder(SEGA)	1151-13800201	1
8	Ball holder bearing(SEGA)	1134-13804201	1
9	Arm of ball holder(SEGA)	1134-13802501	1
10	SENSOR 1.1 (SEGA)	2213-13800301	1
11	Bearing LF-1040(SEGA)	1243-13800301	2
12	Bracket for ball holder sensor fixed use(SEGA)	1132-13803001	1

