

監修：庵野 秀明
発行：カラー



Groundwork of EVANGELION

The Movie 2

新世紀エヴァンゲリオン劇場版原画集

Groundwork of
EVANGELION
The Movie 2

新世紀エヴァンゲリオン劇場版原画集



目次

はじめに、そしておわりに	33
まごころを、君に	34
劇場版 # 25 設定資料	335
劇場版 # 26 設定資料	346
【特典】	353

Groundwork of EVANGELION The Movie 2

新世紀エヴァンゲリオン劇場版原画集

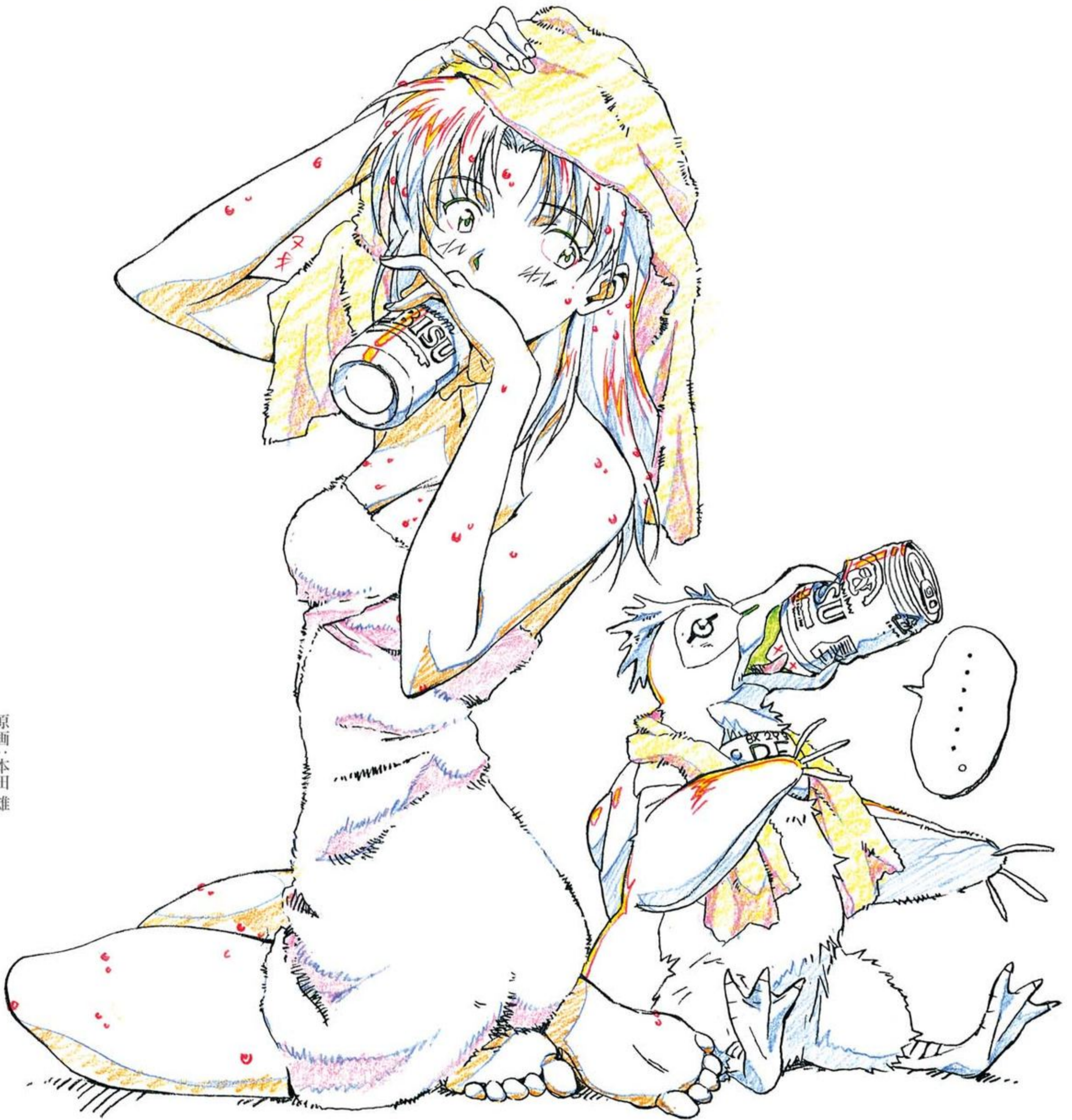

原画：本田雄
初出：新世紀エヴァンゲリオンLDシリーズ第2巻ライナーノート

監修：庵野秀明



原画：本田雄
初出：新世纪エヴァンゲリオンV.T・LDシリーズ 第2巻ジャケット



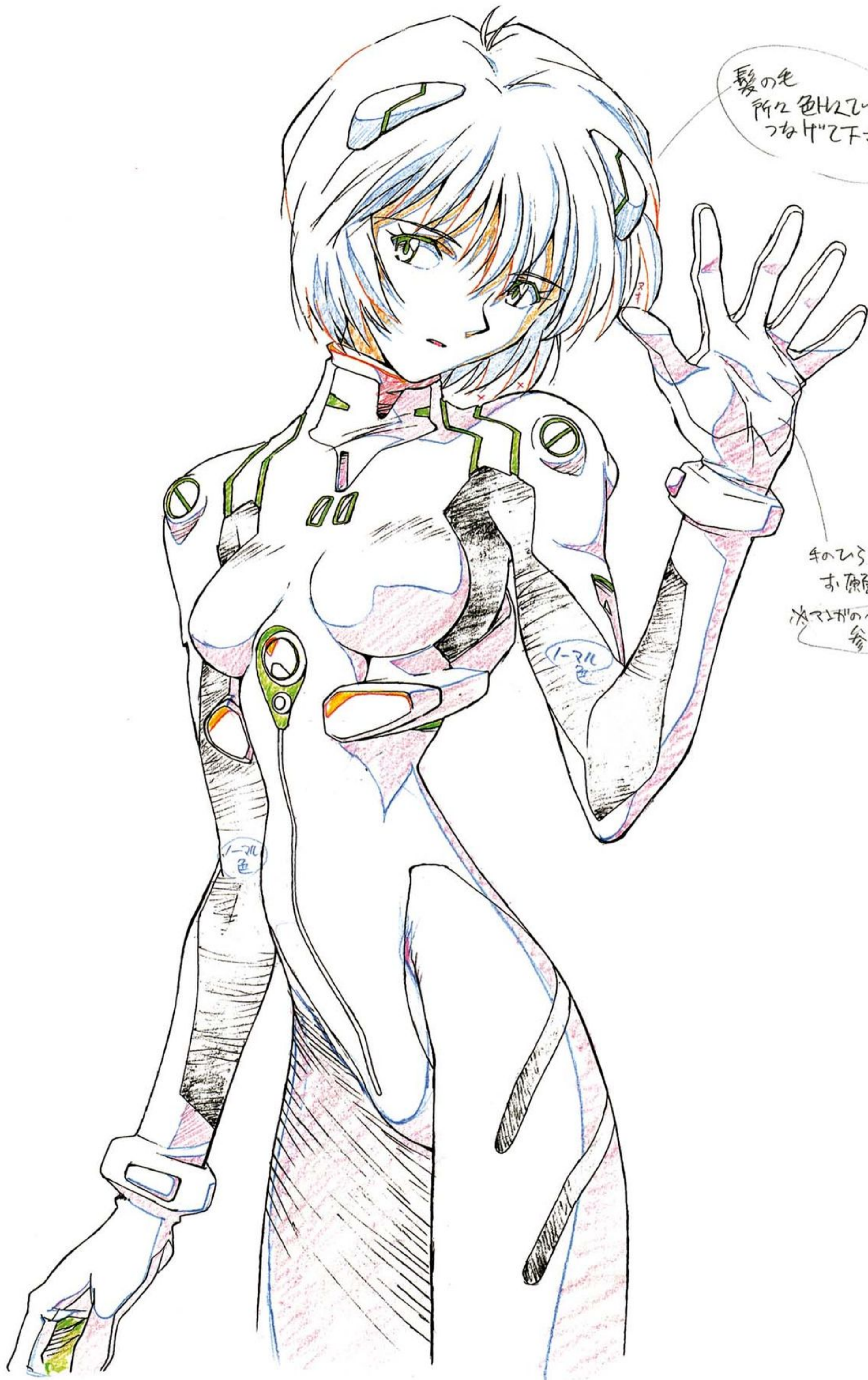

髪の色
所々色は
つなげて下マ!!

手の色か
す原画は
*マサカのイラスト
参考

1-2L
色

1-2L
色

原画：本田雄
初出：新世纪エヴァンゲリオンV.T.LDシリーズ 第4巻ジャケット

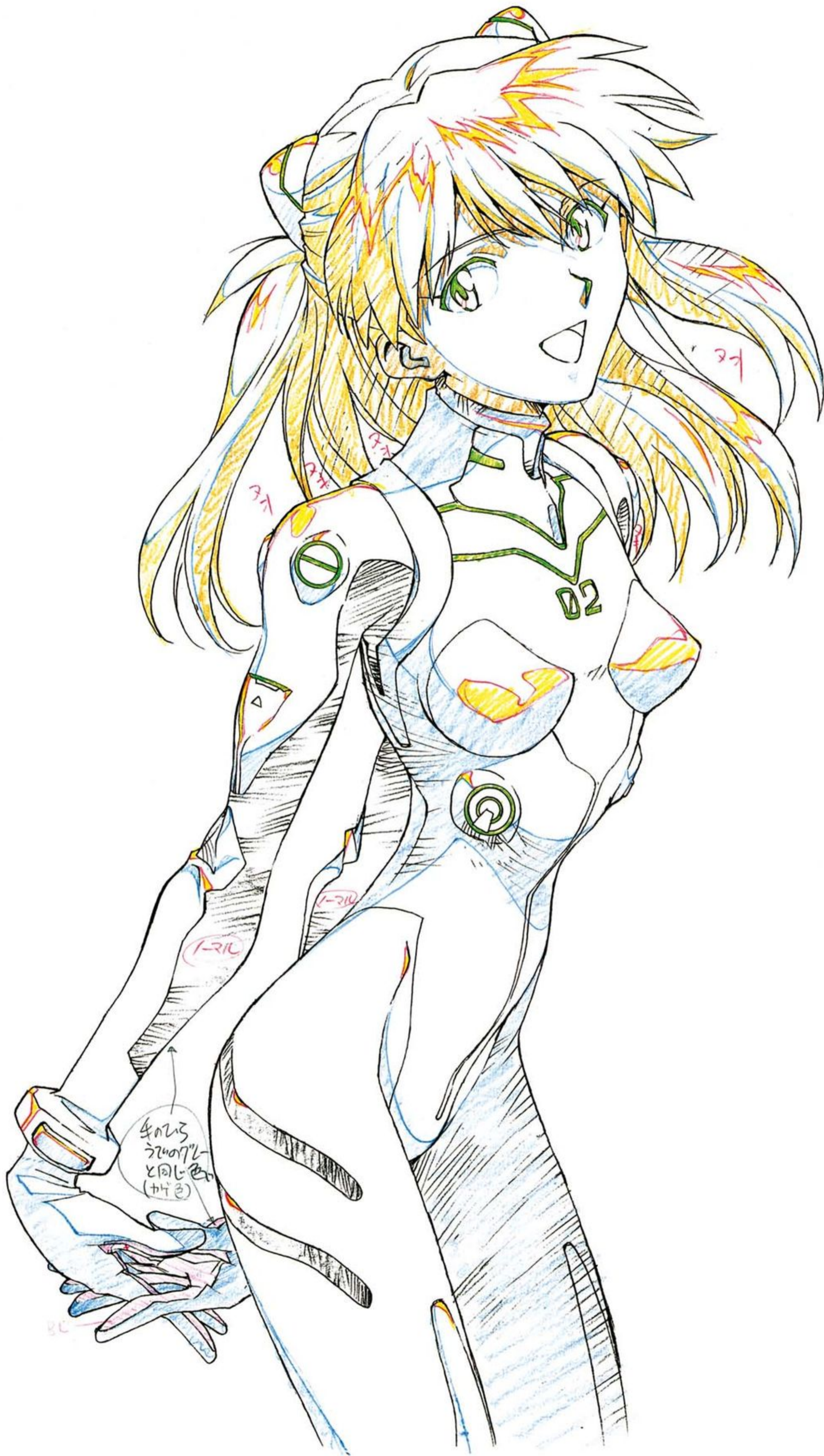

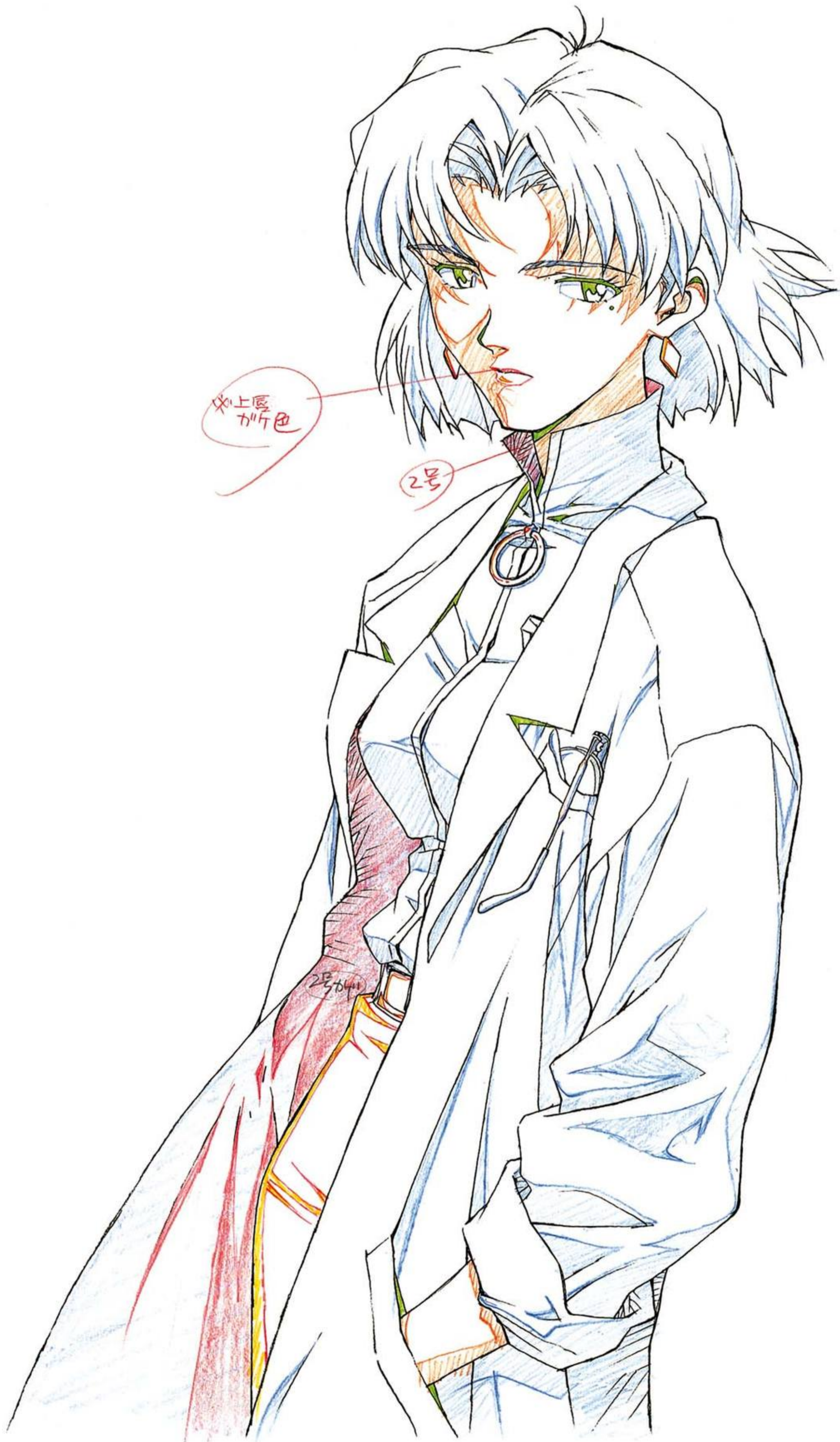

原画：本田雄
初出：新世紀エヴァンゲリオンV.T・LDシリーズ 第6巻ジャケット







原画：本田雄
初出：新世纪エヴァンゲリオンV.T・LDシリーズ 第8巻ジャケット



このブルーとお原画の色

* 加色
暗い方の1/10-1/20
お原画の色

♪
二人には
しんちゃん
めったしか
ままよら

* 光球
白、白、茶色
お原画の色

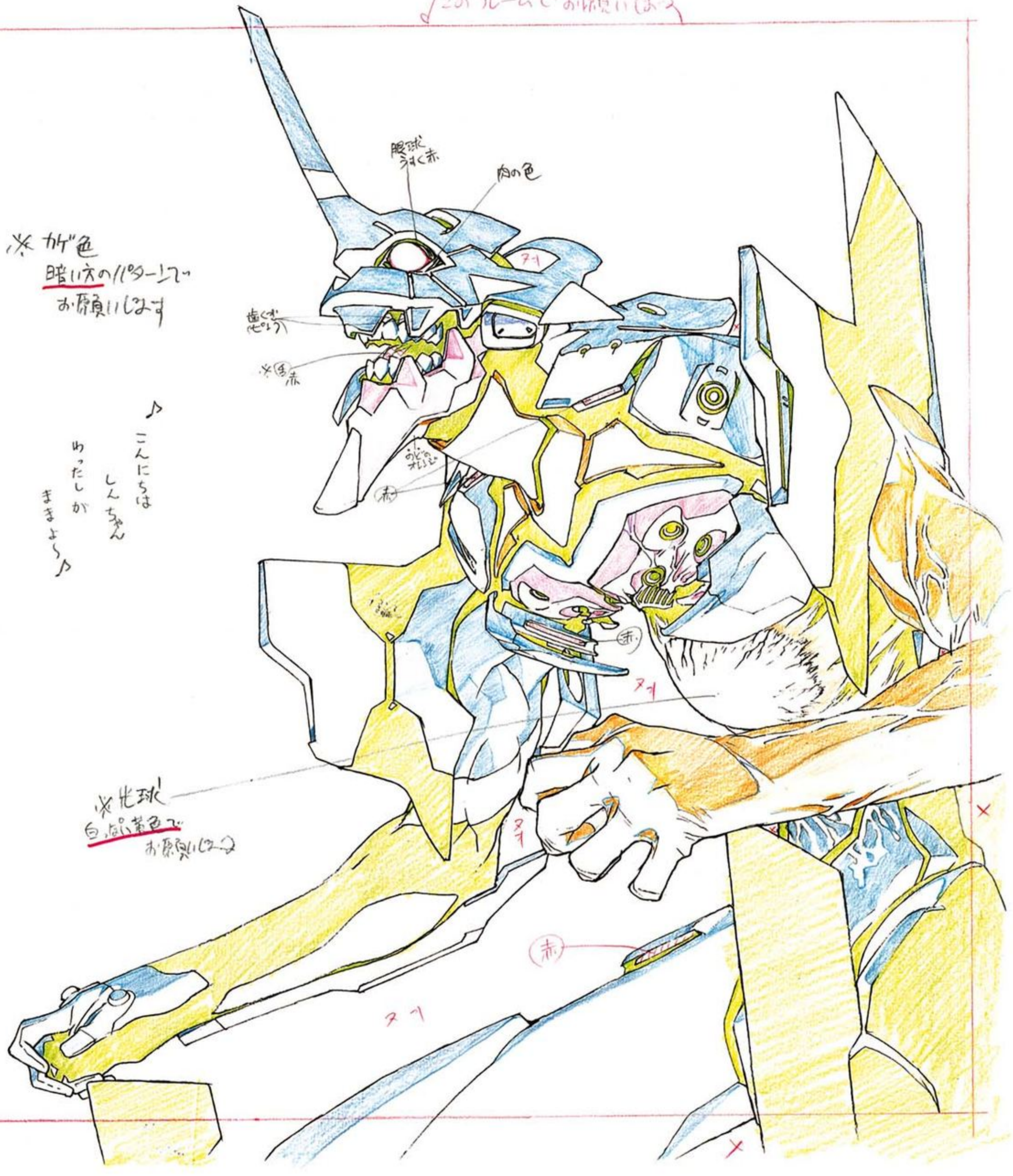

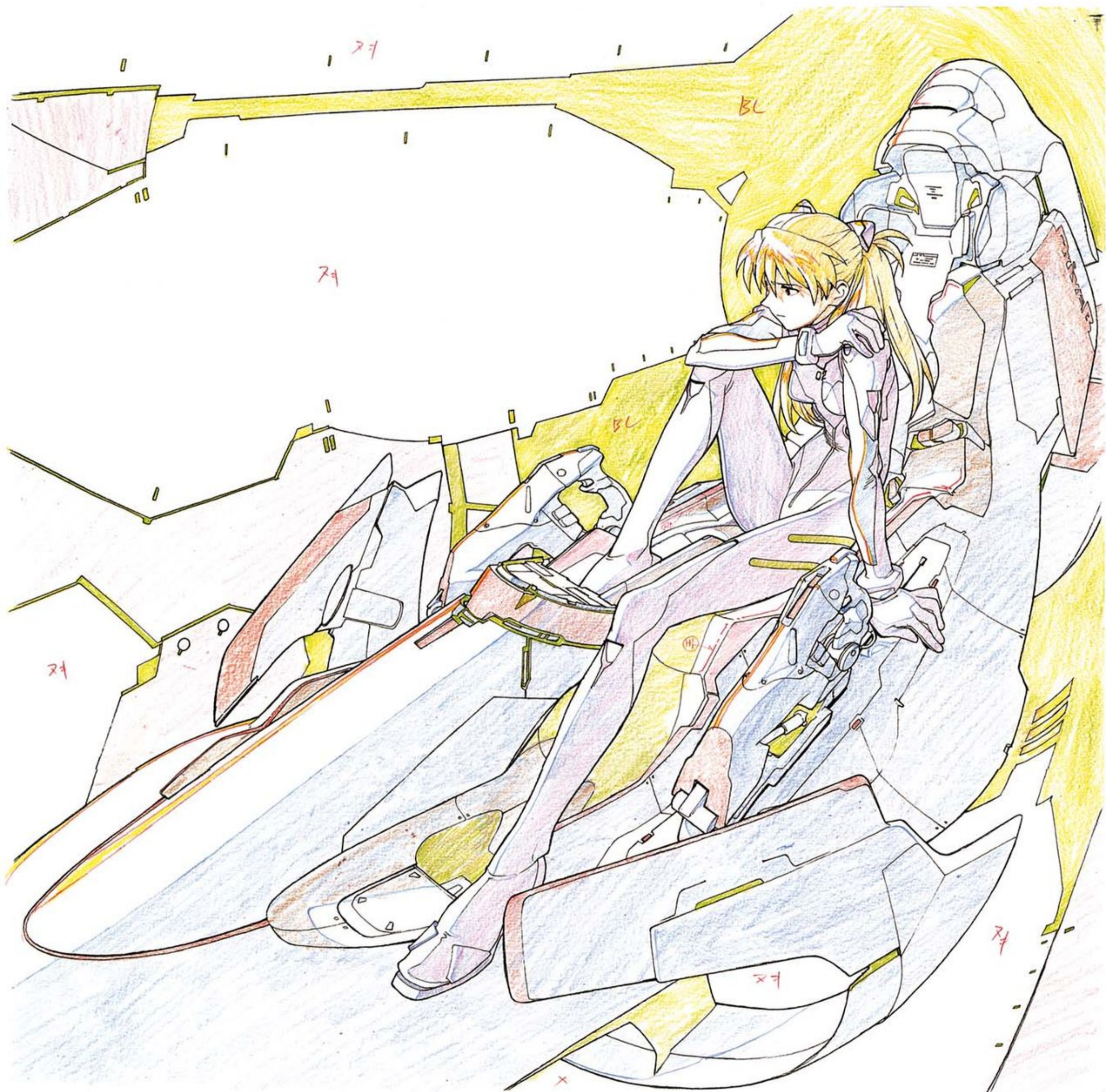

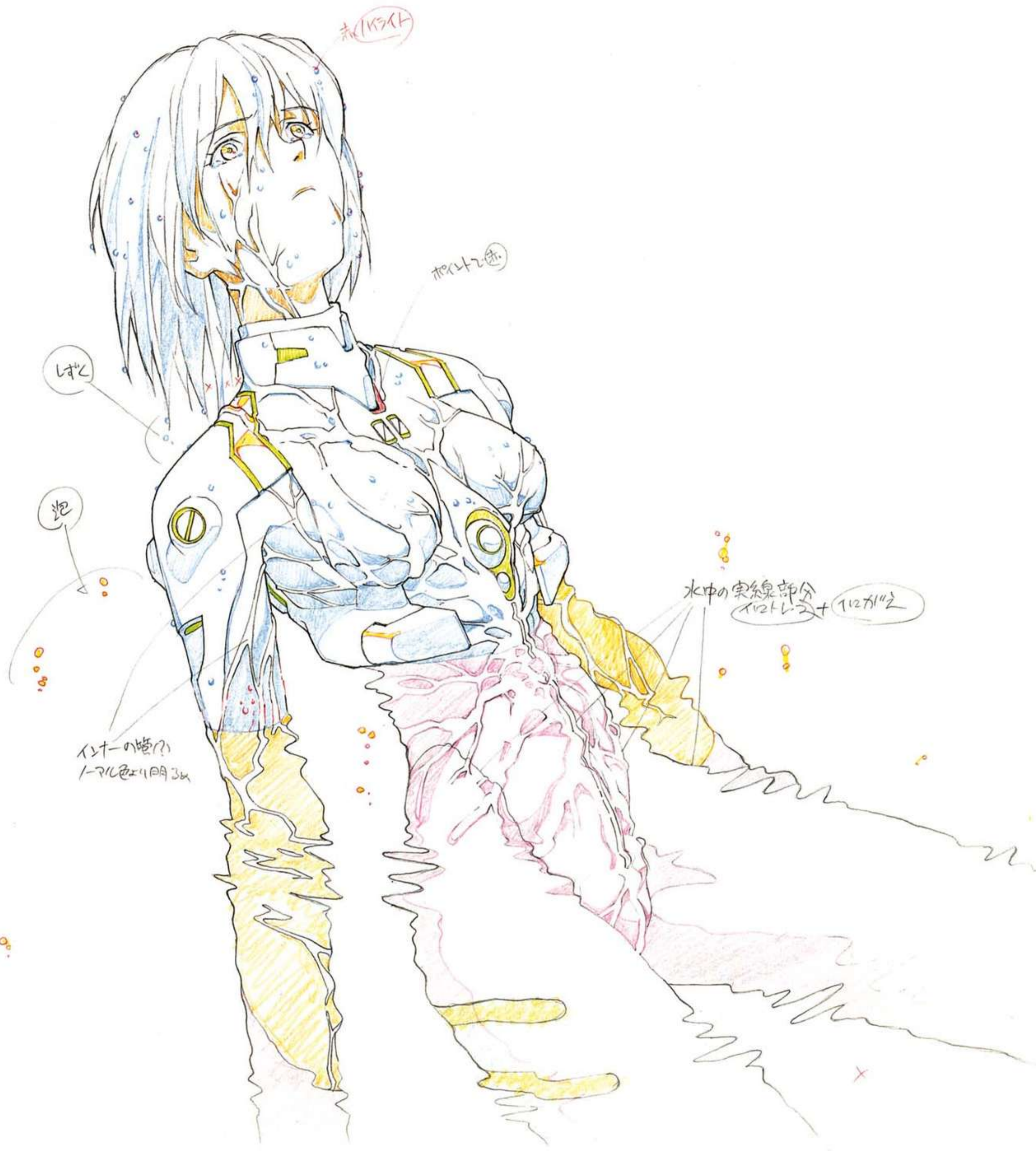





原画：本田 雄

初出：新世紀エヴァンゲリオンVT・LDシリーズ 第14巻ジャケット

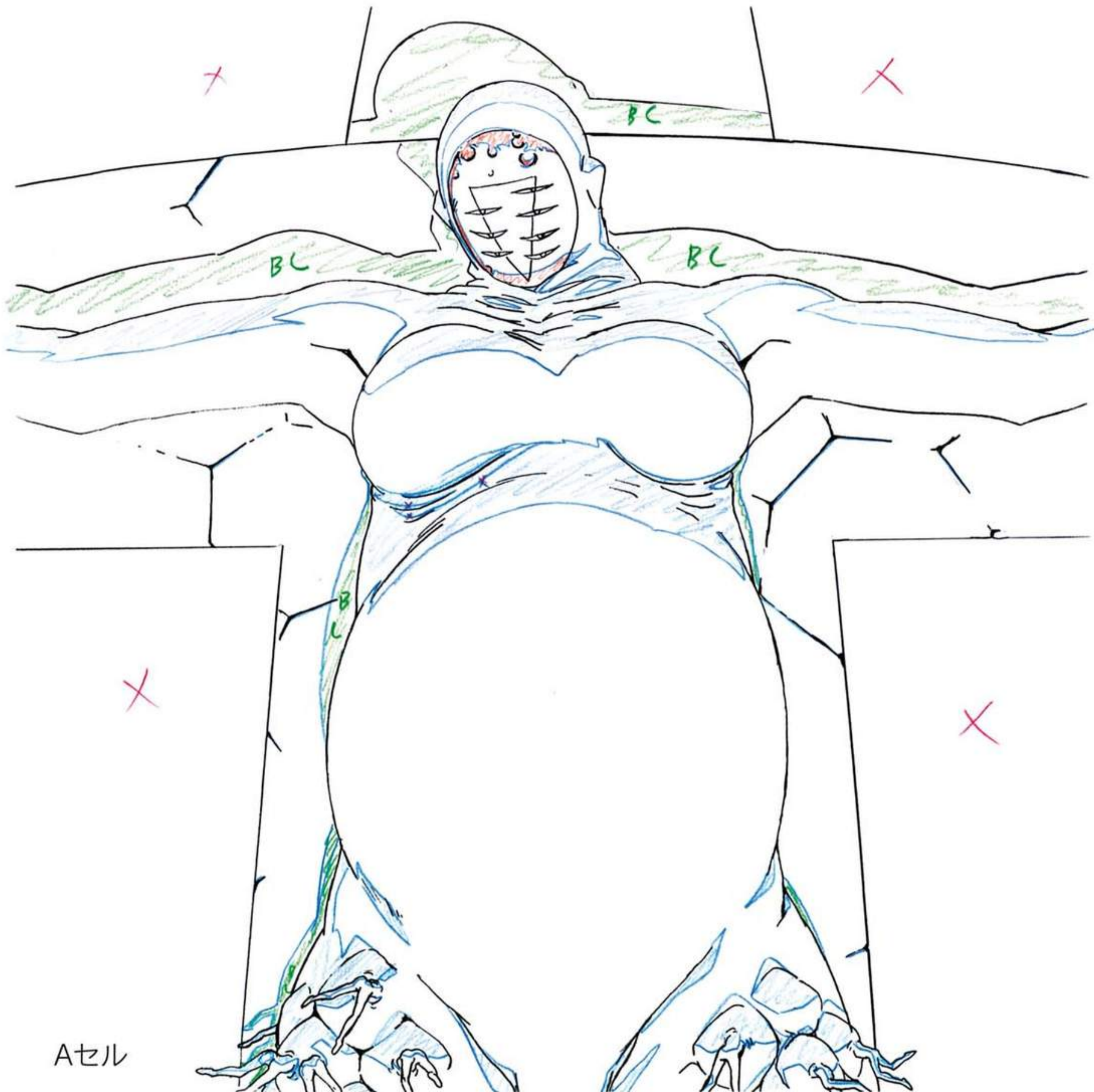

Aセル

Dセル



肌カサ色トブラシ(グラサ)

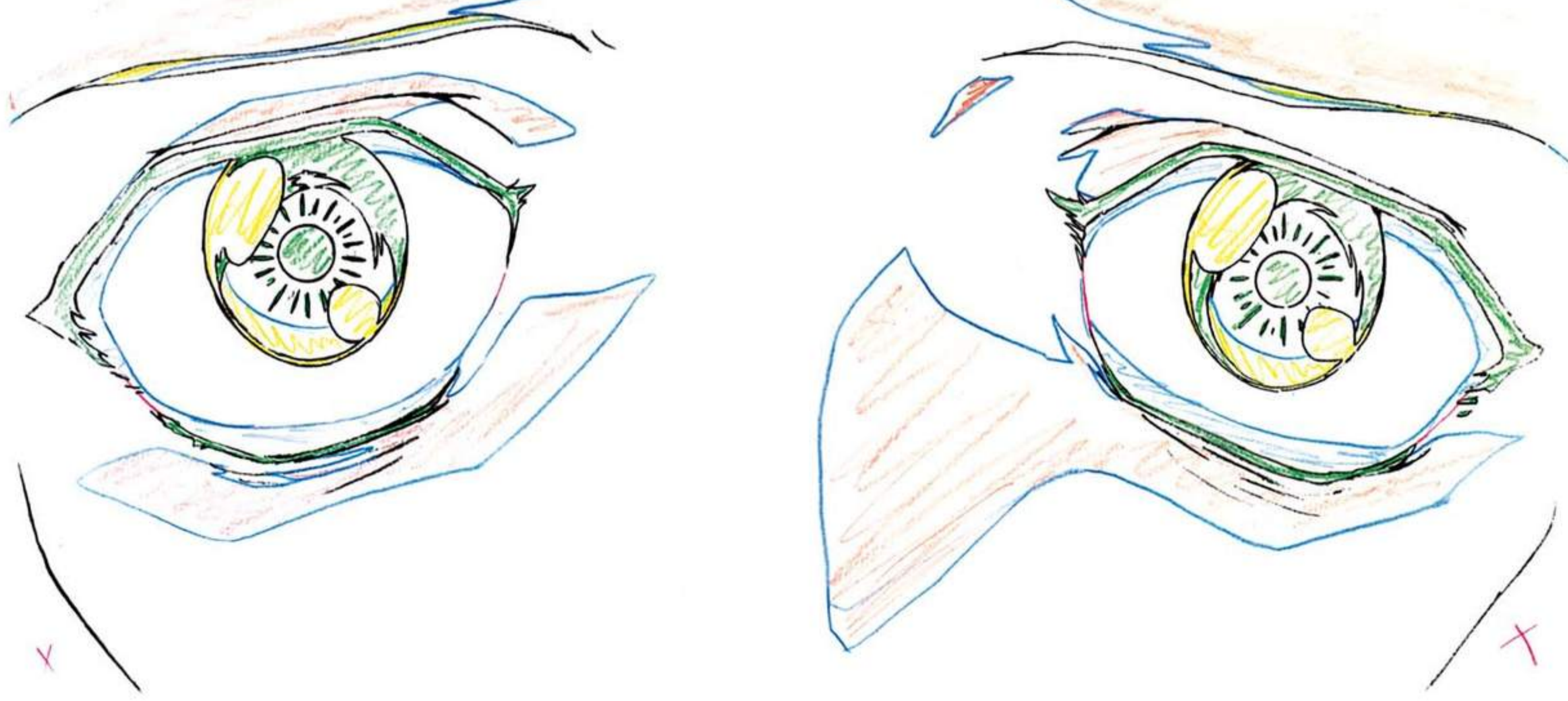

Cセル

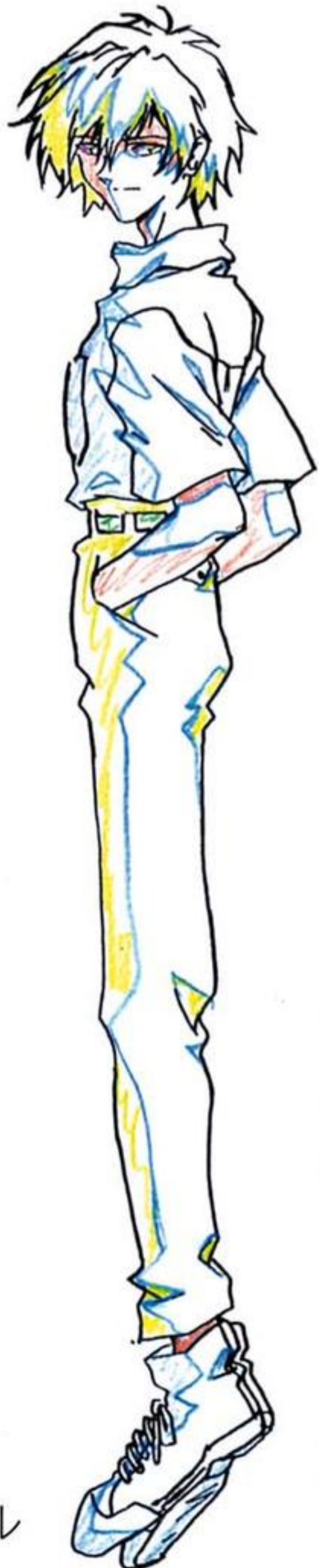

↓ シャツ色でブラシ
 ↑ 濃く
 ↓ 薄く



Bセル

原画：摩砂雪
 初出：新世紀エヴァンゲリオン劇場版
 LDBOXジャケット



原画：本田 雄
初出：新世紀エヴァンゲリオン劇場版LDBOXジャケット
(原画所在不明のため、カラーのみ掲載)

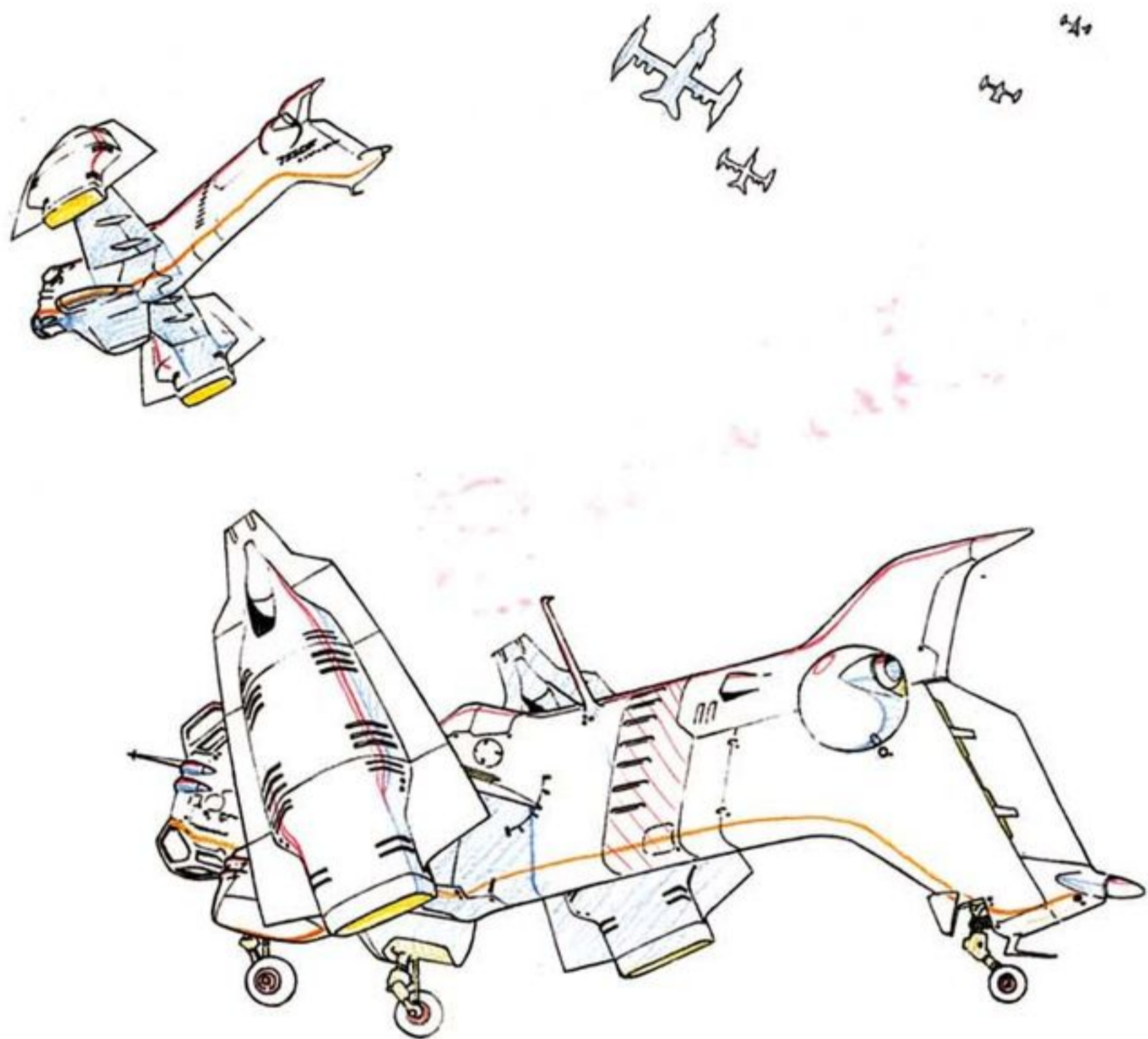

原画：鶴巻 和哉
初出：新世紀エヴァンゲリオン劇場版LDBOXジャケット



イラスト: 鈴木 俊二
初出: 新世紀エヴァンゲリオン劇場版LDBOXジャケット



イラスト: 貞本 義行
初出: 新世紀エヴァンゲリオン劇場版LDBOXパッケージ





イラスト: 山下いくと
初出: 新世紀エヴァンゲリオンLDシリーズ 初回製造分特製BOXパッケージ







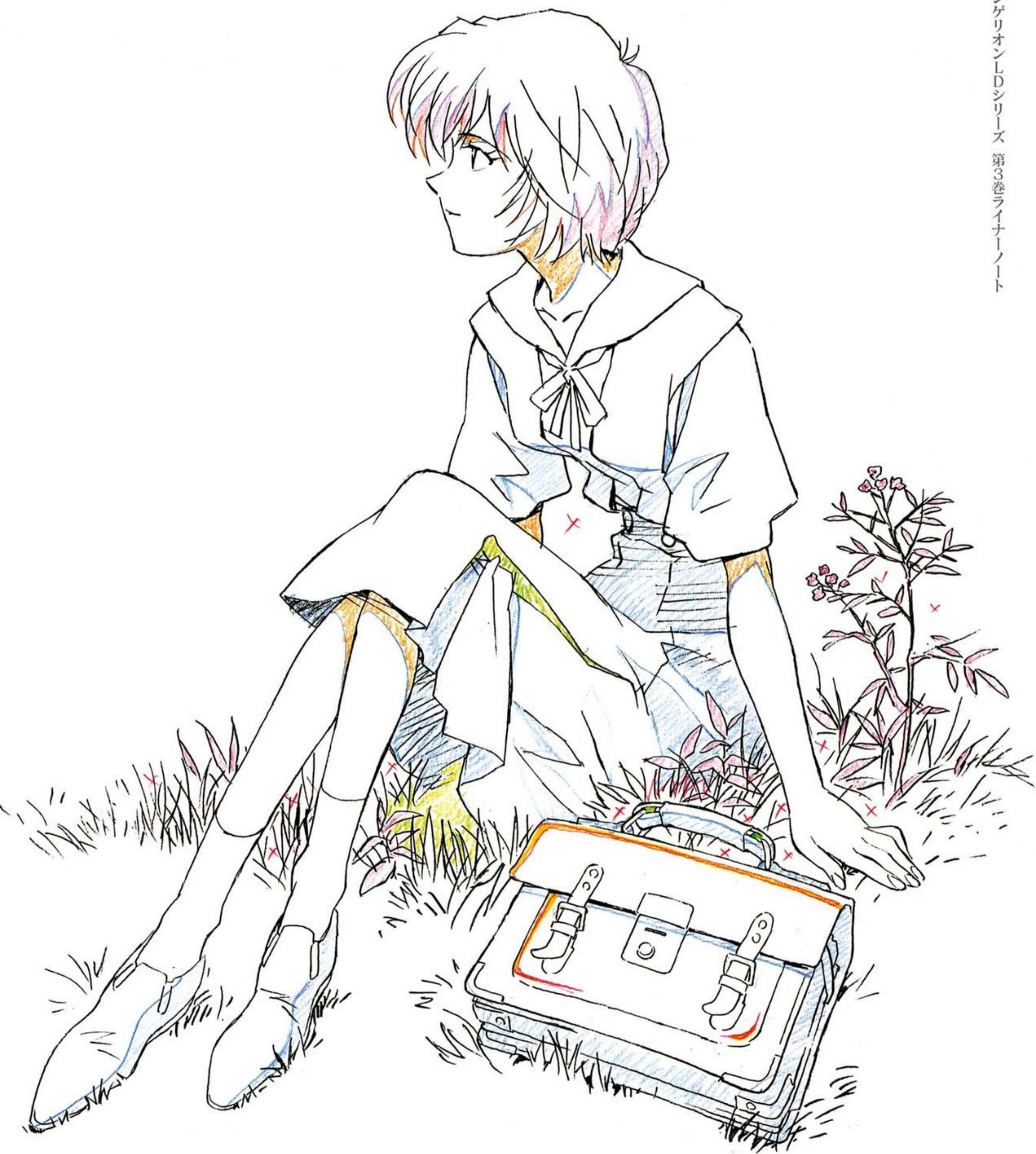





原画：本田 雄
初出：新世紀エヴァンゲリオンLDシリーズ
第4巻ライナーノート



初出：新世紀エヴァンゲリオンLDシリーズ第8巻ライナーノート
原画：本田 雄（原画所在不明のため、線画コピーを掲載）

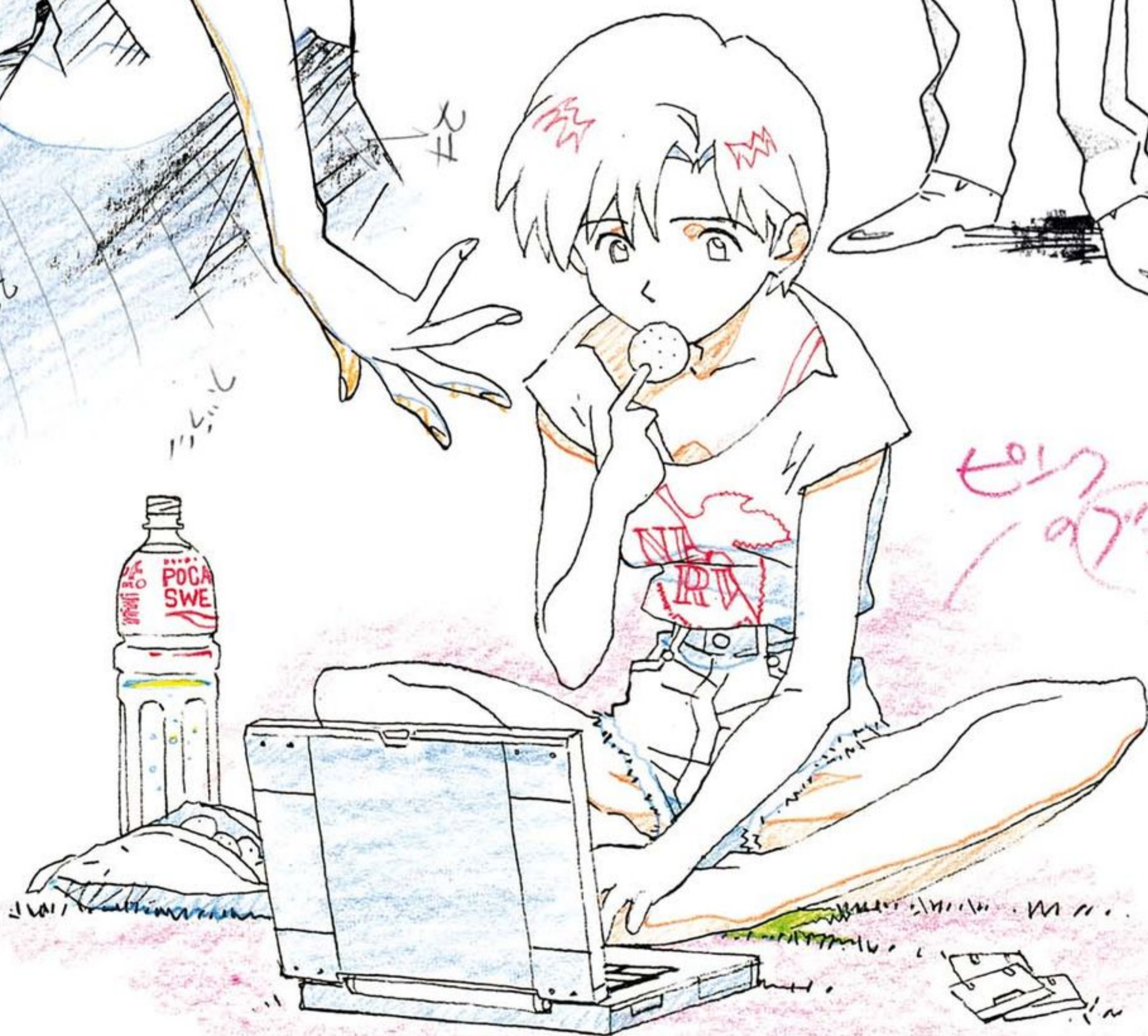

原画：本田 雄
初出：新世紀エヴァンゲリオンLDシリーズ
第7巻ライナーノート



原画: 本田 雄
初出: 新世紀エヴァンゲリオンLDシリーズ
第10巻ライナーノート

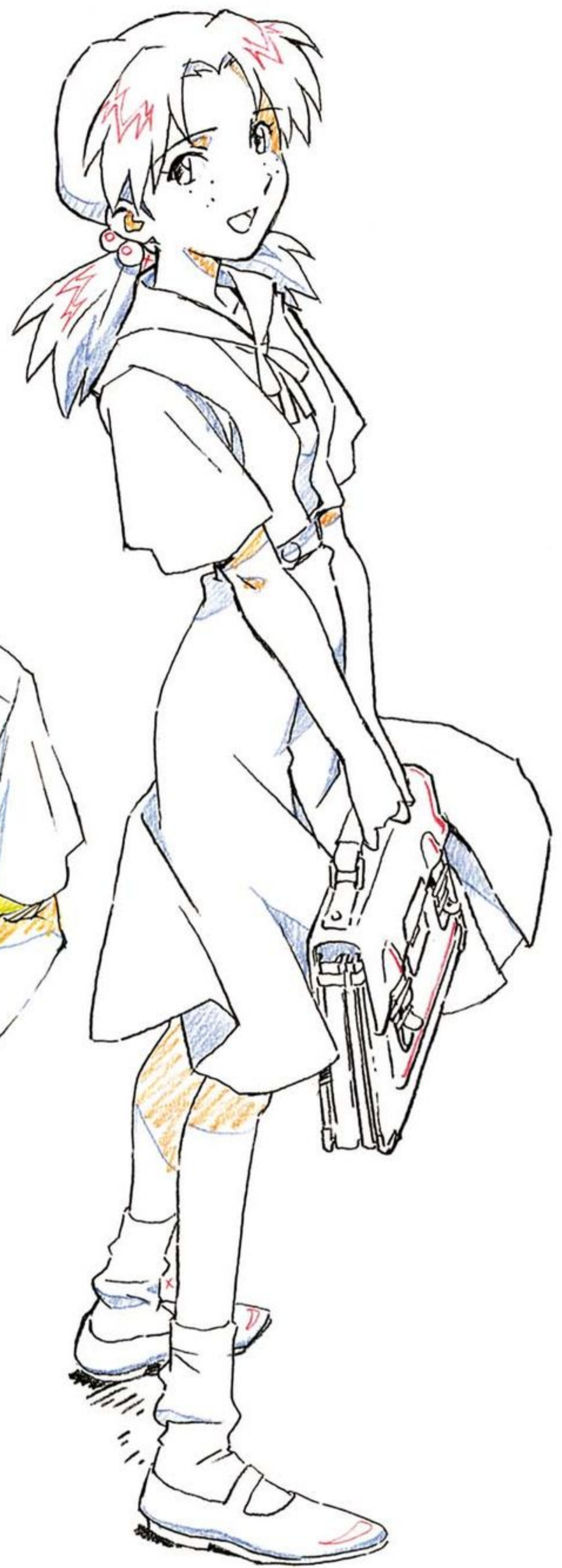

原画: 本田 雄
初出: 新世紀エヴァンゲリオンLDシリーズ
第9巻ライナーノート

原画: 本田 雄
初出: 新世紀エヴァンゲリオンLDシリーズ
第1巻ライナーノート

Hi

原画: 本田 雄
初出: 新世紀エヴァンゲリオンLDシリーズ
第6巻ライナーノート



原画: 本田 雄
初出: 新世紀エヴァンゲリオンLDシリーズ 第11巻ライナーノート

Groundwork of EVANGELION The Movie2

はじめに、そしておわりに。

本作品が終局を迎え、すでに4年。

本原画集の企画を立ち上げ、すでに1年半。

こうして、また違った形の終局を味わうのは、ただ感無量です。

今、自分から述べる言葉はひとつしかありません。

ありがとうございました。

本巻では、現存する原画を可能な限り回収し、その中から劇場版26話を選出し、紙面の許す限り載せております。

しかし、すでに所在不明の原画が多々ありその全てを掲載することは物理的に不可能でした。申し訳ありません。

なお、作画監督による修正原画は、その目的から完成したセル画より線が足りない部分もありますが、これらは部分修正によるもので、決して線が抜けているわけではありませんので、あしからず。

また、一部の原画に関しては、原画と修正原画を併載してあります。これは作画監督の仕事の一部を紹介するという意図によるもので、その原画に何か問題があるという事等ではありません。他意の無きものです。

そして、レイアウトやタイムシート、当時の作画用設定資料等も参考になればと、一部掲載してあります。

あと、いかんせん、月日が経っている為、生原画の保存状態の問題やオリジナル散逸によりやむなくコピー紙から収録した原画等にあたっては、可能な限り修正いたしましたが、多少の御見苦しい点は、御容赦下さい。

今、また改めて劇場版、及び編集スタッフに心から感謝いたします。

本当に、お疲れ様でした。

本当に、ありがとうございました。

そして『エヴァ』原画集も本巻にて、ついに終了いたします。

これもまた全て、皆様のおかげです。

改めて、お礼申し上げます。

本当に、ありがとうございました。

庵野秀明
2001/11/30



#26-C001



A1
B1
C1

奥の髪はAで

#26-C007



A0

#26-C009



A1
 A2
 A3
 A4
 A5
 A6
 A7
 A8
 A9
 A10
 A11
 A12
 A13
 A14
 A15
 A16
 A17
 A18
 A19
 A20
 A21
 A22
 A23
 A24
 A25
 A26
 A27
 A28
 A29
 A30
 A31
 A32
 A33
 A34
 A35
 A36
 A37
 A38
 A39
 A40
 A41
 A42
 A43
 A44
 A45
 A46
 A47
 A48
 A49
 A50
 A51
 A52
 A53
 A54
 A55
 A56
 A57
 A58
 A59
 A60
 A61
 A62
 A63
 A64
 A65
 A66
 A67
 A68
 A69
 A70
 A71
 A72
 A73
 A74
 A75
 A76
 A77
 A78
 A79
 A80
 A81
 A82
 A83
 A84
 A85
 A86
 A87
 A88
 A89
 A90
 A91
 A92
 A93
 A94
 A95
 A96
 A97
 A98
 A99
 A100

A22

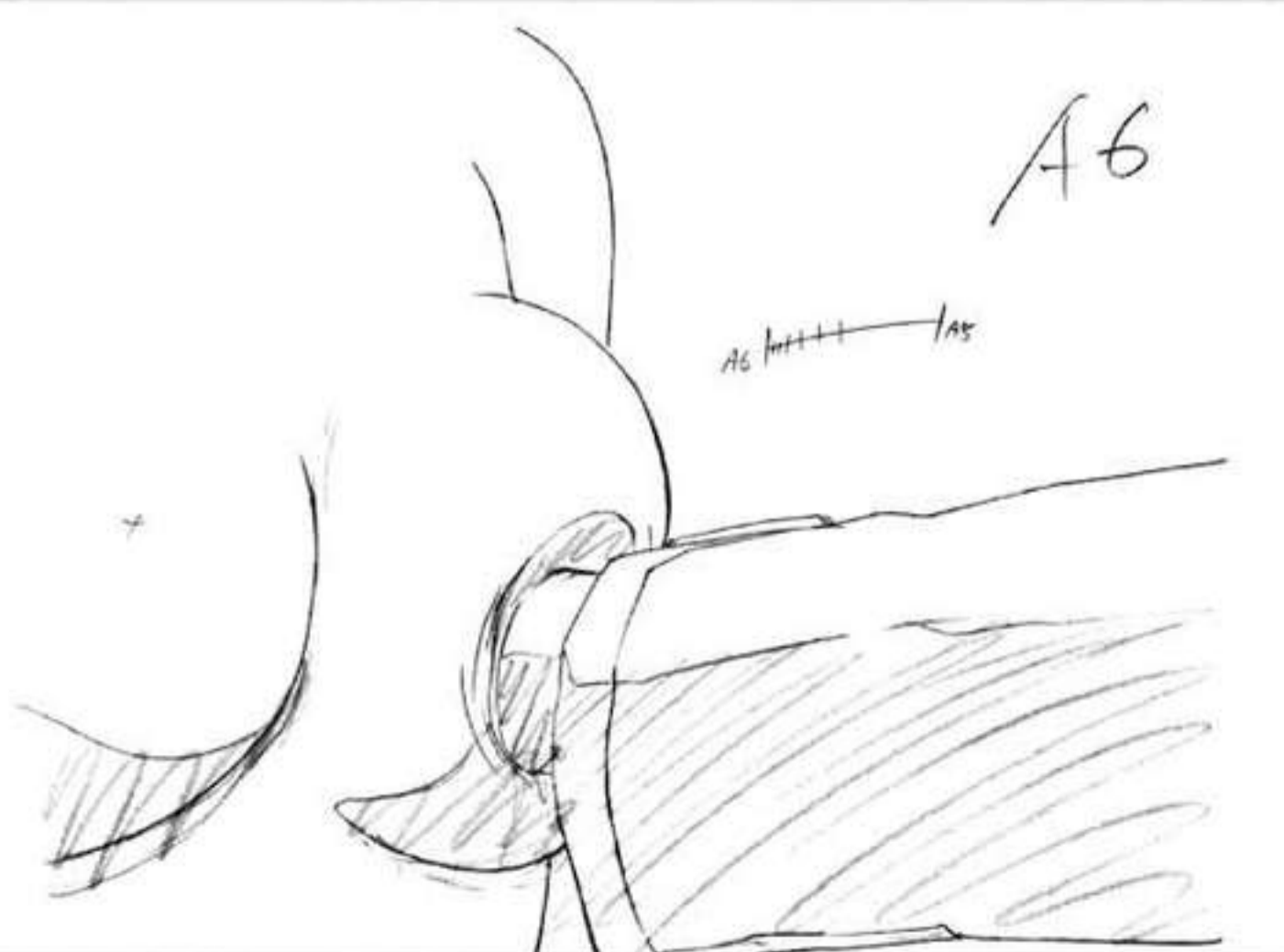
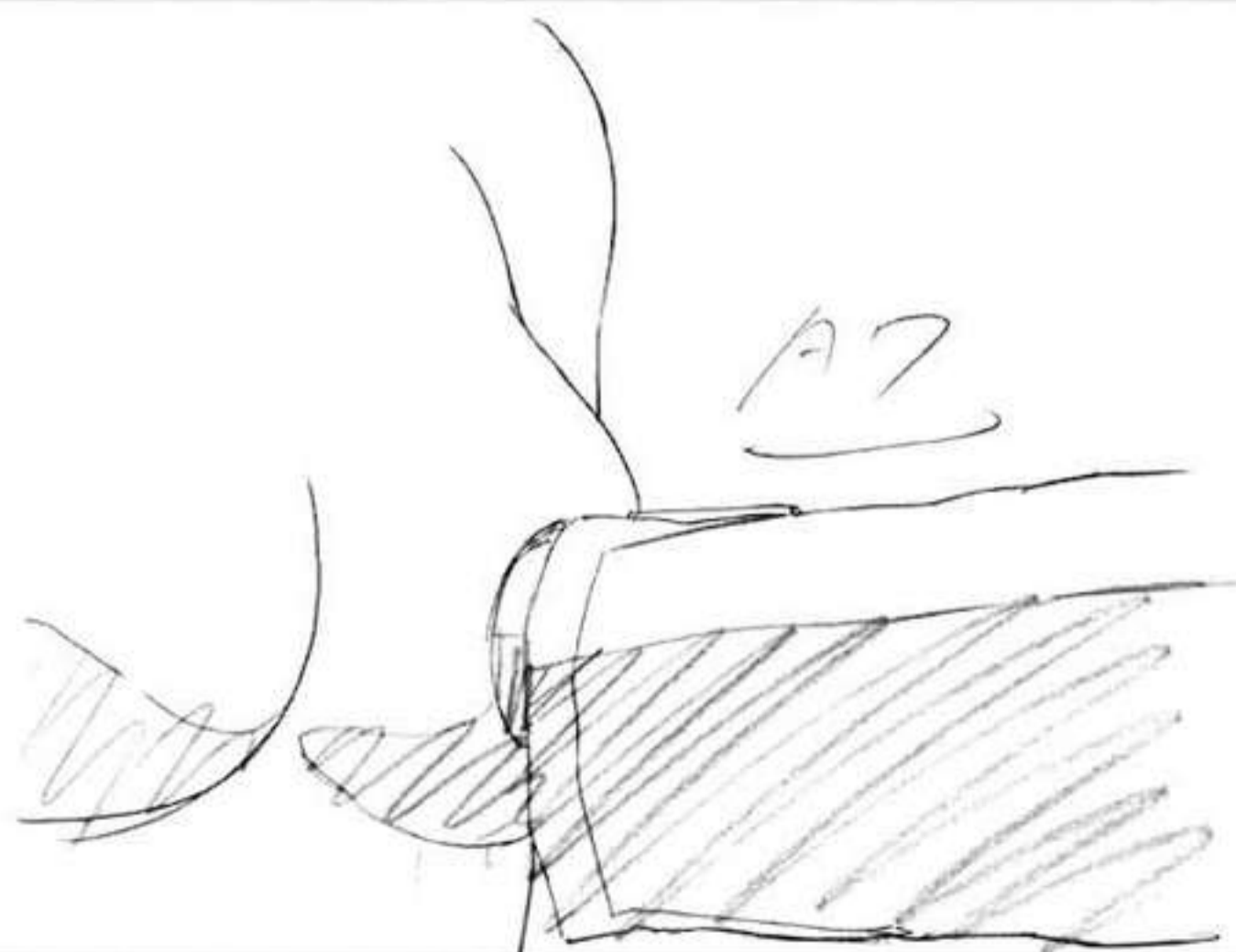
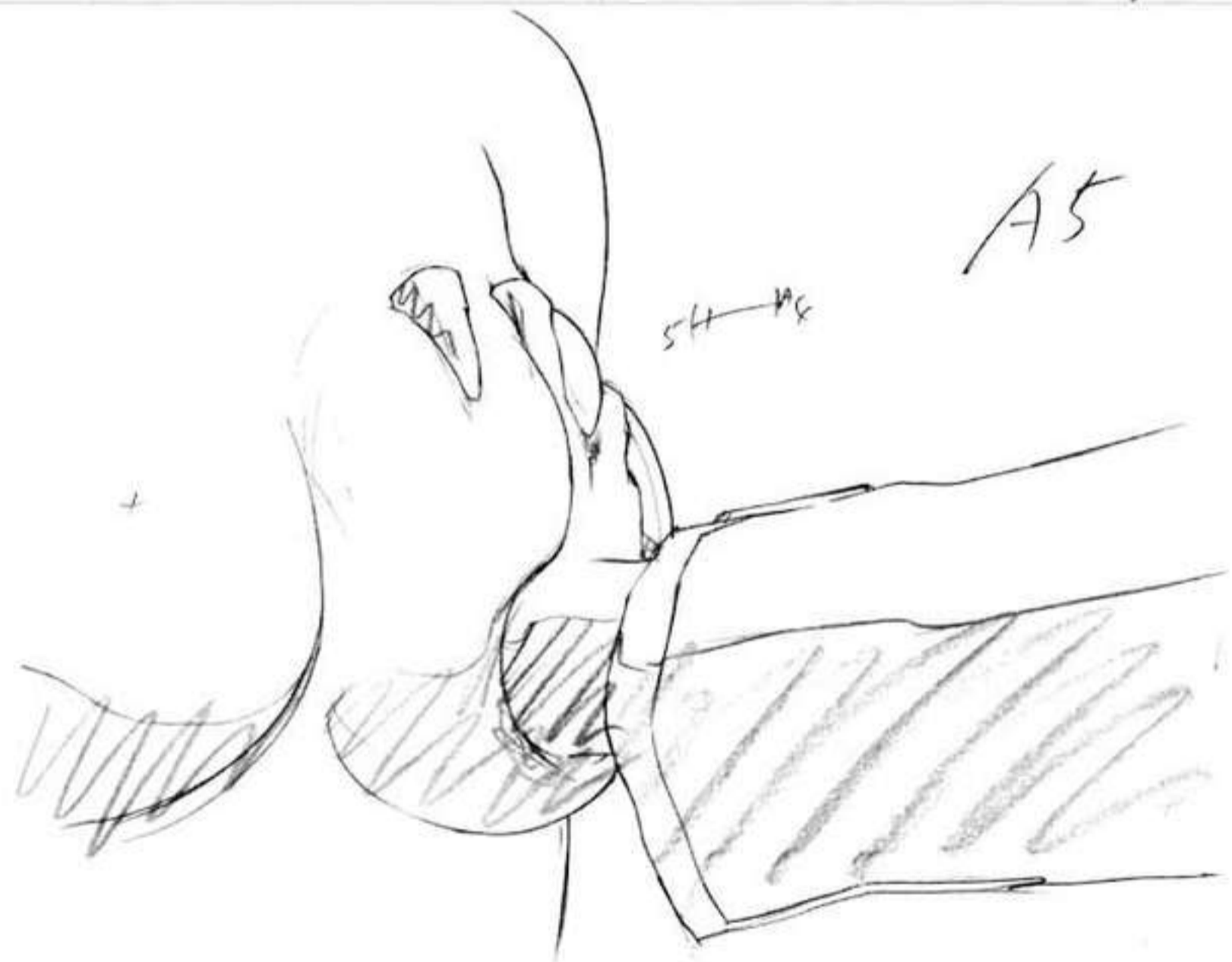
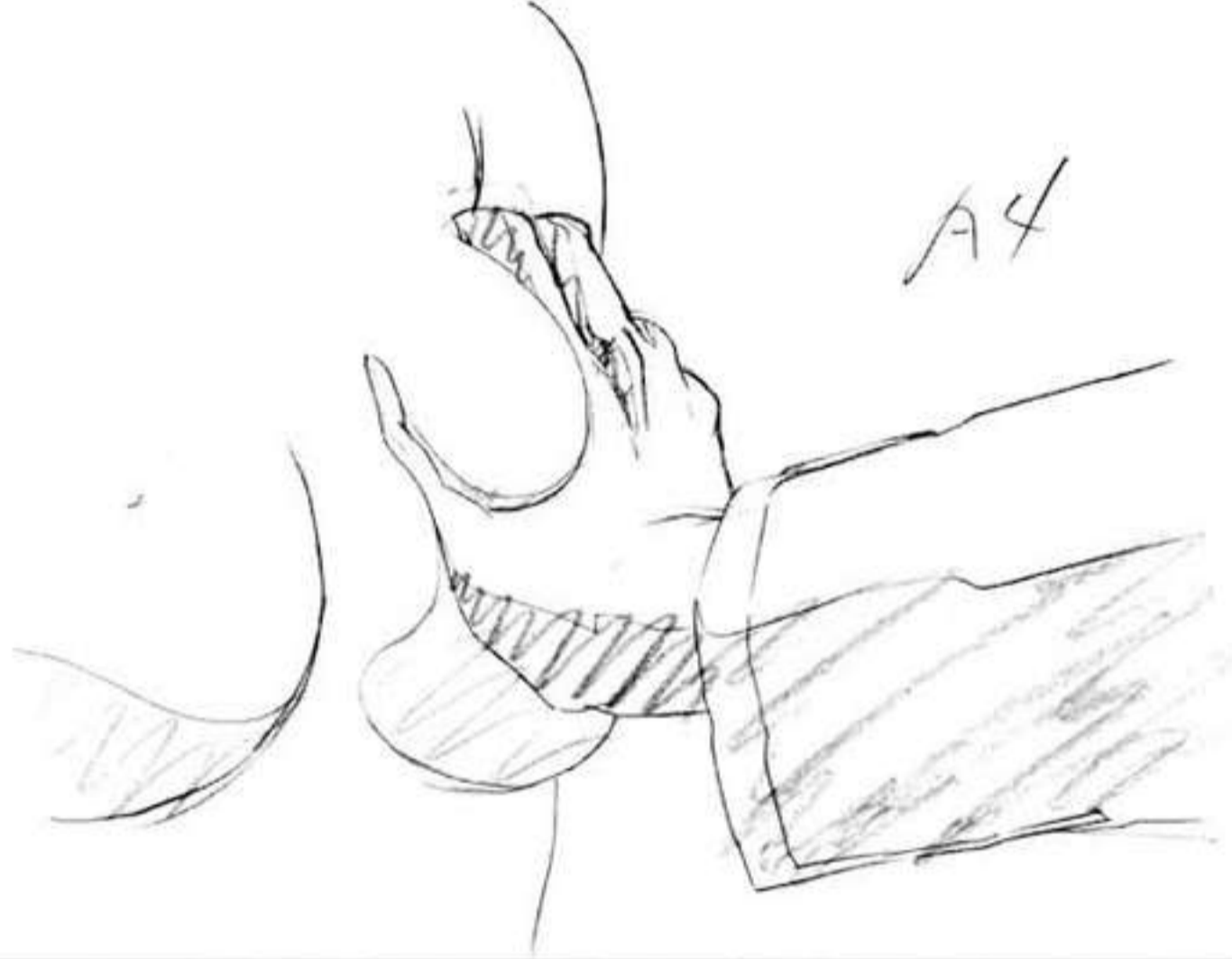
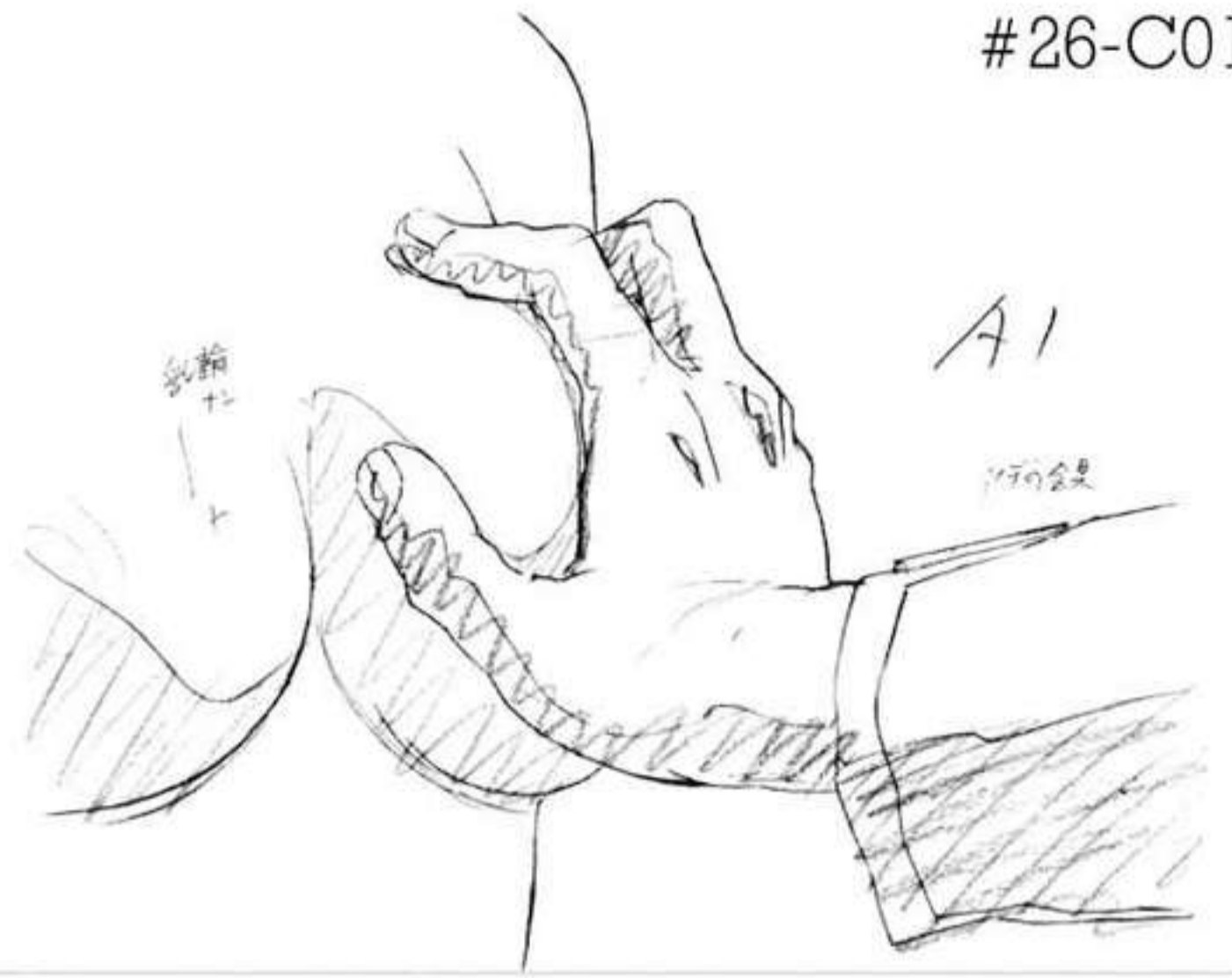
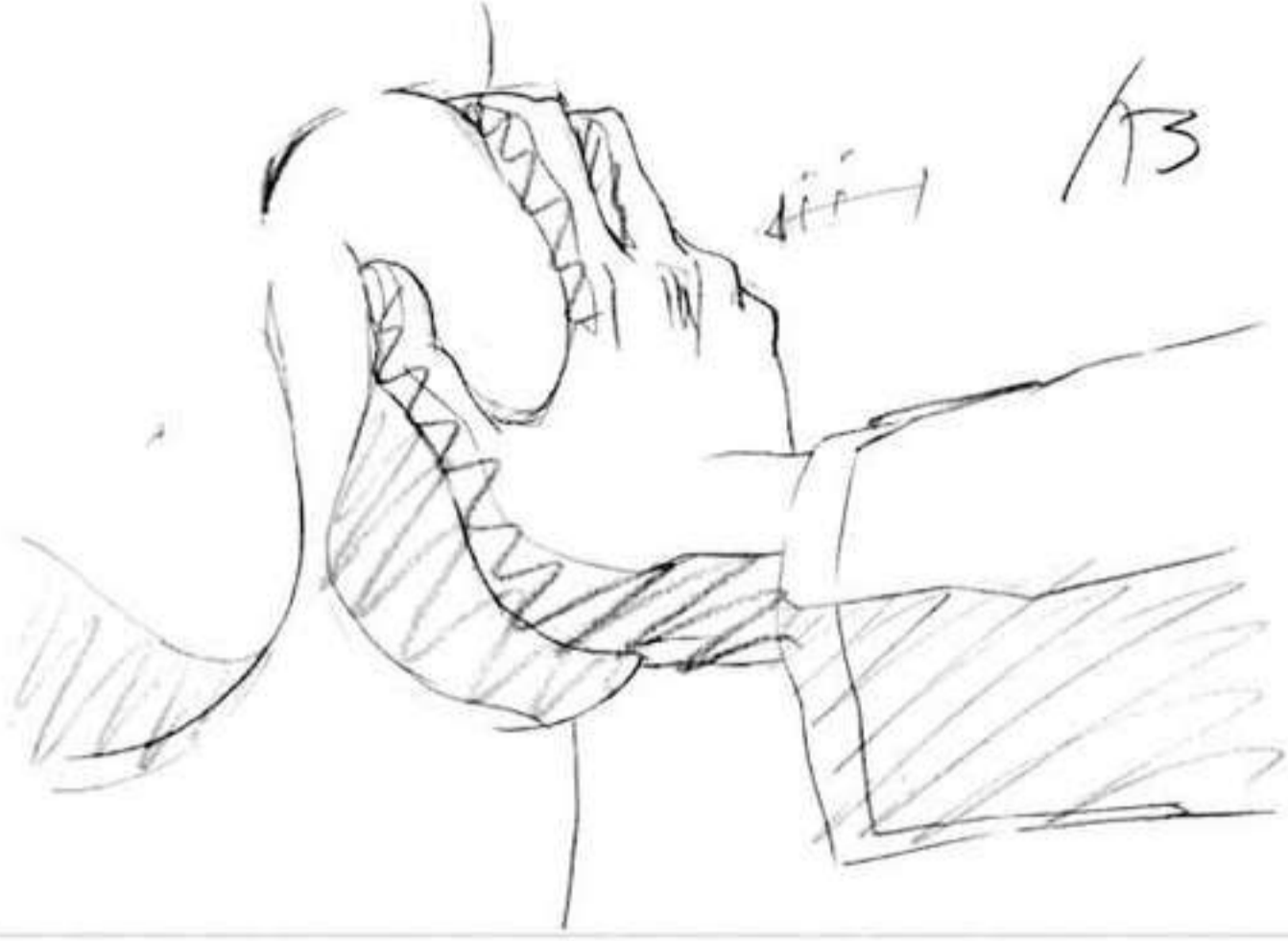



#26-C011

(A4) 12次

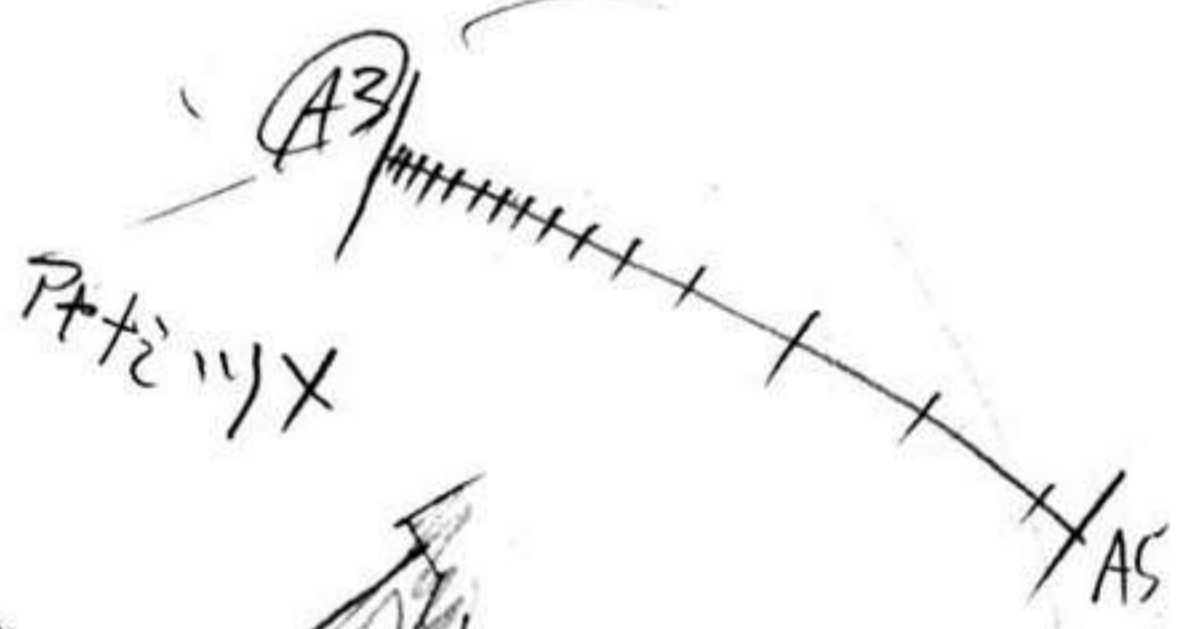

確は
均等7/11

12
AD
1/2



ア2
透かし



A1

走馬
B1

#26-C028

X2#

X2#

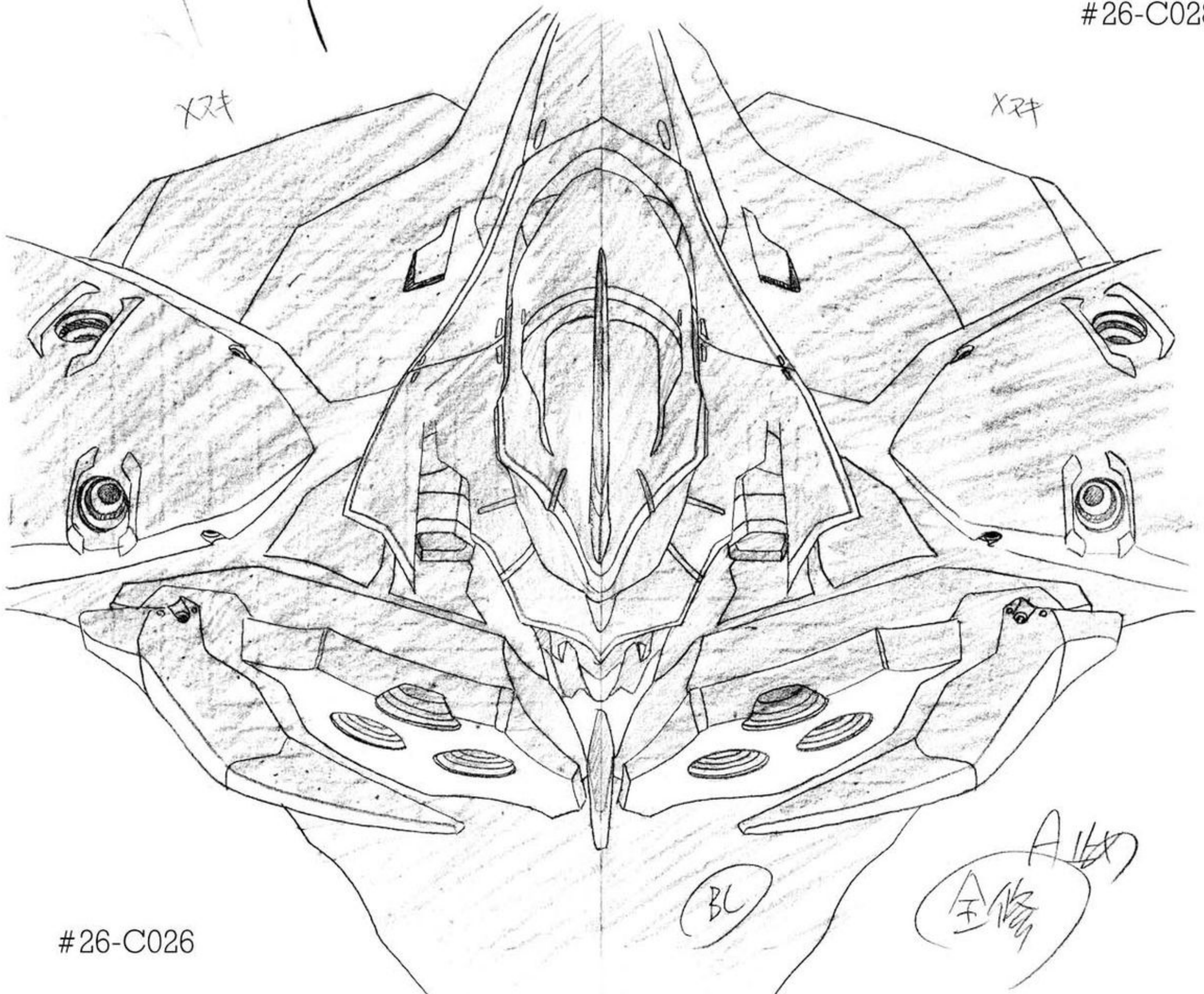

BC

A1#
全修

#26-C026

#26-C036

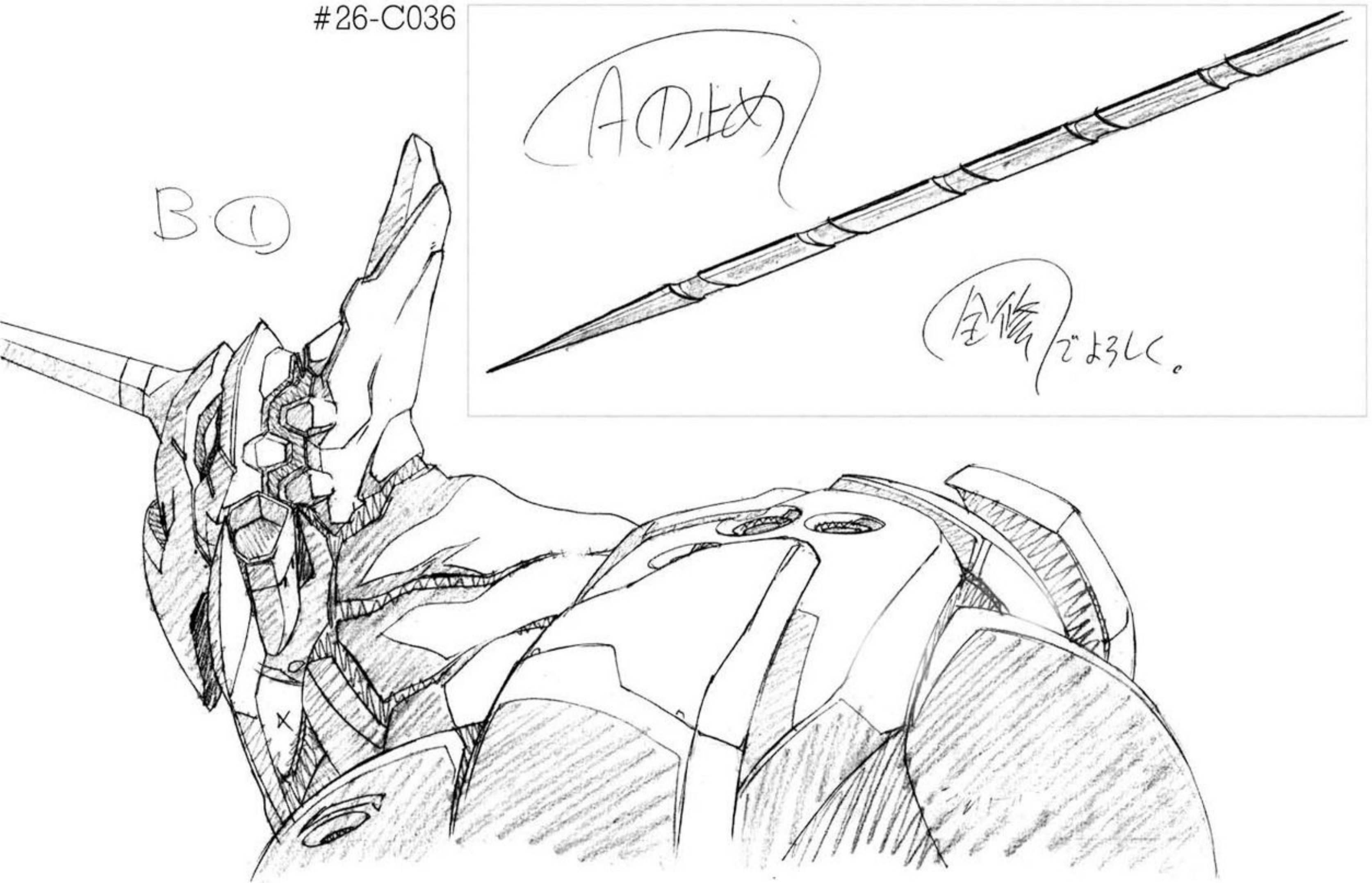

#26-C047



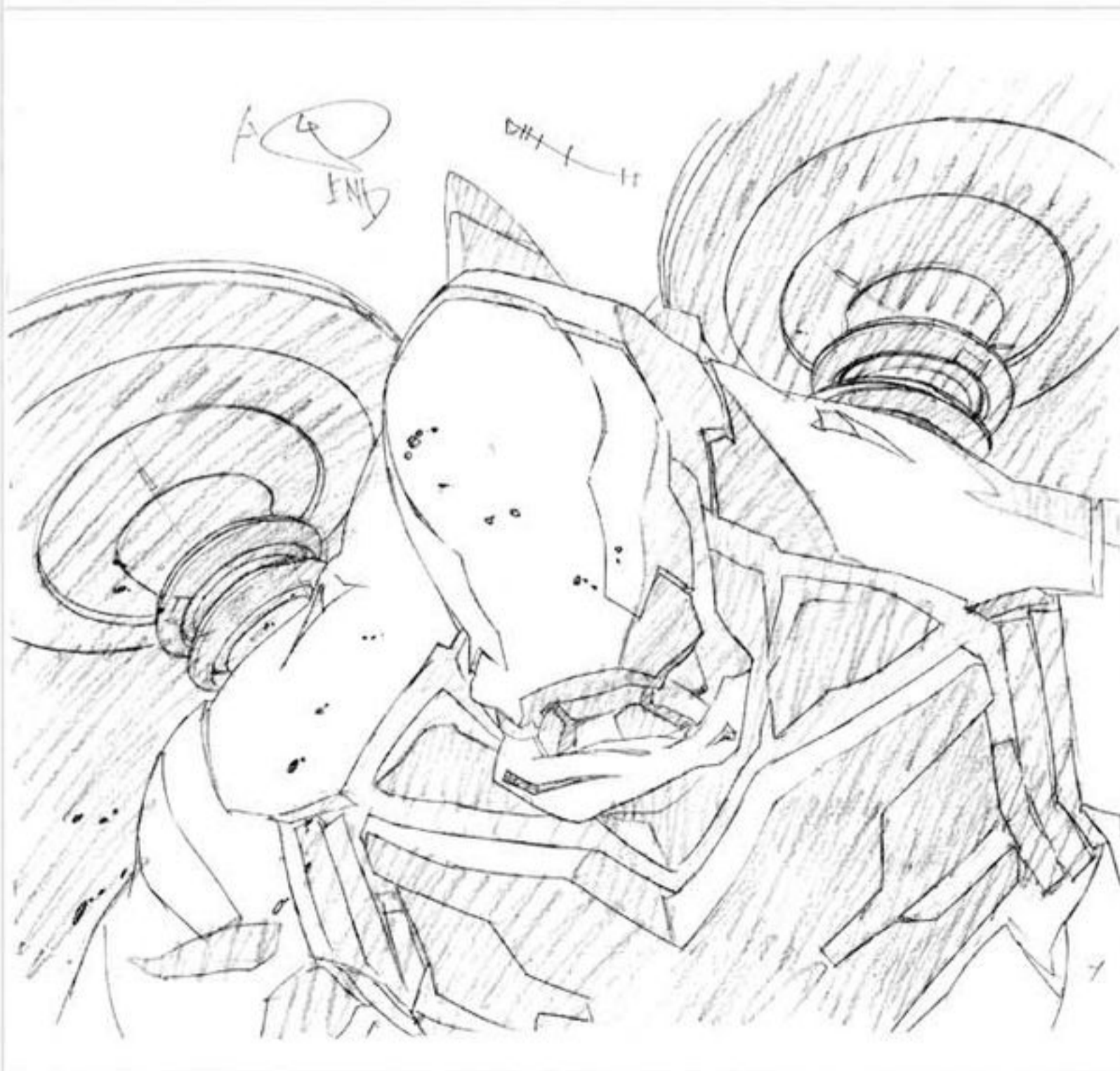

661
A (1)
2
3

表情
(B1)

歯



#26-C052, 165

全修
A1
(B1)
661
C(1)
2
3

7-10
2
(44e)



#26-C063, 149

2x
C1

117
D1
2
3



A1
#26-C067

B1
1
7
C

#26-C089
レイアウト時作監修正



かたも
正対していい
いいと思っますか...
これでよろしく

修正原画

#26-C093

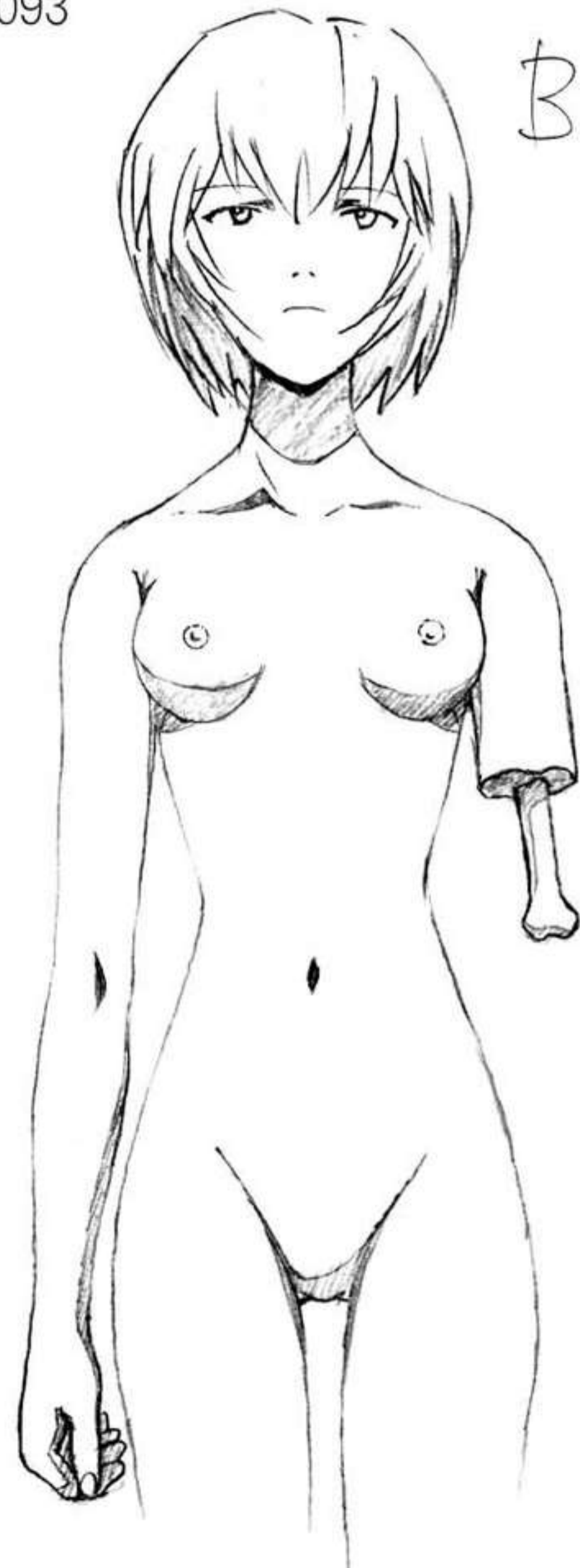
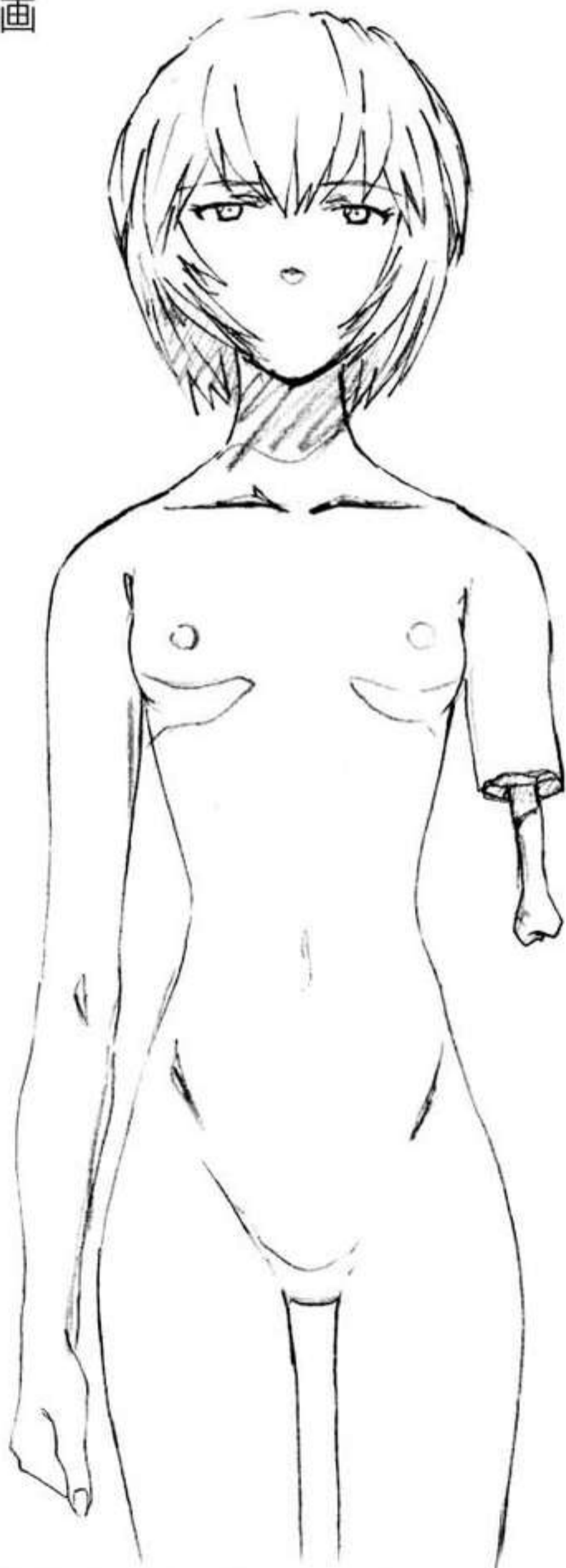

B1
修正
C093





修正原画

#26-C100

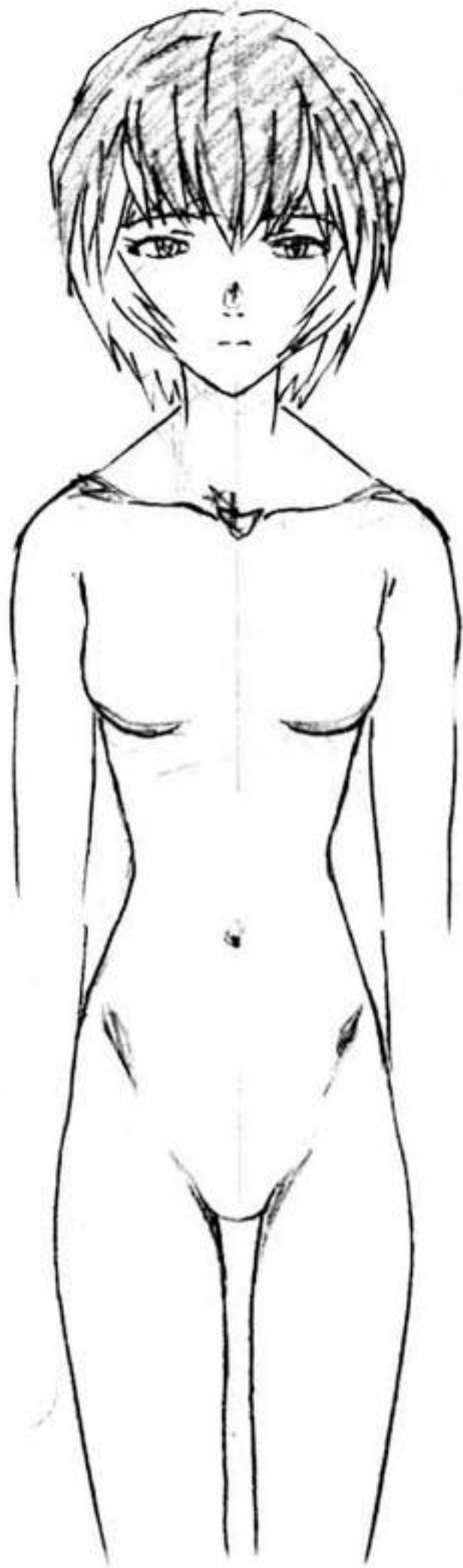

A1
修

カケ
修の子

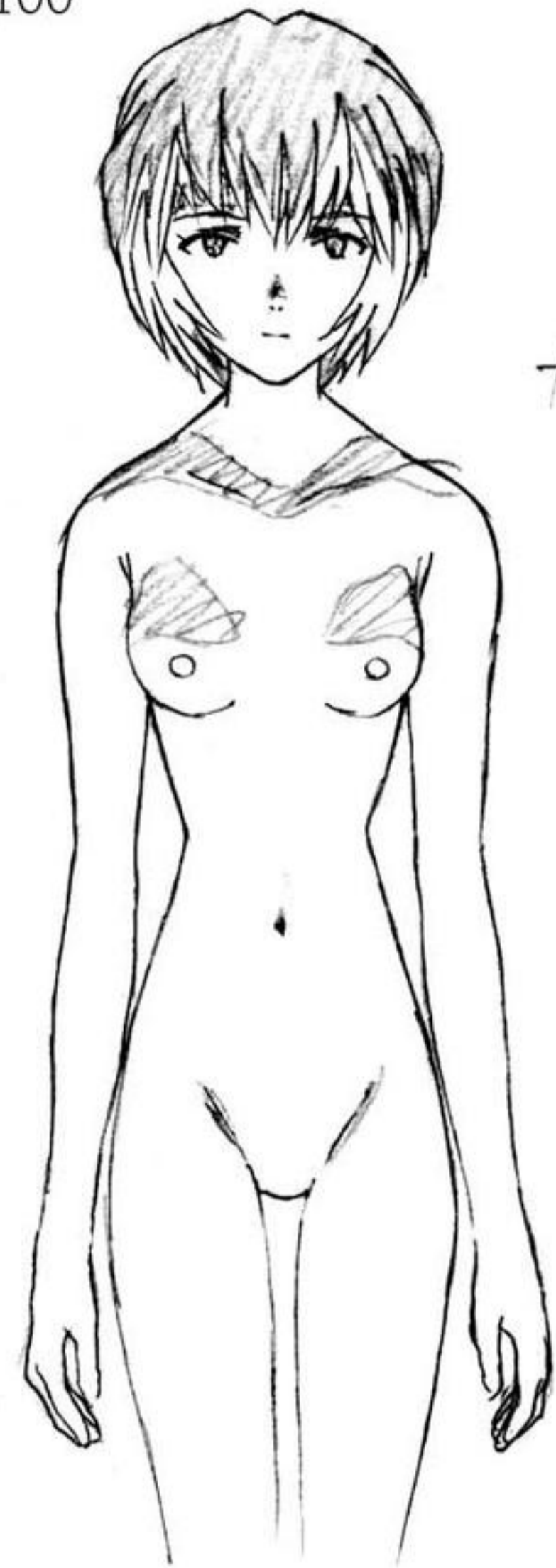

A1X

修正原画

#26-C102
A止め



#26-C098



A1
127



A1
修

#26-C110

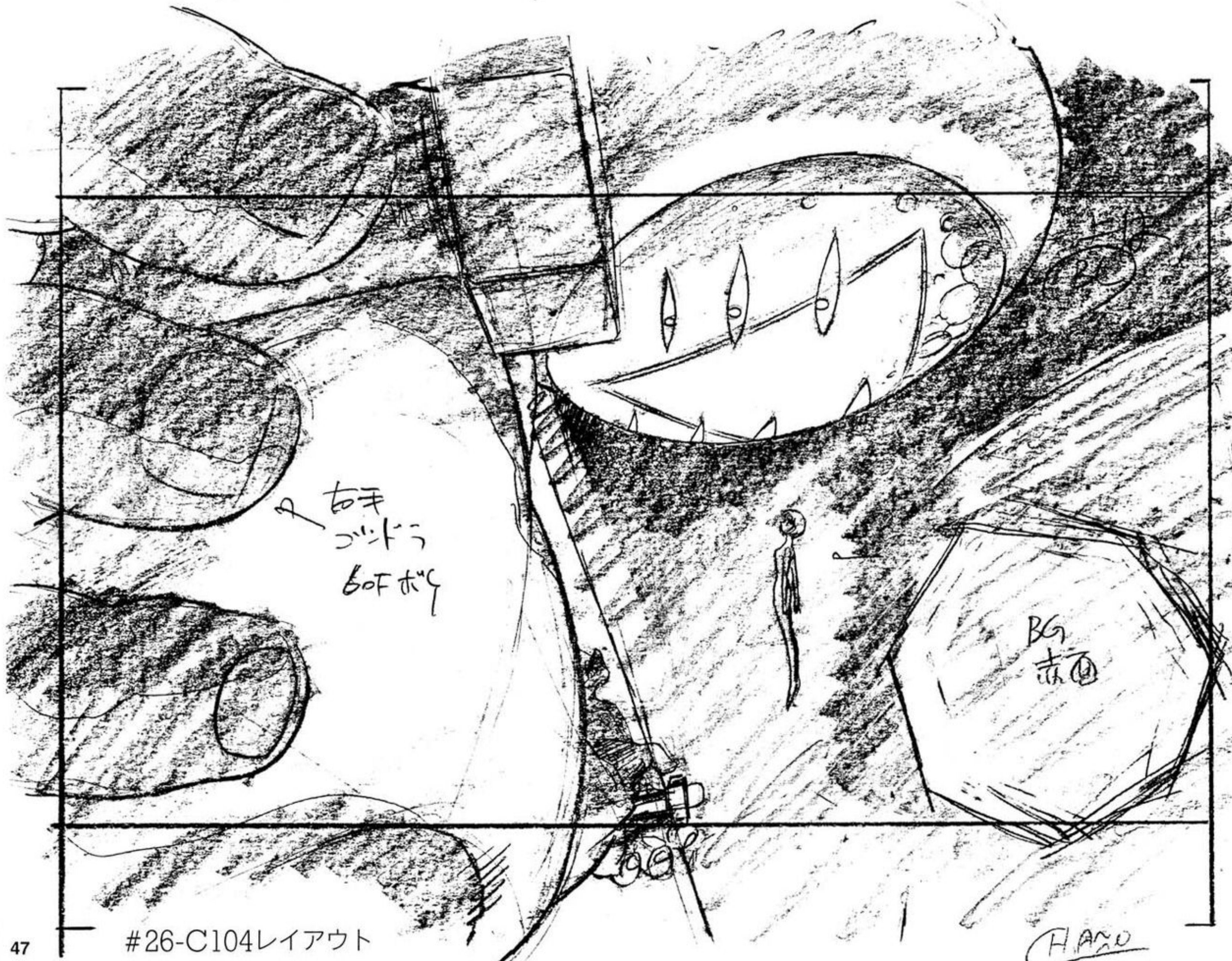

右
ゴッド
ボフボフ

BG
赤面

2001

CHANO

#26-C104レイアウト



#26-C118



修正原画



修正原画

修正原画



#26-C120レイアウト

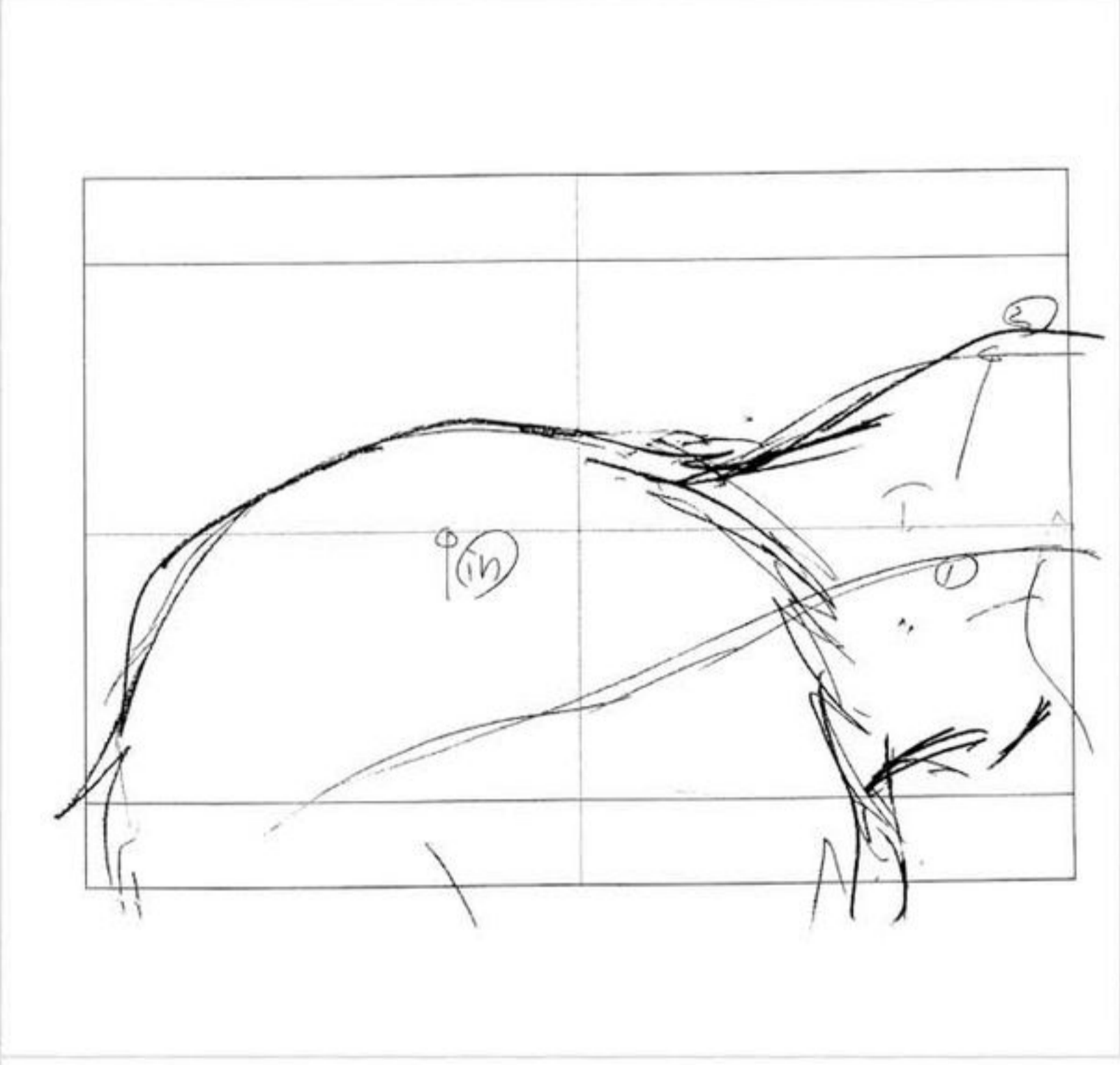



#26-C120



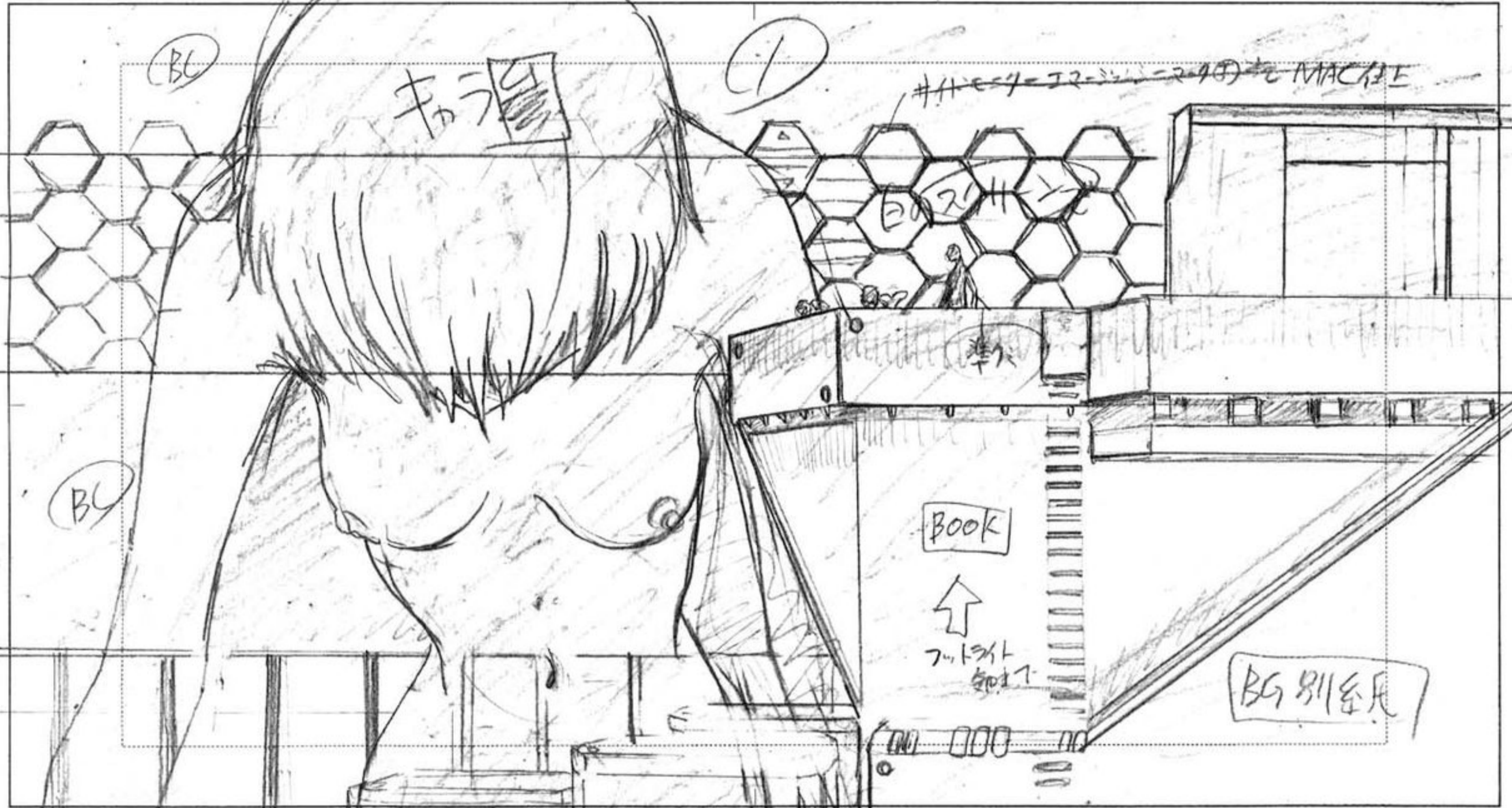

#26-C122レイアウト

#26-C122



(A) 1
 13

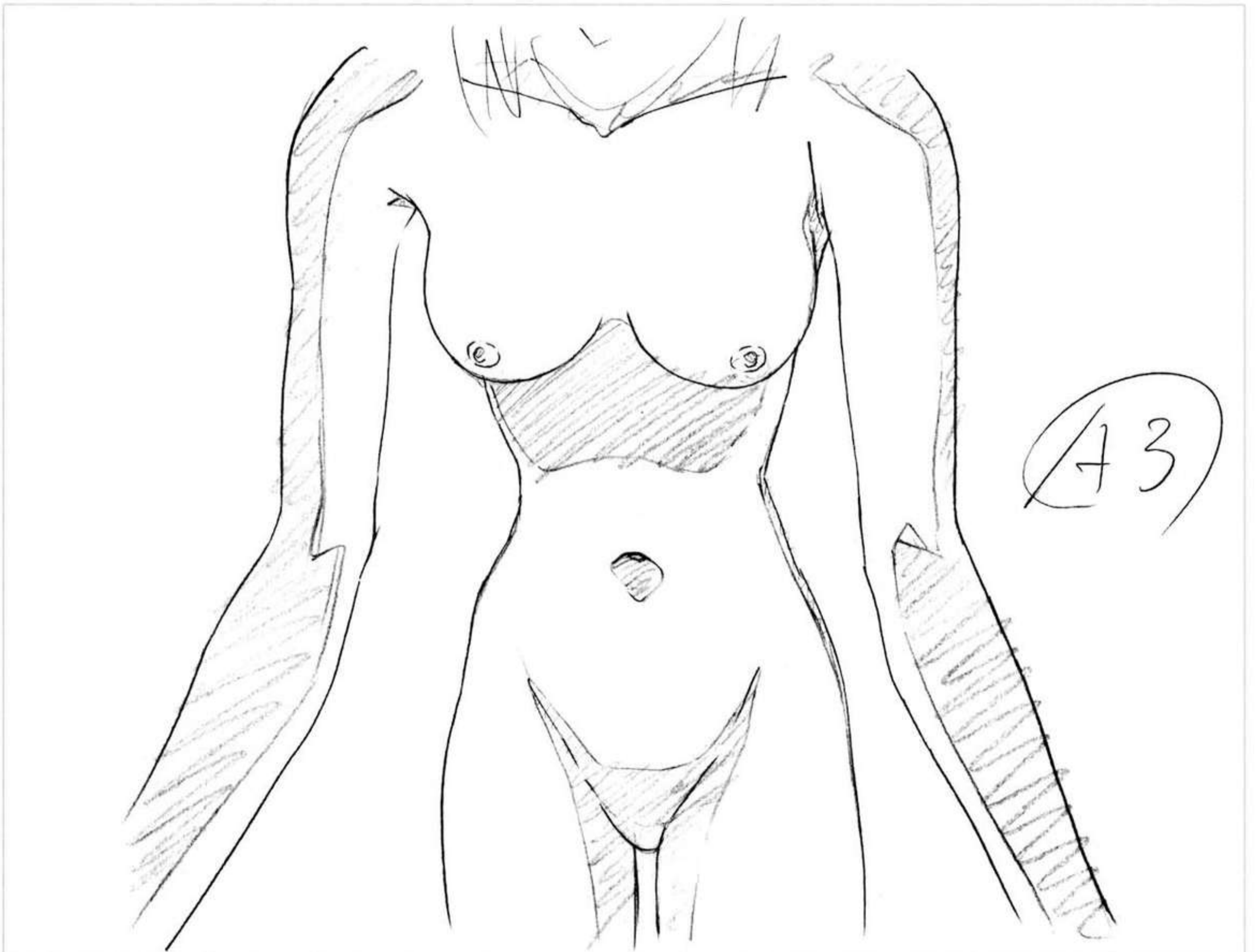
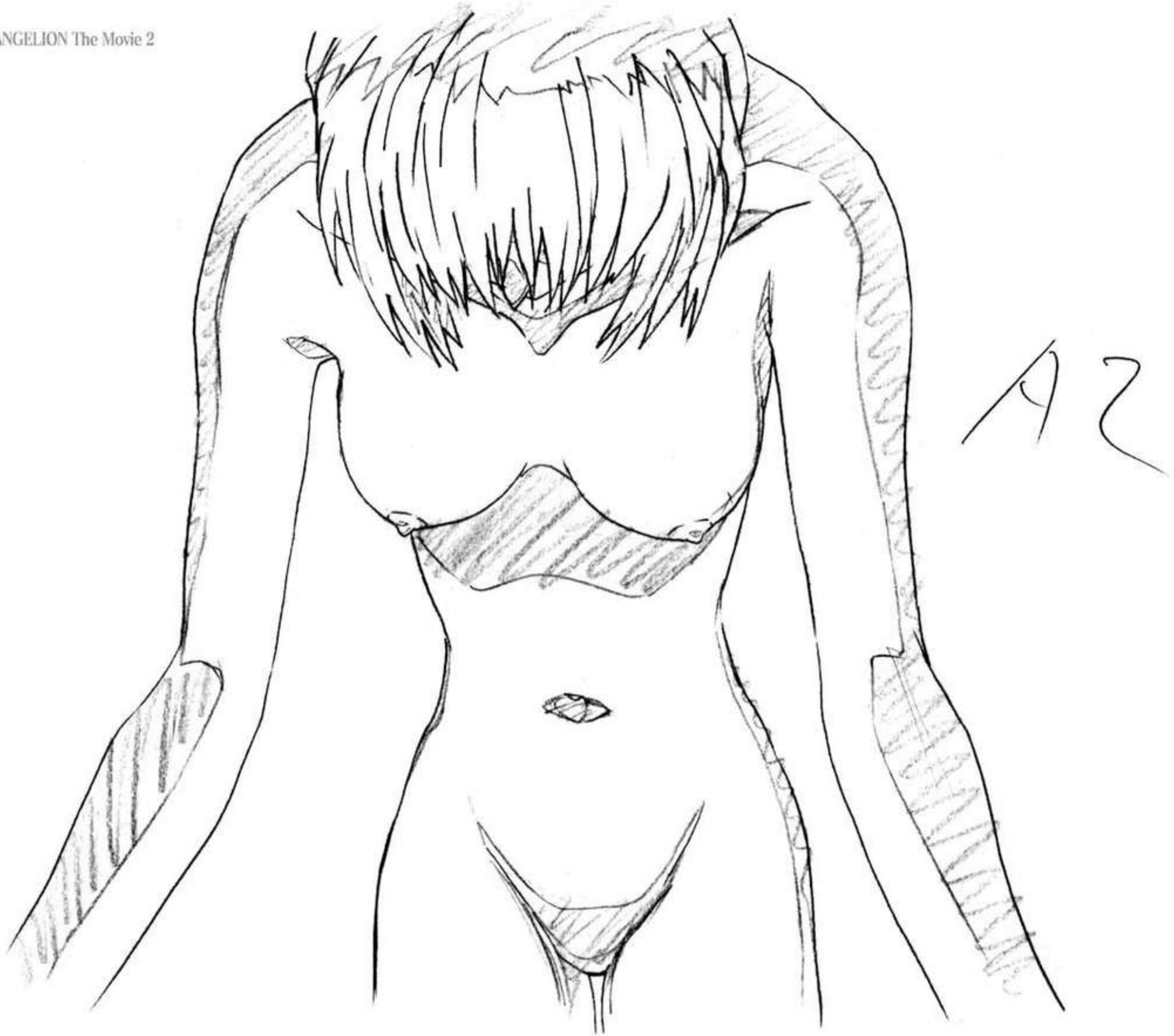





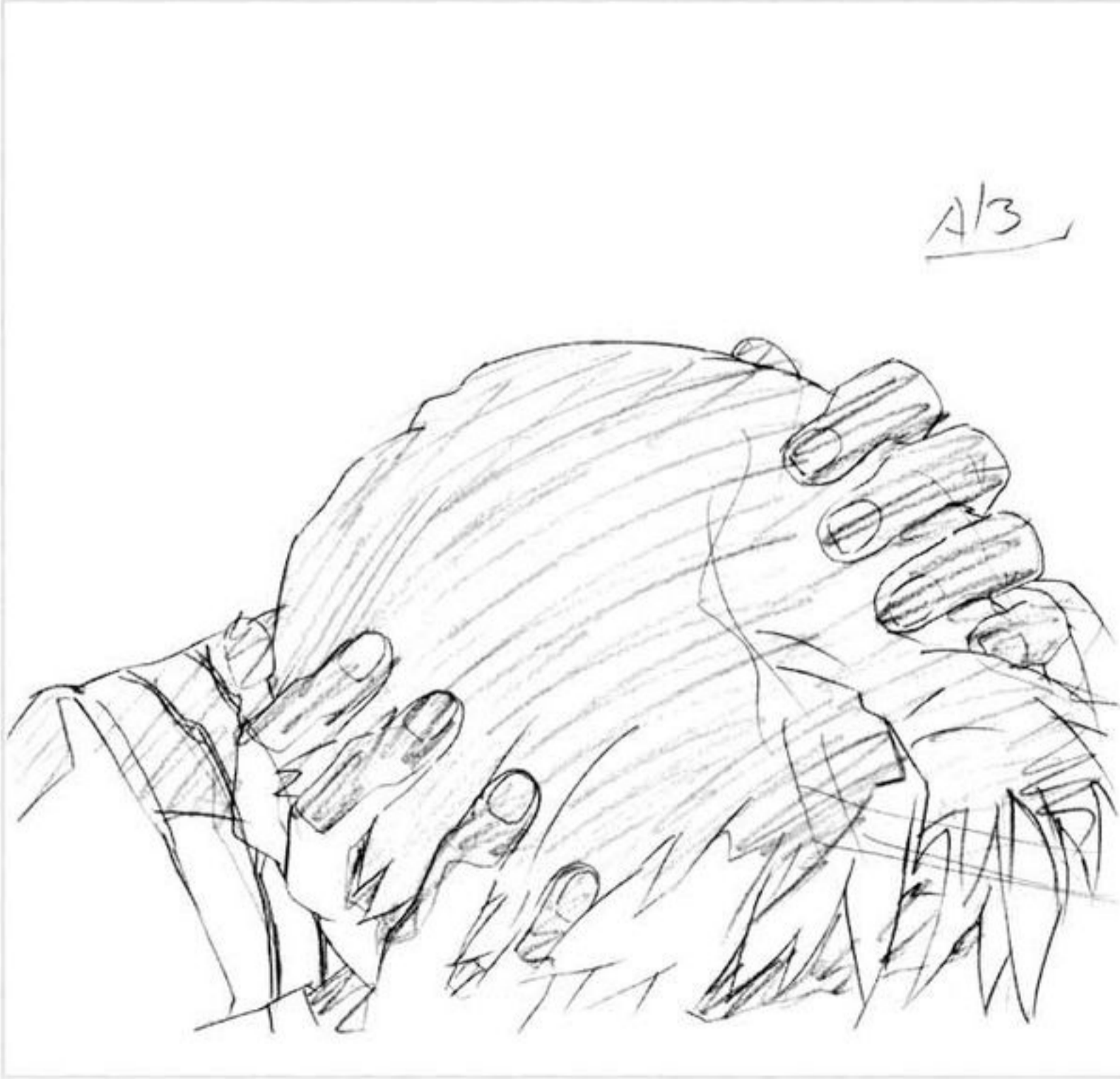
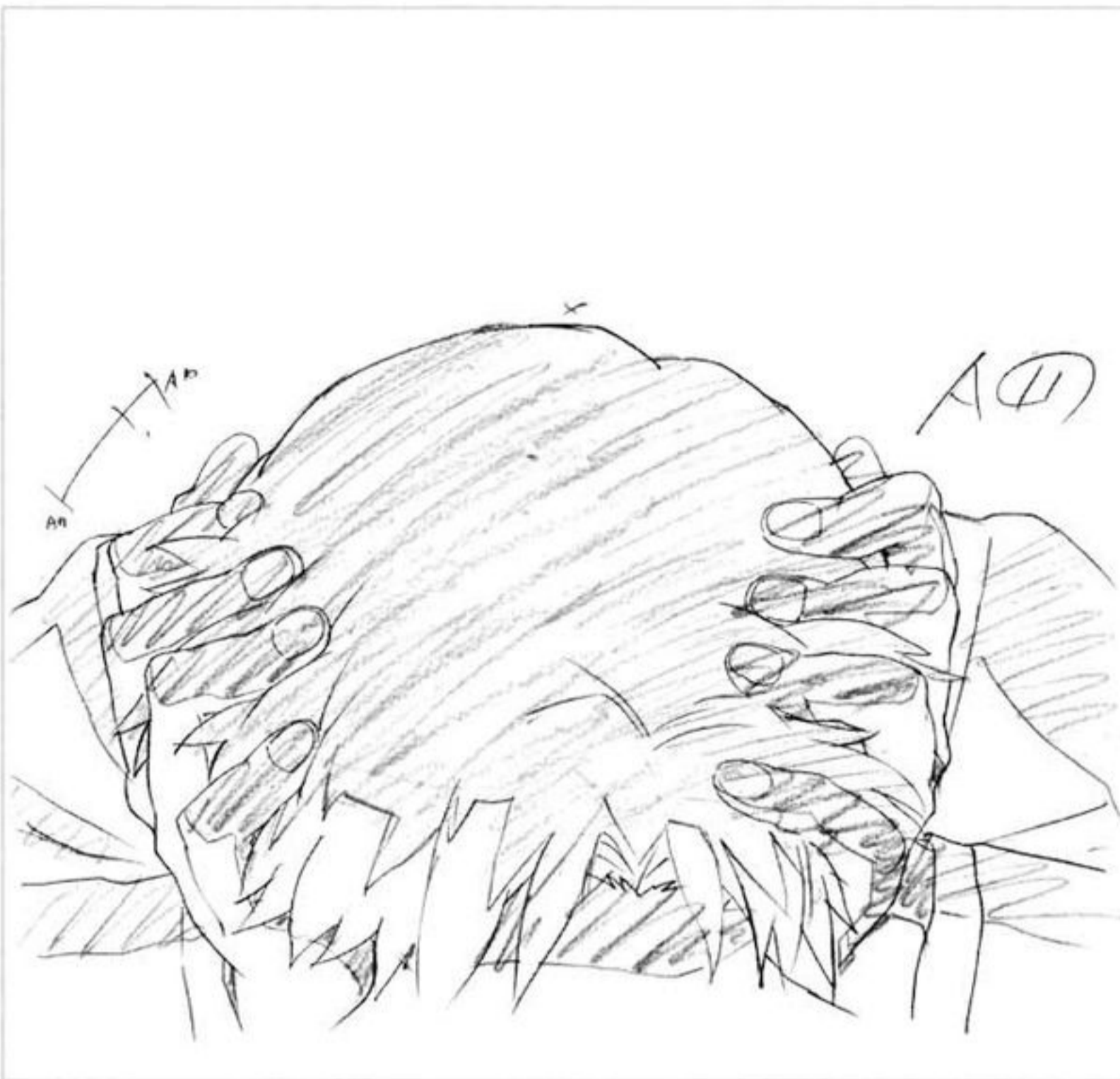

#26-C124C

トス可機

Alt
全機

動機、セキは、52
53C。

AI
修の修

1-210

#26-C128A

B(1) 1/3

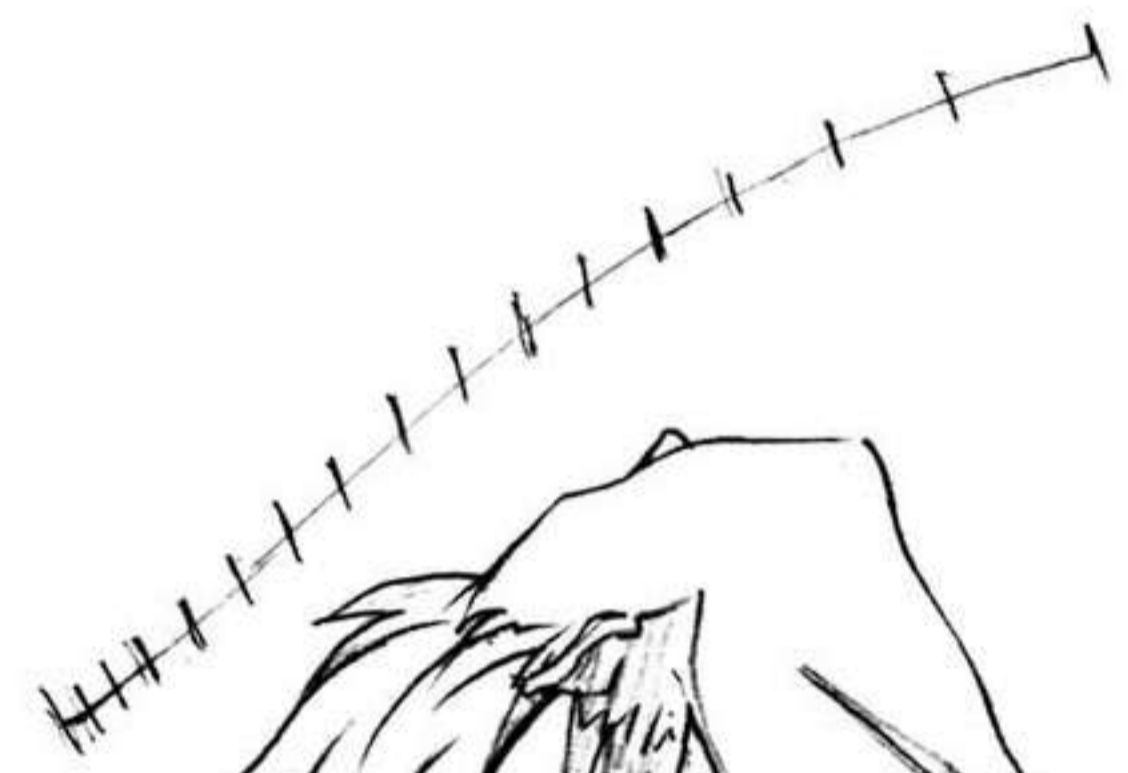
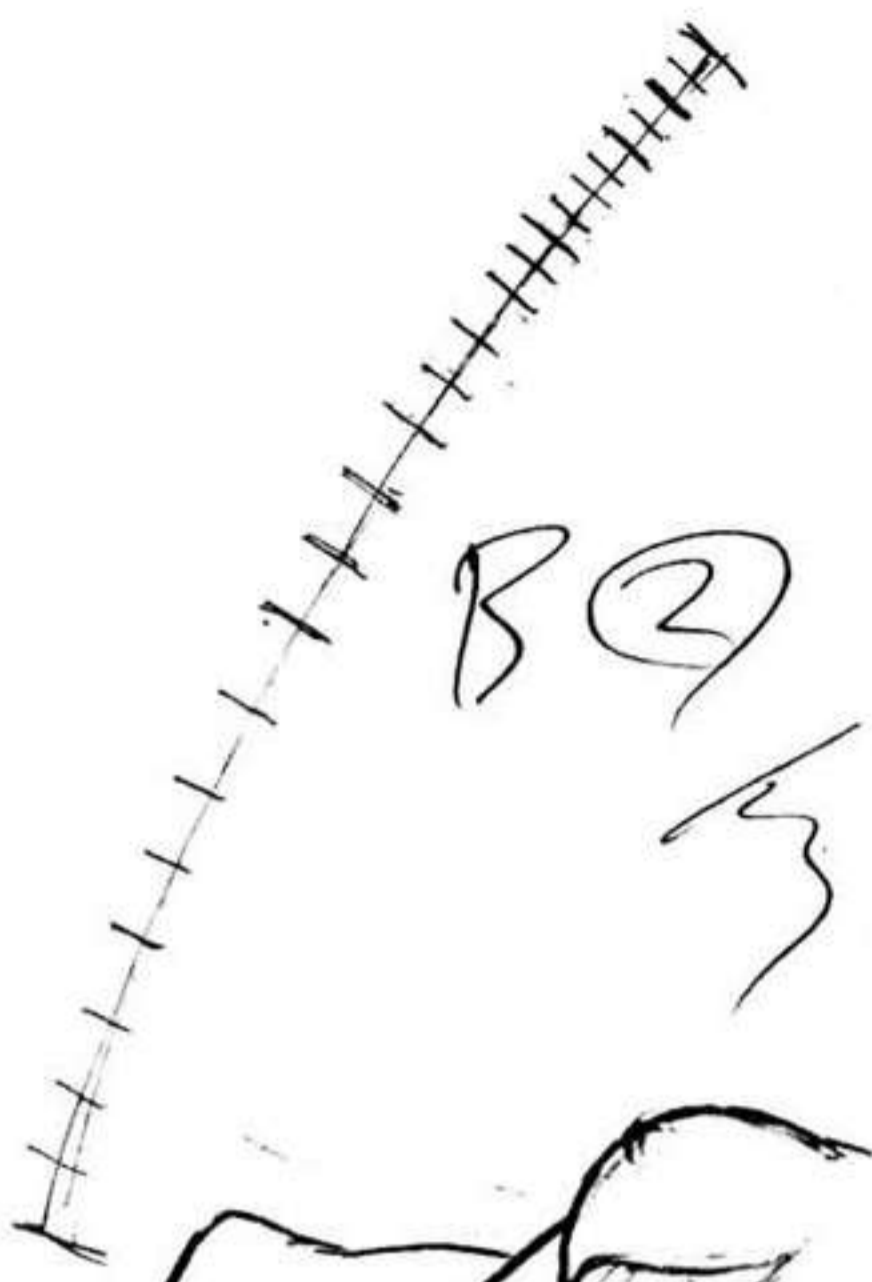

B(3) 1/3

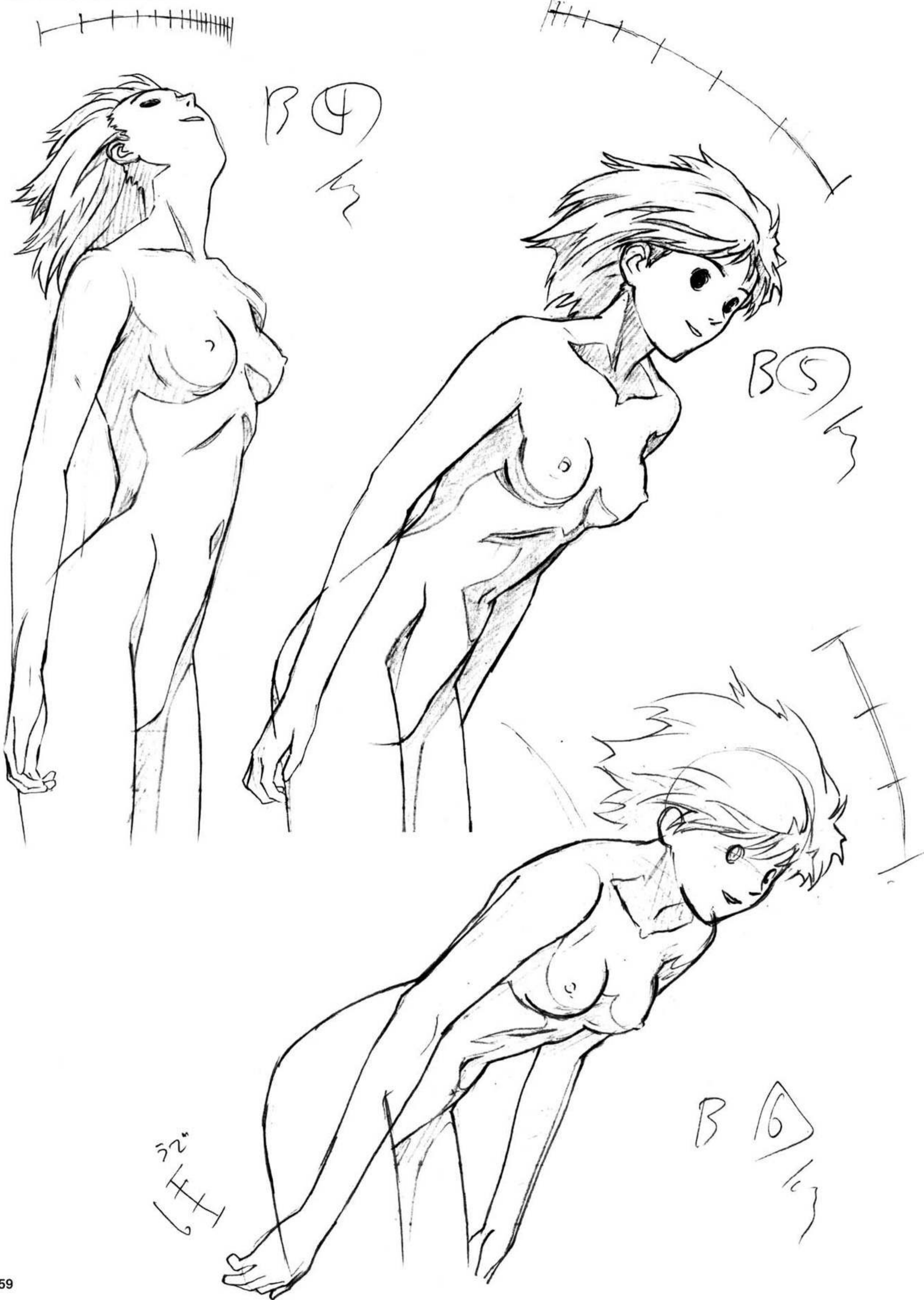



B(7)



H

B A

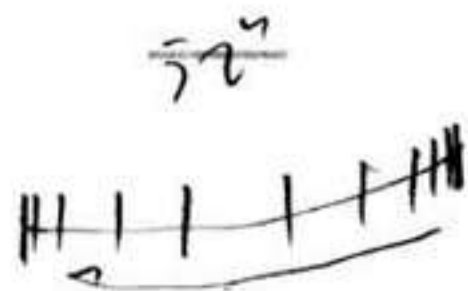

B(8)

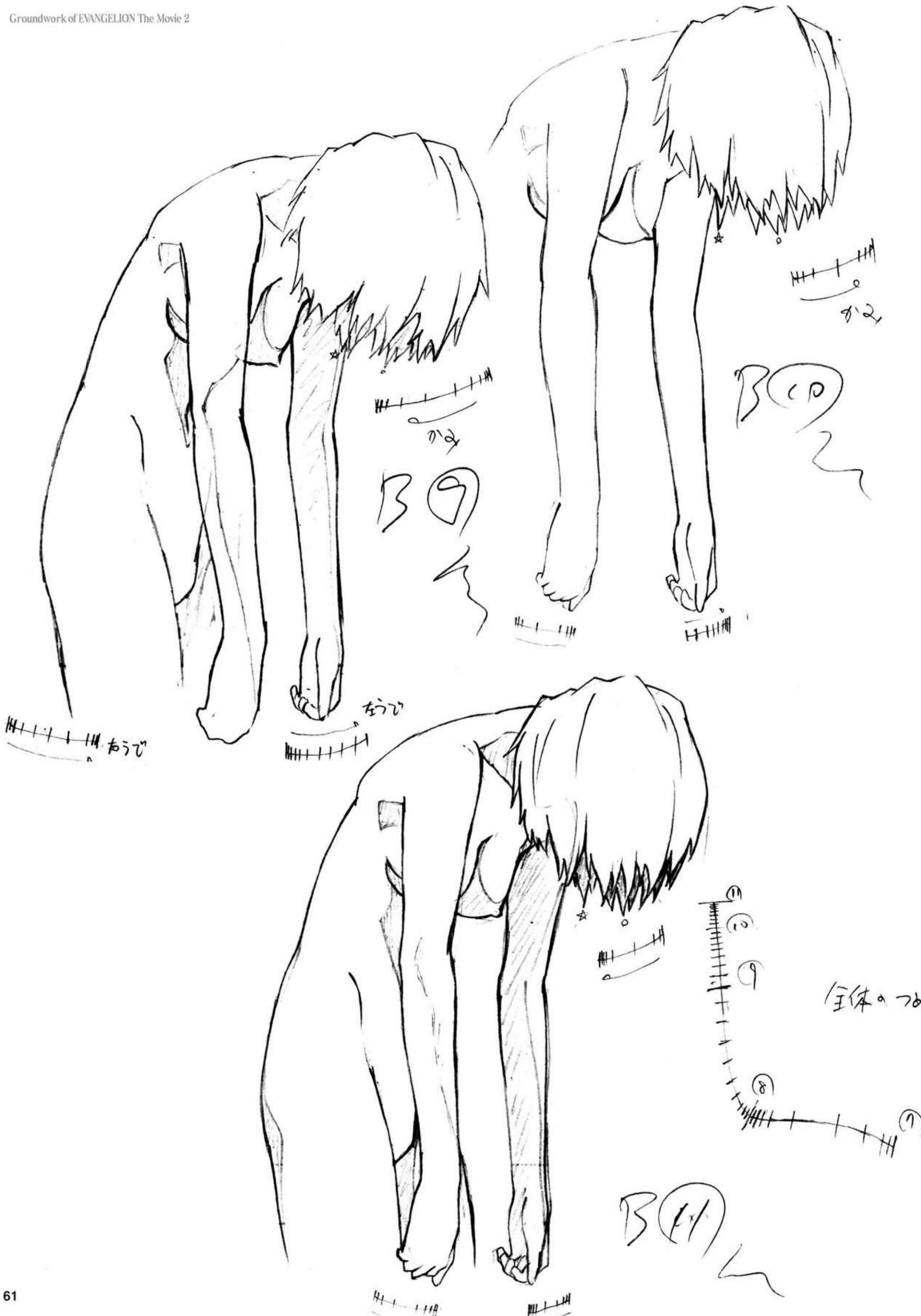

#26-C130

AD

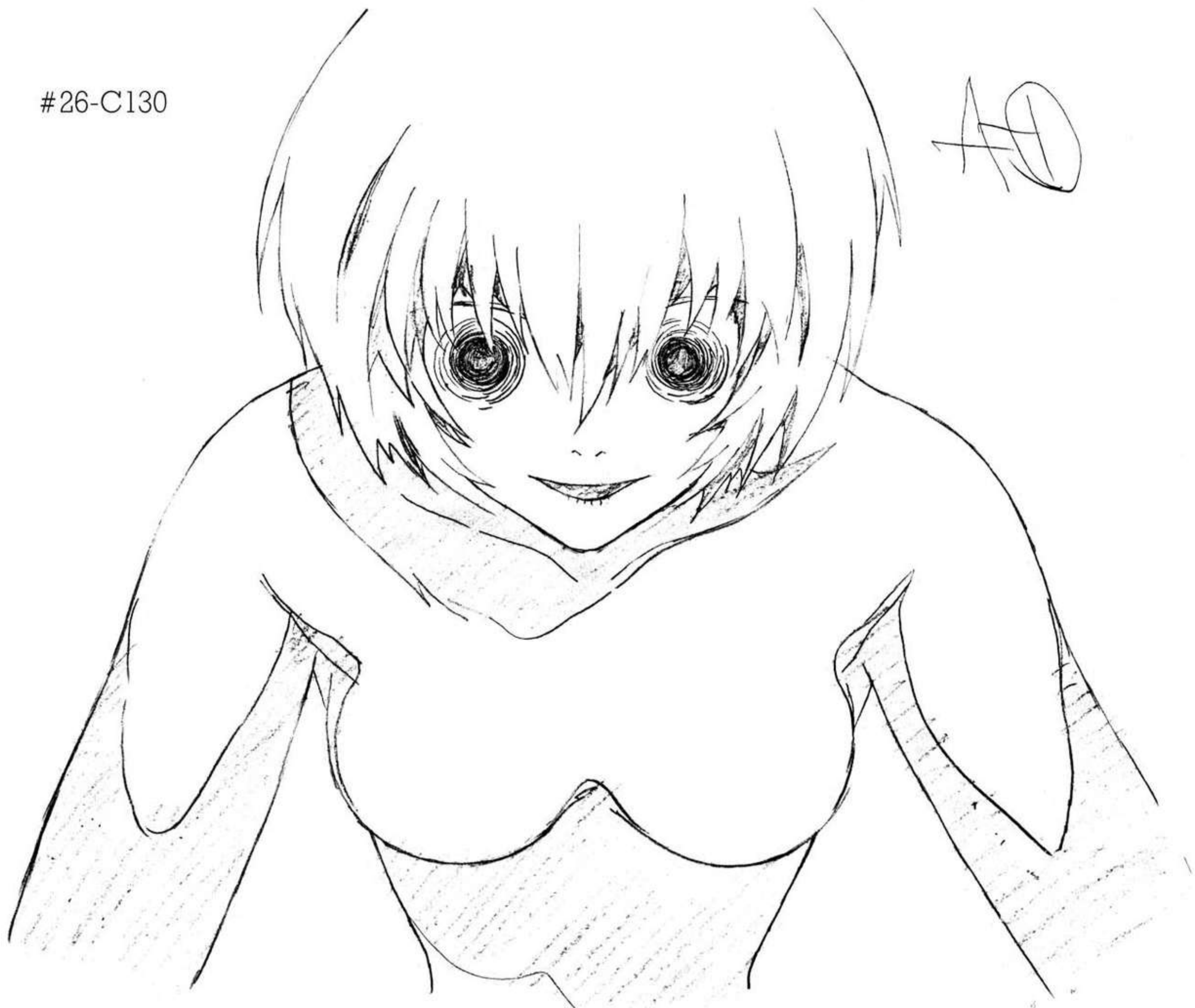

修正原画

BL
74



AD
74

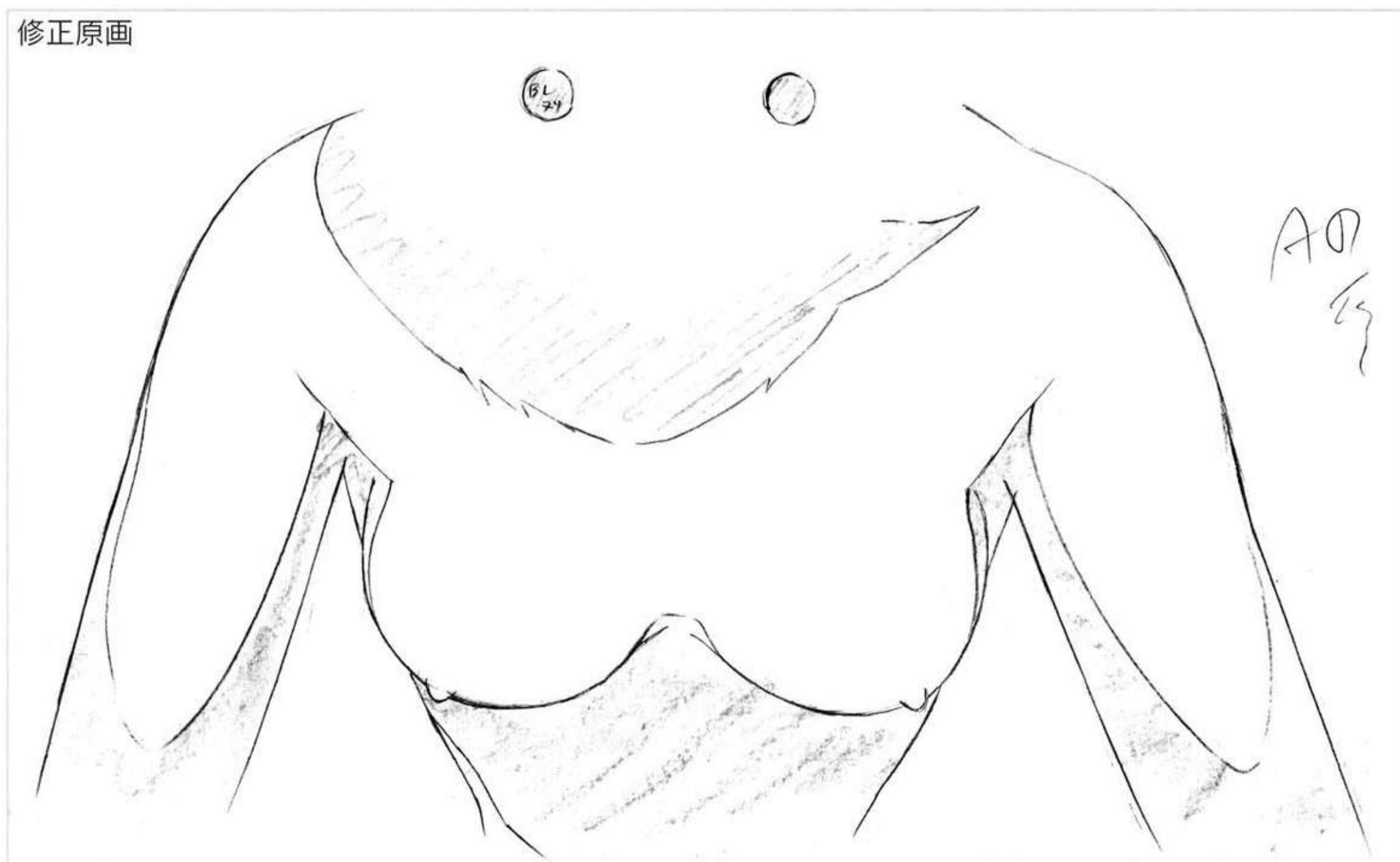

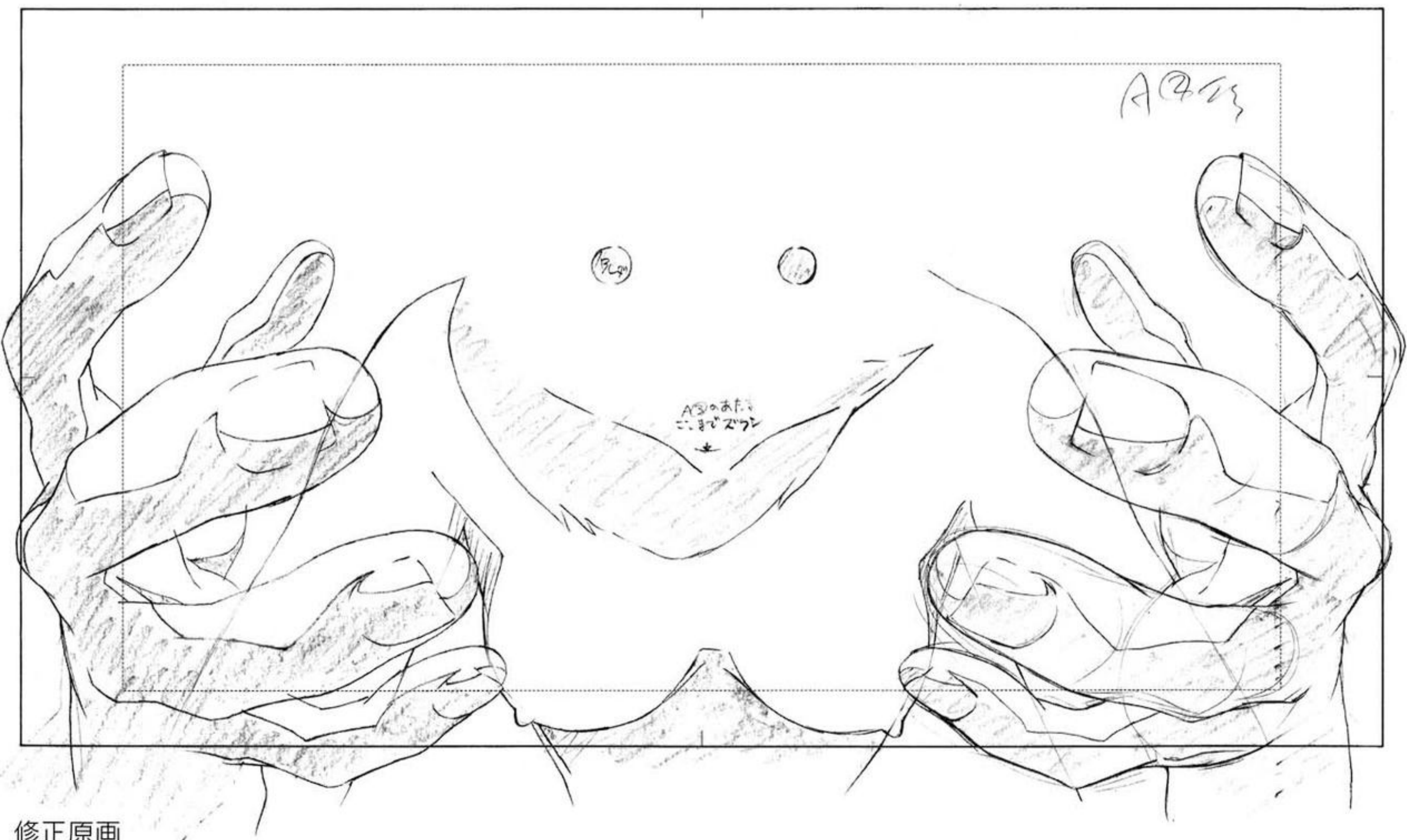

修正原画

顔 Aの
髪 Cの

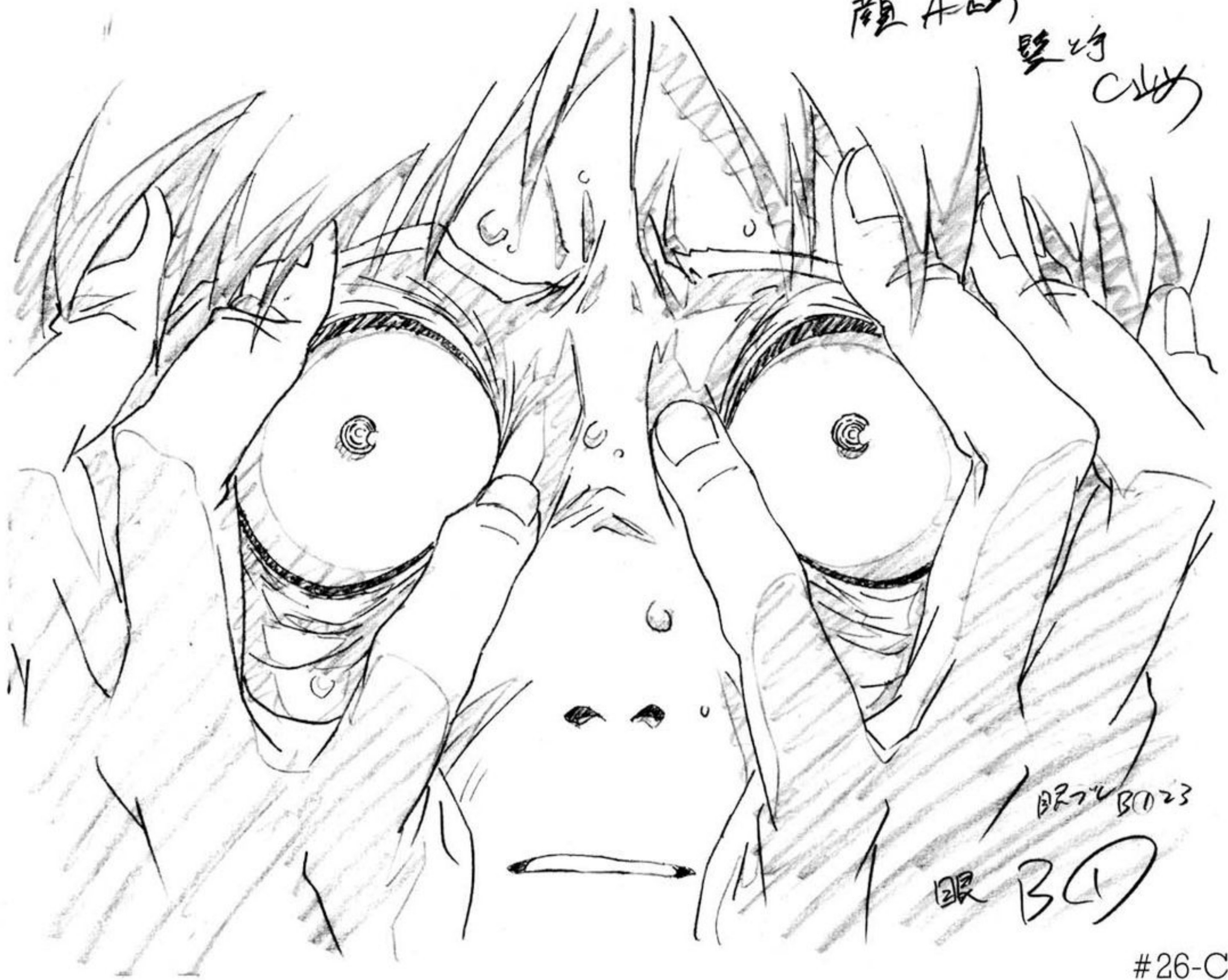

眼 Bの
BO23

#26-C129

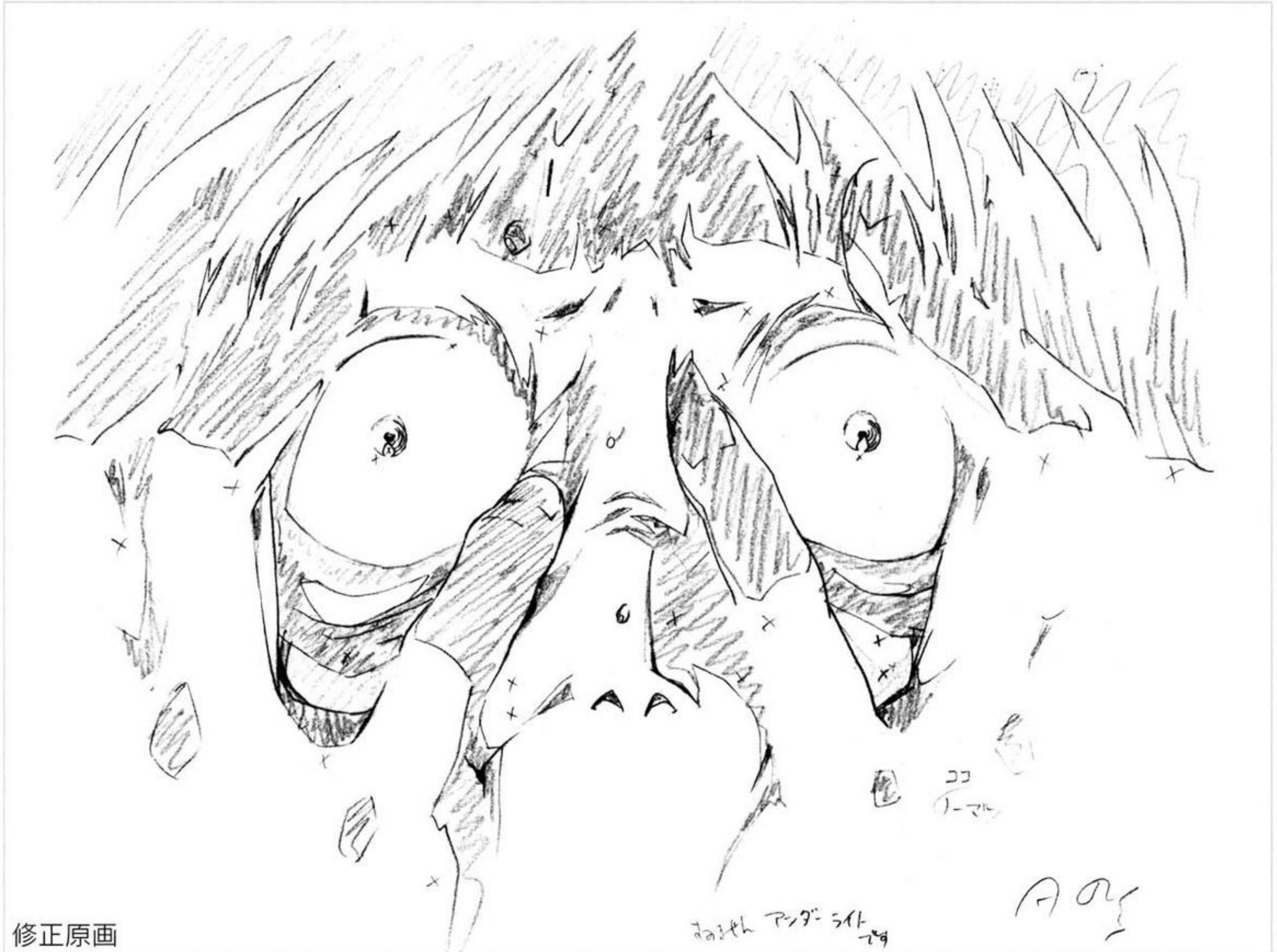

修正原画

おはつ 2024

Aの

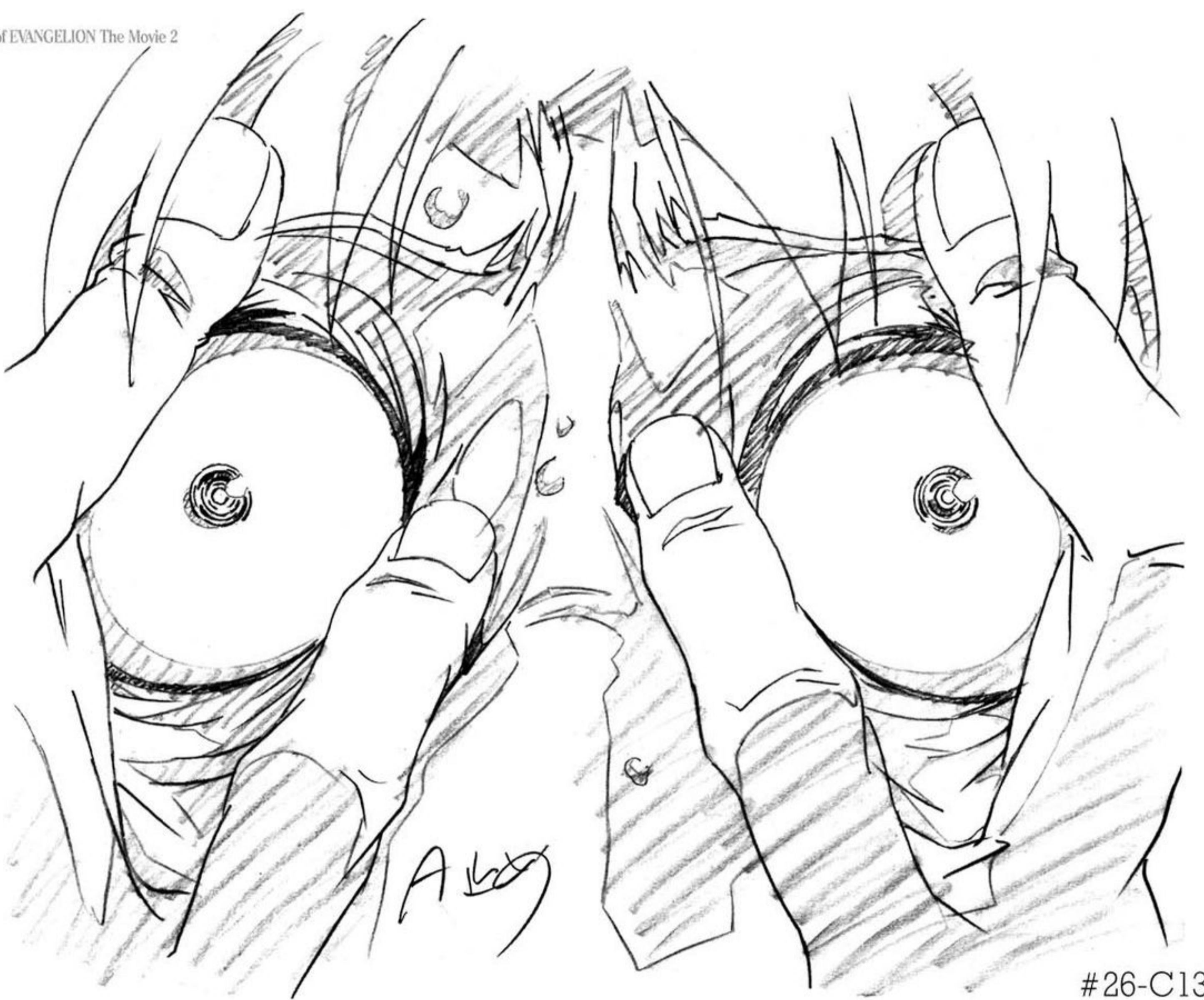

#26-C131

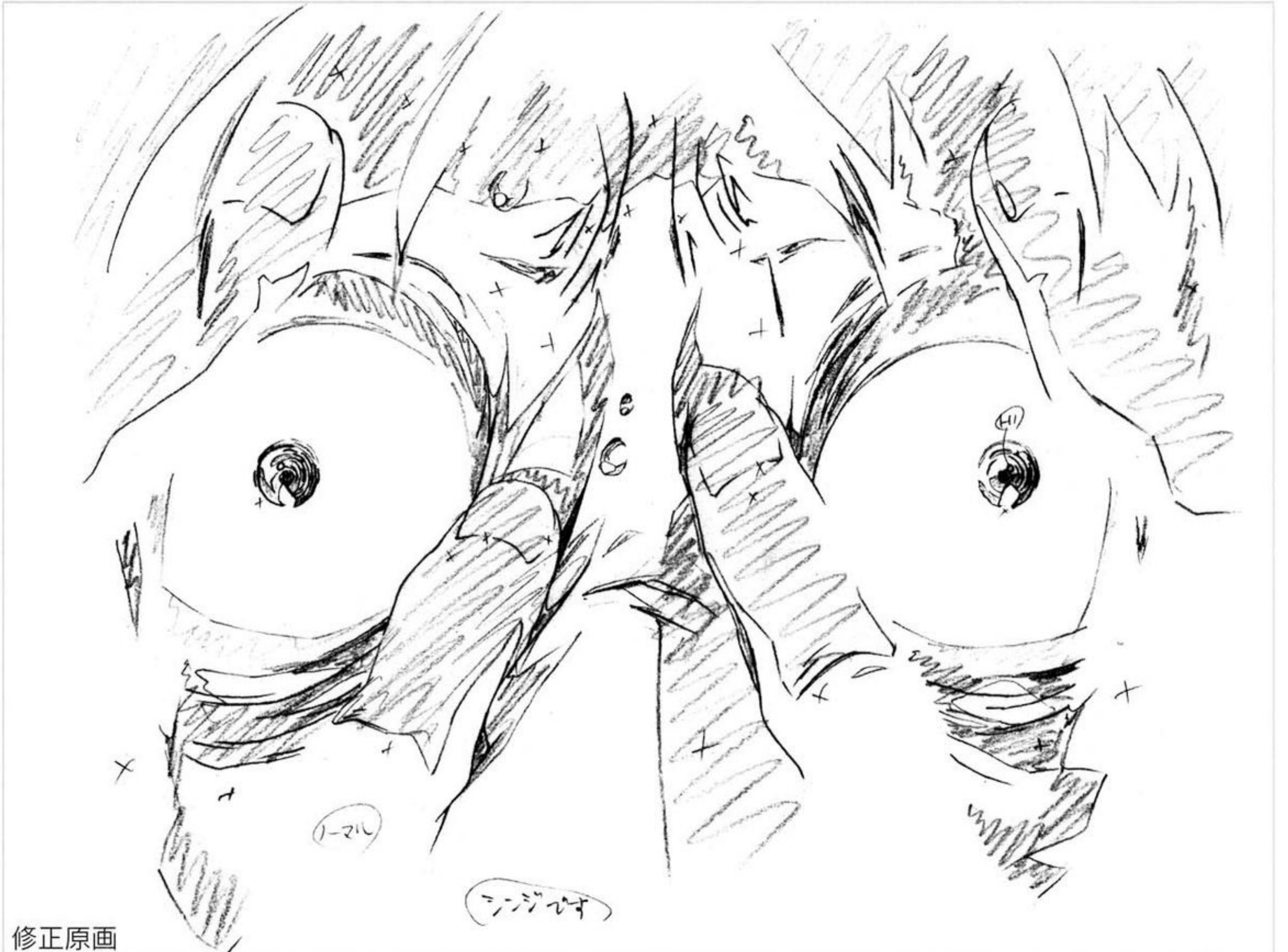

修正原画

#26-C128B

A ③
ㄣ



A ①
ㄣ



A ②
ㄣ



③は
ちちおーず
です。



#26-C134レイアウト

Book ③ 引き 1/0.5 = 1

Book 引き、1/0 かしら位置

Book ③ 1/0.325 = 1

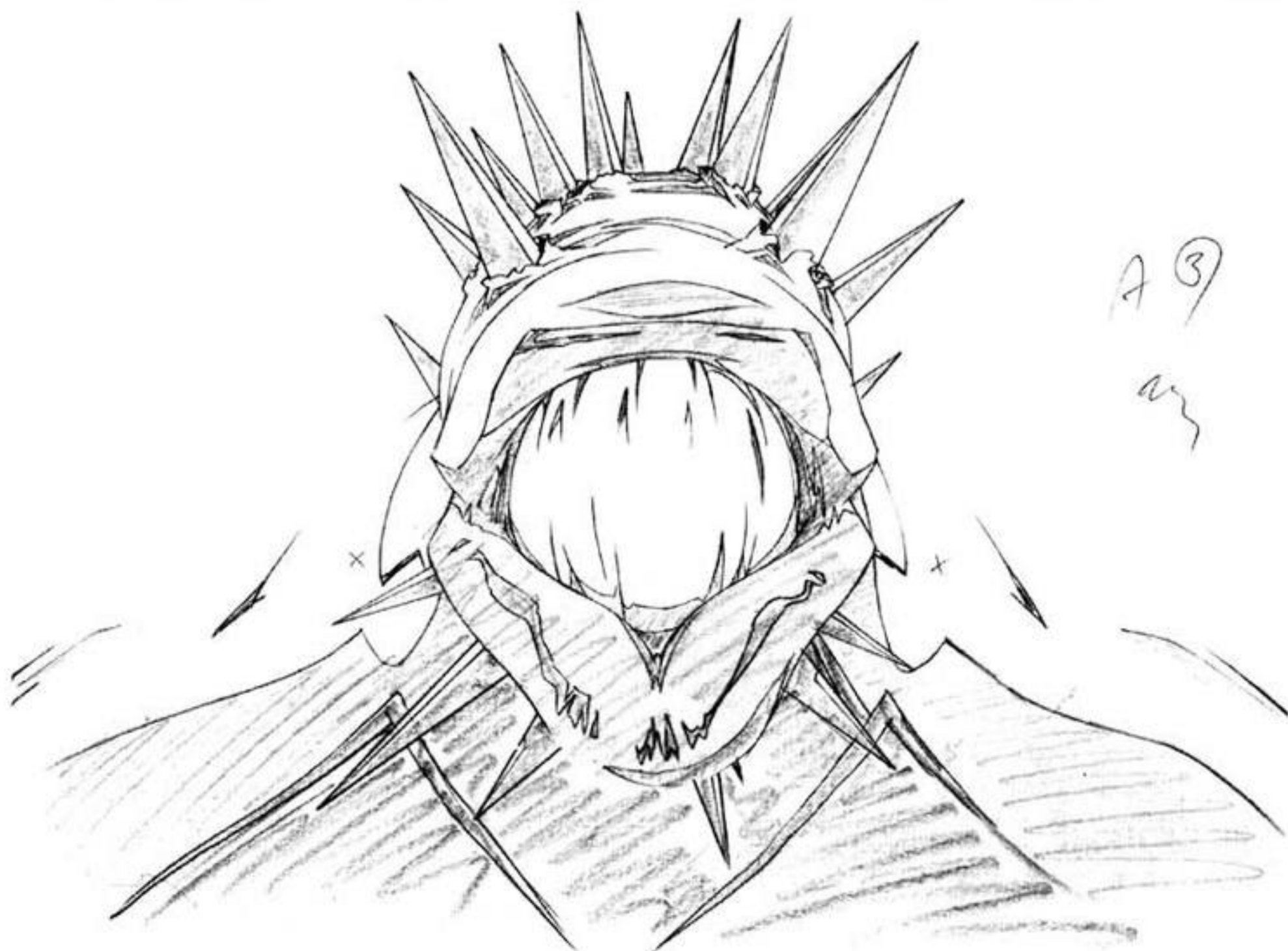
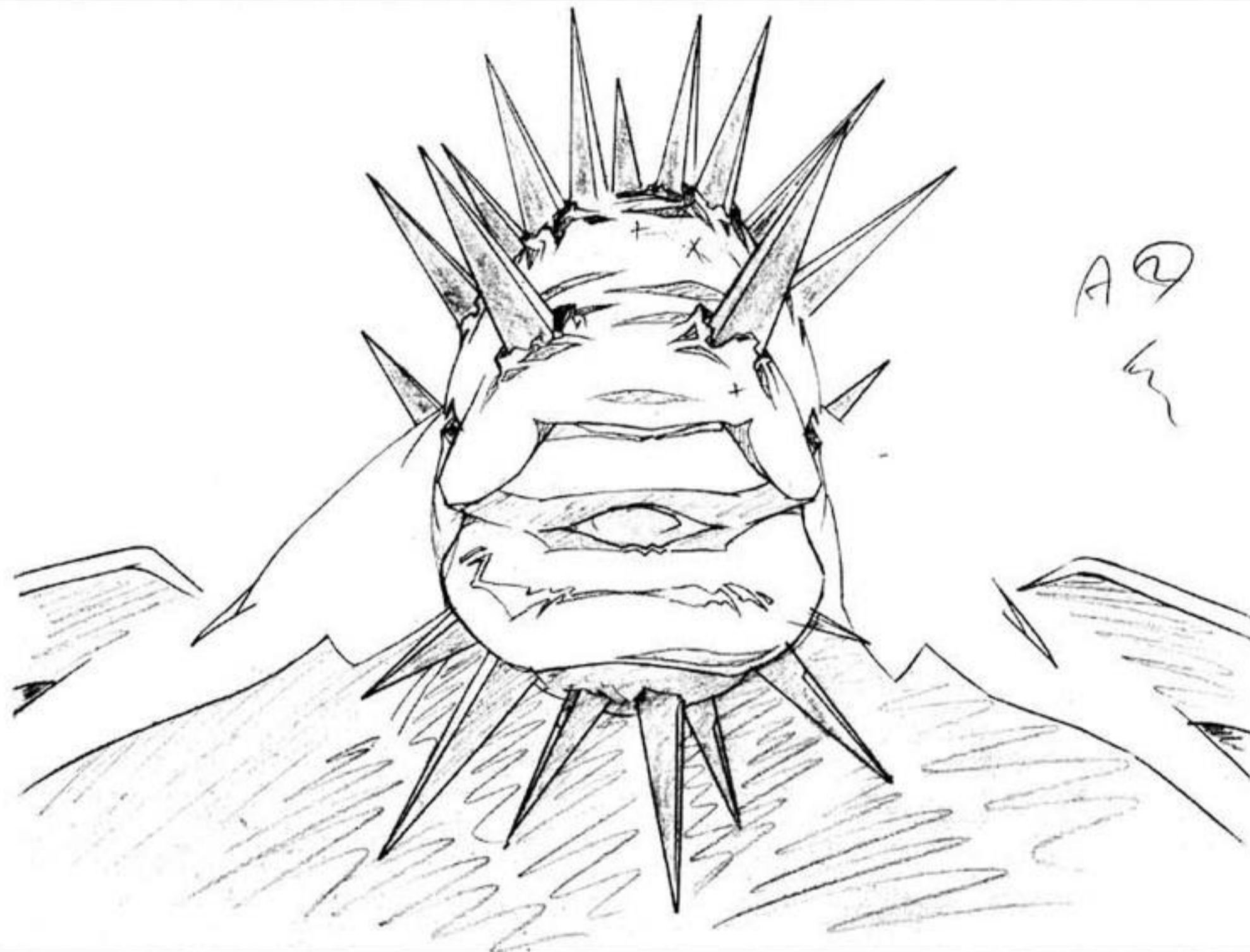

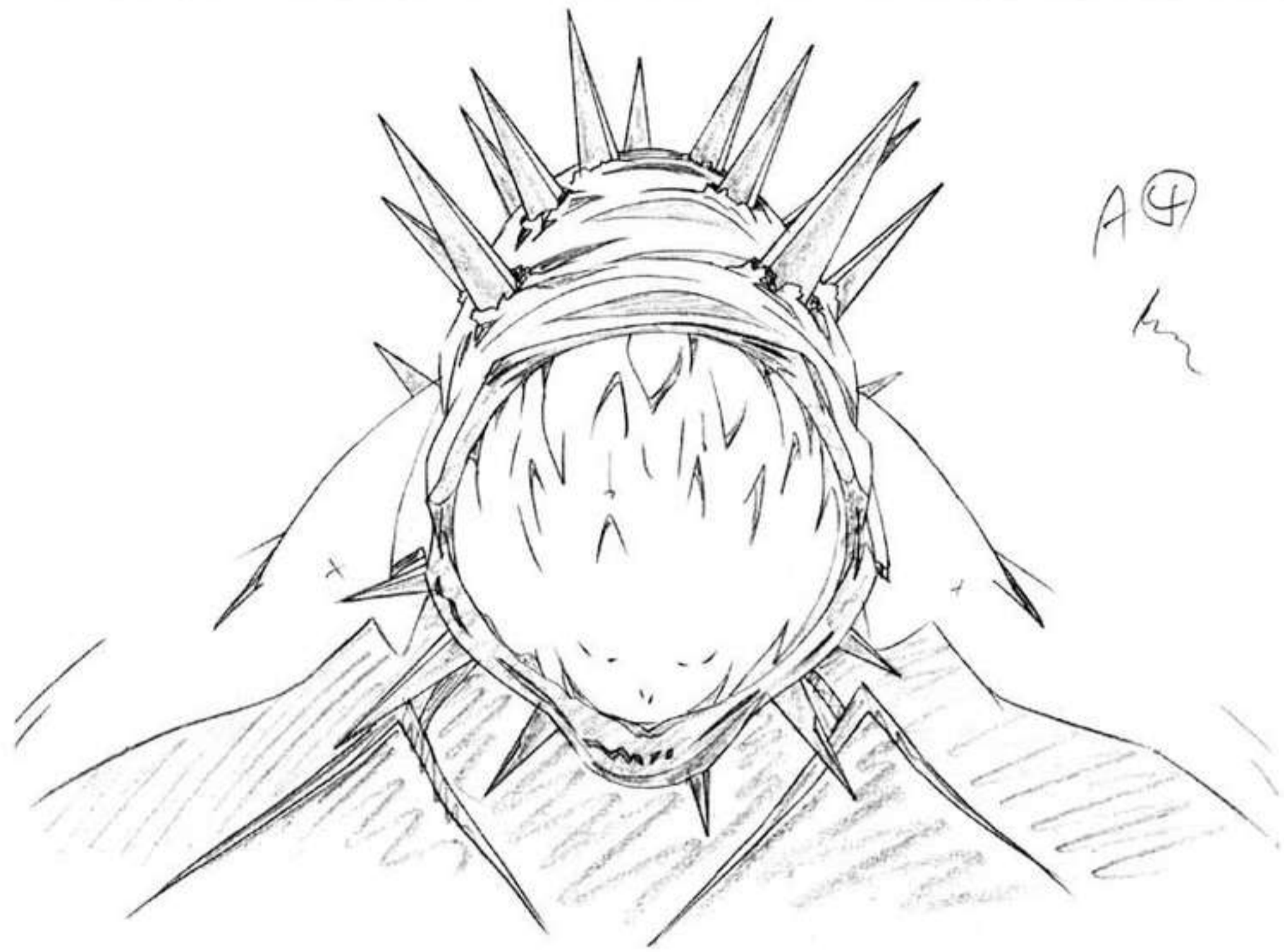



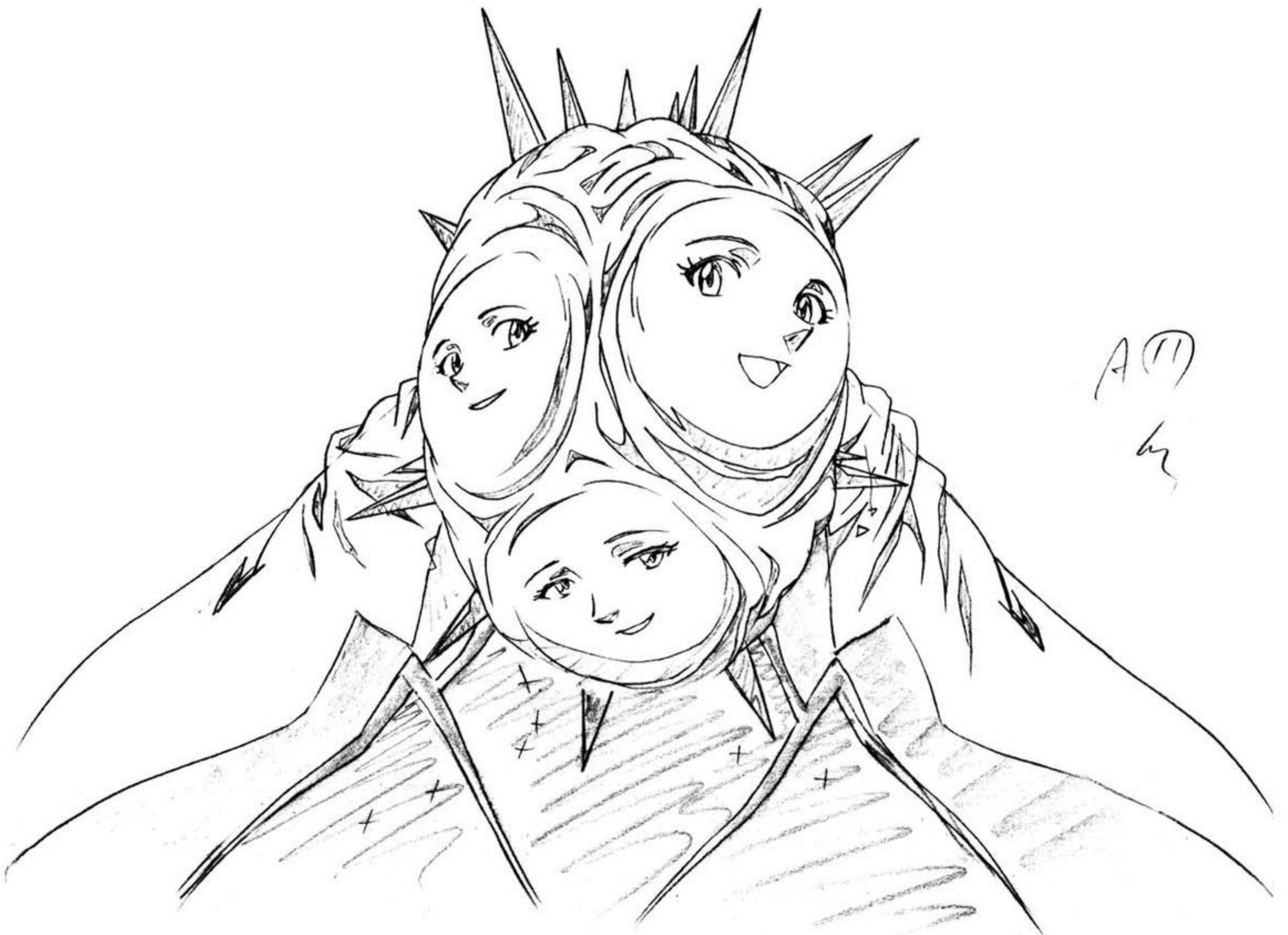
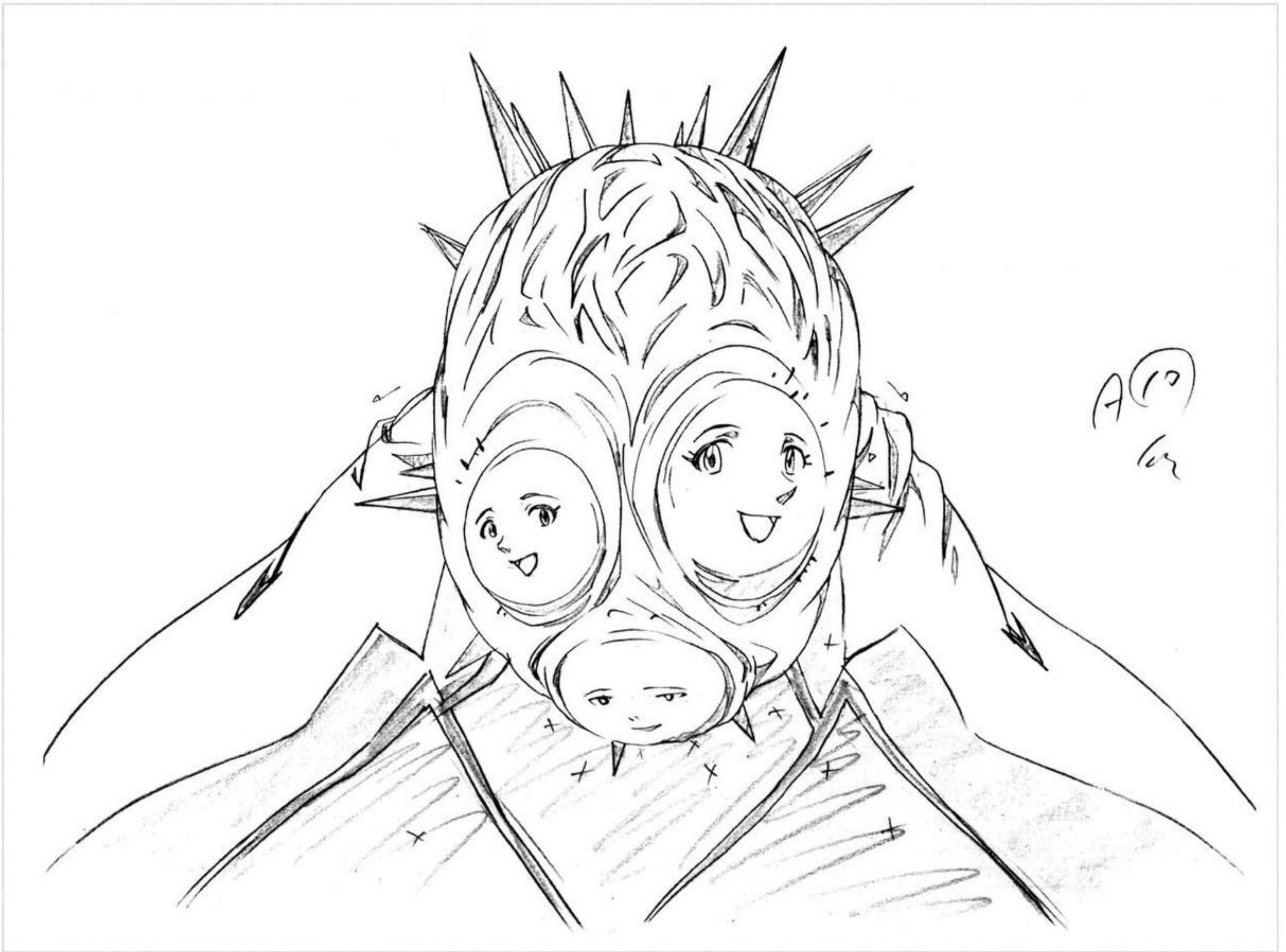

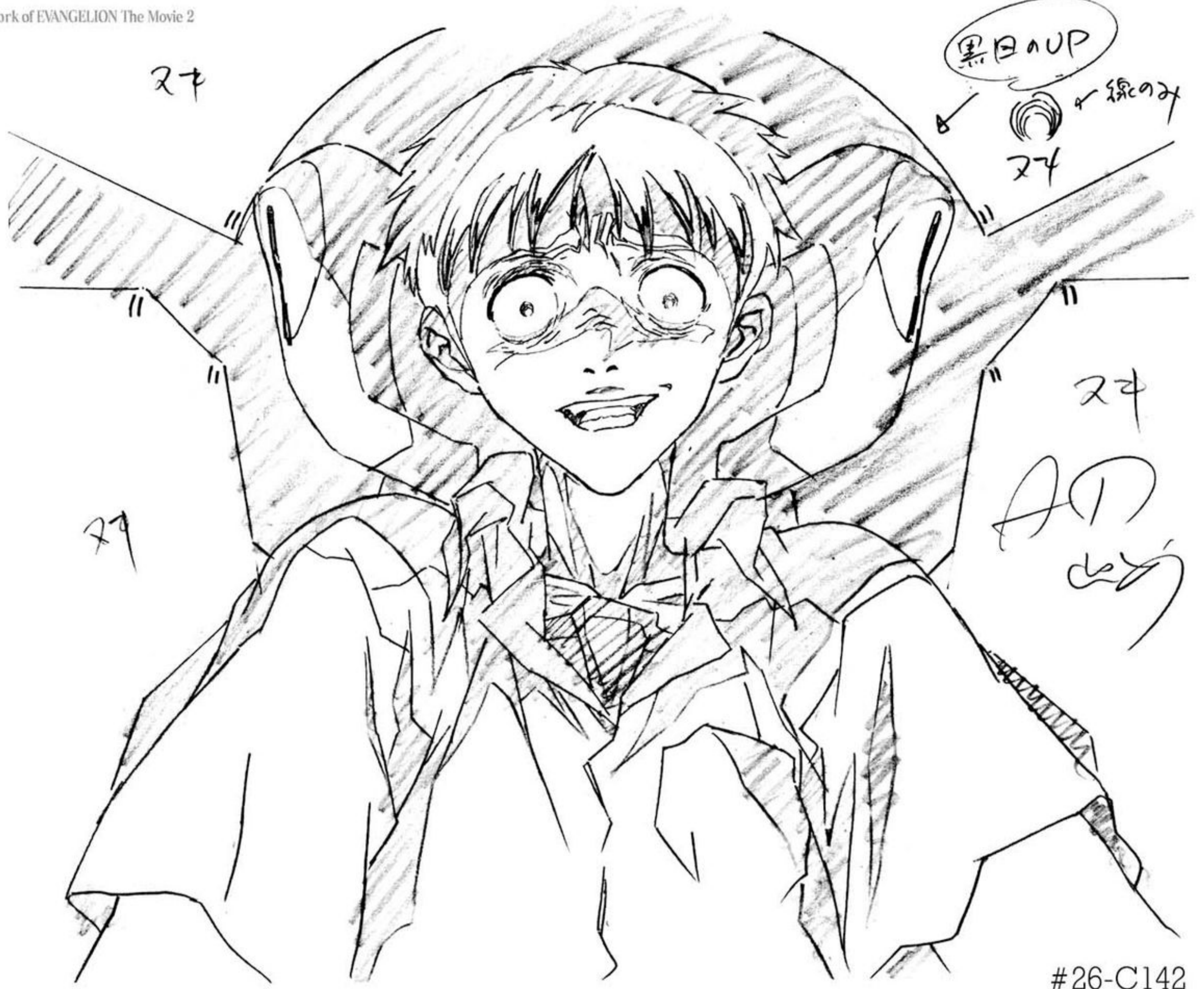

#26-C142

修正原画



A③

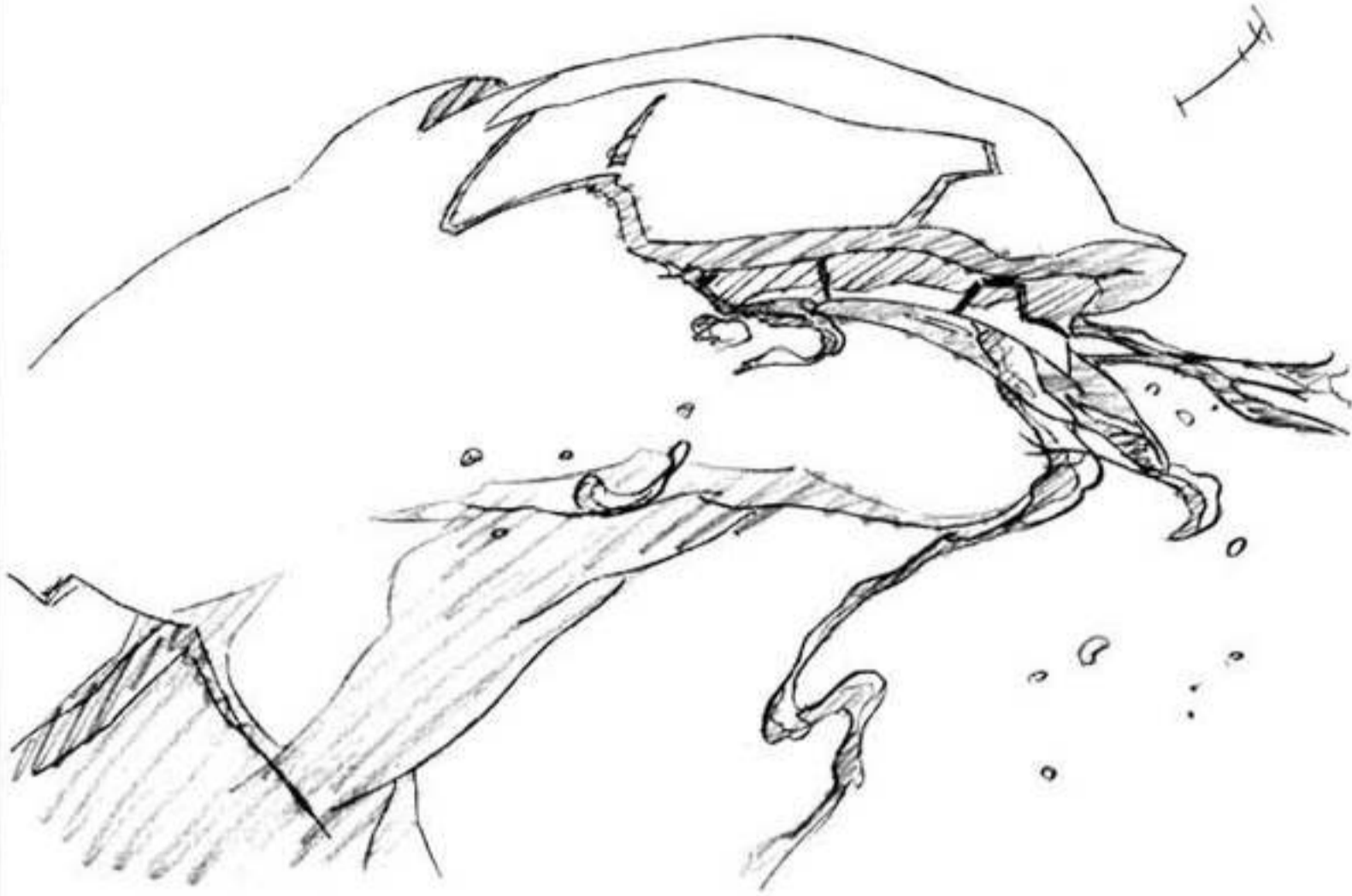

A①

修正原画

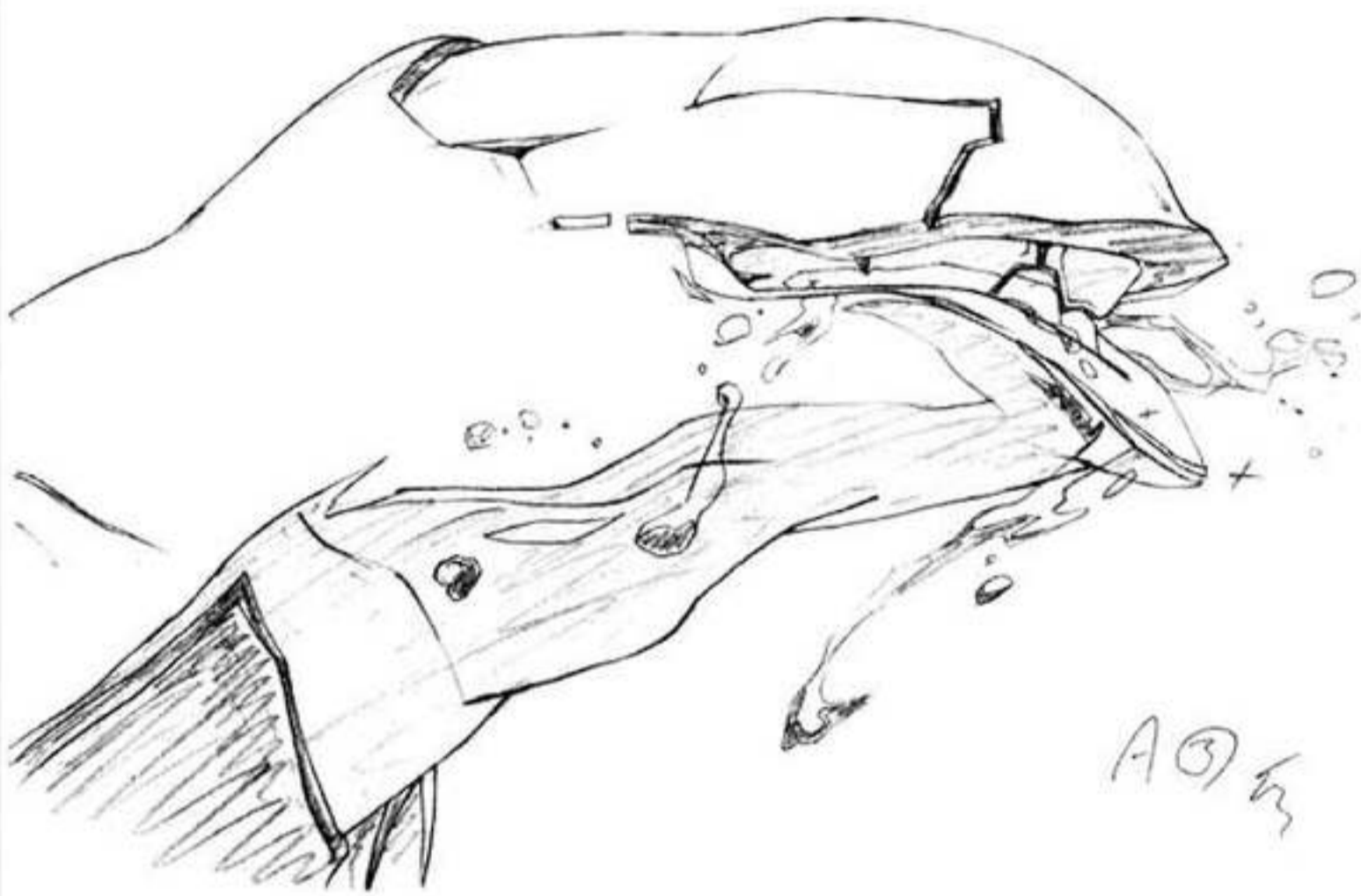

A②

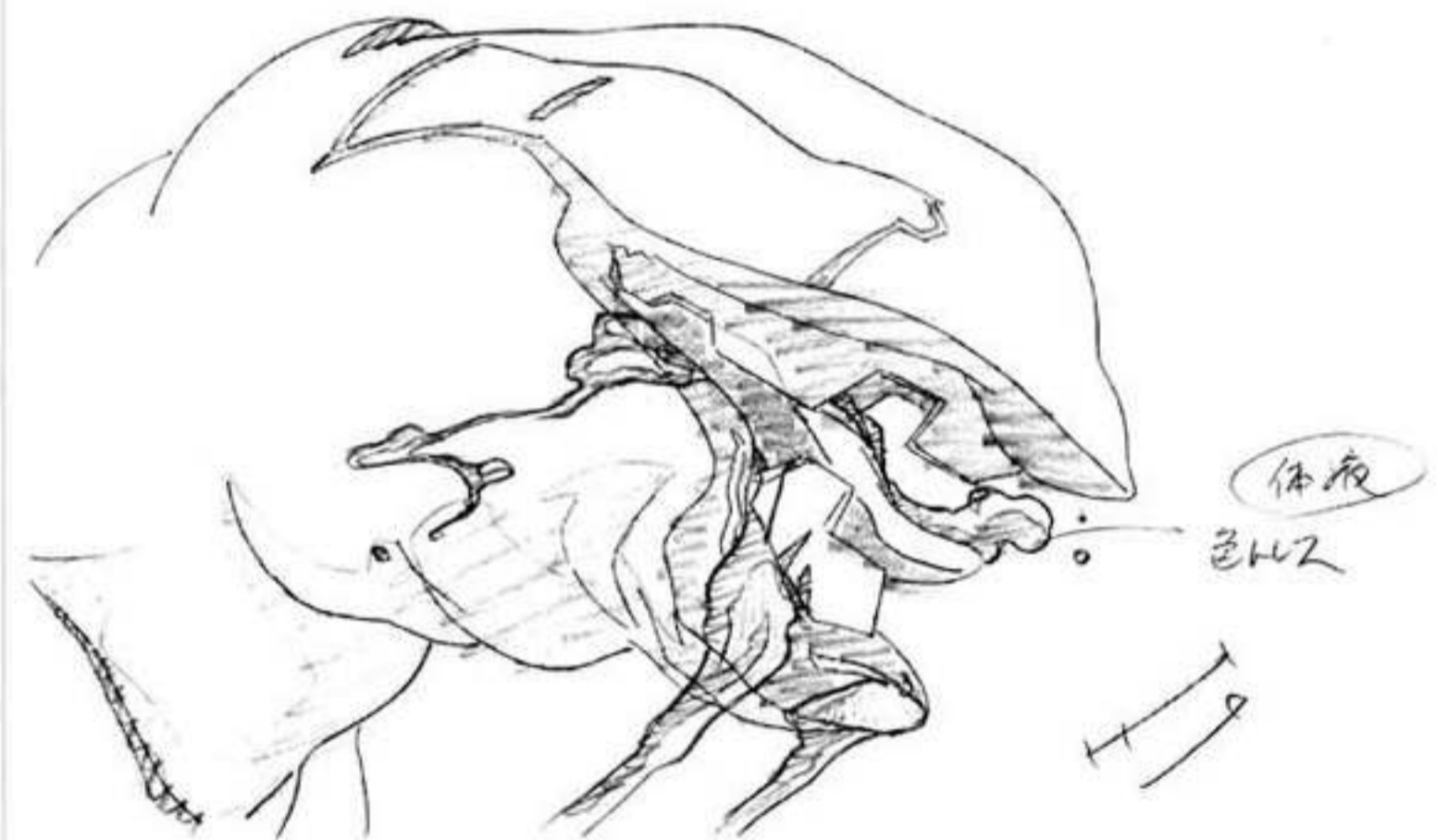

修正原画

A④

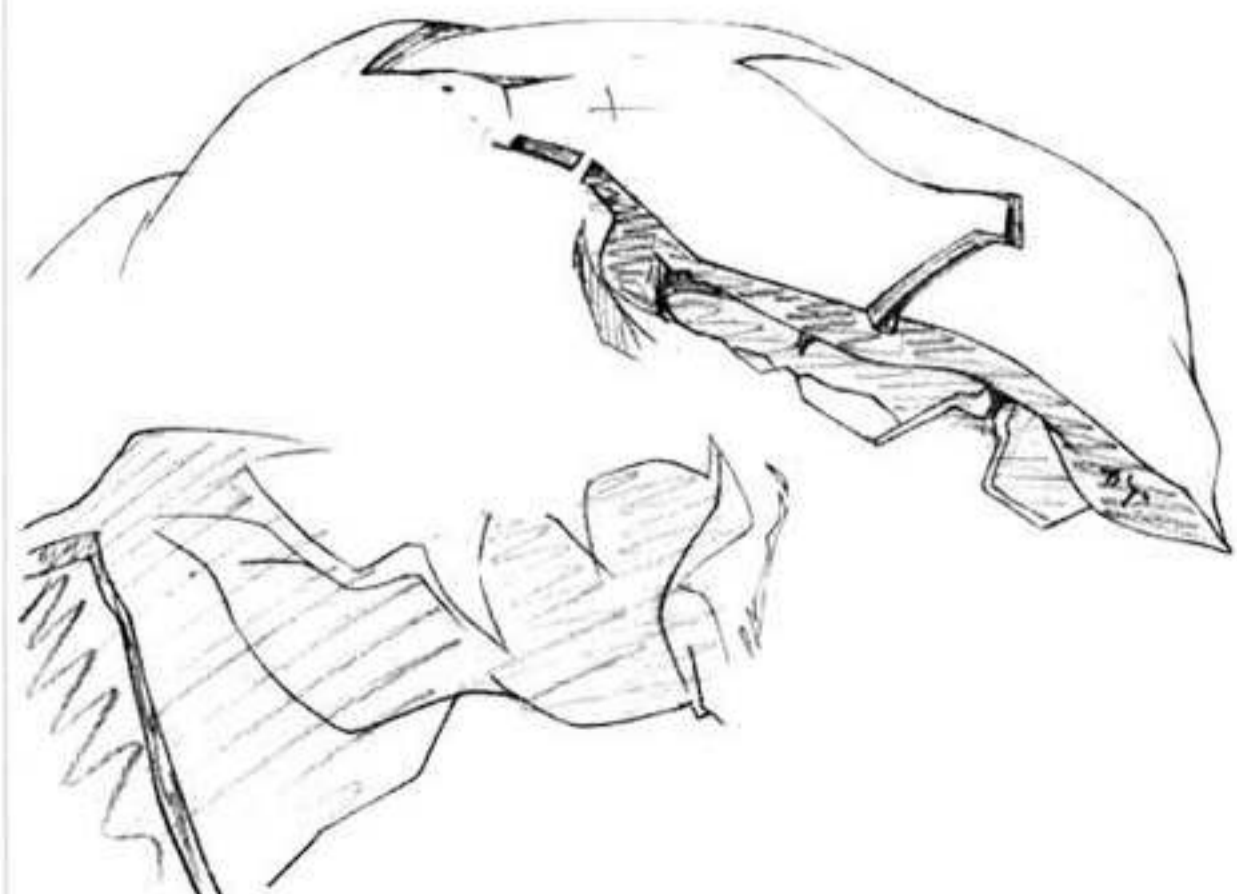
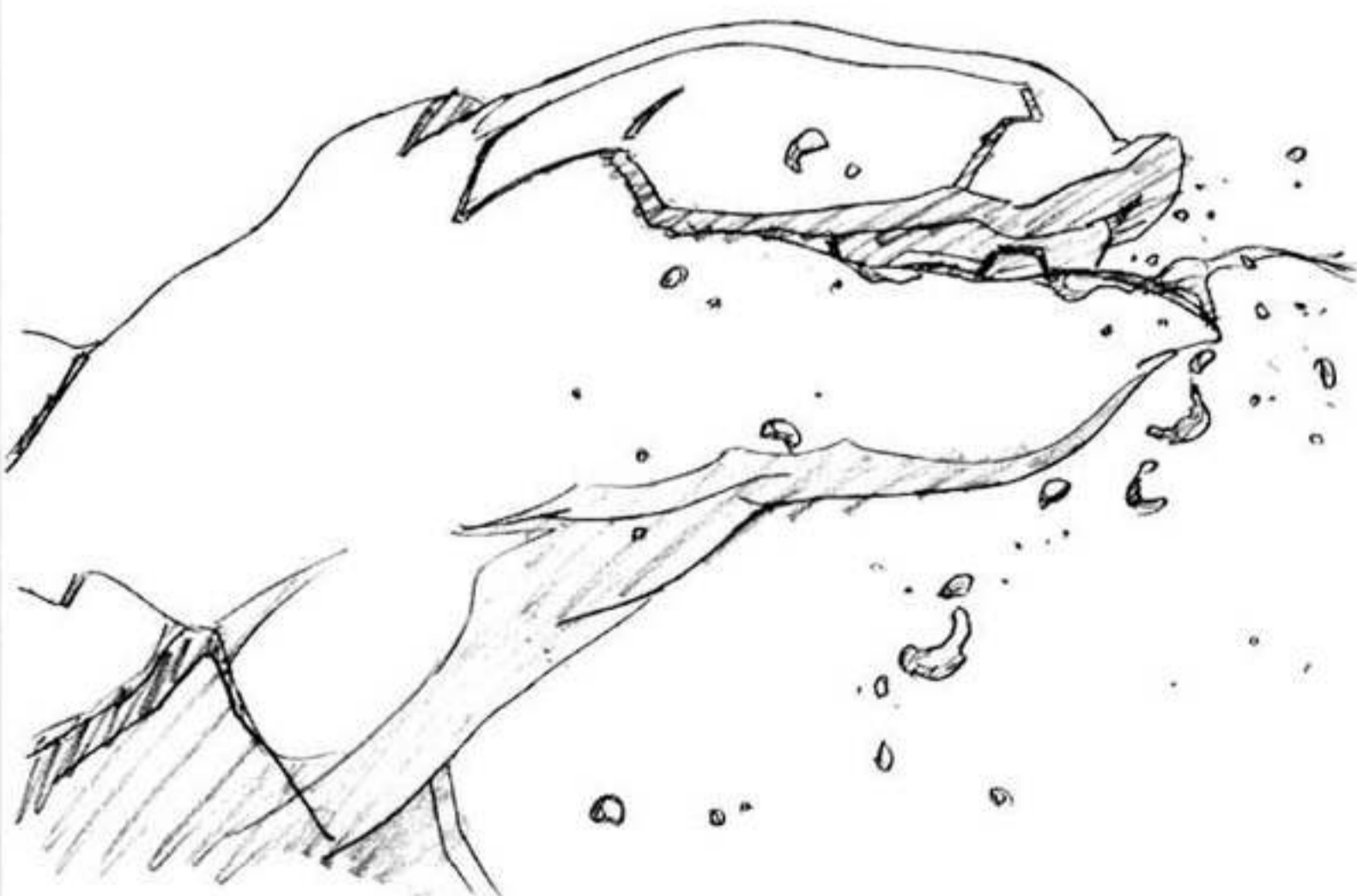

修正原画

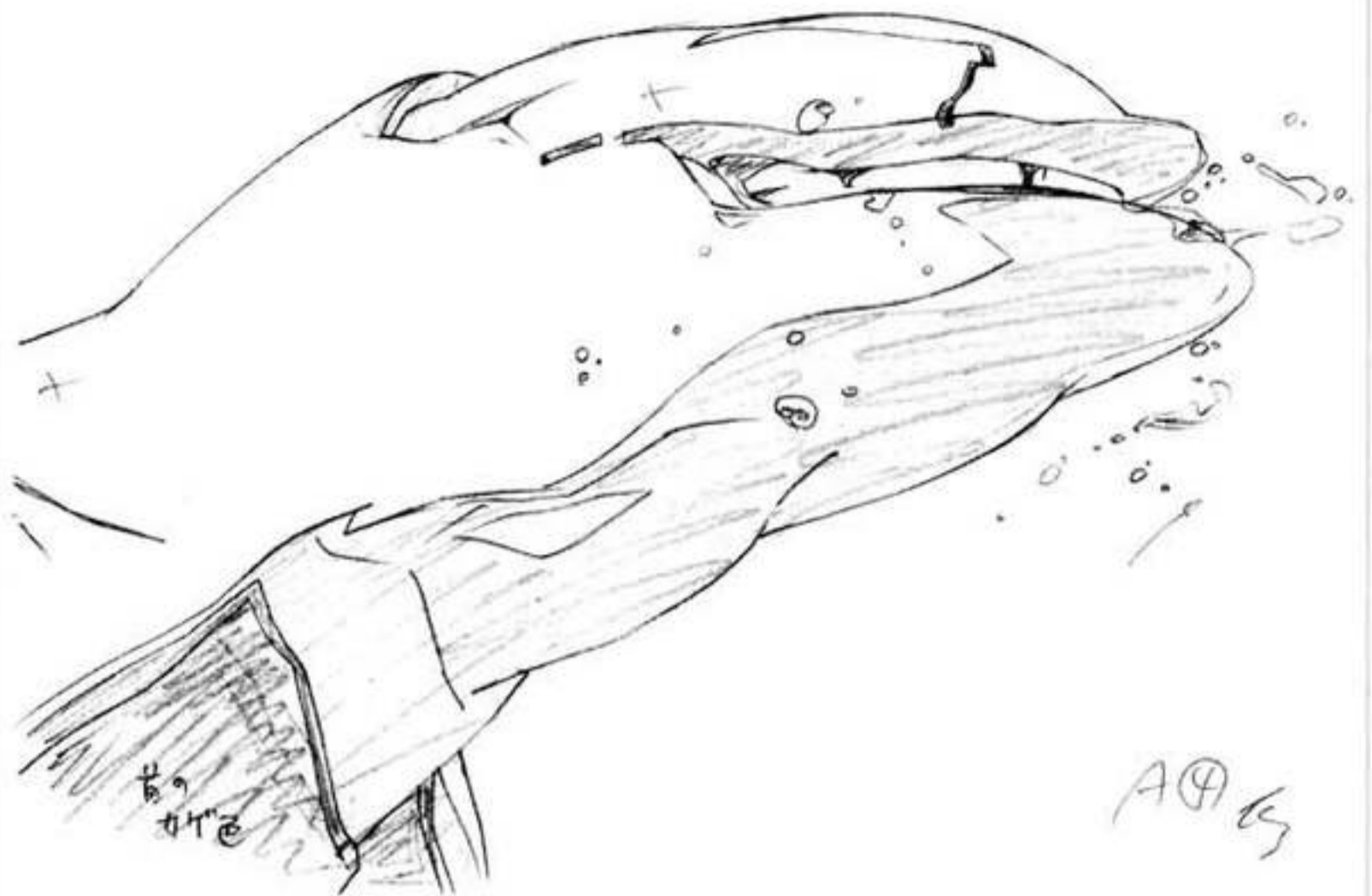
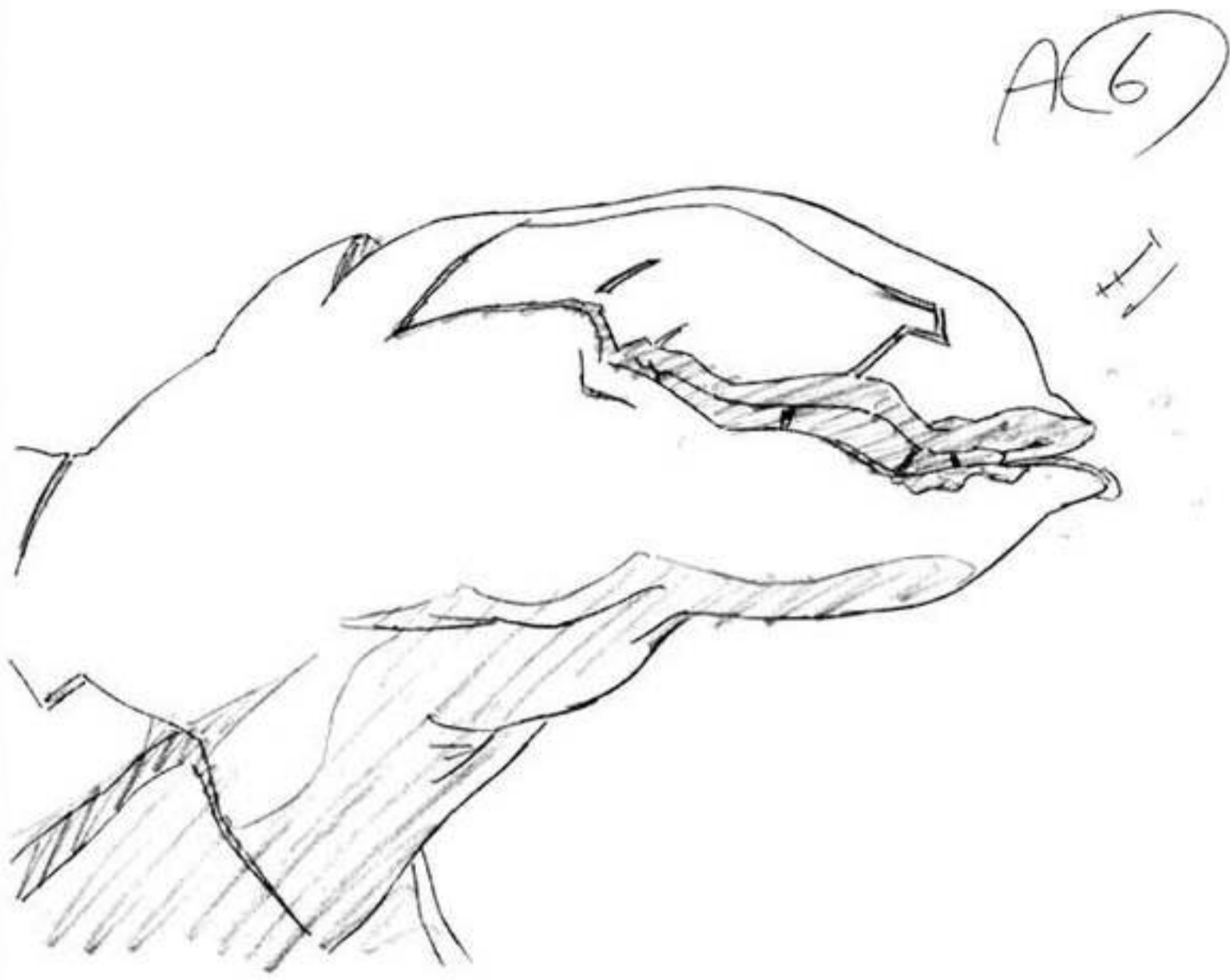

修正原画

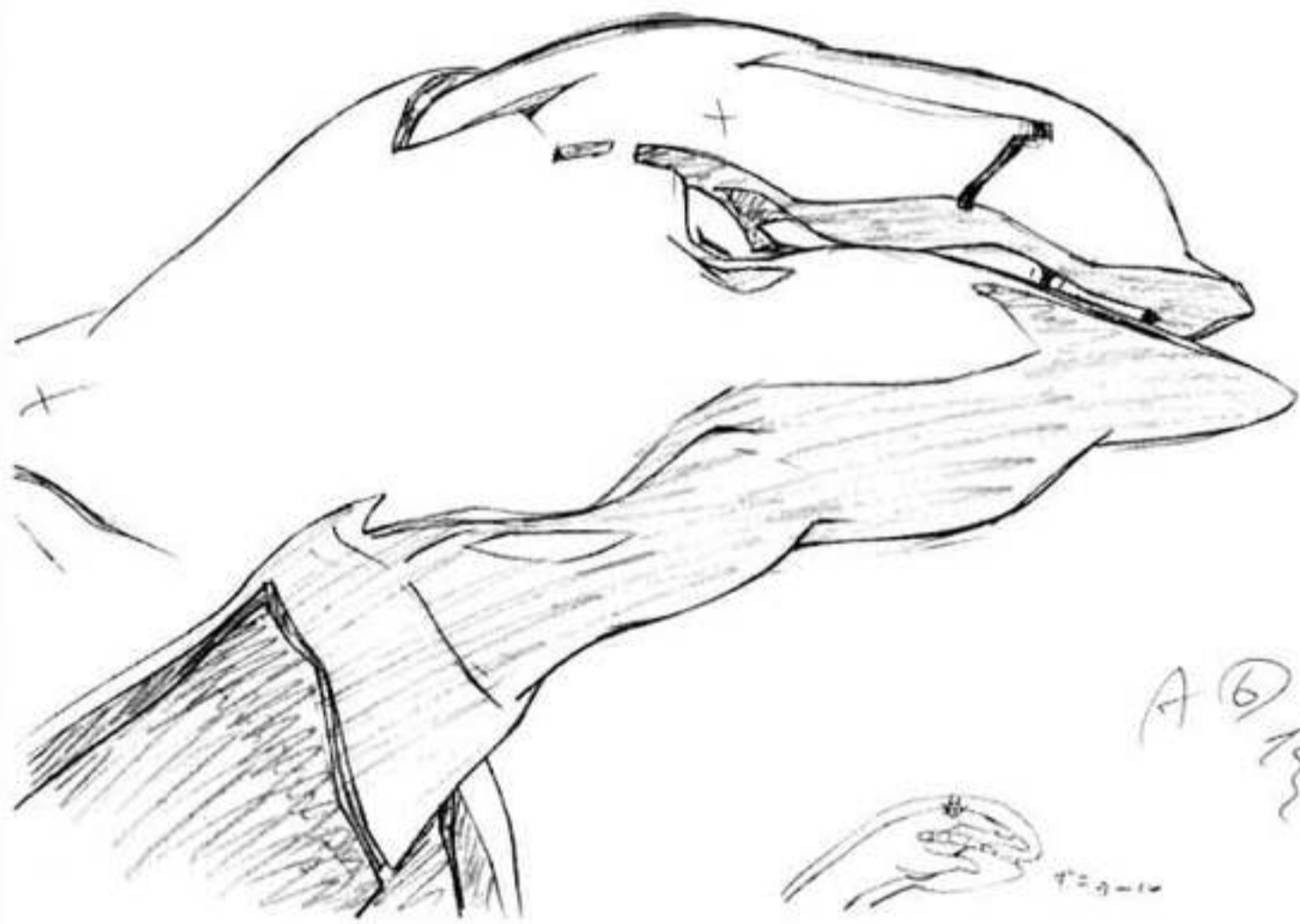

修正原画

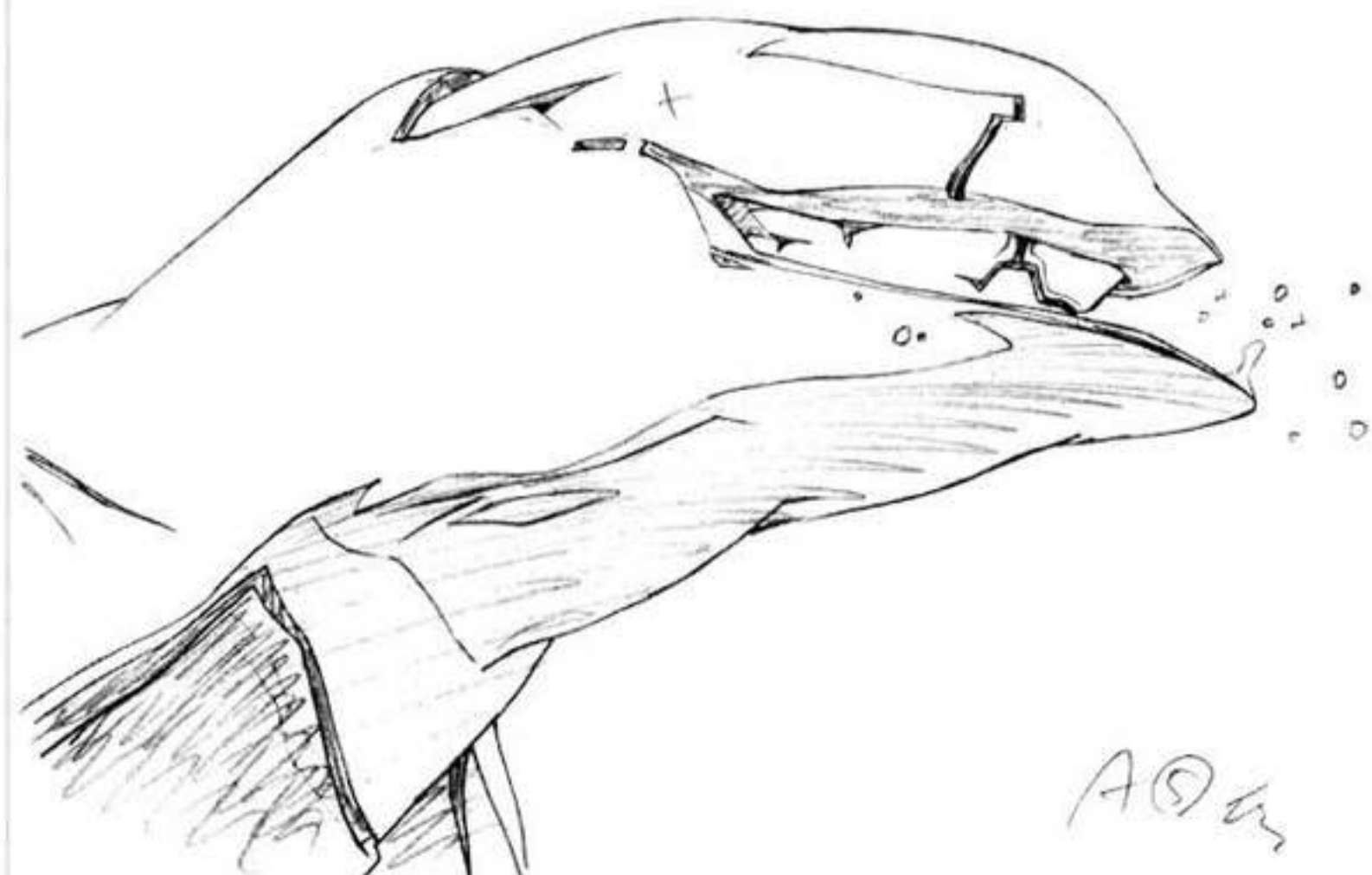
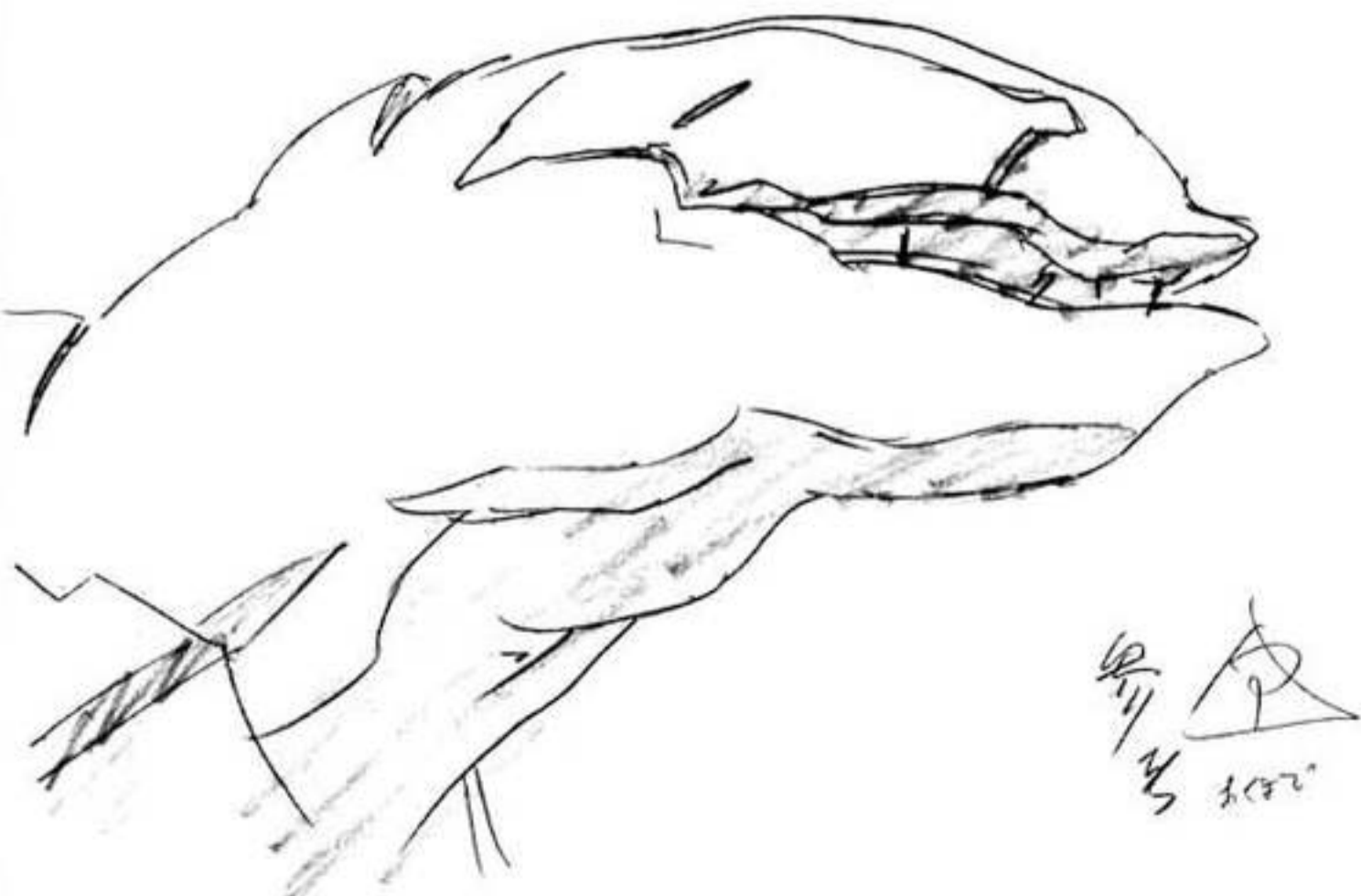

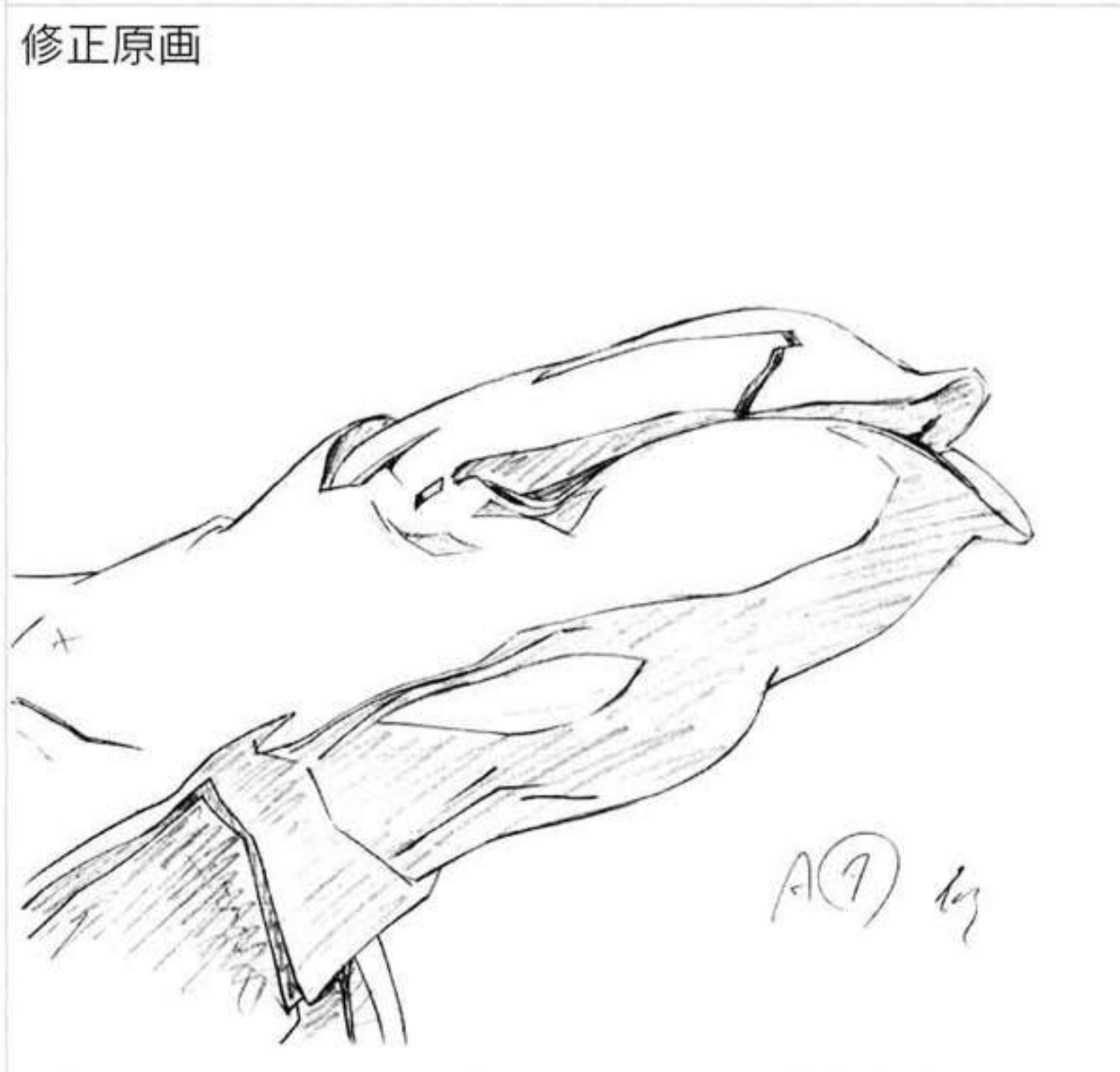
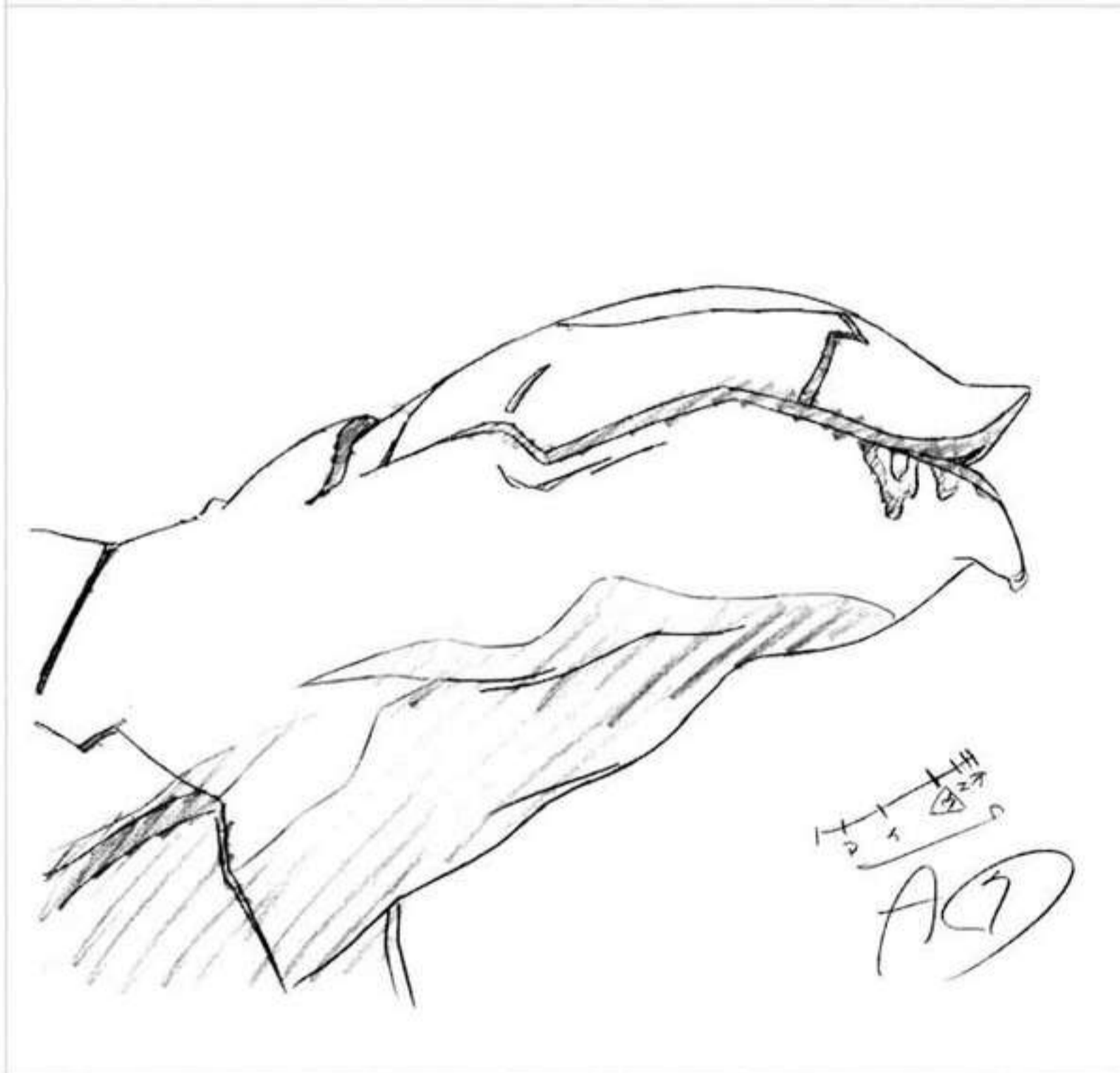
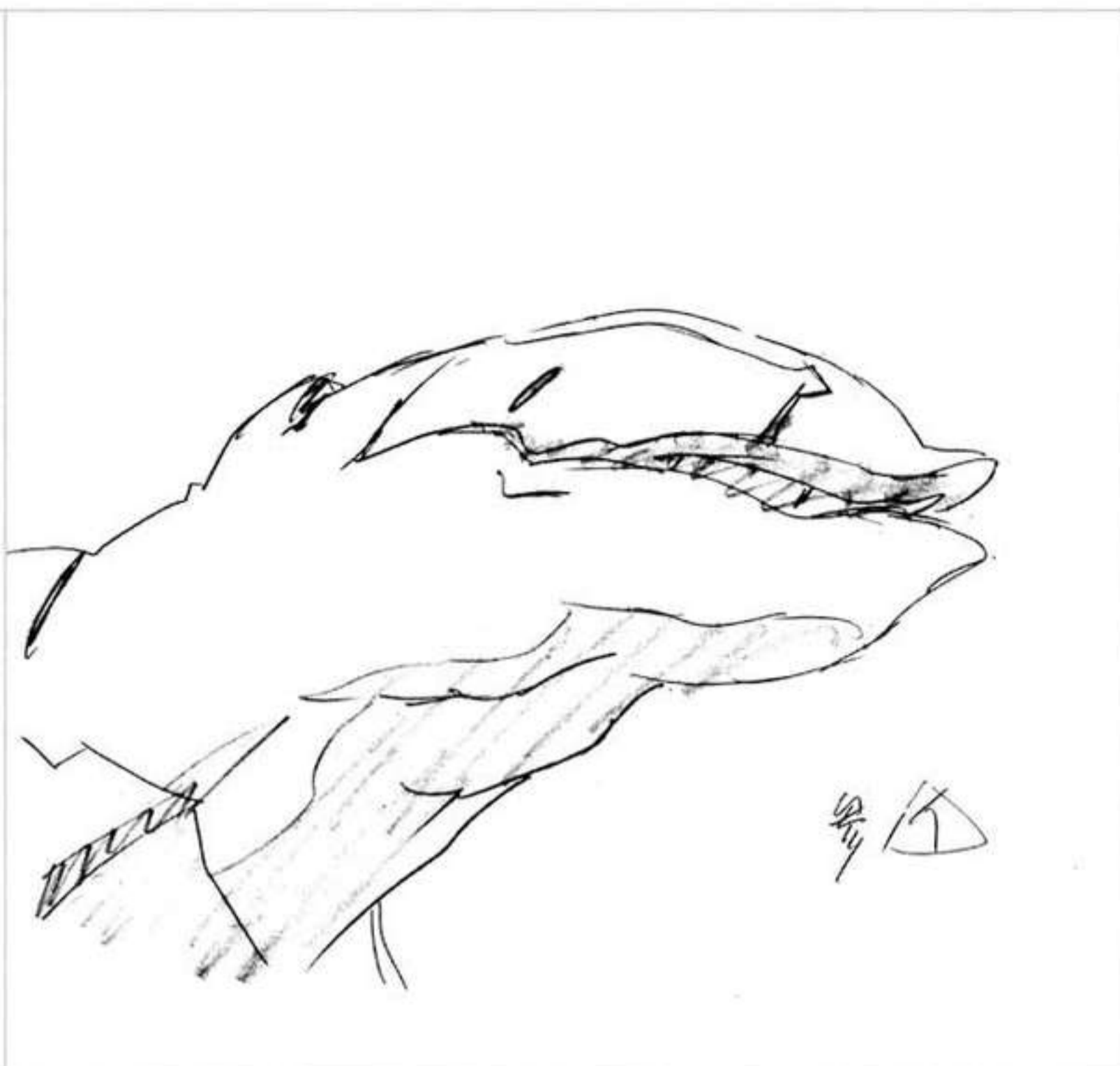

修正原画

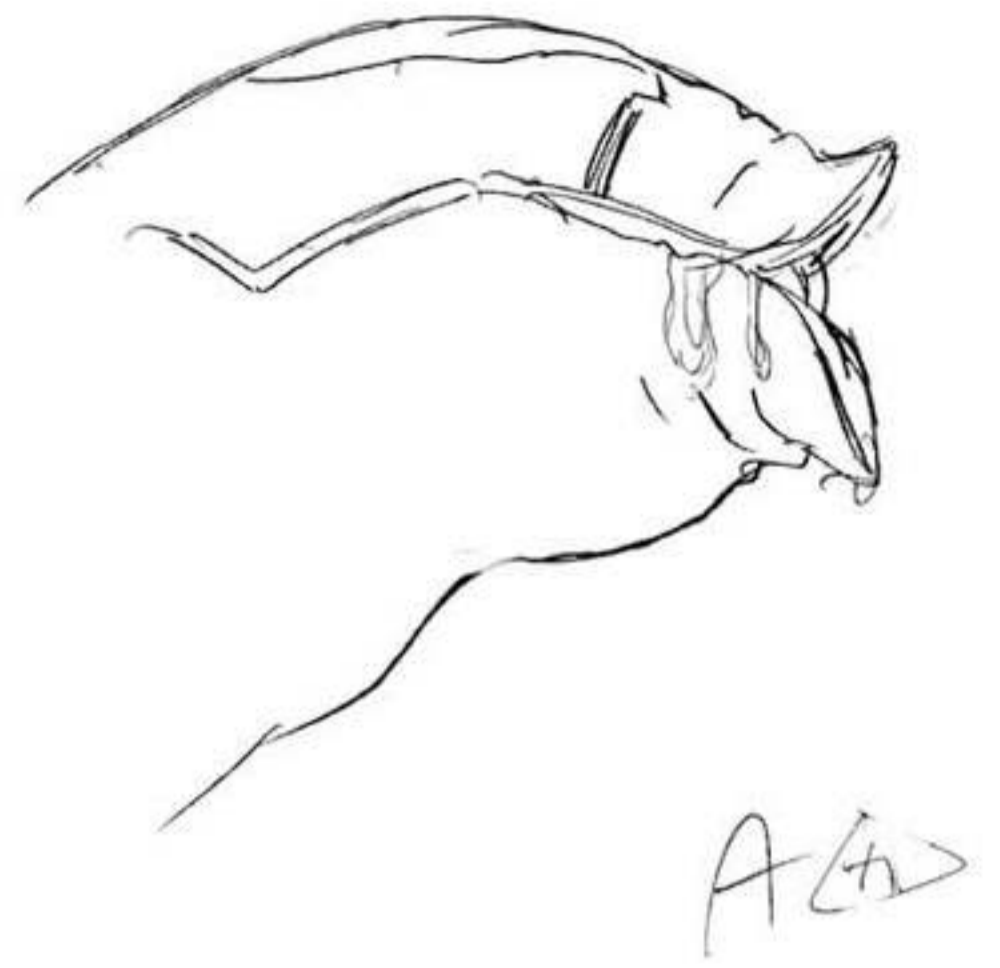

修正原画

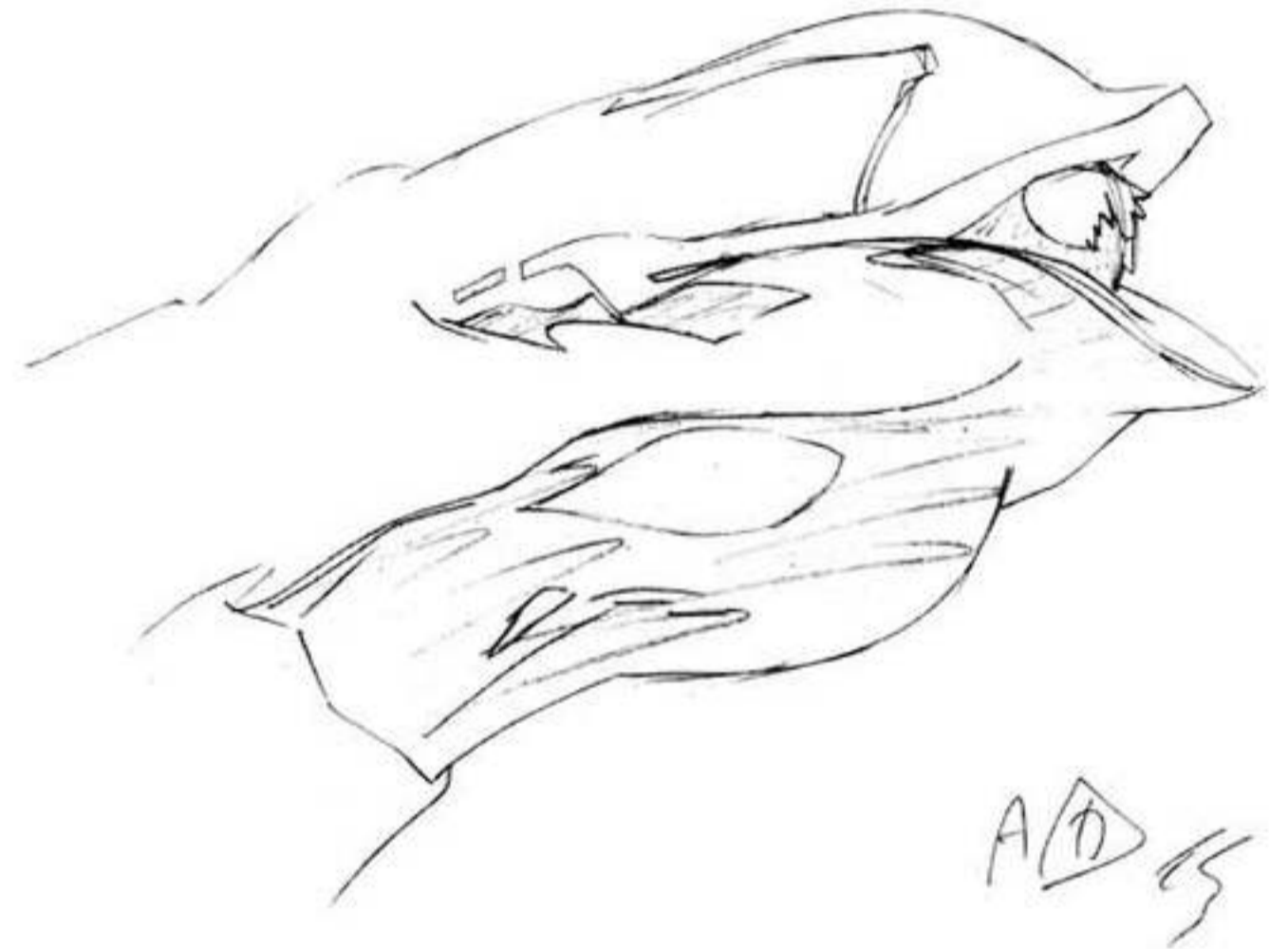

修正原画



修正原画



(17) 15

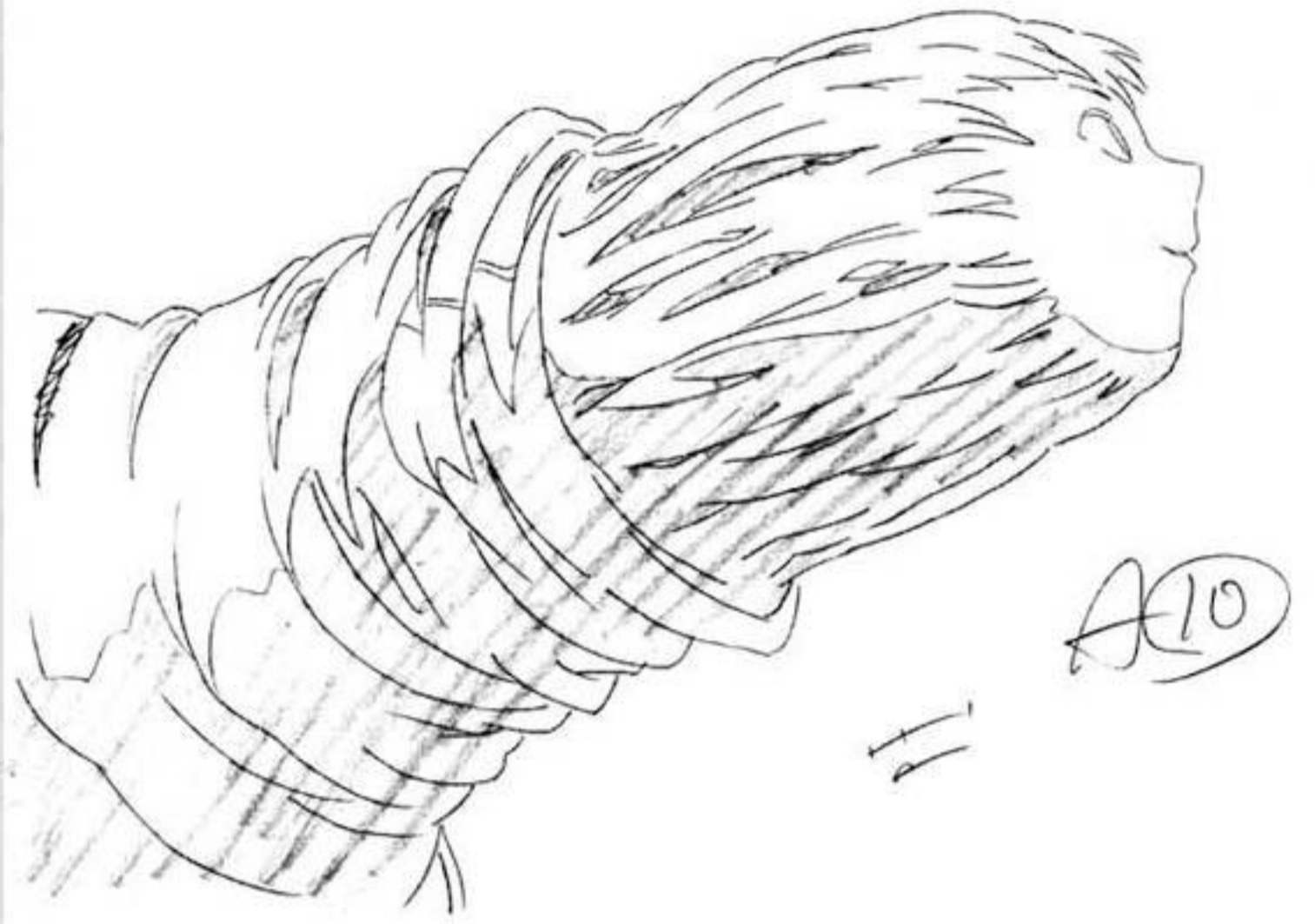

A10

修正原画

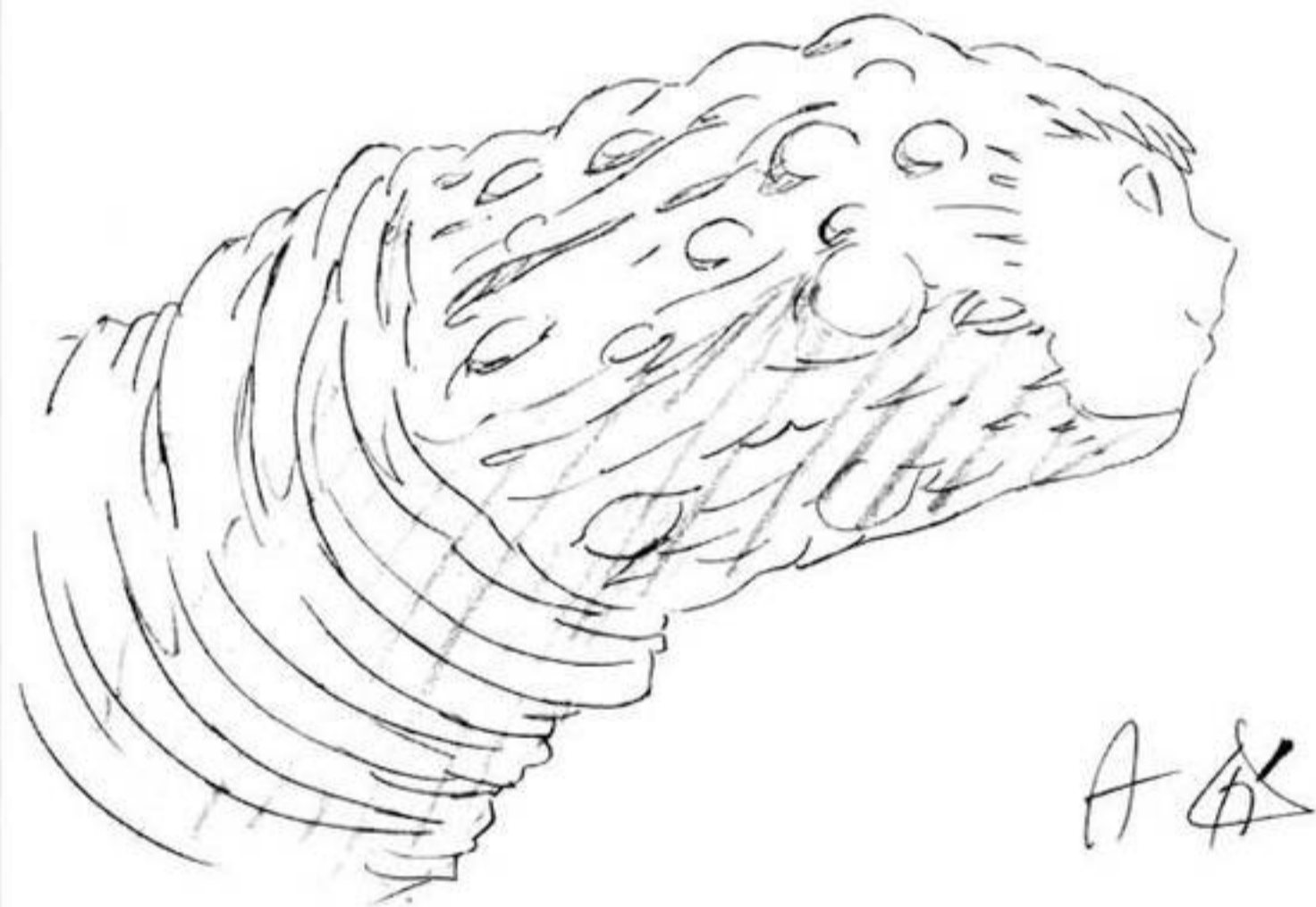

A 4

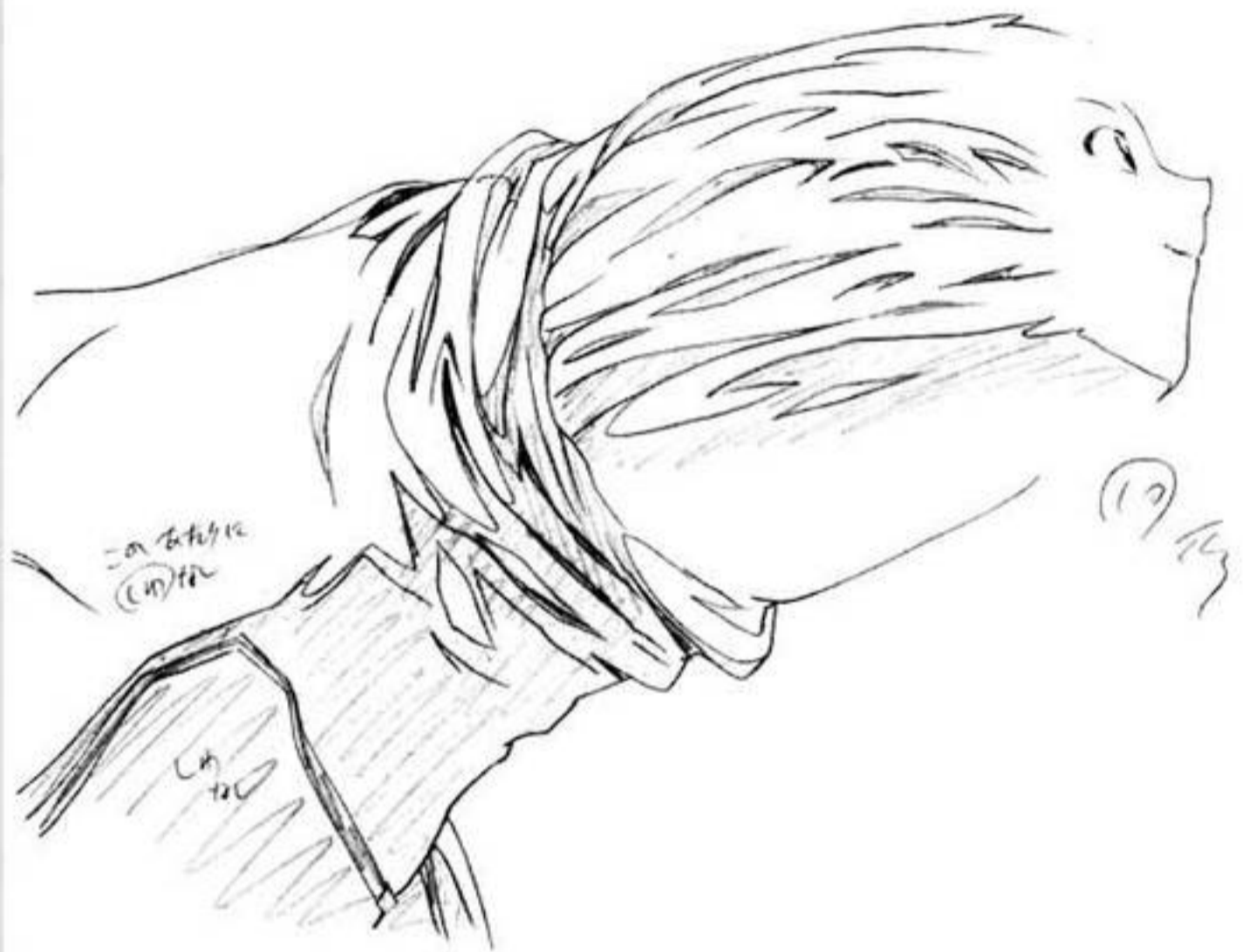

(17) 15

修正原画



チヤン

チヤン

(17) 15

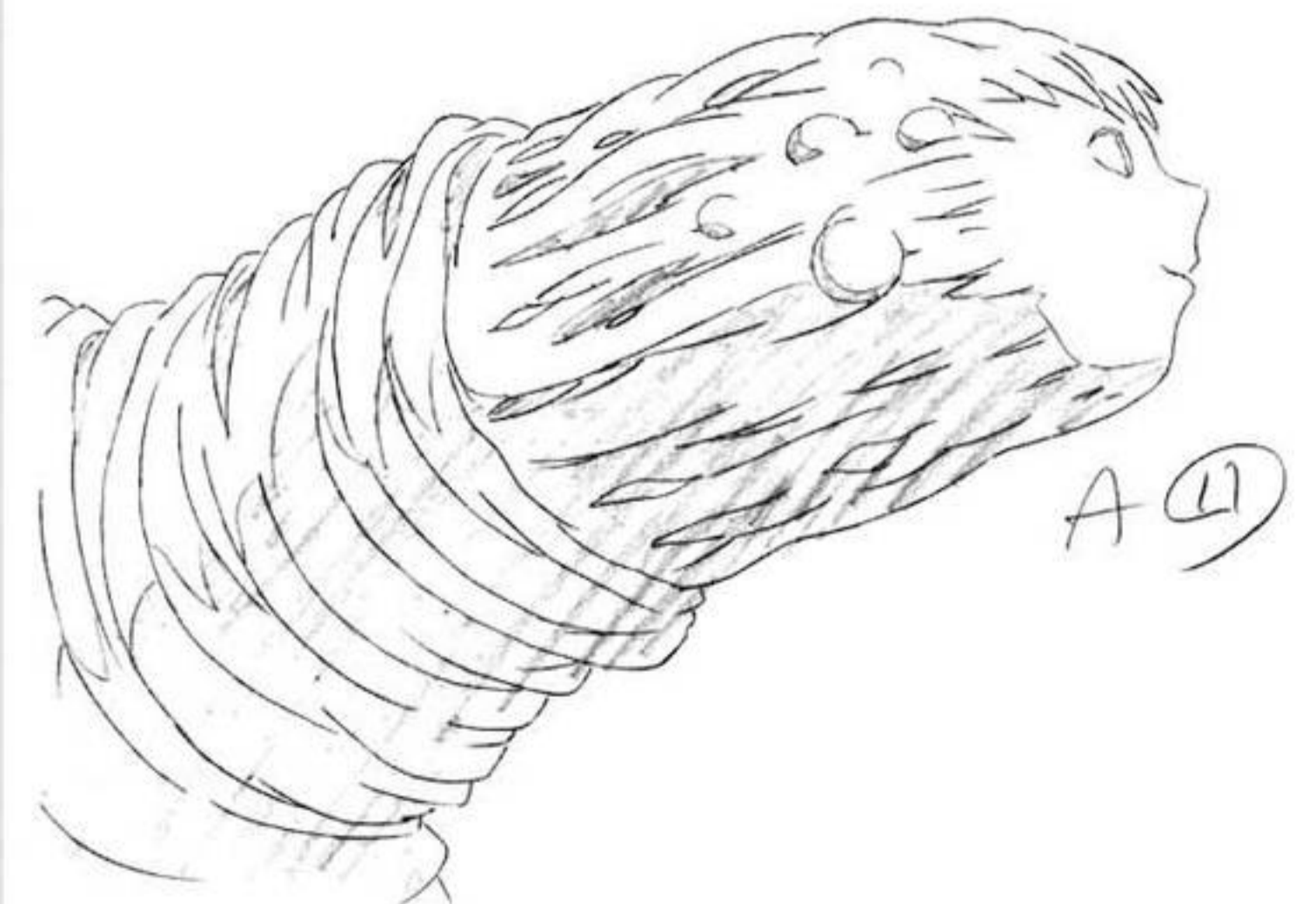

A 4

修正原画

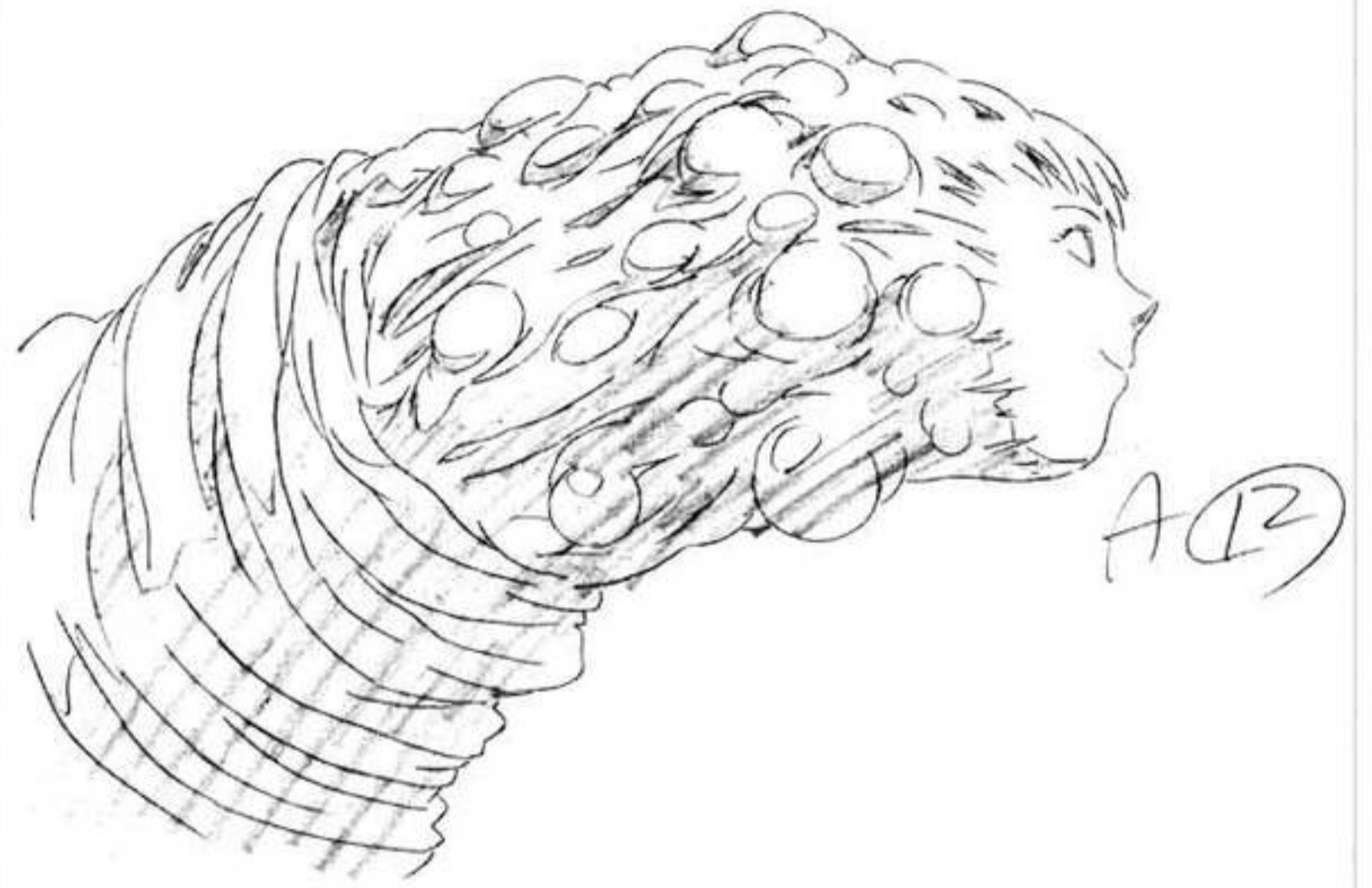

修正原画



修正原画

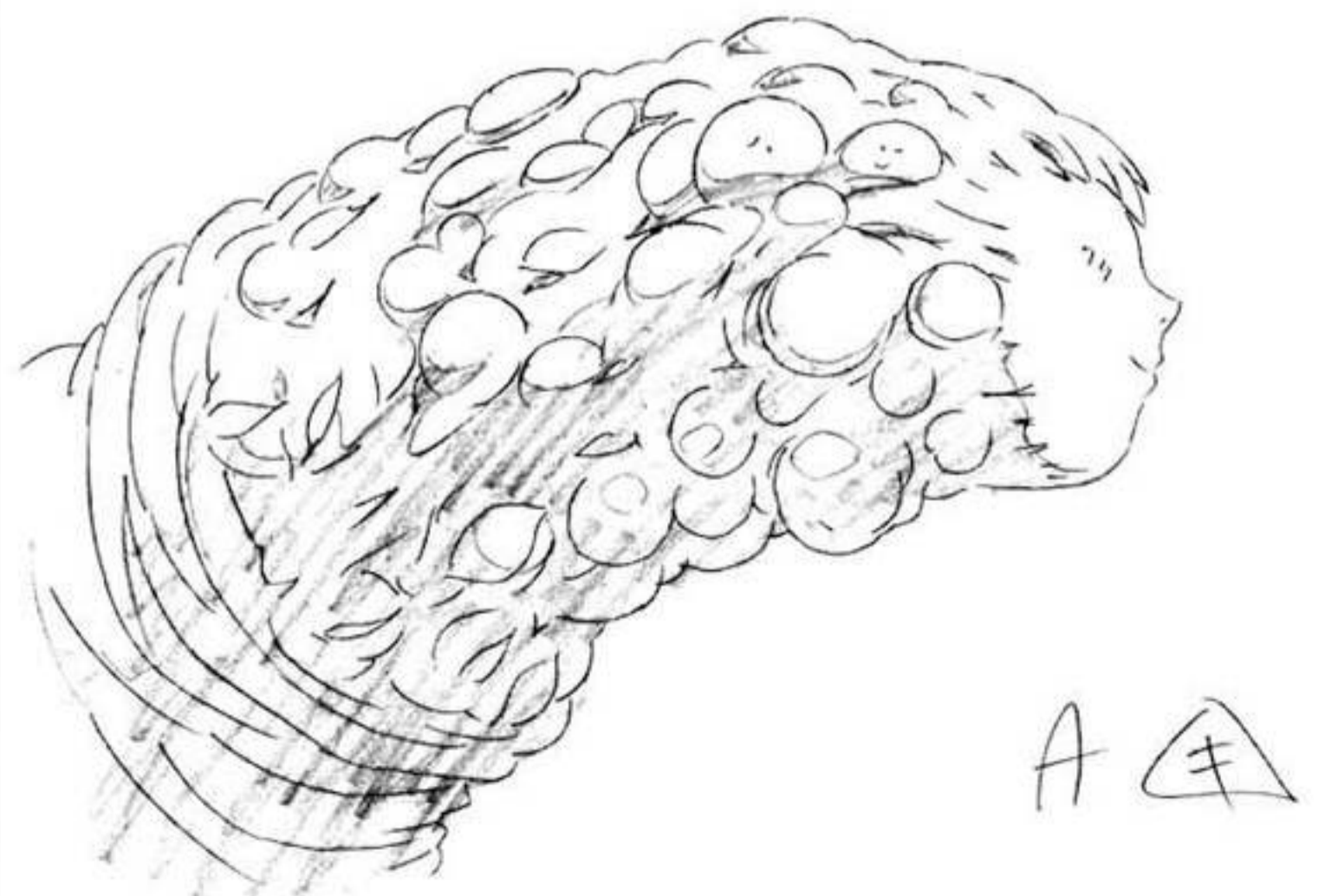
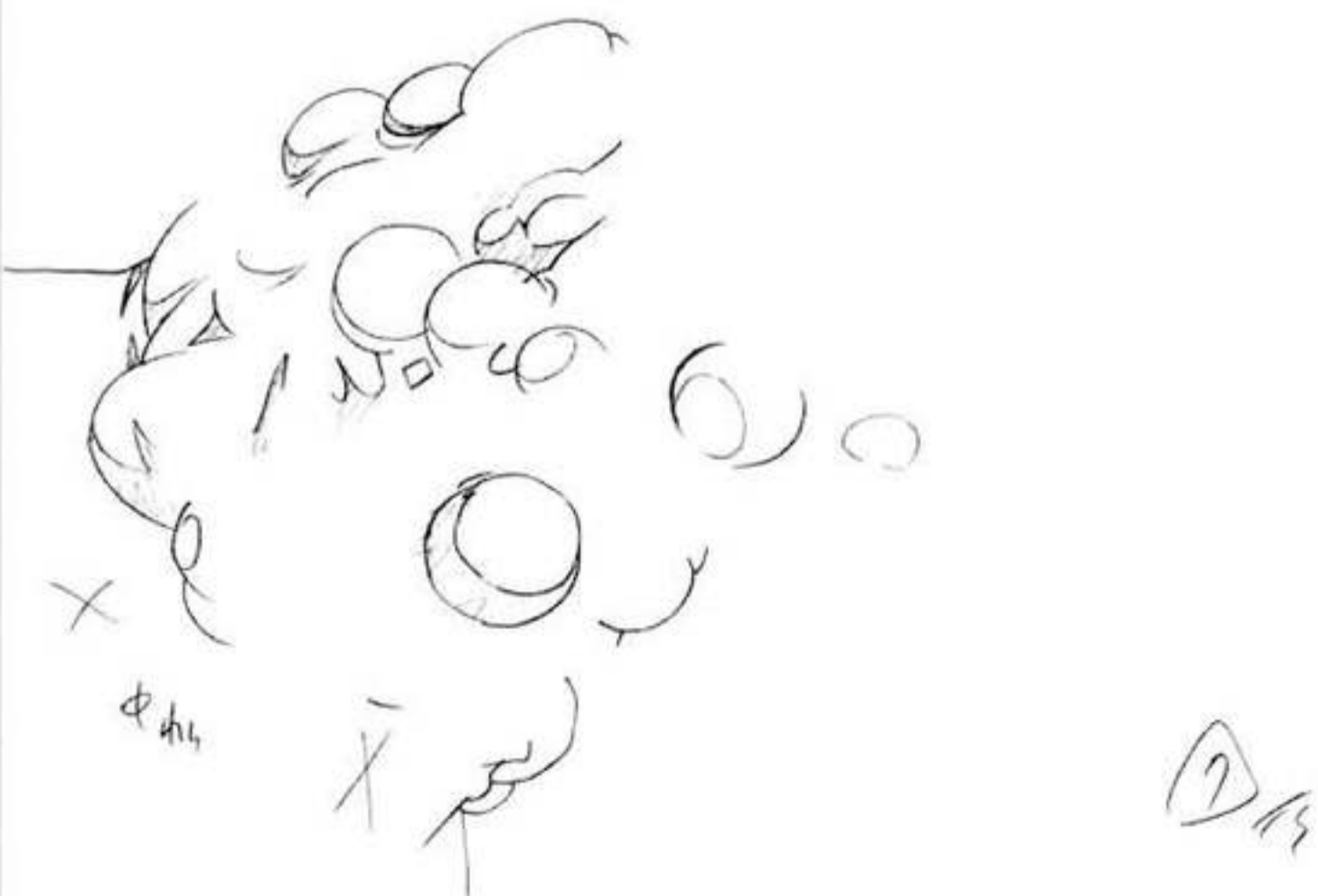

修正原画



14/13

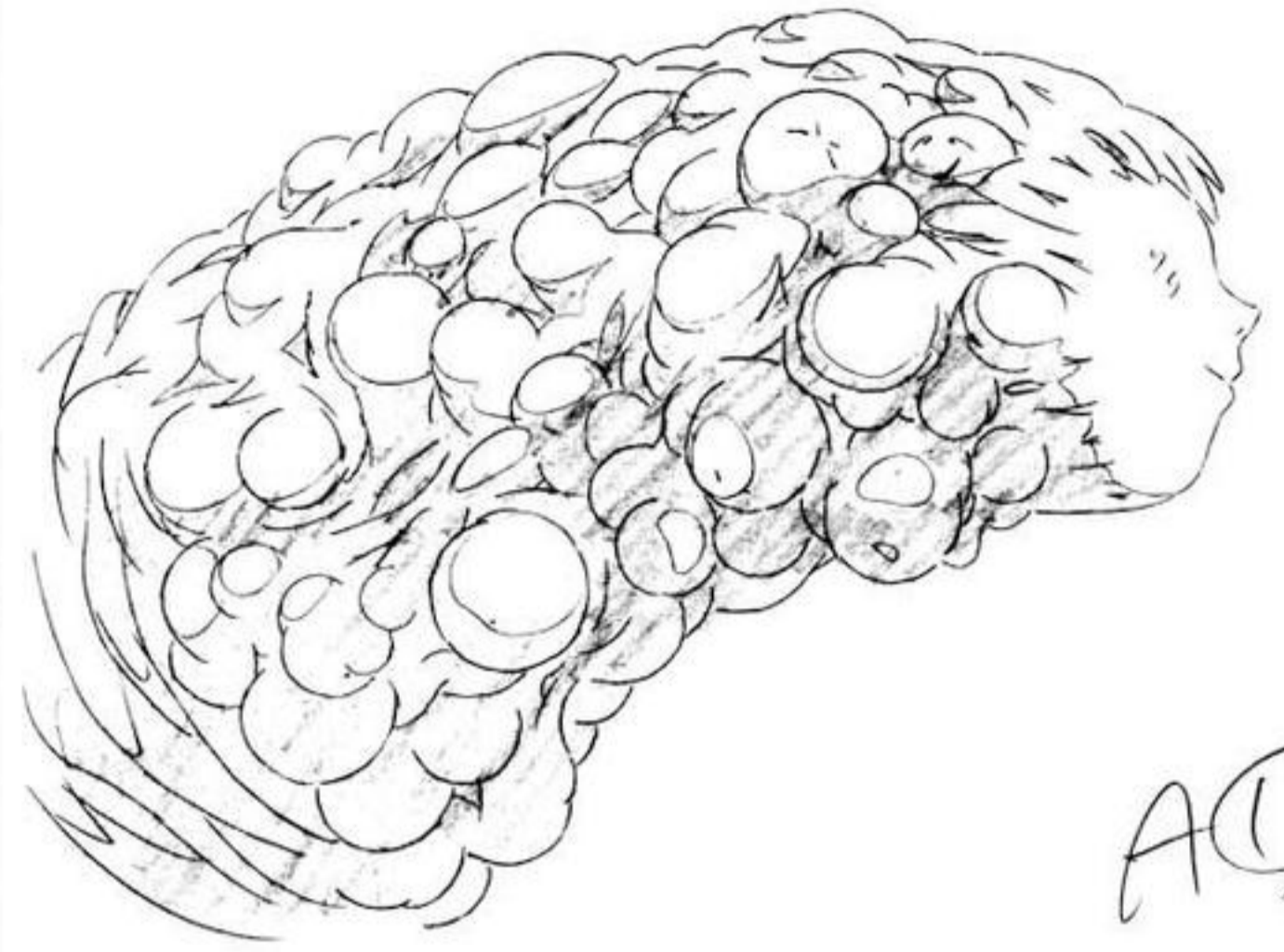

A(13)

修正原画

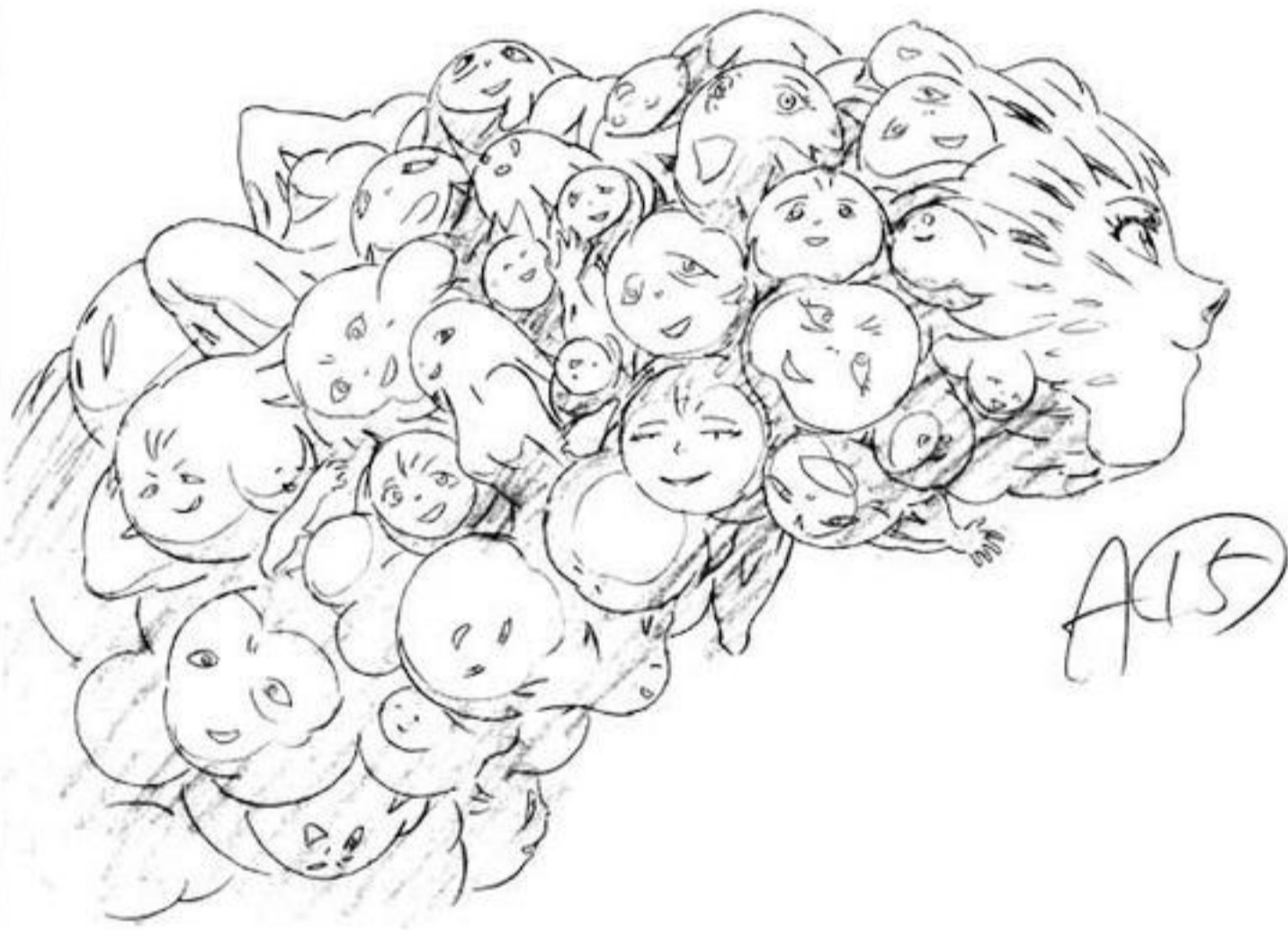

A(15)

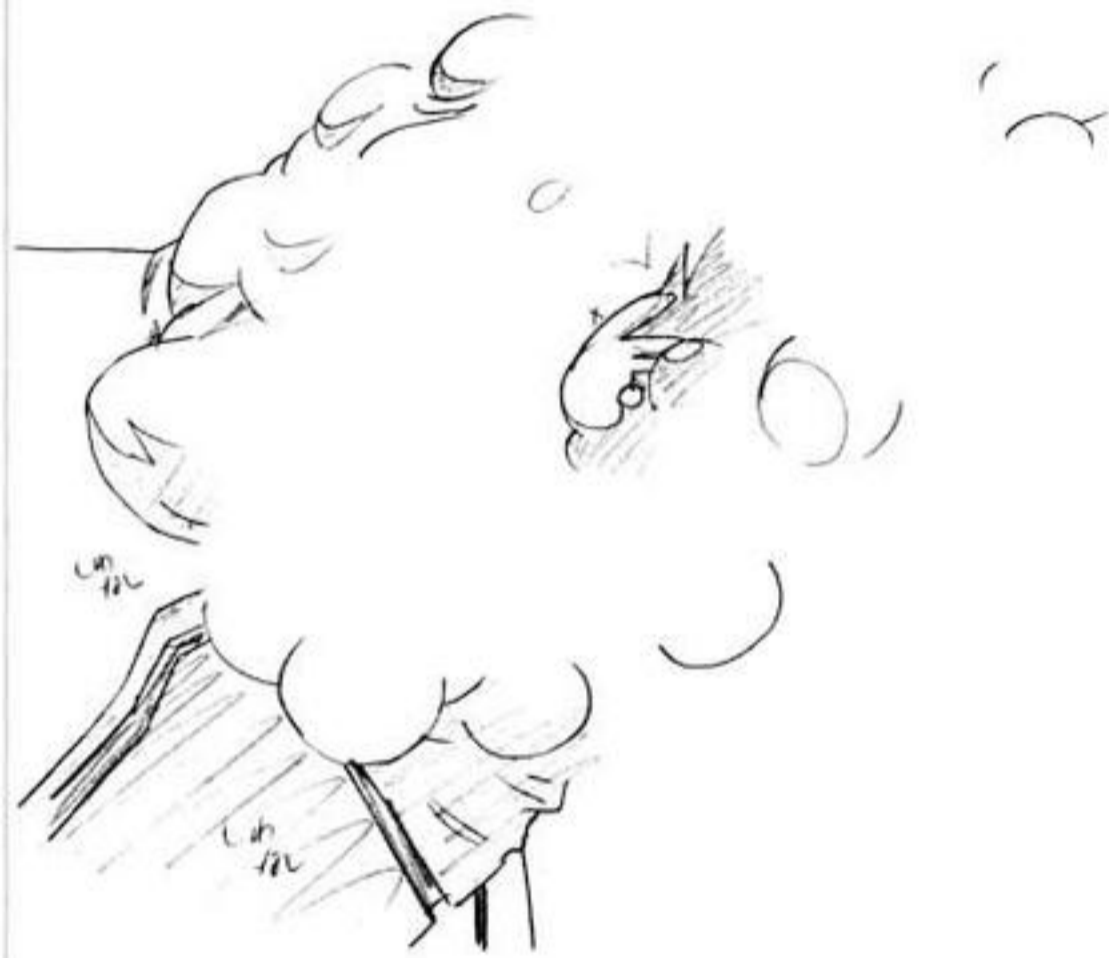

13/13

修正原画

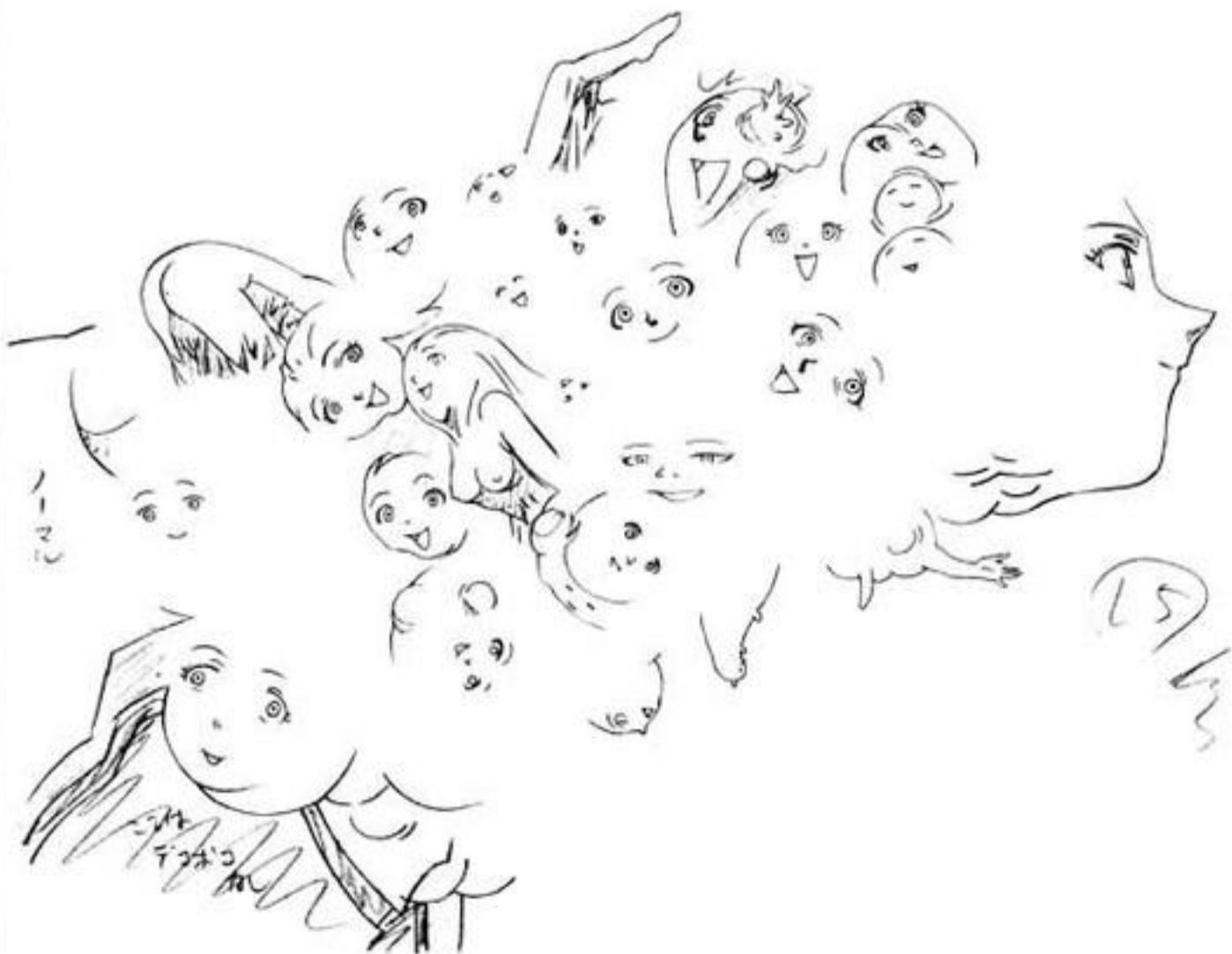

15/13

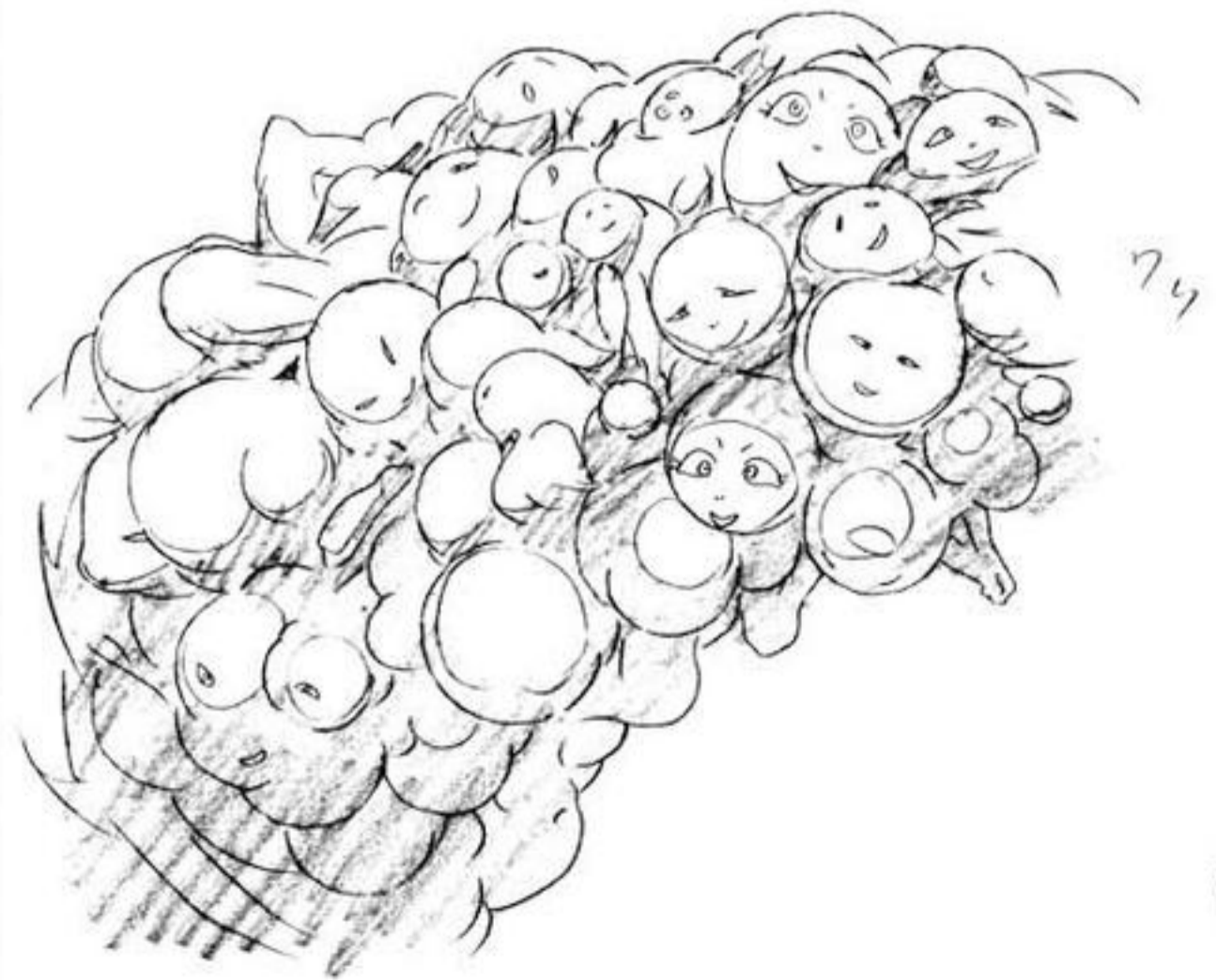

A(14)

修正原画



#26-C143レイアウト時作監修正



「よし虫こばう」加味に
& キー

かや
なるべくシンプルに

これはおまかせ
ガチャガチャ

ア.) 様 ほかの外にどうするか?

野田様. 4/10に電話してお話しして

#26-C143作監修正済レイアウト時演出チェック



バランスがええ感じのも
よろしく。

17年117年の笑顔でよろしく

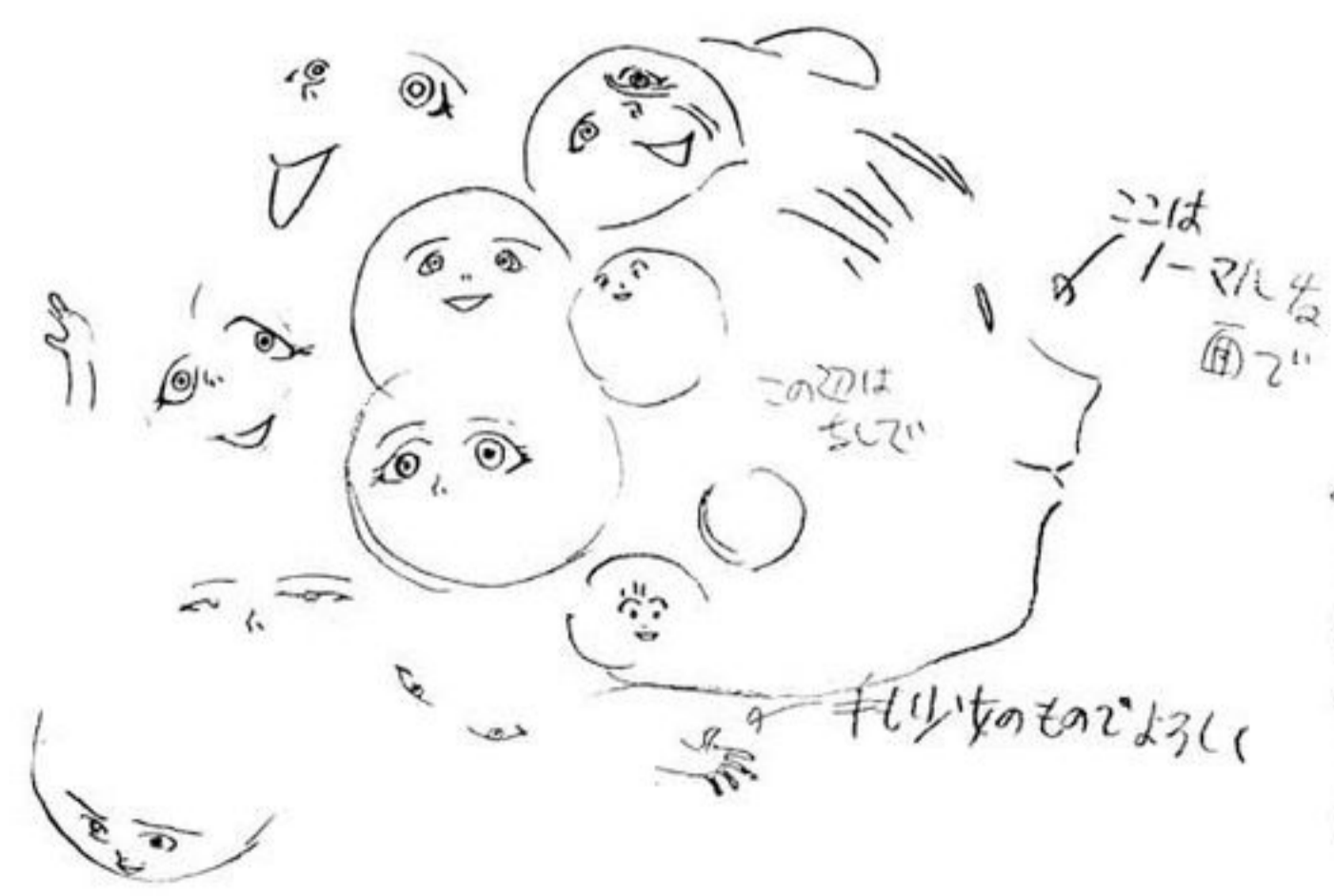

これは
「マシな
面だ」

おまかせの笑顔でよろしく

おまかせ。おまかせ
美少女のイメージというか
面が"を"よろしく。
(記号的な美少女がゆがんだ
感じ)



#26-C144,145B
レイアウト

#26-C145レイアウト



AB		
①		
②		2
③		4
④		6
⑤		8
⑥		10
⑦		12
⑧		14
⑨		16
⑩		18
⑪		20
⑫		22
⑬		24
⑭		26
⑮		28
⑯		30
⑰		32
⑱		34
⑲		36
⑳		38
㉑		40
㉒		42
㉓		44
㉔		46
㉕		48
AB		
①		
②		50
③		52
④		54
⑤		56
⑥		58
⑦		60
⑧		62
⑨		64
⑩		66
⑪		68
⑫		70
⑬		72
⑭		74
⑮		76
⑯		78
⑰		80
⑱		82
⑲		84

A(1)
A(1)
①②③
④⑤

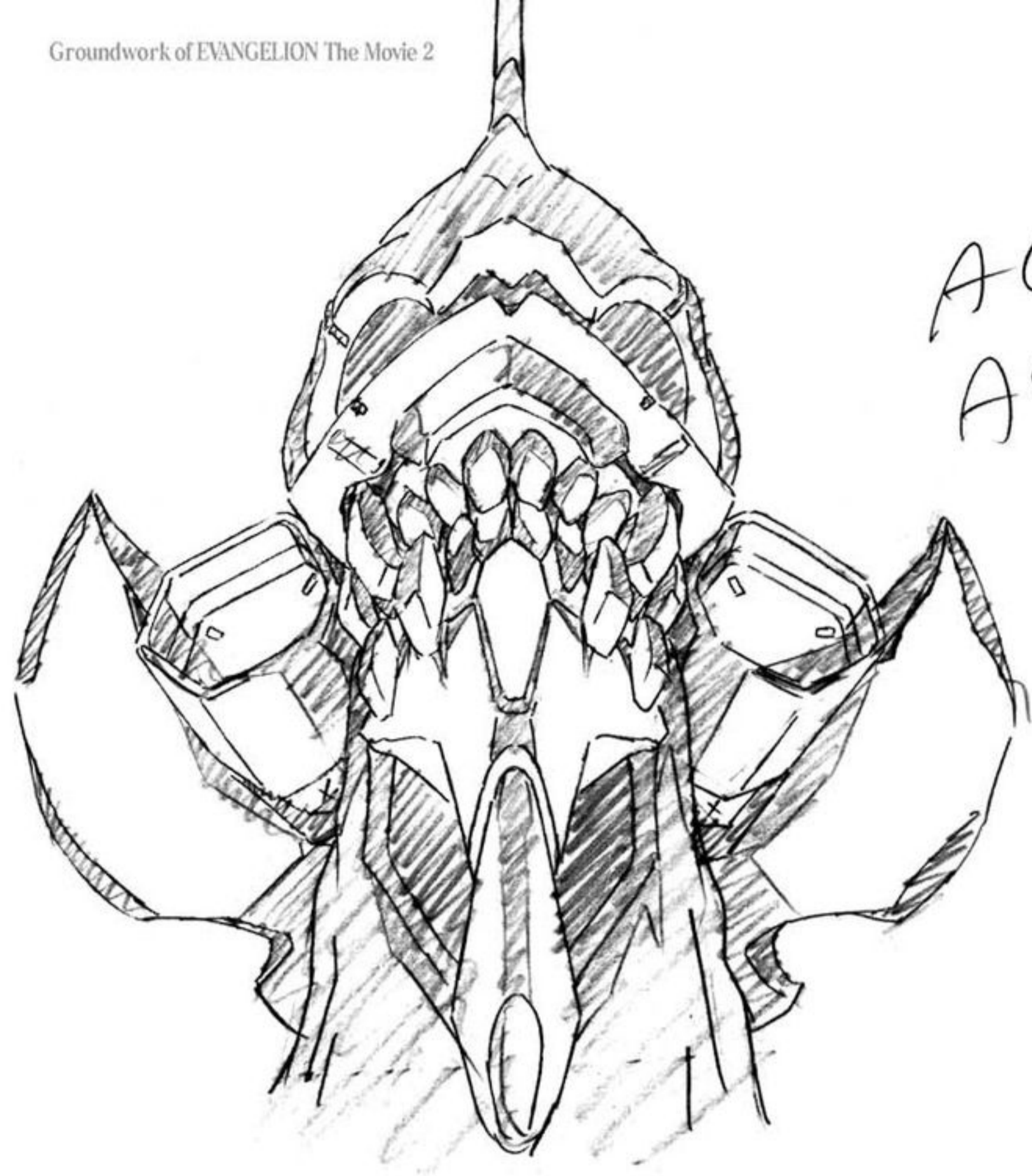

タイムシート

①②③
④⑤⑥⑦⑧⑨⑩

A(2)





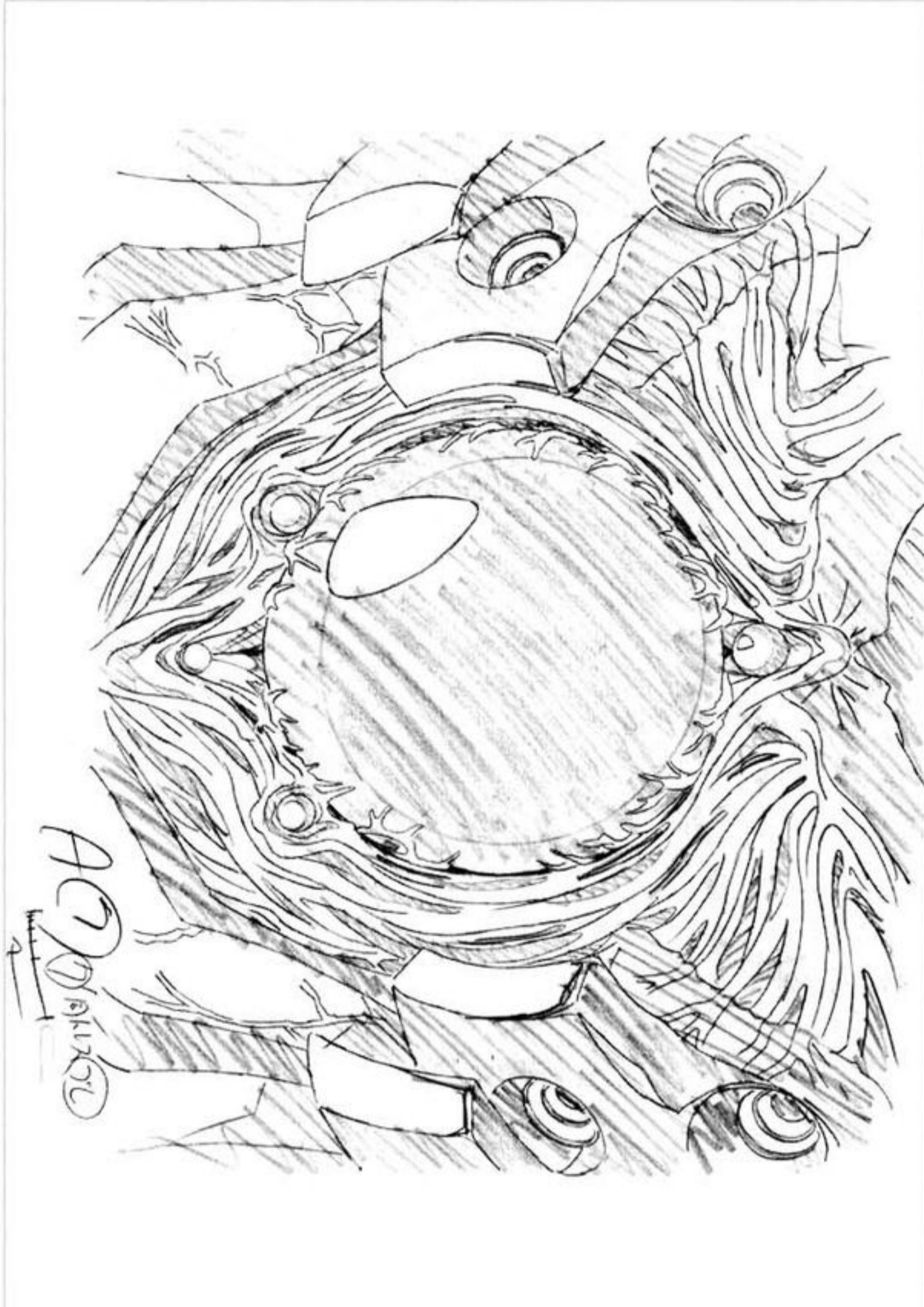

A①



修正原画



A③

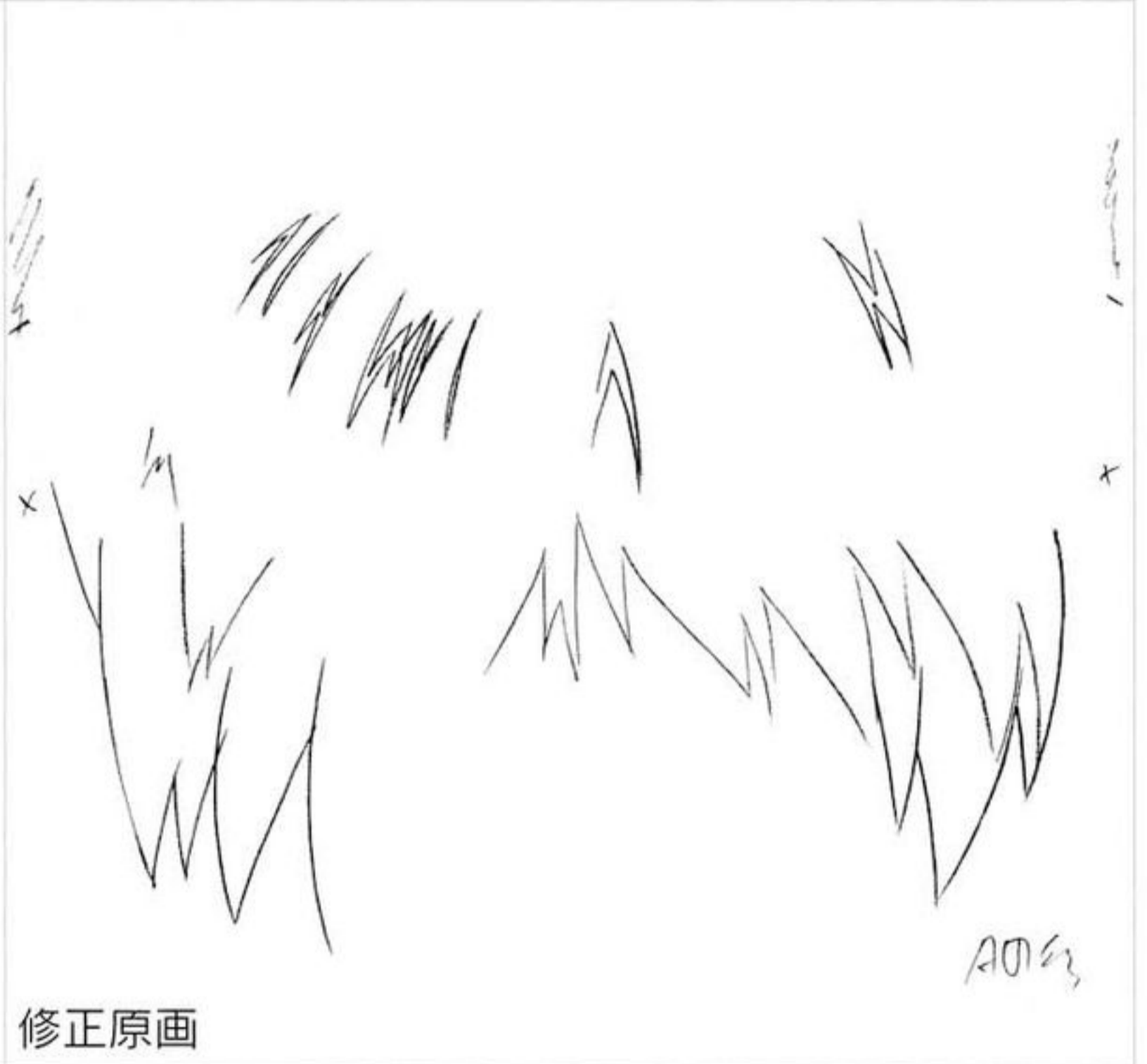

修正原画

A④



修正原画

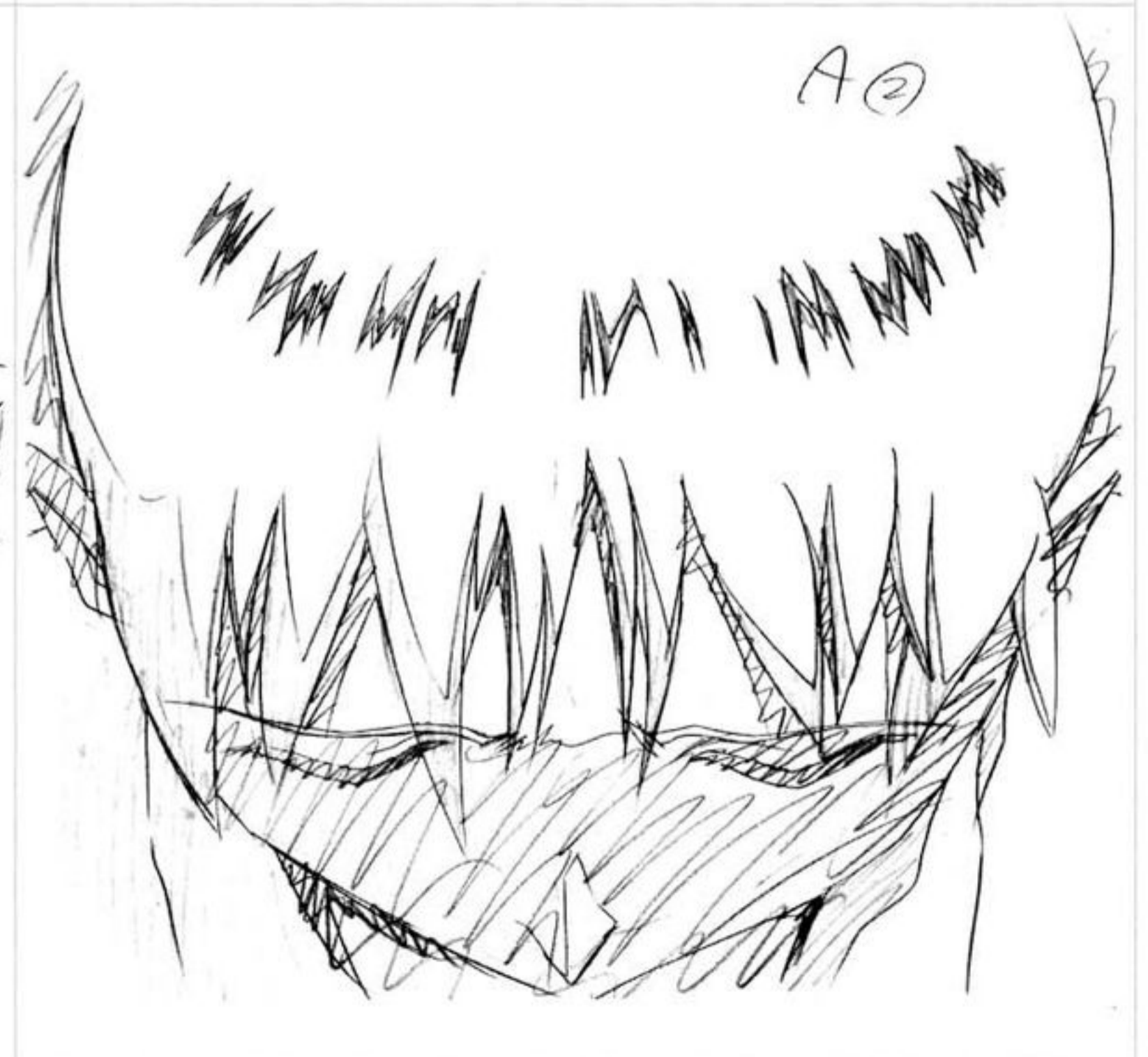

A②

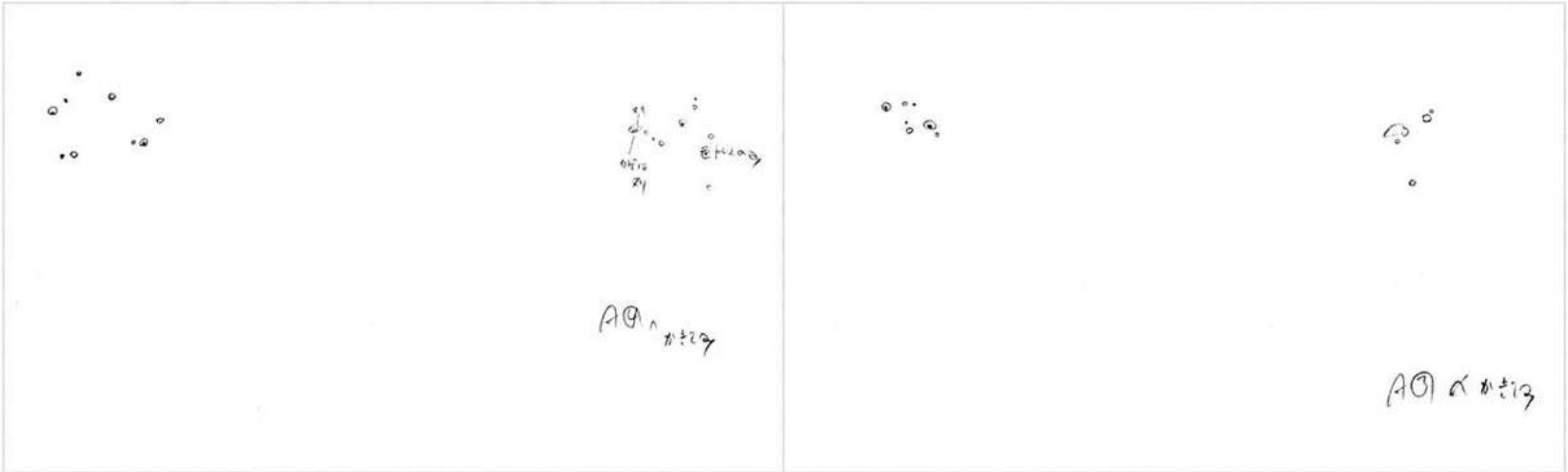

作画監督用演出指示



A9 11/29

修正原画

ADex



修正原画

ADex



#26-C156, 158, 160

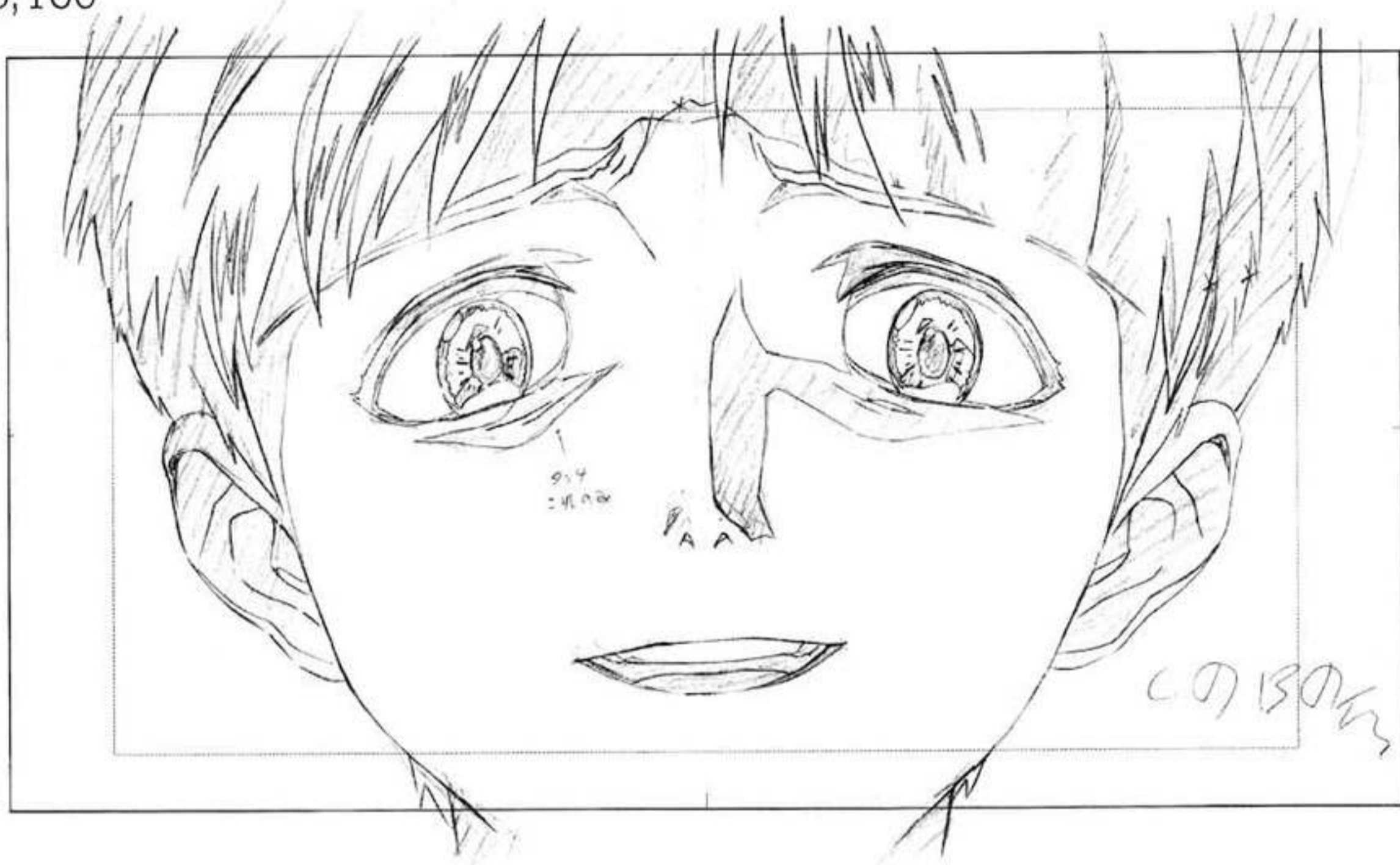

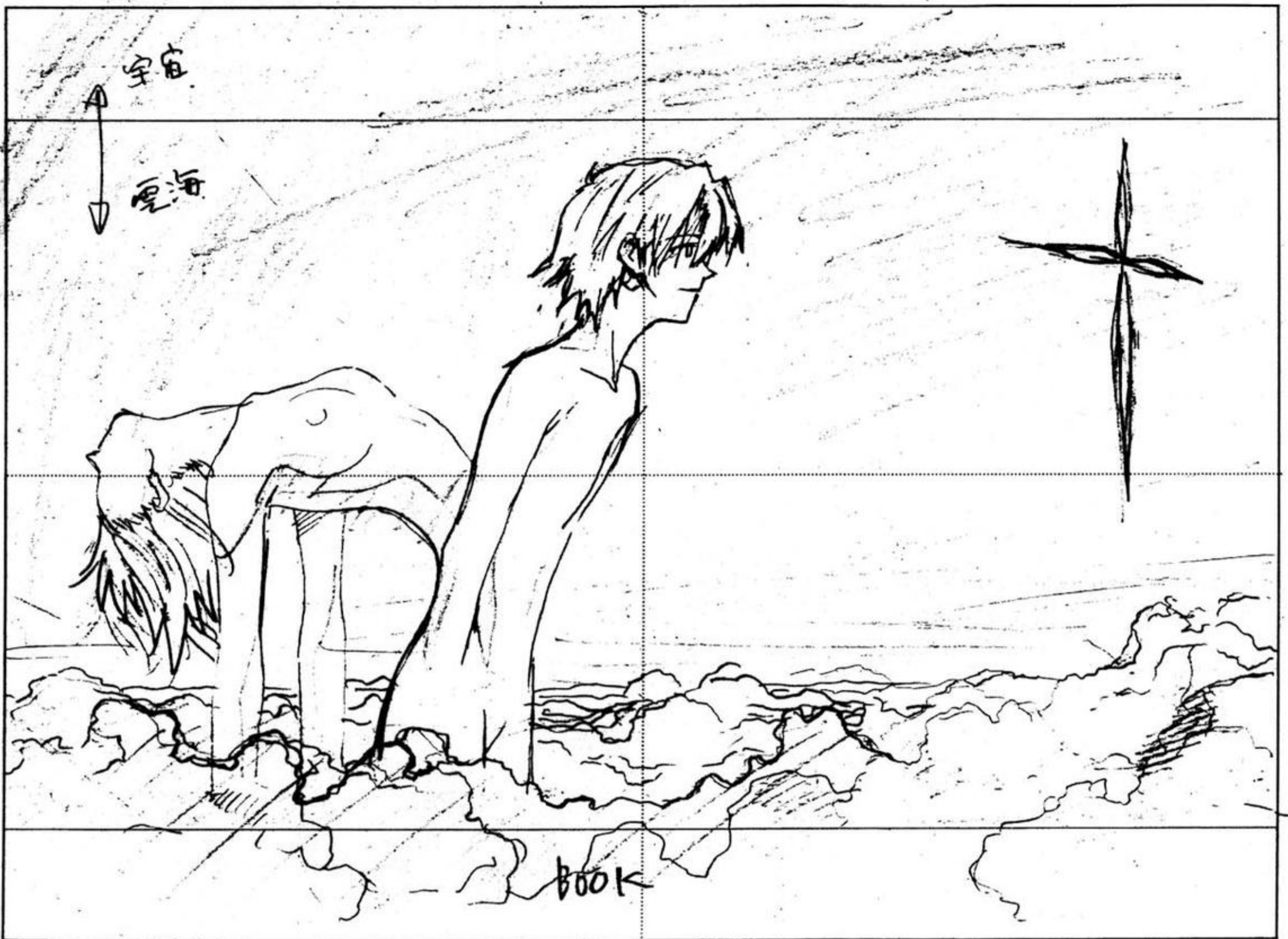

#26-C157レイアウト

4A20



#26-C157

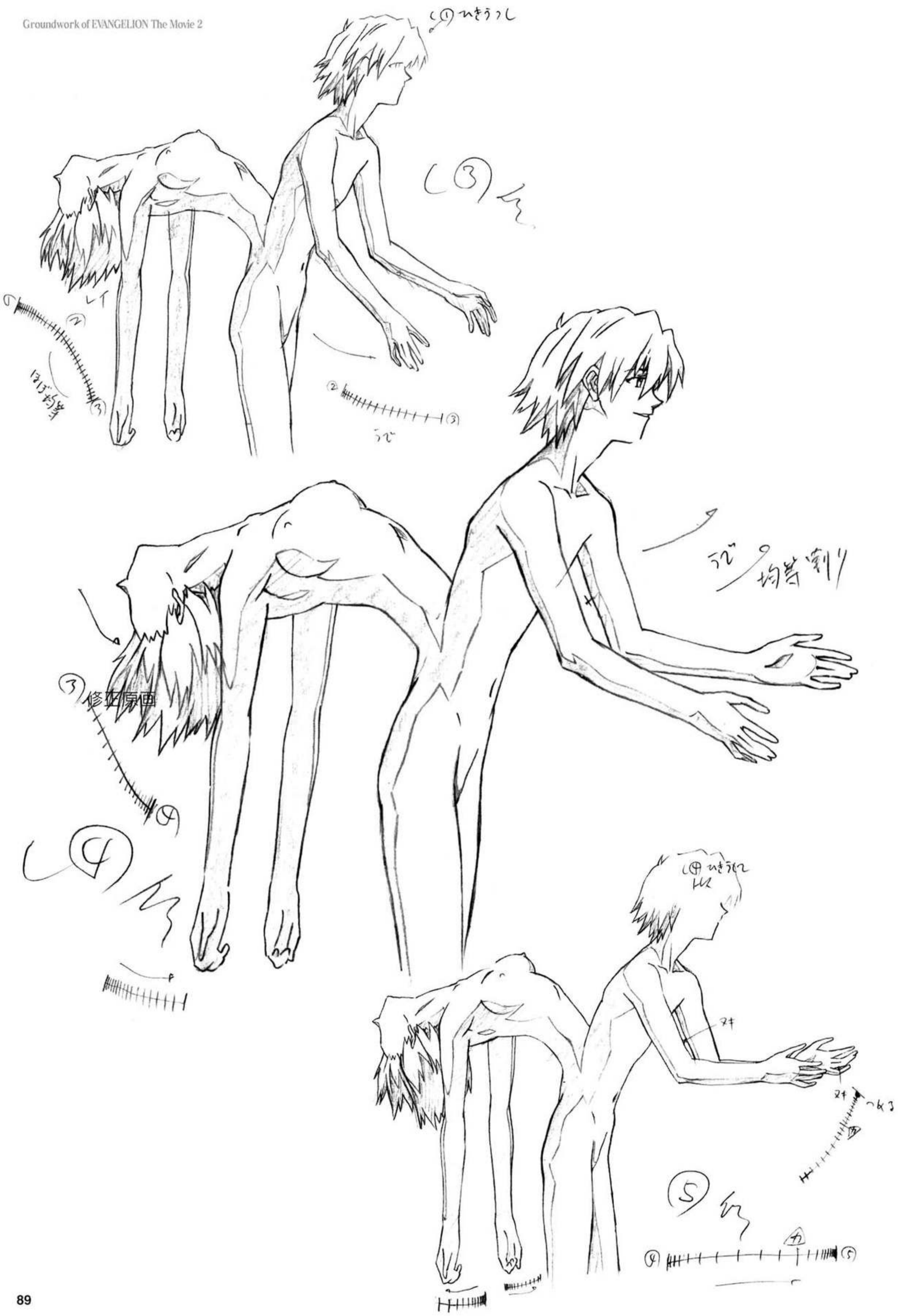

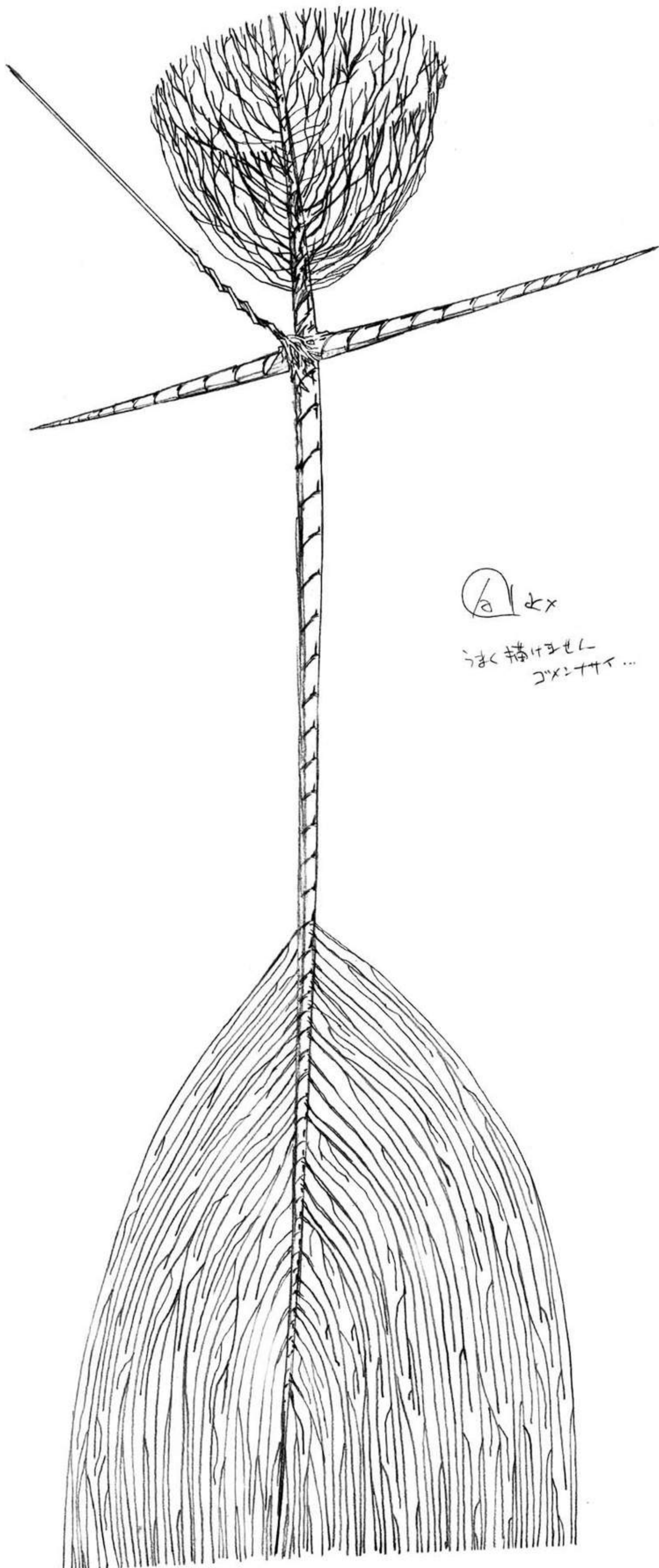

① 女x

はく 掃け玉せし
ゴクニナヤ...



#26-C169

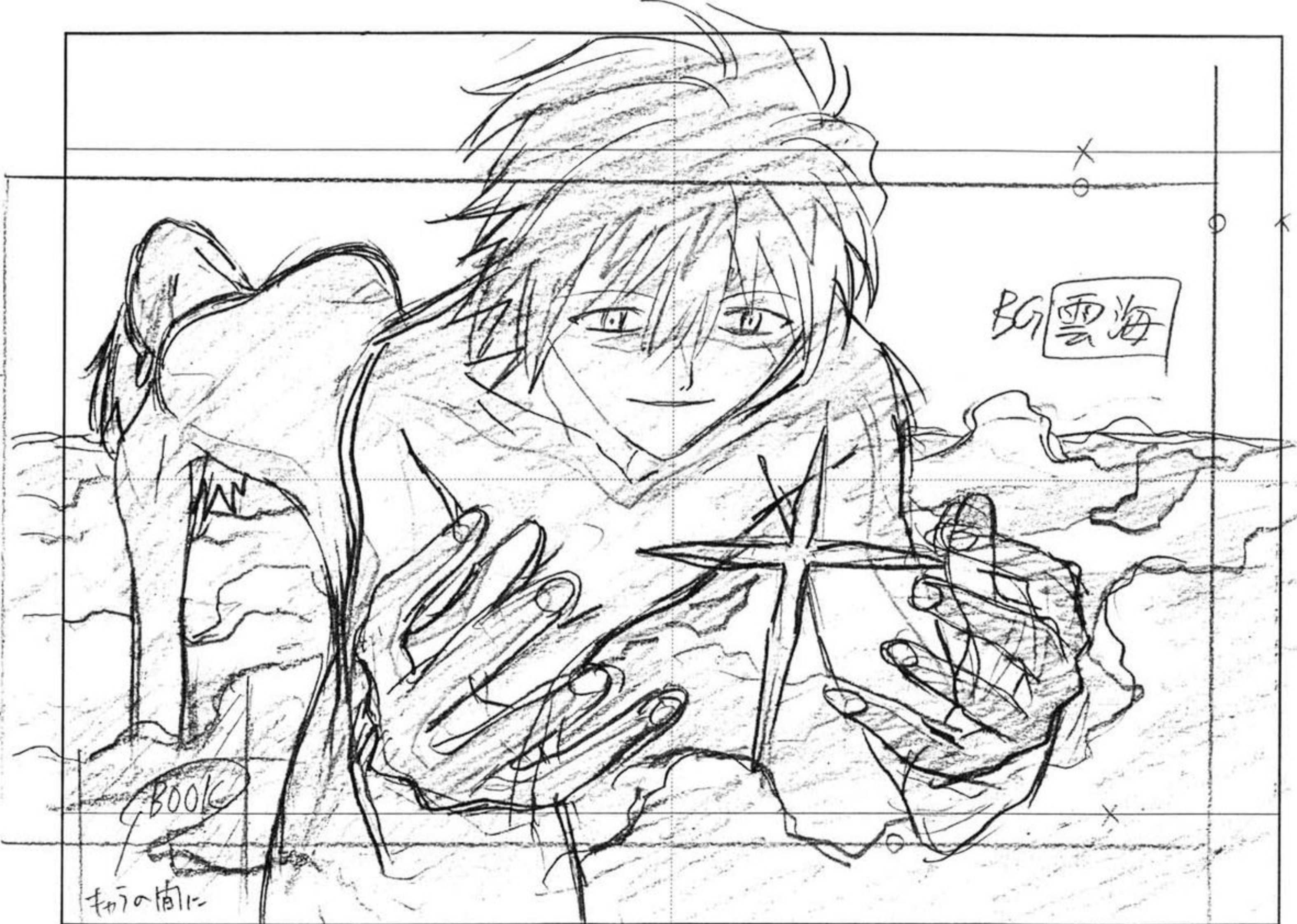

#26-C173レイアウト



#26-C174

B(1)
2
3

A1

12
0117



#26-C174レイアウト



この髪は髪の色を
1111 髪.....

二人は風にかいれや?を直さ
マニニかけ生か?

#26-C176

Fe-2 (27)

Alba

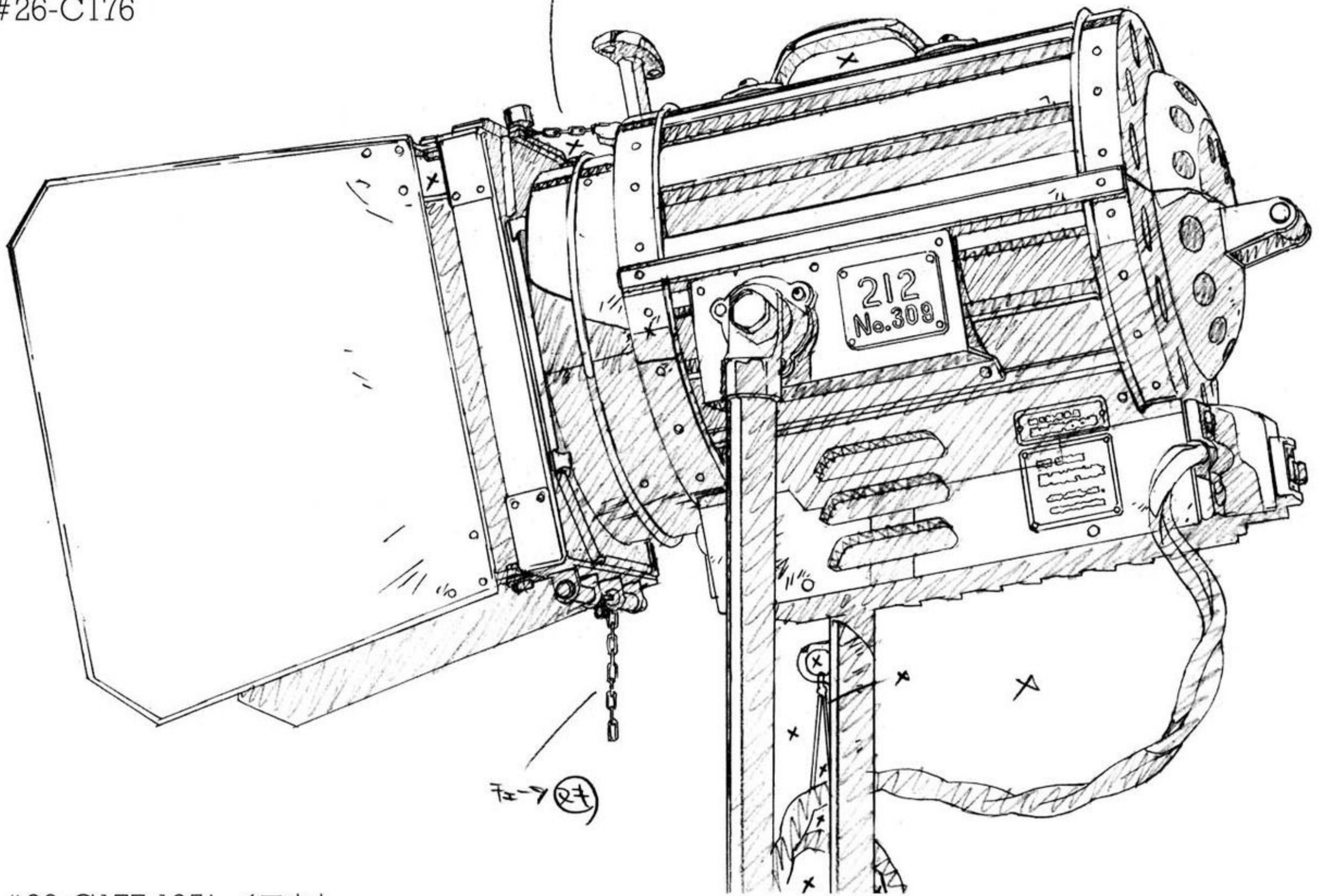

#26-C177, 195レイアウト

○ BGD 夕焼け空

○ BGD 太陽が落ちた色

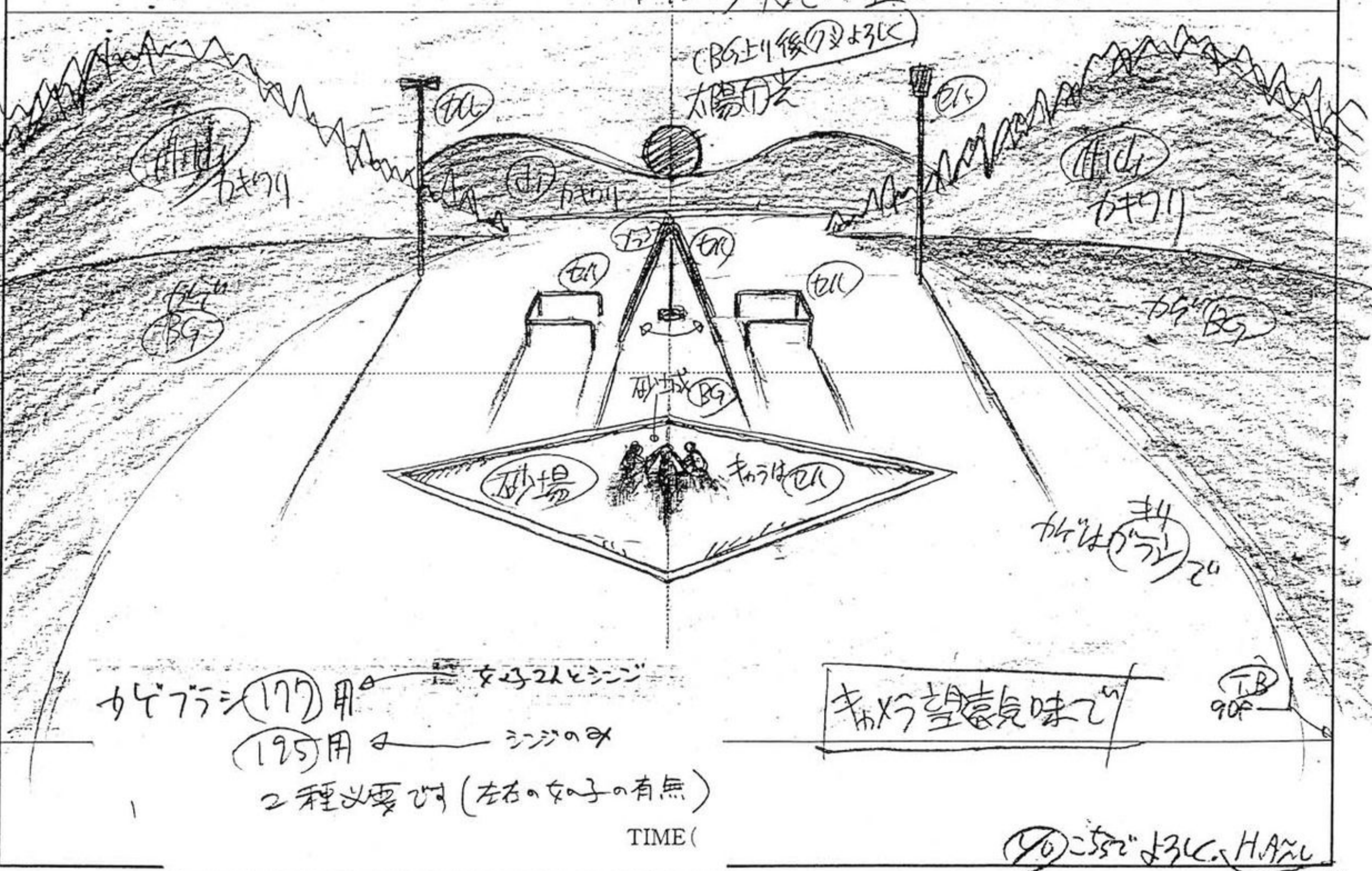

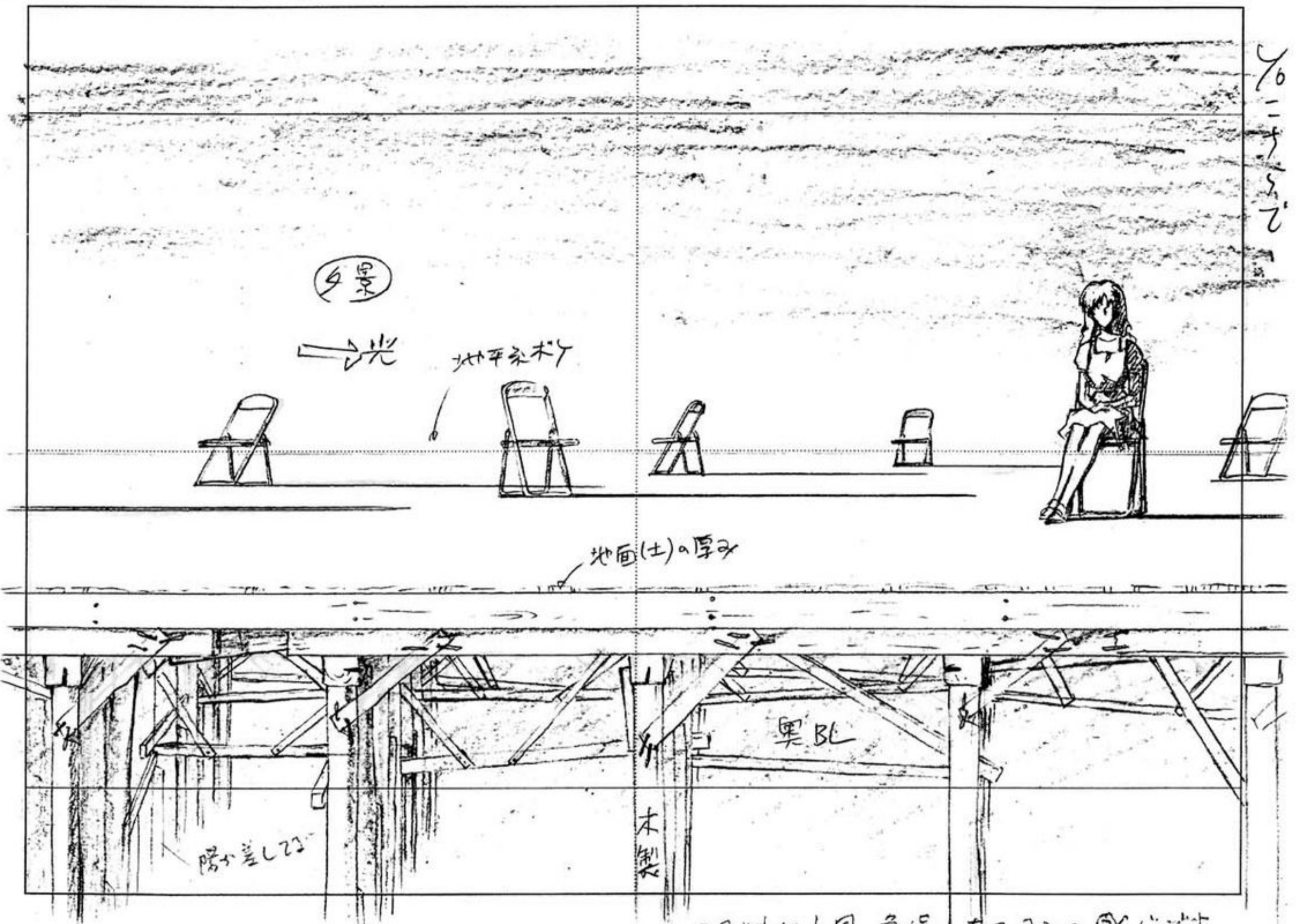

夕景

夕景

→ 光

地平線

地面(土)の厚み

裏BL

木製

陽が差し込む

#26-C182レイアウト

スタジオセット風 急場のため2辺の感じはす

#26-C185レイアウト

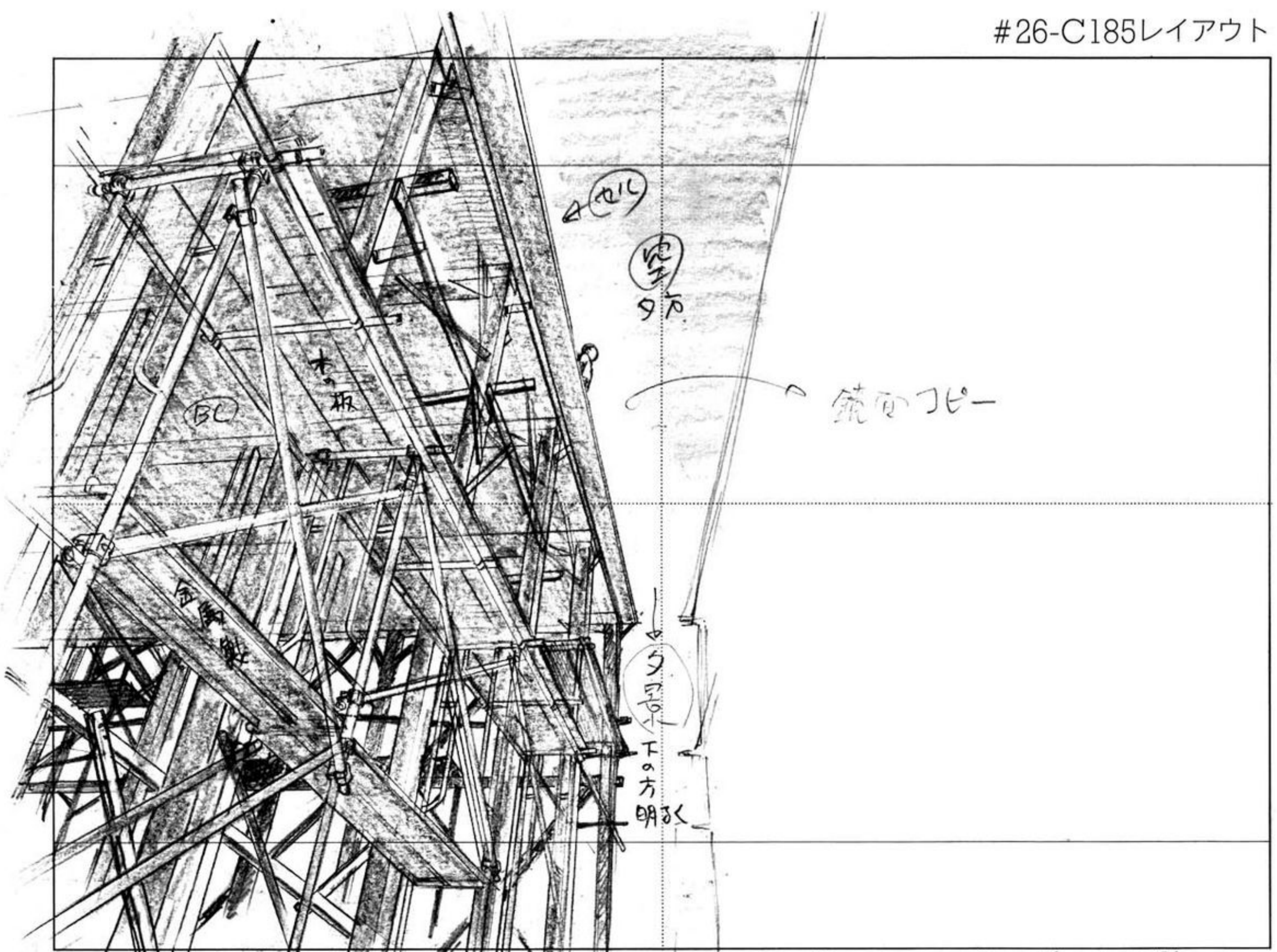

セル

絶景

鏡面コピー

下の方明か

夕景

BL, 44, 1-212, 32x 俵2 ゴヤ とおれんしす



AOM



AOM

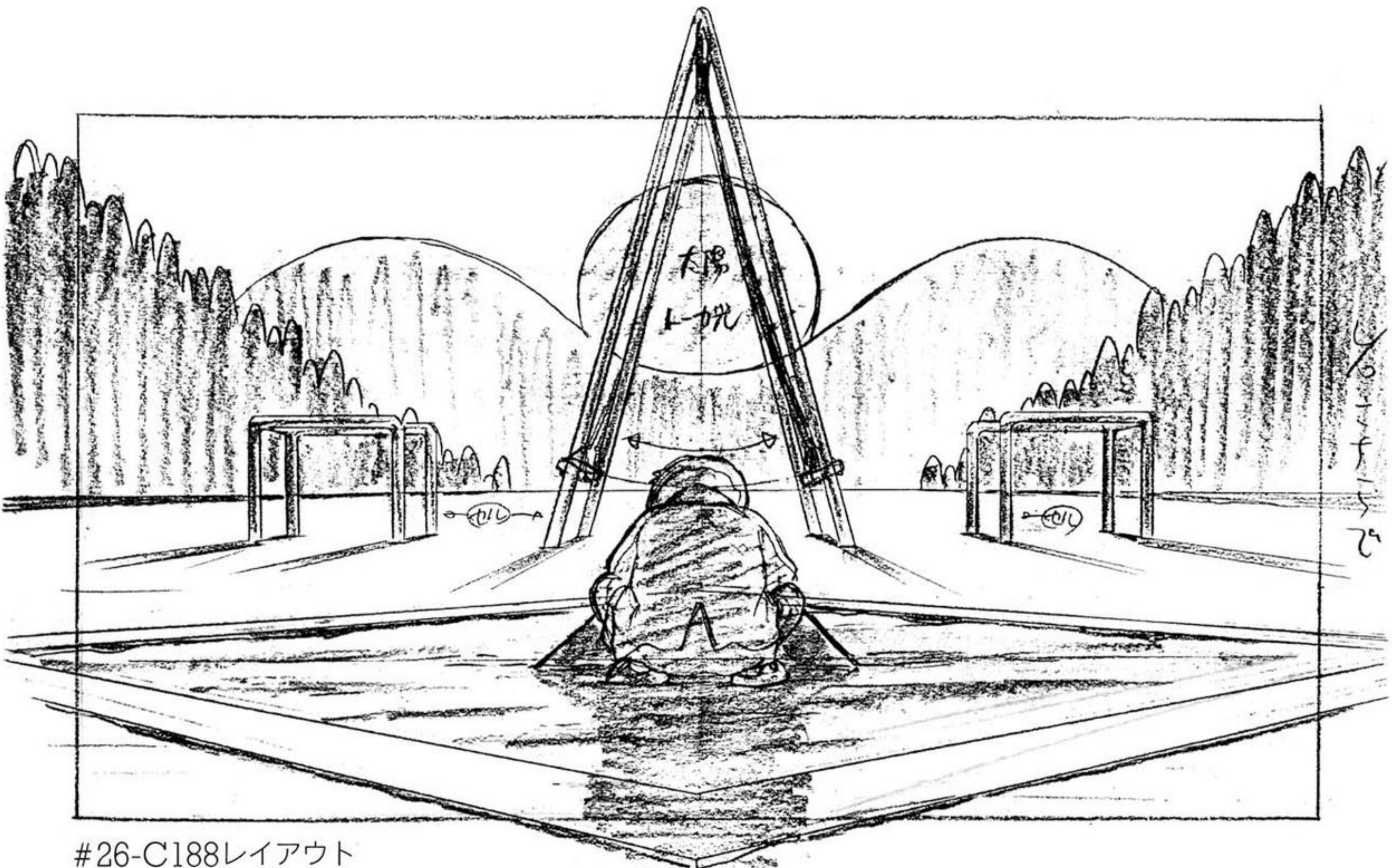

#26-C188レイアウト



#26-C196
レイアウト時
作画監督用演出指示

#26-C196
レイアウト時
作監修正



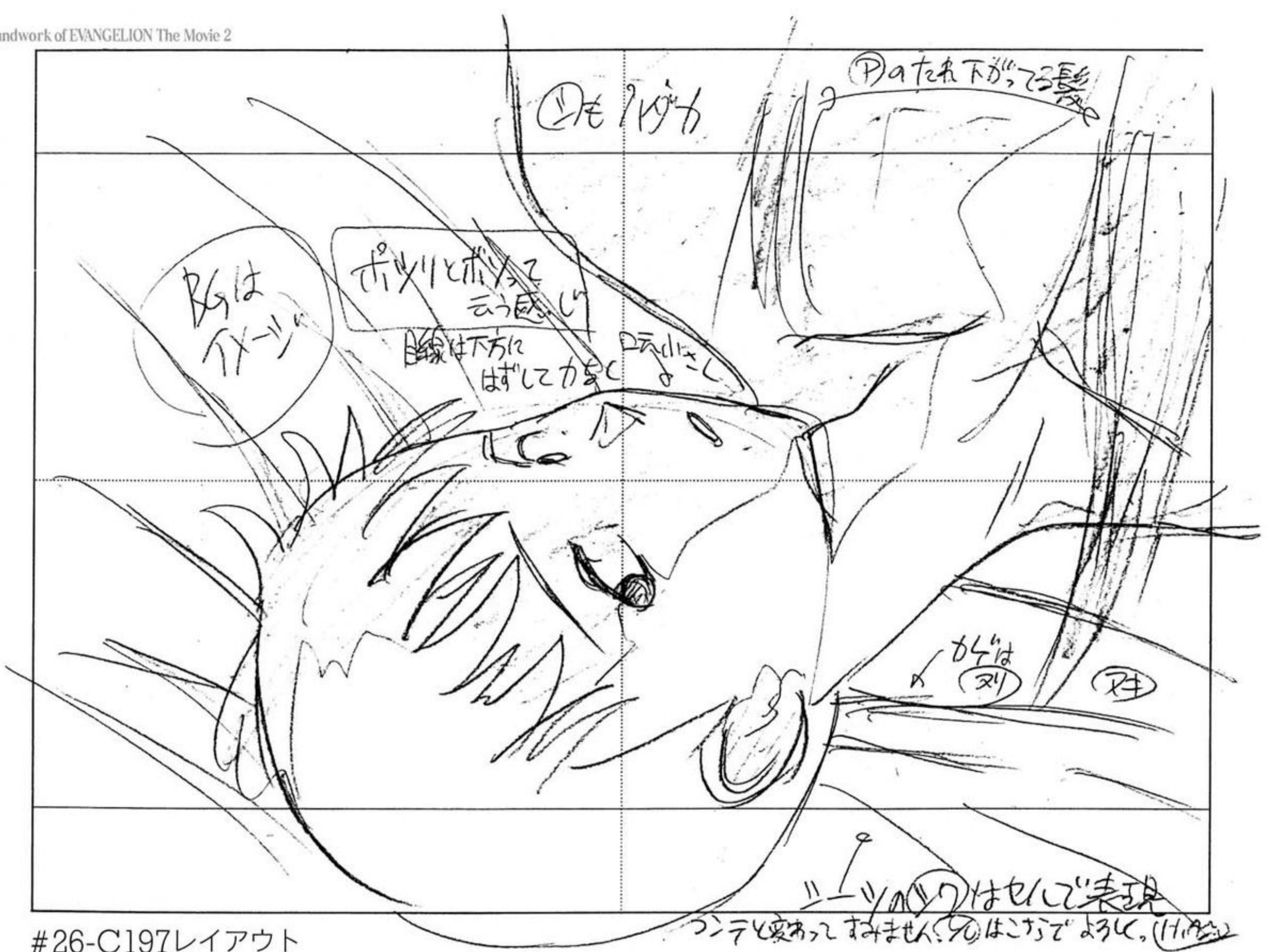

#26-C197レイアウト

#26-C197
レイアウト時作監修正



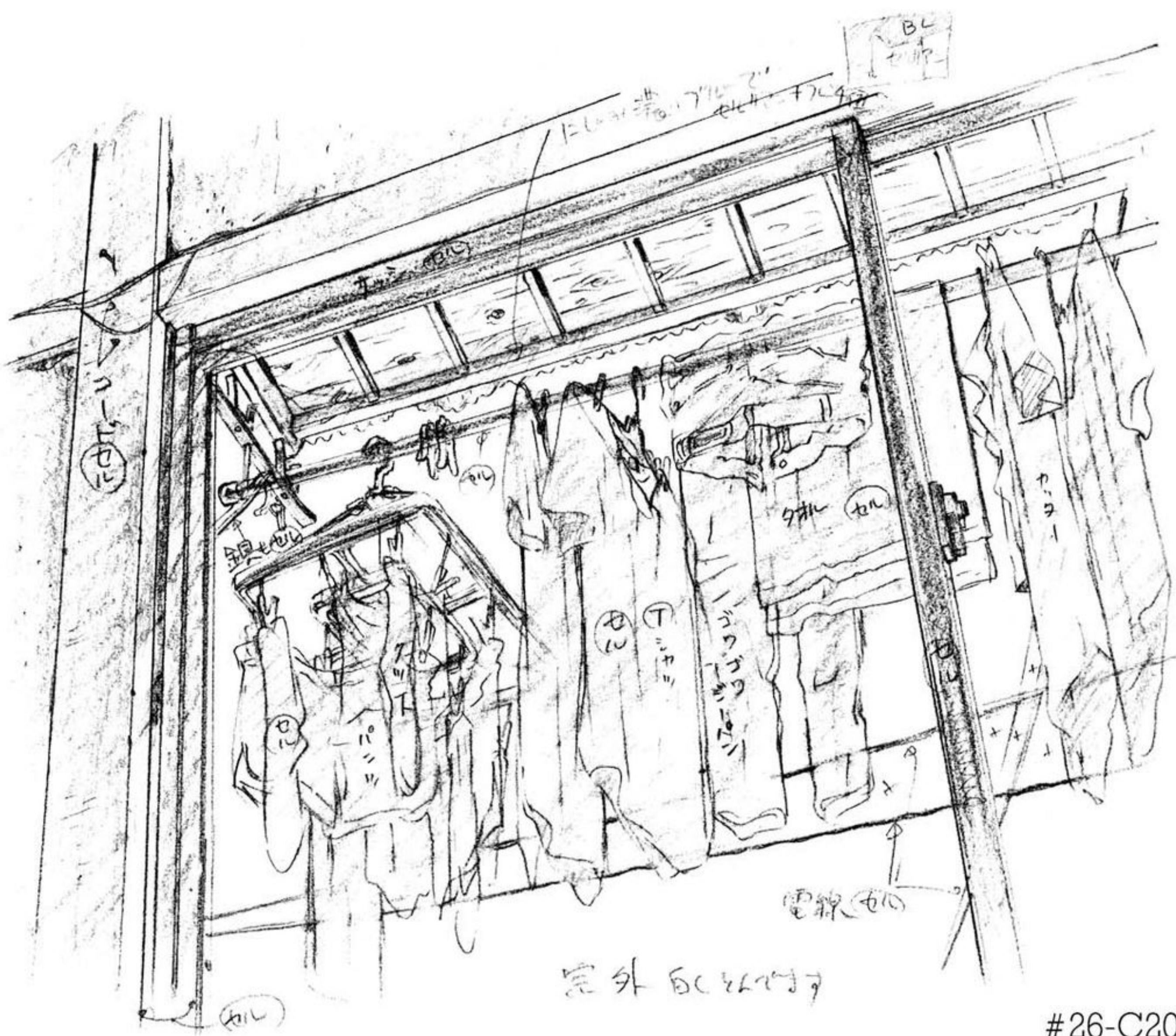

#26-C202レイアウト



#26-C202

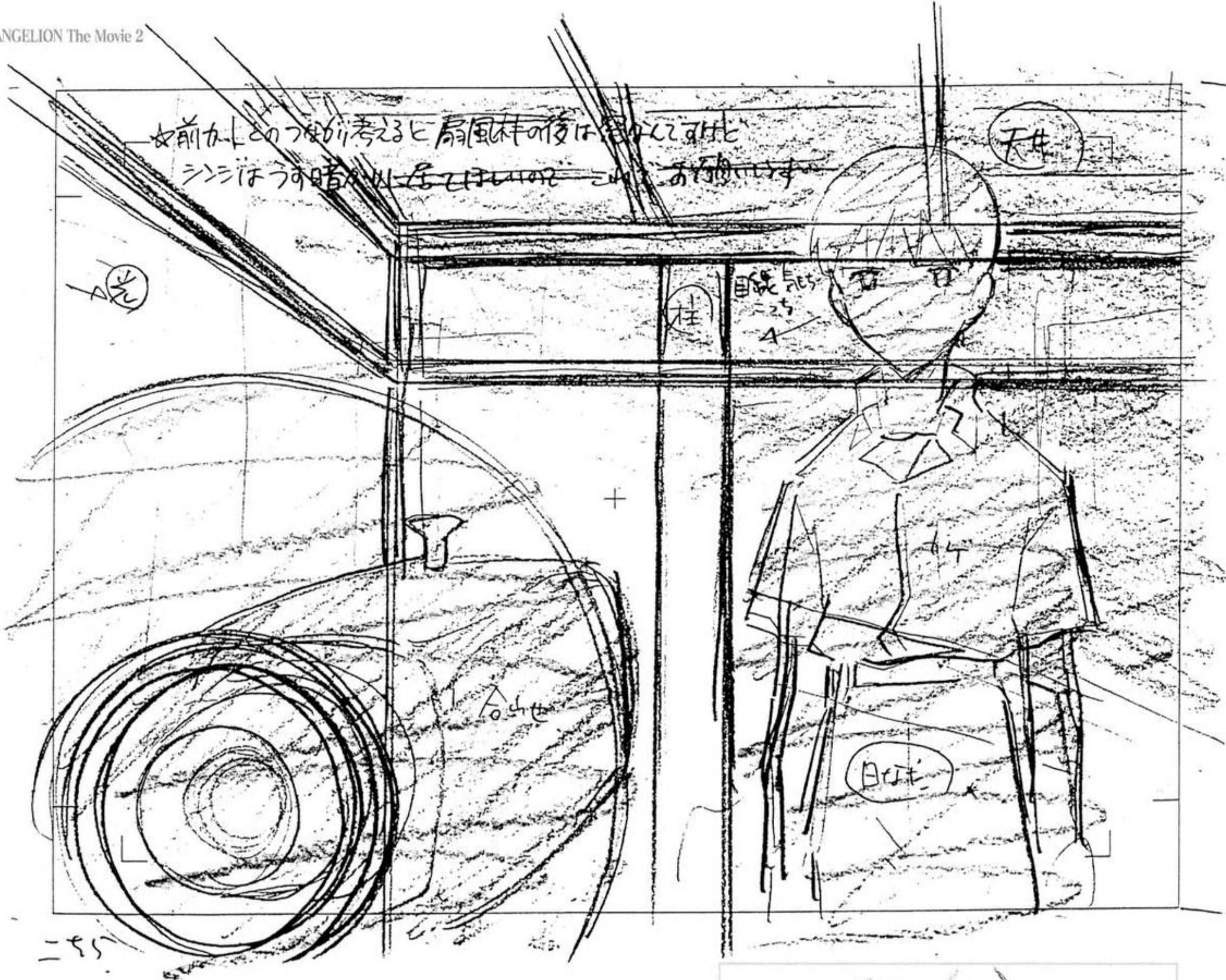

#26-C204レイアウト

#26-C204

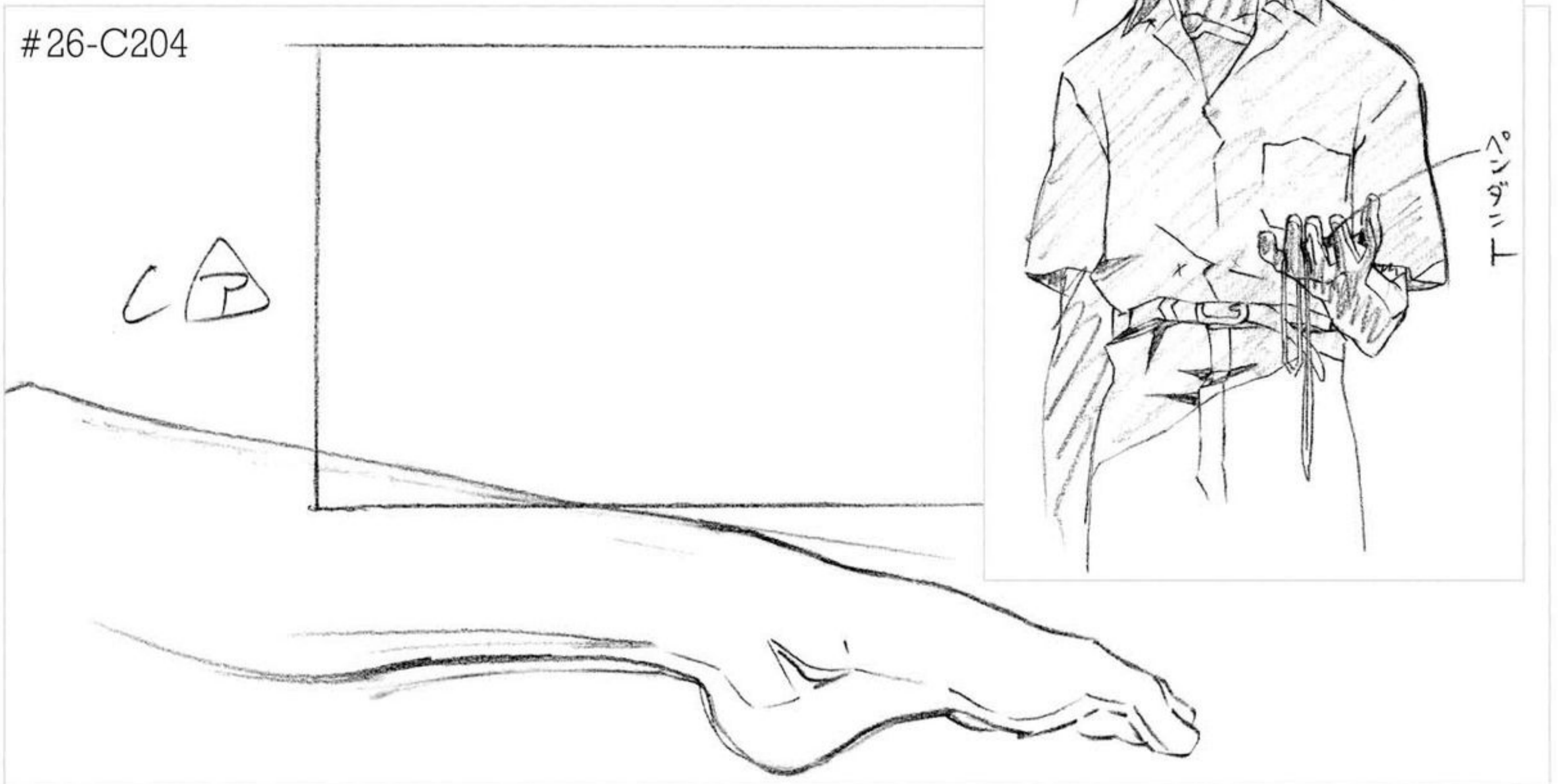

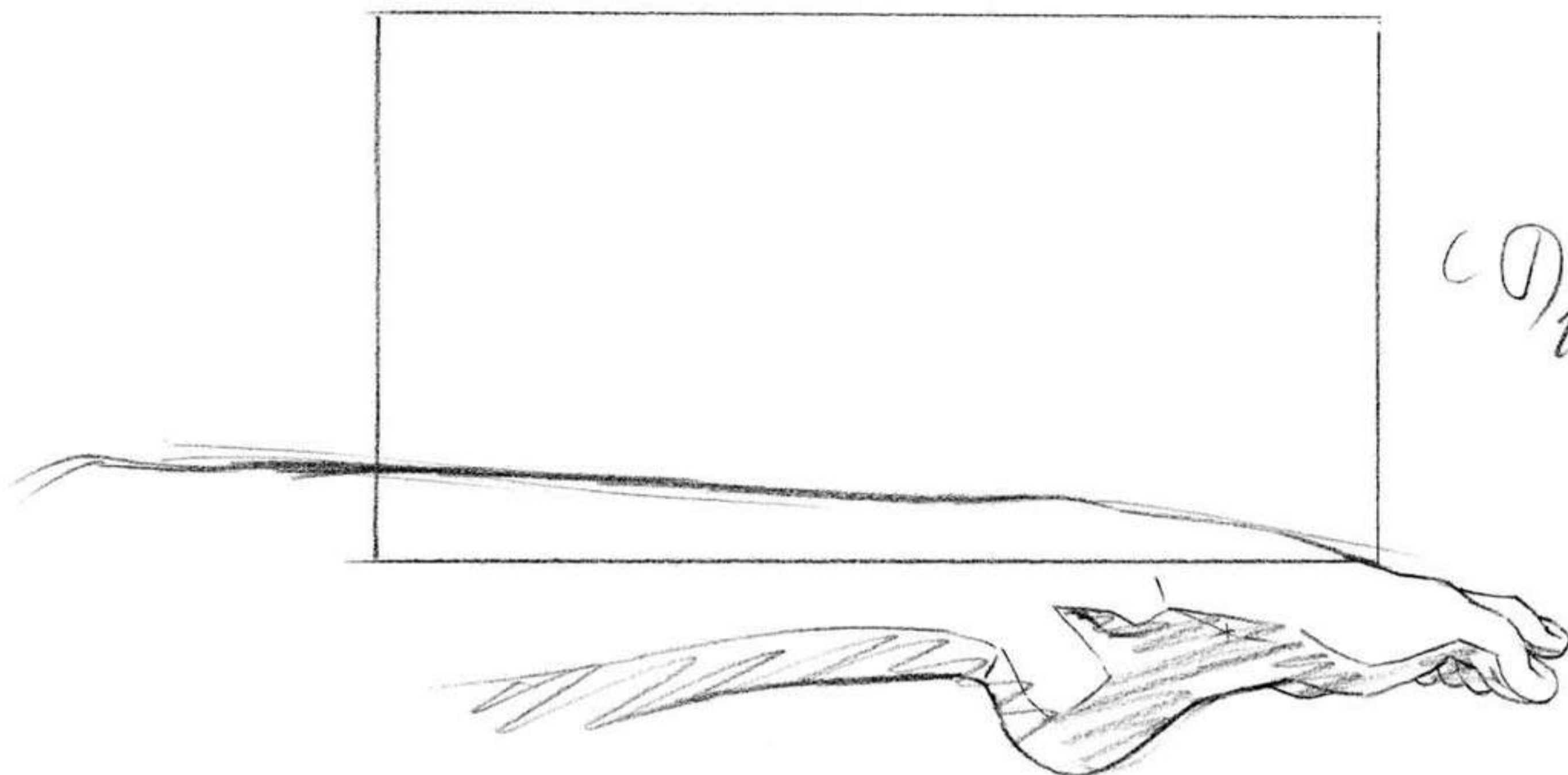

(1) 1/2

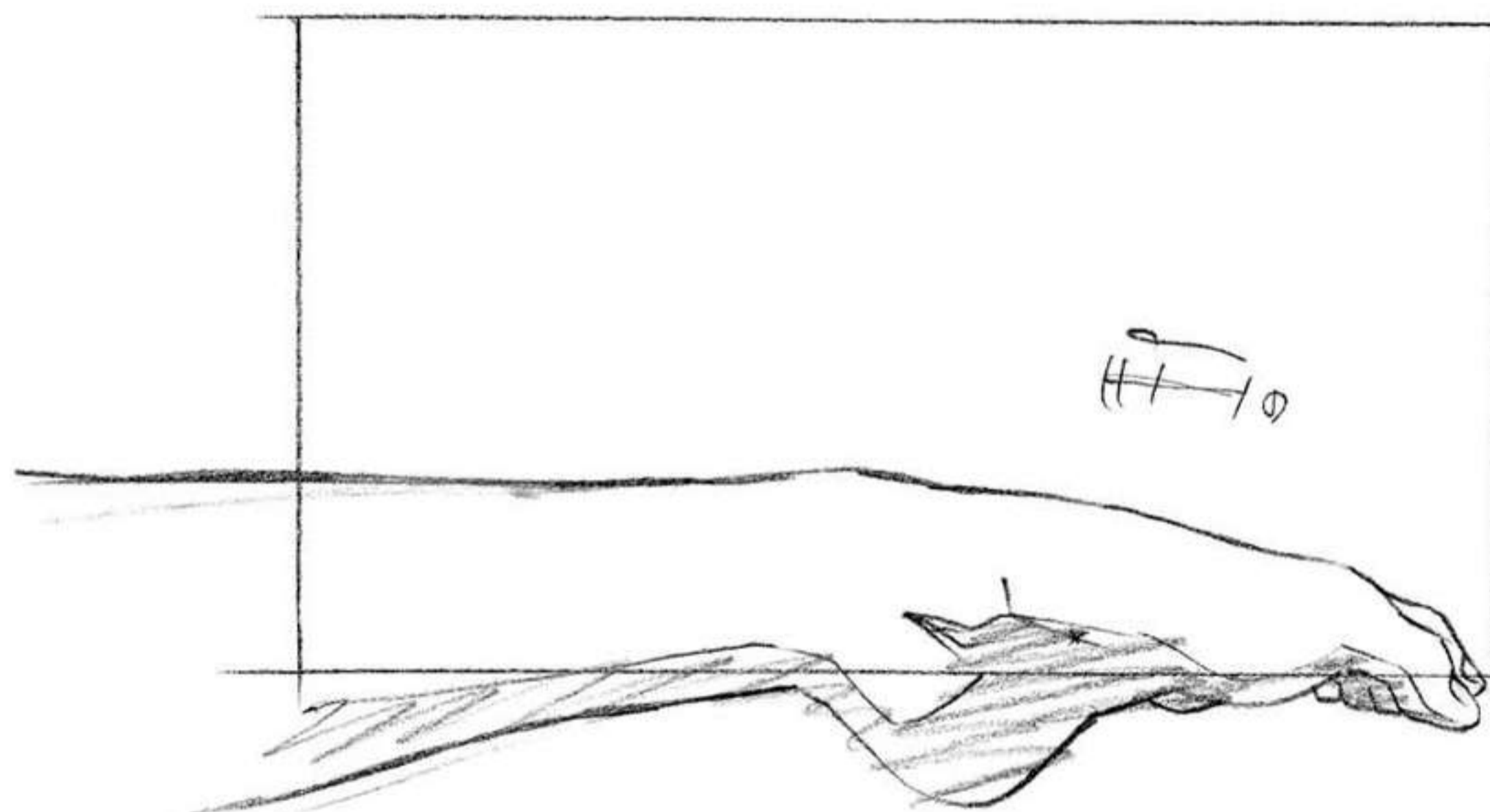

H+10

(2)

3

(2) H+10 (3)

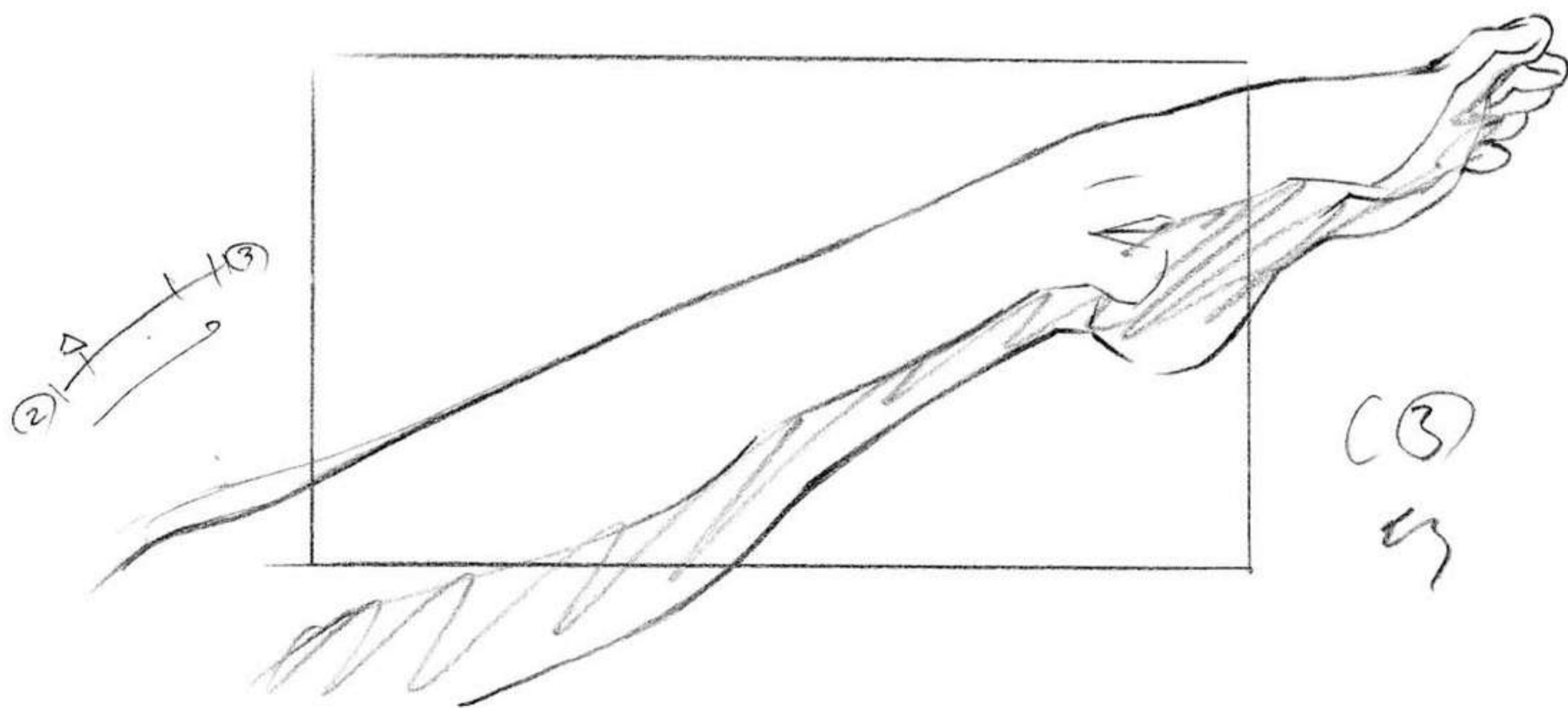

(2) H+10 (3)

(3)

3

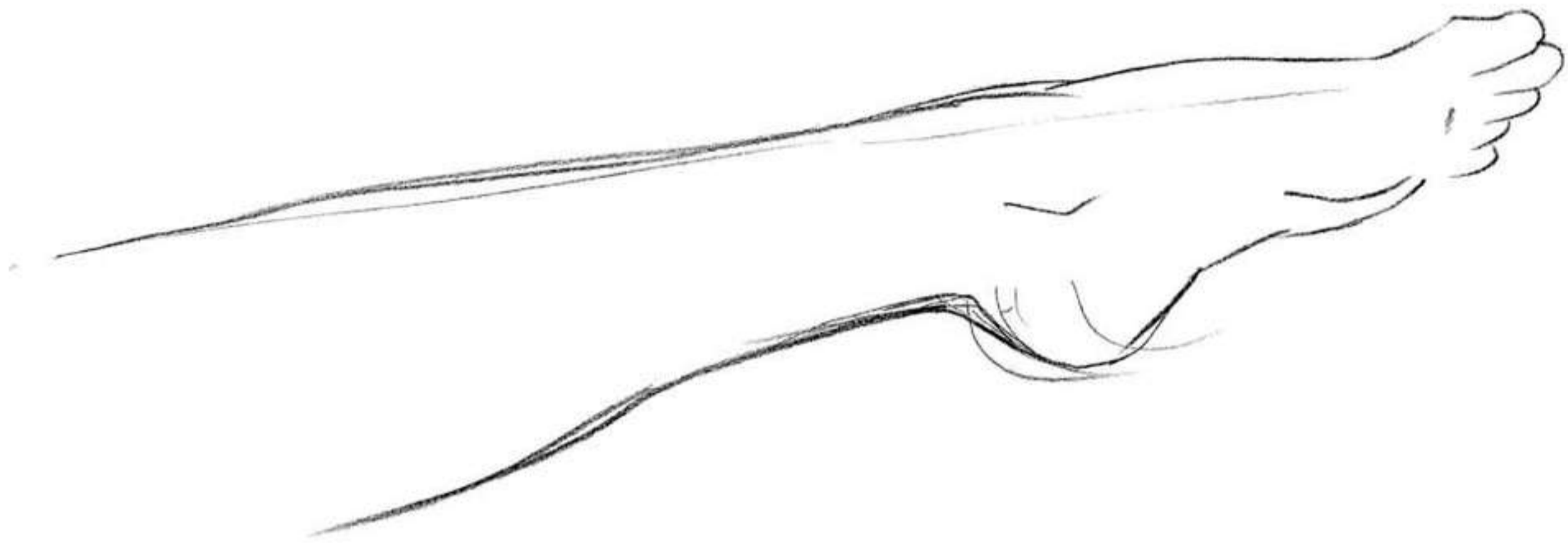
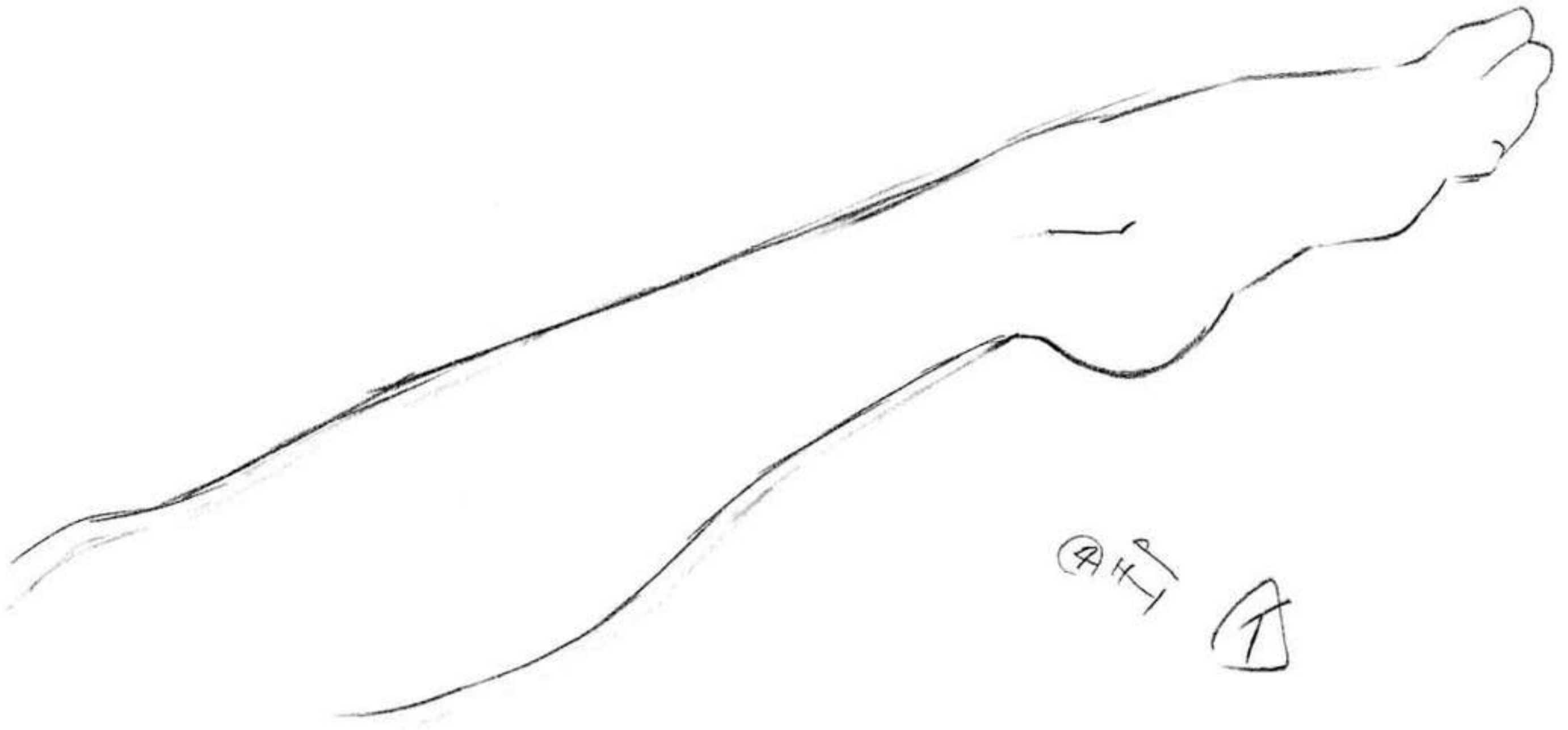

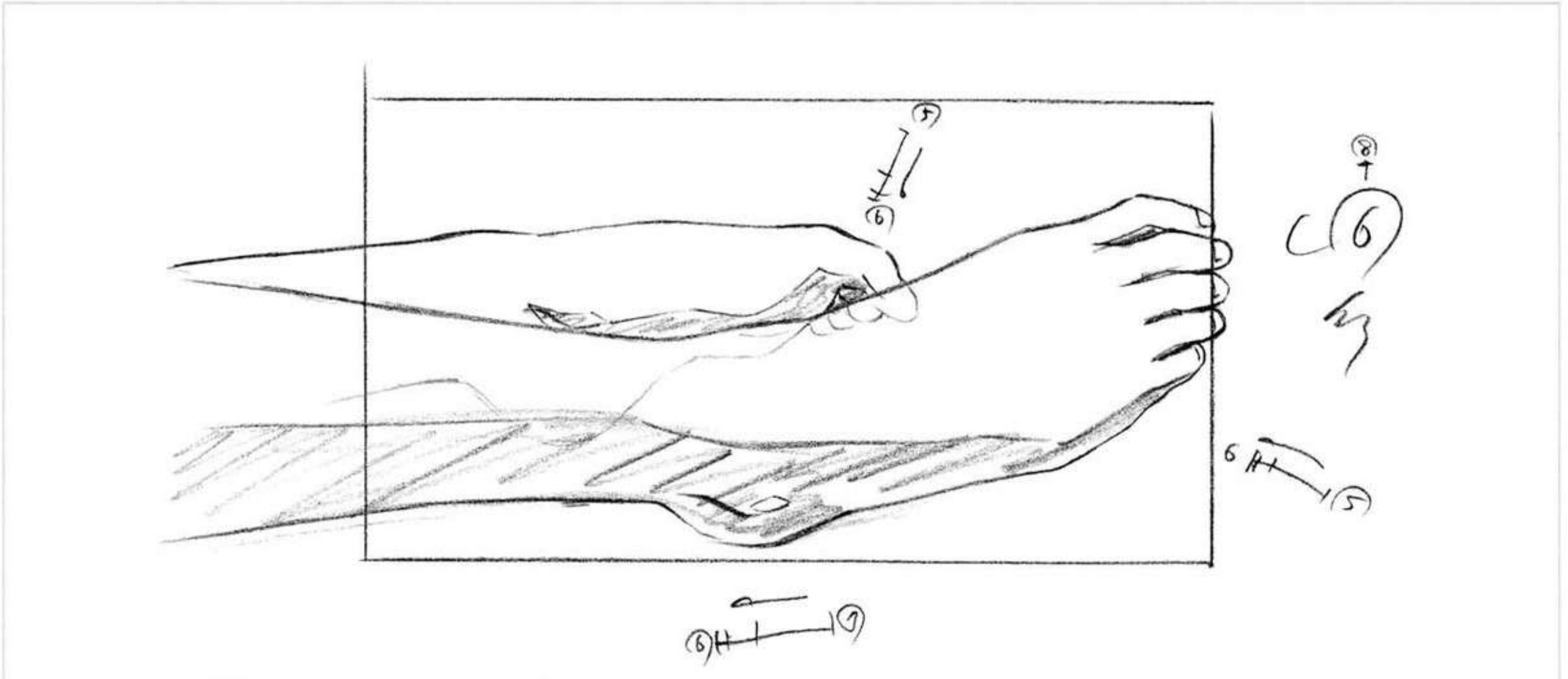
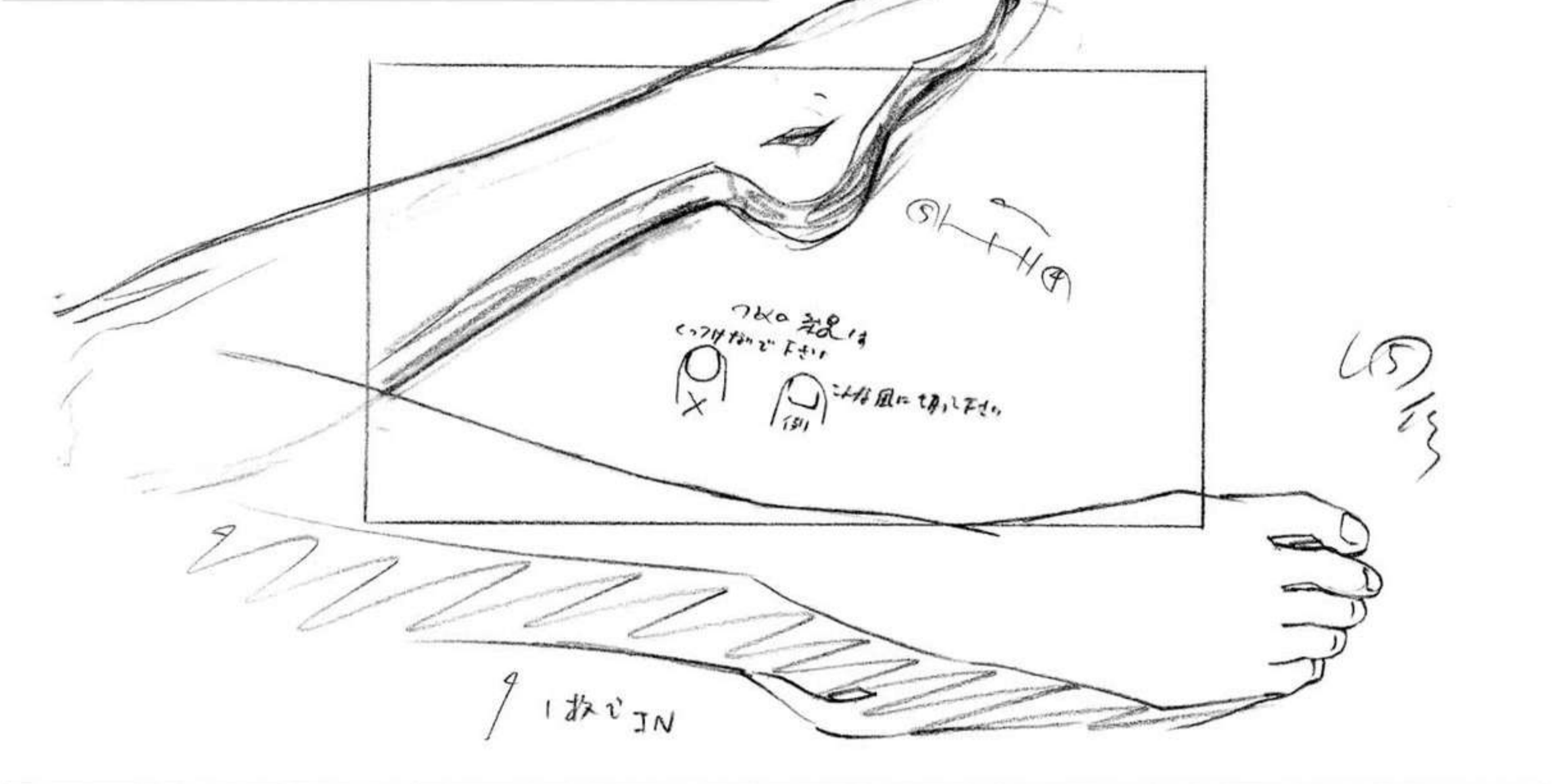
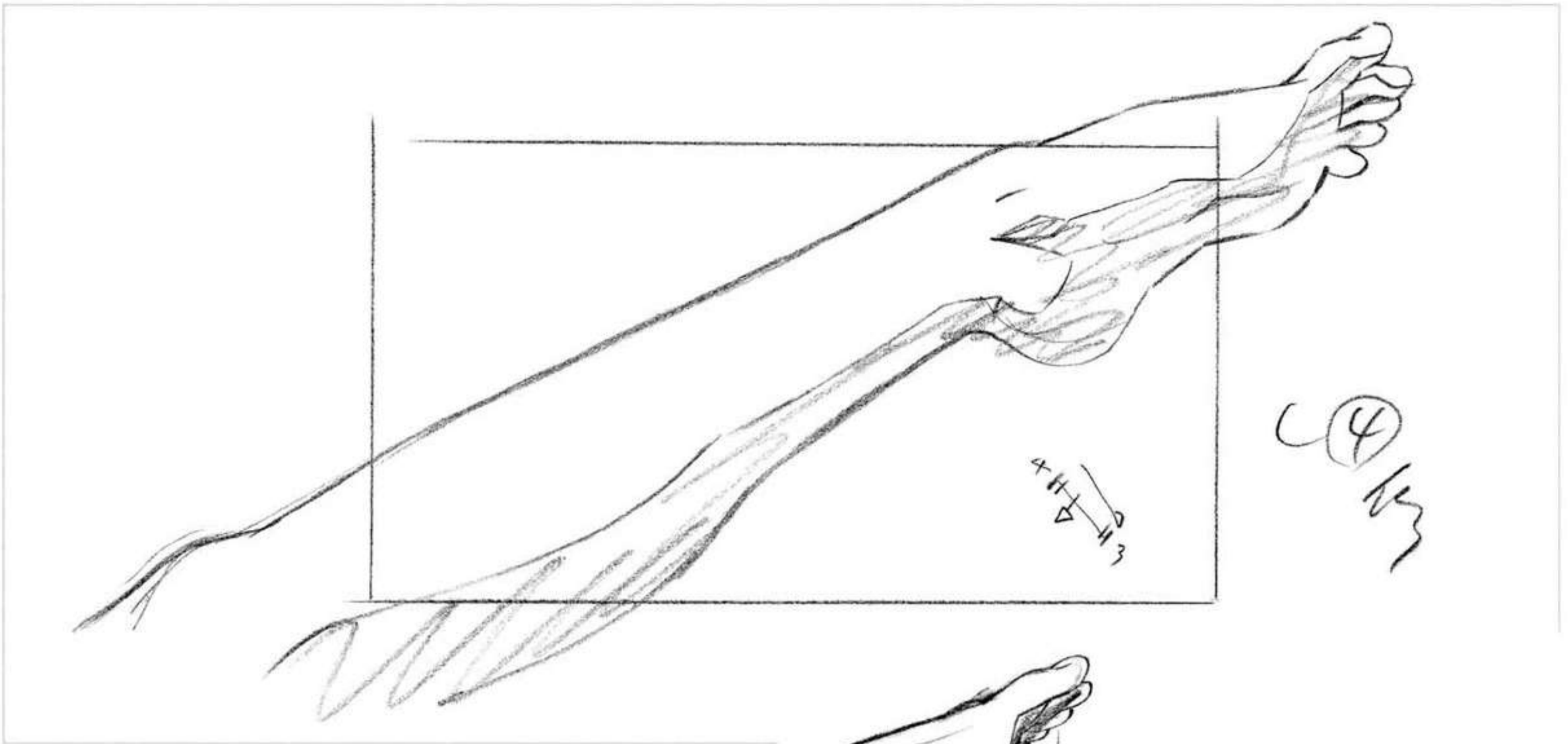

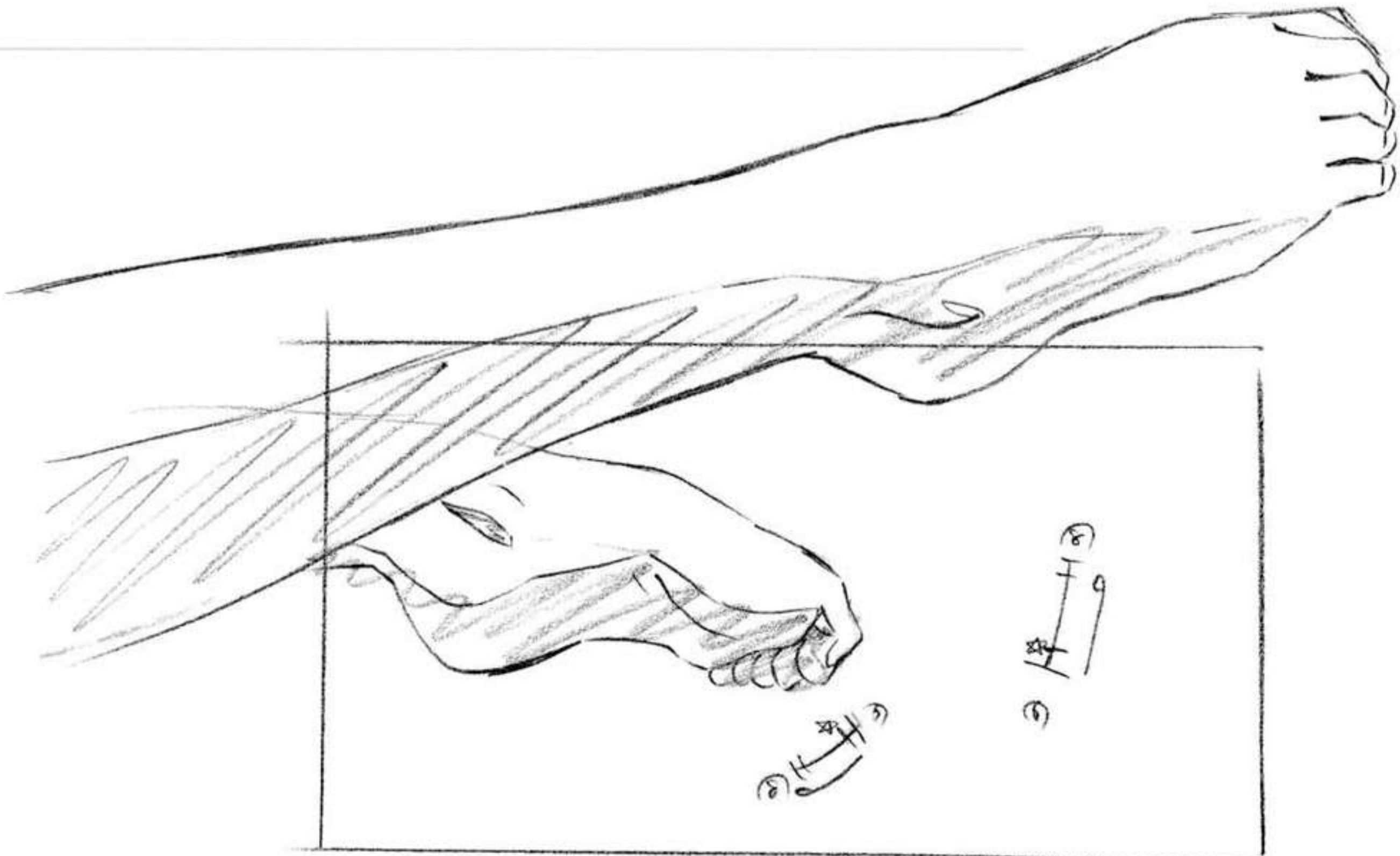
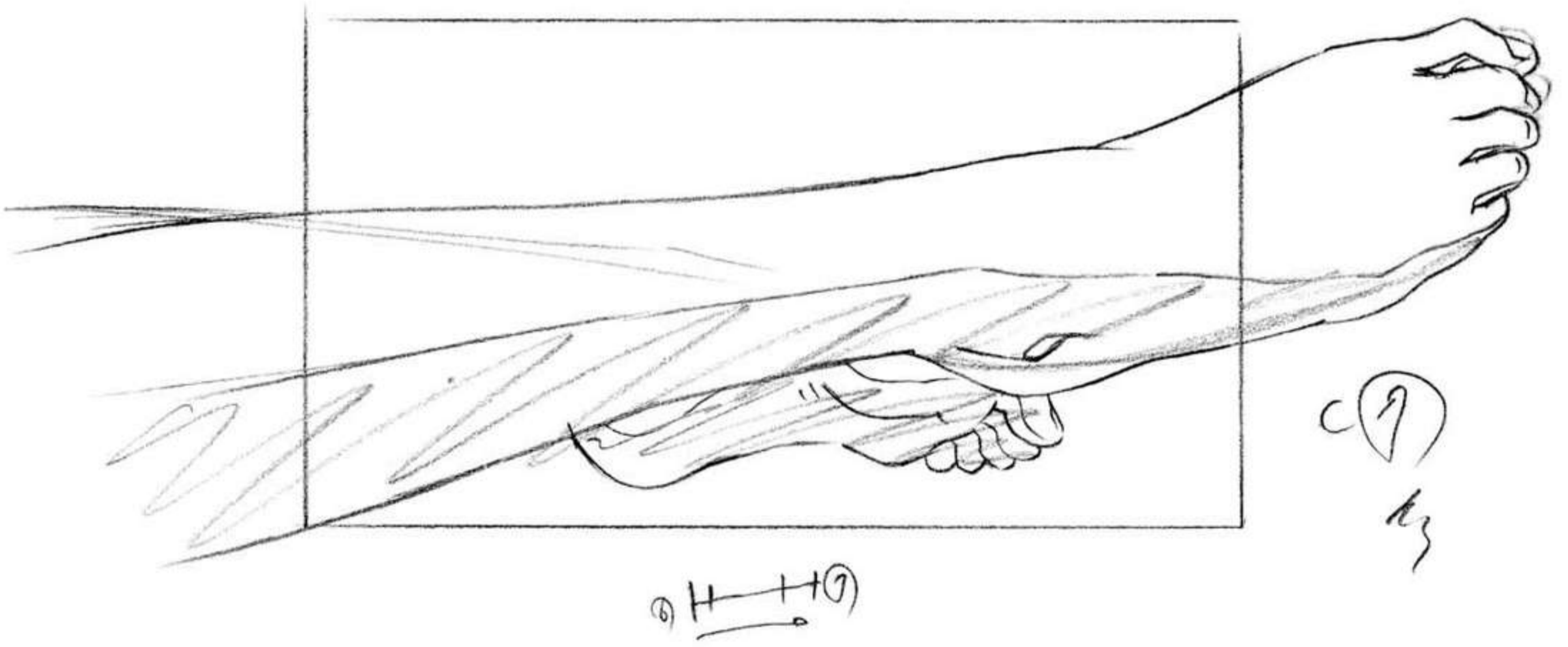

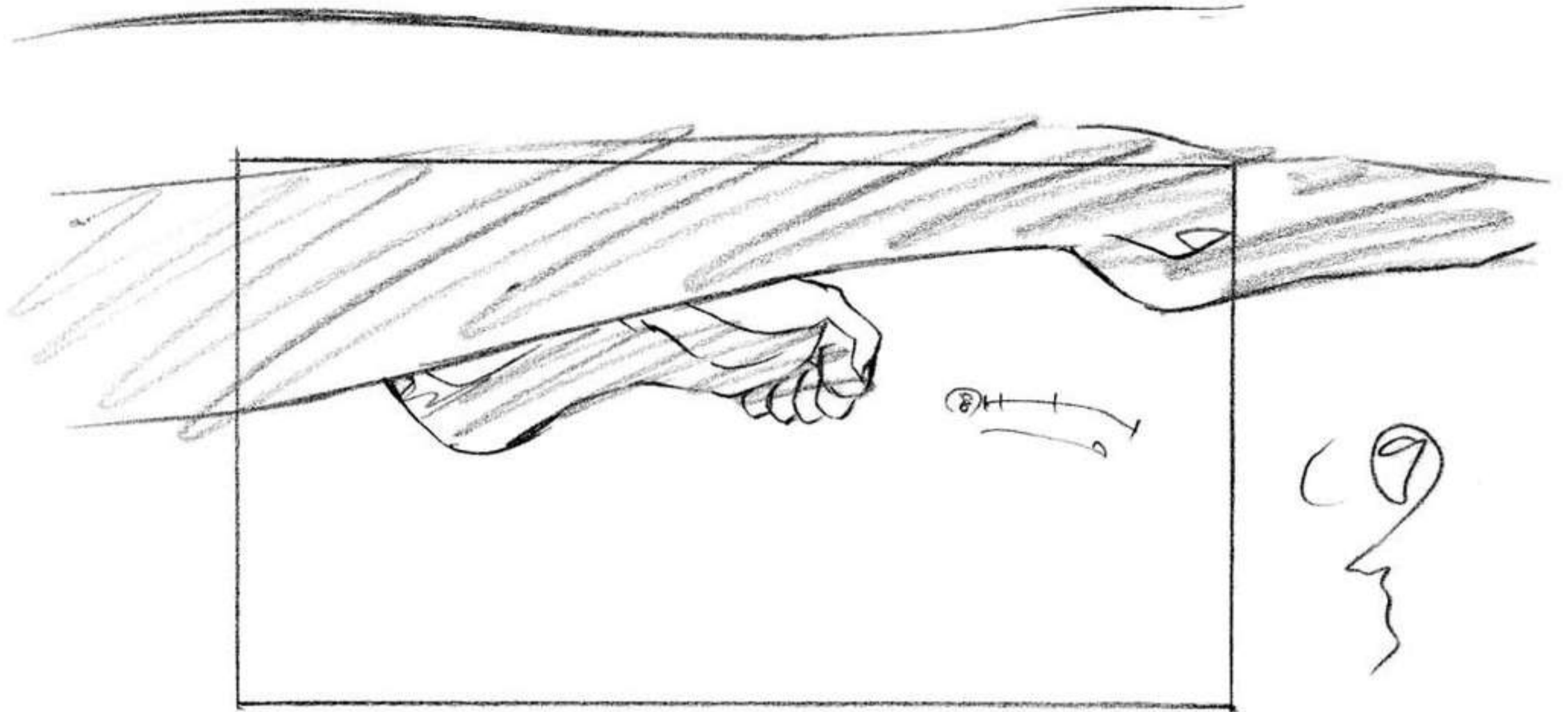

⑧

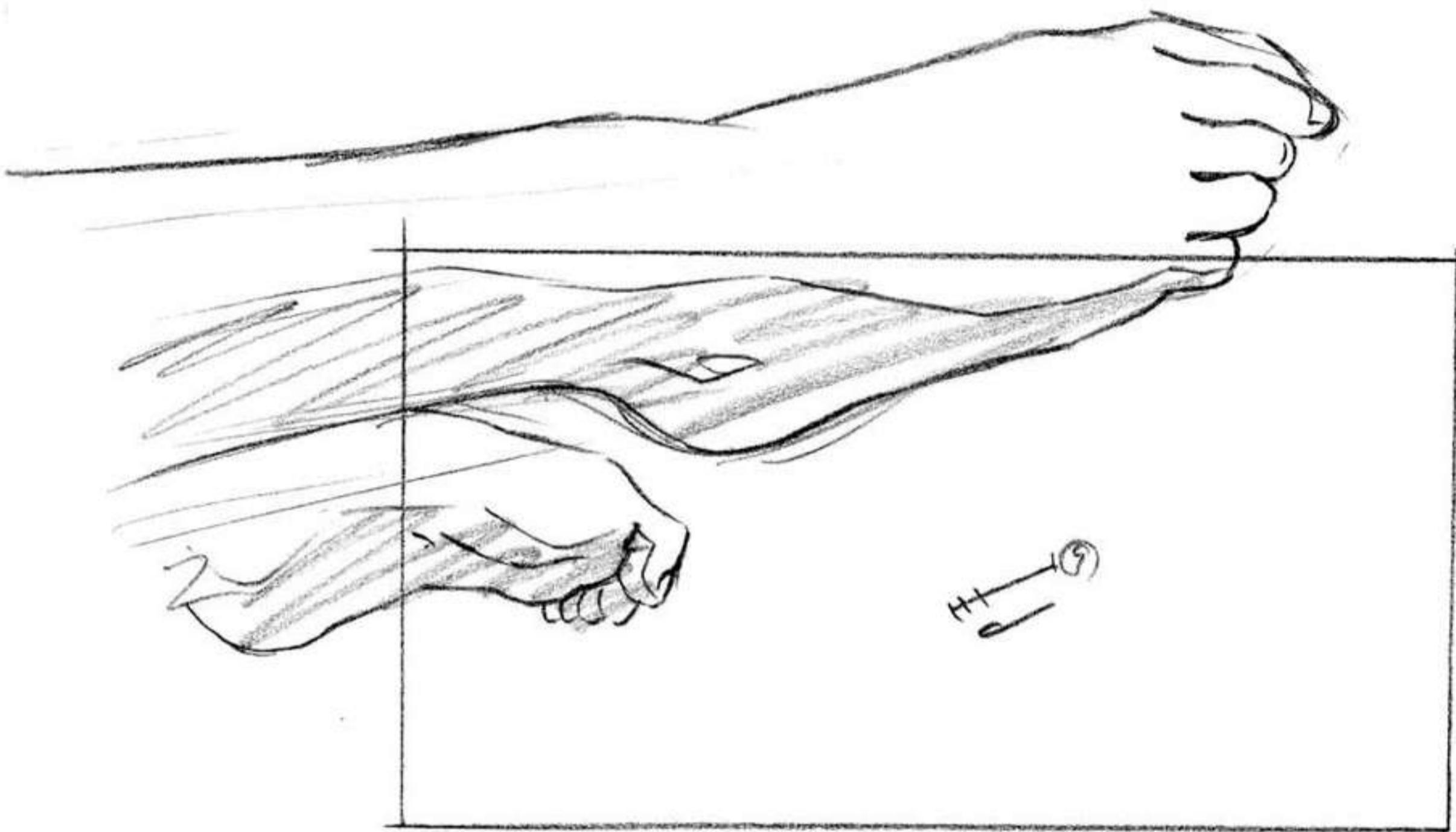

⑨

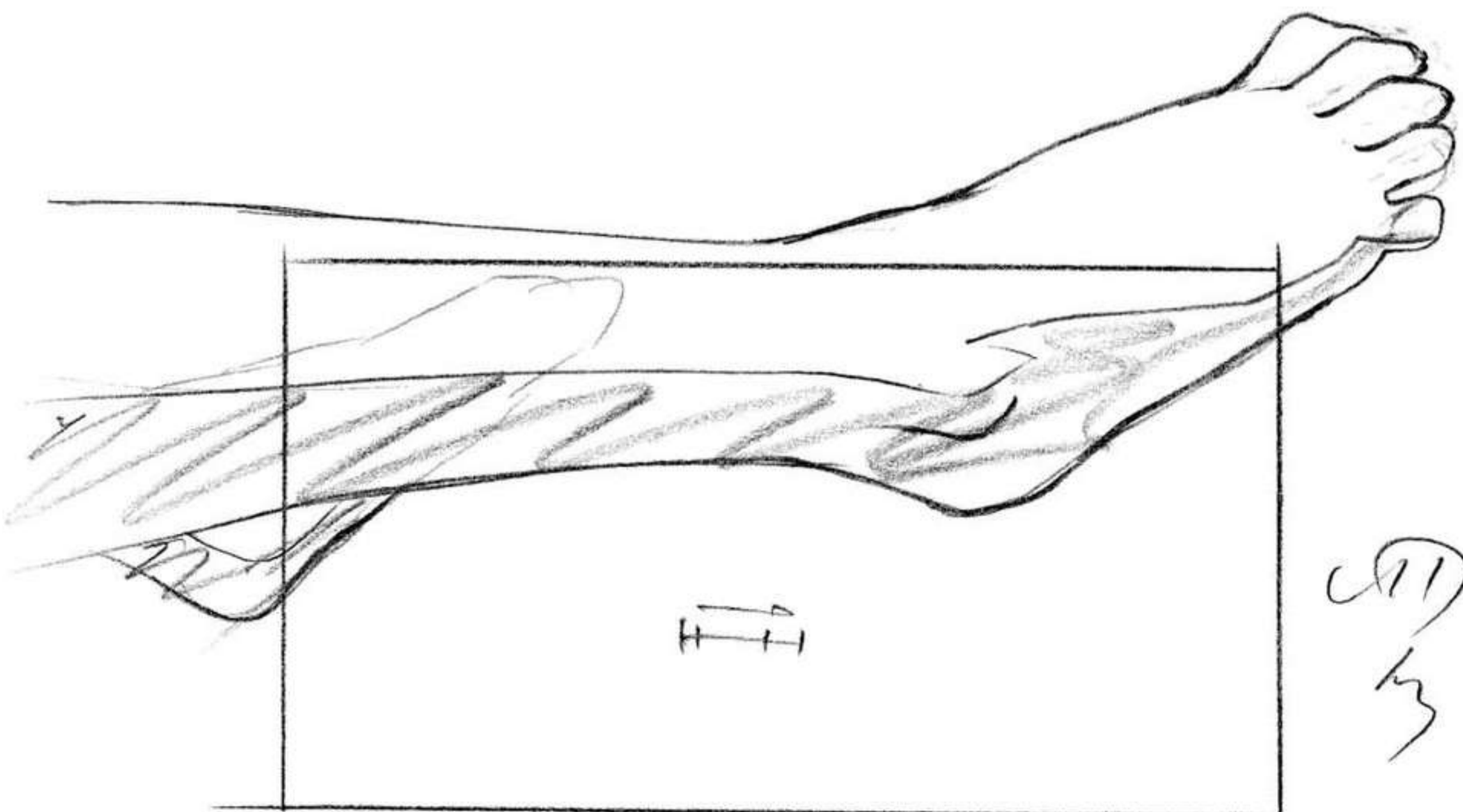

⑩



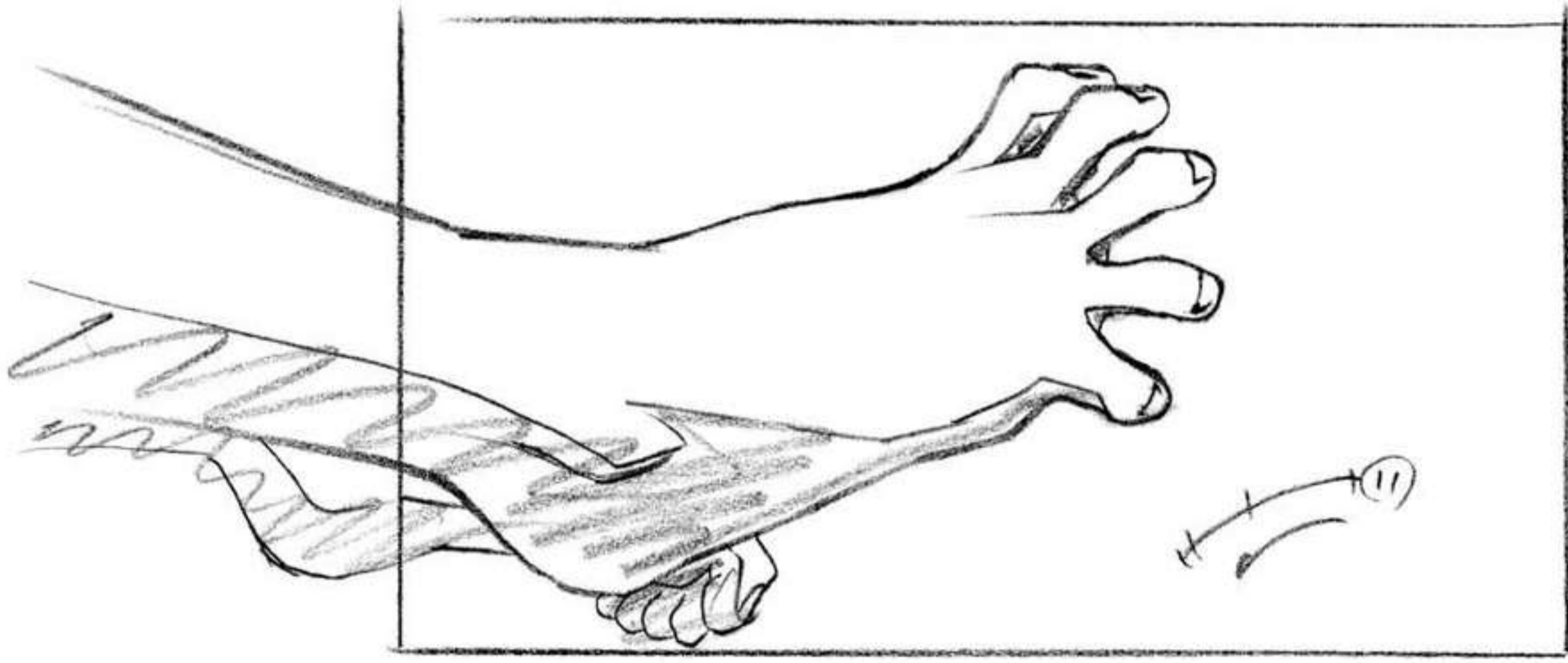

✓
①②

①②

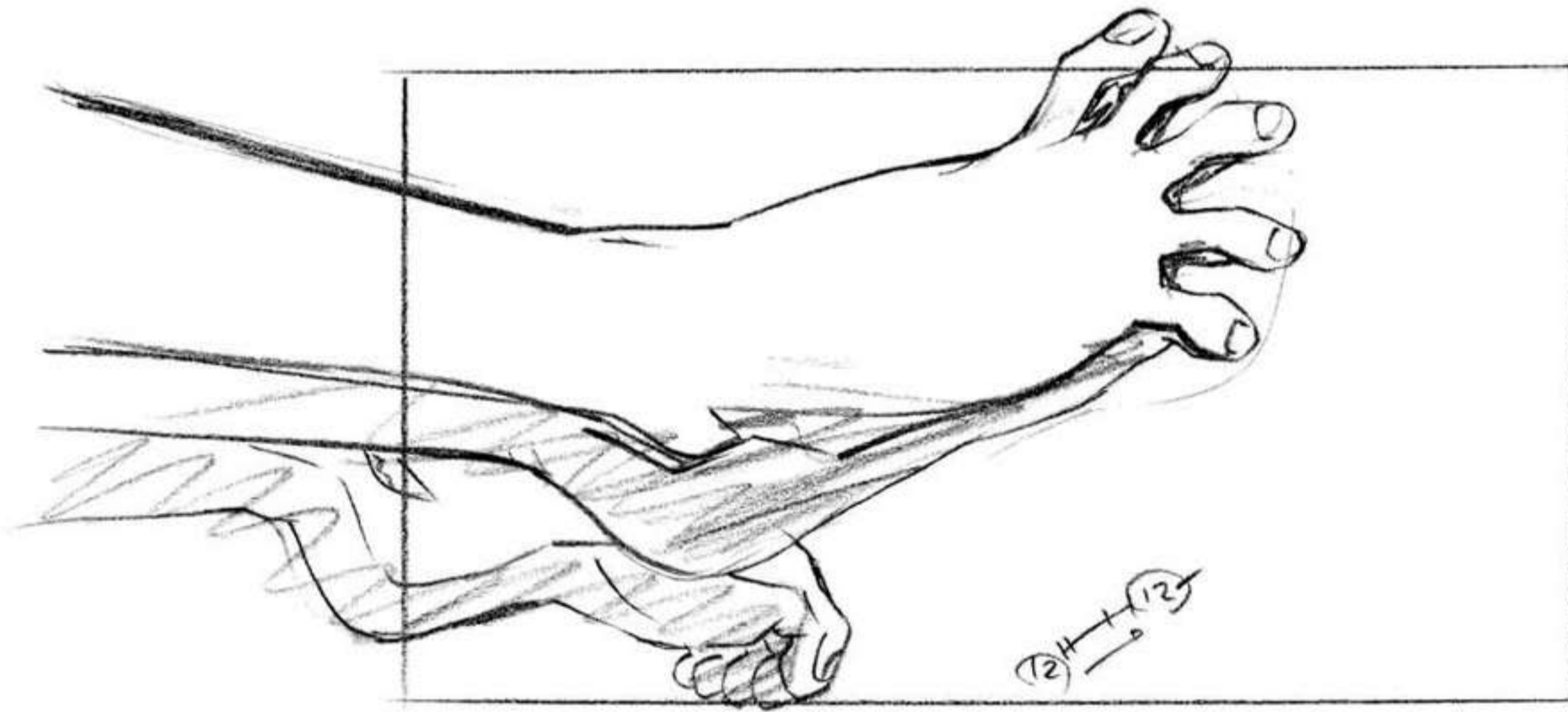

①②

①②



①③

①③

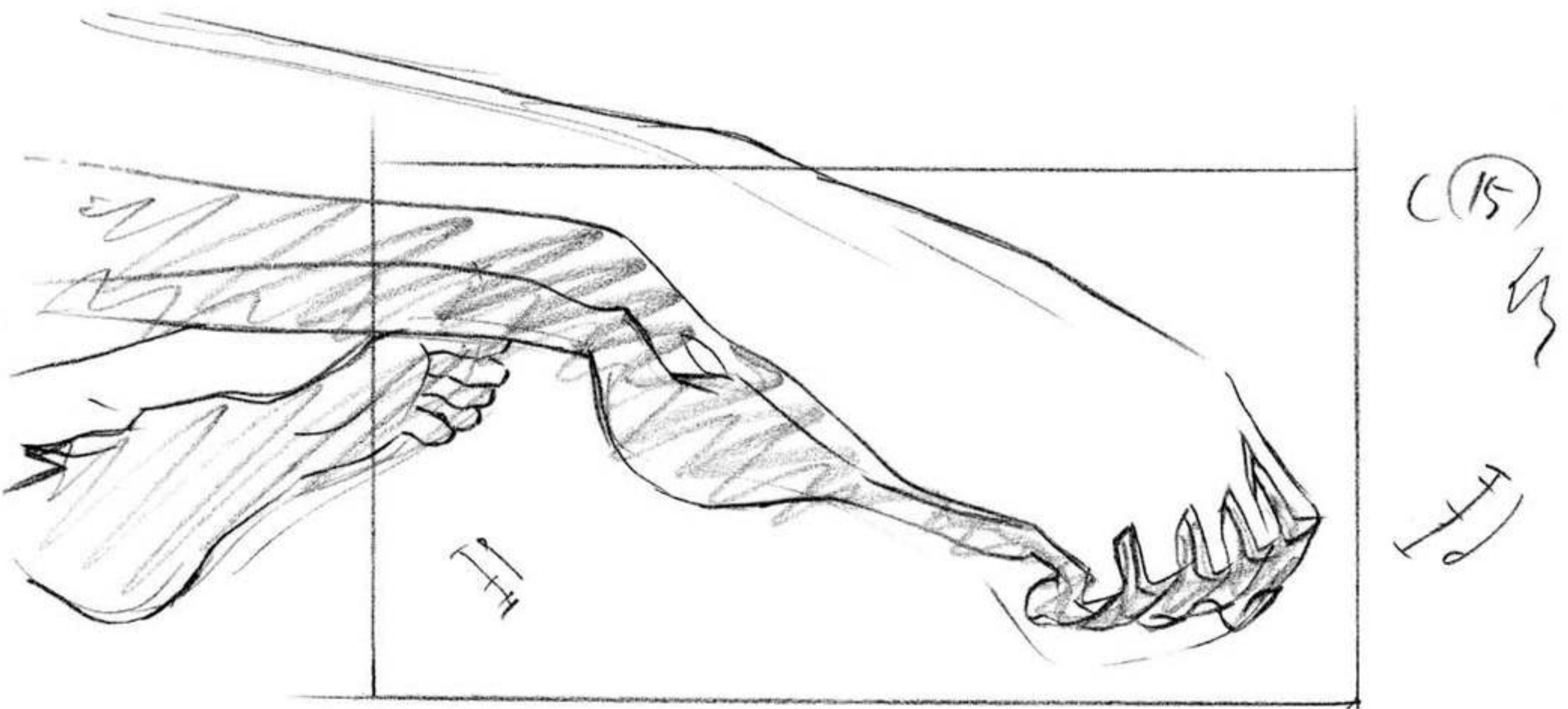
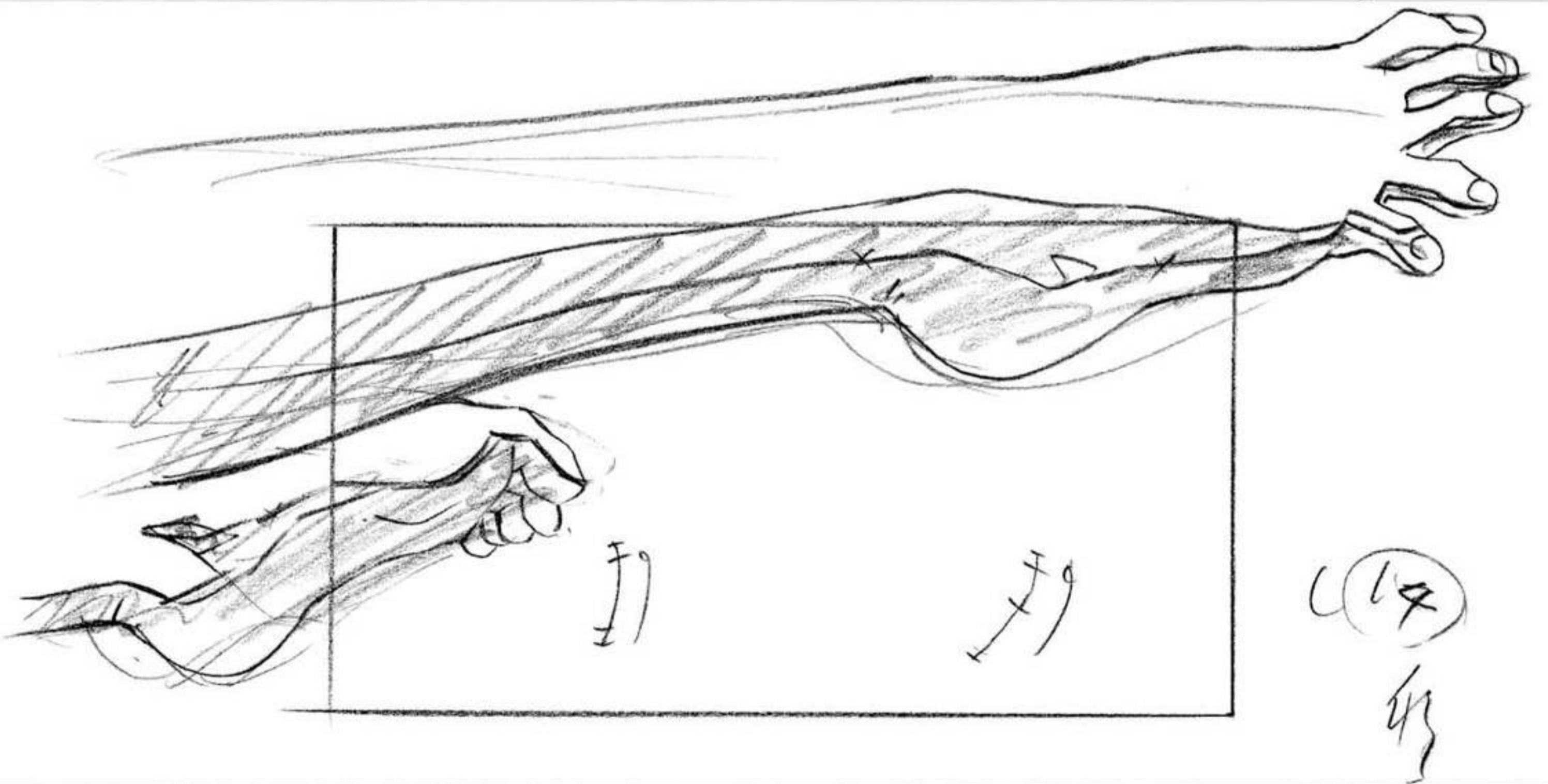
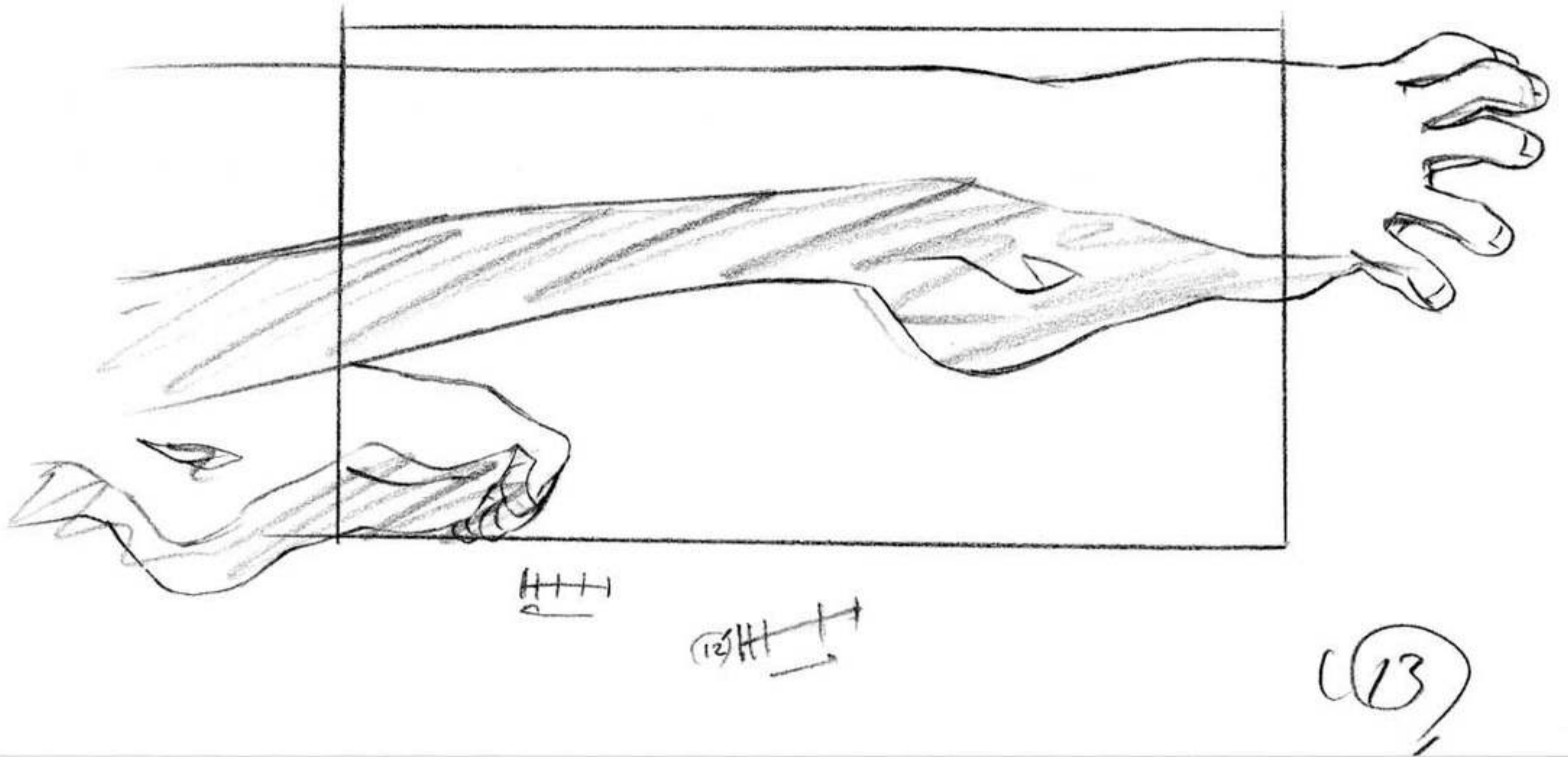

A	B	C	74
1			74
2			76
3			78
4			80
5			82
6			84
7			86
8			88
9			90
10			92
11			94
12			96
13			98
14			100
15			102
16			104
17			106
18			108
19			110
20			112
21			114
22			116
23			118
24			120
25			122
26			124
27			126
28			128
29			130
30			132
31			134
32			136
33			138
34			140
35			142
36			144

タイムシート

74	76	78
1		
2		
3		
4		
5		
6		
7		
8		
9		
10		
11		
12		
13		
14		
15		
16		
17		
18		
19		
20		
21		
22		
23		
24		
25		
26		
27		
28		
29		
30		
31		
32		
33		
34		
35		
36		

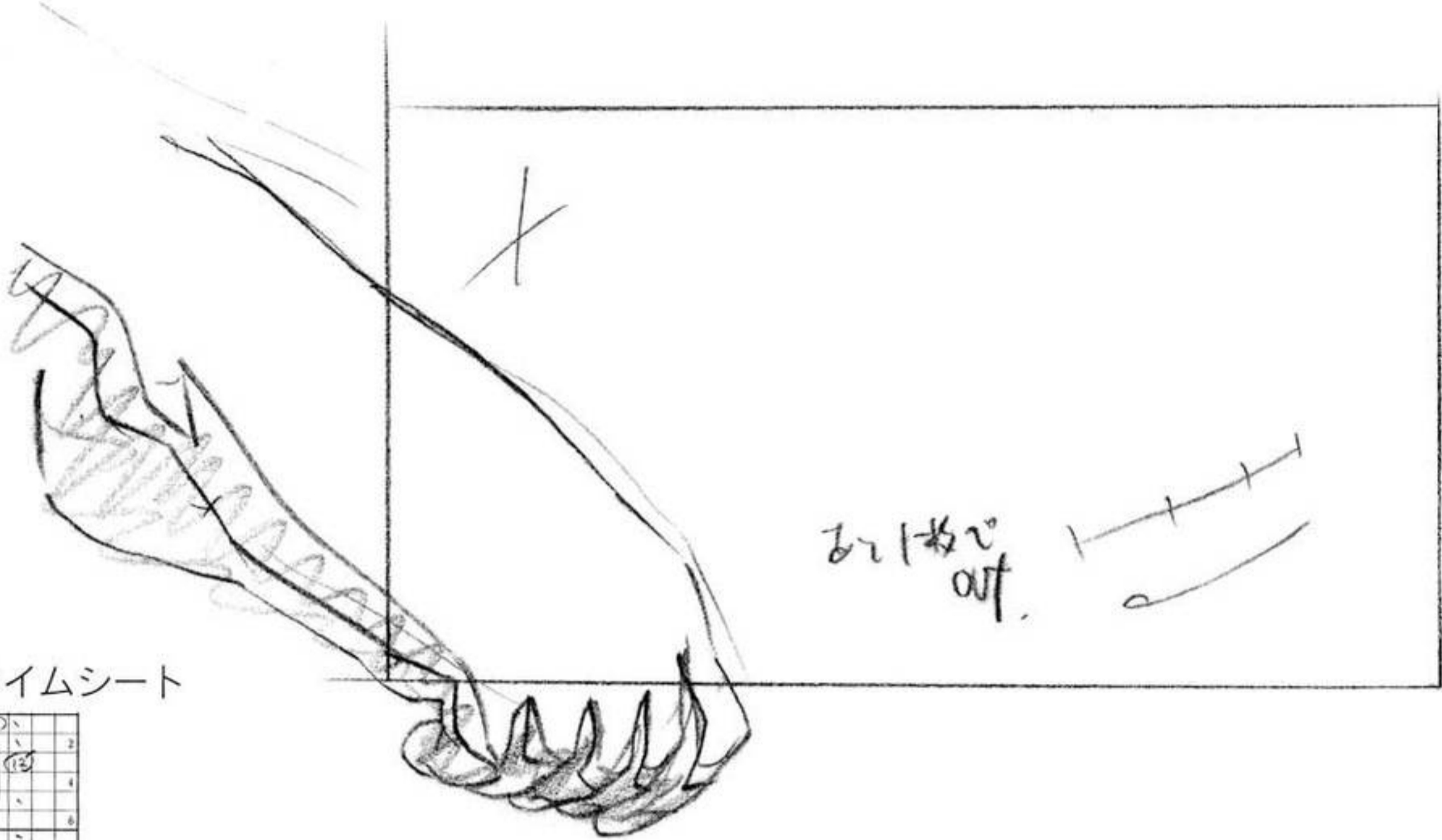

C16

おれが out

#26-C204レイアウト時作監チェック



基本的には

上かまど
外へ
内へ
下へ

中心さ
この動き、を撞かす感じ

このあたり
アメリ

- ① ↓
- ② ↓
- ③ ↓
- ④ ↓
- ⑤ ↓
- etc

R:長崎

レポートを
こころ
こころ
おせり
とか

大変おかし
生々しく
おもしろくです

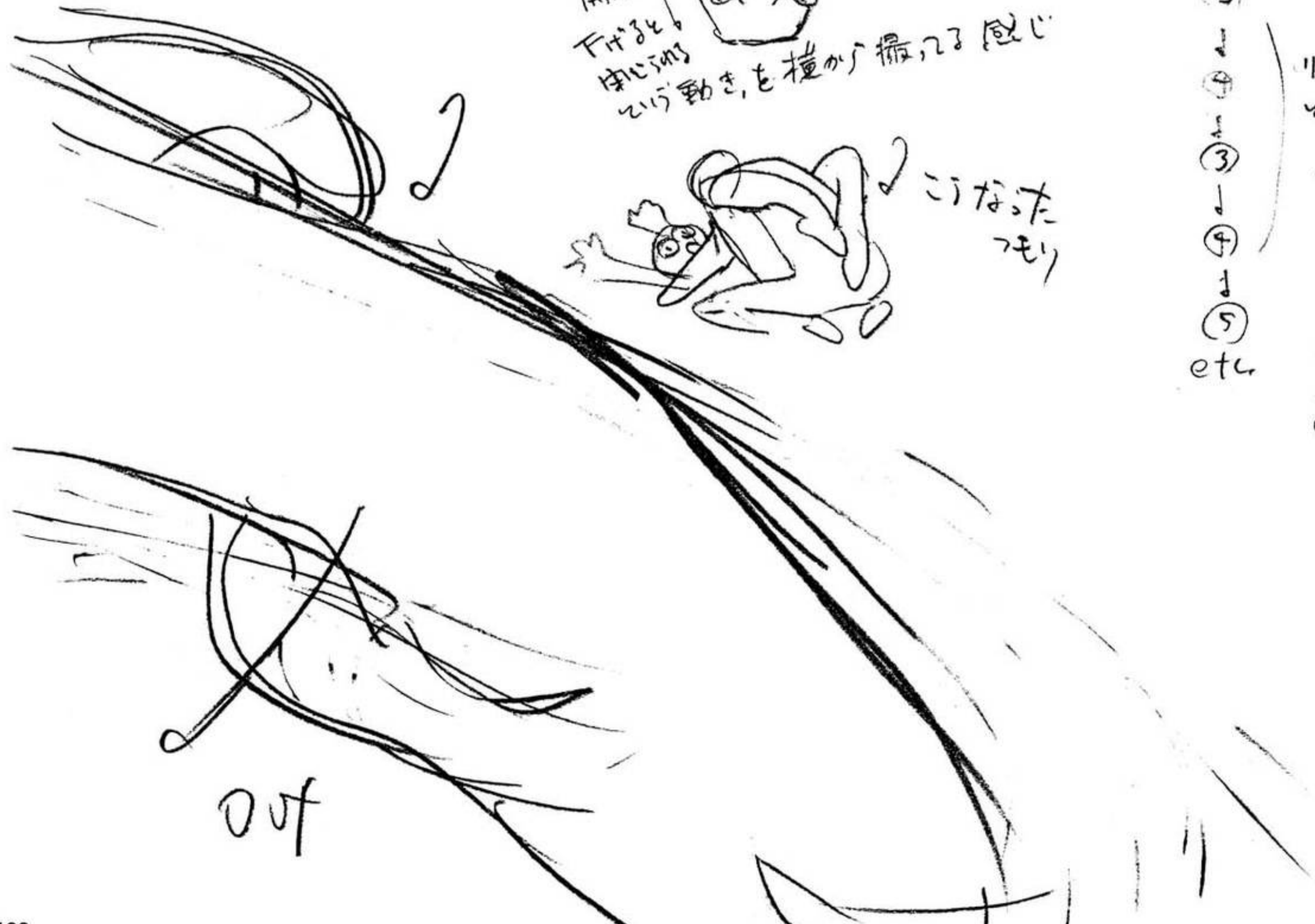

out

C15

#26-C213



クニナシ

全部描いて下さい。



A2

クニナシ



A3



A4



A5

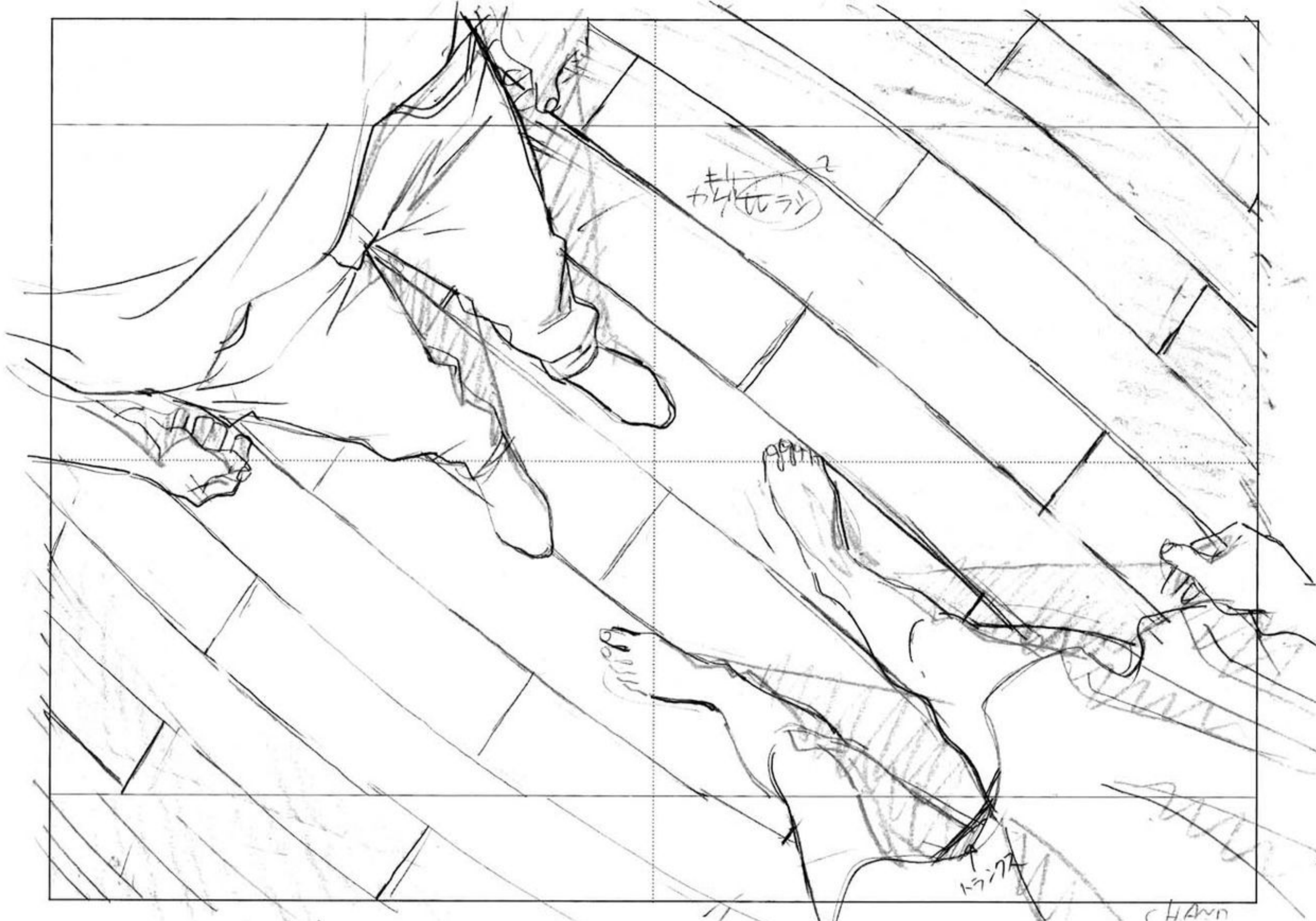

#26-C215レイアウト

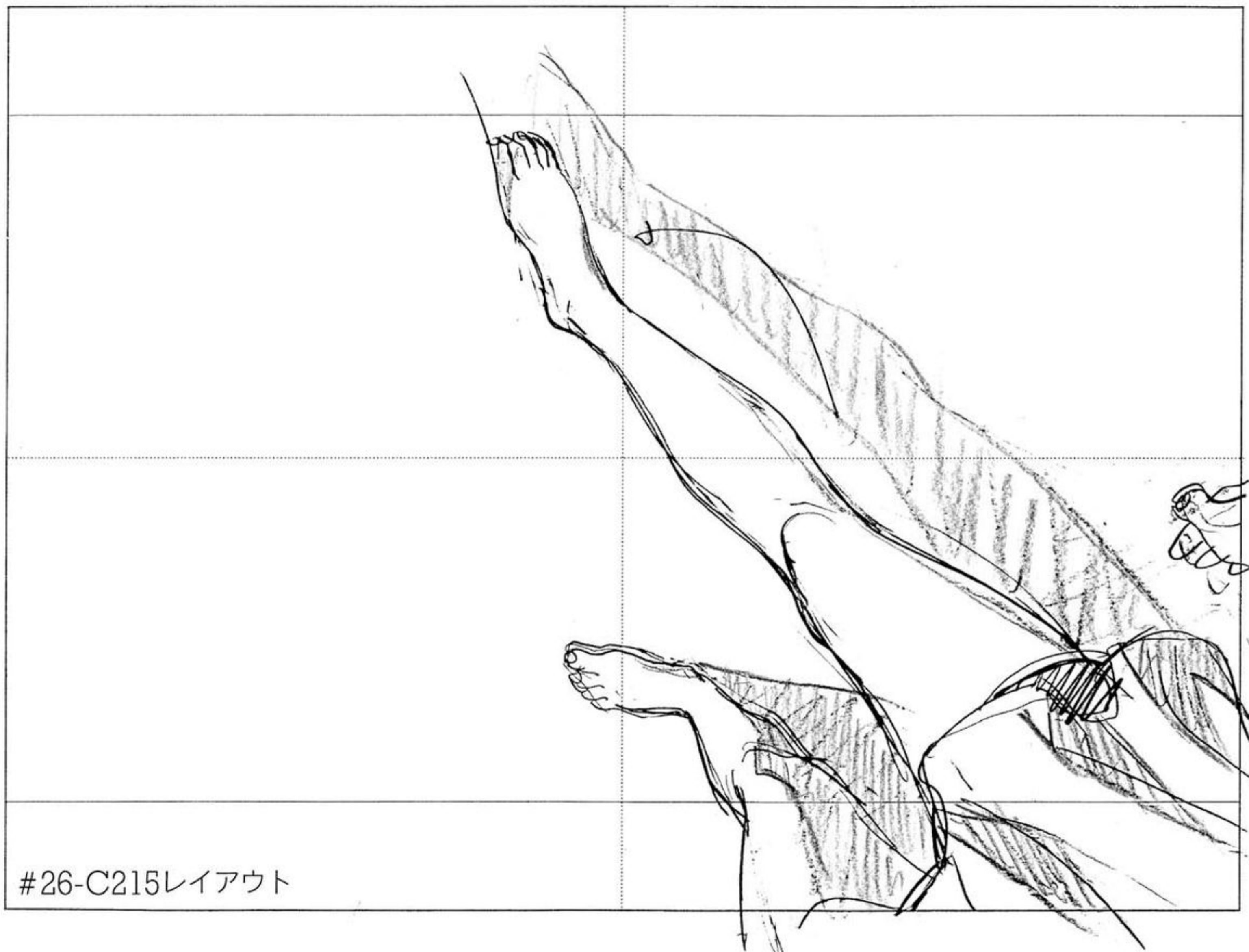

#26-C215レイアウト

11セリ入0時の
#7



#26-C216.218

AD #3



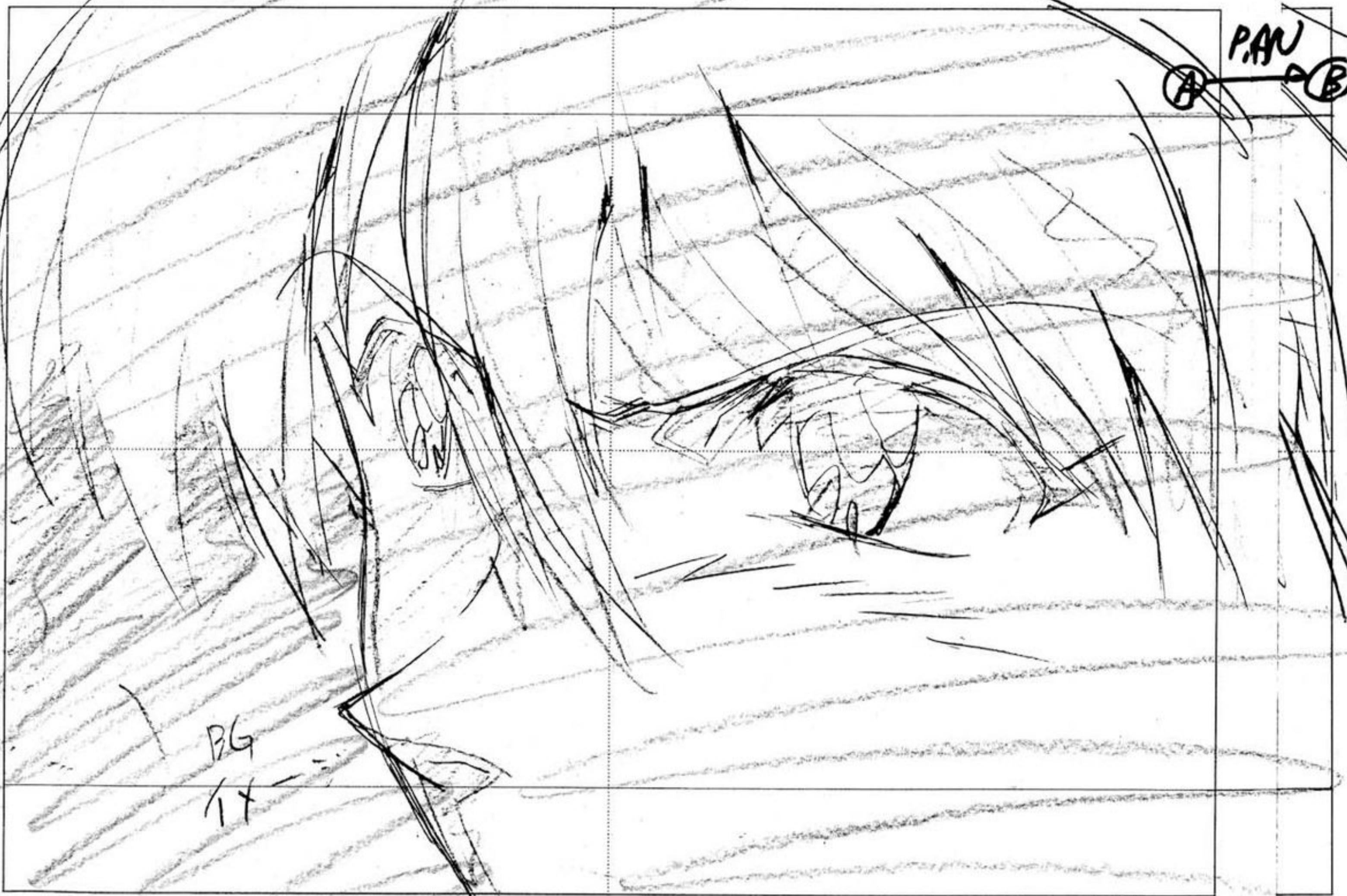

#26-C215レイアウト



修正原画

全セリ

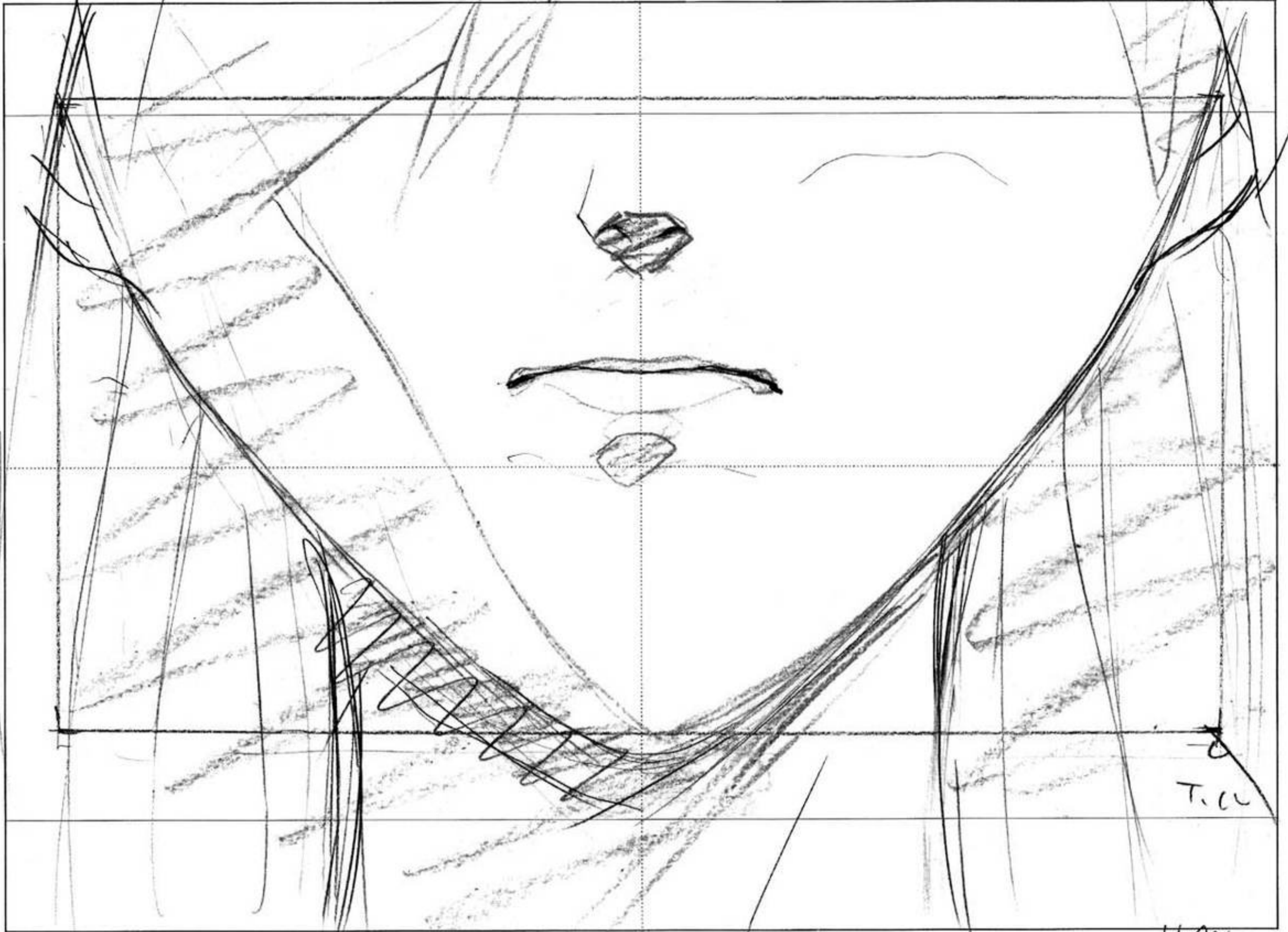

T.11

H.A.YO

大んたキースよ♡

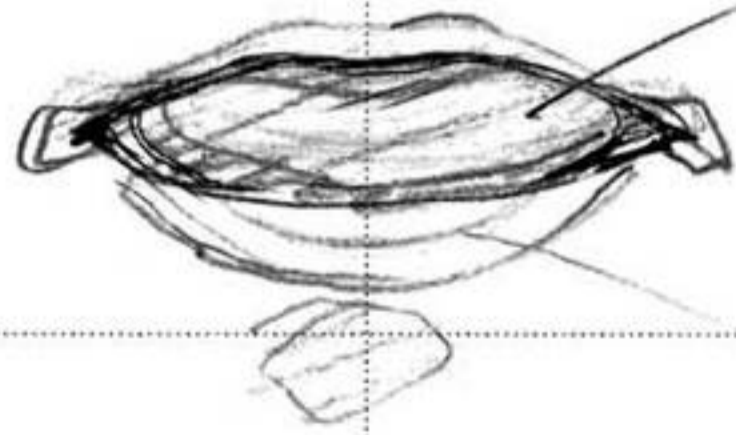

舌の動きは
なまめかきさかたせる
とかもしろいかな...

うすく口びる色さ入れる?

このあたり演出と要相談
下記下し。
CHAYU

軸画にも必ず
書きおいて
下さい。

くちびる色 (紅に近づけず。27)

くちびるの分けは
ごく薄く



首、髻 A① 後 B① 口元 C①

#26-C223

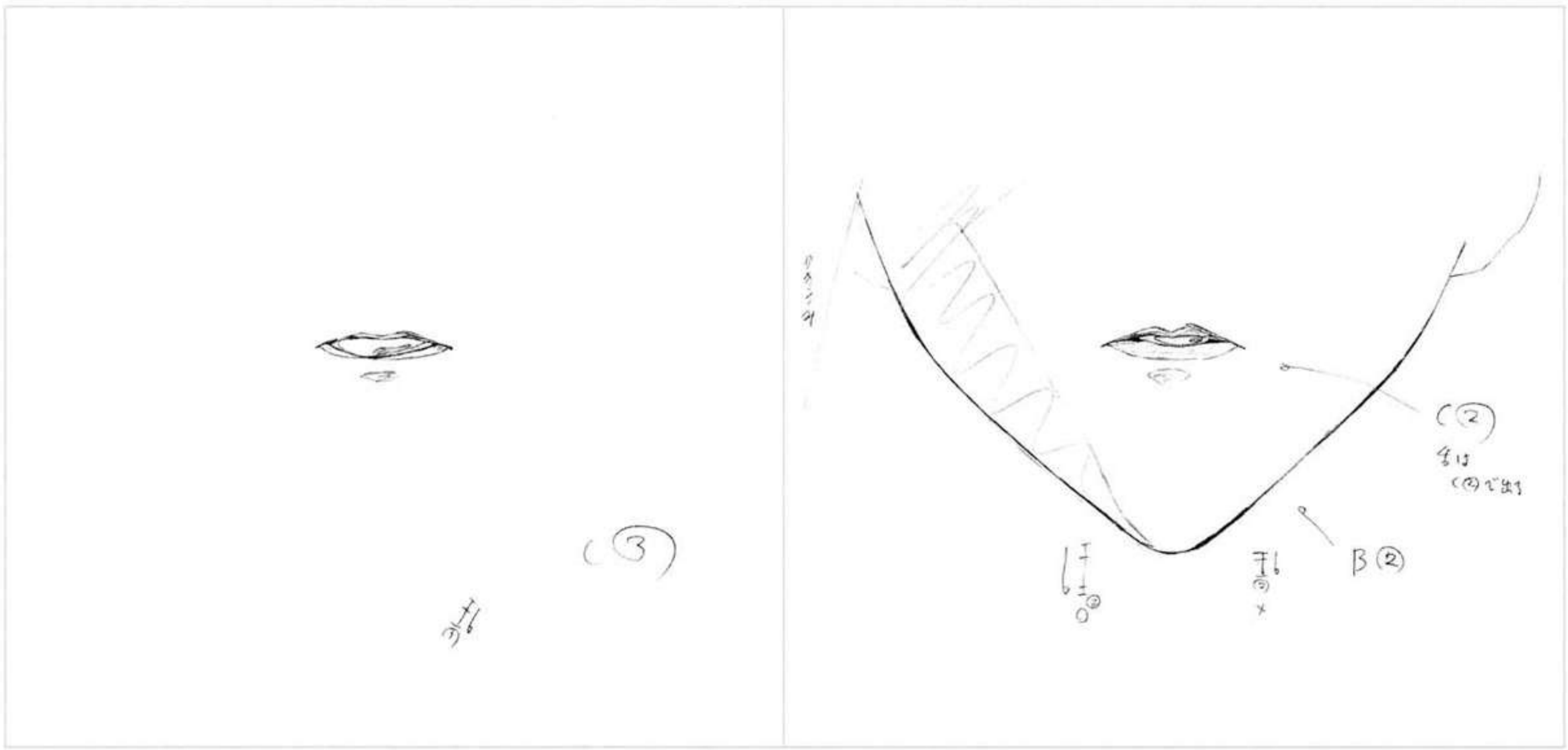



II

(8)



III

(5)

④

Handwritten notes in Japanese, including the word "リップ" (lip) and other characters.



II

(9)



II

(6)



III

(10)



III

(7)

全セル

#26-C224レイアウト

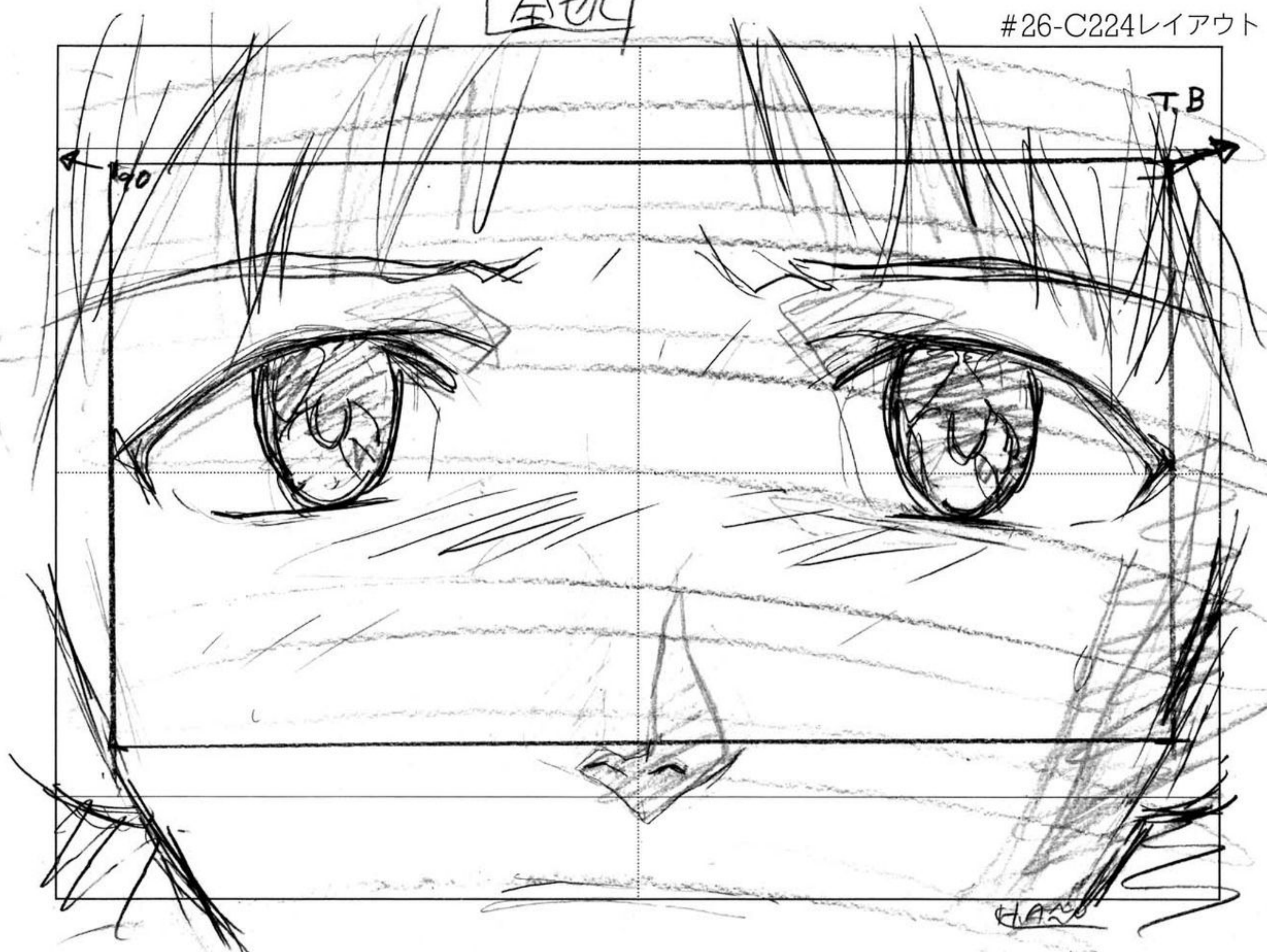

#26-C224

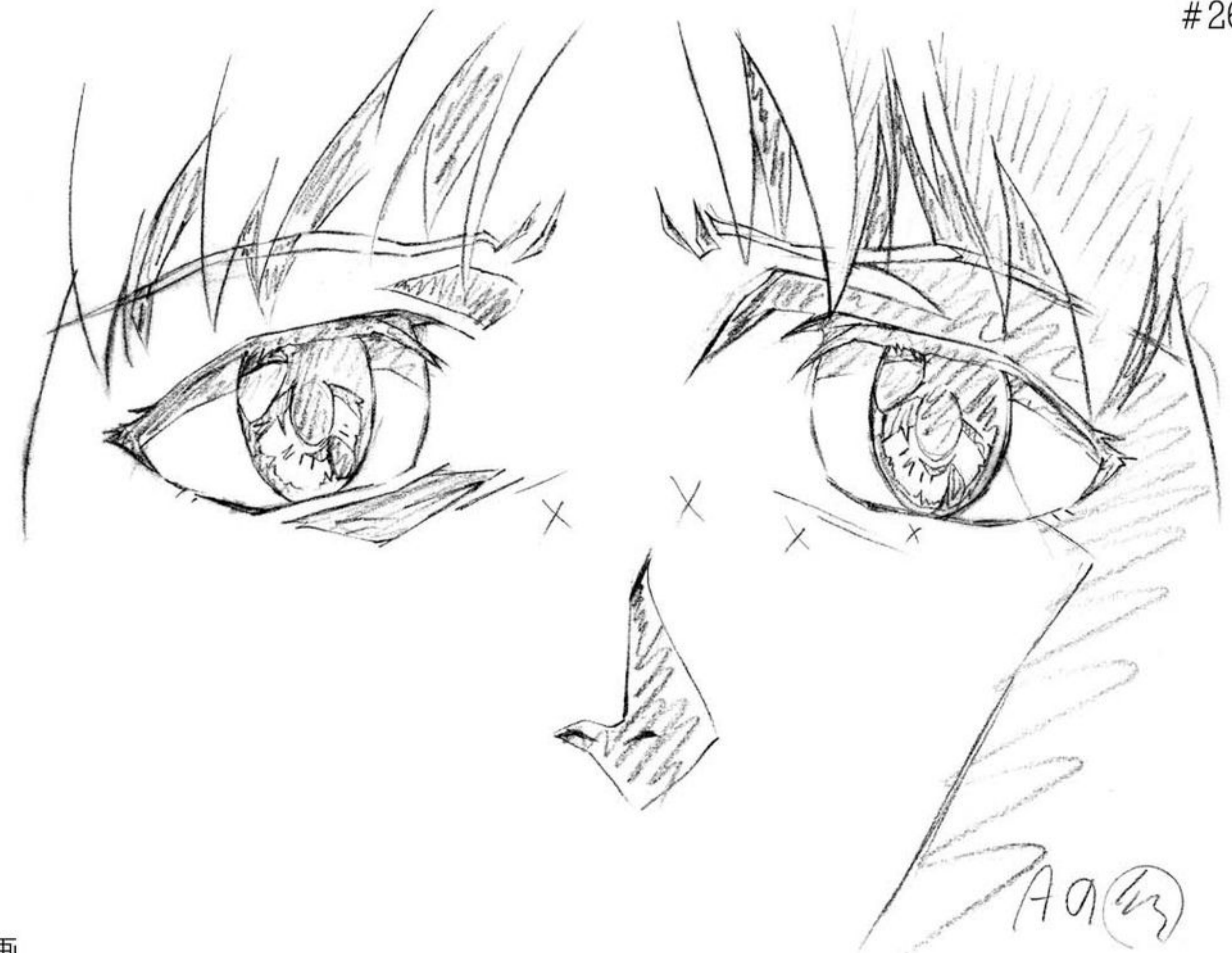

A9(43)

修正原画

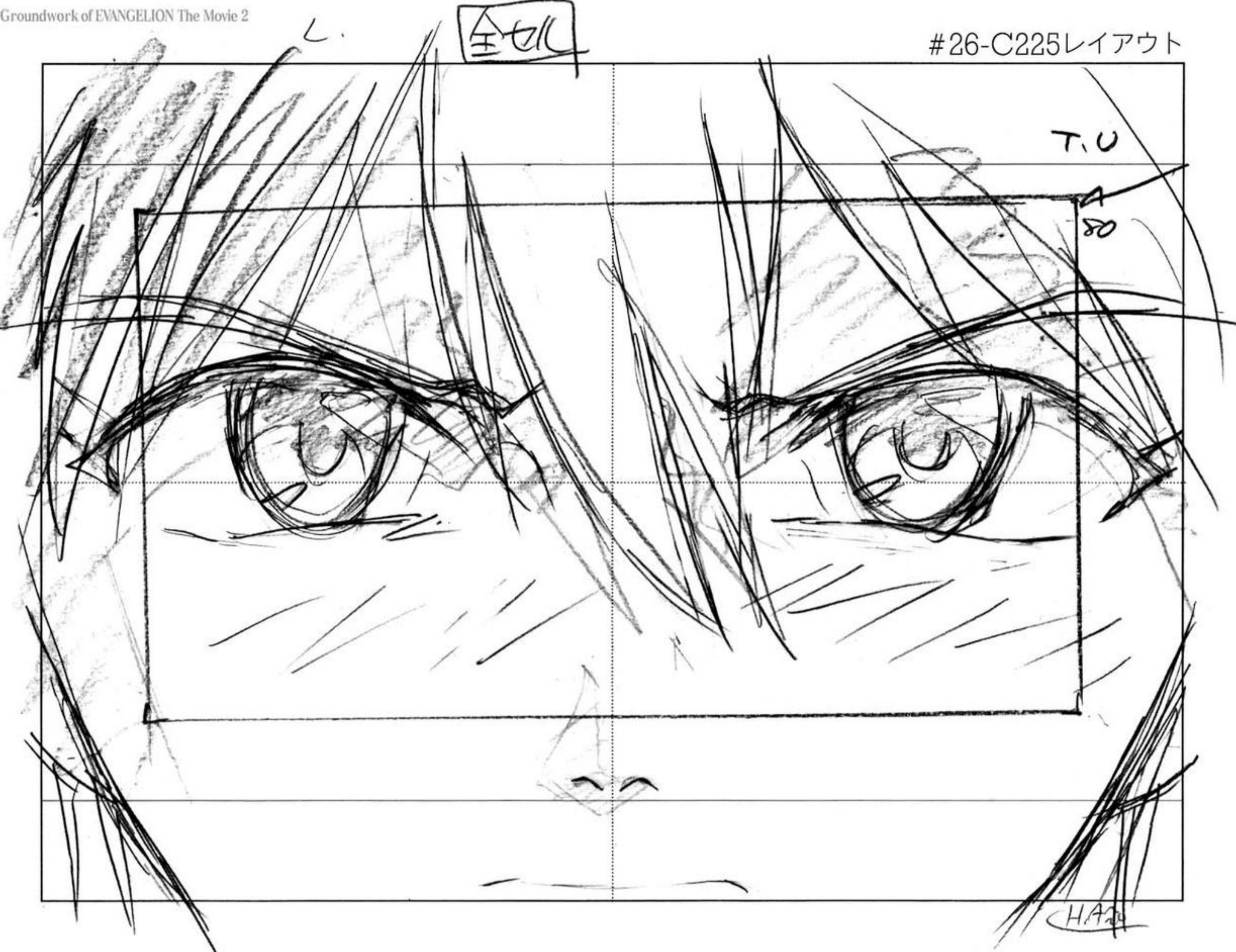

修正原画

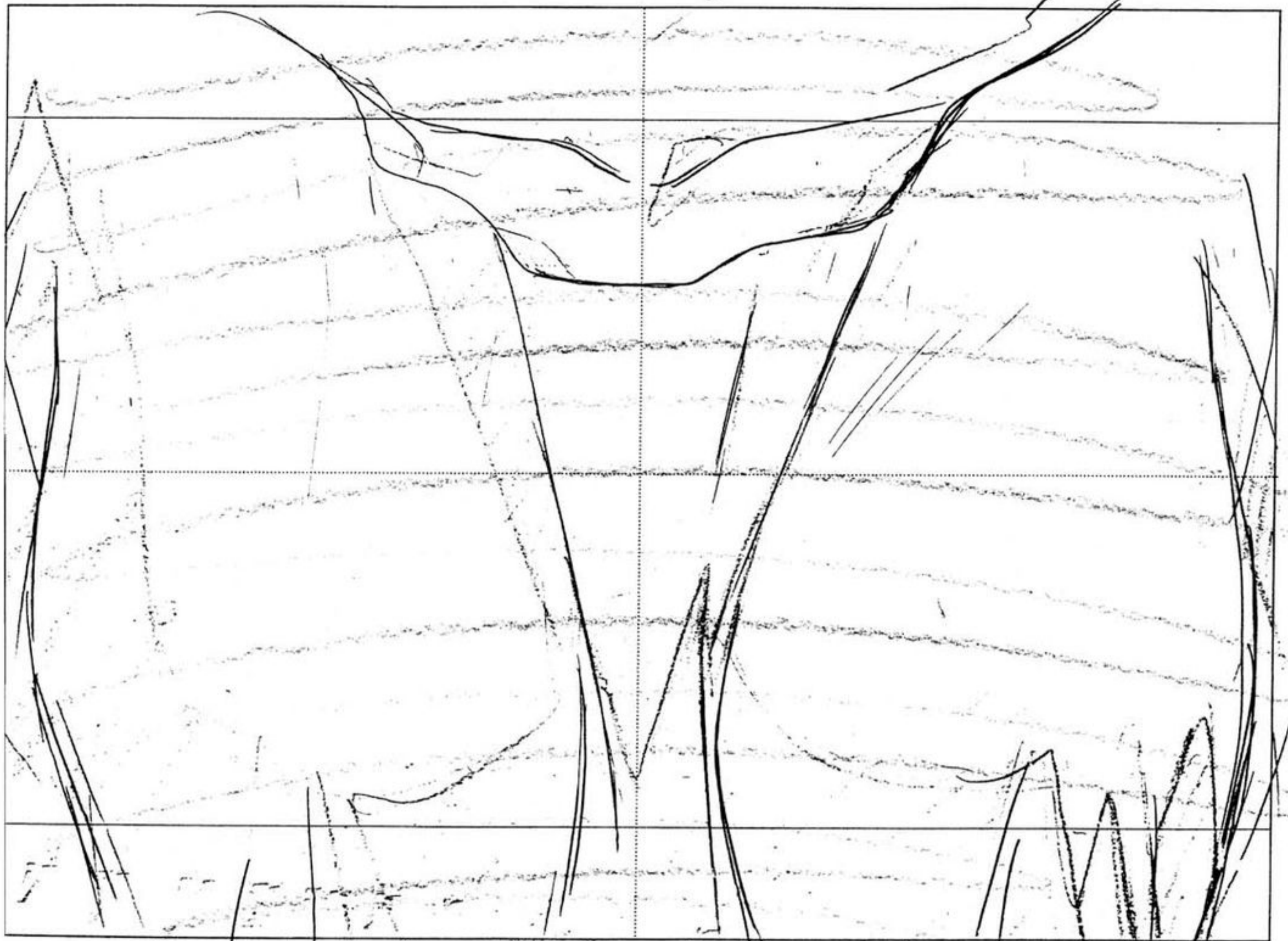

#26-C226レイアウト

CHIAO

#26-C226



AOKI

HI 薄め

修正原画



#26-C227レイアウト

#26-C227



修正原画

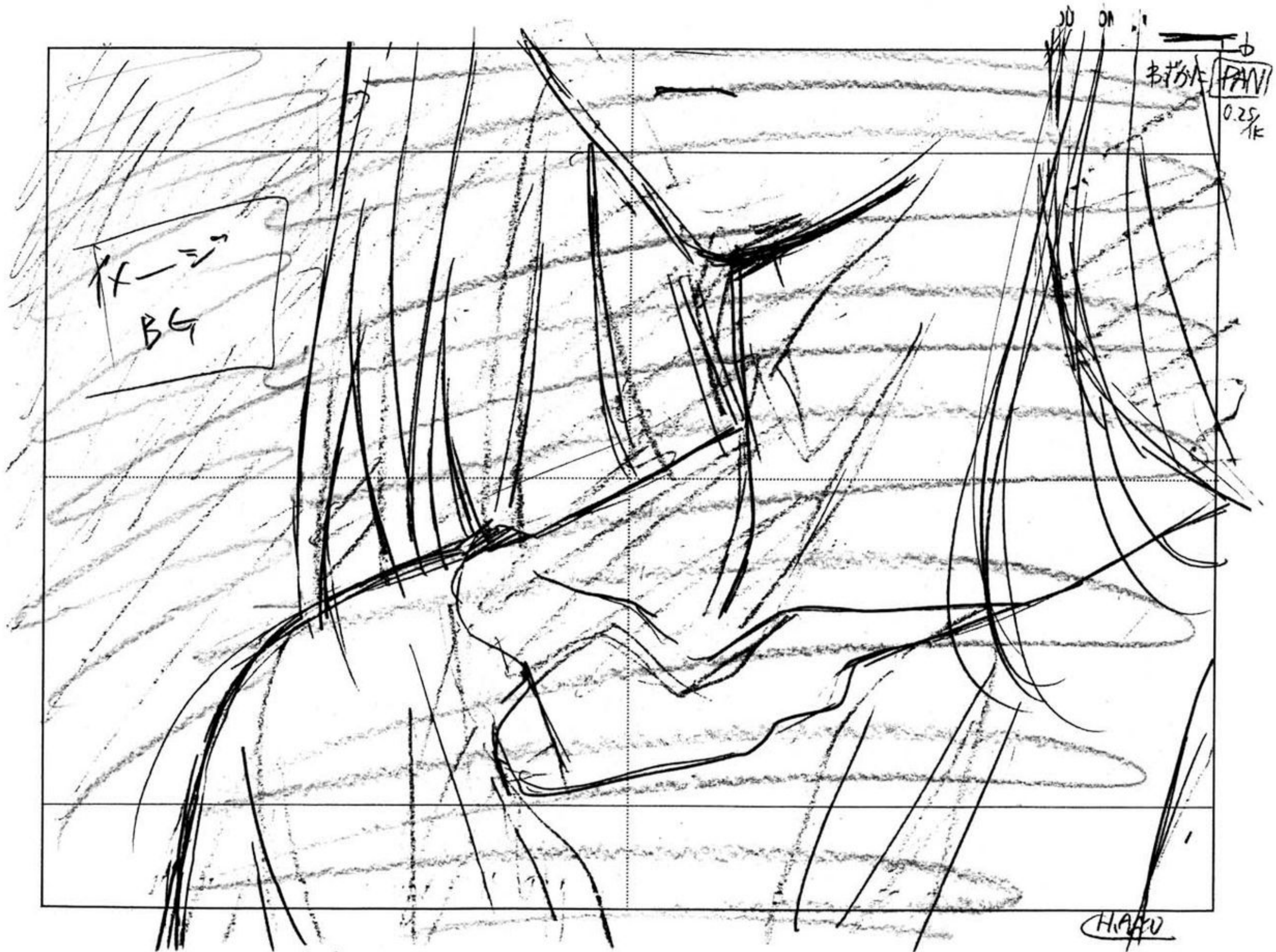

#26-C228レイアウト

#26-C228

AD
w



修正原画

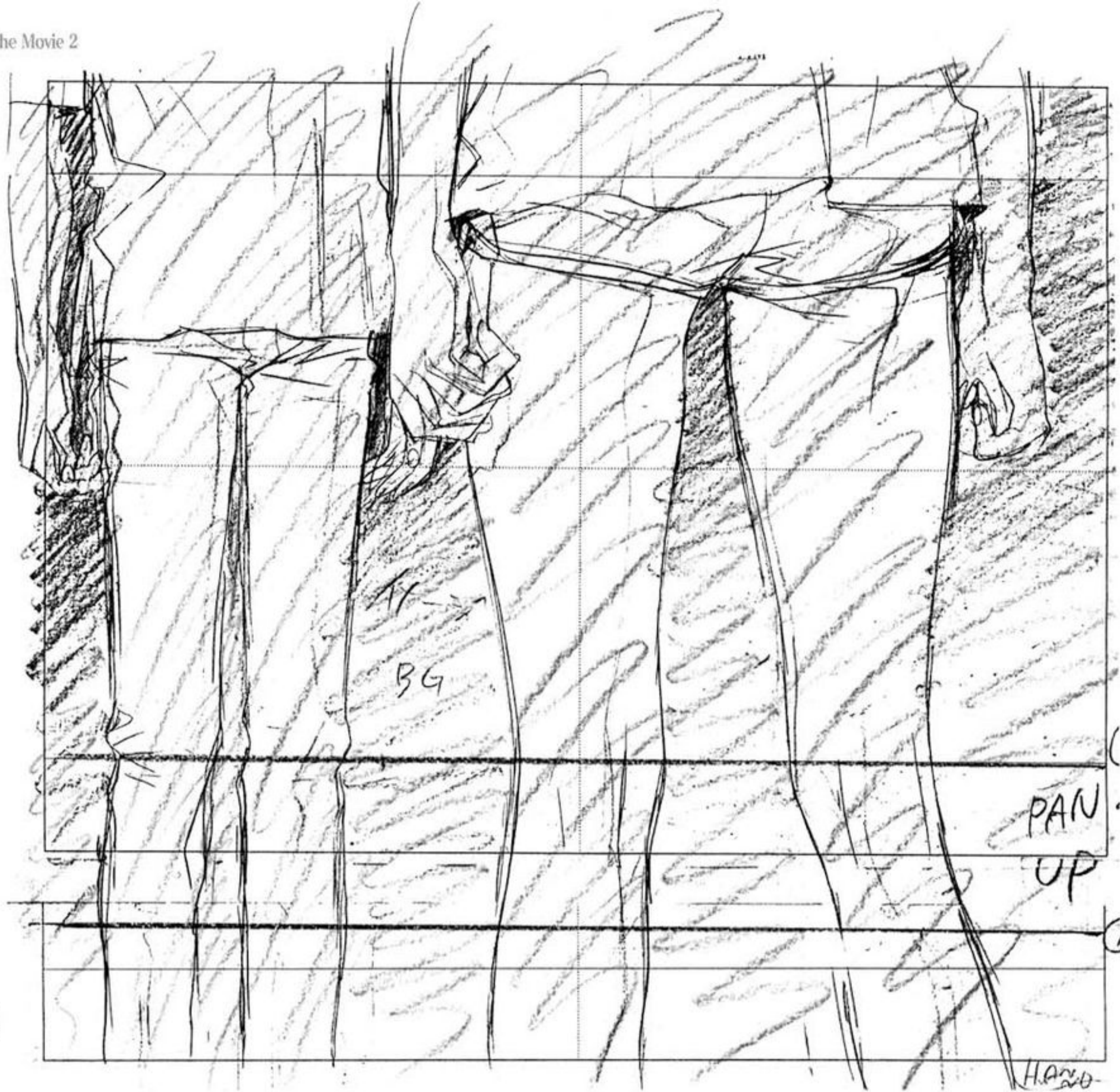

#26-C229
レイアウト

#26-C229



修正原画

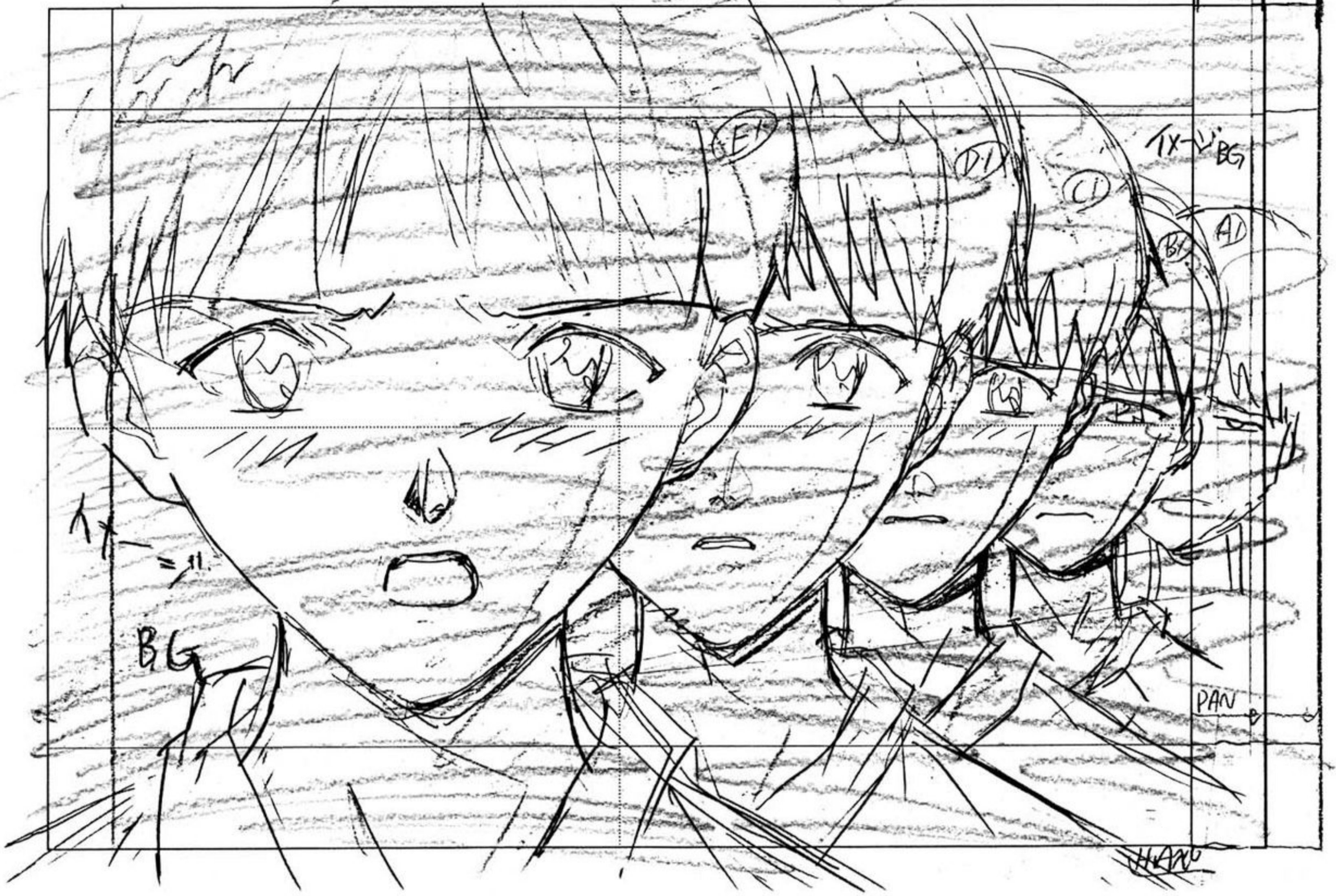

#26-C230



EのW

撮影指定

DF (A) → (B)
 A ~ Full 窓着引
 (E. Full の 同 97 等引)

E. Full →
 Dull →
 Cell →
 Bell →
 A ち →

o.T.B 95 → 100
 (09-)



A
D



B
D





40252° 43C
4.92

シシモナーの
...モリオの大き?

修正原画

#26-C240

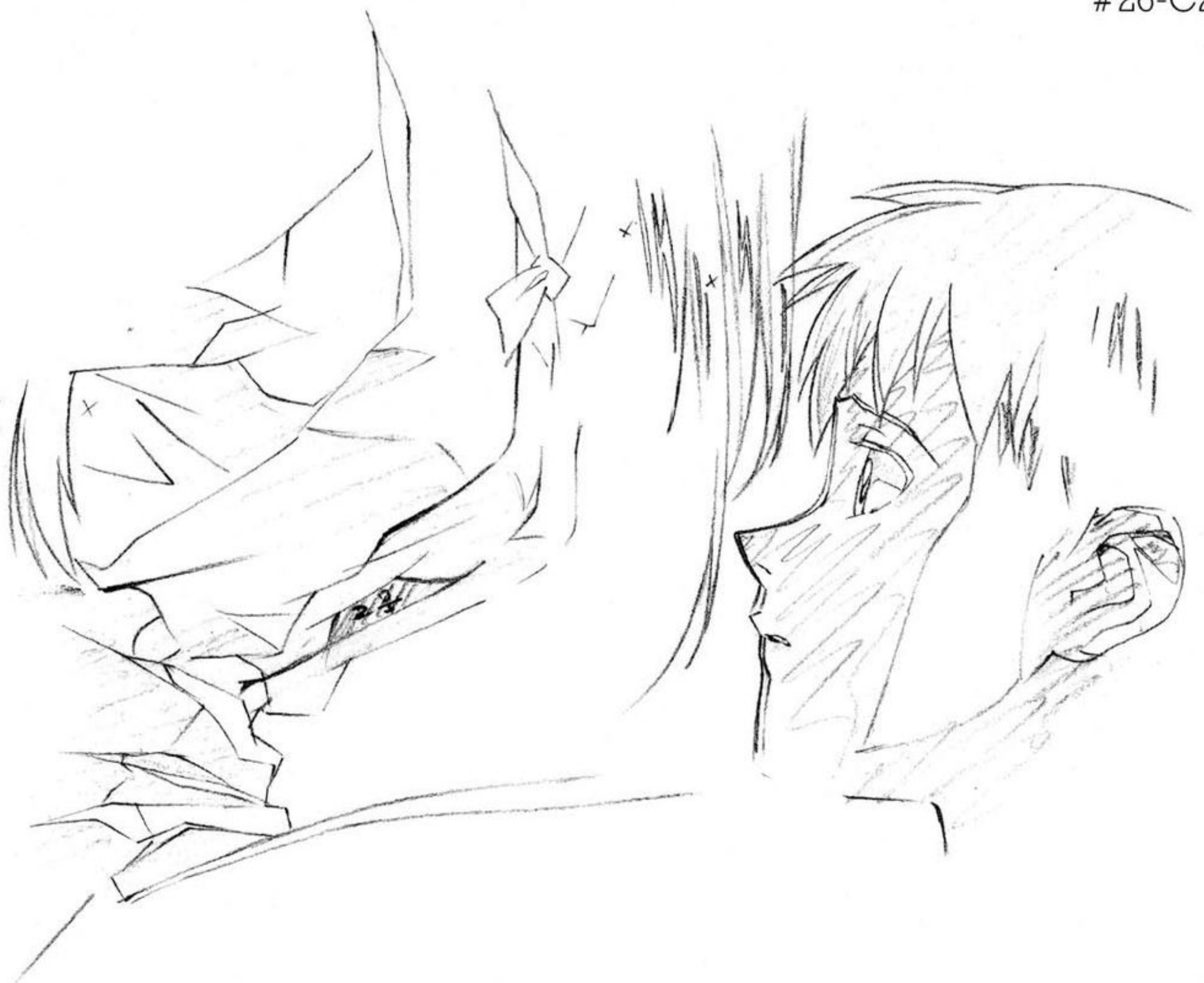

#26-C241,247レイアウト

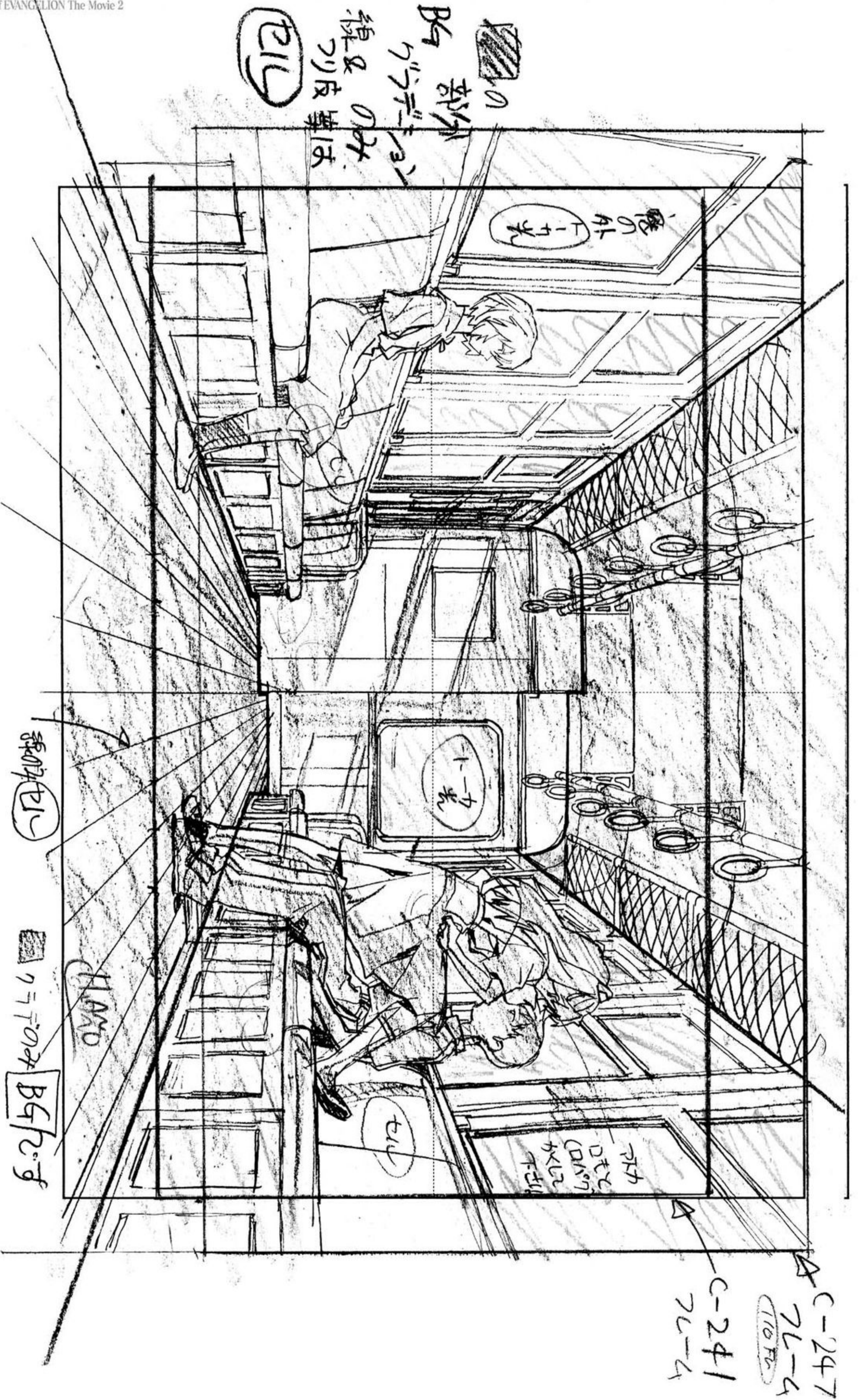

いまは、このまじりこみでいい感じ。いまは、このまじりこみでいい感じ。

4年前のファッションエッセイ。

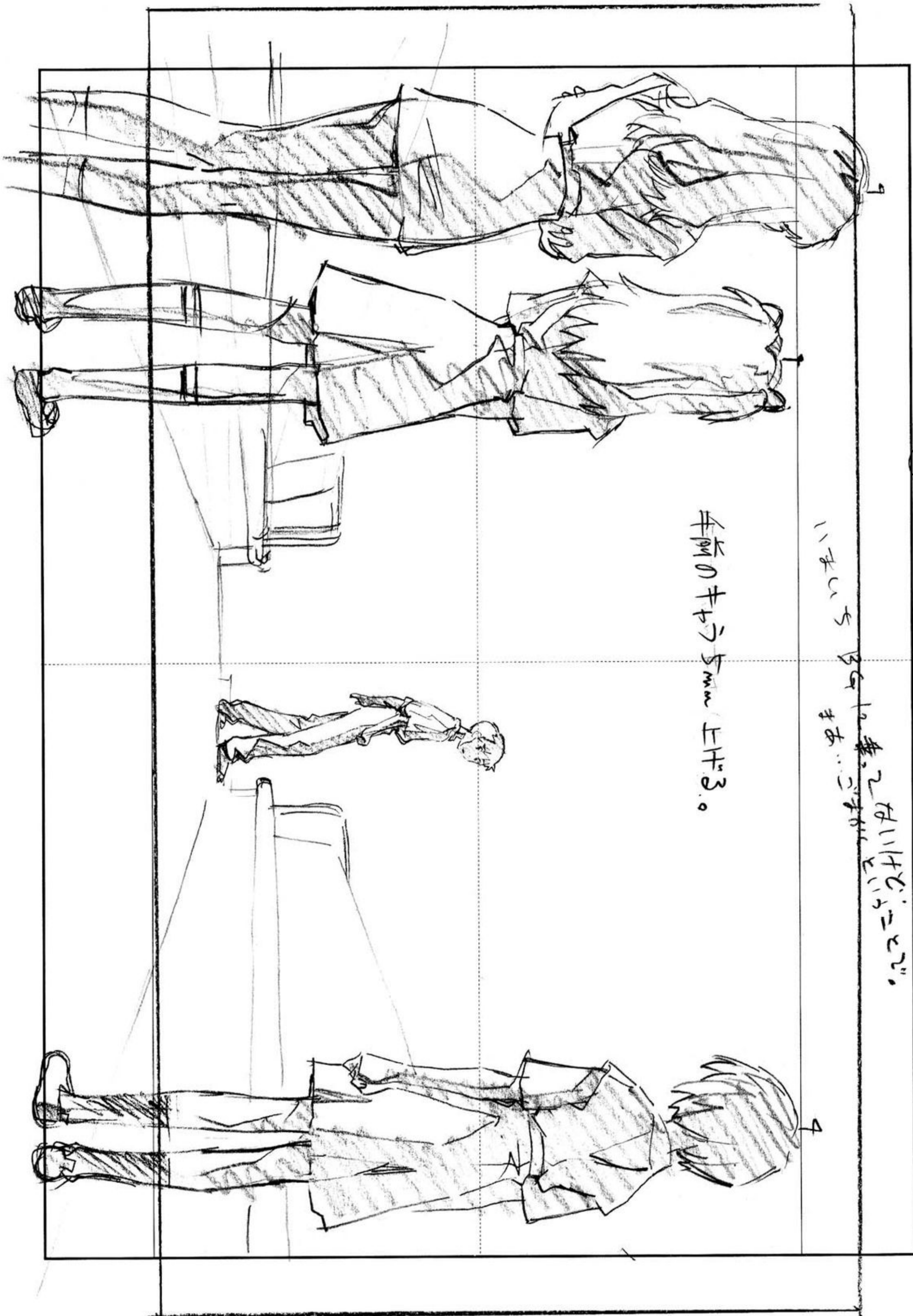

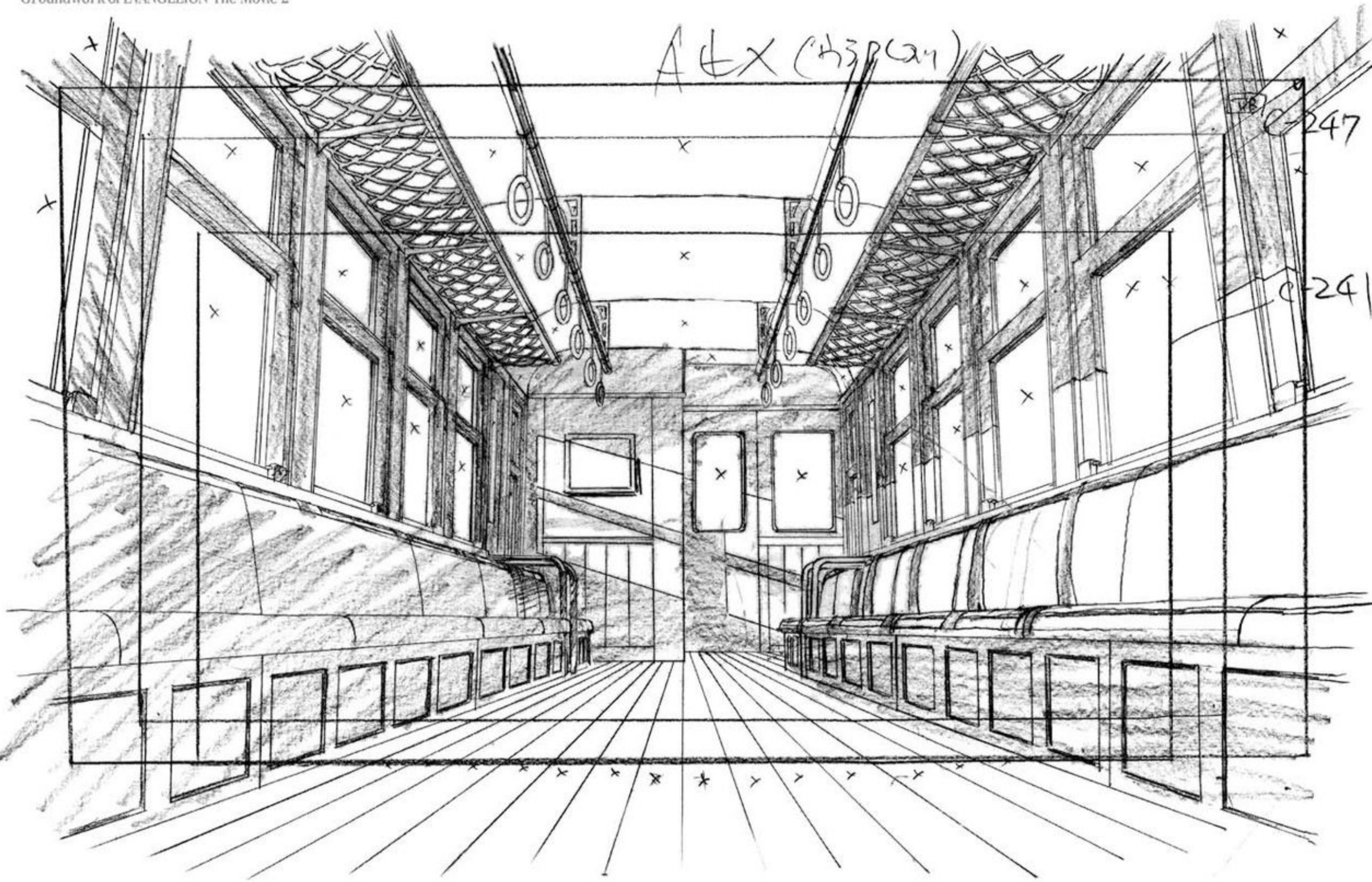

#26-C241,247

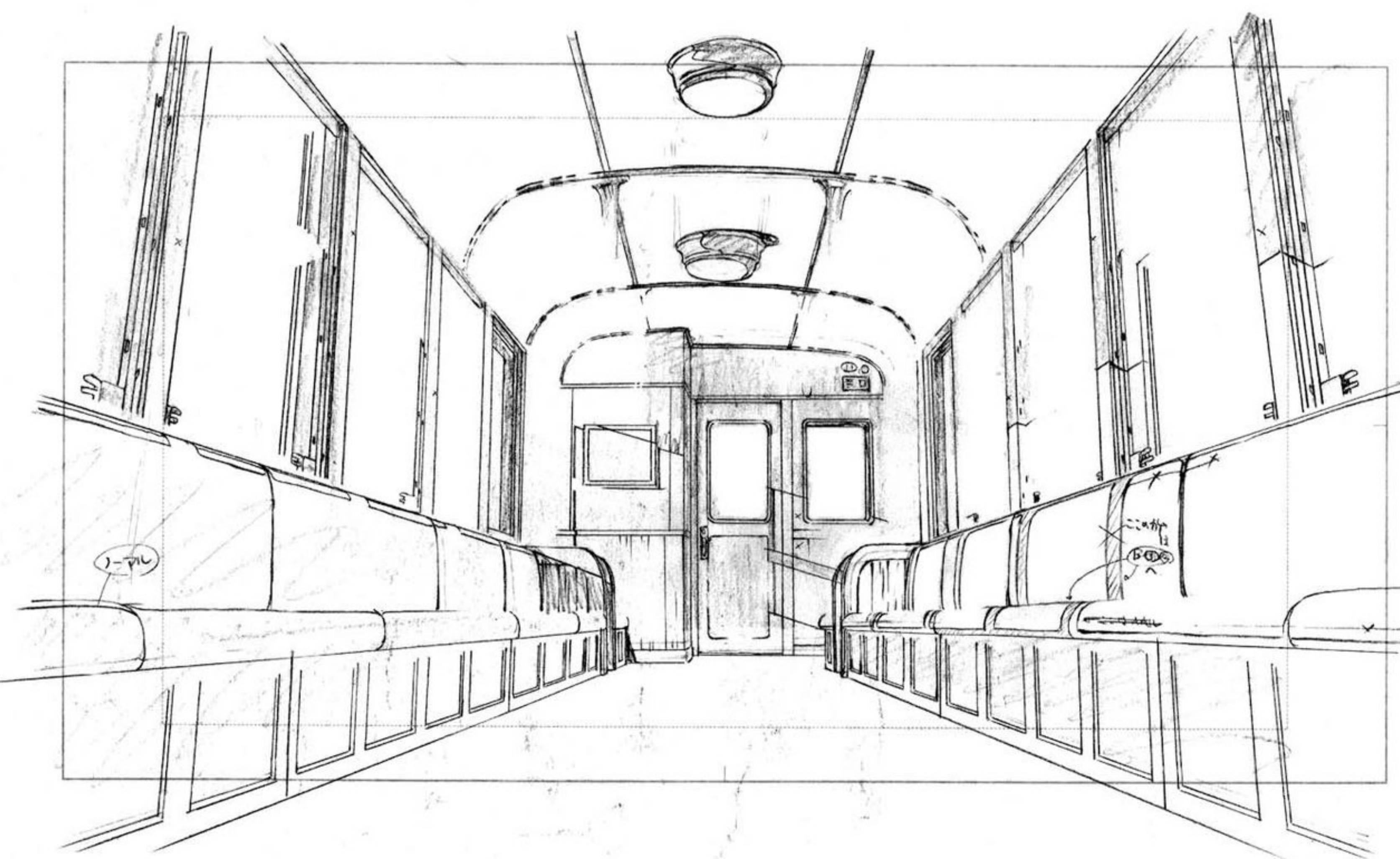

修正原画

1

はーBCLay



修正原画

BD



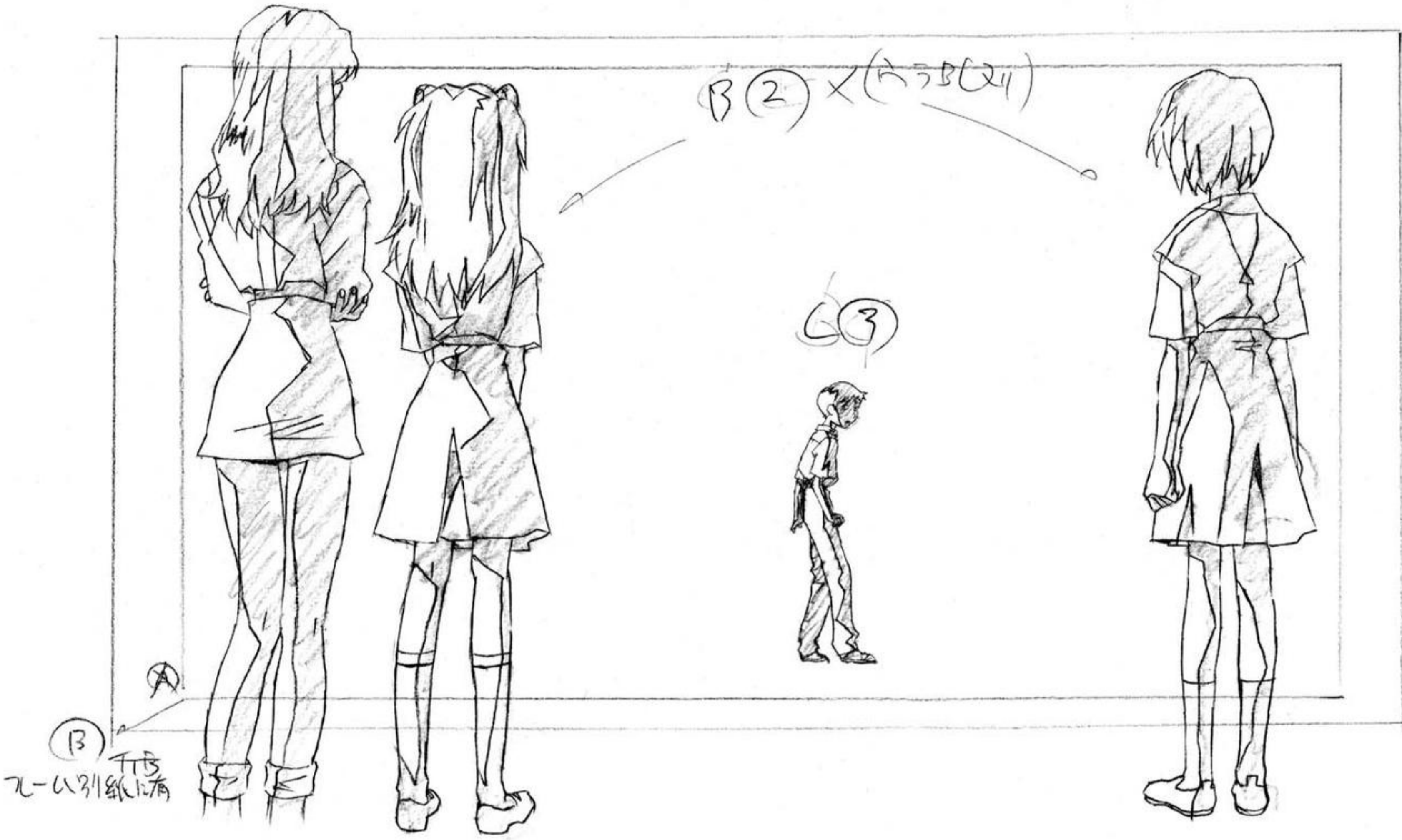

修正原画

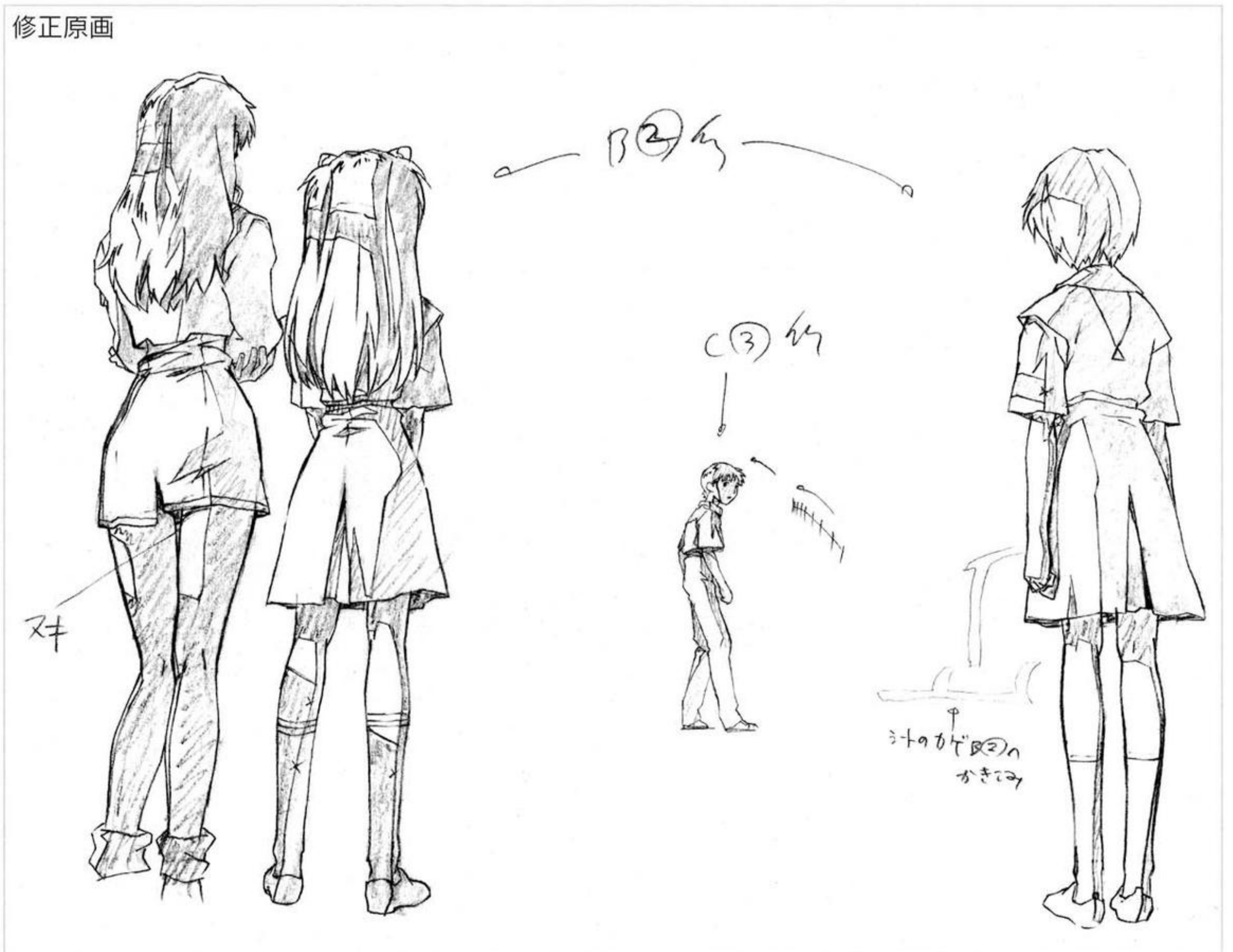

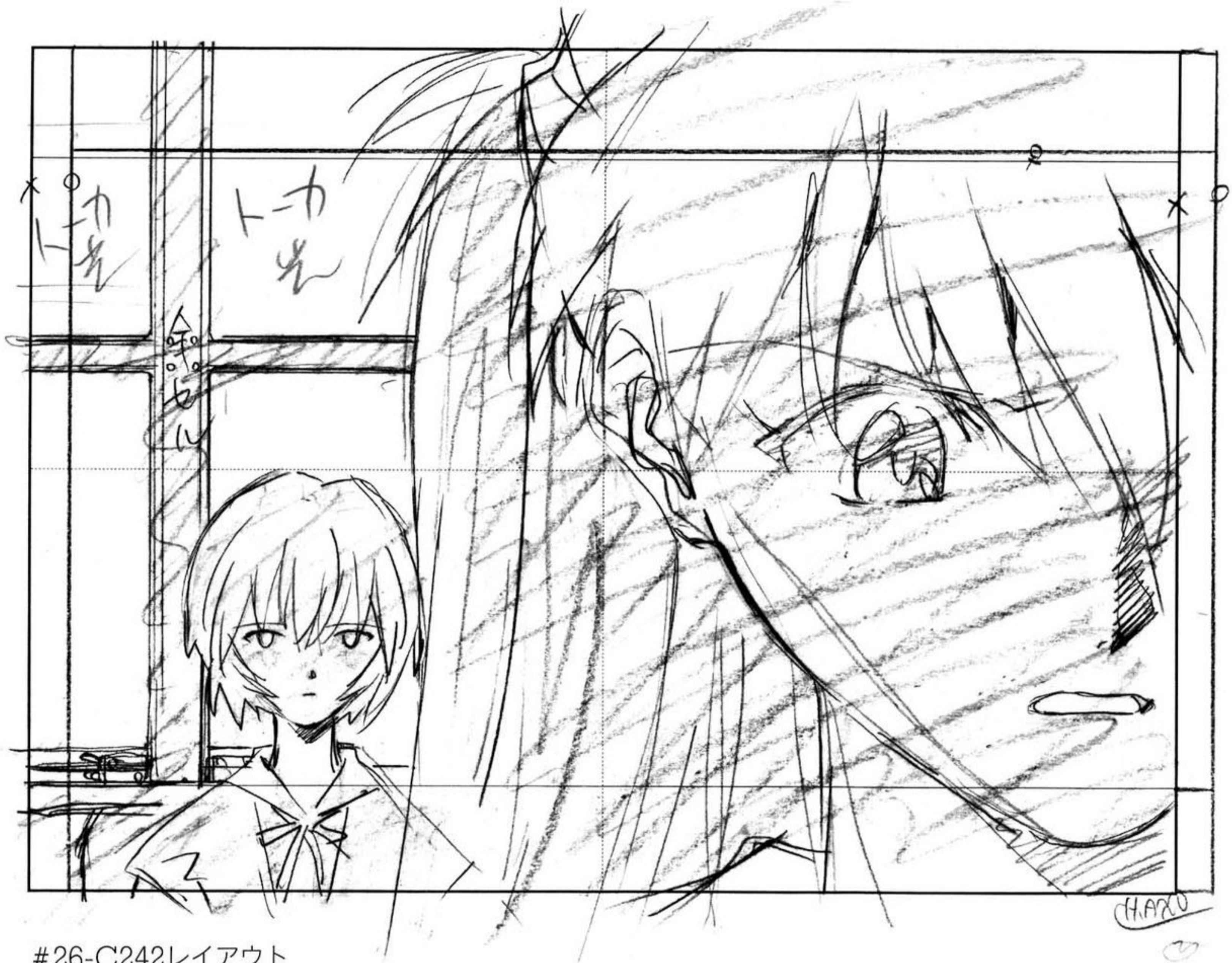

#26-C242レイアウト

#26-C242



修正原画

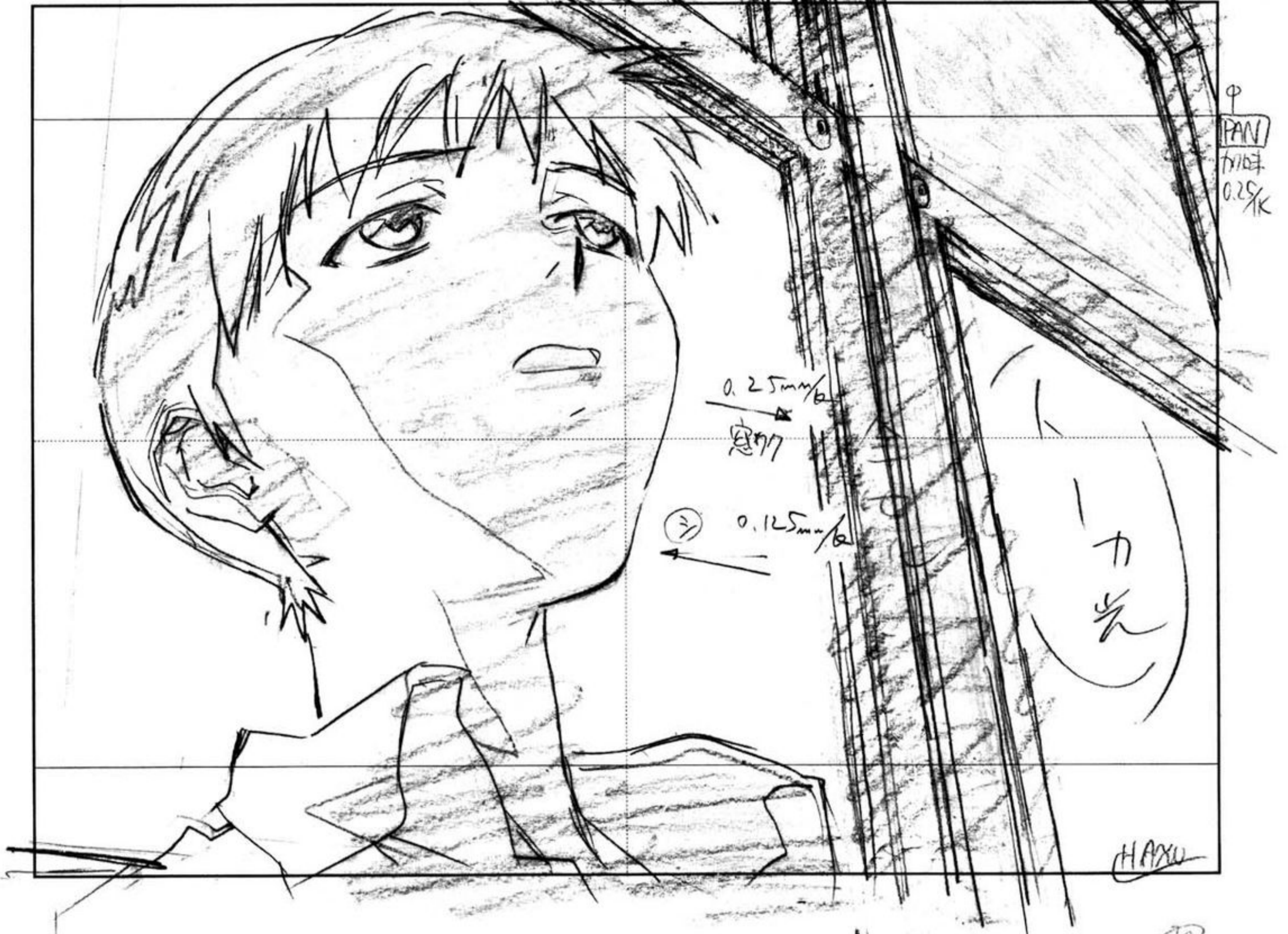

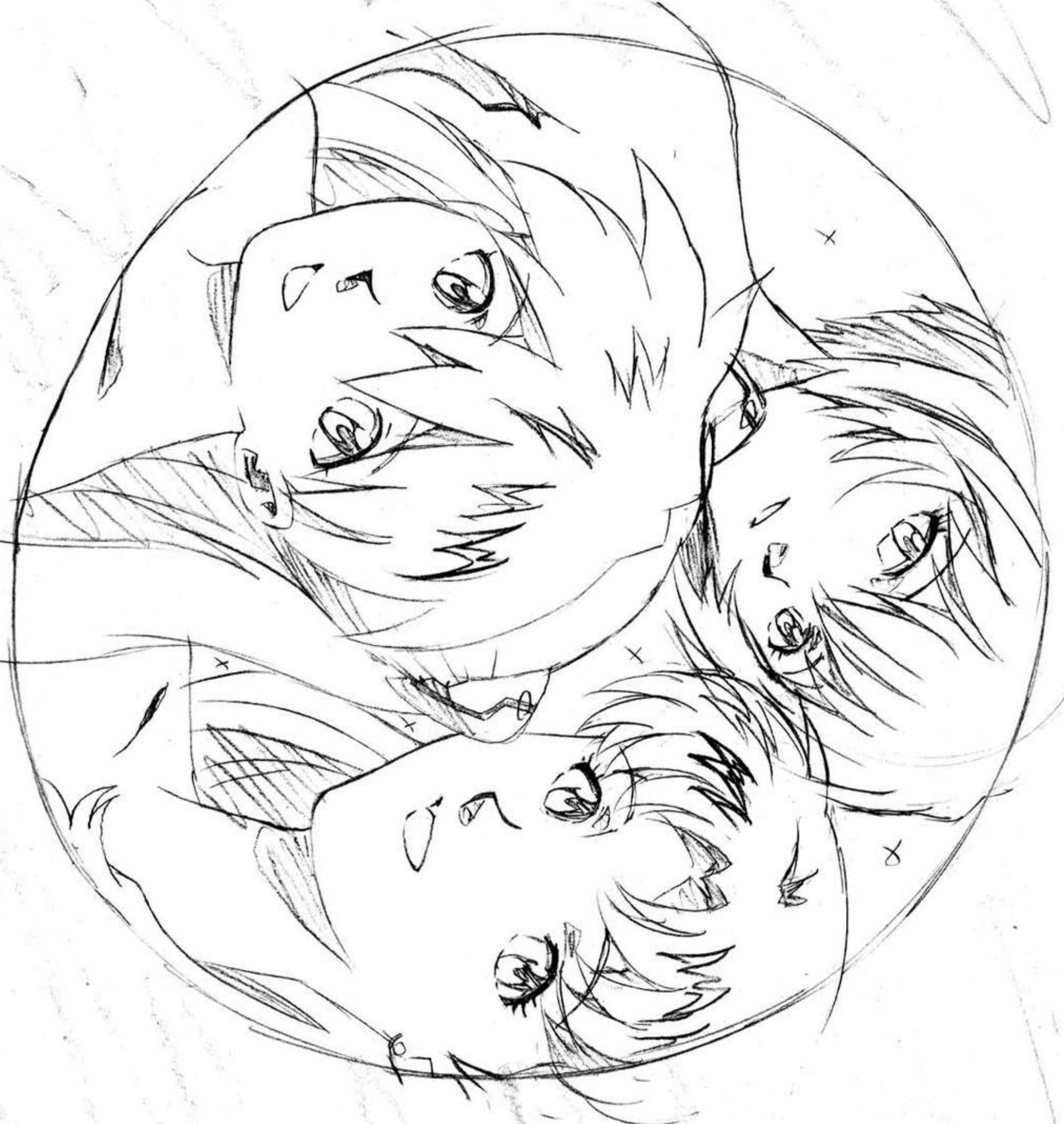

BLRy

D /



D-2

ALY
14/09





ALEX
10/10

D4

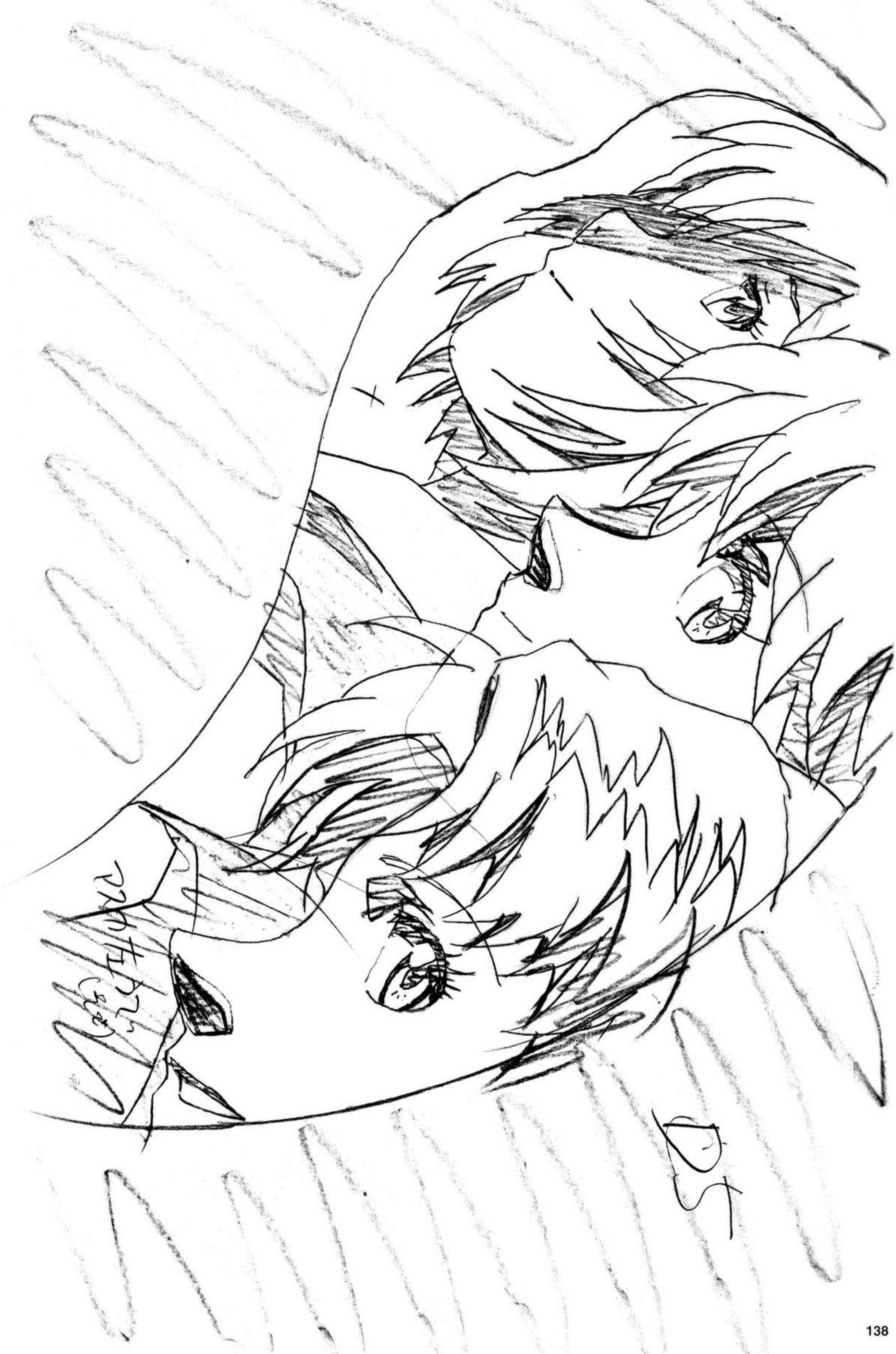

224#172m

DS



26

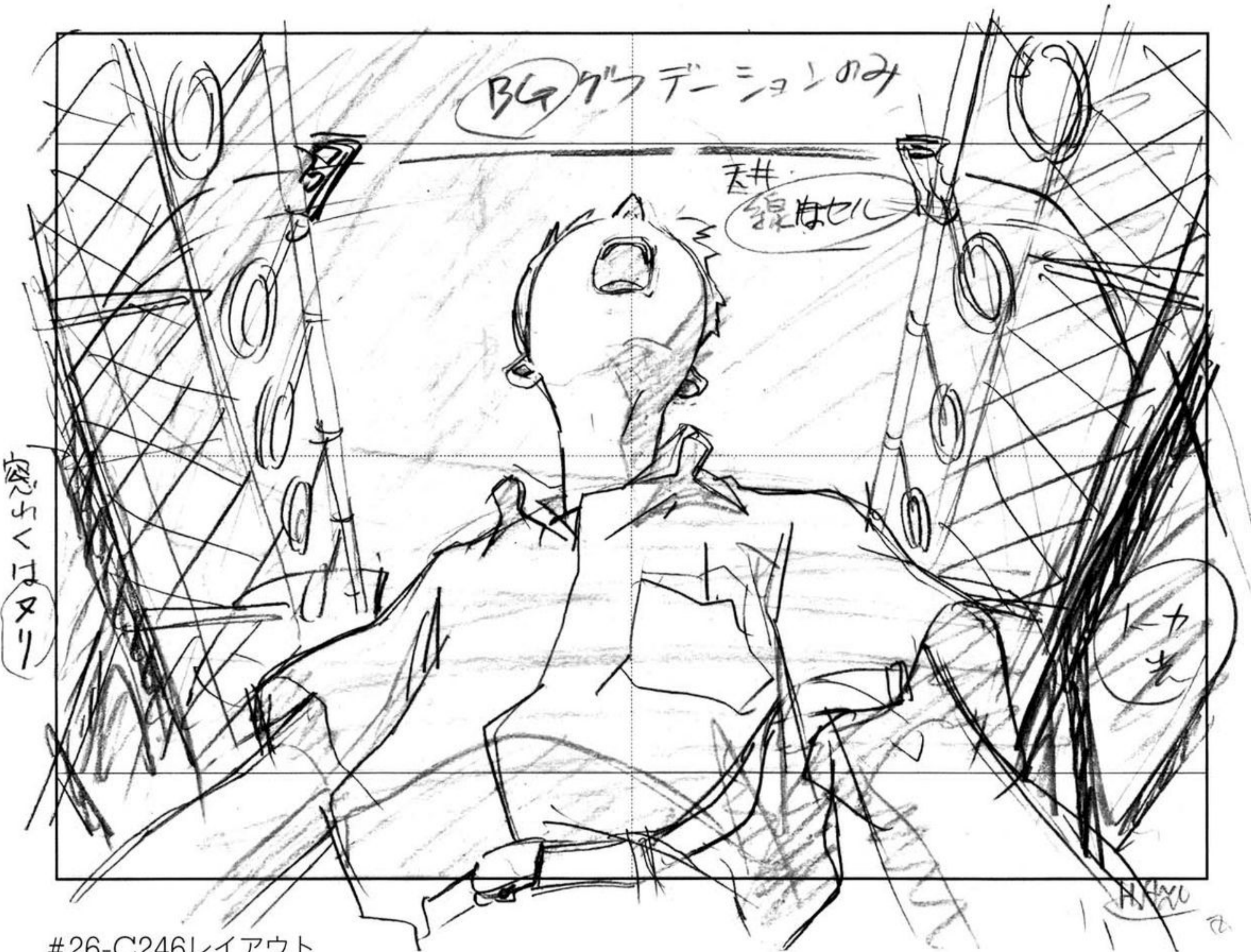



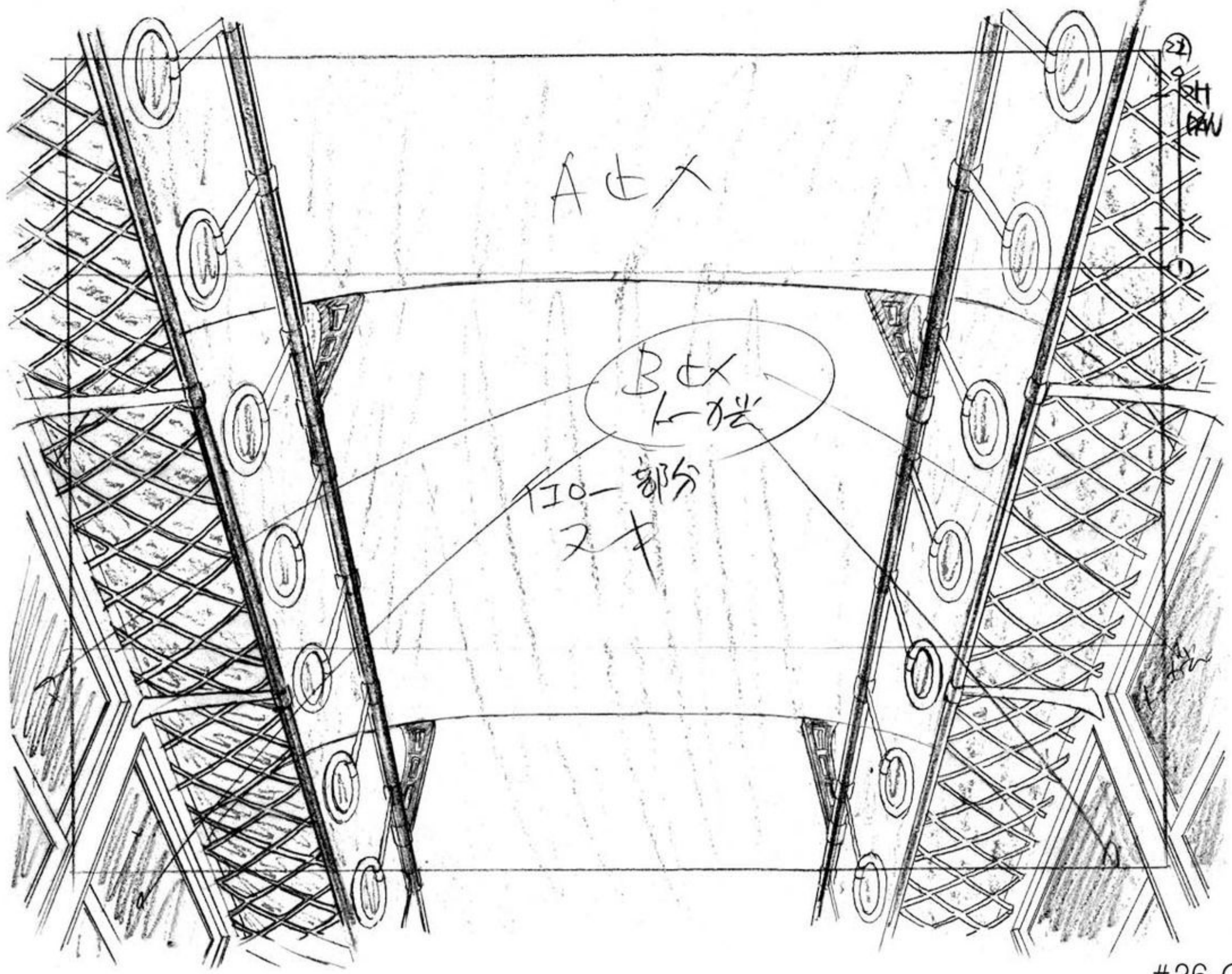

#26-C246

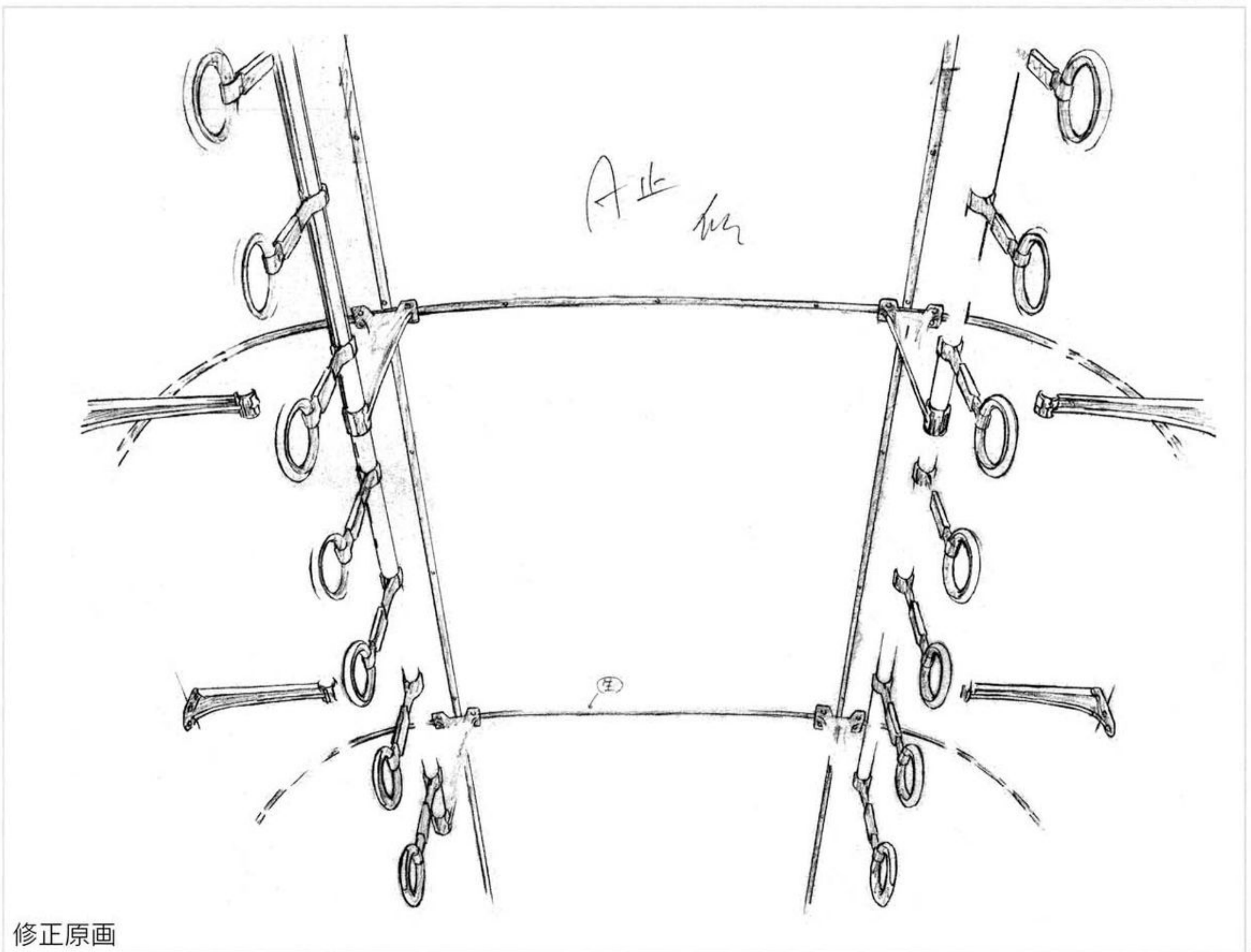

修正原画



修正原画





修正原画





修正原画



(17)



修正原画





修正原画





修正原画



27



修正原画

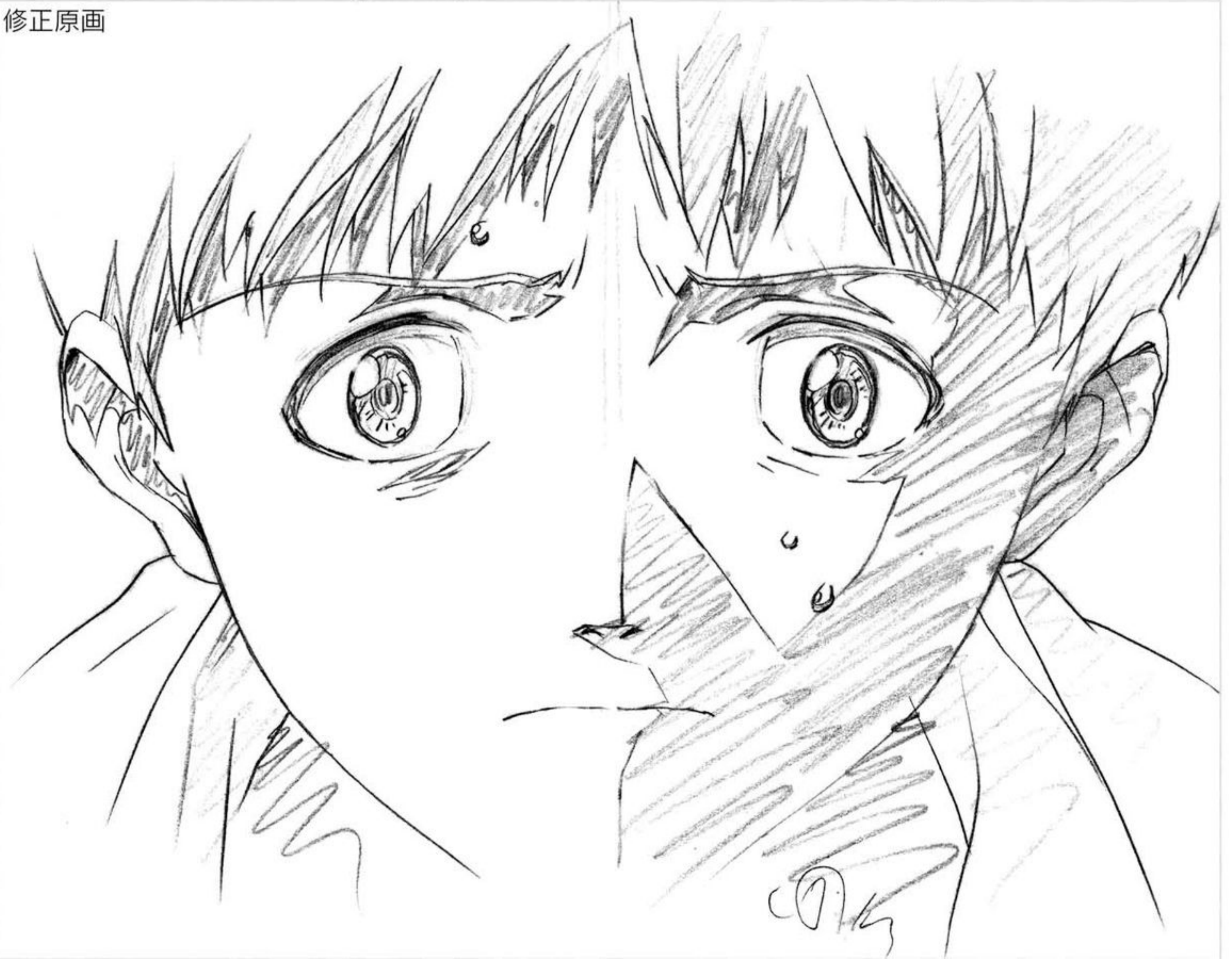

C.D.K.



修正原画

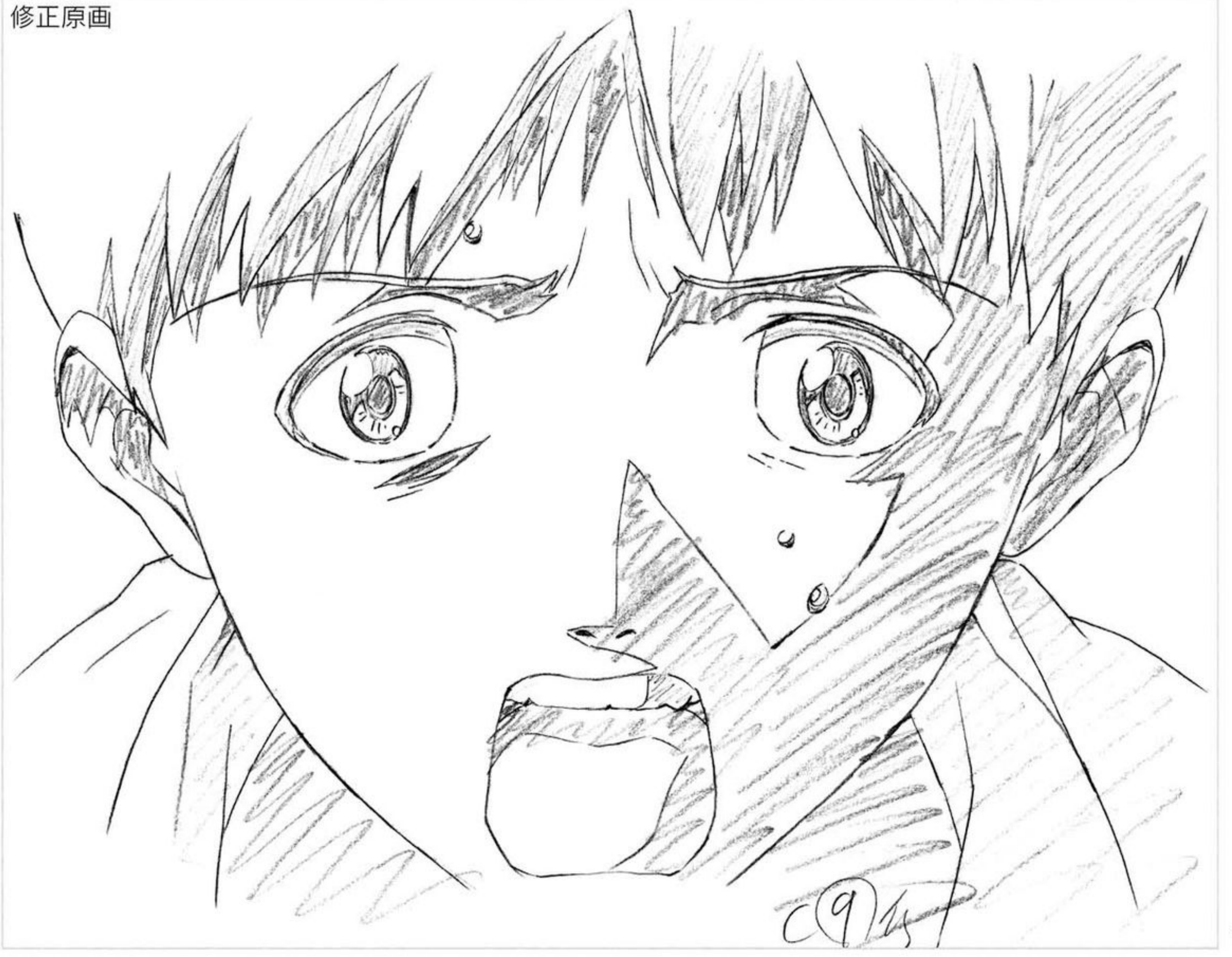

C9/15

同紙ダ
↑1mm
上1/2
下1/2
C10A

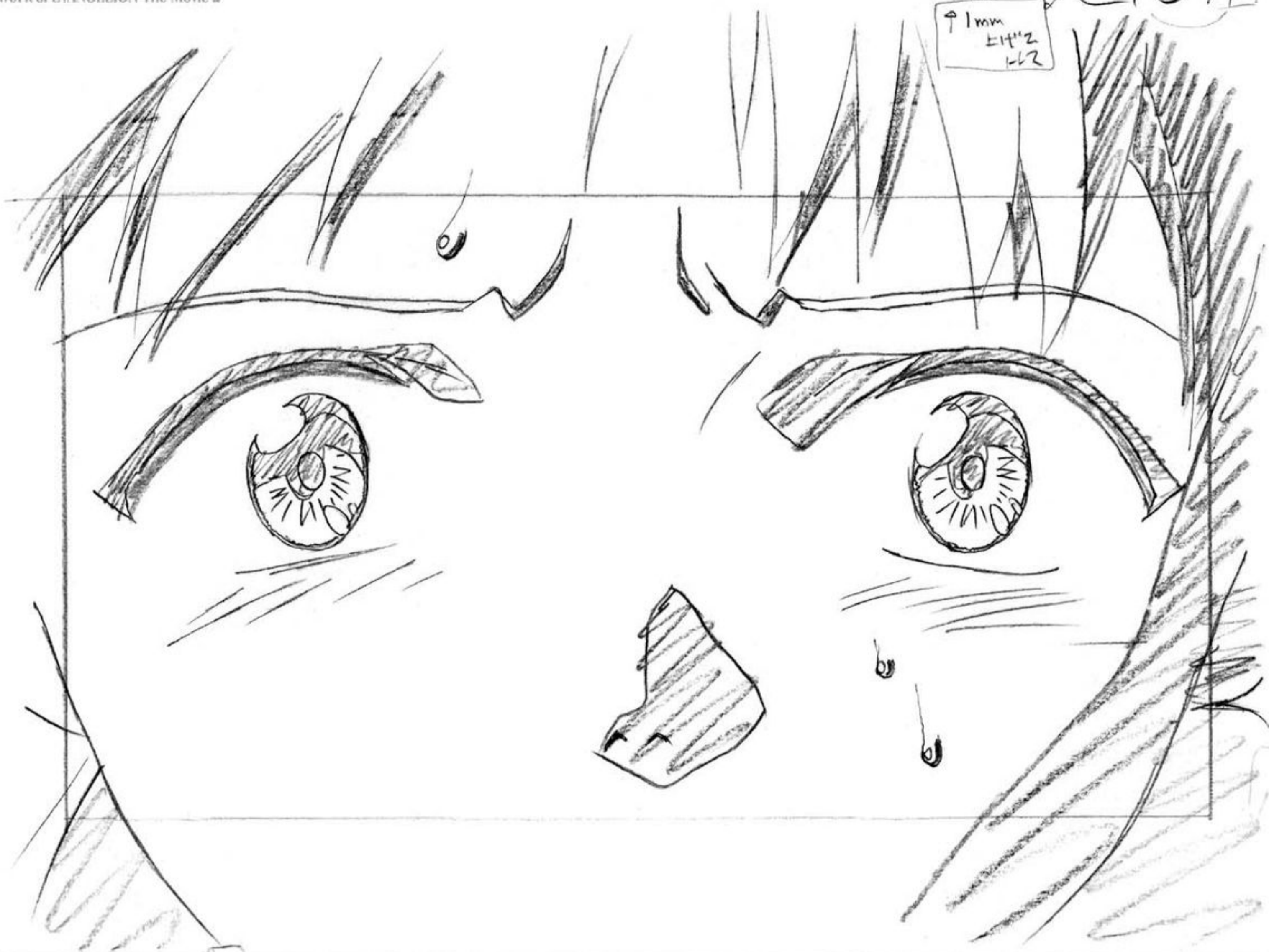

修正原画

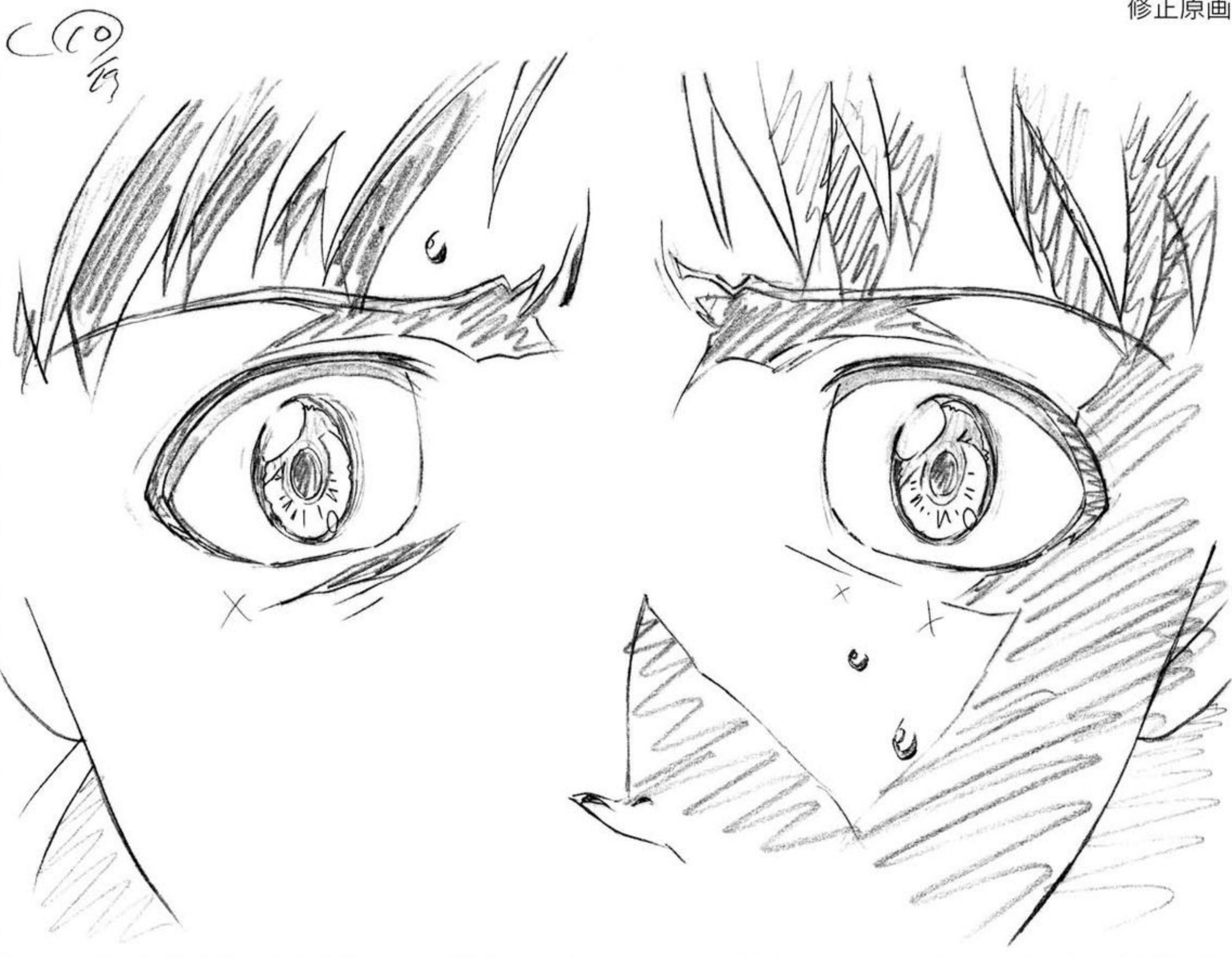

C10
1/3

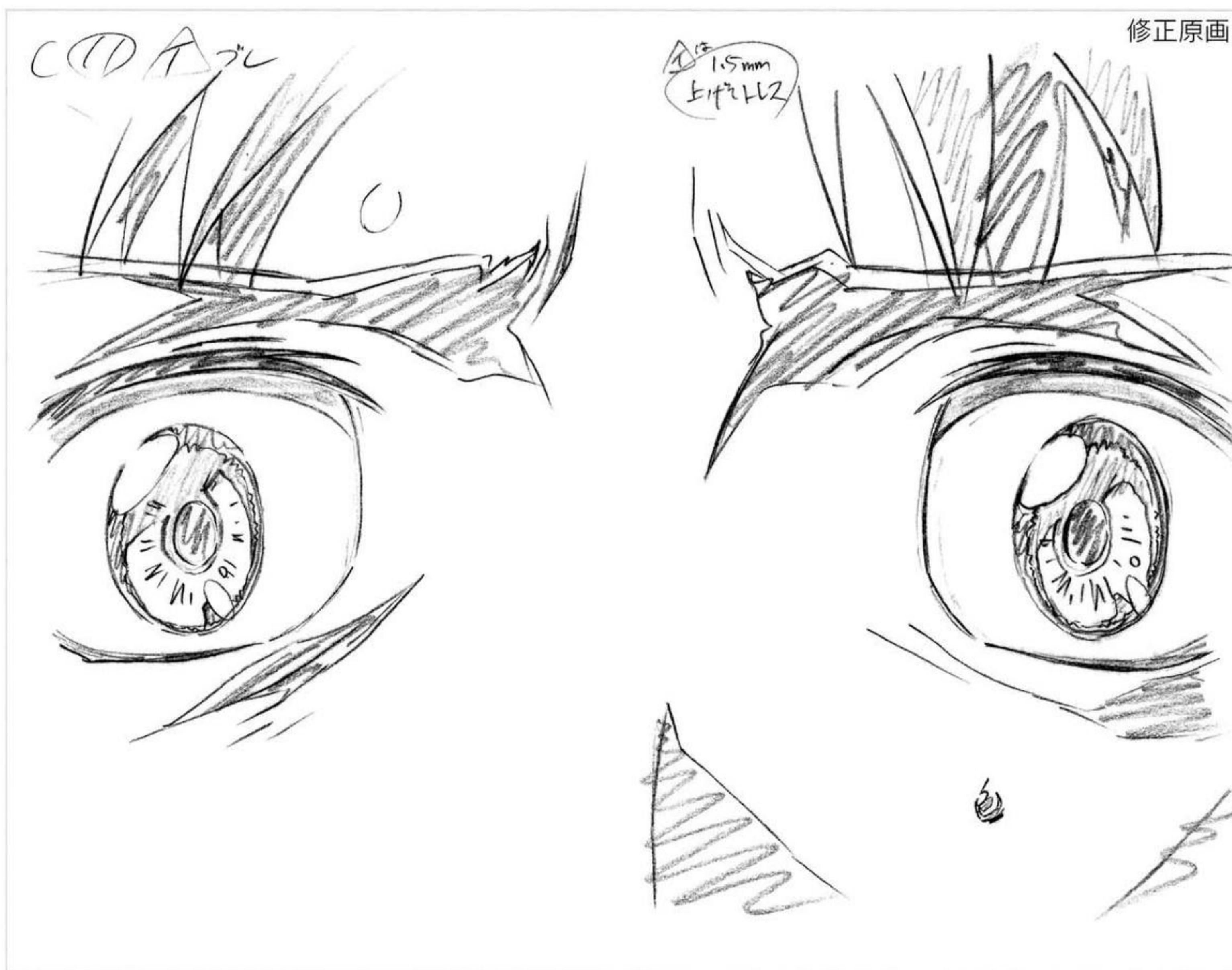
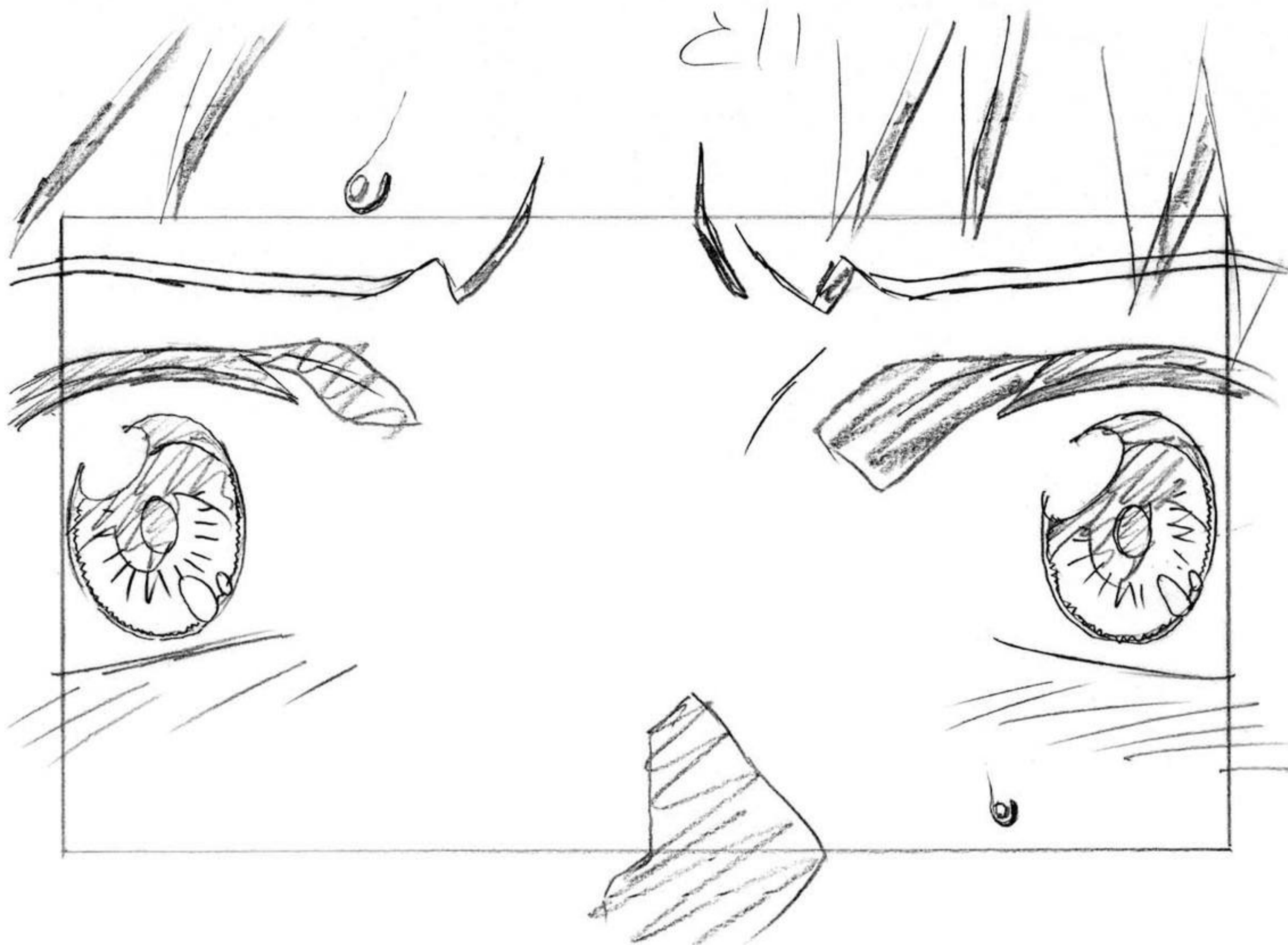

修正原画

CCD A 7L

△ 1.5mm
上げられ



#26-C248レイアウト

修正原画

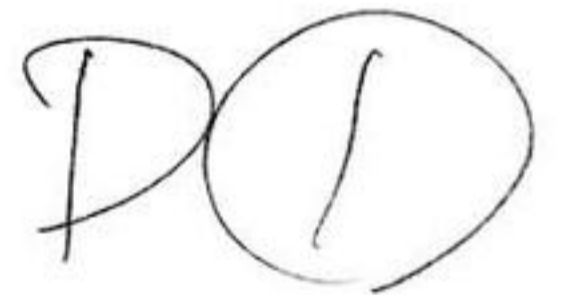

#26-C248



△



φ017

△②

修正原画

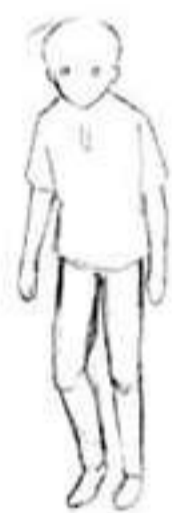

△



△②



△



△



①



②

③

修正原画



①



修正原画
②

③



②

④



①

修正原画



1.3時 日曜日
歩行
アタリ 足元 確認 (44) 811'9.12'22.22



歩行



修正原画



修正原画

修正原画
(0197294)
修正



修正原画

修正原画



修正原画



修正原画
修正

修正原画

修正原画

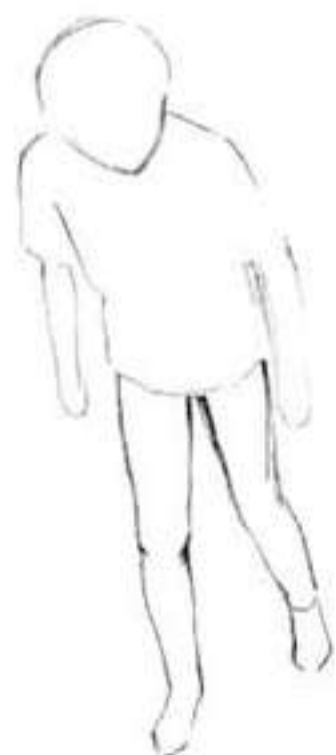

修正原画



修正原画

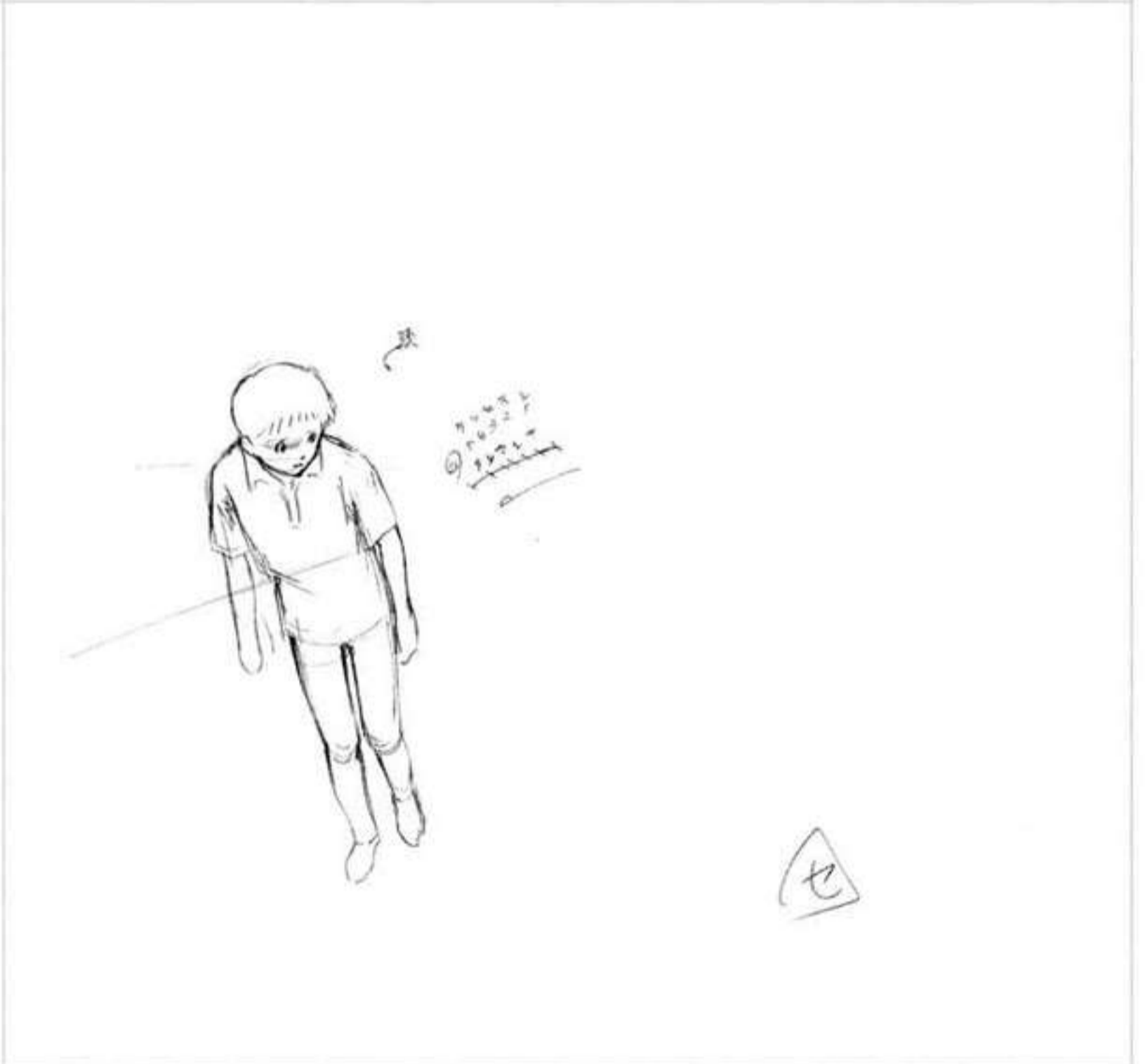
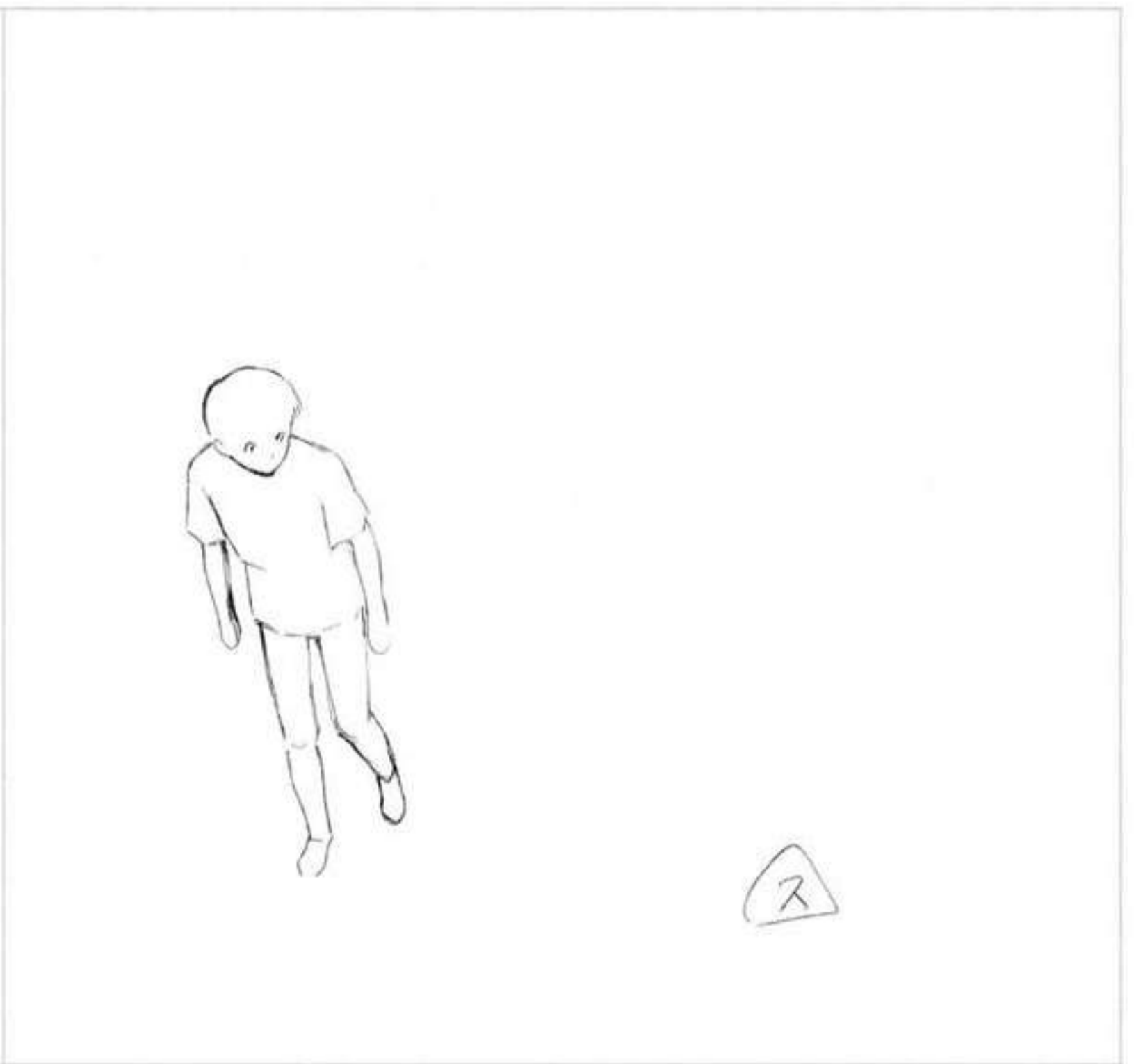
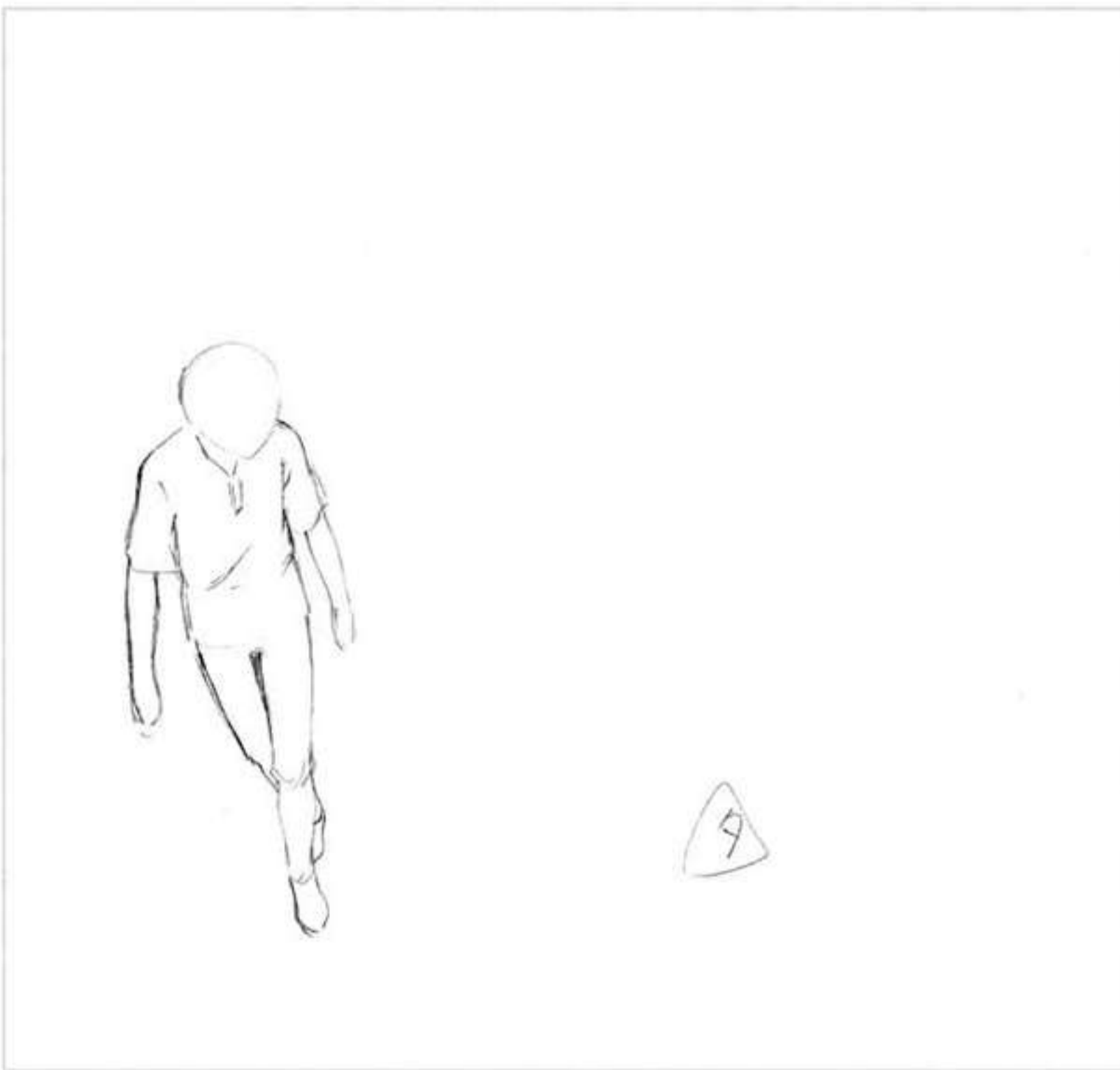



φ①⑦



①⑨

④①②④



修正原画



④②⑨

頭

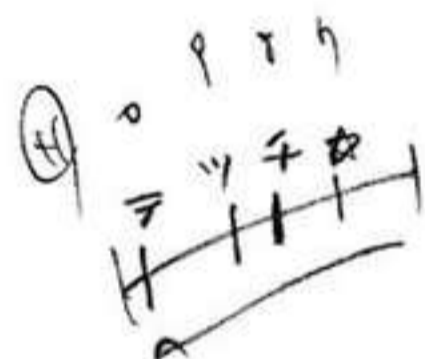

①⑨

④①②④



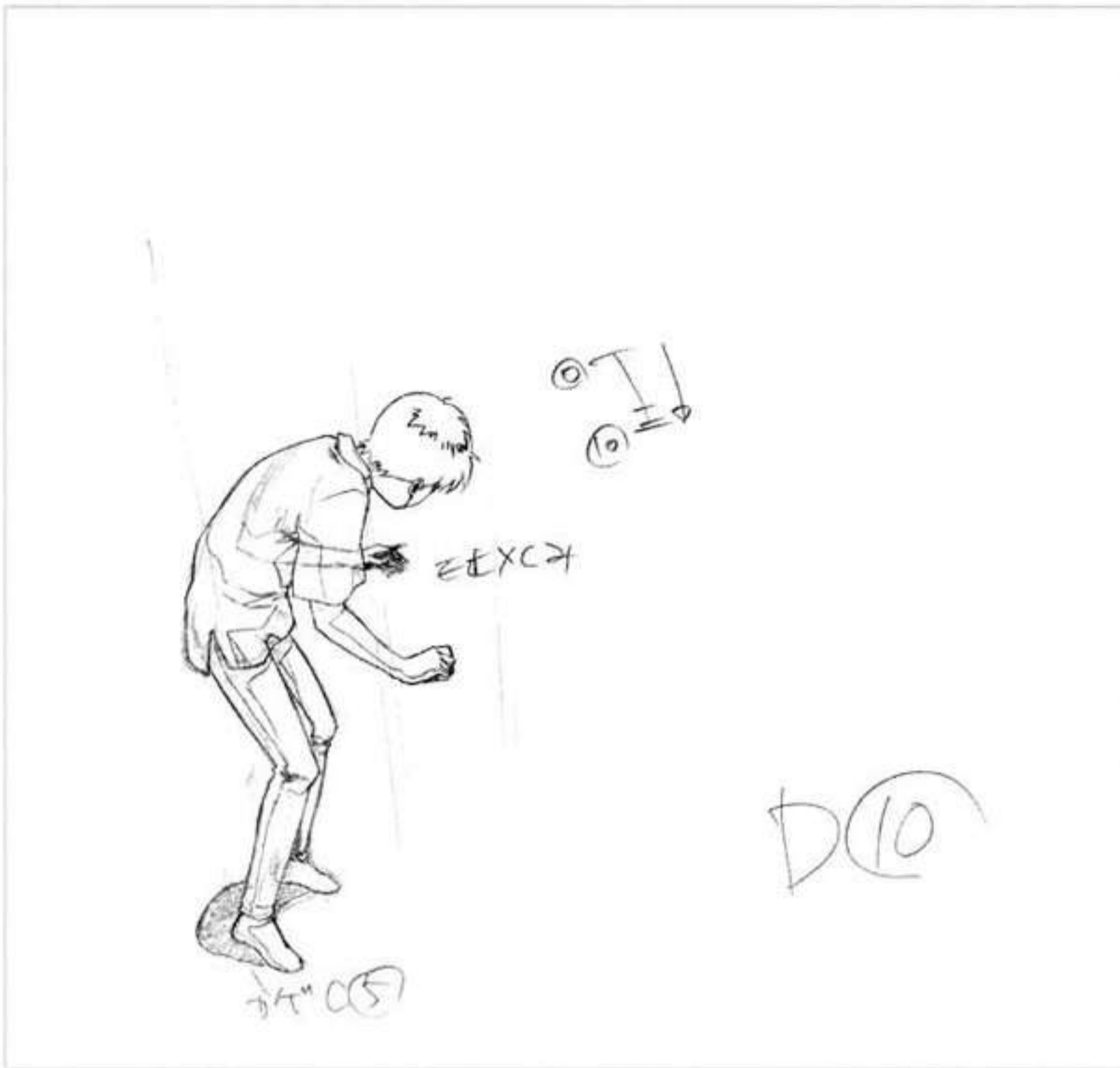

修正原画

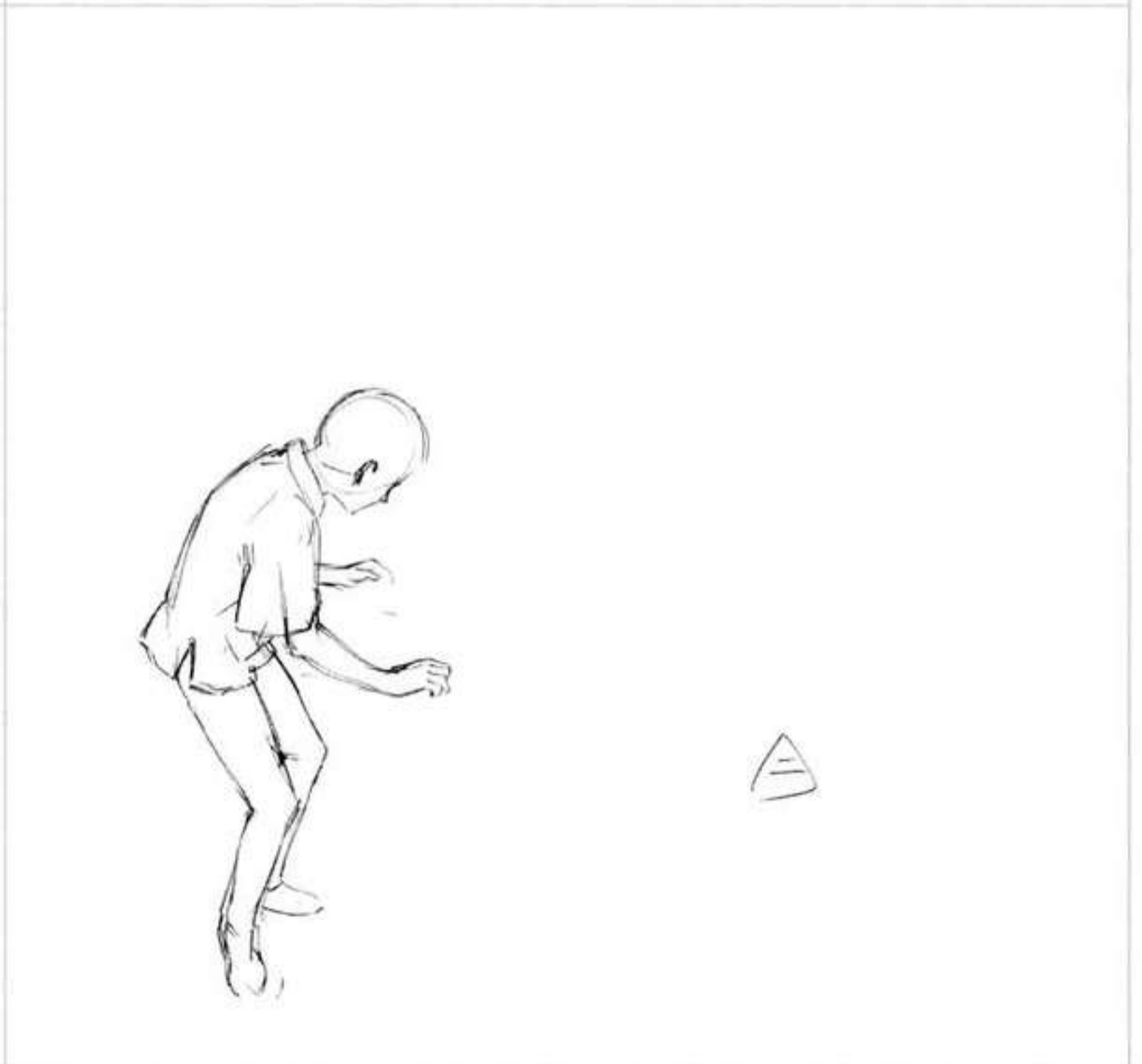
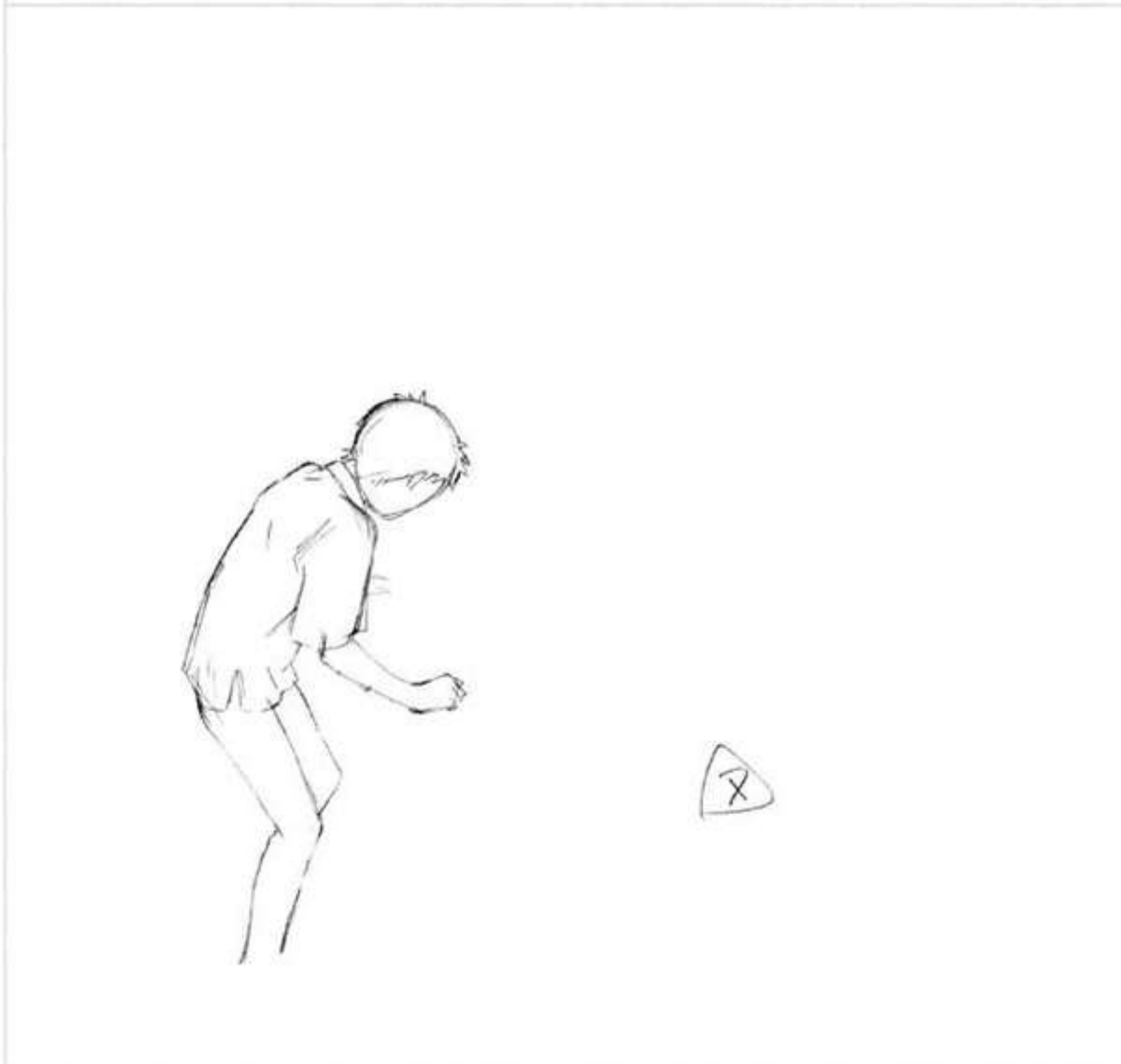
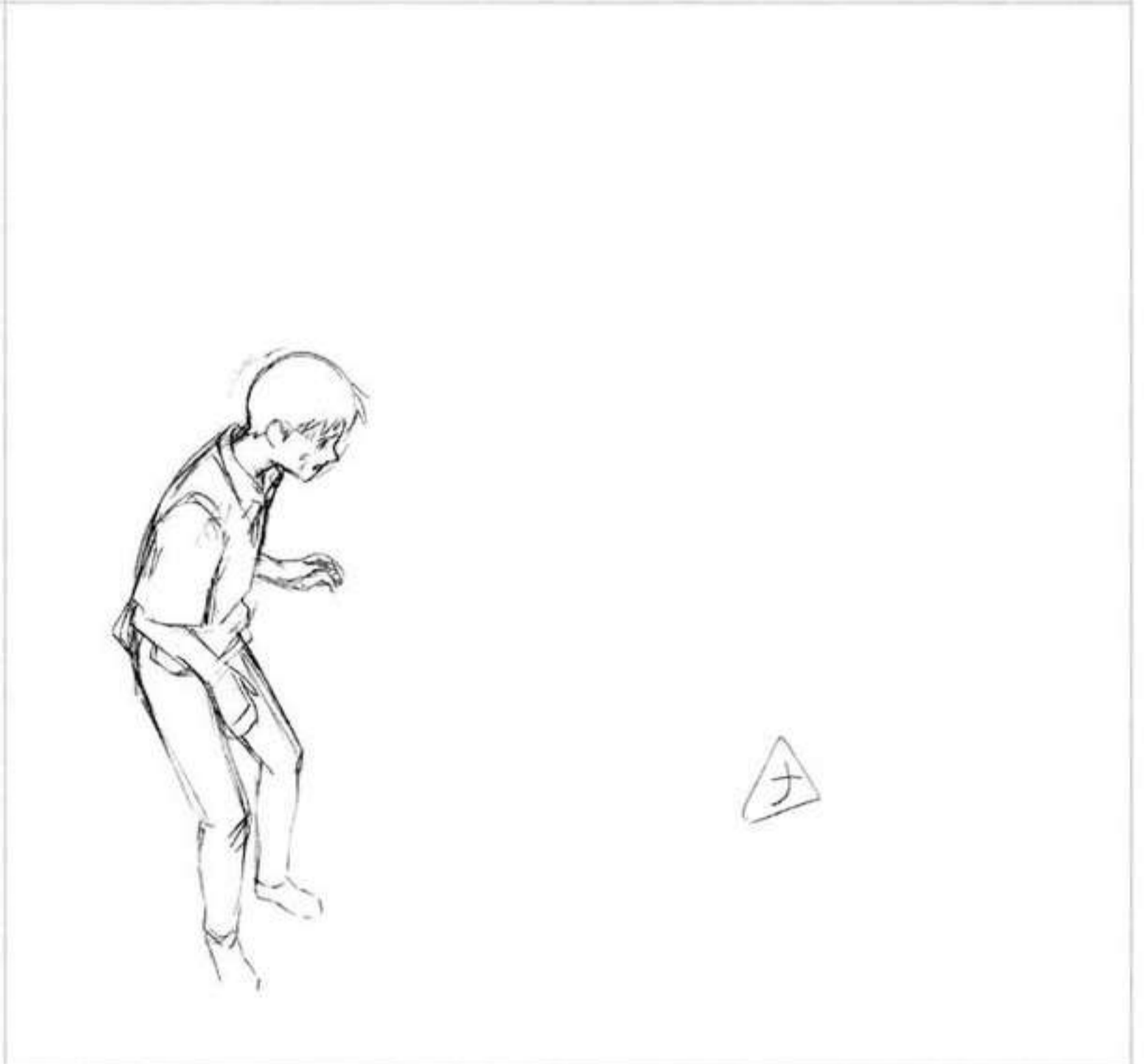
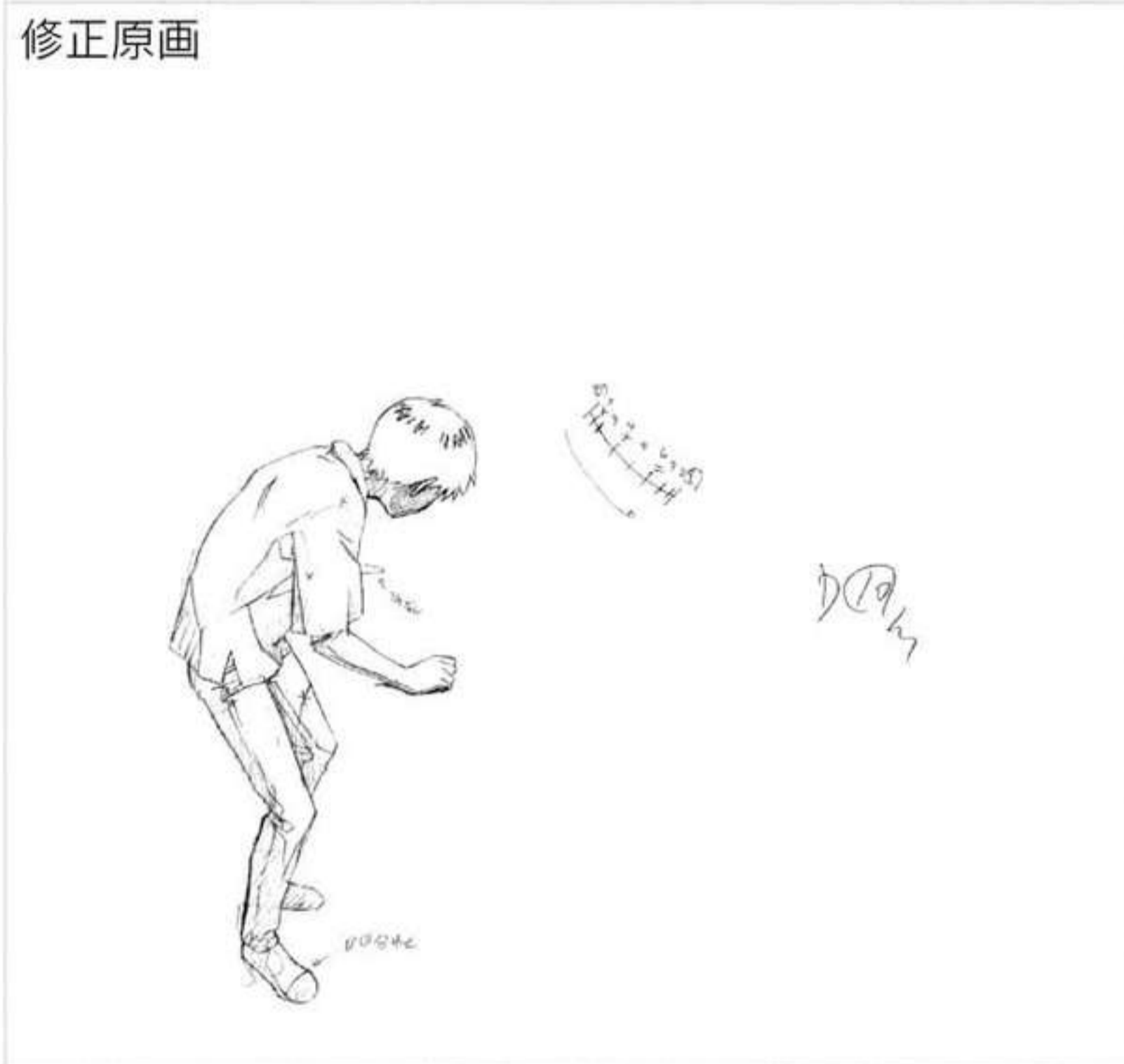

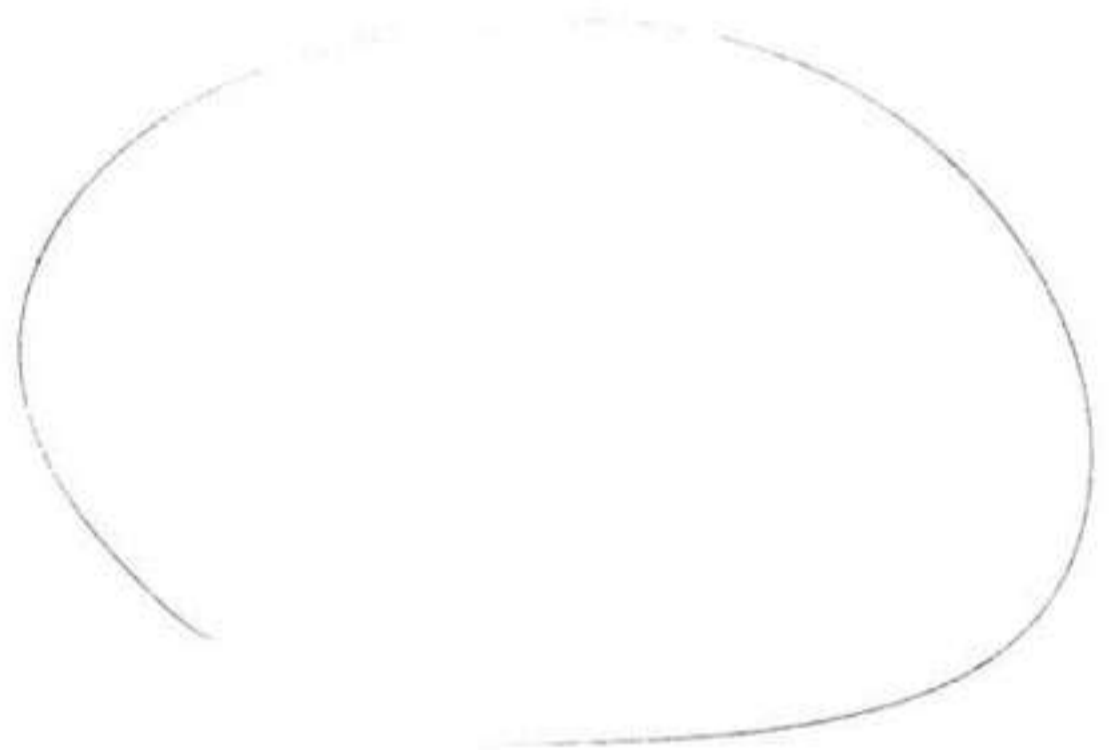
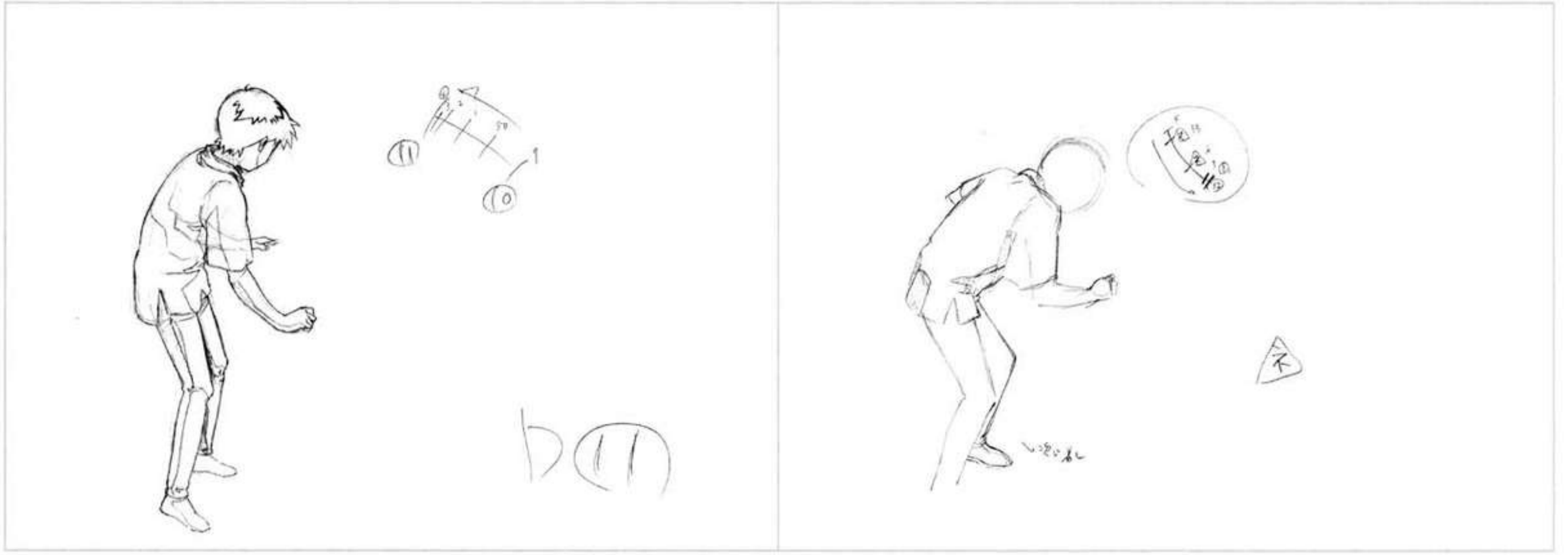

D(11) 13

修正原画



修正原画

A	B	C	D	E
1	2	3	4	5
6				
7				
8				
9				
10				
11				
12				
13				
14				
15				
16				
17				
18				
19				
20				
21				
22				
23				
24				
25				
26				
27				
28				
29				
30				
31				
32				
33				
34				
35				
36				
37				
38				
39				
40				
41				
42				
43				
44				
45				
46				
47				
48				

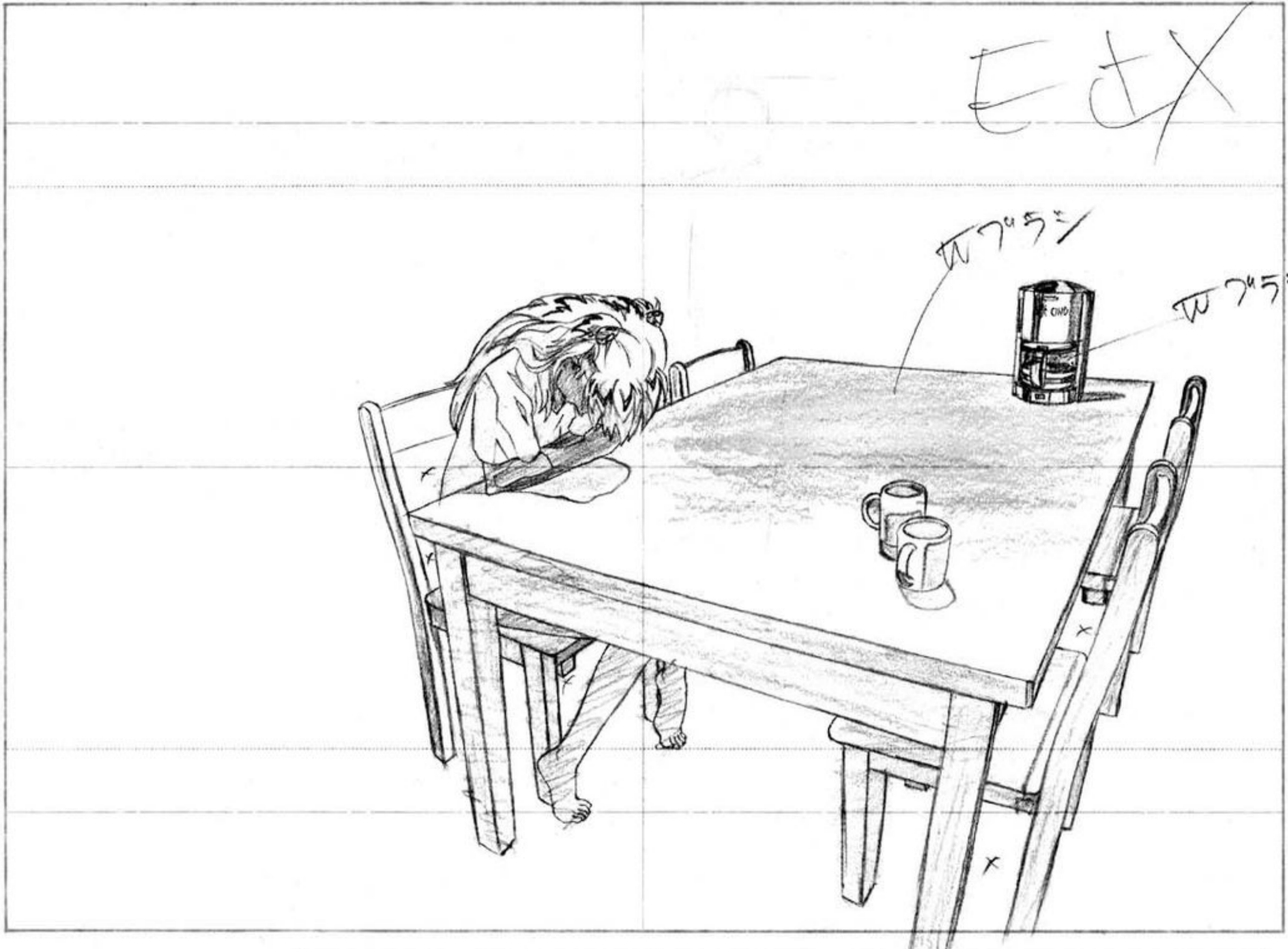

修正原画

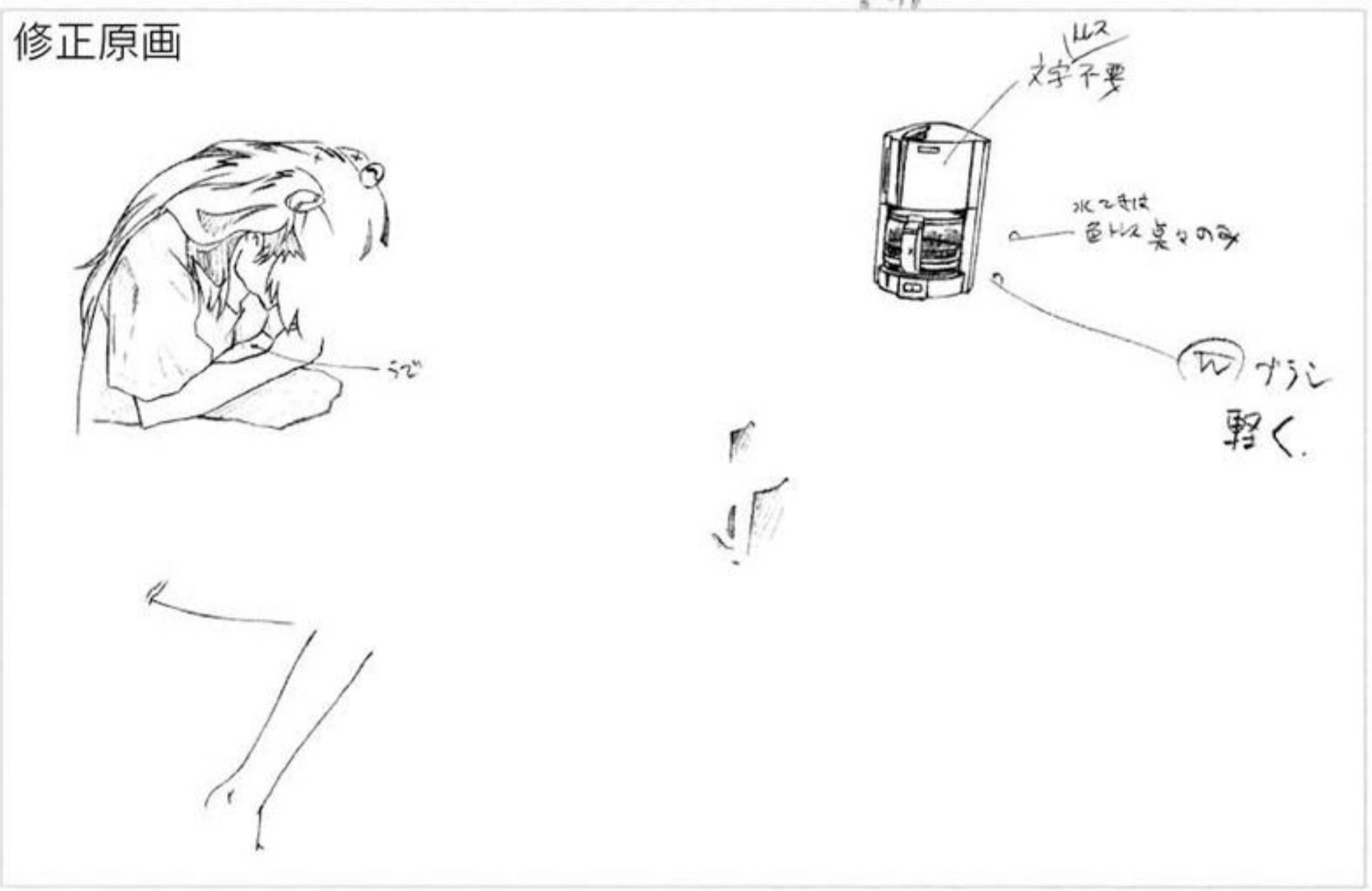

16				
17				
18				
19				
20				
21				
22				
23				
24				
25				
26				
27				
28				
29				
30				
31				
32				
33				
34				
35				
36				
37				
38				
39				
40				
41				
42				
43				
44				
45				
46				
47				
48				

☆	74	128
干	76	130
	78	132
ツ	80	134
テ	82	136
	84	138
9	86	140
ト	88	142
	90	144
	92	2
ナ	94	4
	96	6
ニ	98	8
干	100	10
	102	12
ツ	104	14
テ	106	16
	108	18
9	110	20
ト	112	22
	114	24
	116	26
ナ	118	28
	120	30
ニ	122	32
干	124	34
	126	36

	38		62		86		110		134		2		26
	40		64		88		112		136		4		28
	42		66		90		114		138		6		30
	44		68		92		116		140		8		32
	46		70		94		118		142		10		34
	48		72		96		120		144		12		36
	50		74		98		122		146		14		38
	52		76		100		124		148		16		40
	54		78		102		126		150		18		42
	56		80		104		128		152		20		
	58		82		106		130		154		22		
	60		84		108		132		156		24		

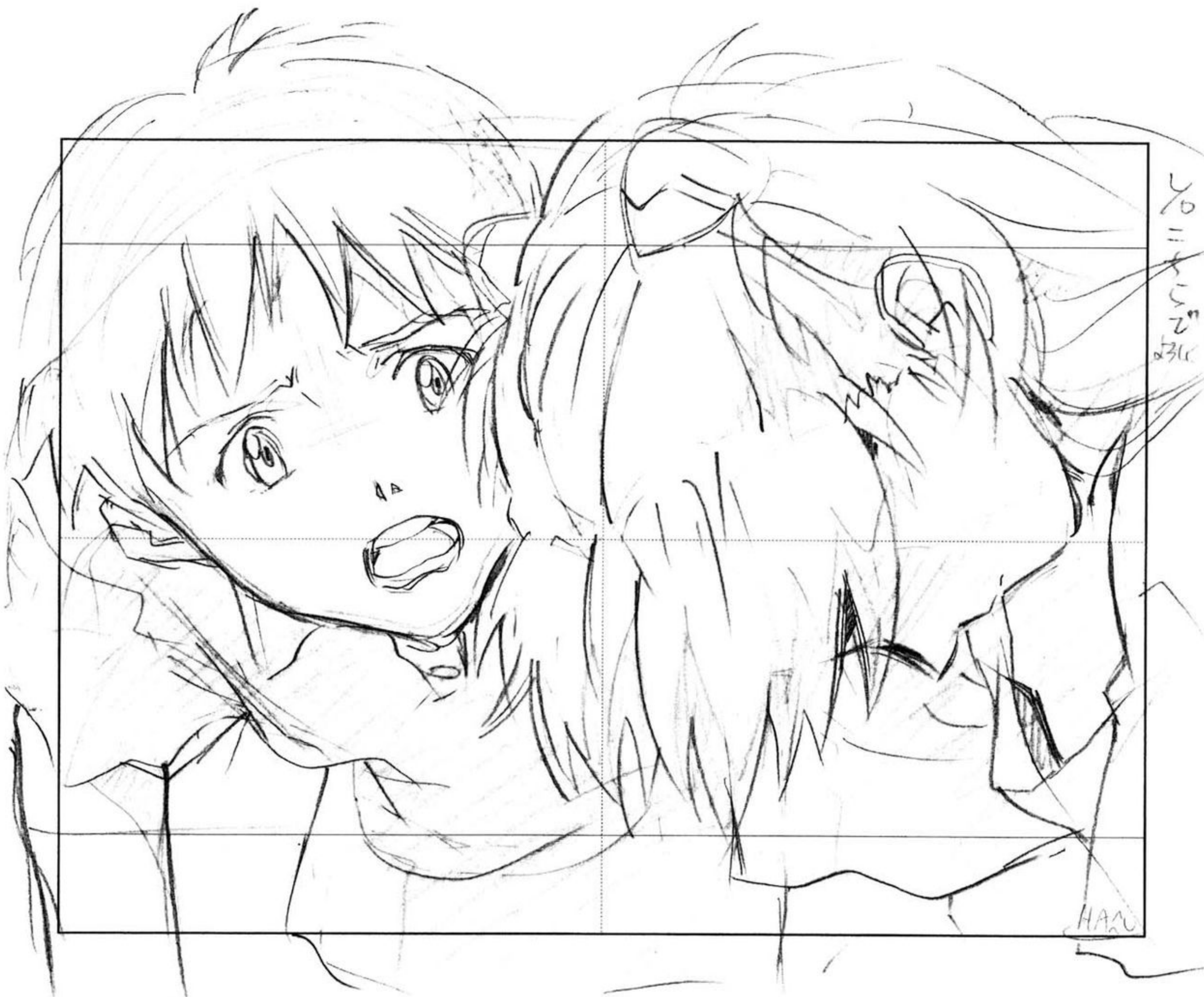

#26-C249レイアウト

#26-C249

修正原画



Fig D.Dex
1000





AEX

#26-C251

修正原画



AEX

修正原画

#26-C252

修正原画



修正原画



修正原画

修正原画



修正原画



(10) 1/3



修正原画



(11) 1/3

修正原画



修正原画



(12) 1/3

修正原画



(13) 1/3





手あき口
中間口

AA



+ 4
A(3)

①	
②	2
③	4
④	6
⑤	8
⑥	10
⑦	12
⑧	14
⑨	16
⑩	18
⑪	20
⑫	22
⑬	24
⑭	26
⑮	28
⑯	30
⑰	32
⑱	34
⑳	36

タイムシート



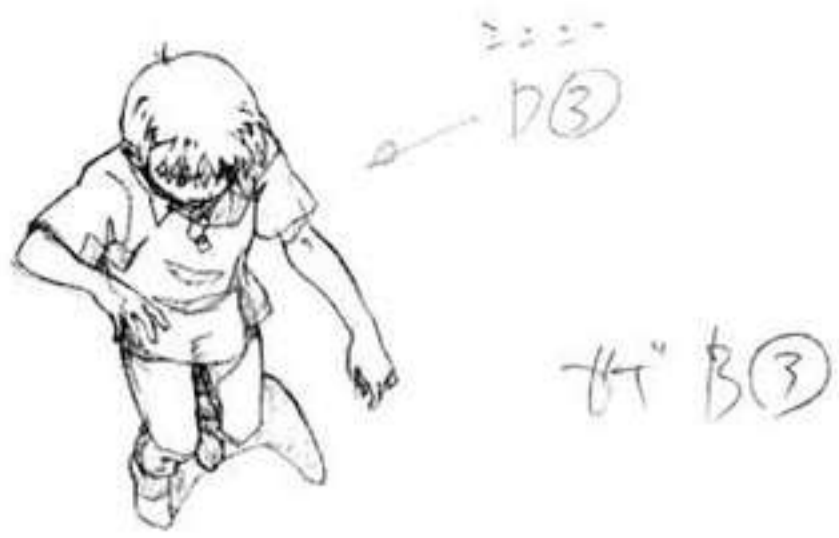

修正

修正原画

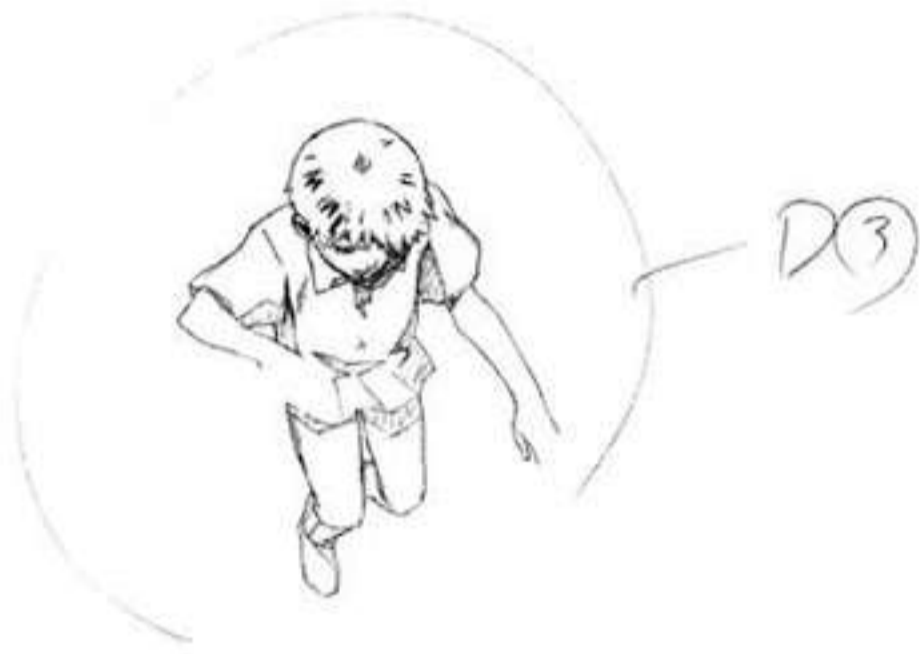

X

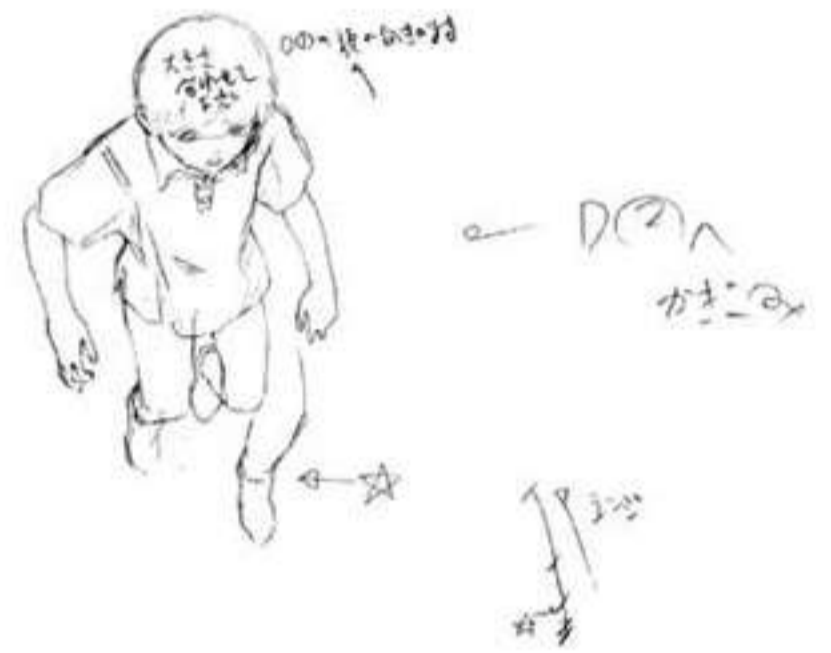
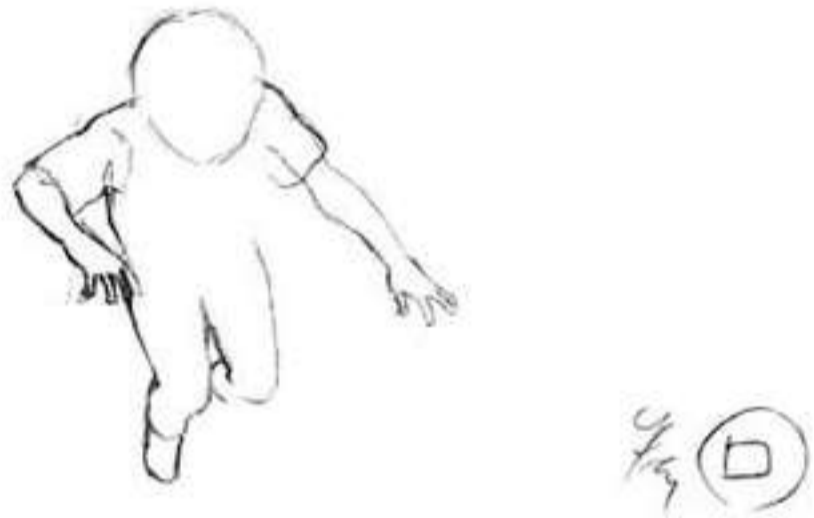

修正原画

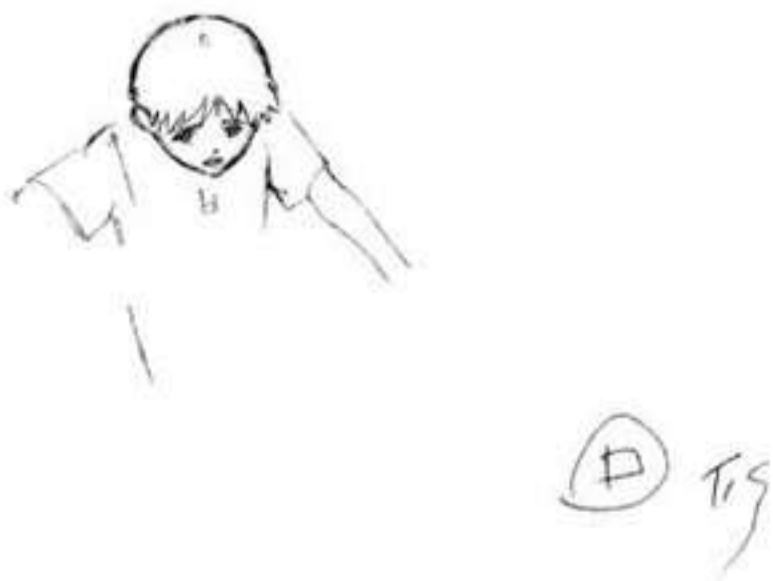

修正原画





左足
中前下落地

①

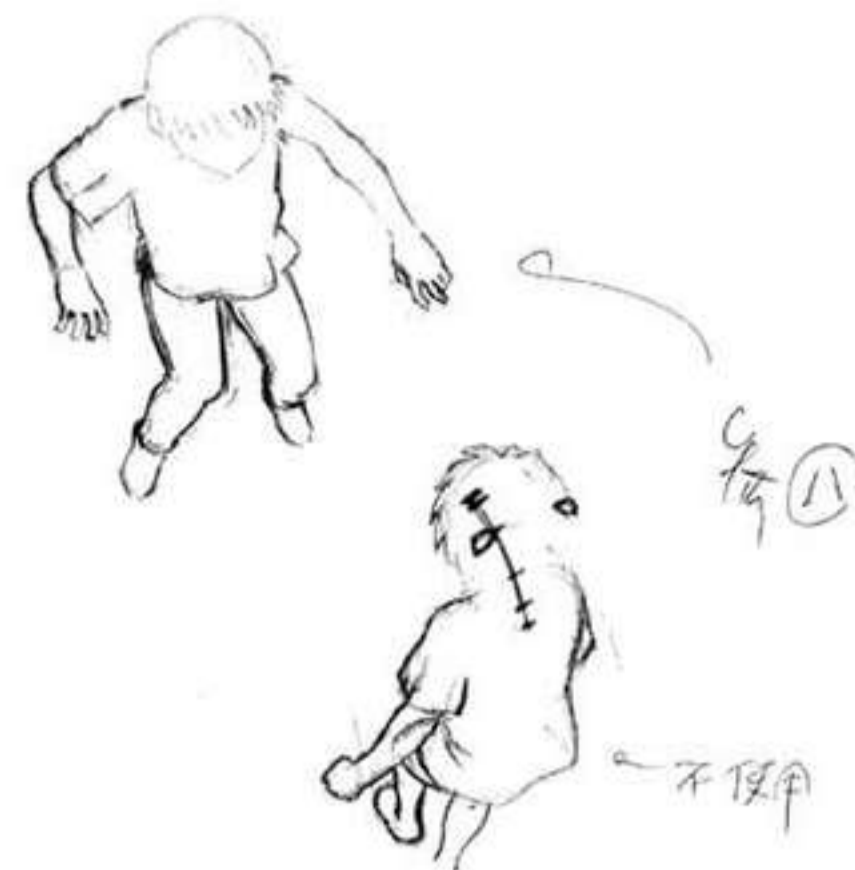

不便

①



手

D(6)



D(4)

修正原画



左足
3根
体=2.180寸

修正原画

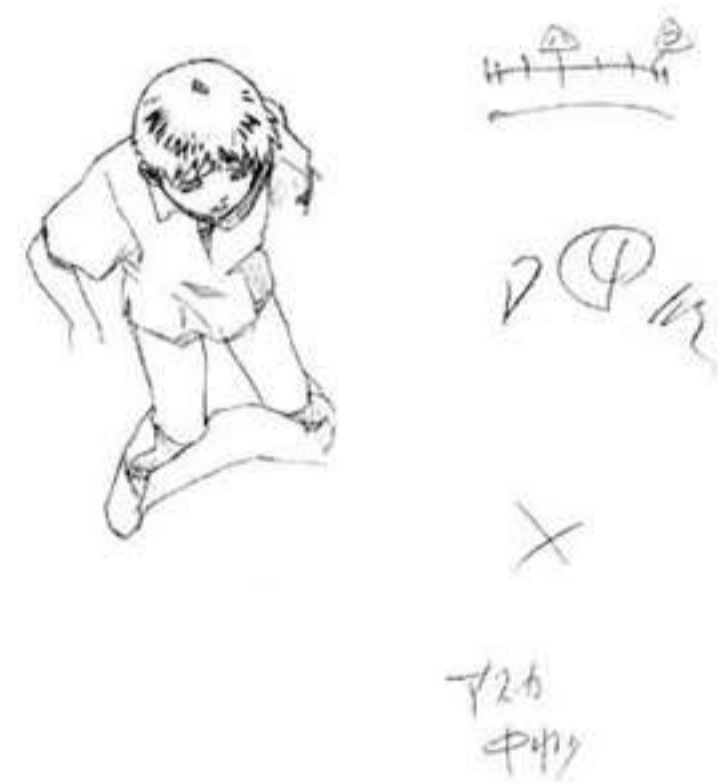

X

T26

木

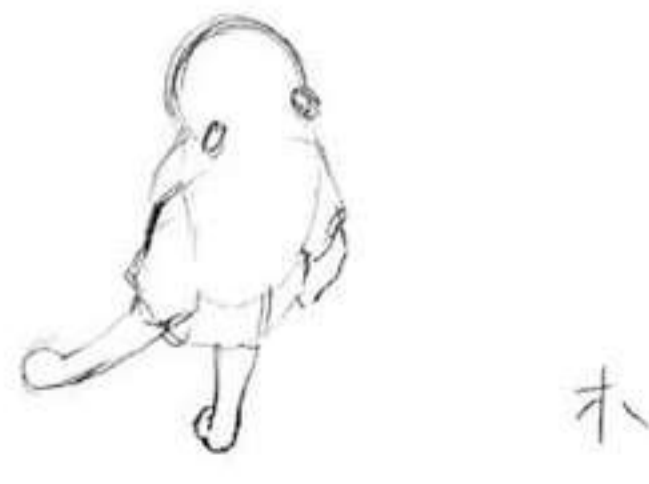

木



P47

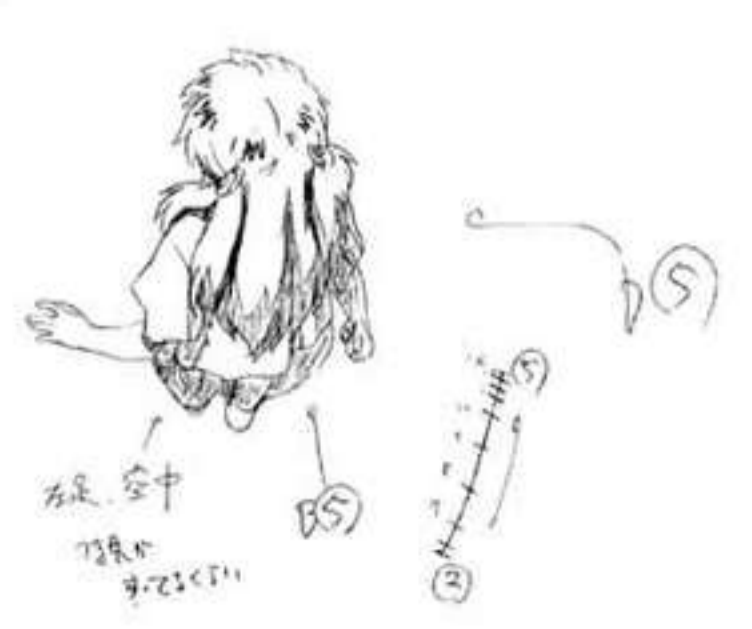

左足
空中
2.22寸

修正原画

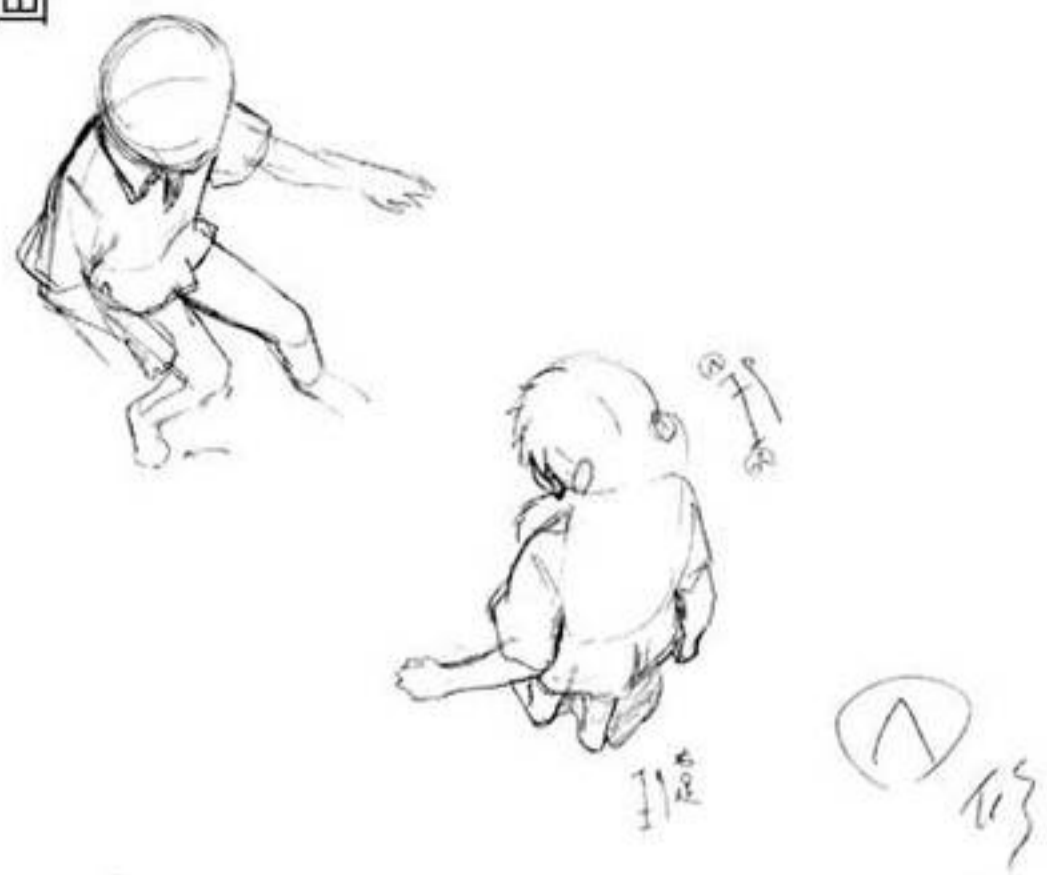

A	B	C	D	
1	1	1	1	2
1	1	1	1	4
				6
				8
				10
				12
(2)	(2)			14
				16
				18
(3)	(3)			20
				22
				24
				26
				28
				30
				32
				34
				36
(4)	(4)			38
(5)	(5)			40
				42
				44
				46
				48
				50
				52
				54
(6)	(6)			56
				58
				60
				62
				64
				66
				68
				70
				72
(7)	(7)			74
				76

タイムシート



修正原画

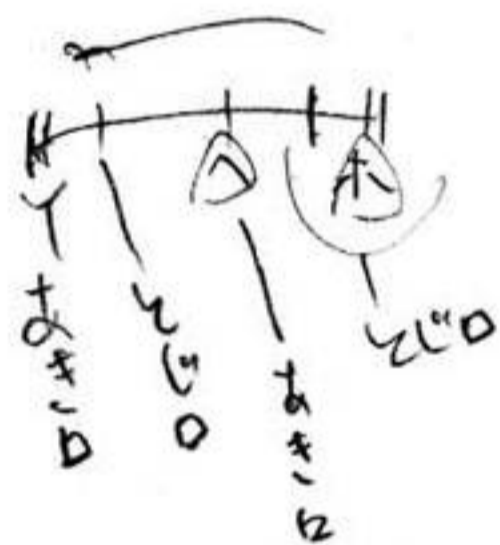

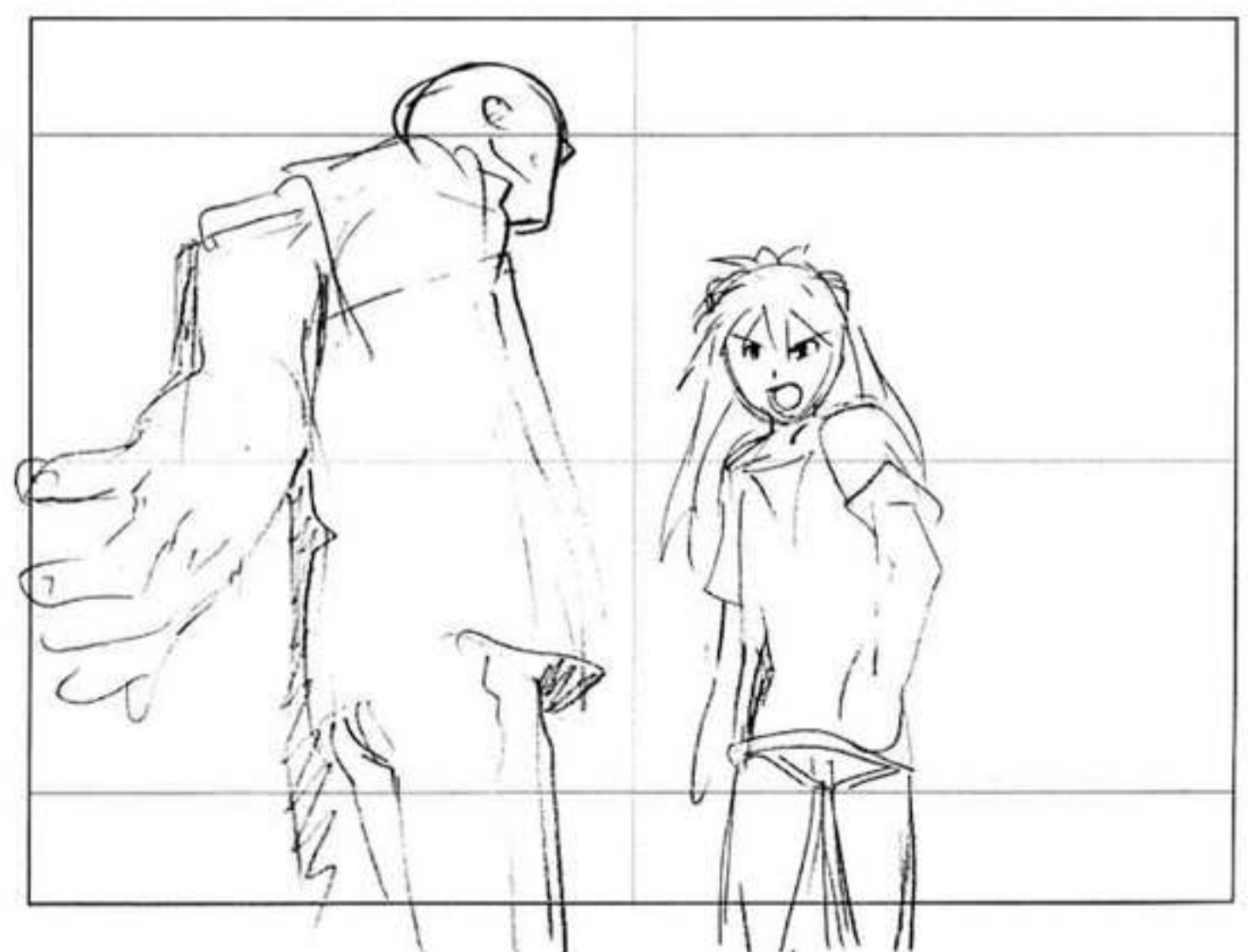
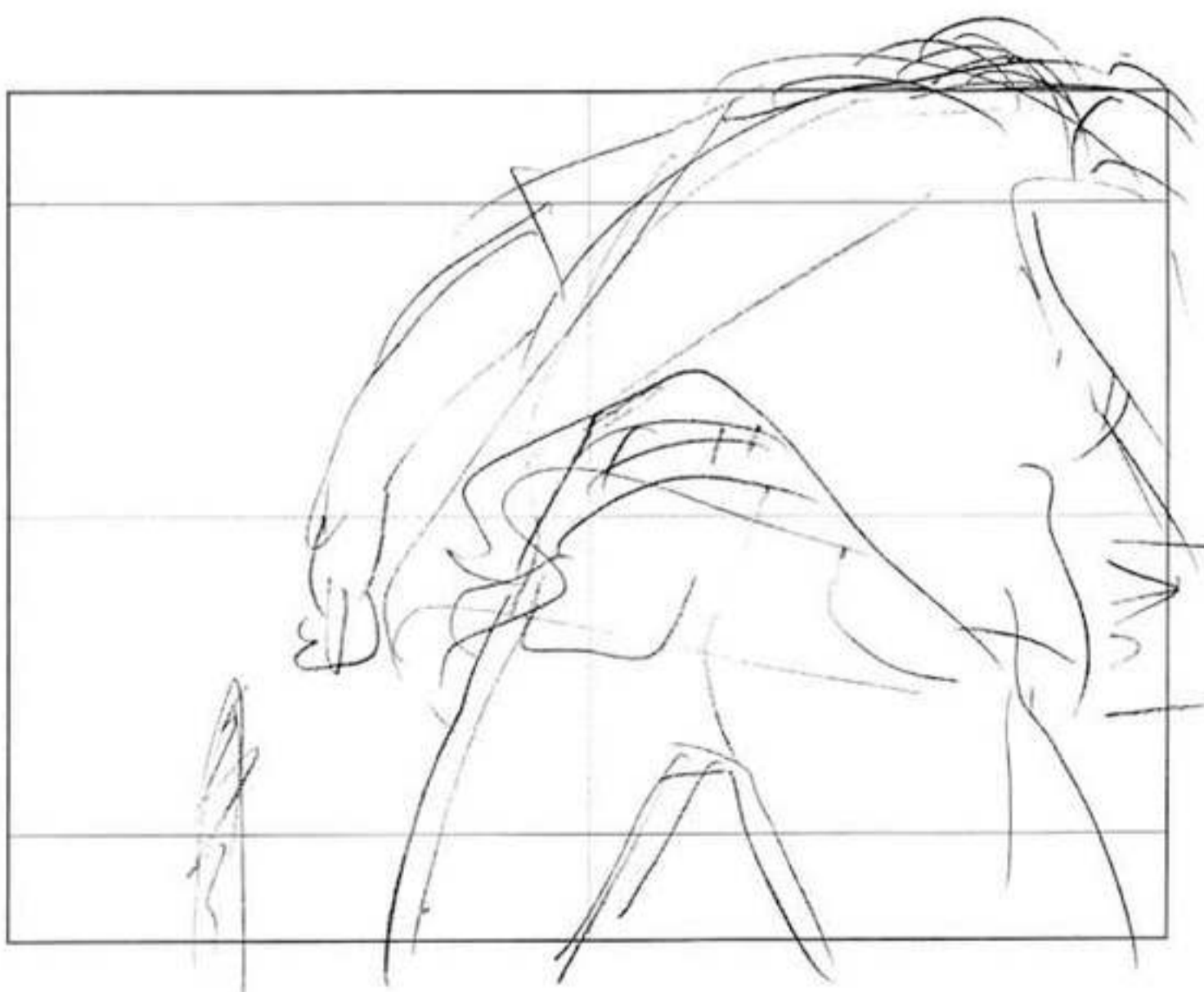
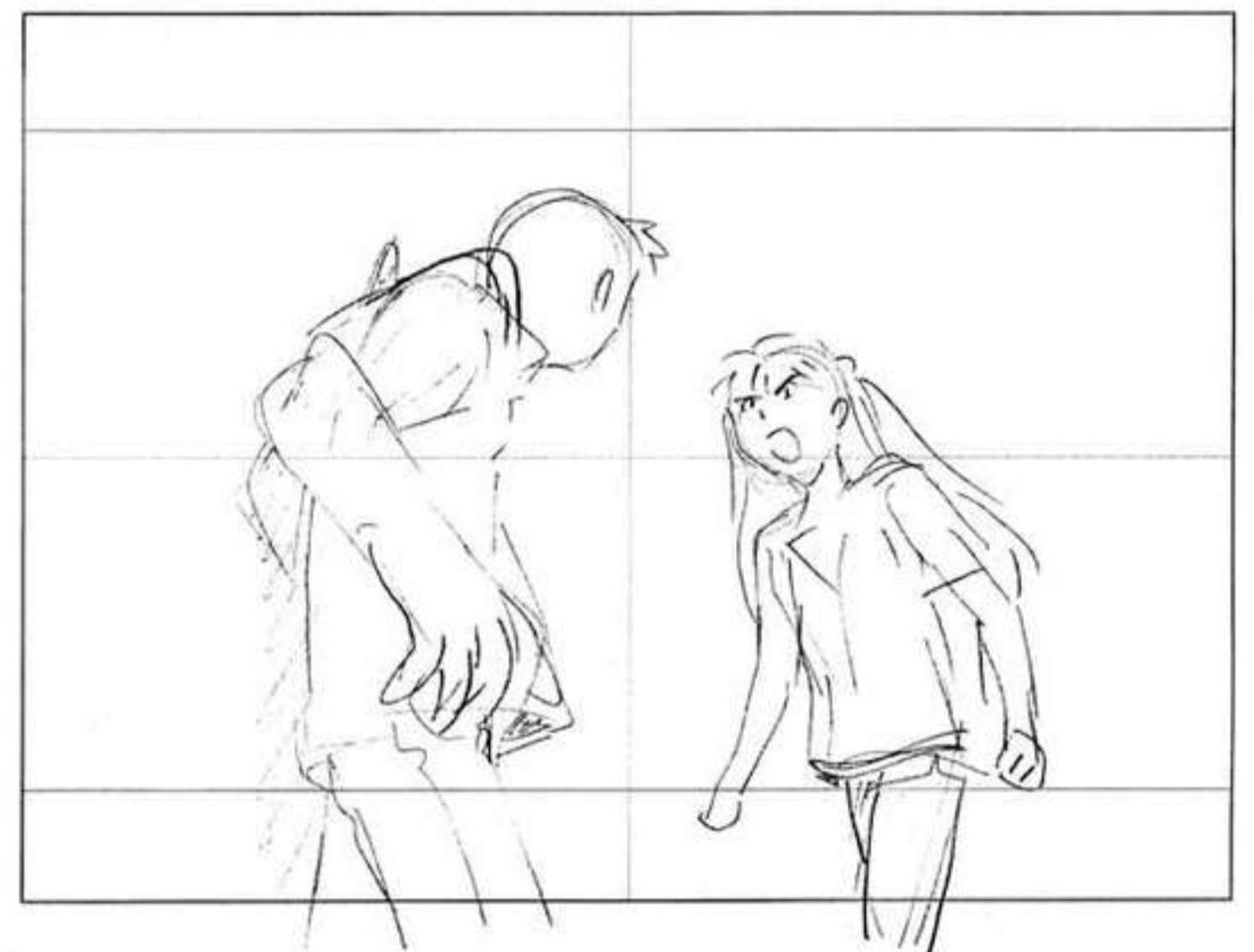
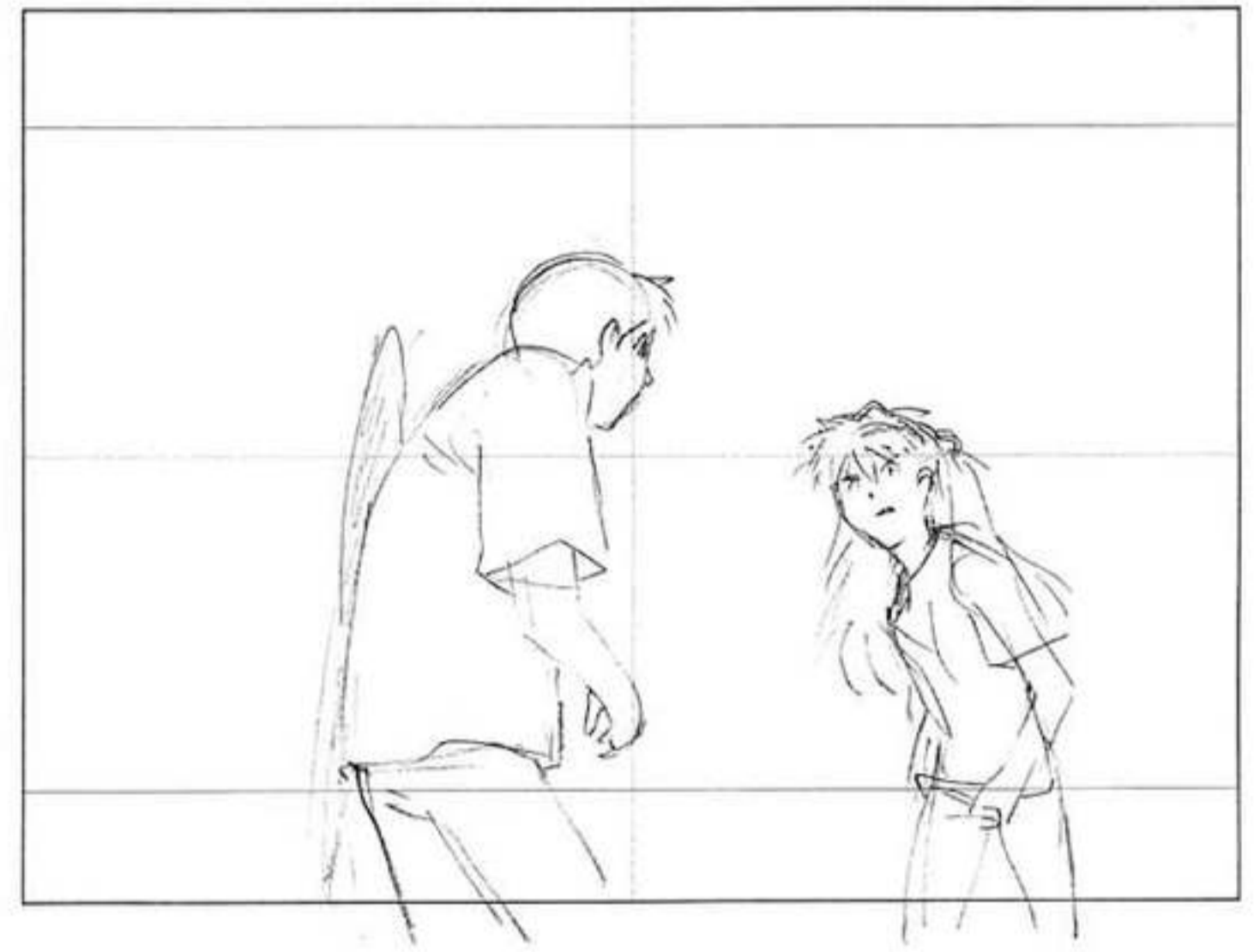
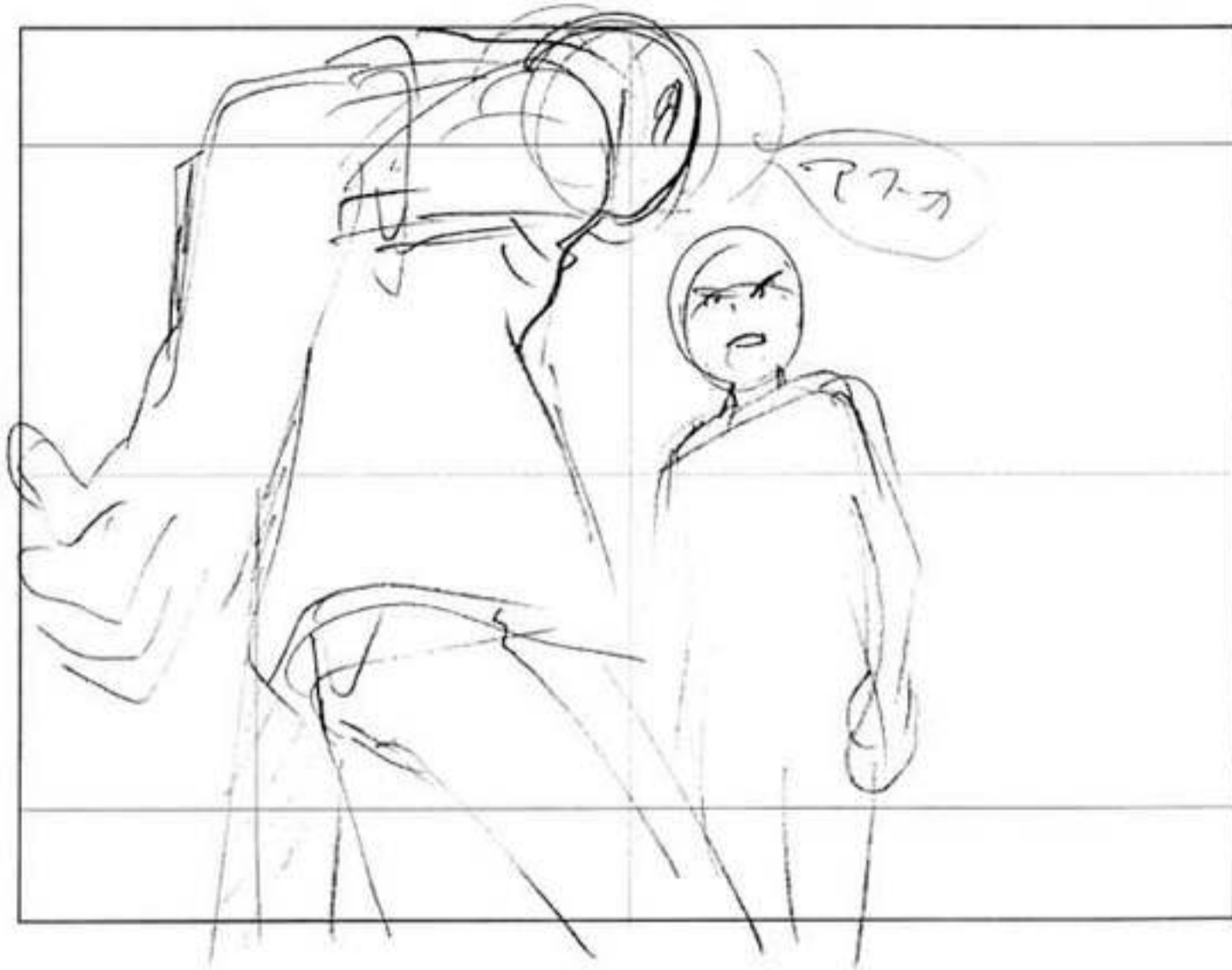



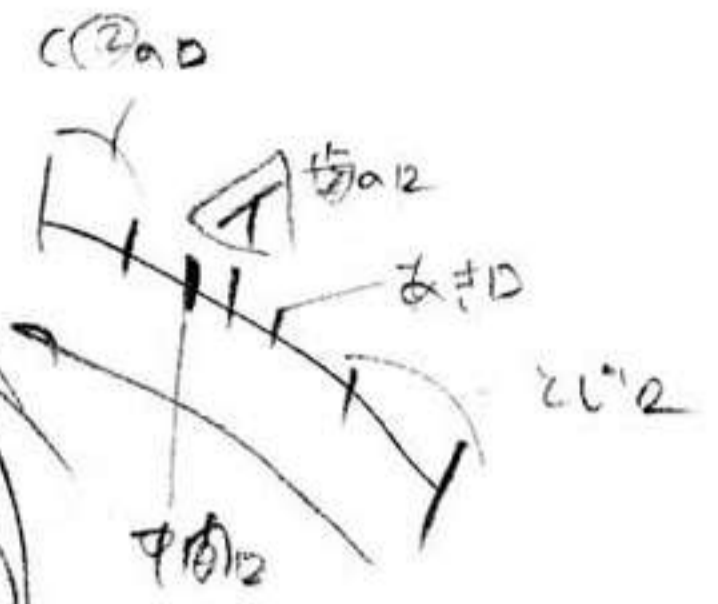

(2) 1/2



(1) 1/2 a 2



(1) 1/2



(3)
3

(3)の
色線等
巻物用に



2222
H
I

アスカ
+ 2
+ 2
+ 2
+ 2

(4)
3



A	B	C	
(E)	(D)	(C)	2
Y	-	-	4
-	-	-	6
-	-	-	8
<A	-	-	10
-	-	-	12
-	-	-	14
<O	-	-	16
-	-	-	18
(E)	(E)	-	20
-	-	-	22
-	-	-	24
(B)	(Y)	-	26
(A)	=	-	28
-	-	-	30
-	-	-	32
-	-	-	34
-	-	-	36
(E)	(E)	-	38
-	-	-	40
-	-	-	42
-	-	-	44
(B)	(E)	-	46
-	-	-	48
-	ホ	-	50
-	ハ	-	52
(A)	(E)	-	54
-	-	-	56
(X)	(E)	-	58

タイムシート

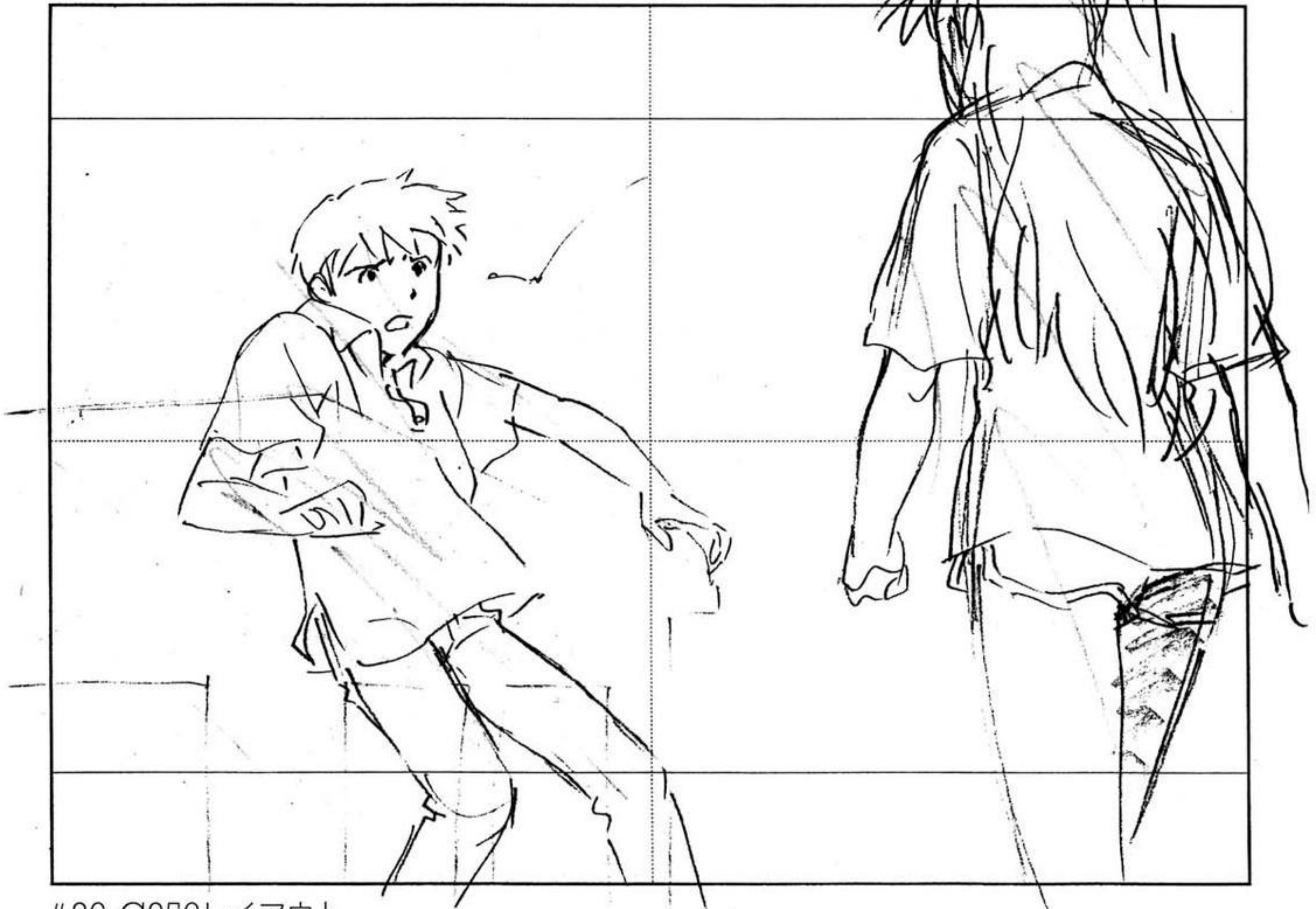

#26-C256レイアウト

#26-C256



修正原画

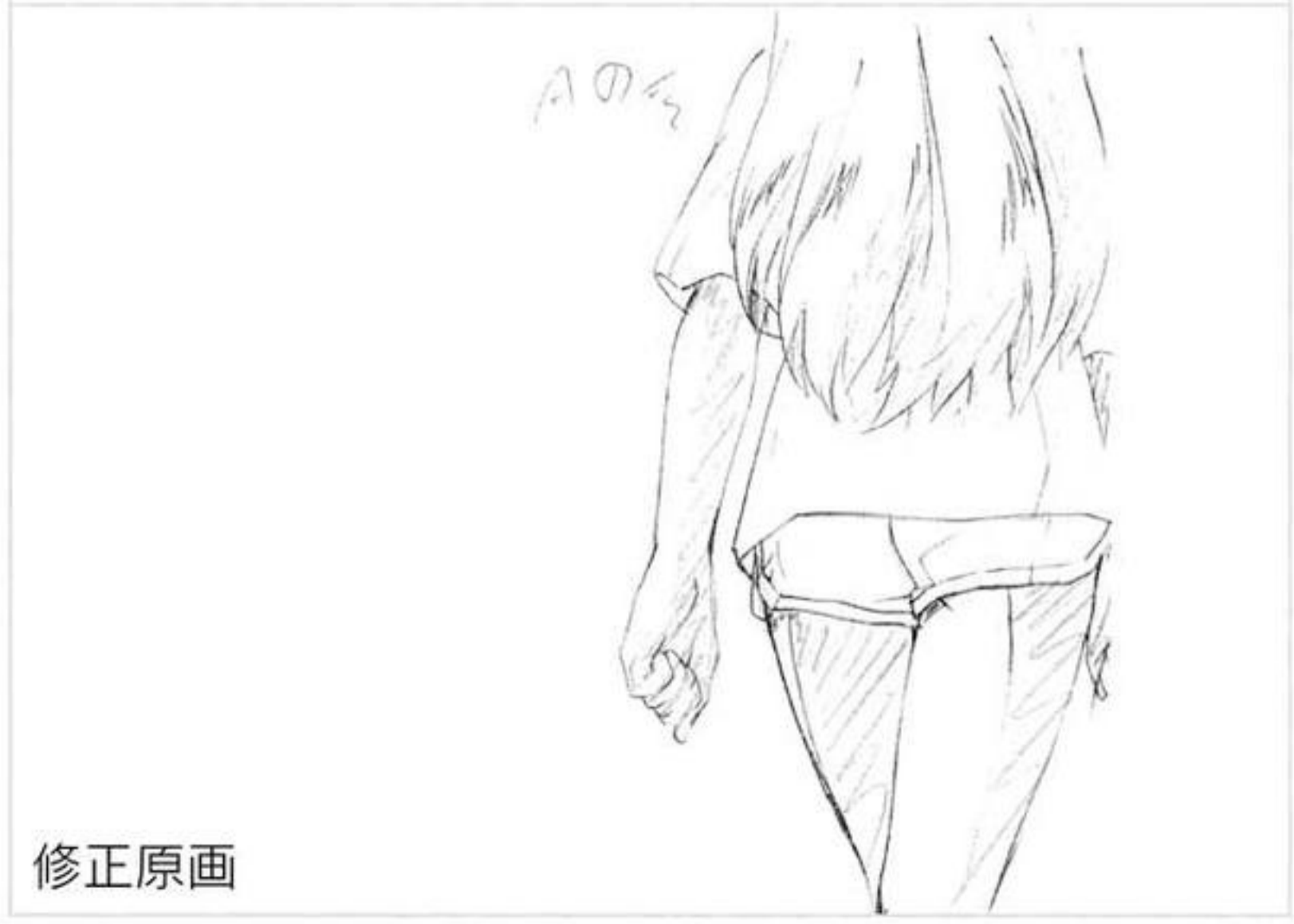

修正原画

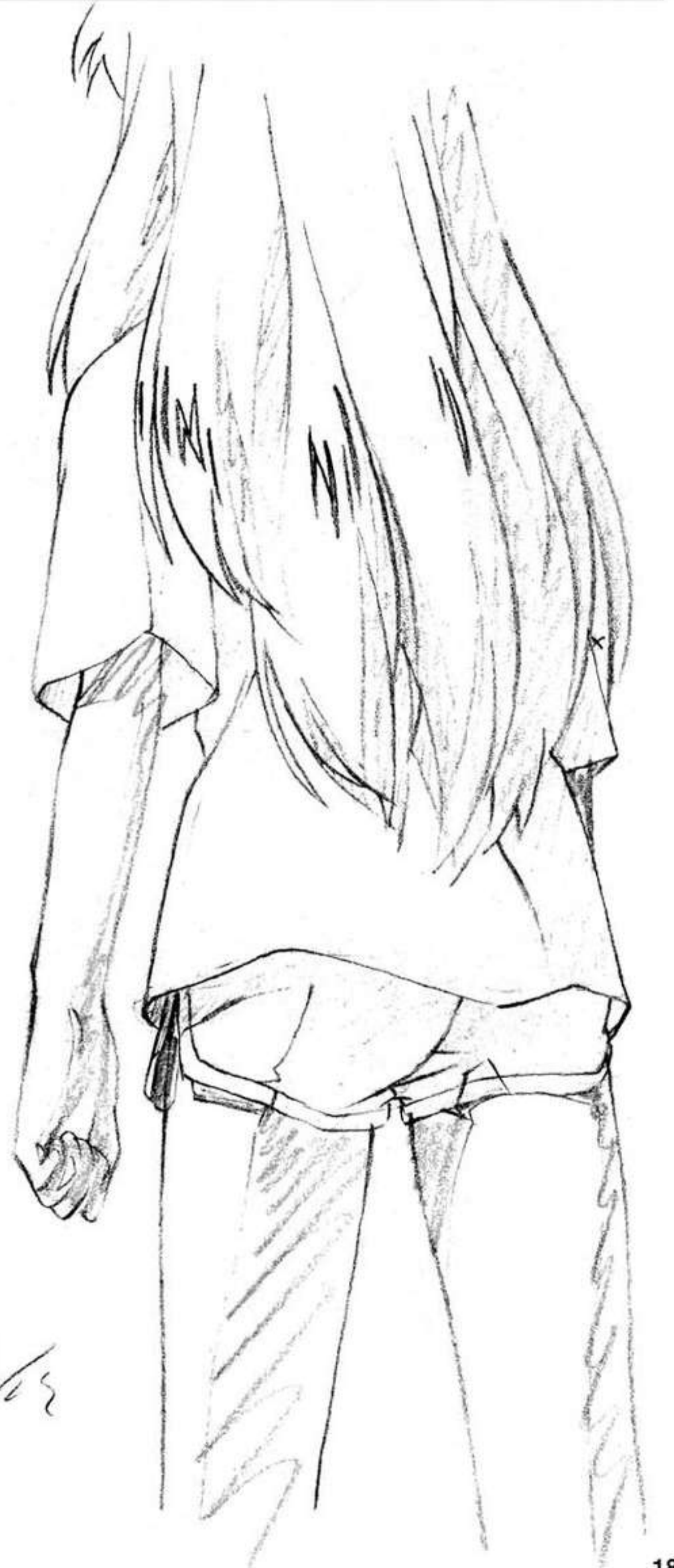

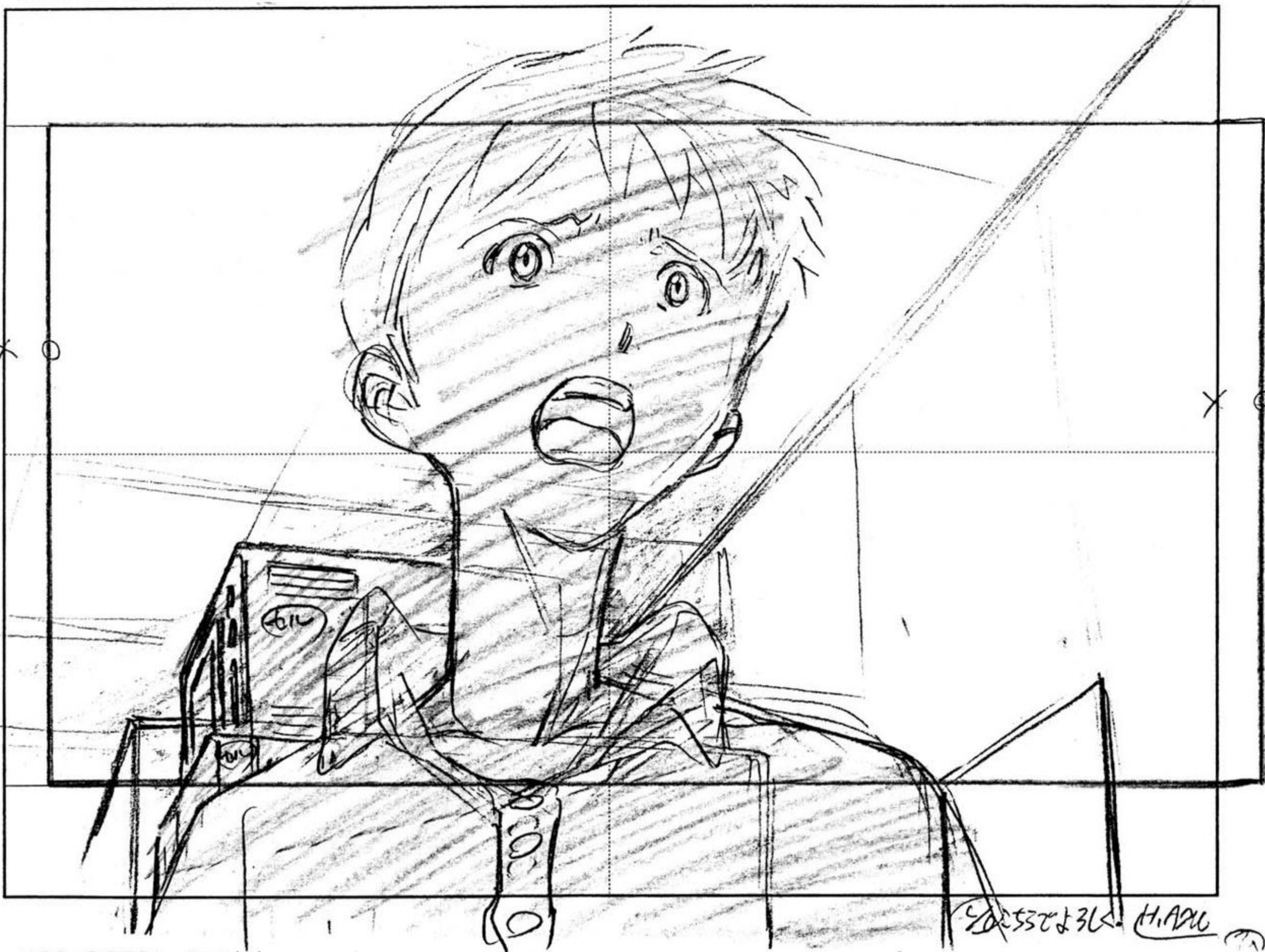

202537と3L H.ADU

#26-C258レイアウト



Bの



おたけの
おたけの

☆

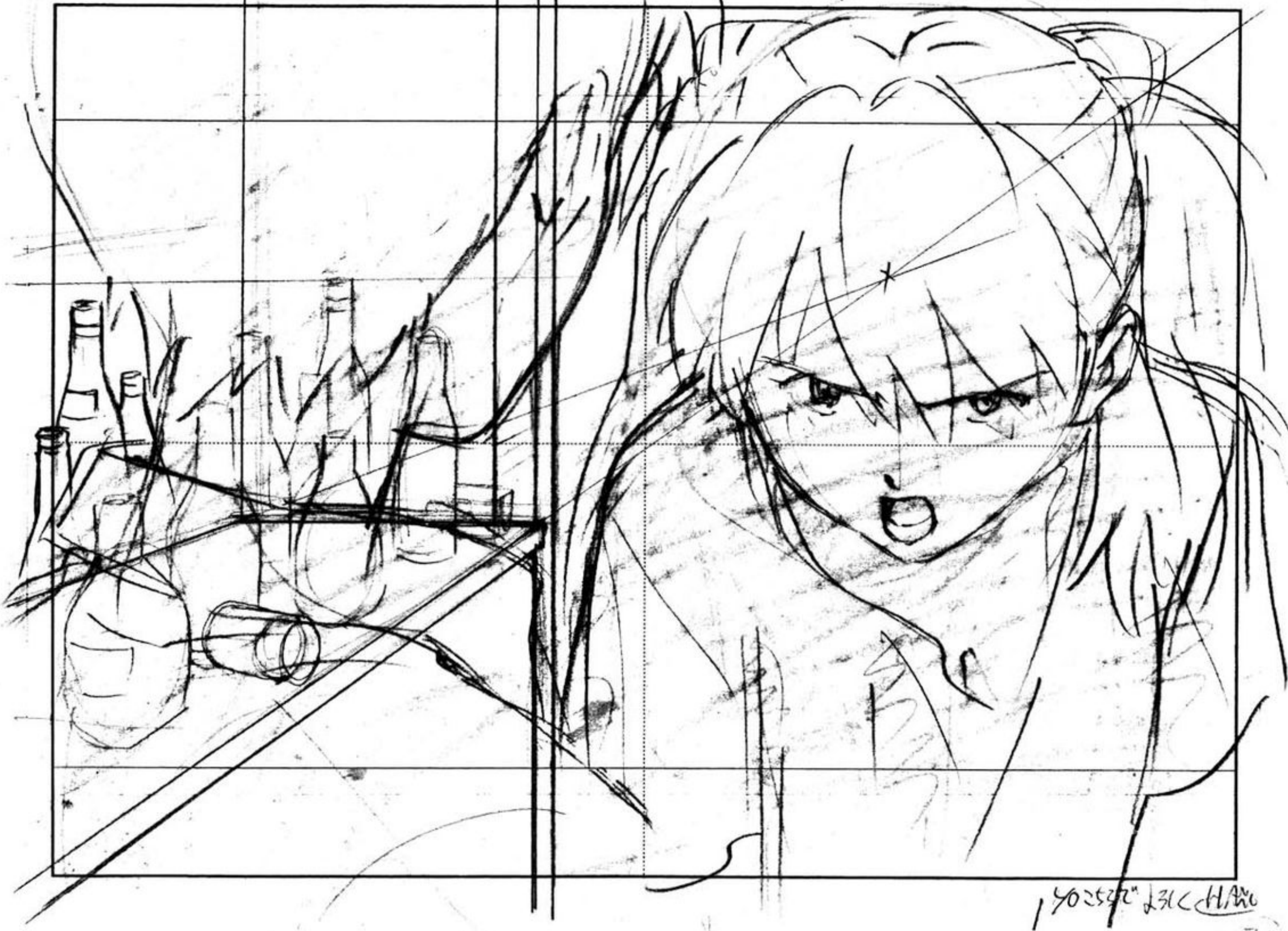

1/30 2597 231C H/A 2000



A01/03





A	
1	
2	
3	
4	
5	
6	
7	
8	
9	
10	
11	
12	
13	
14	
15	
16	
17	
18	
19	
20	
21	
22	
23	
24	
25	
26	
27	
28	
29	
30	

タイムシート





A(1)
13



A(3)
13

A(2) 13



A(7)
1/3



A(7)
1/3

#26-C266レイアウト

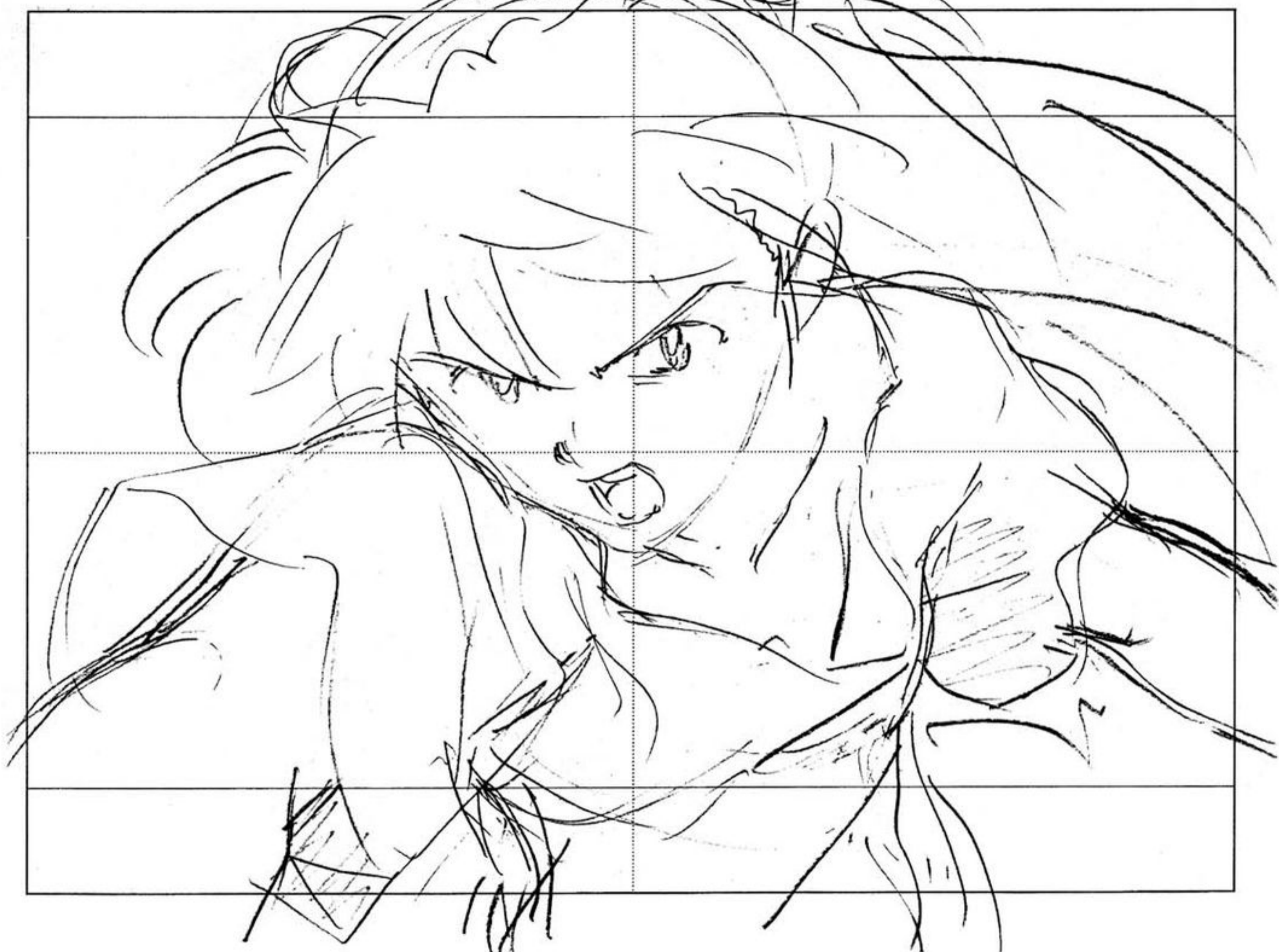

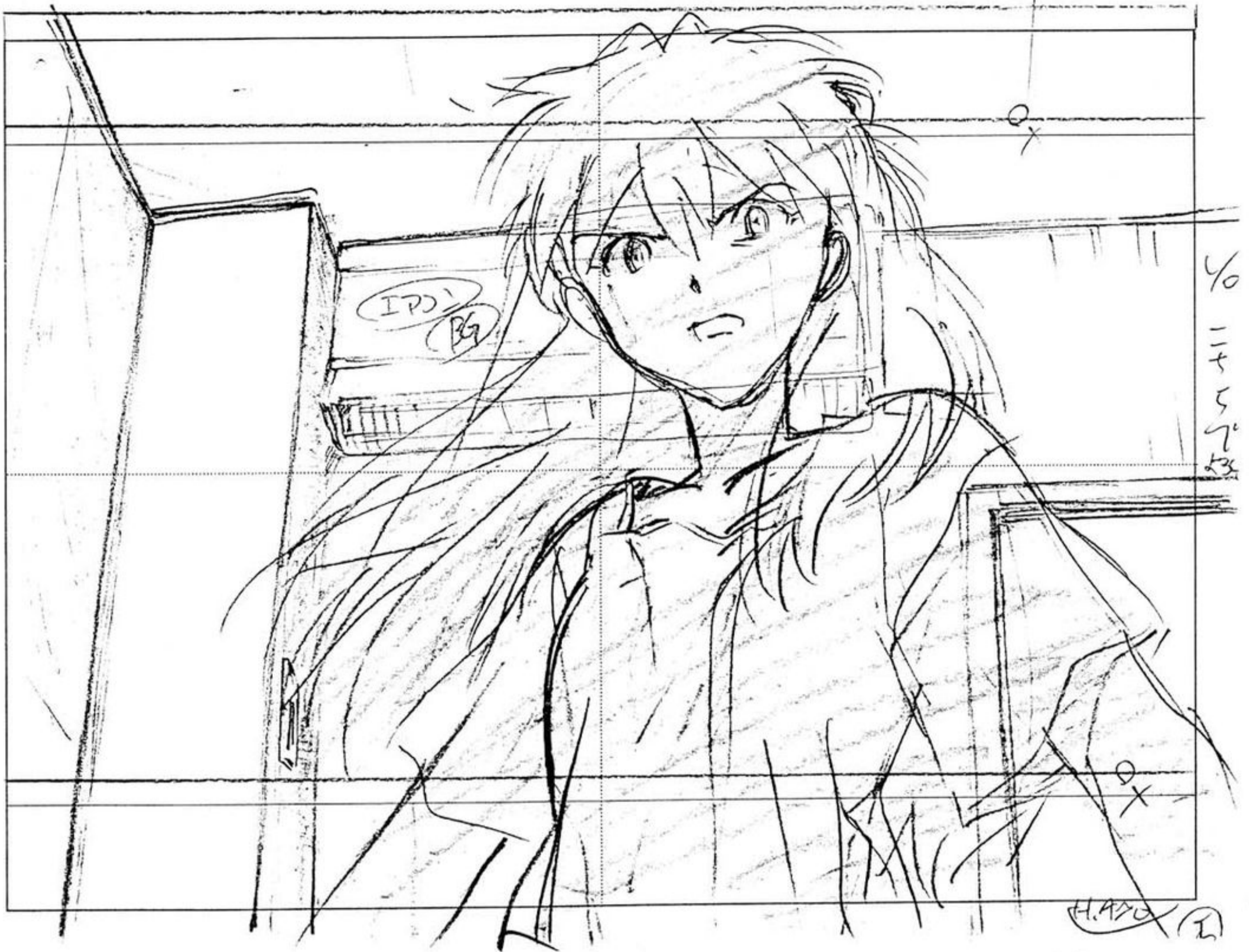

#26-C268,270レイアウト

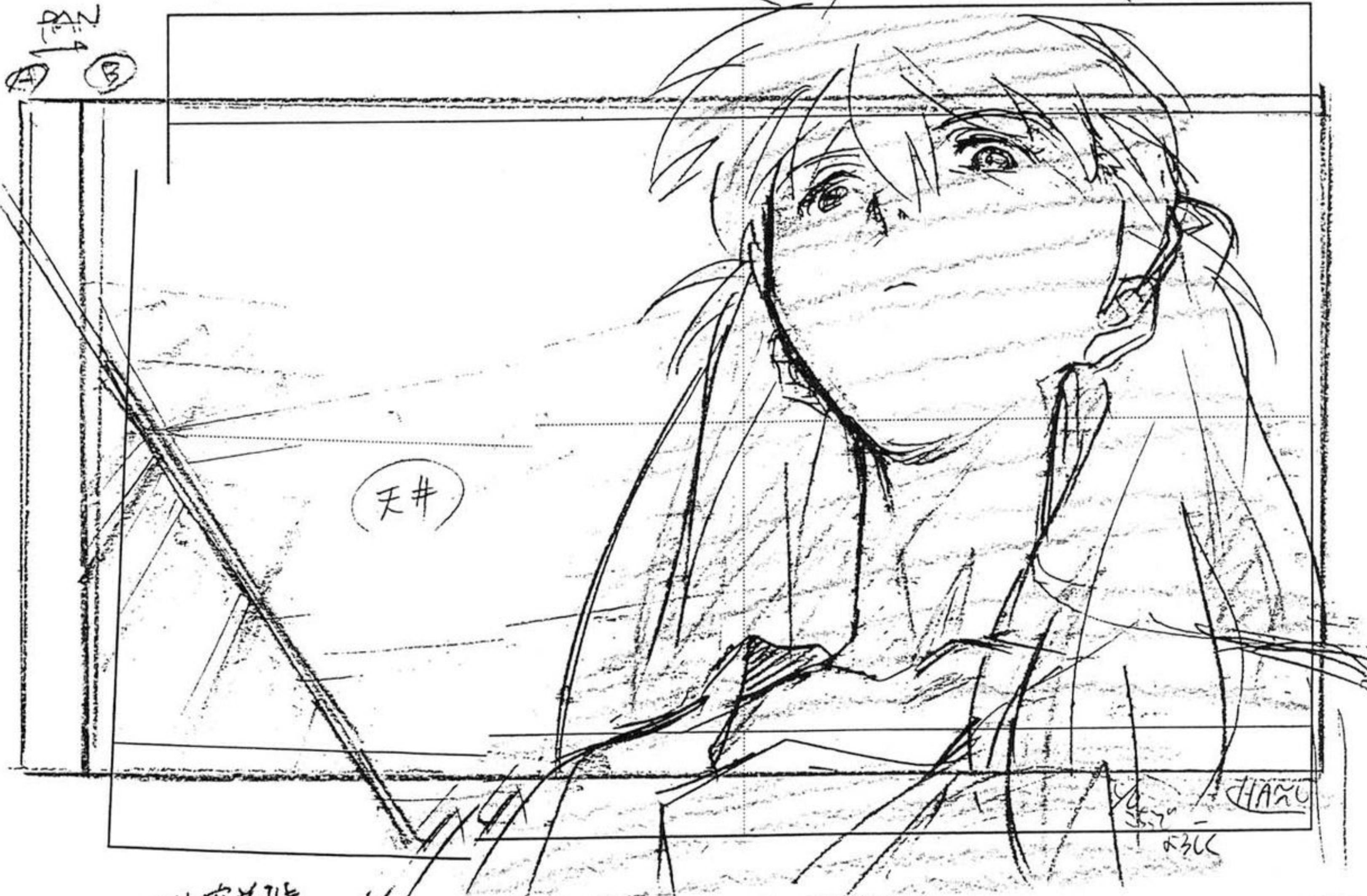

天井着陸.

PAN中. この部分(天井着陸)

2

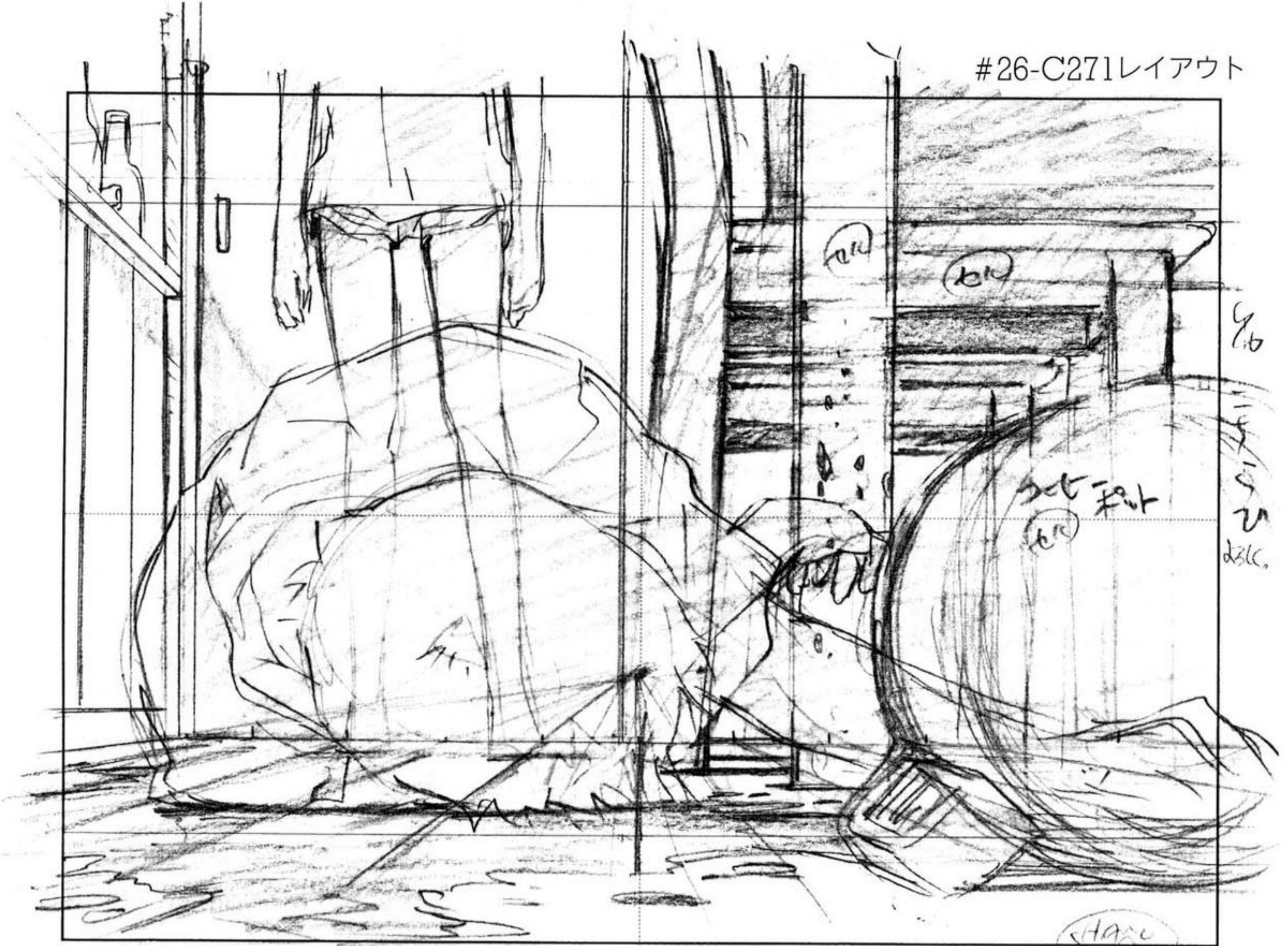

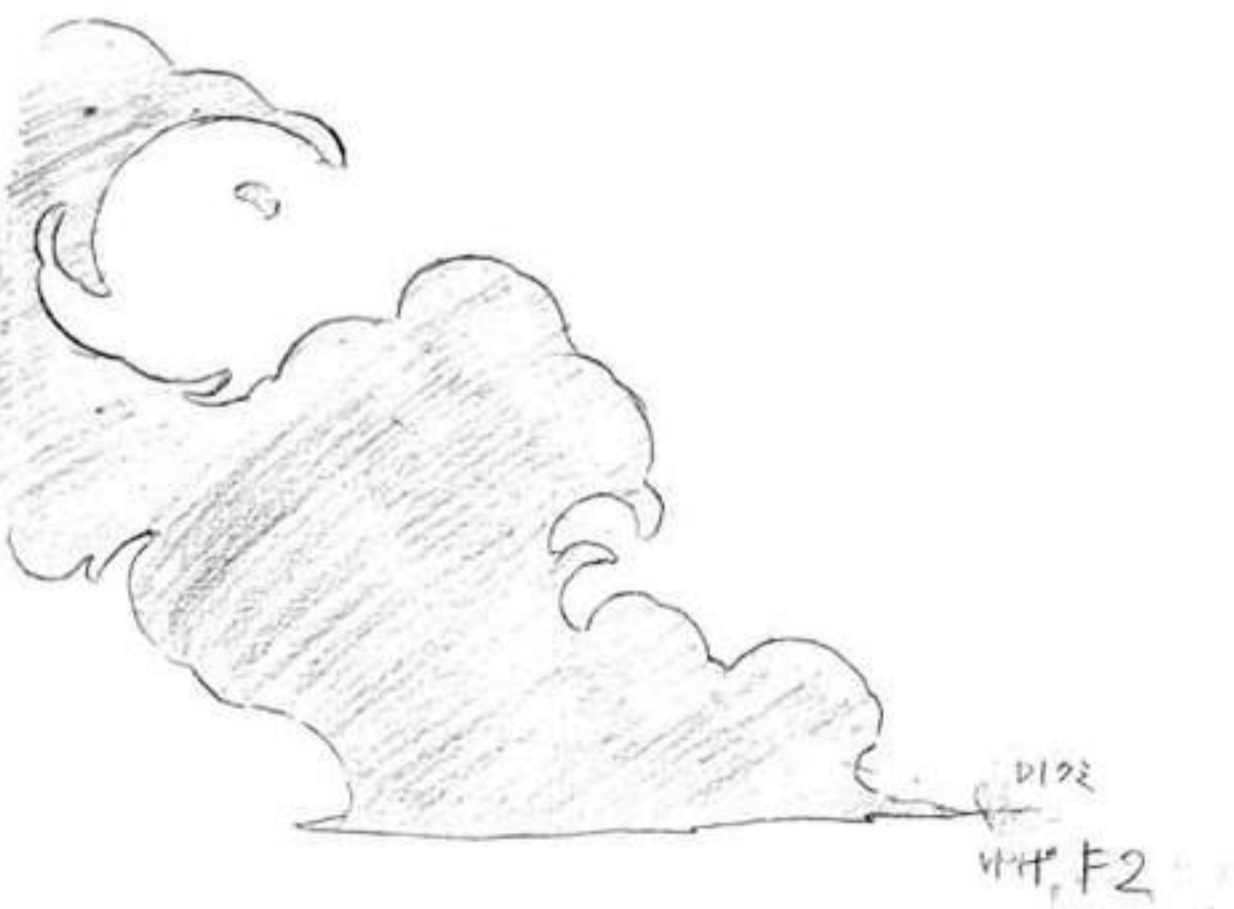
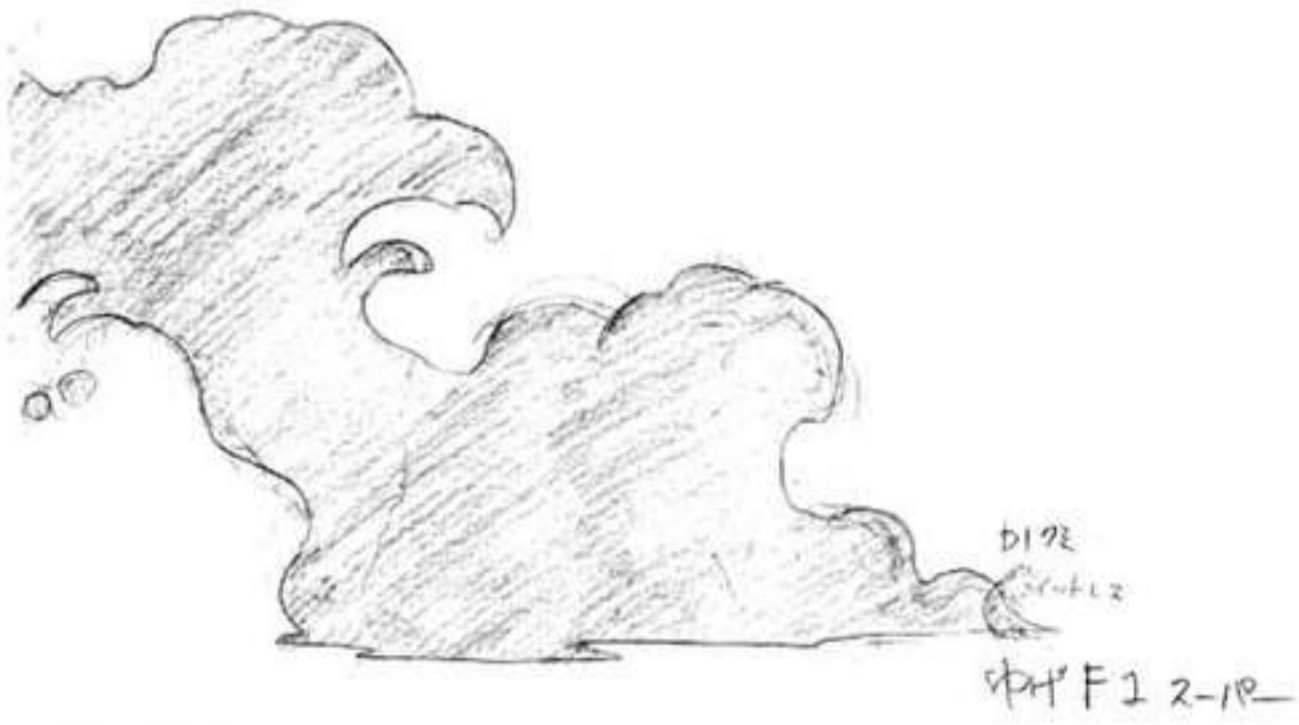
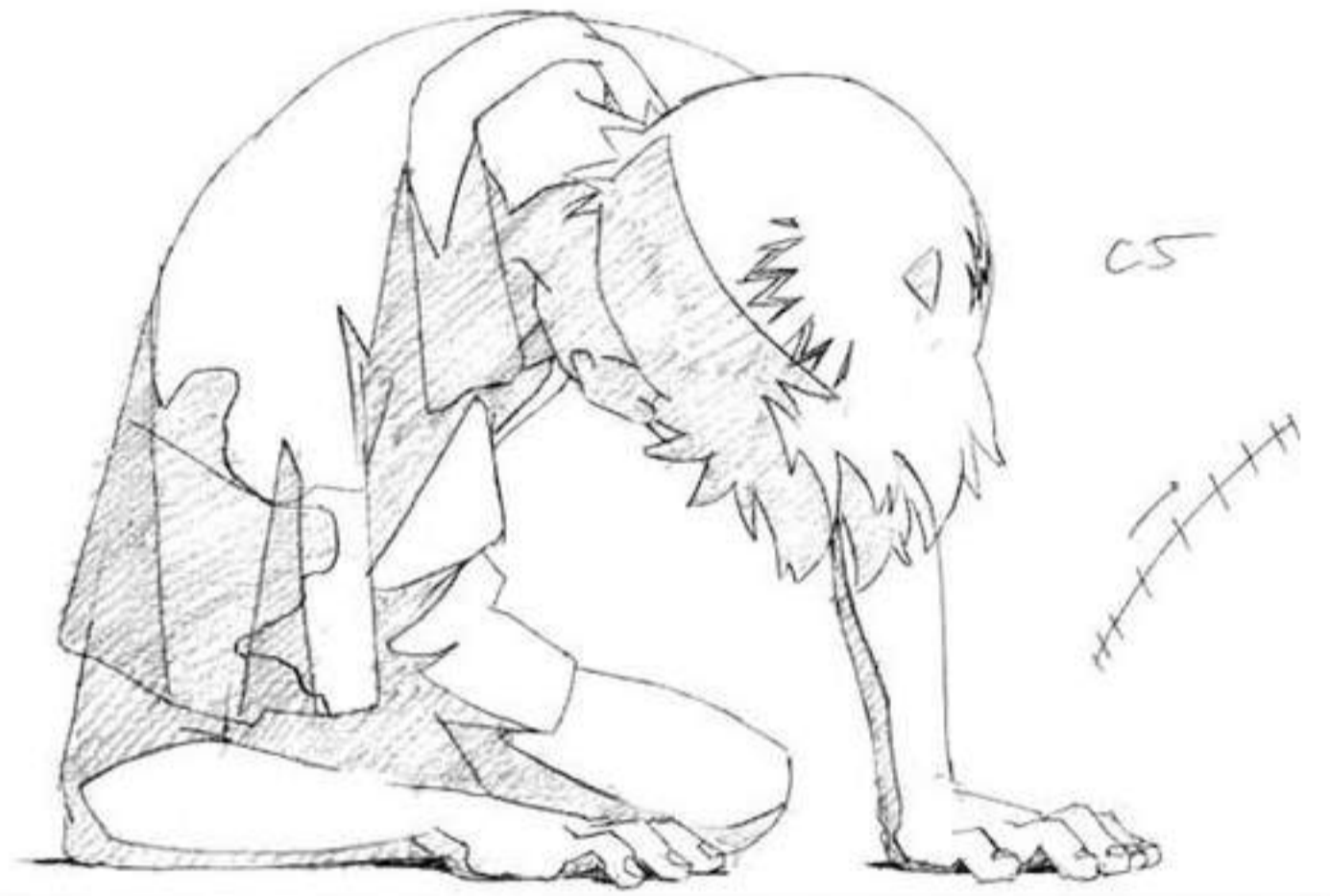
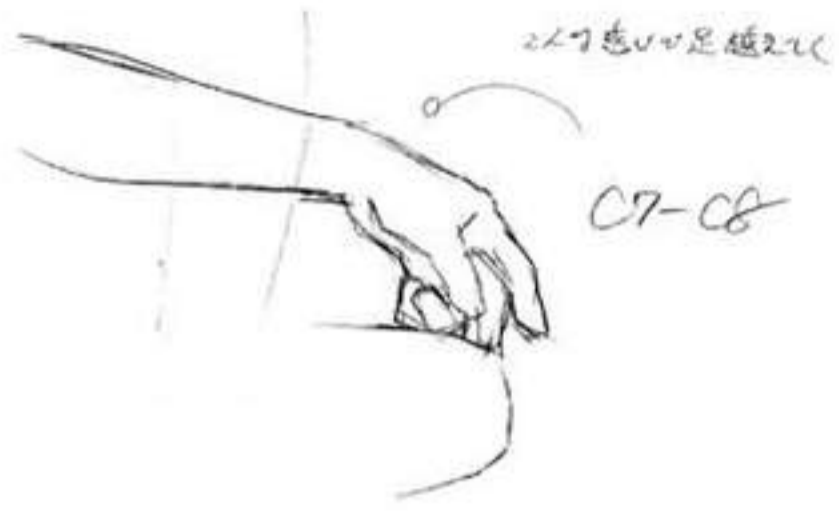

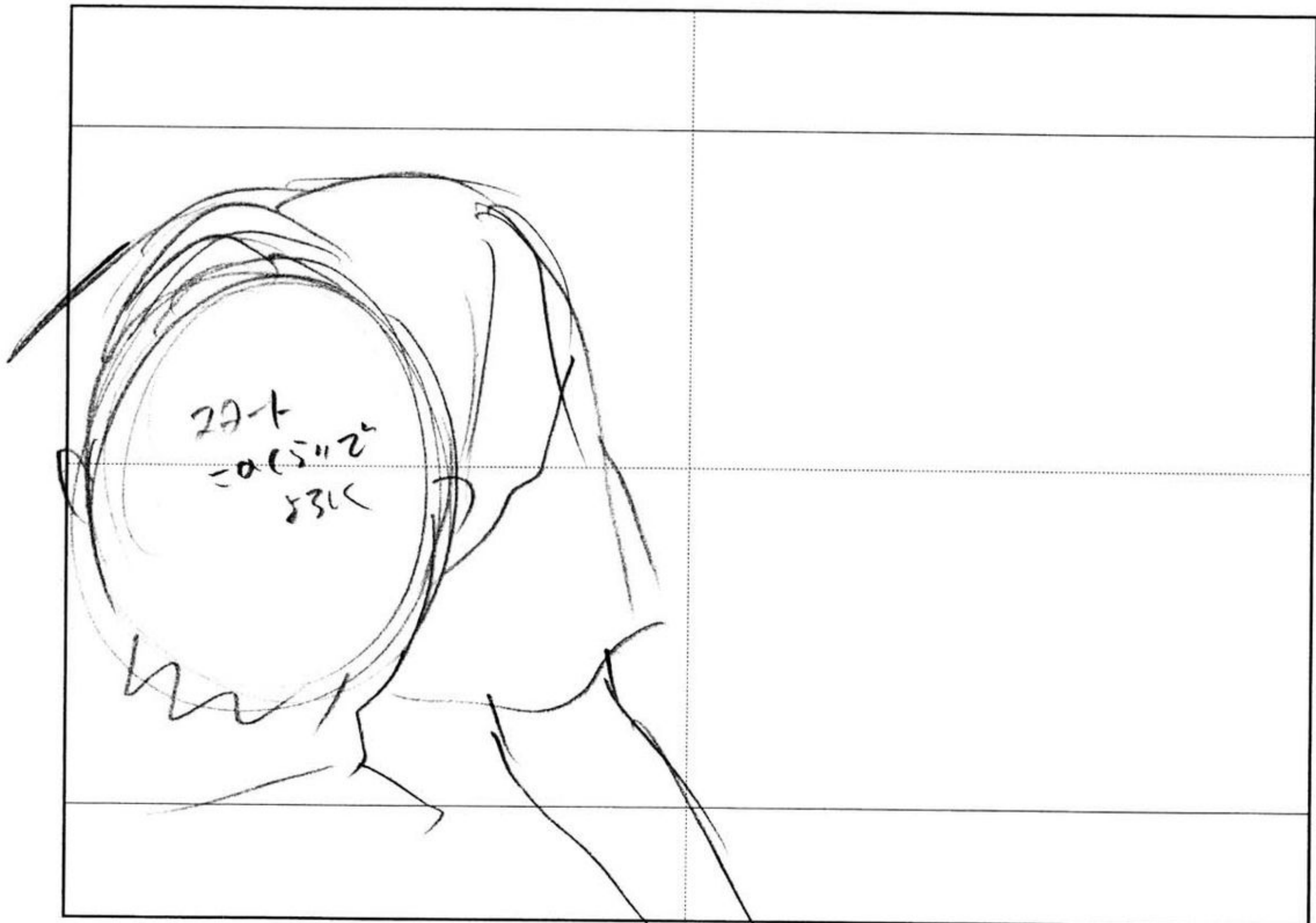
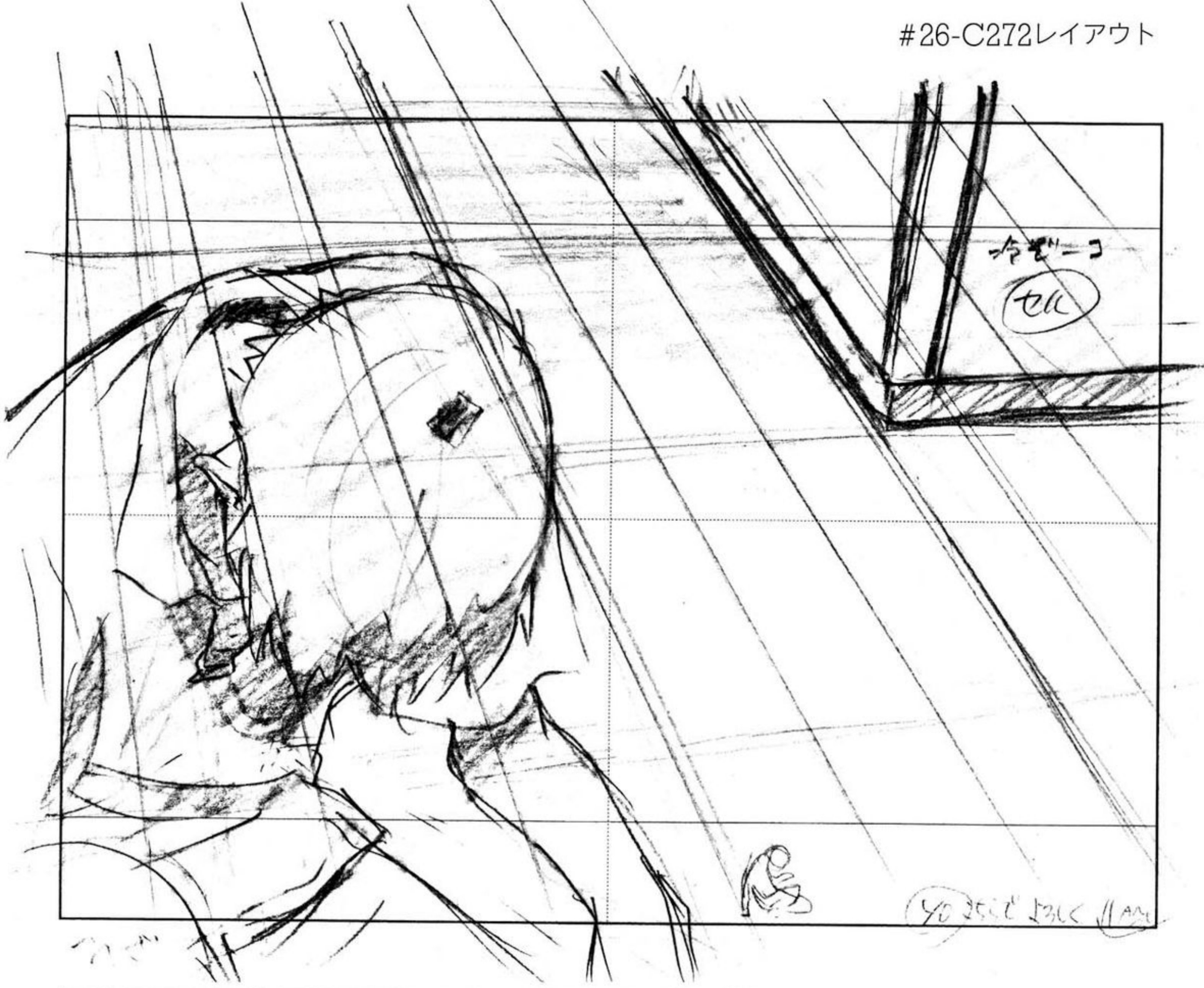

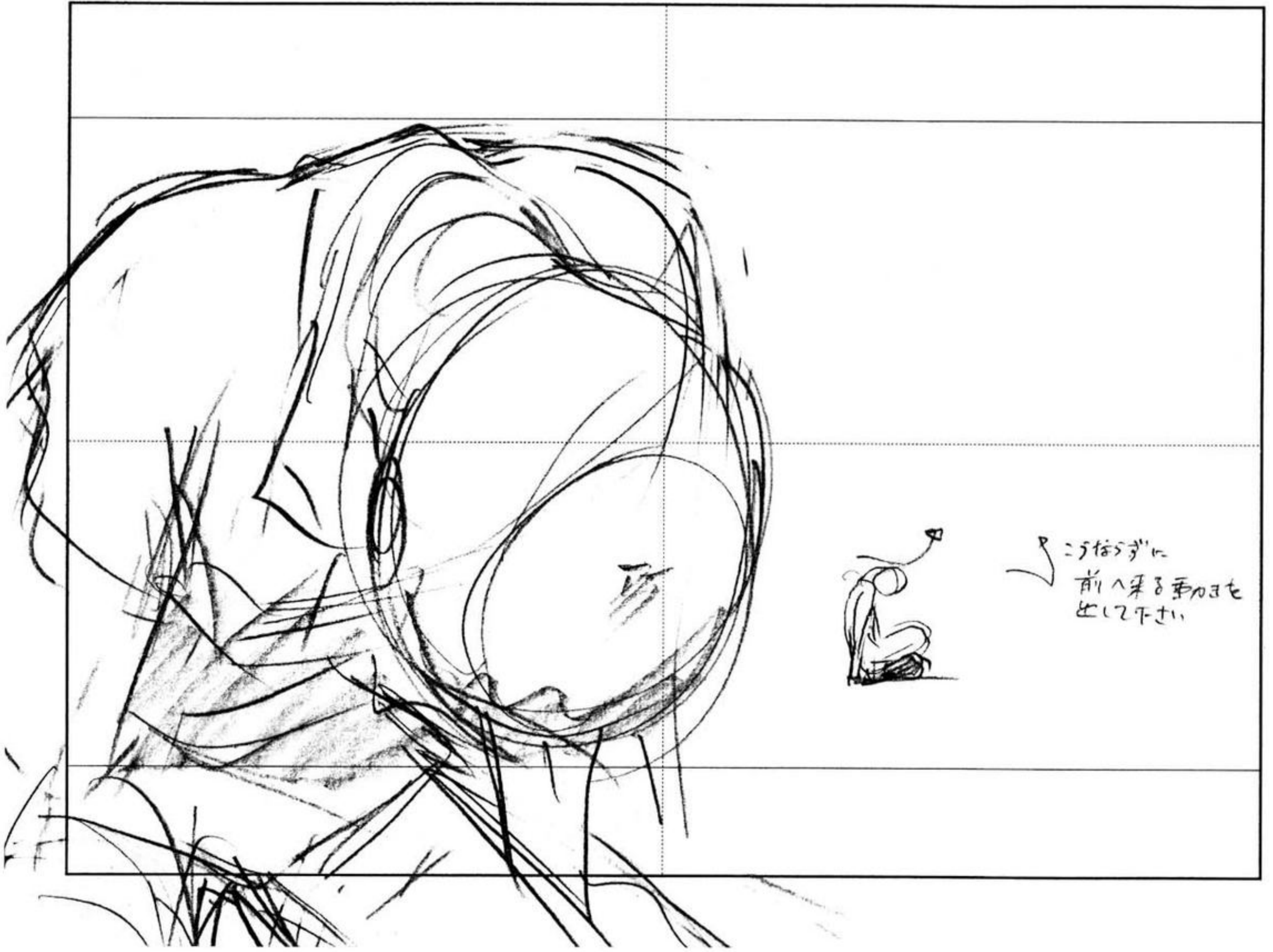

3

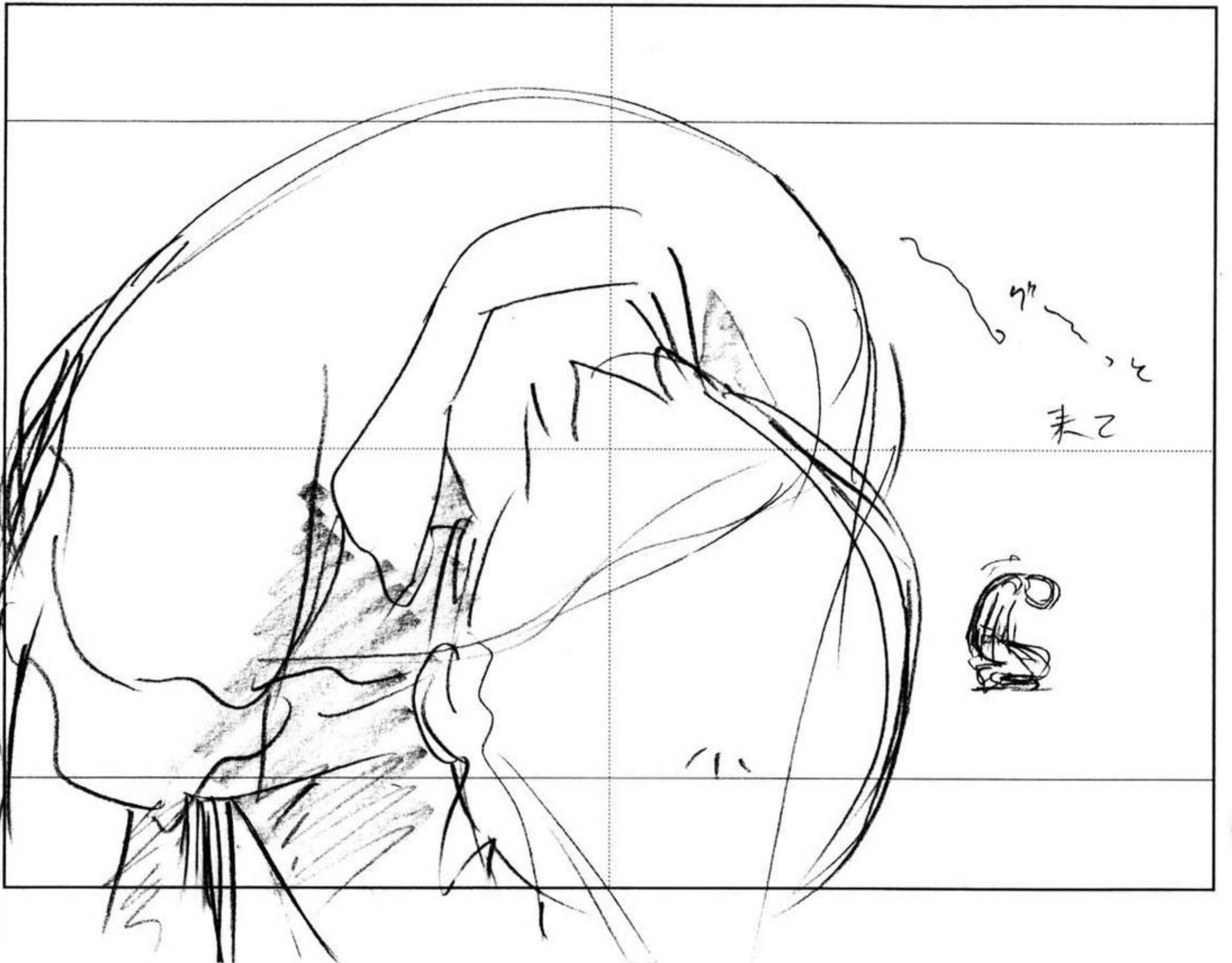

4

277

顔の向き
は C277
月線下へ



#26-C277レイアウト



ノンモレですか
「肩の息」が動きが止まるか？
有の場合
C2820 頭でピタ... と止まる

#26-C280レイアウト



ガイニング
天井ボヤ

702537 5362 H/170

#26-C281レイアウト

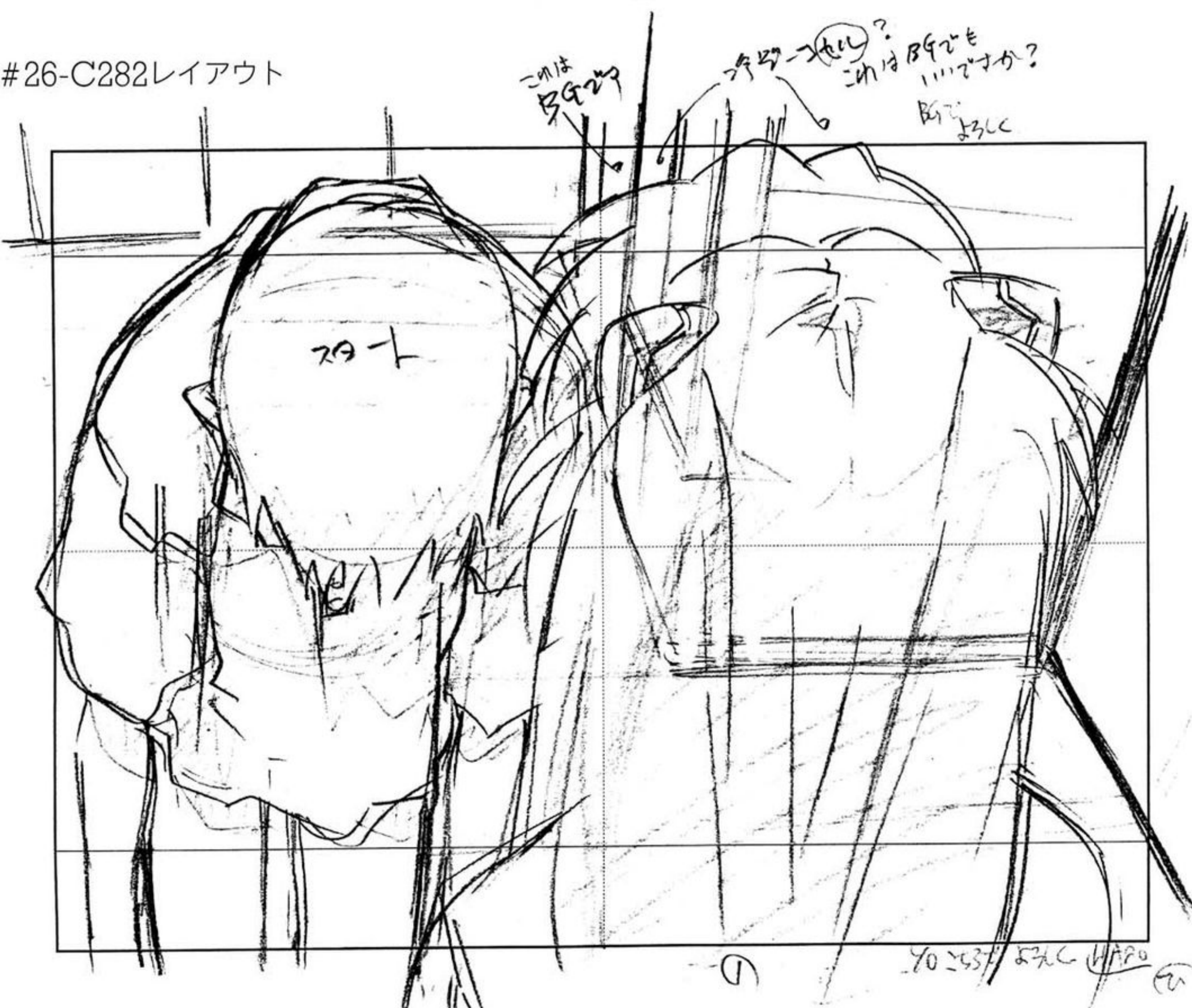

これは
B927

アキラニシロ?
これはB927を
11127か?

B927
5362

アキラ

702537 5362 H/170

#26-C282レイアウト

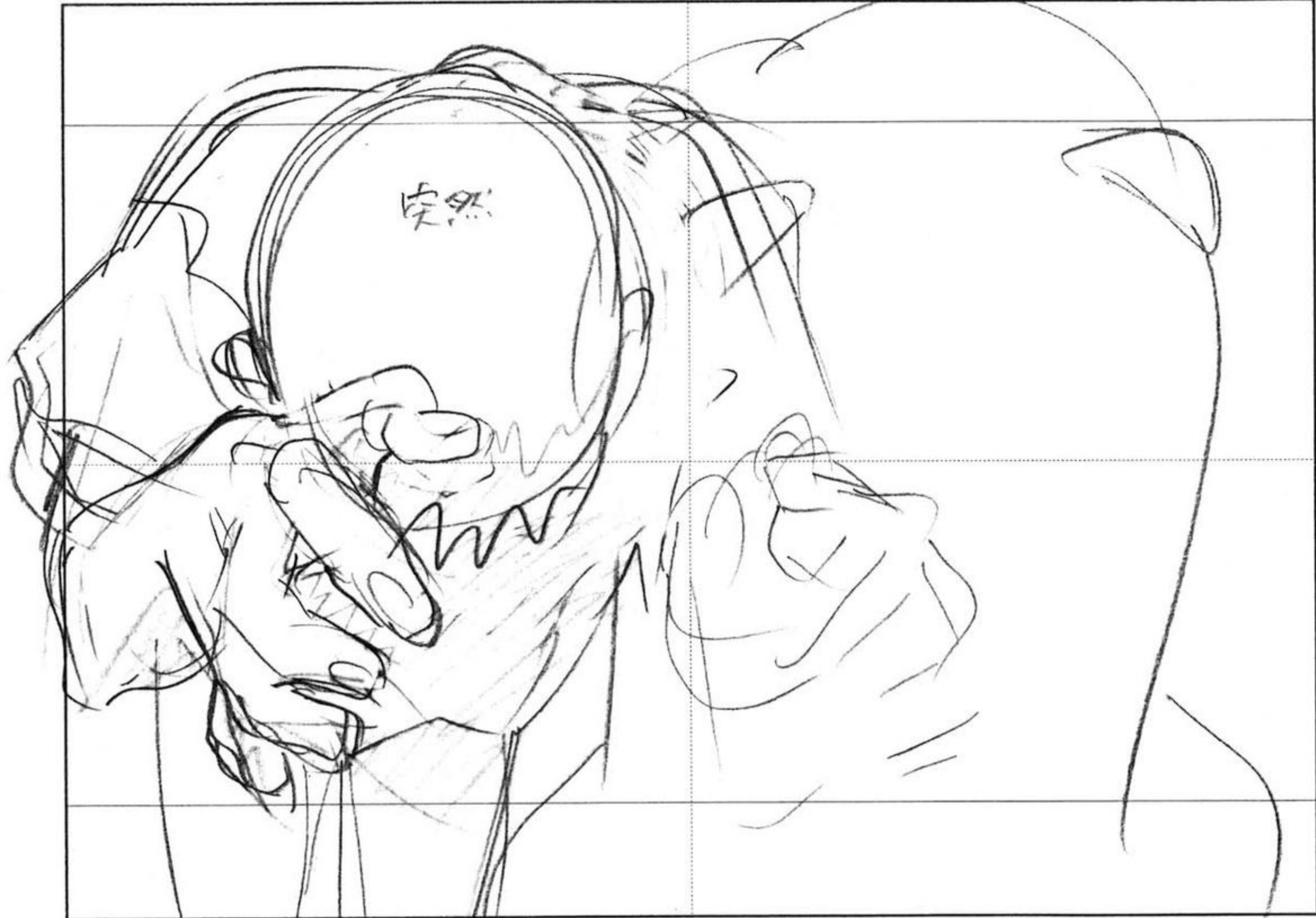

2

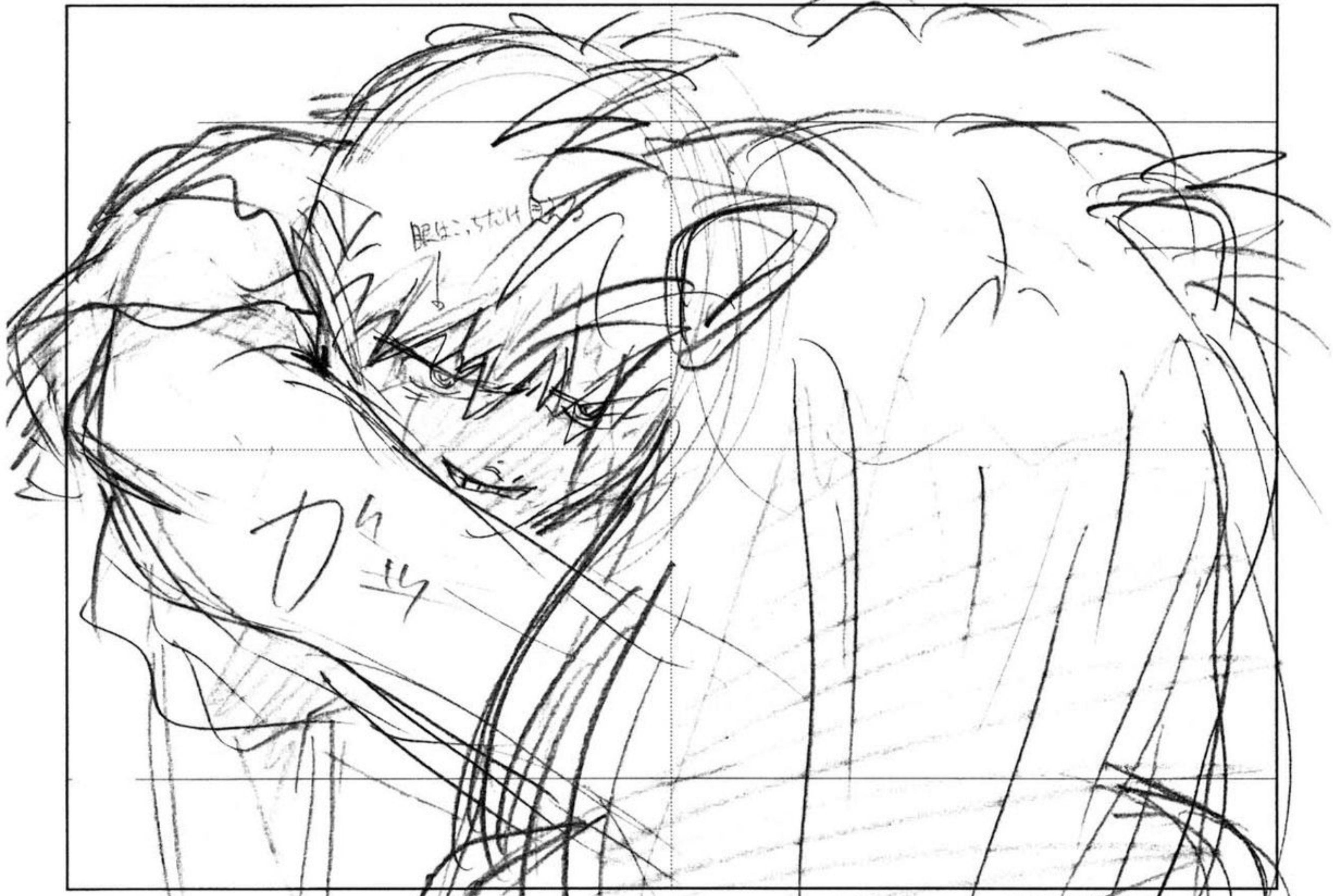

3

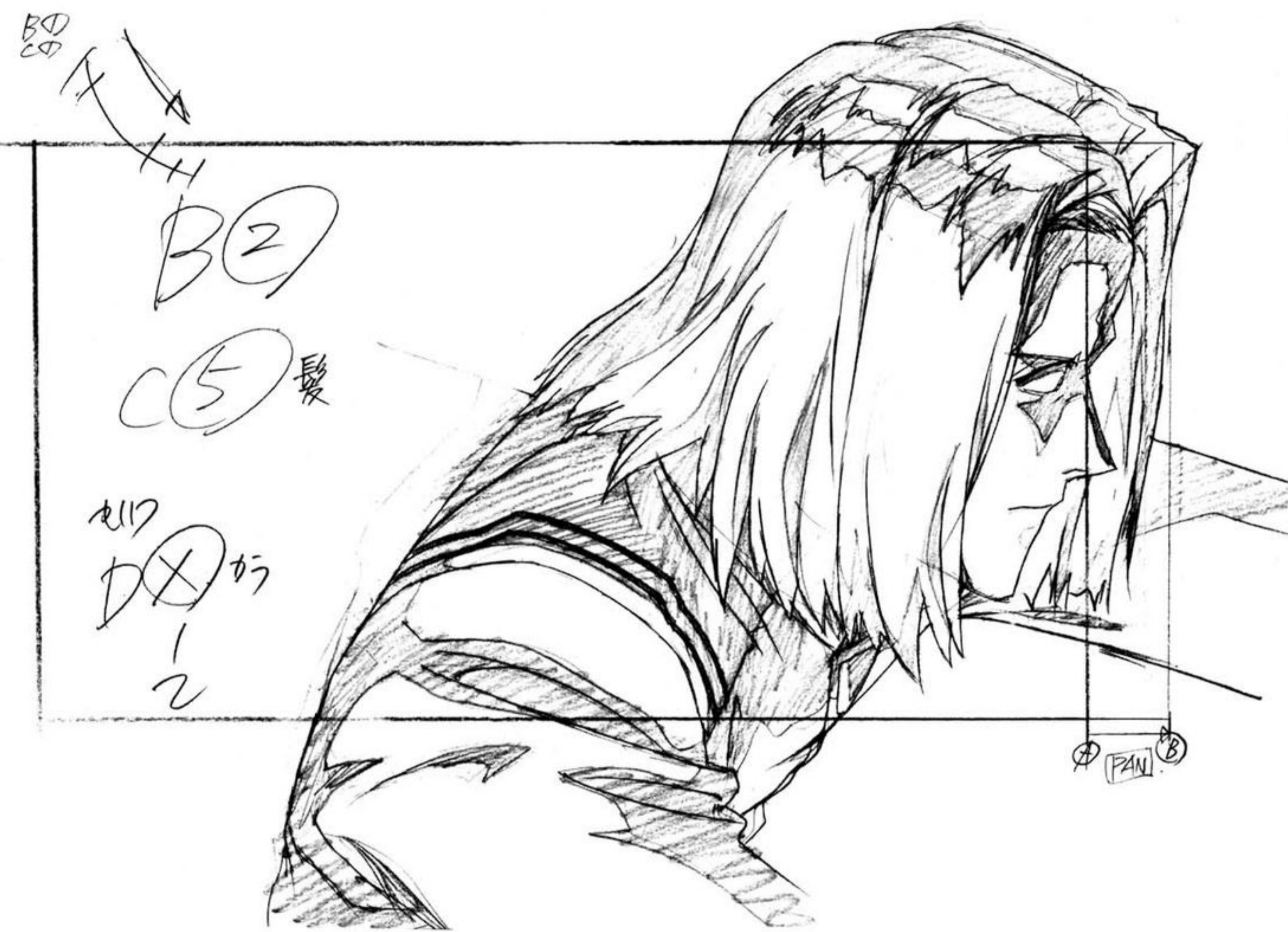

A	B	C	P	
②	✓			2
1				4
1				6
1				8
①③③				10
①				12
1				14
③④				16
2				18
				20
③				22
2				24
				26
⑤				28
①				30
				32
③				34
2				36
				38
③				40
2				42
				44
①				46
③				48
				50
2				52
③				54
2				56
				58
③				60
				62
①				64
				66

#26-C304

修正原画

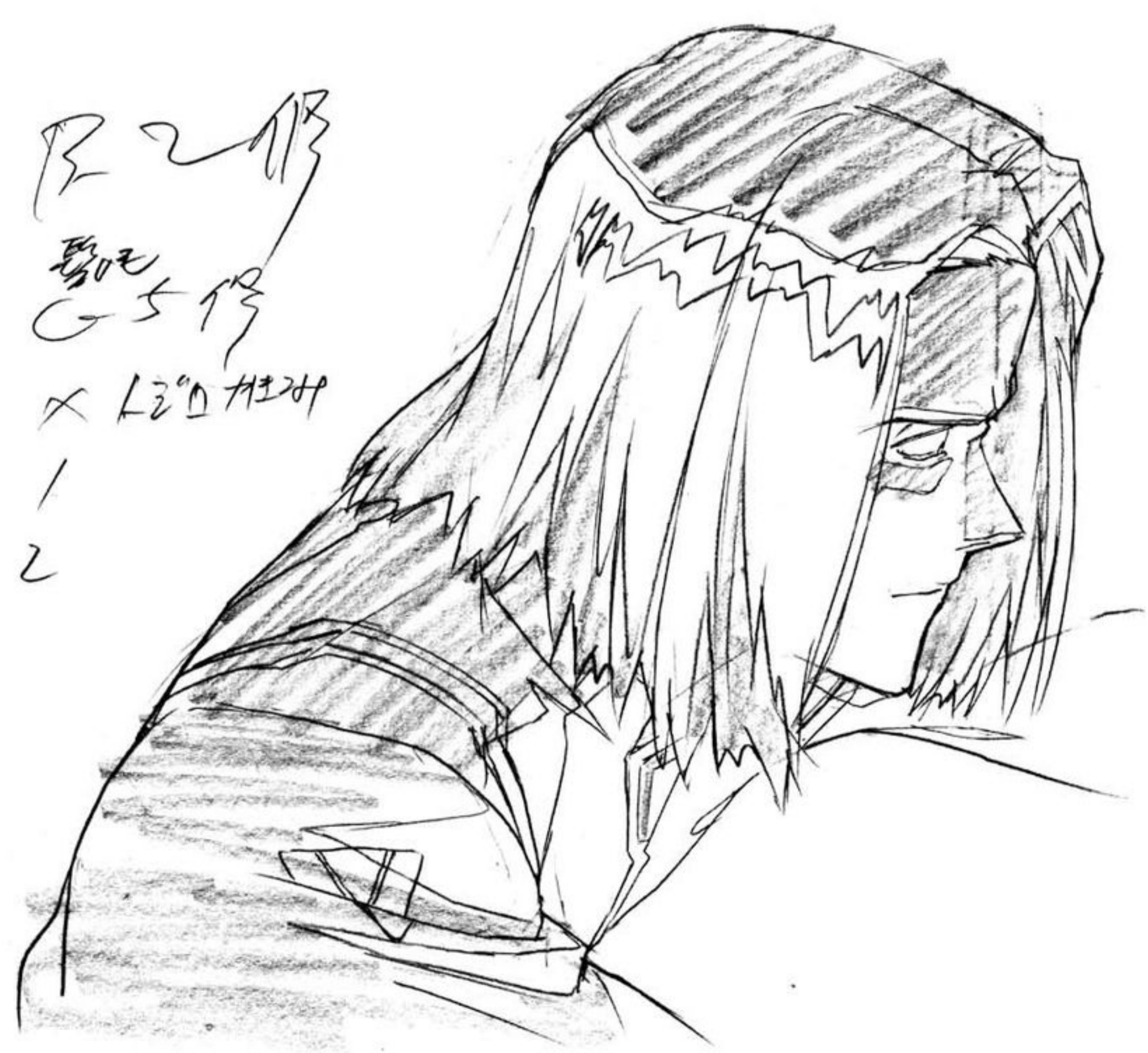

B(2) 髪
 C(5) 髪
 X L20 修正
 1
 2

タイムシート



修正原画

D3



B(1) C(2,3)

A(IX) D(4)



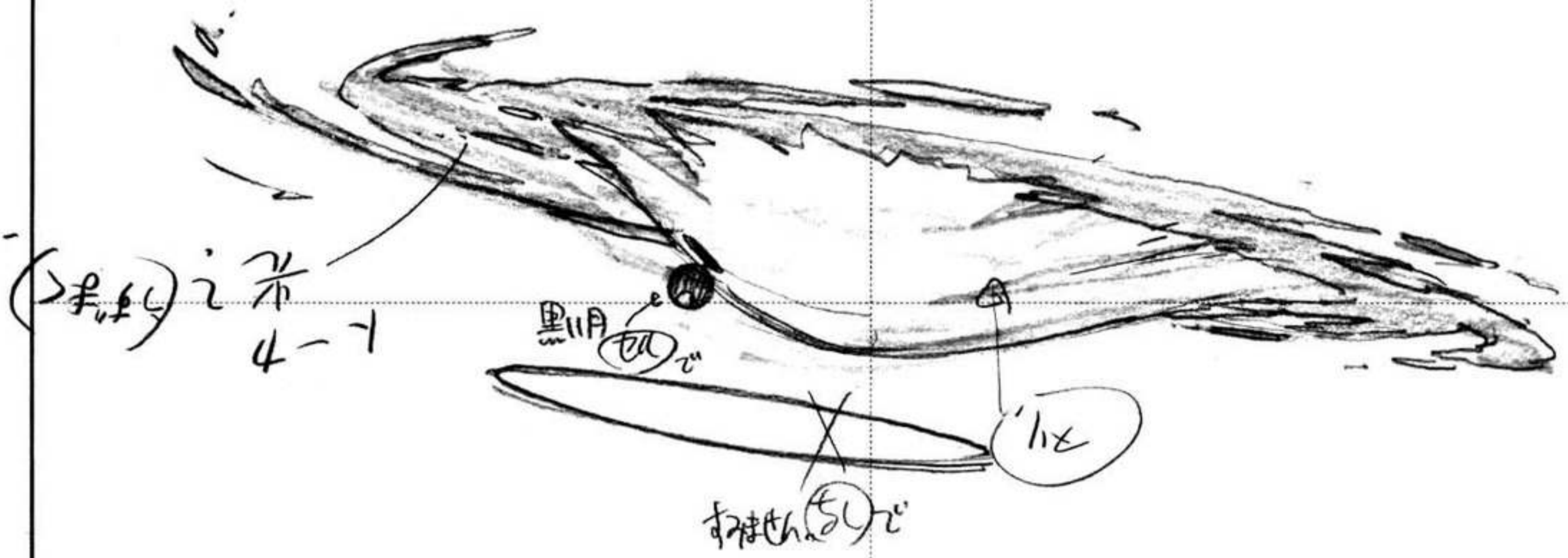

#26-C307レイアウト

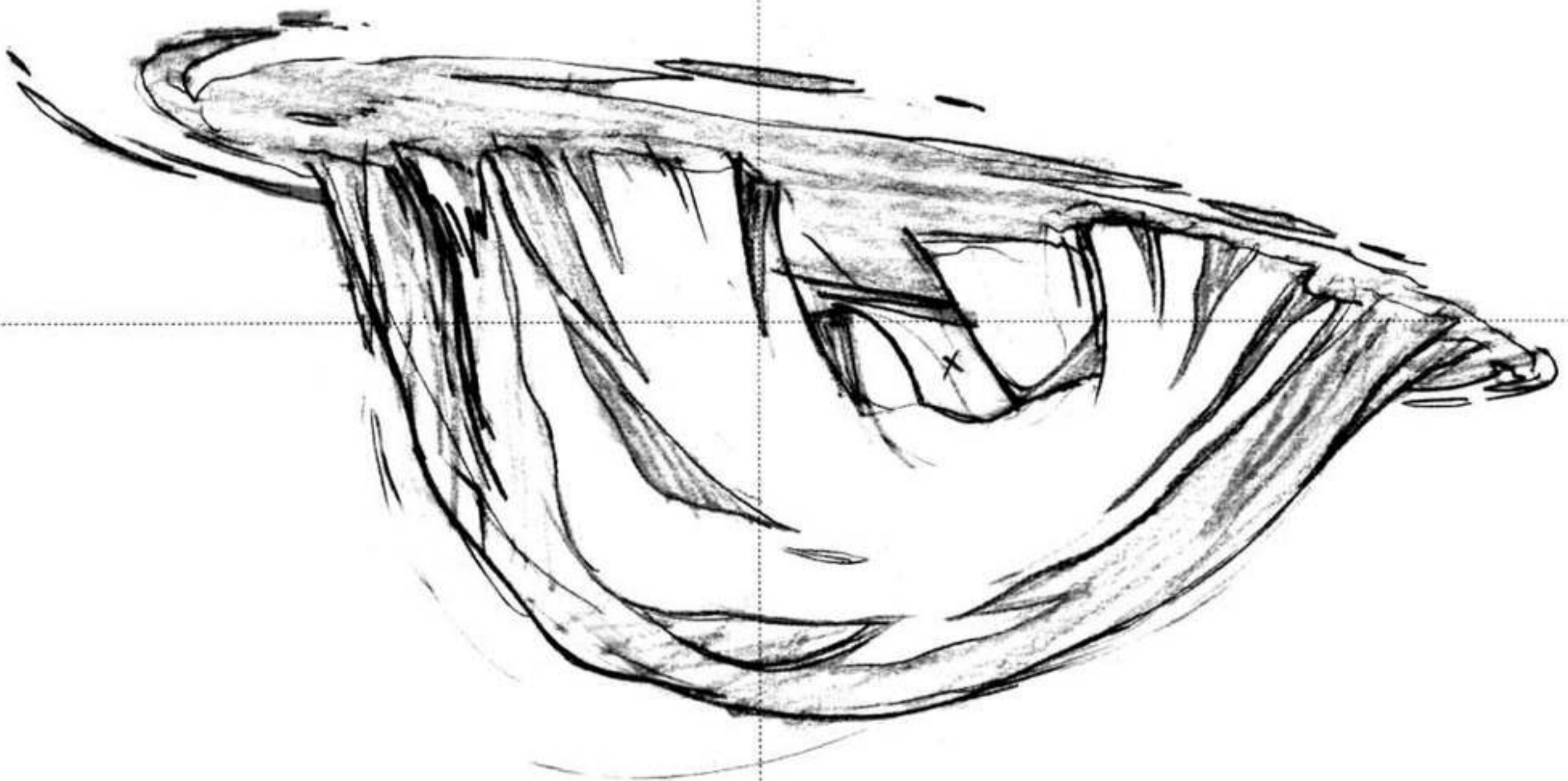



BG. 宇野

PAIN

D

★ 新面設計

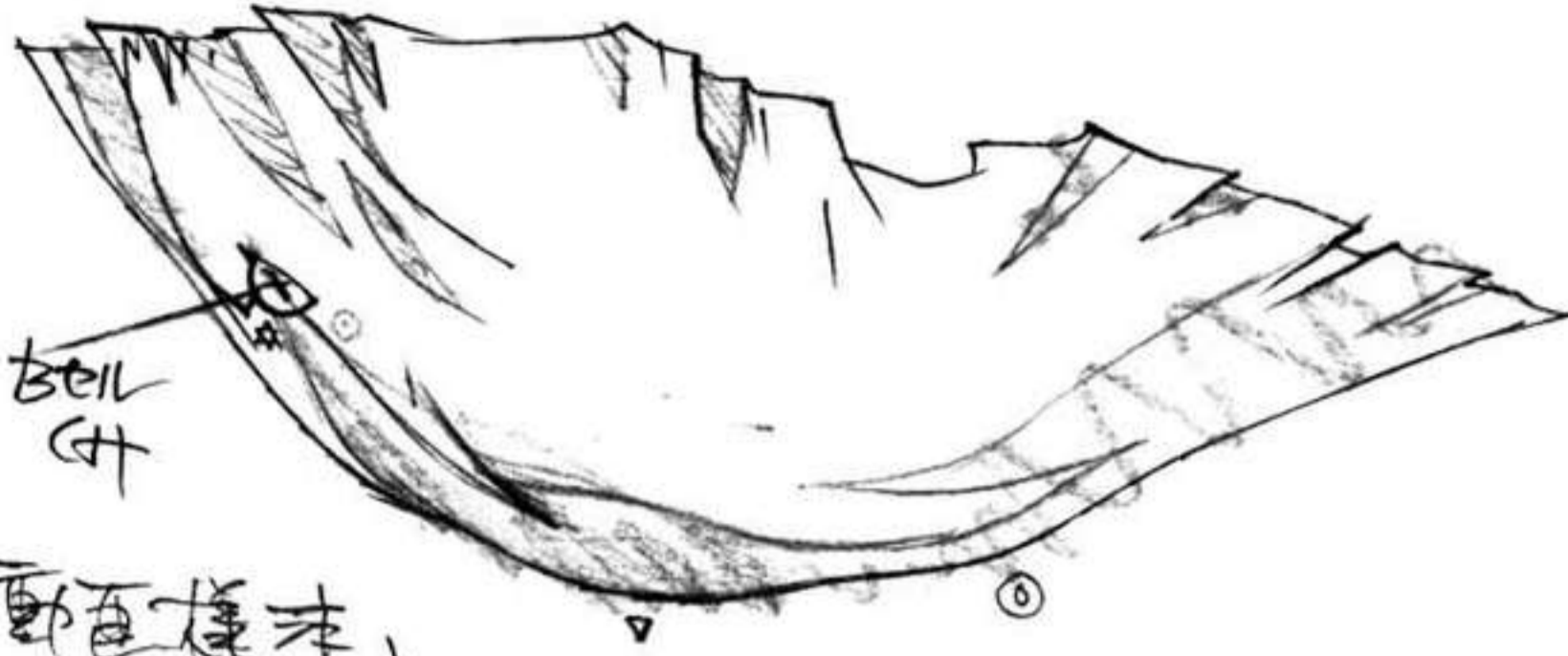

bell
↑

★ 新面設計、
↓ 以黒い色
↓ 体は可なり
↓ 行なう。

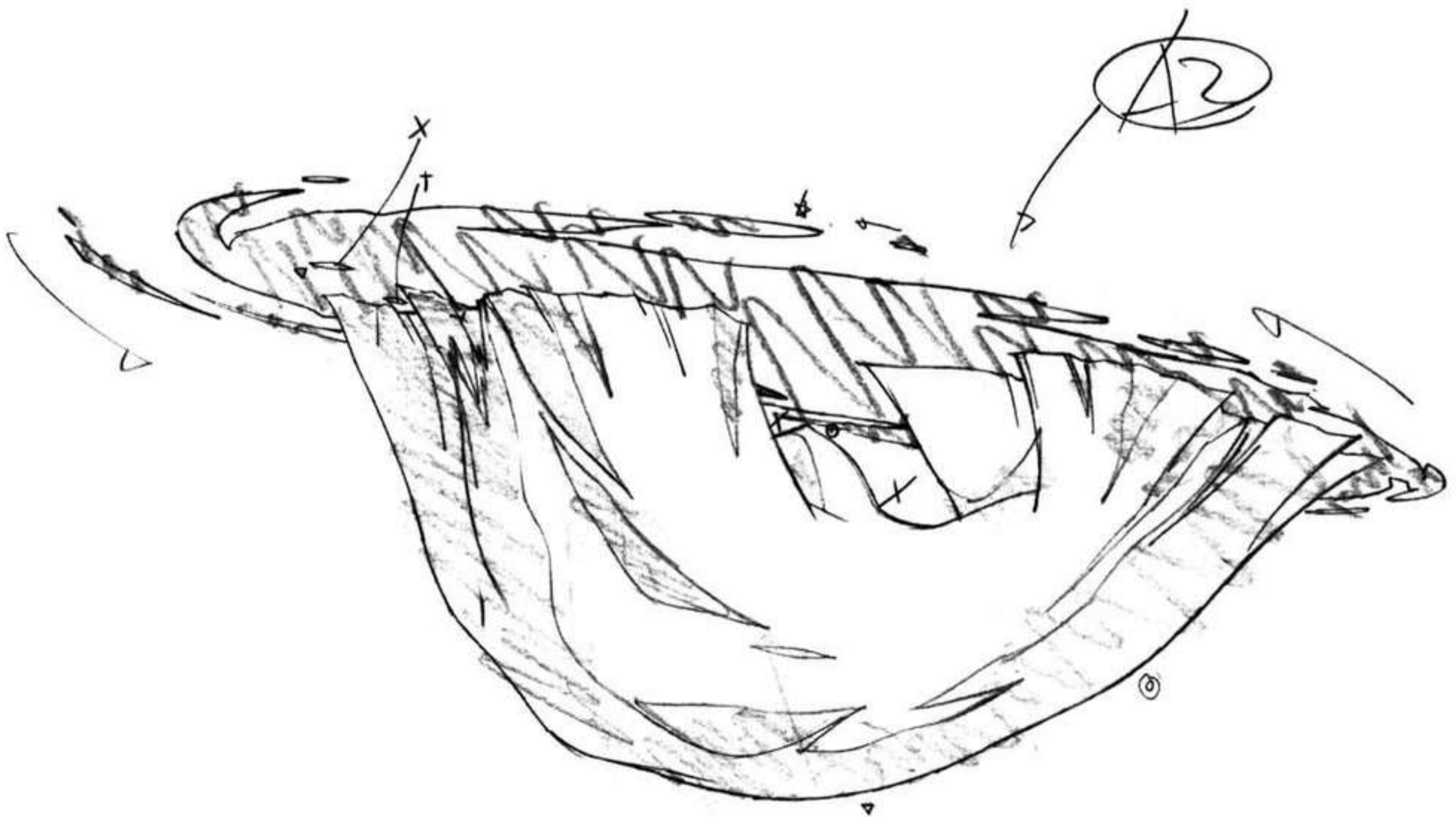
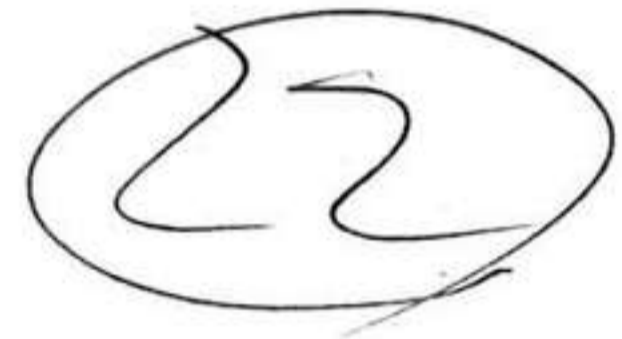

Belu CH A BEL 長の中
出さず

A BEL 長の中

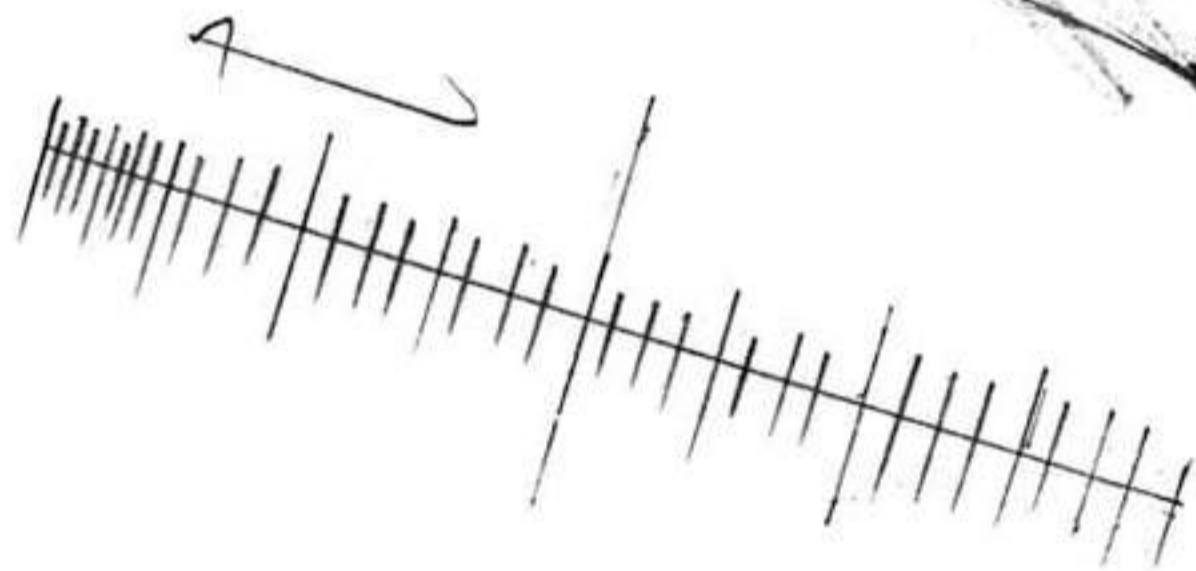
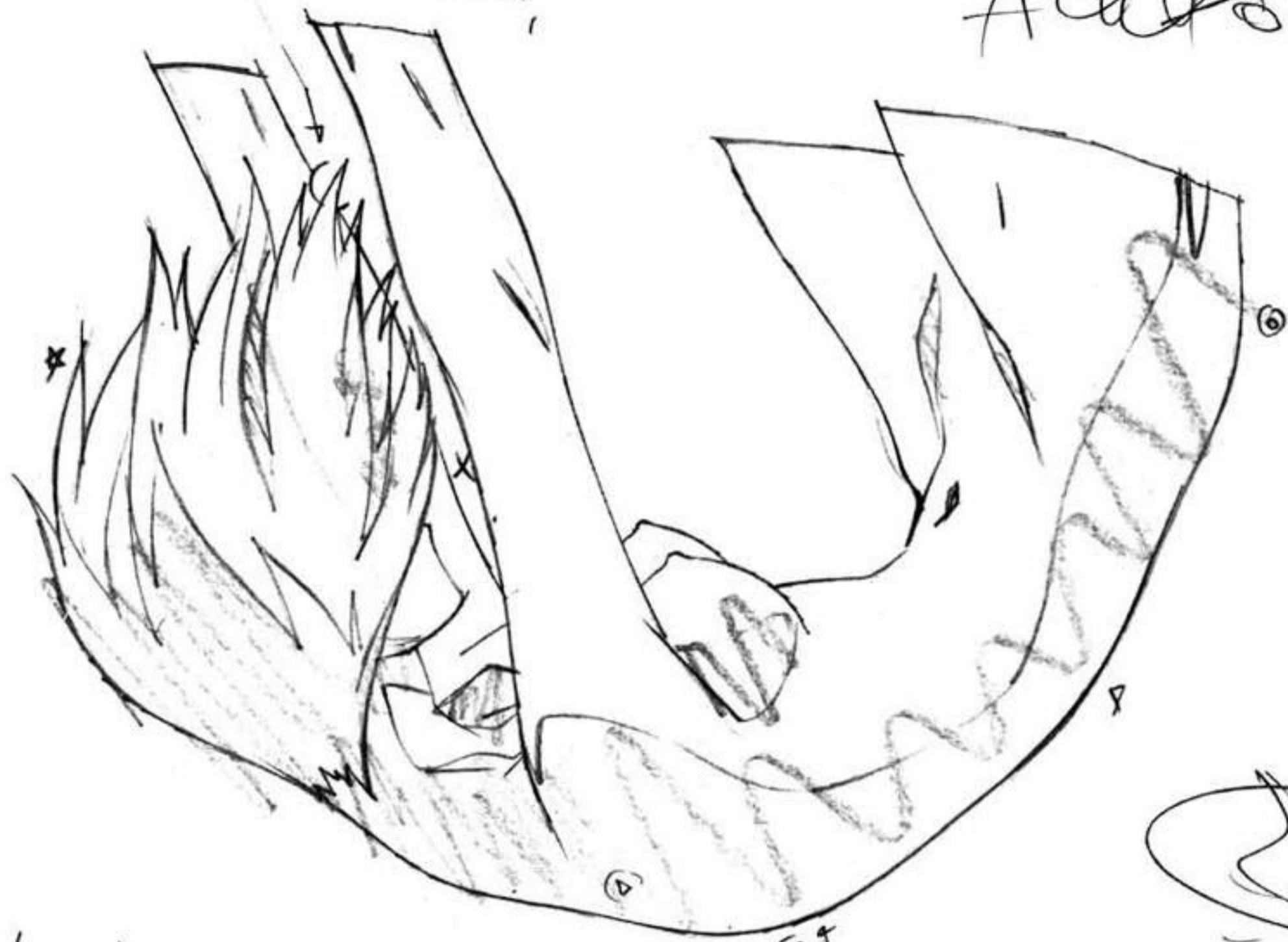

↑ 長の中
交へる様に
交へる様に

↑
↓
↑
↓

END

耳の横
↑ 長の中
↑ 長の中
↑ 長の中
↑ 長の中

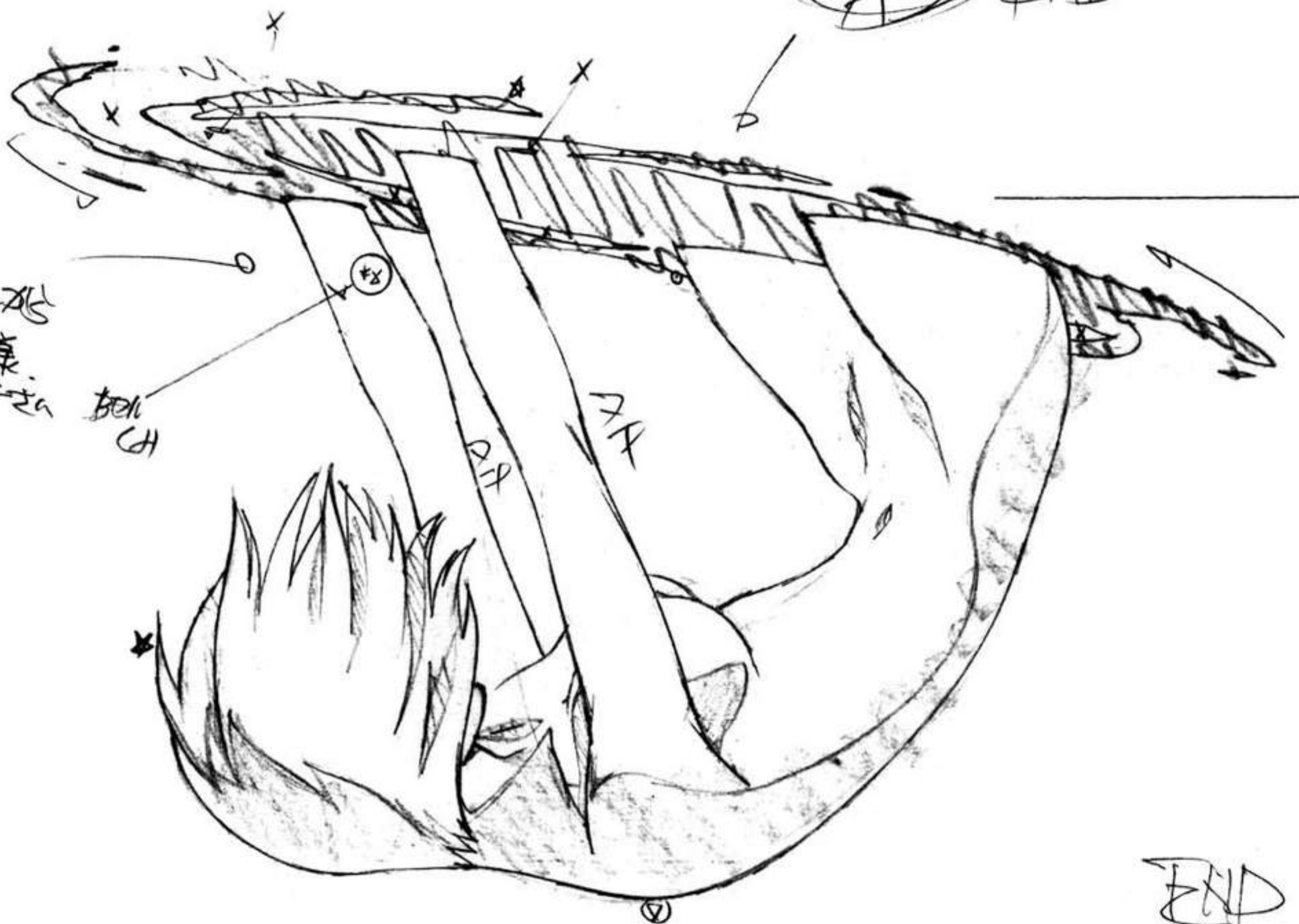

Belu CH

↑

↑

END

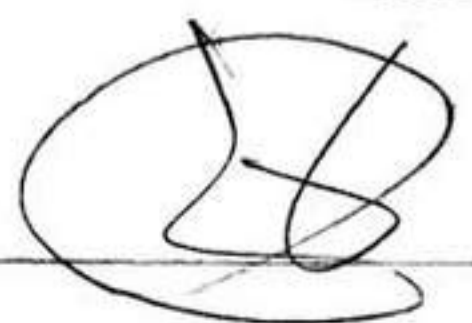

#26-C309L1アヲト

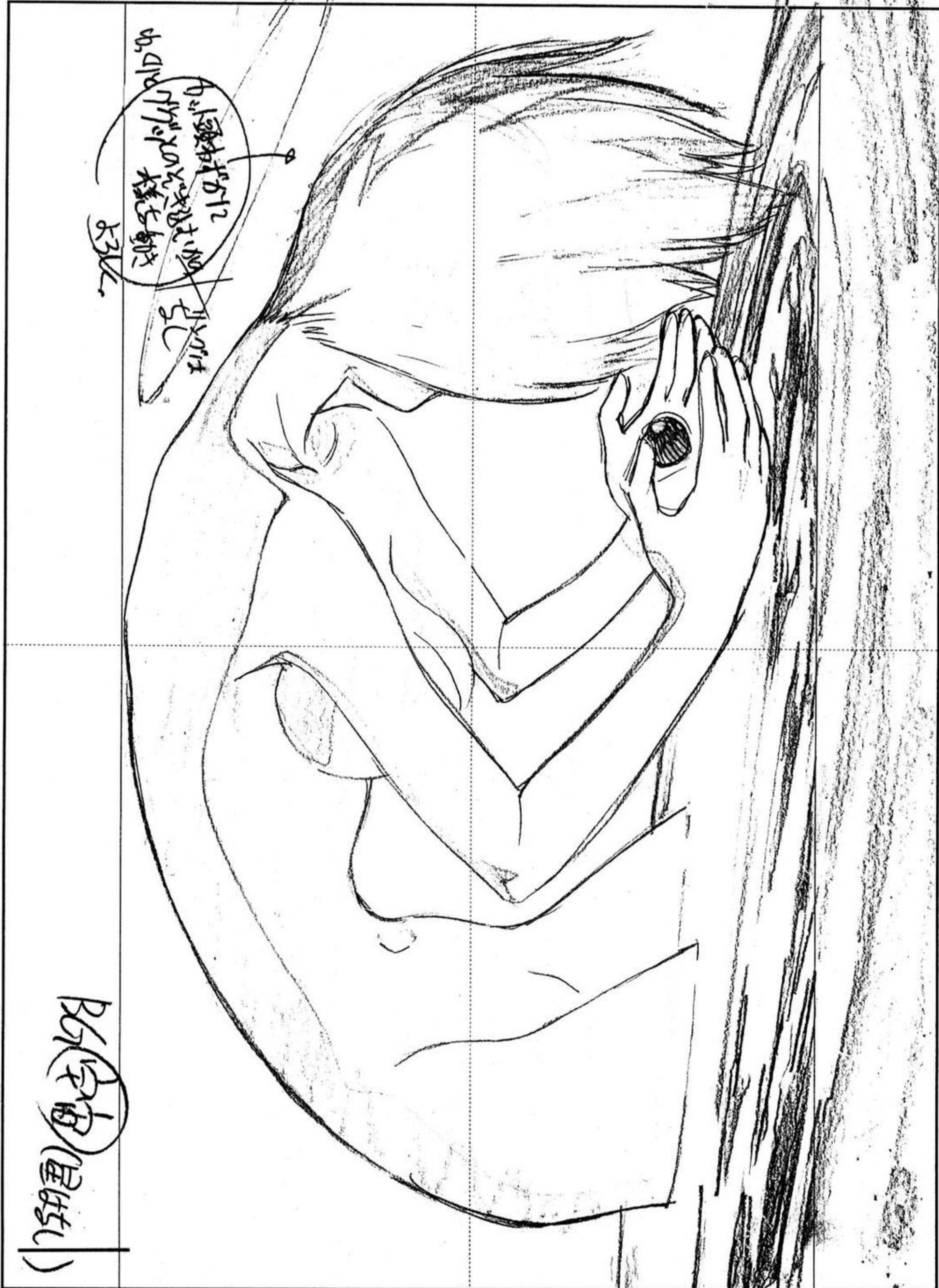

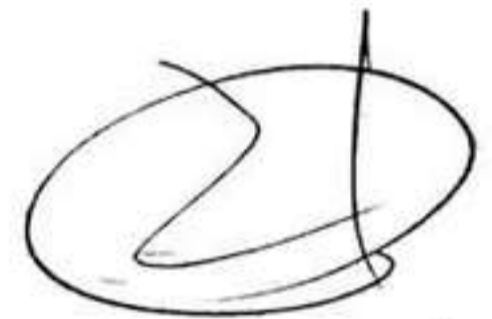

Handwritten signature or mark.

Handwritten text: 7d (ツ) の 非 d

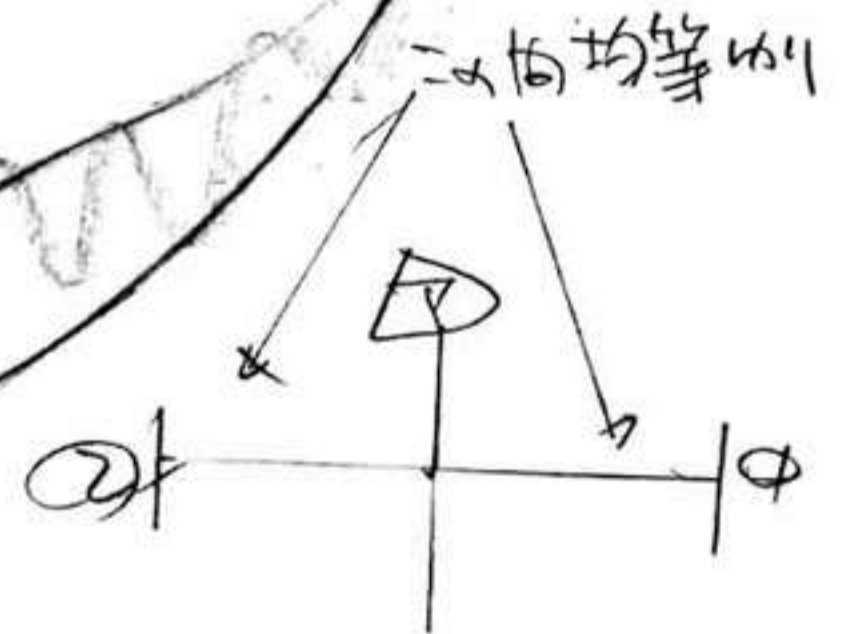

Handwritten signature or mark.



7A

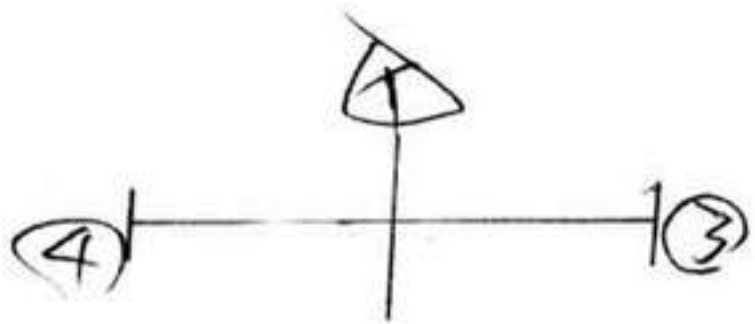
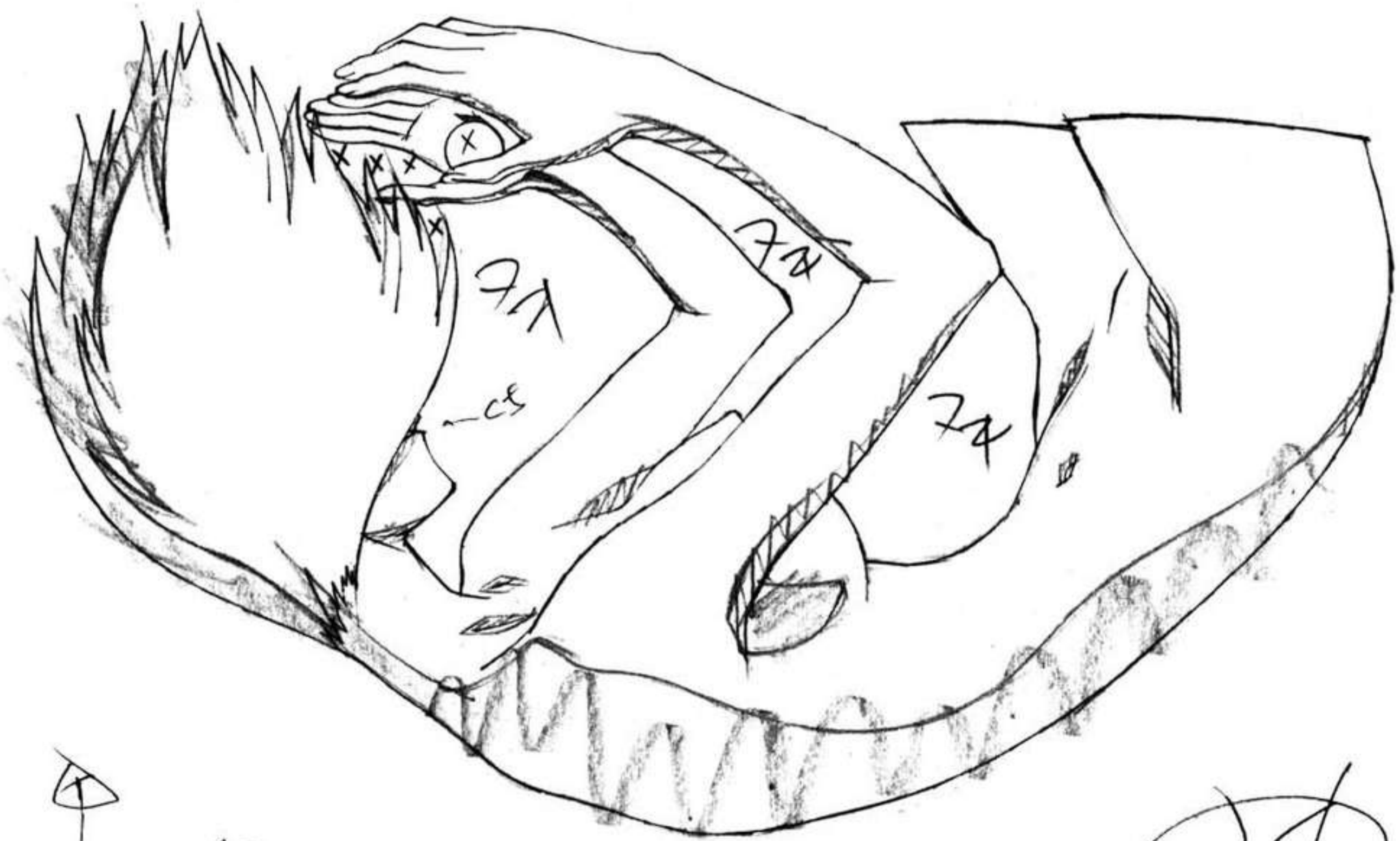

7A



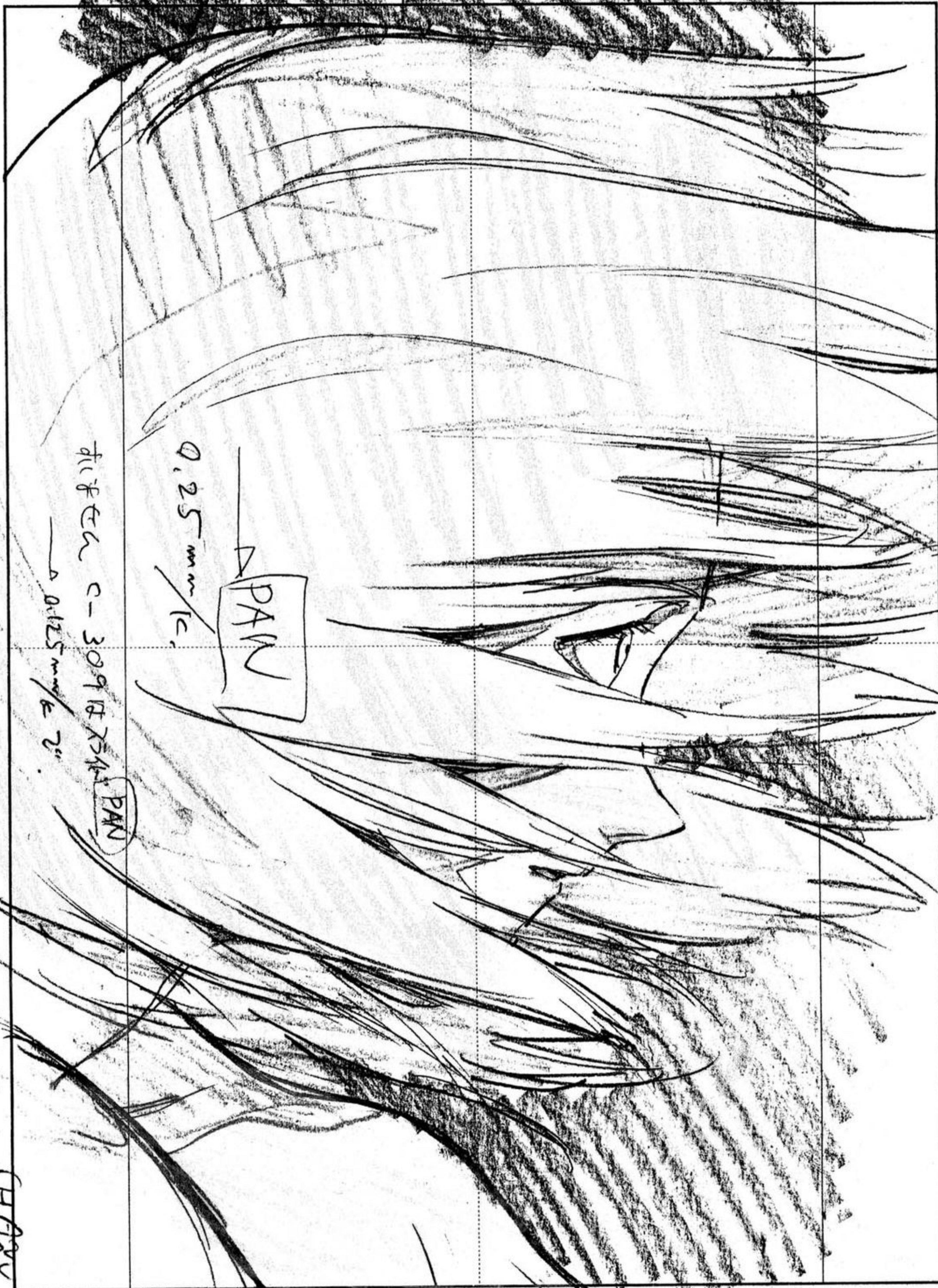

#26-C310L-17710

H.A.P.V.

(2)

#26-C310

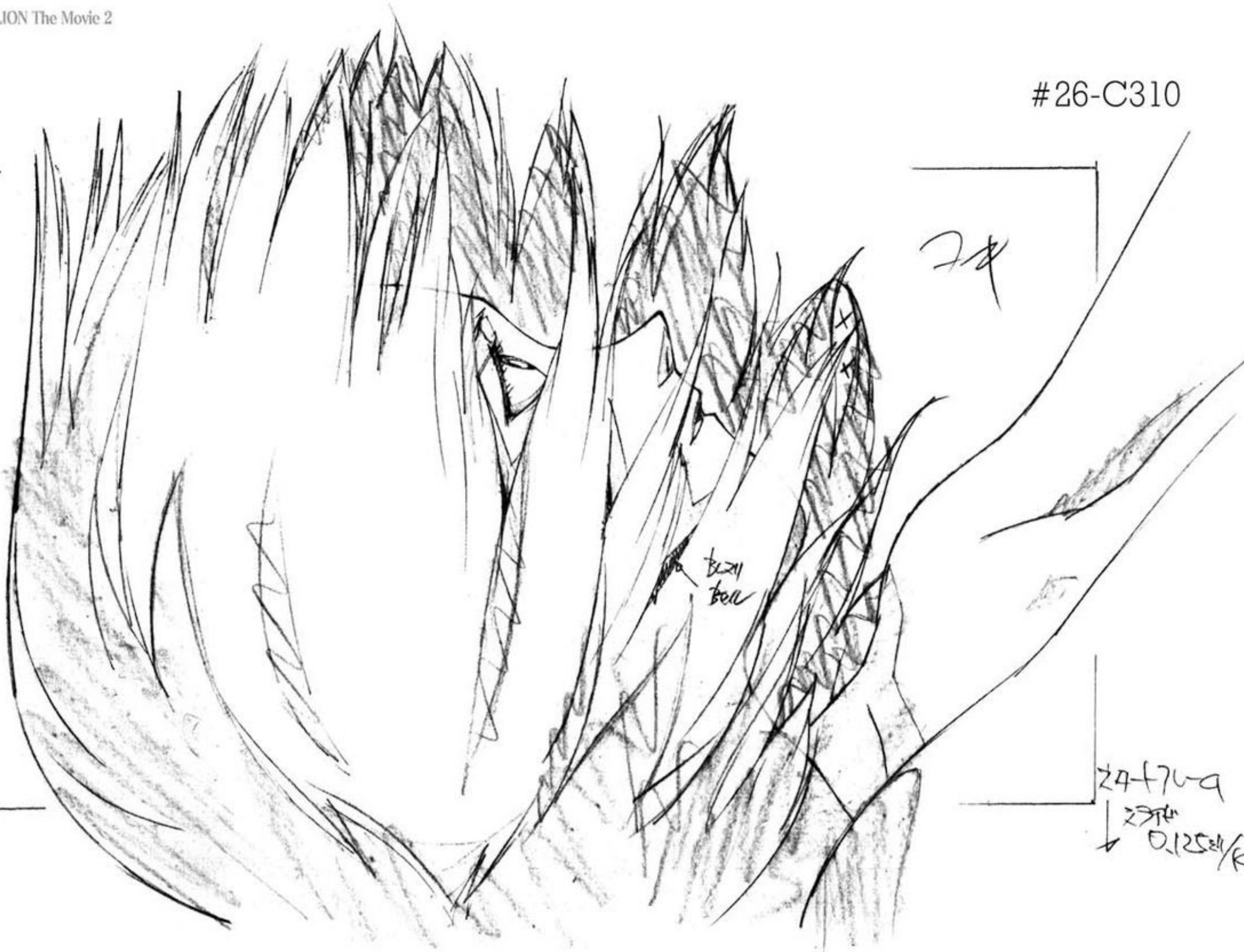

顔体

(A)

2-11-(C1)

髪

(B)

2-11-

(D1)

24

24
24

24+70-9
24
0.125mm



髪
2-11-
F.10

髪

(B2)

髪

2-11-
(D2)

24
24
24

24

24

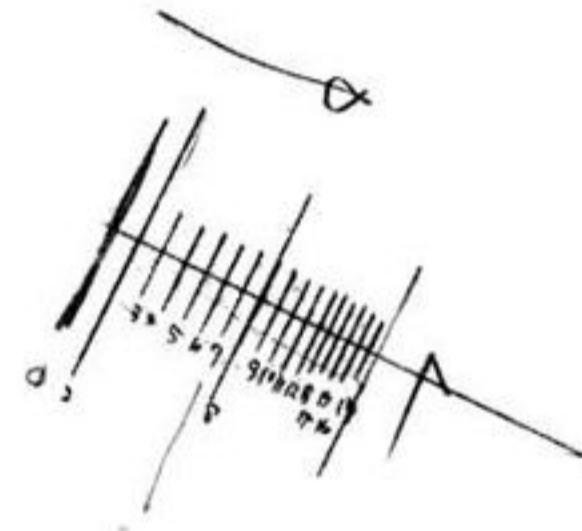

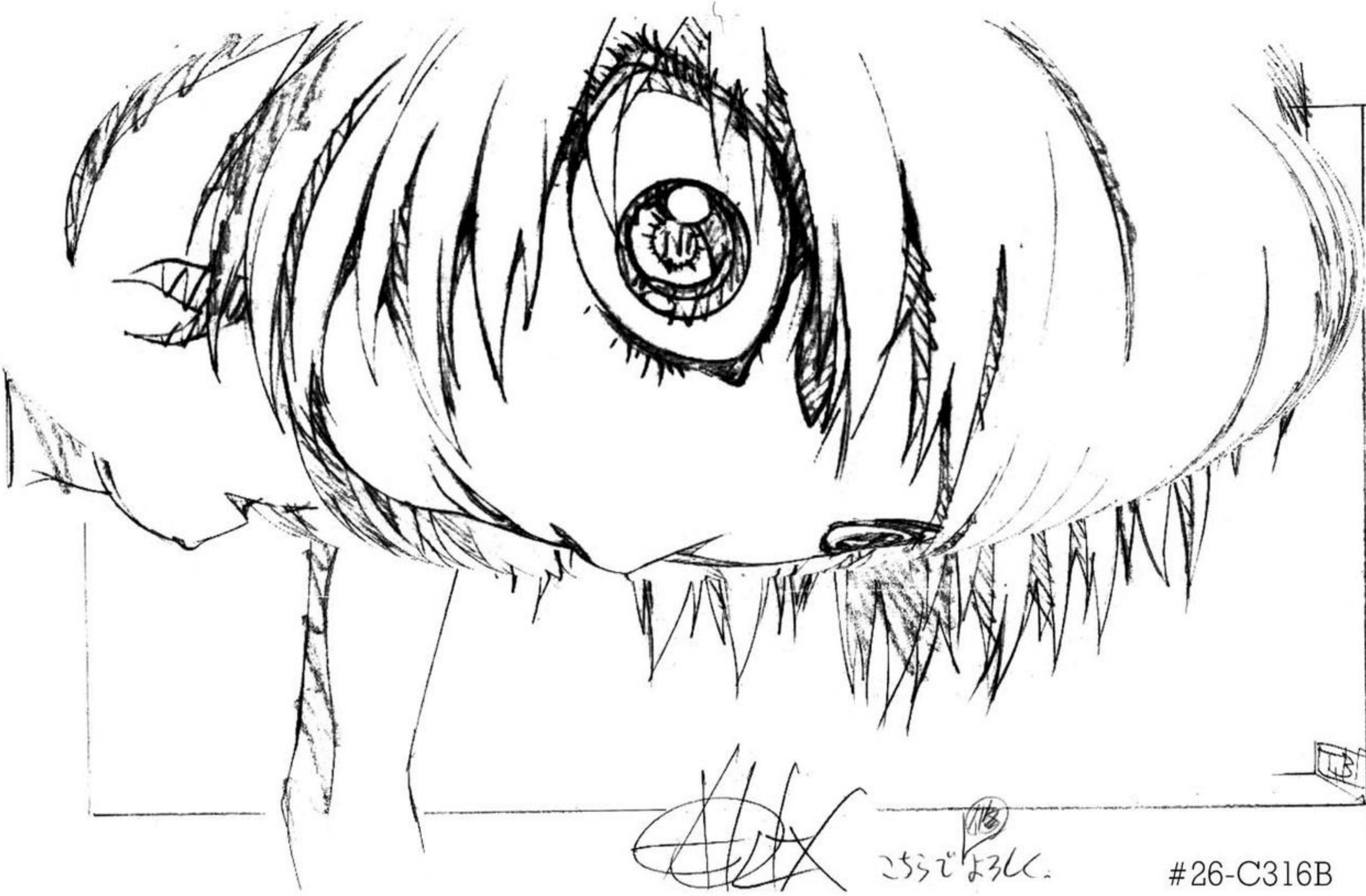

[Signature]

こさこよ366

#26-C316B

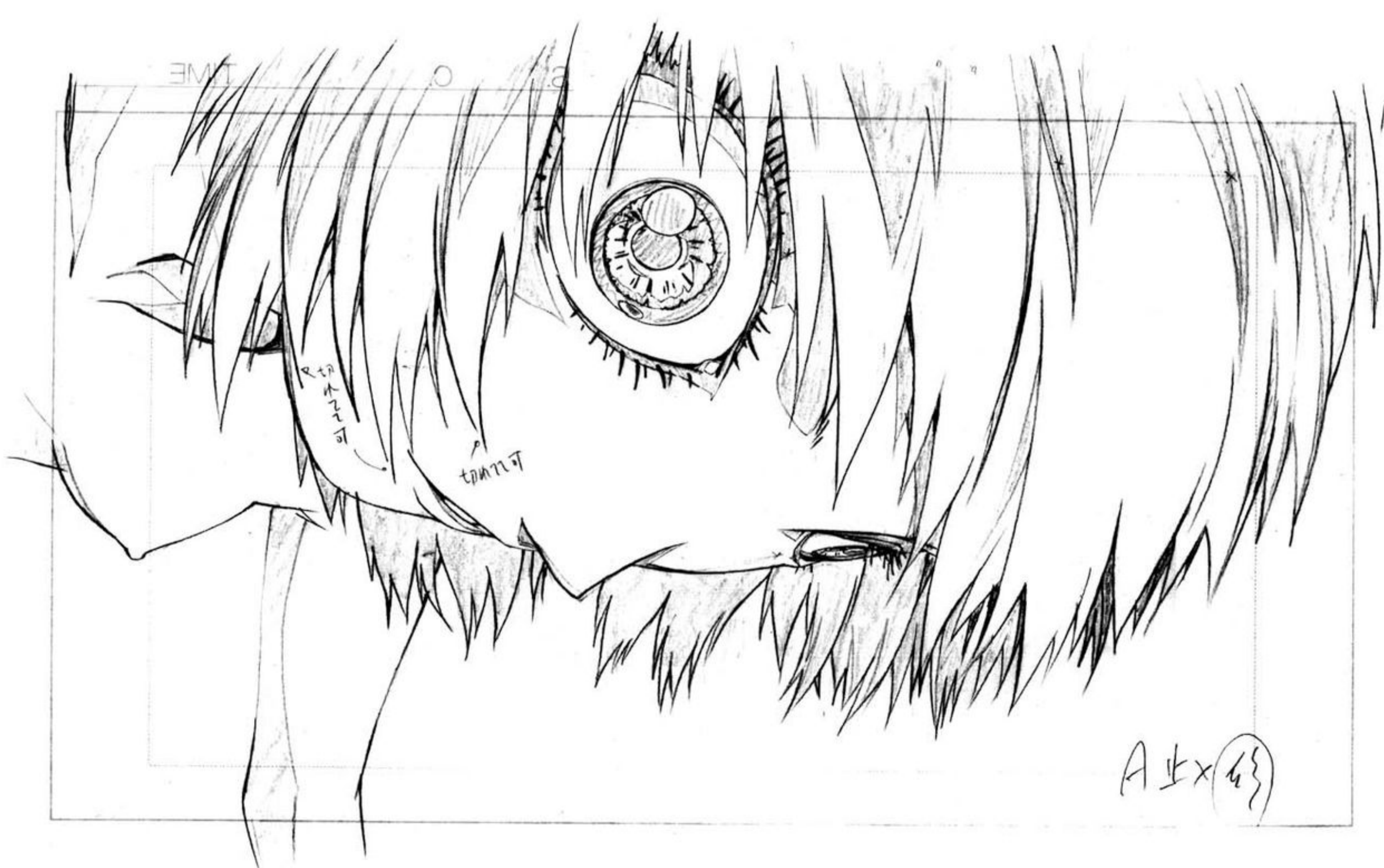

TIME

C

E

A 止 x (63)

A 止 x (63)

A 止 x (63)

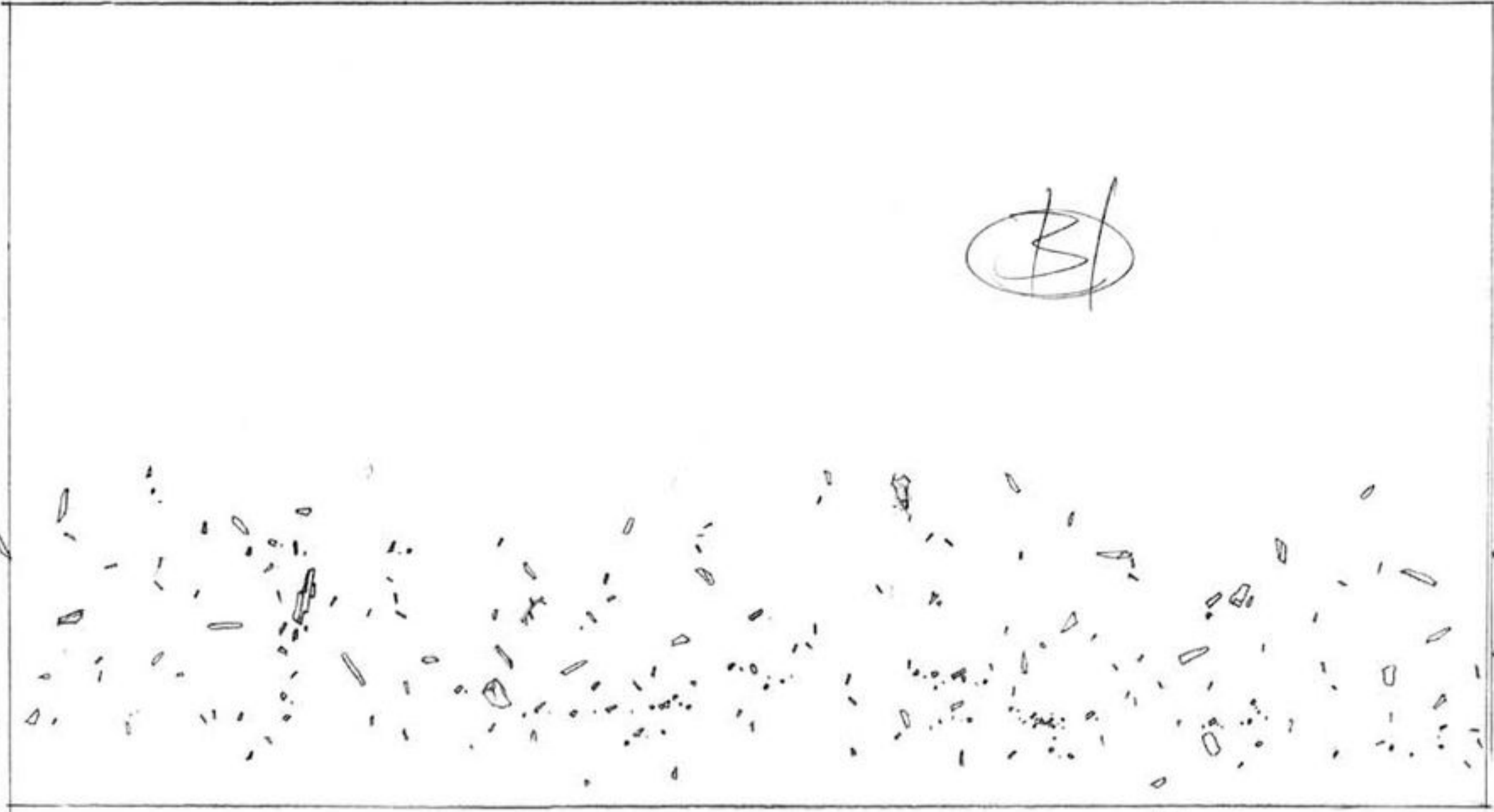

↑
2511 表
↓
2511 表
↓
2511 表

↑
2511 表
↓
2511 表

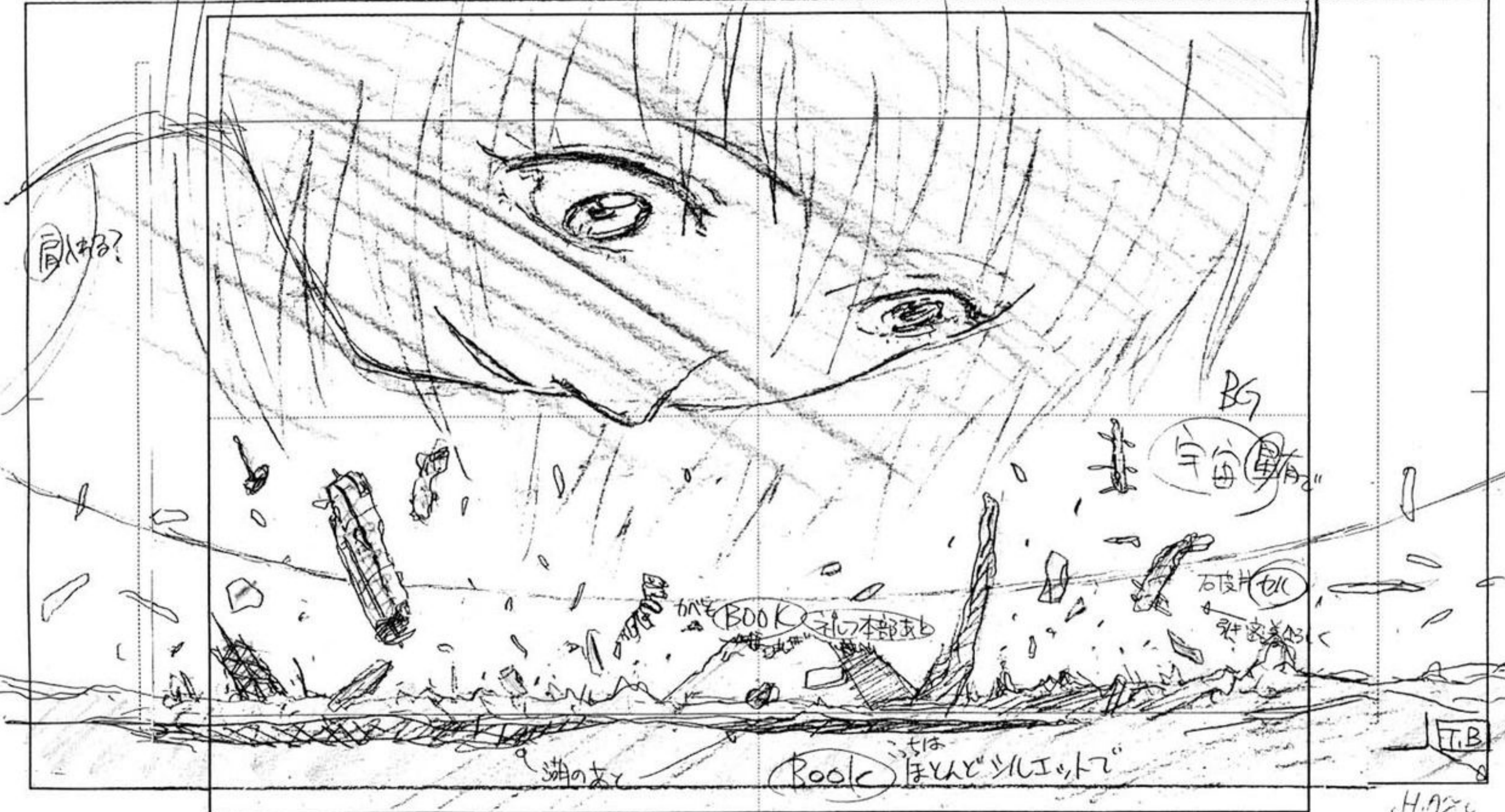

① 招?

BG

宇宙(星)有?

BOOK 本部表

石破(表)

湖の表

Root (は) ほんのシルビエ

FT.B

H.12.6

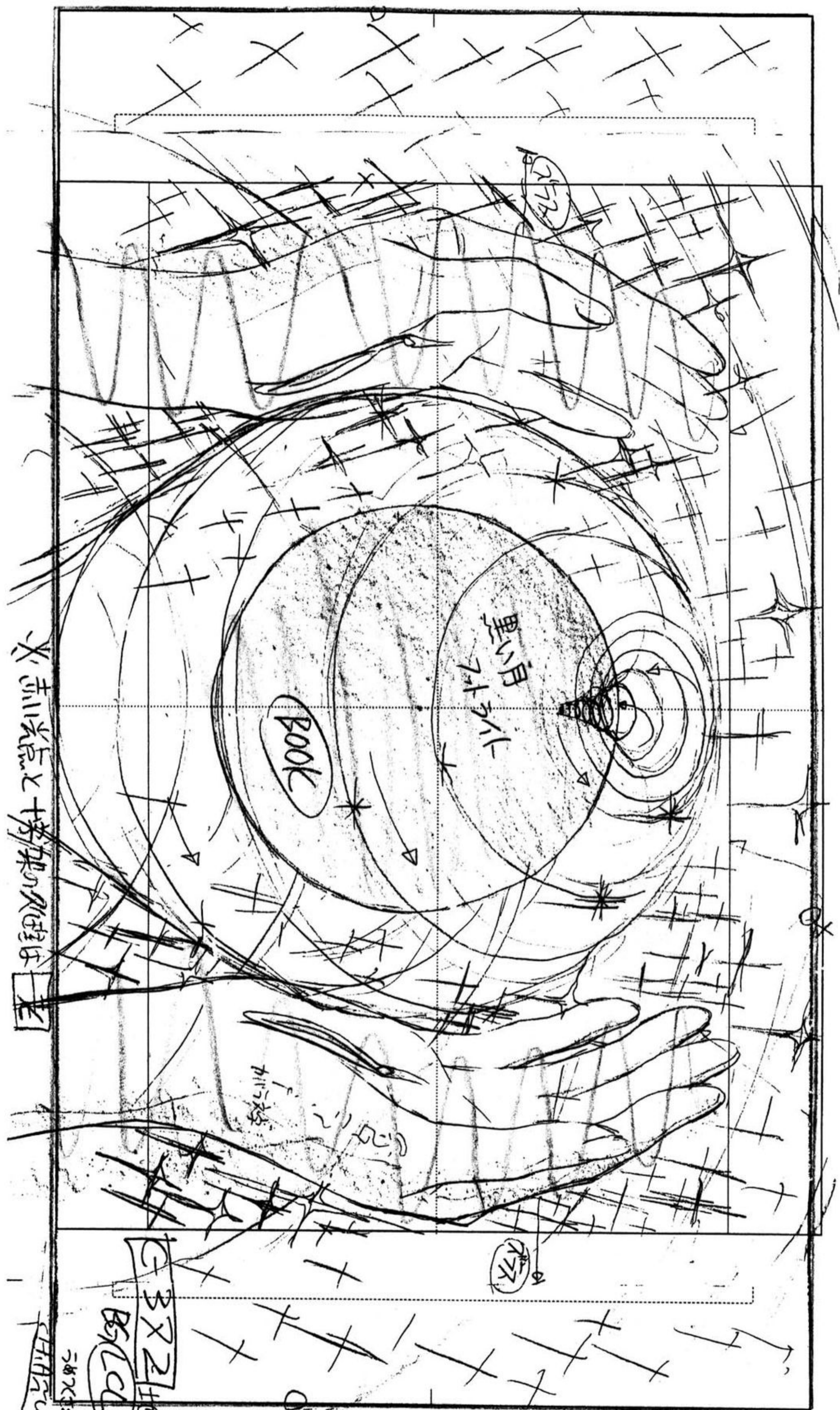

赤い点と塔架の処理は

3721
B5122
赤い点

#26-C316,3721<1>7721

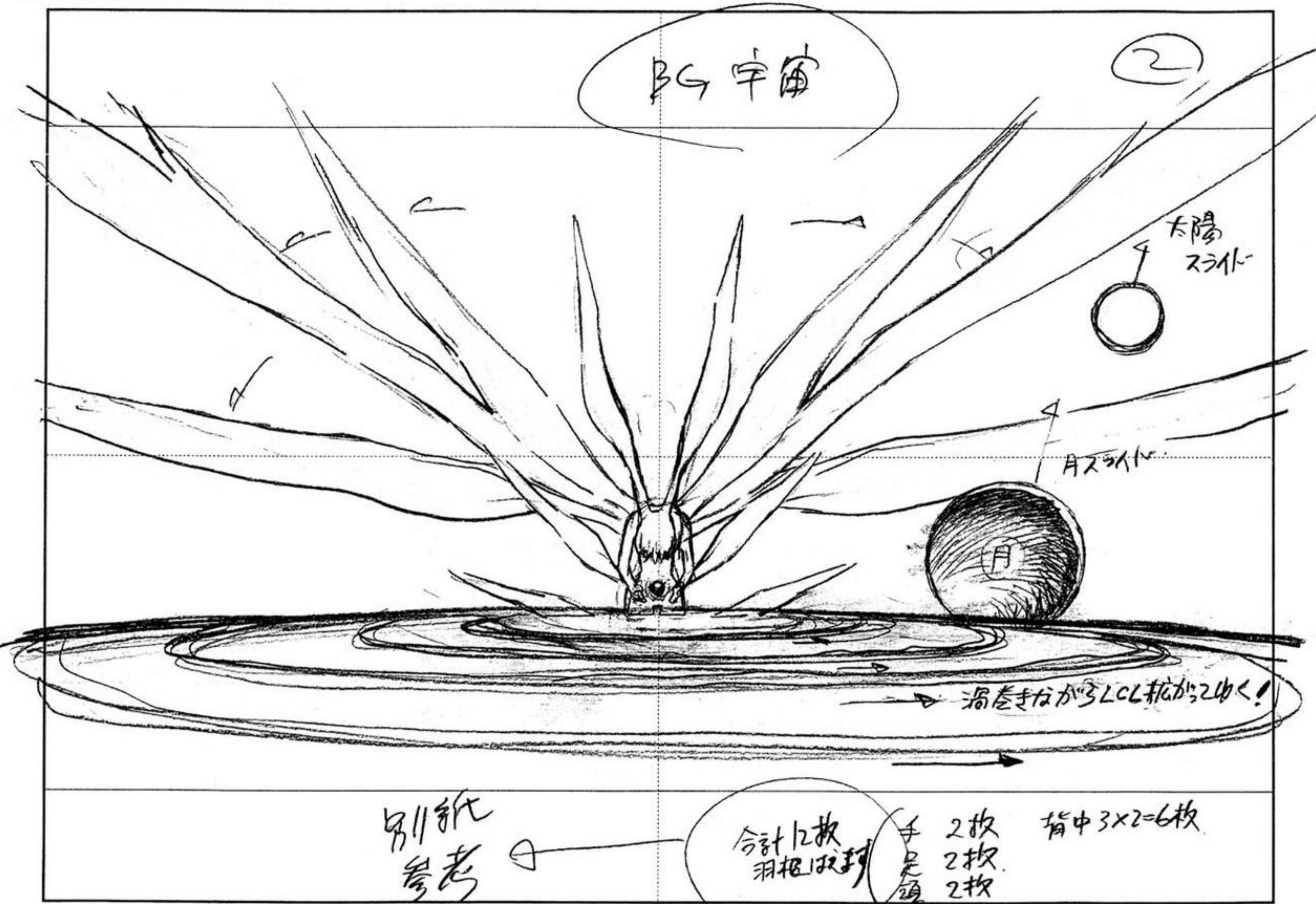

#26-C317レイアウト

ABCDE	1	2	3	4	5
1	2	3	4	5	6
7	8	9	10	11	12
13	14	15	16	17	18
19	20	21	22	23	24
25	26	27	28	29	30
31	32	33	34	35	36

タイムシート

#26-C317

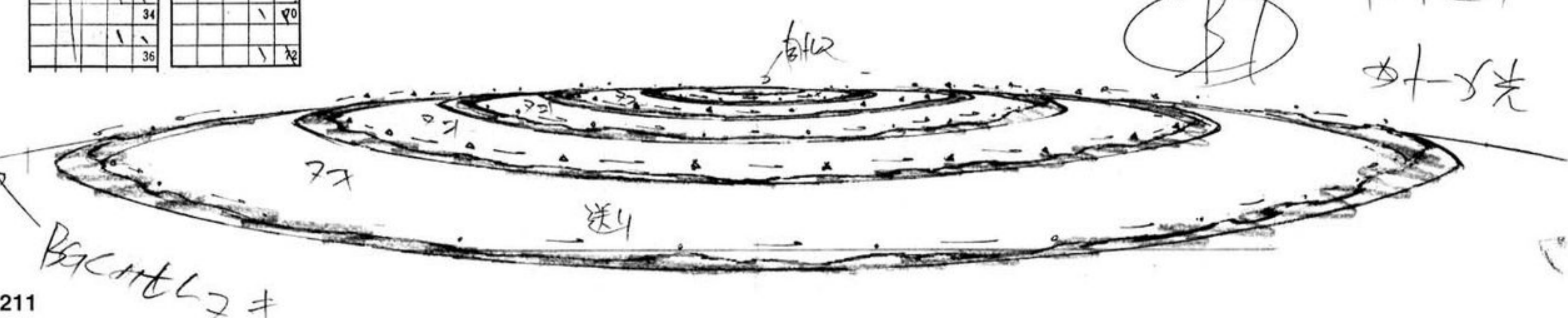



中出し

D1



中出し

Dア



D2



D1

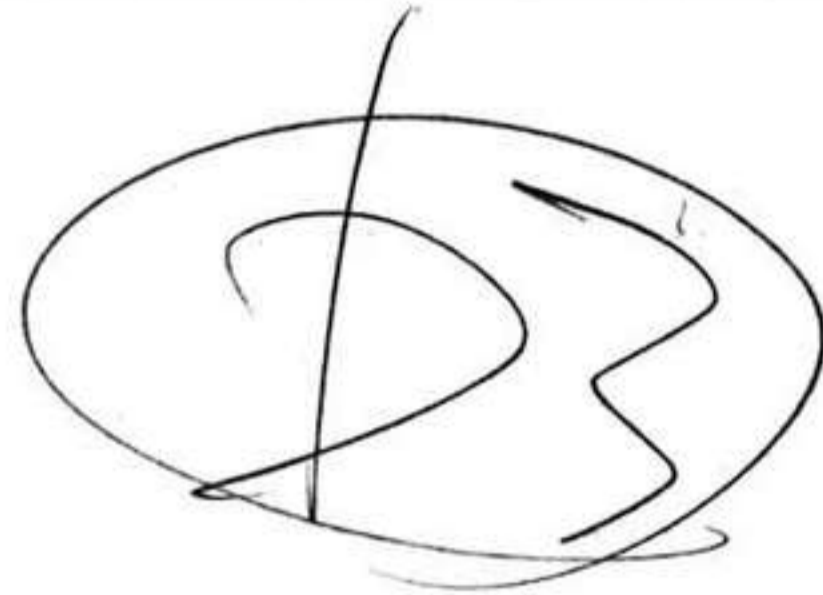

羽根の模 = 中出し
うたから取り部分



中出し

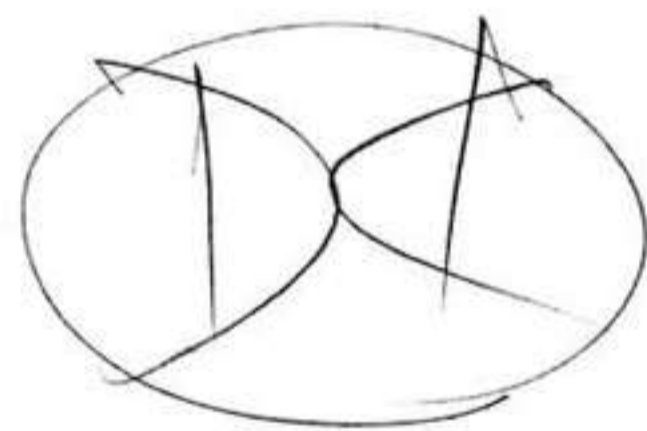

中出し
中出し

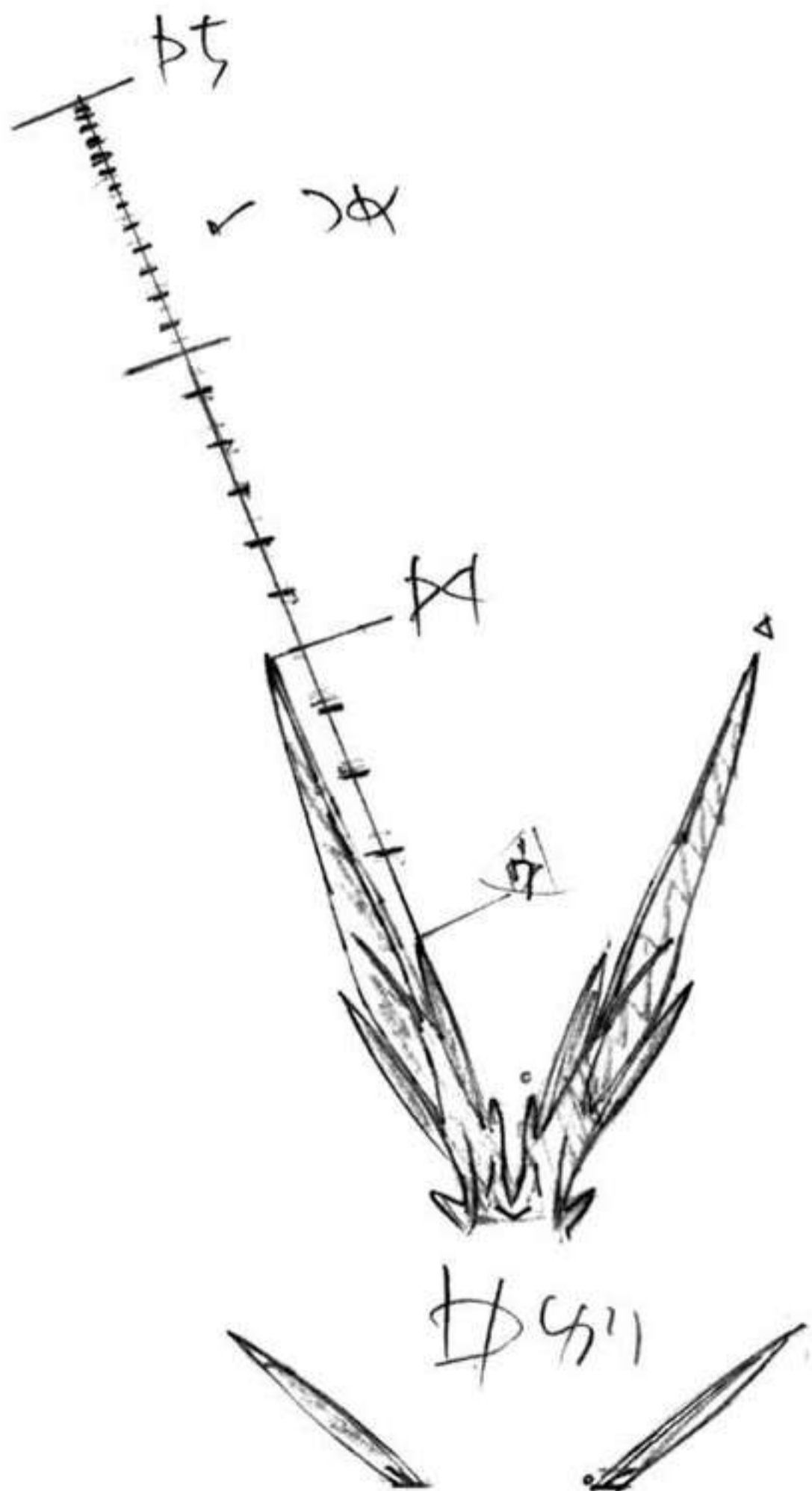

中出し



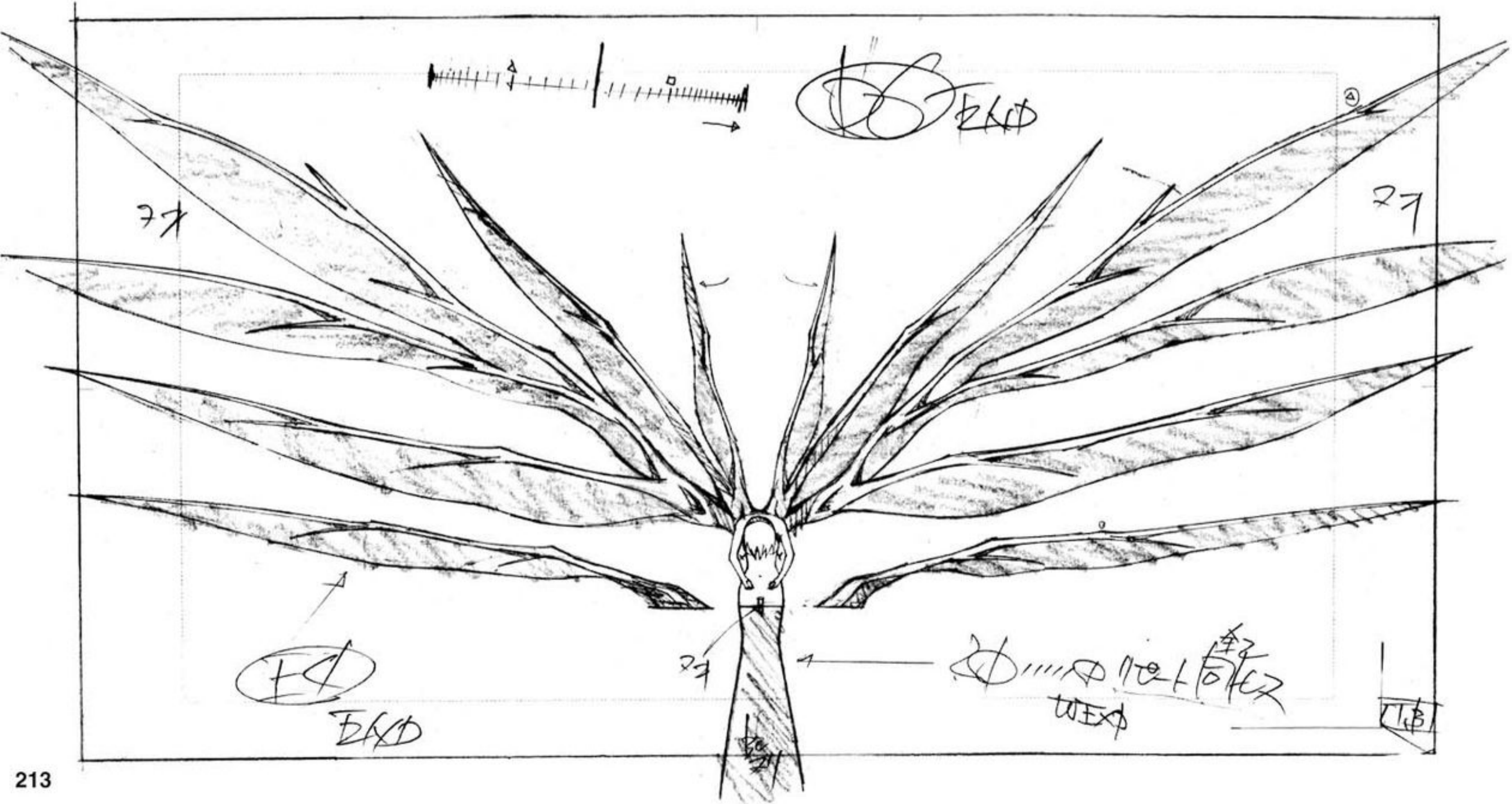
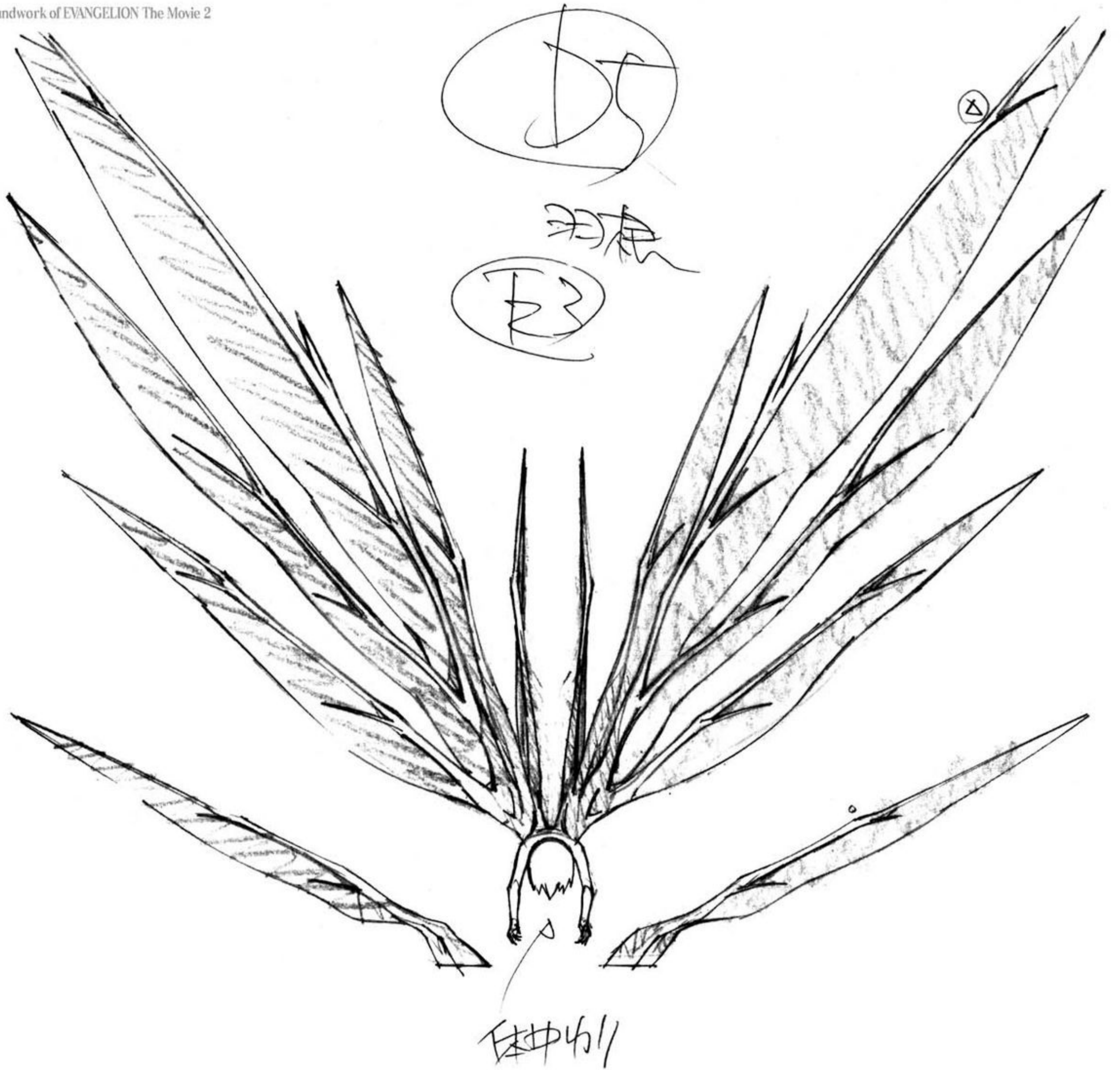

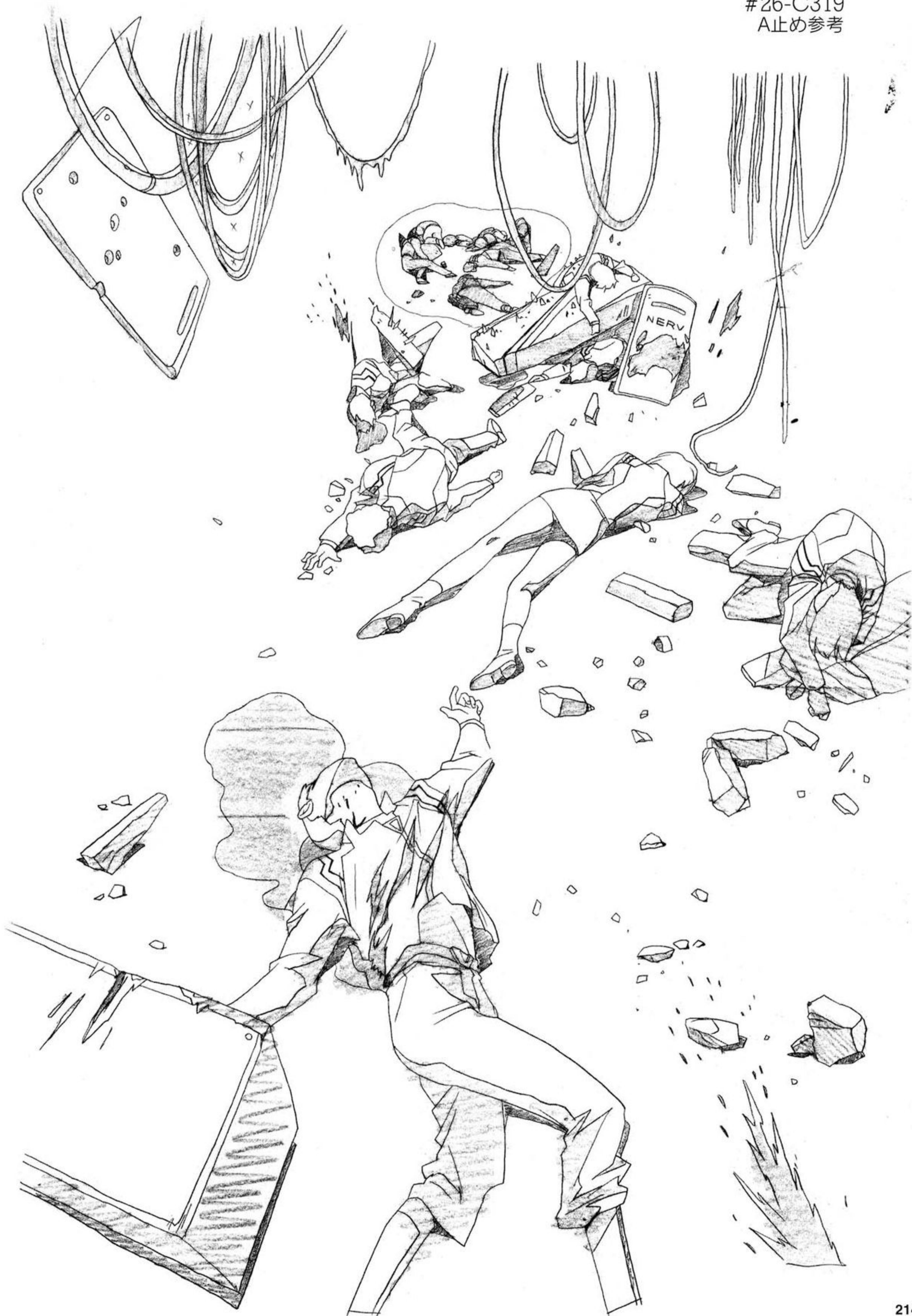

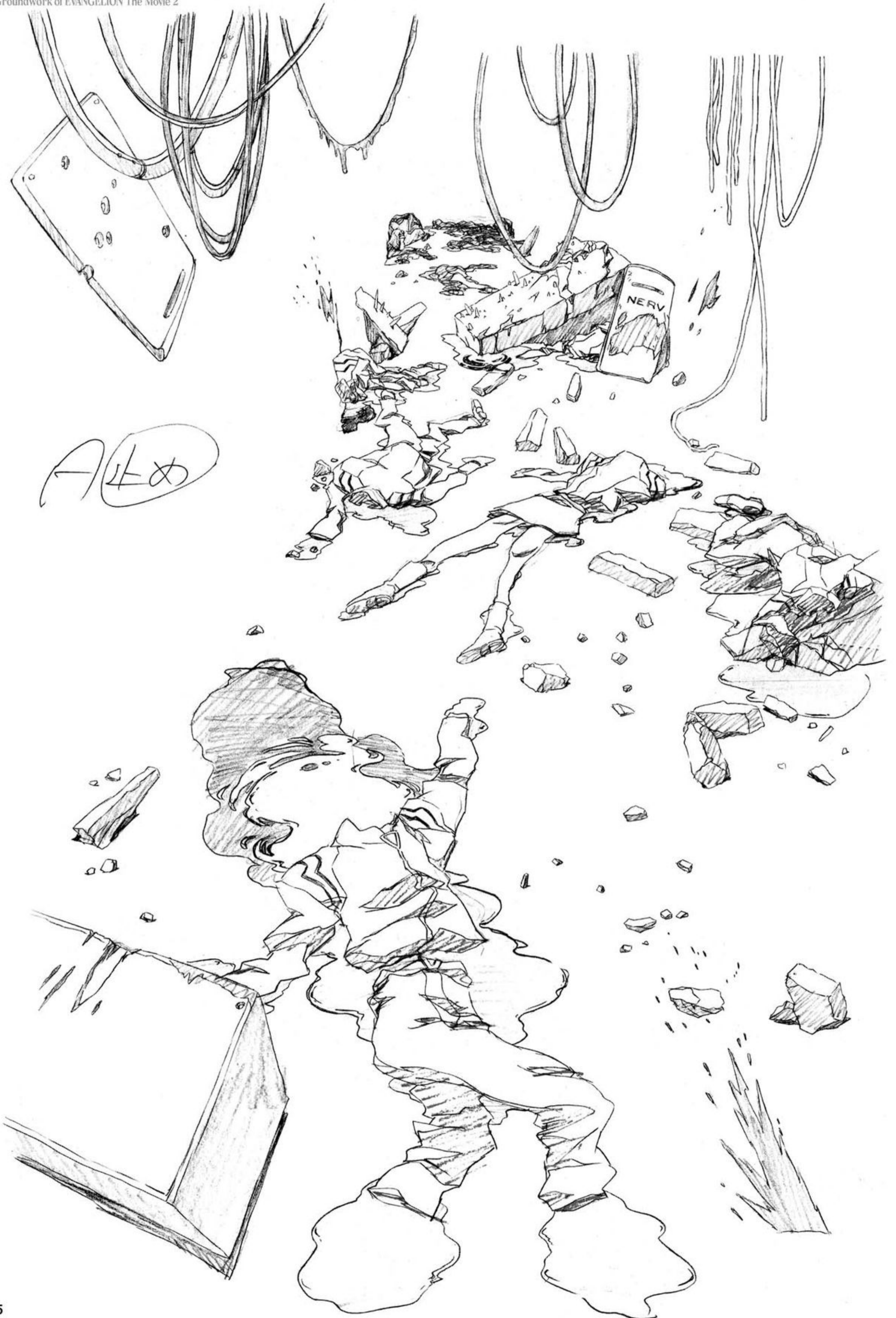

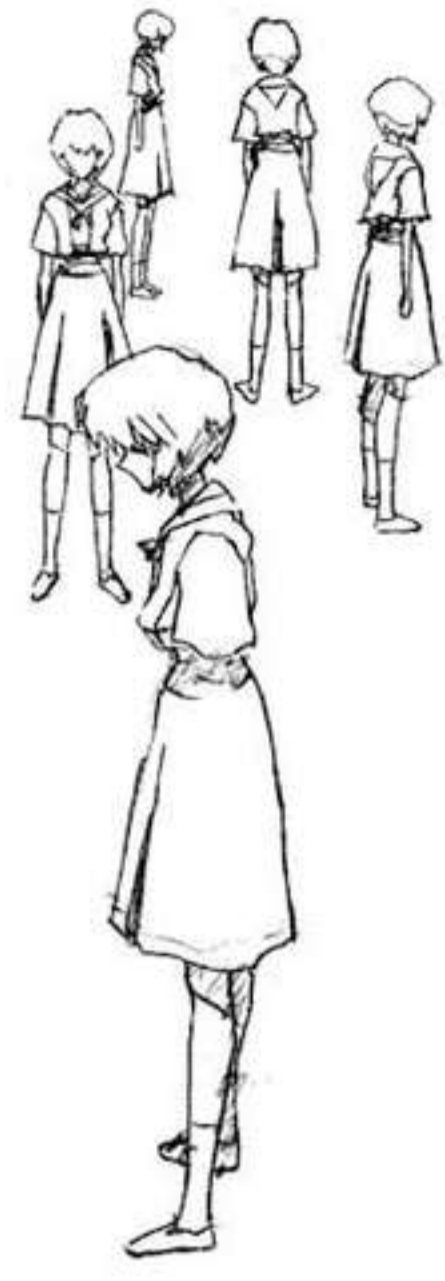

#26-C323





#26-C325

修正原画





修正原画



B1/13



B1



A1

B2



修正原画



B2



修正原画

B4



B3



修正原画

B5



B3



修正原画



修正原画

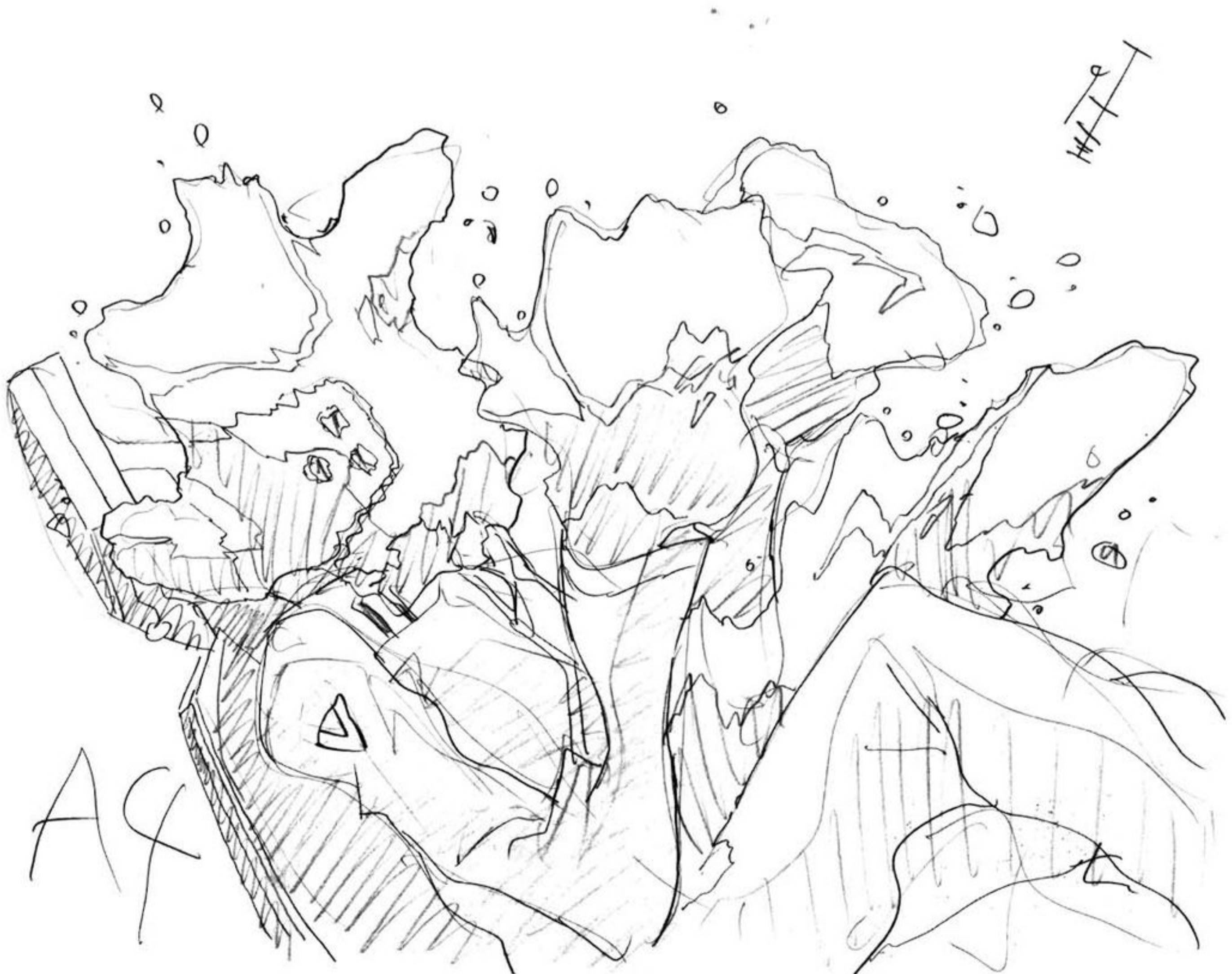
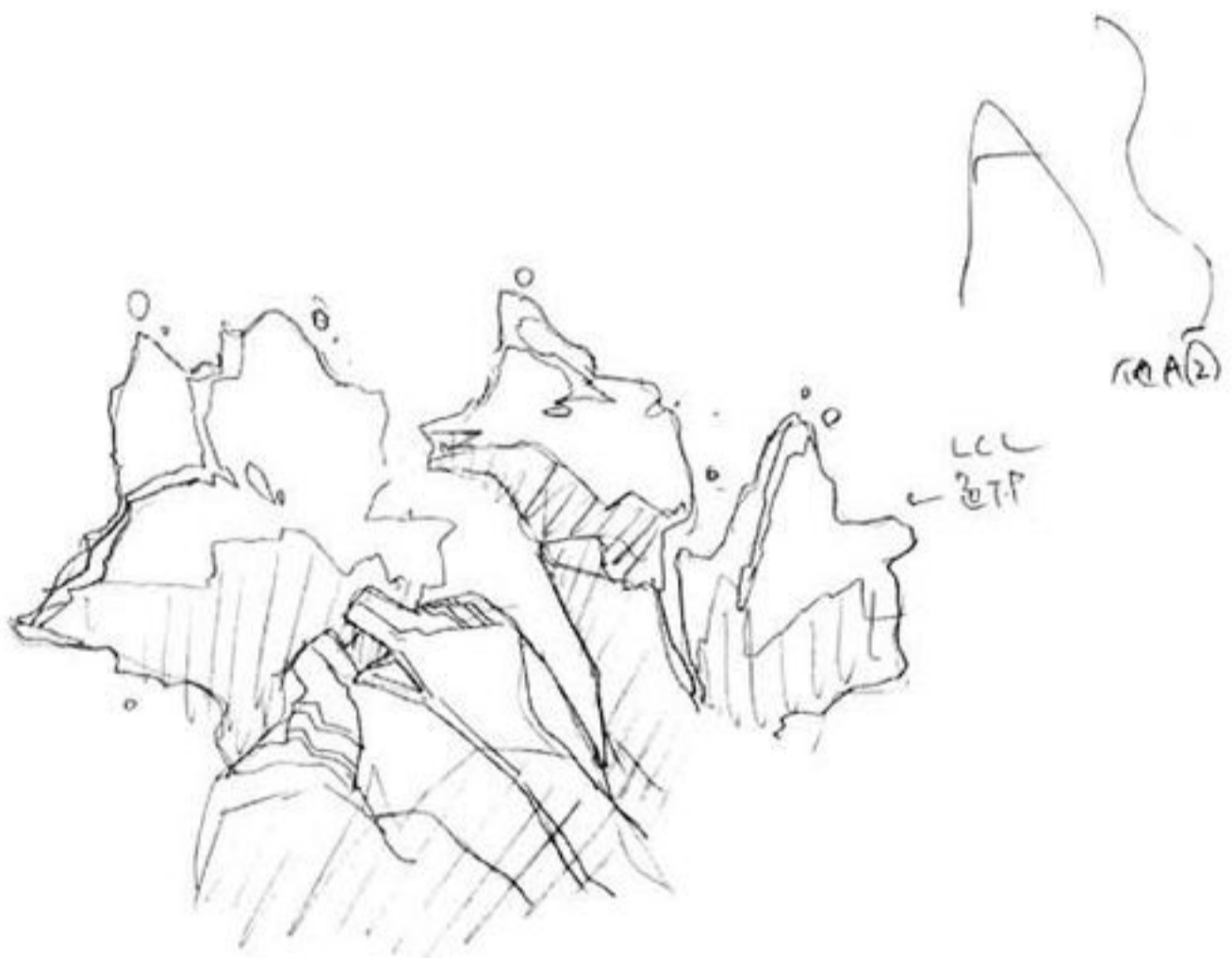
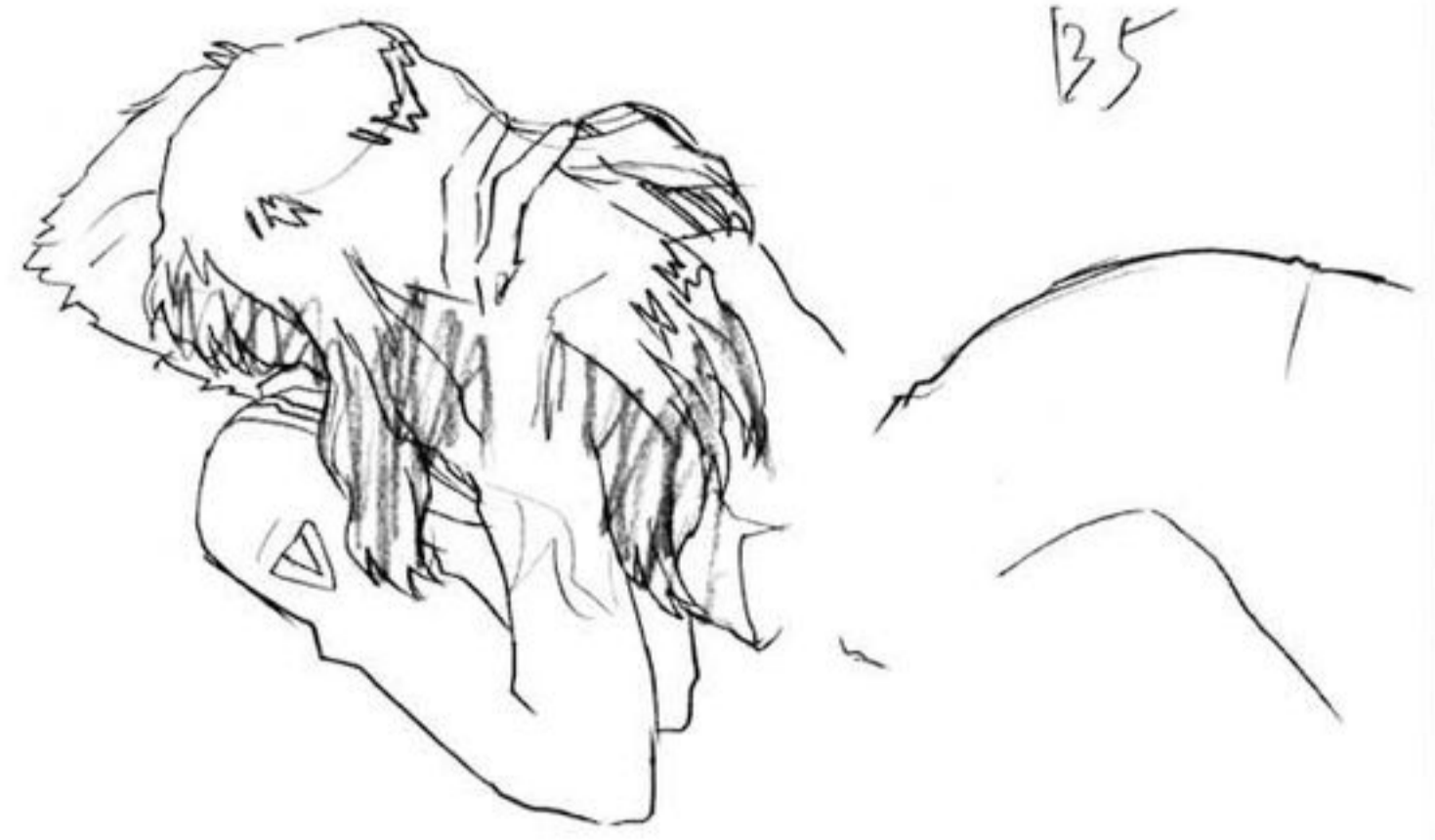



AB			
00			
	2		44
	4		46
	6		48
	8		50
	10		52
	12	(2) (6)	54
	14	(3) X	56
	16		58
	18	(2)	60
	20	X	
	22		
	24		
	26	(3)	
	28		
	30		
	32	(4)	
	34		
	36		
	38	(7)	
	40		
	42		



※動画仕様
 Bセーカ
 カカシ 封
 この赤線 くりおき
 作画して

(A) 修

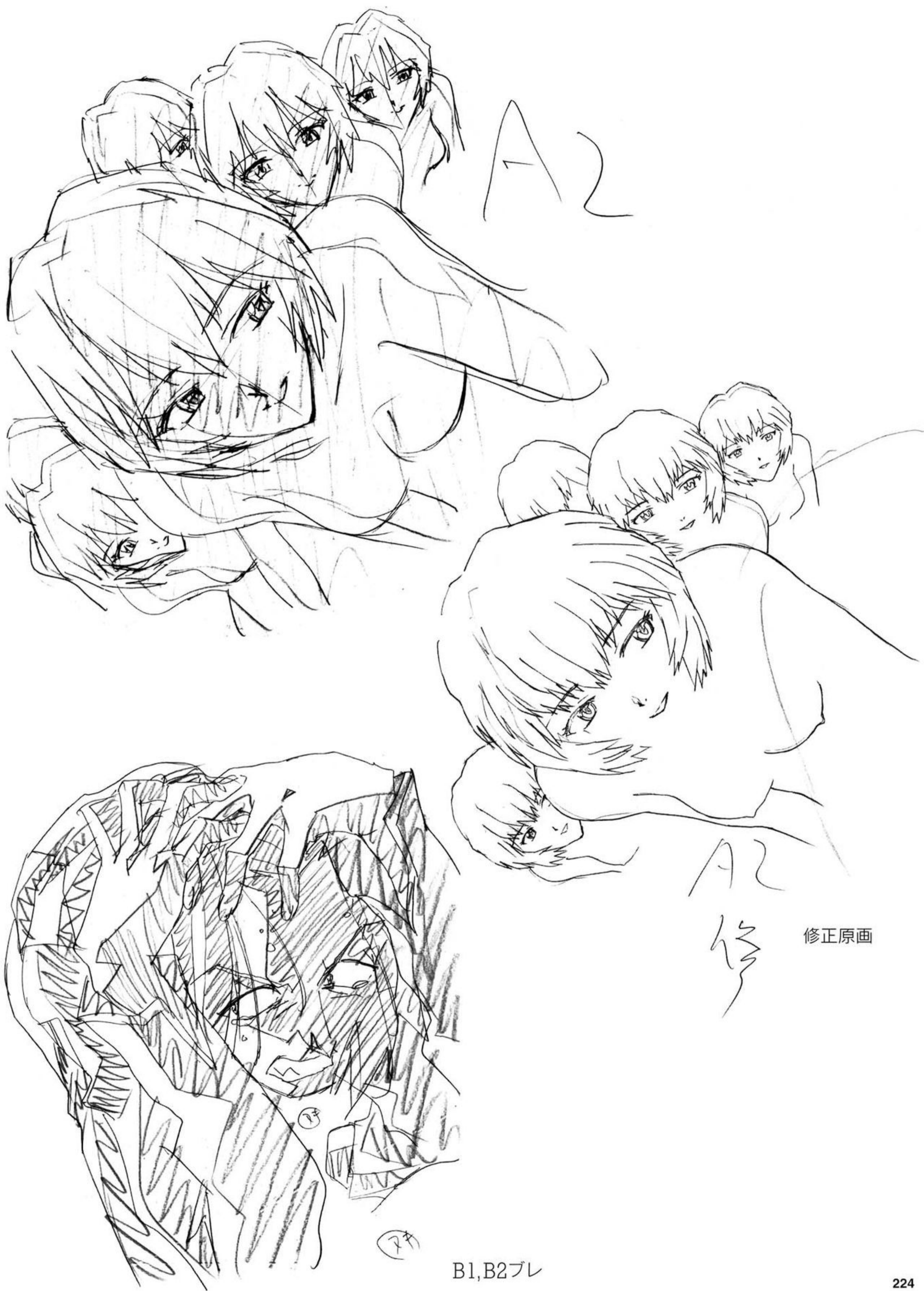

A2

A2

修

修正原画

73

74

B1, B2 プレ



B1,B2ブレ
修正原画



B3,B4ブレ



修正原画

33

A	B	C	
0	0	X	
-2			2
-0			4
-2			6
-0			8
-2			10
-0			12
-2			14
-0			16
-2			18
-0			20
-2			22
-0			24
-1			26
-1			28
-1			30
-1	0		32
-1	1		34
-3	1		36
-4	1		38
-3	1		40
-4	1		42
-3	2		44
-4	1		46
-3	1		48
-4	1		50
-3	1		52
-4	1		54
-3	3		56
-4	1		58
-3	1		60
-4	4		62
-3	3		64
0	5		66
X	X		68
1	1		70
1	6		72

タイムシート

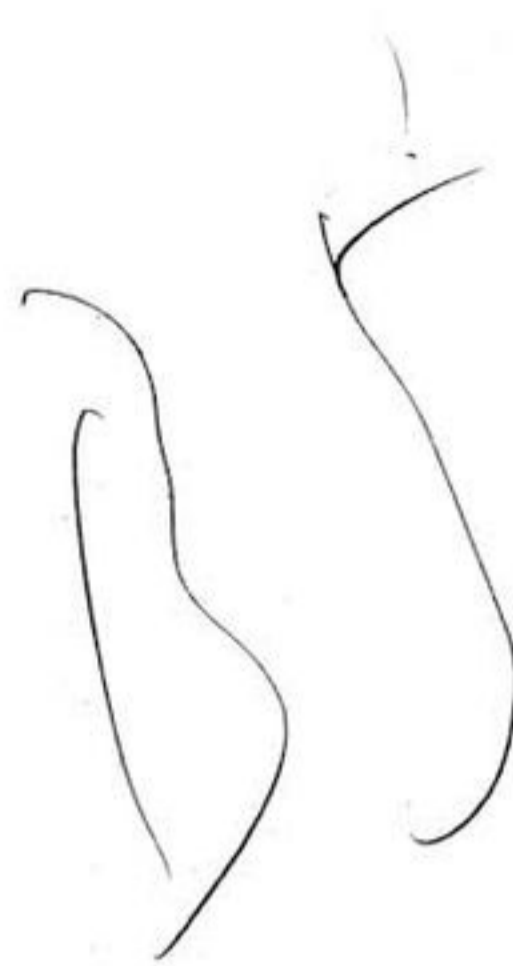

1eB3

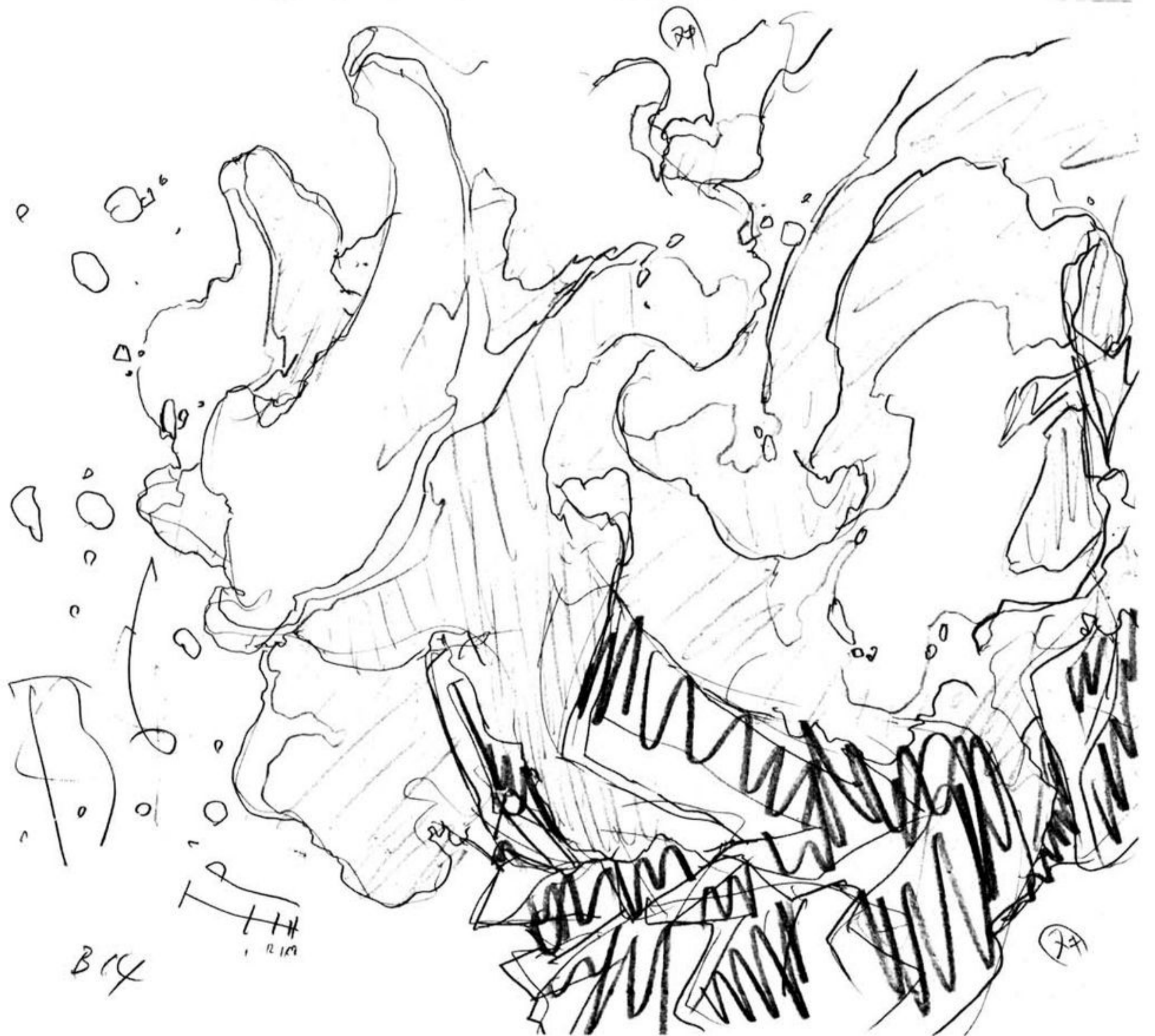

B14

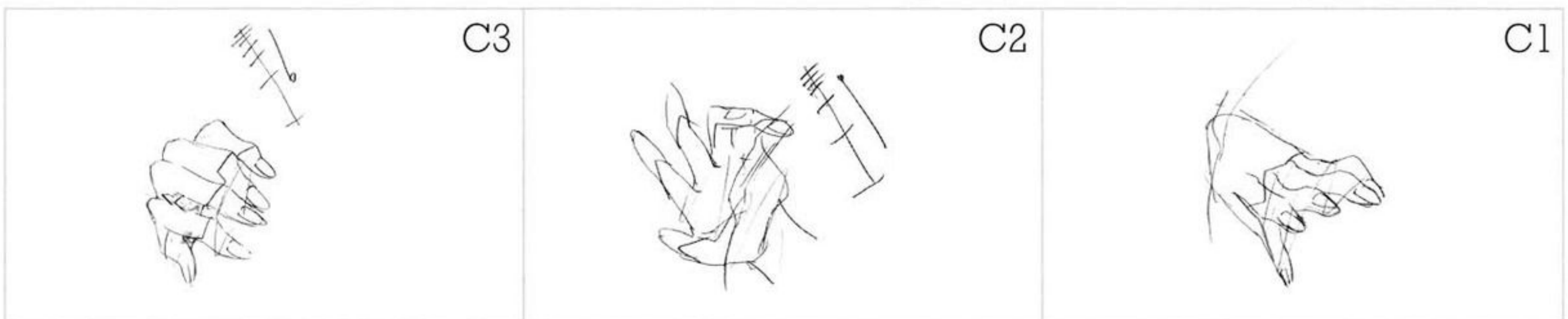
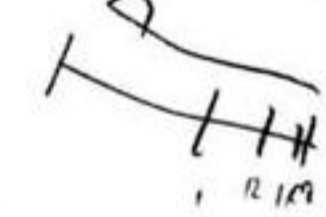

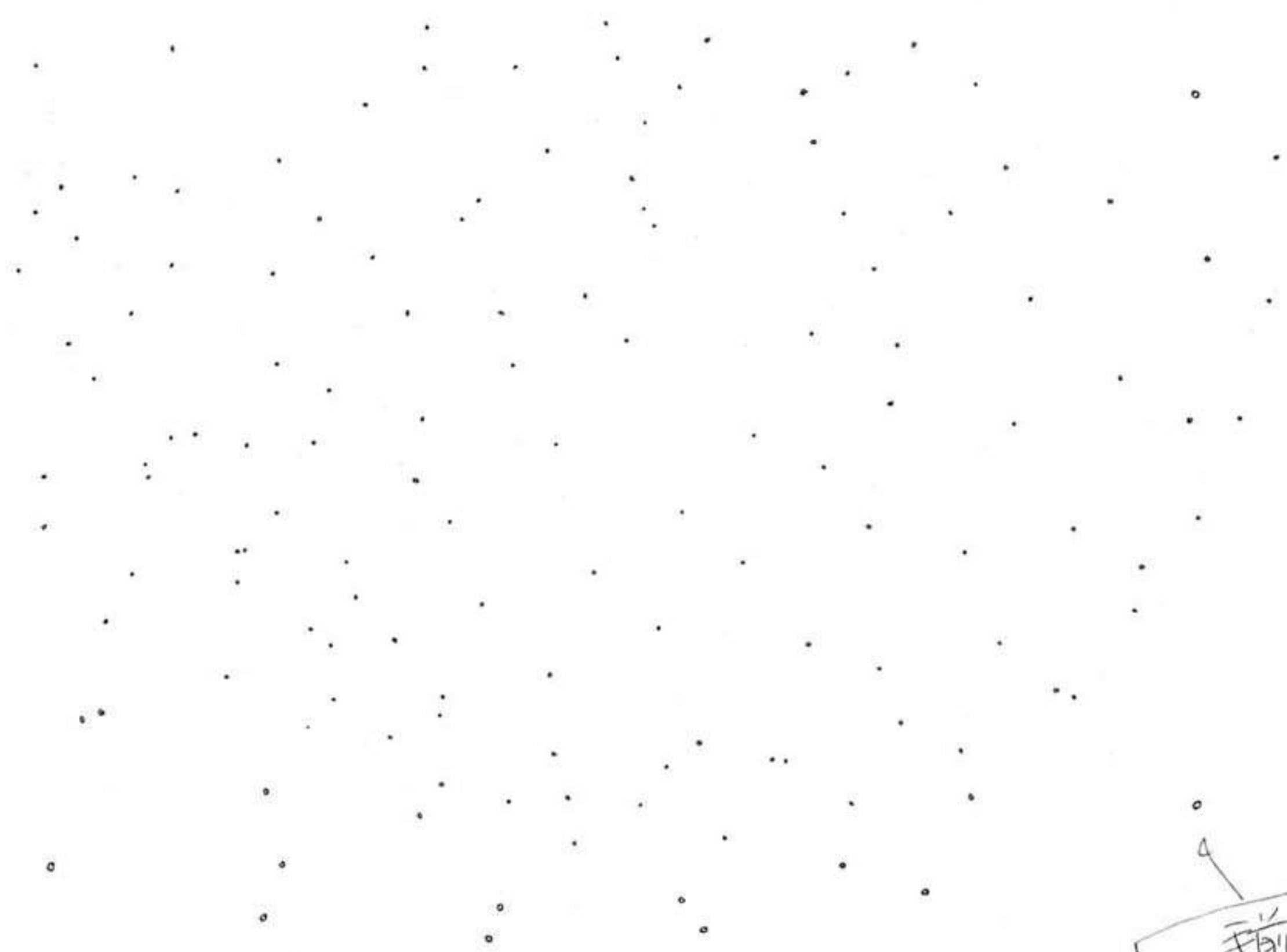

手前の粒は
 大き
 奥に行くとほど
 小さい
 ぞ、よ3し。!

(A) 2345678910111213141516
 リズ外光 AR作画用目盛り合わせ

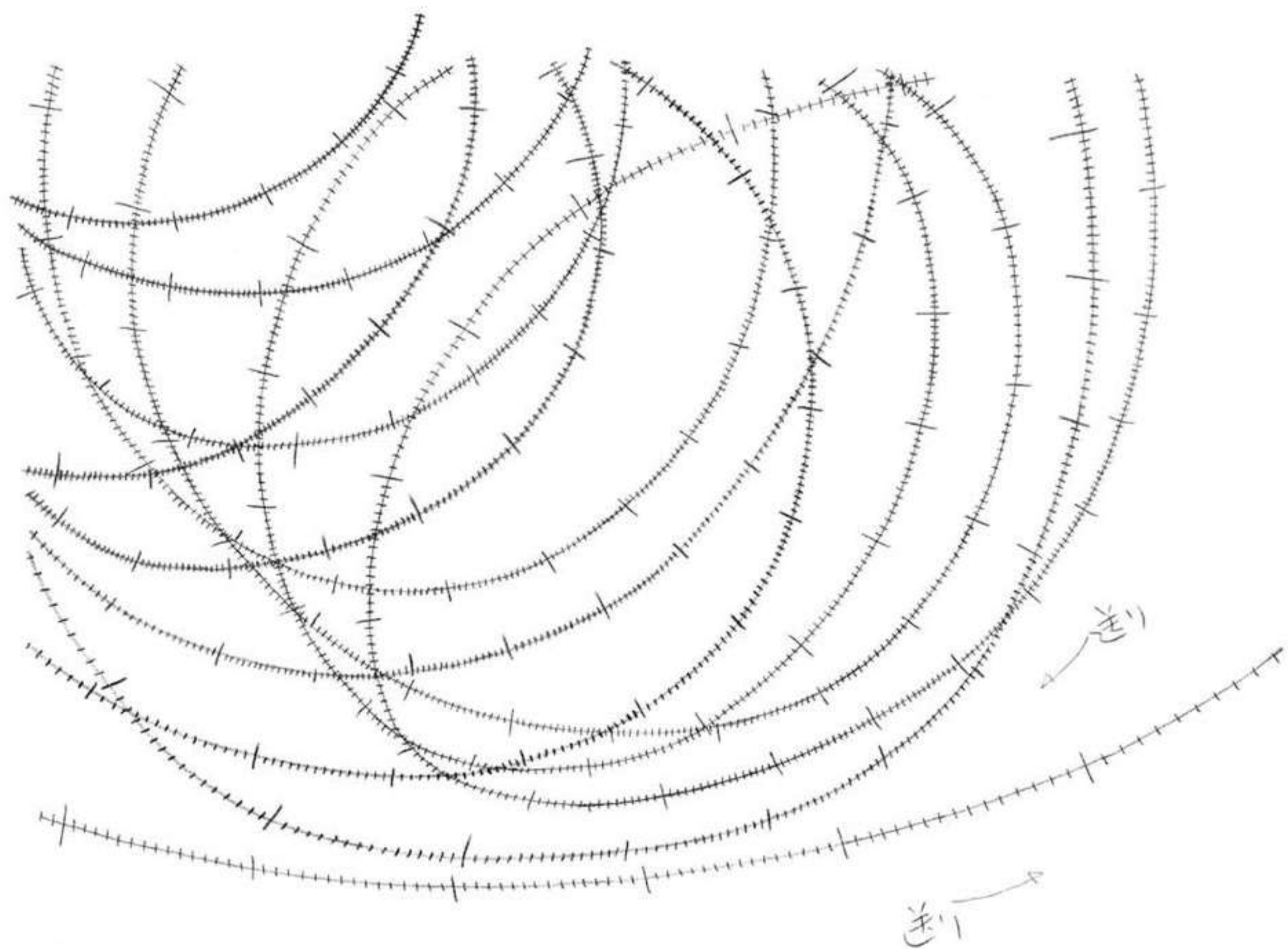

AR作画用目盛り



A1



修正原画



A2



修正原画



A3



修正原画



A4



修正原画

修正原画



B2

B1



修正原画



B3



修正原画



C1

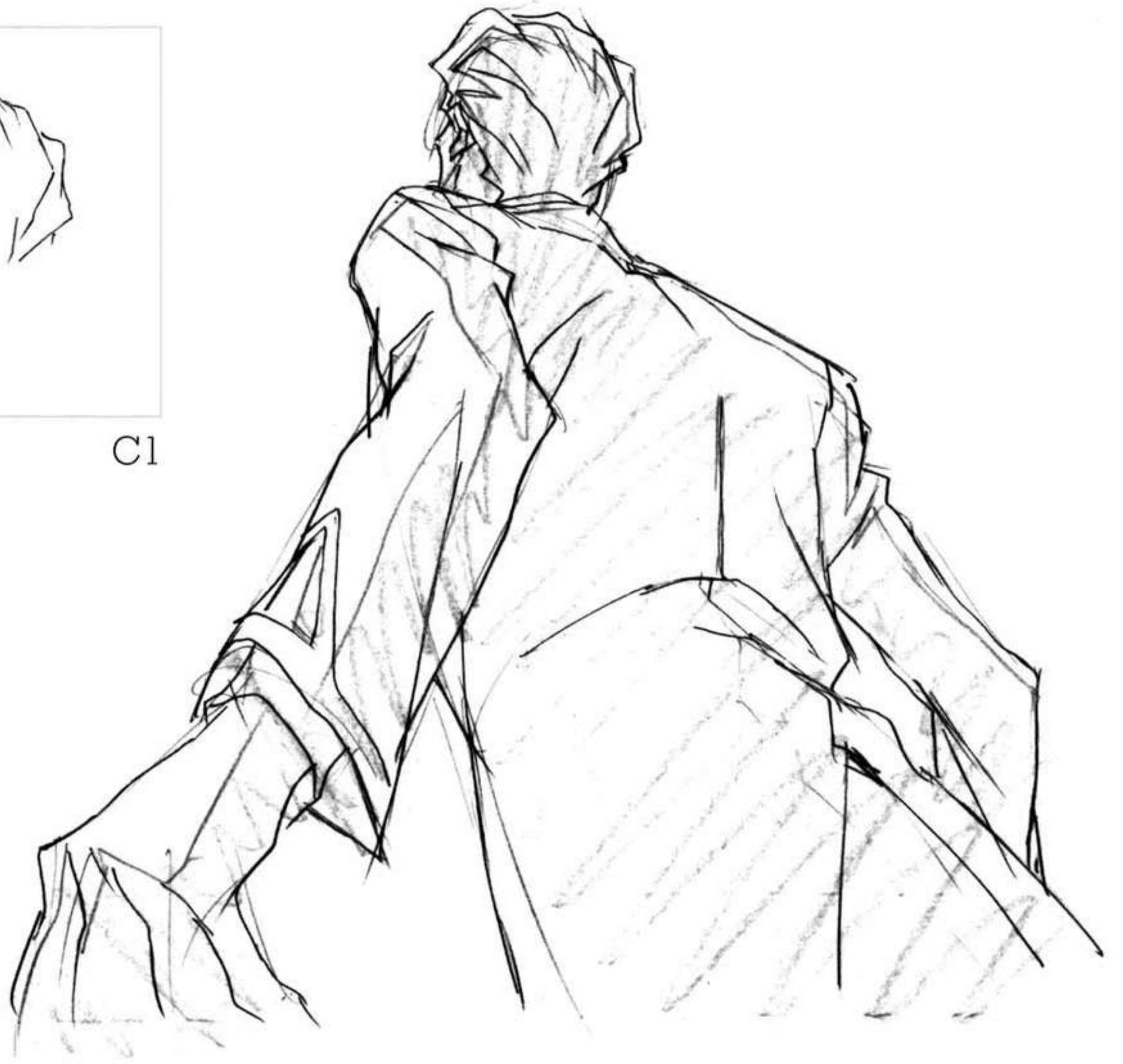

C2



A	ABC	
1	DXO	
2		
3		
4		
5		
6		
7		
8		
9		
10		
11		
12		
13		
14		
15		
16		
17	②	
18		
19		
20		
21		
22		
23		
24		
25		
26		
27		
28		
29		
30		
31	③	
32		
33		
34		
35		
36		
37		
38		
39		
40		
41		
42		
43	②④③	
44		
45	X	
46		
47		
48		
49		
50		
51		
52		
53		
54	③	
55		
56		
57	③ X	
58		
59		
60		
61		
62	F	

タイムシート

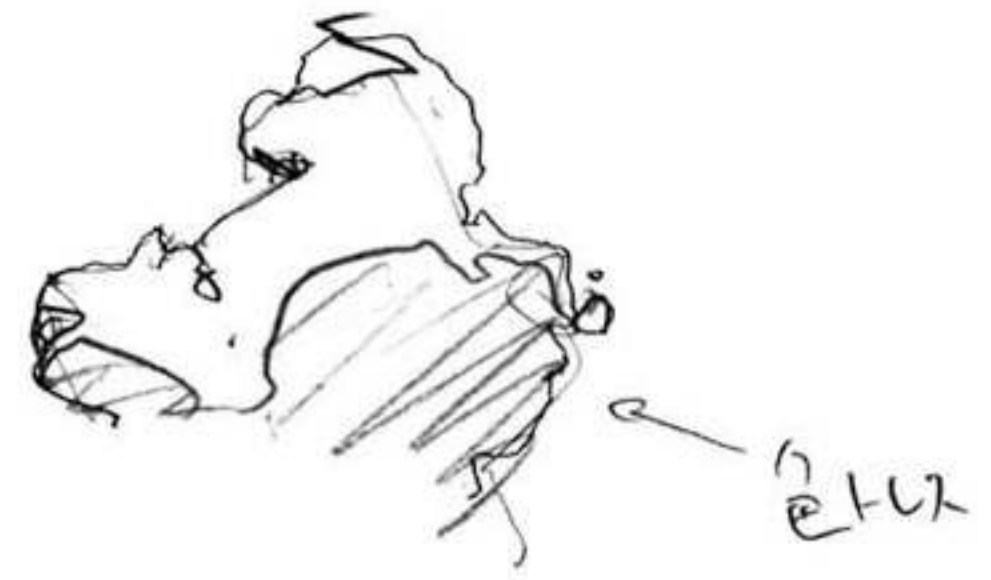
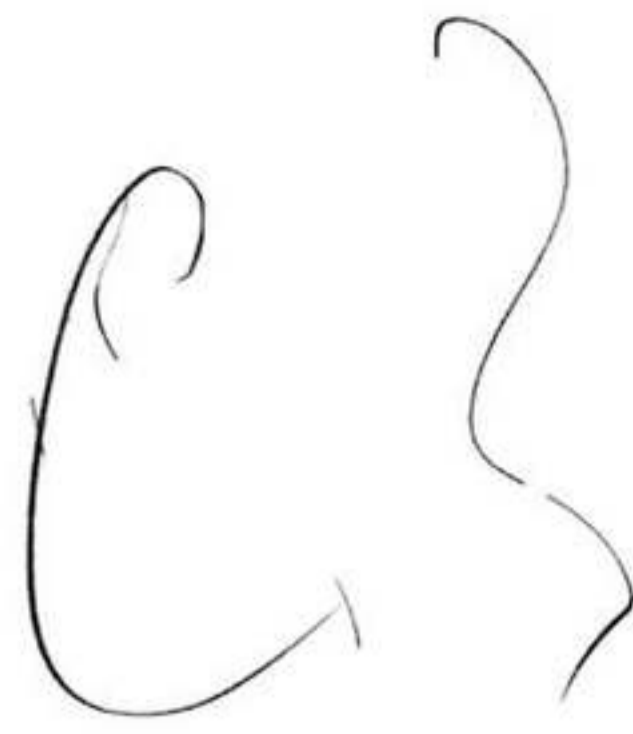

1. ② C2.

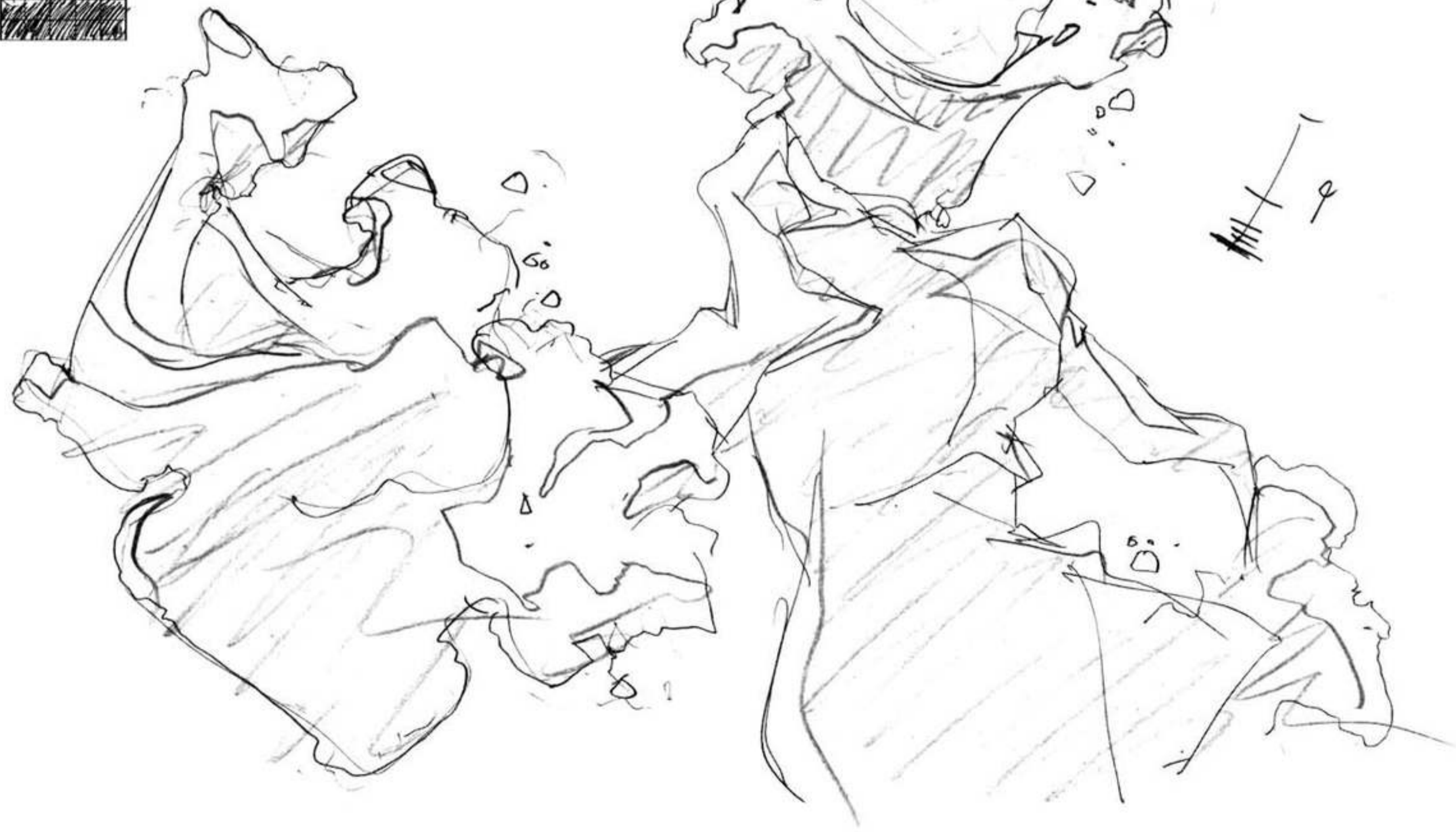
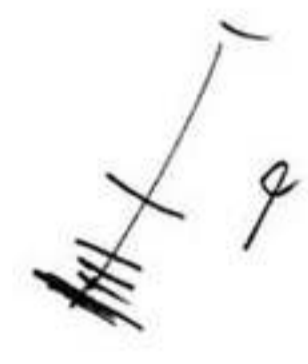
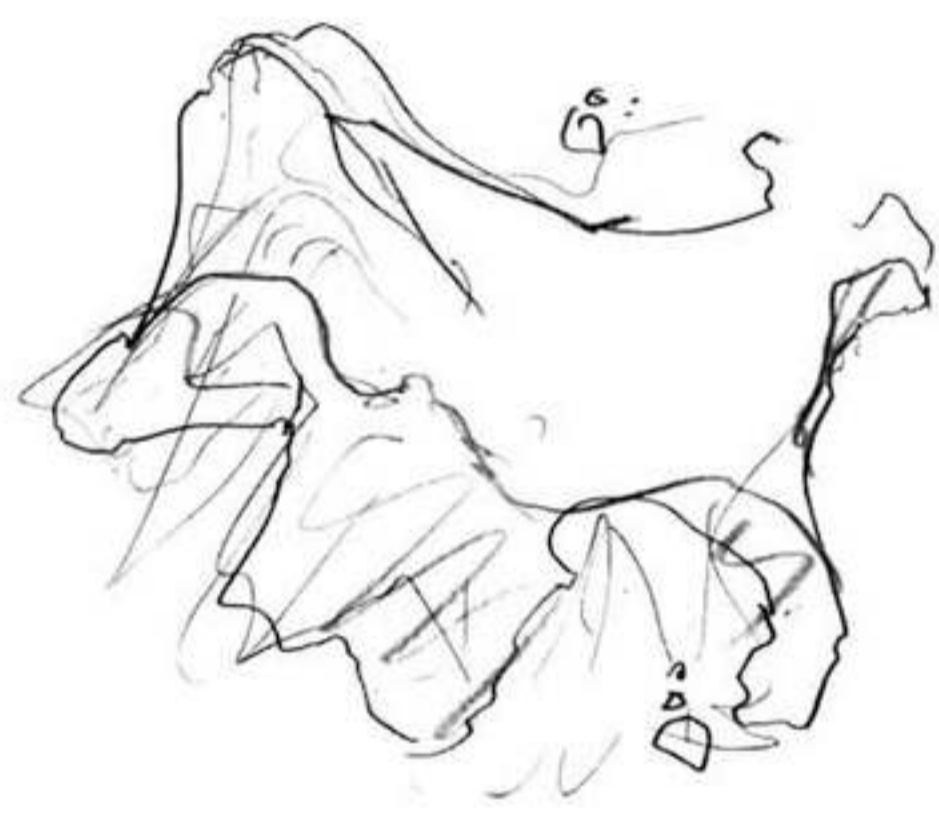

B1

0113
C D 23

又#



B2

1143
ク7000
OL
TP

白元





次で〜
肩を握る(中つれいれり)



4-5
B(1)



B5

75-6



B6



リリコの手を
握る

#26-C333,335

(A1)



リリコの手を
握る

A
1-2
リリコの手を
握る

(A2)



リリコの手を
握る

リリコの手を
握る



1世 (A2) HV2

(A3)



(A1)

(A0)

A4
17" (HV2)



17" の
投影

20" の
投影
17" の
投影

20" の



タイムシート

1	2
1	4
1	6
2	8
1	10
1	12
3	14
1	16
1	18
1	20
1	22
1	24
1	26
1	28
1	30
1	32
1	34
1	36
1	38
1	40
1	42
1	44
1	46
1	48
1	50

A4



A5





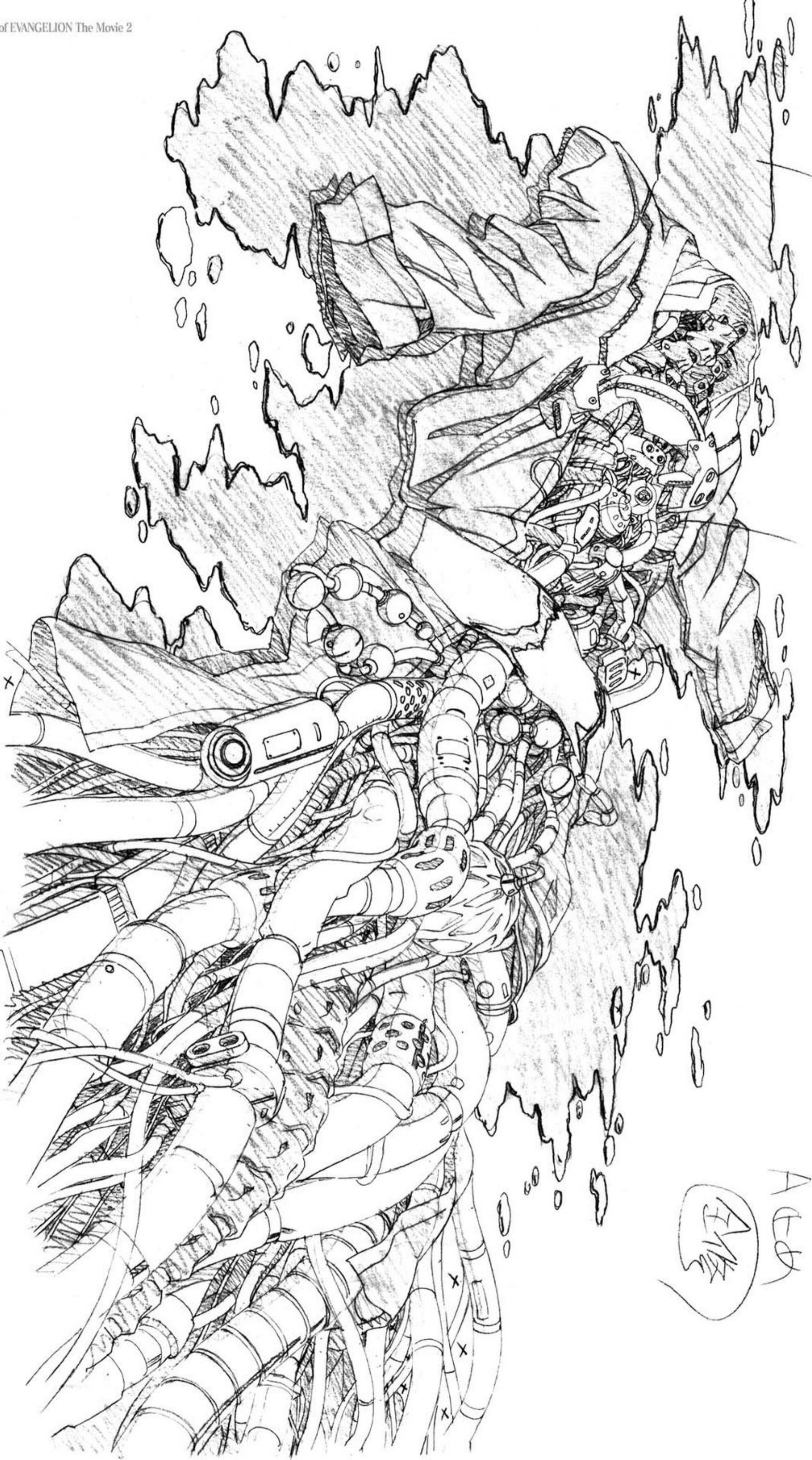

UL 色(白)

九三三(規格1211)

AEDX
△修

#26-C342



A1

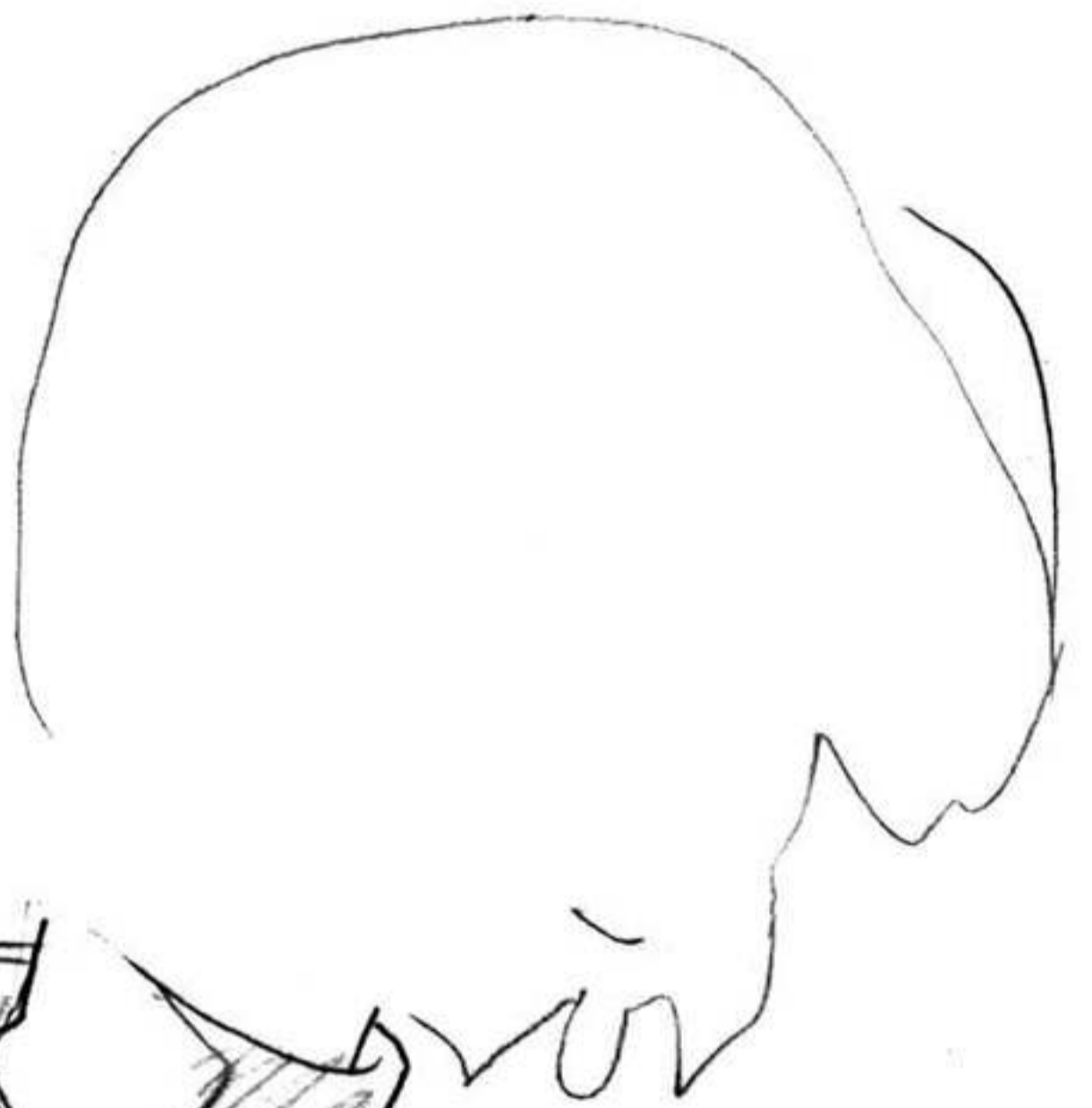

77(A)
1422

B(1)
3

A2



#26-C348,354

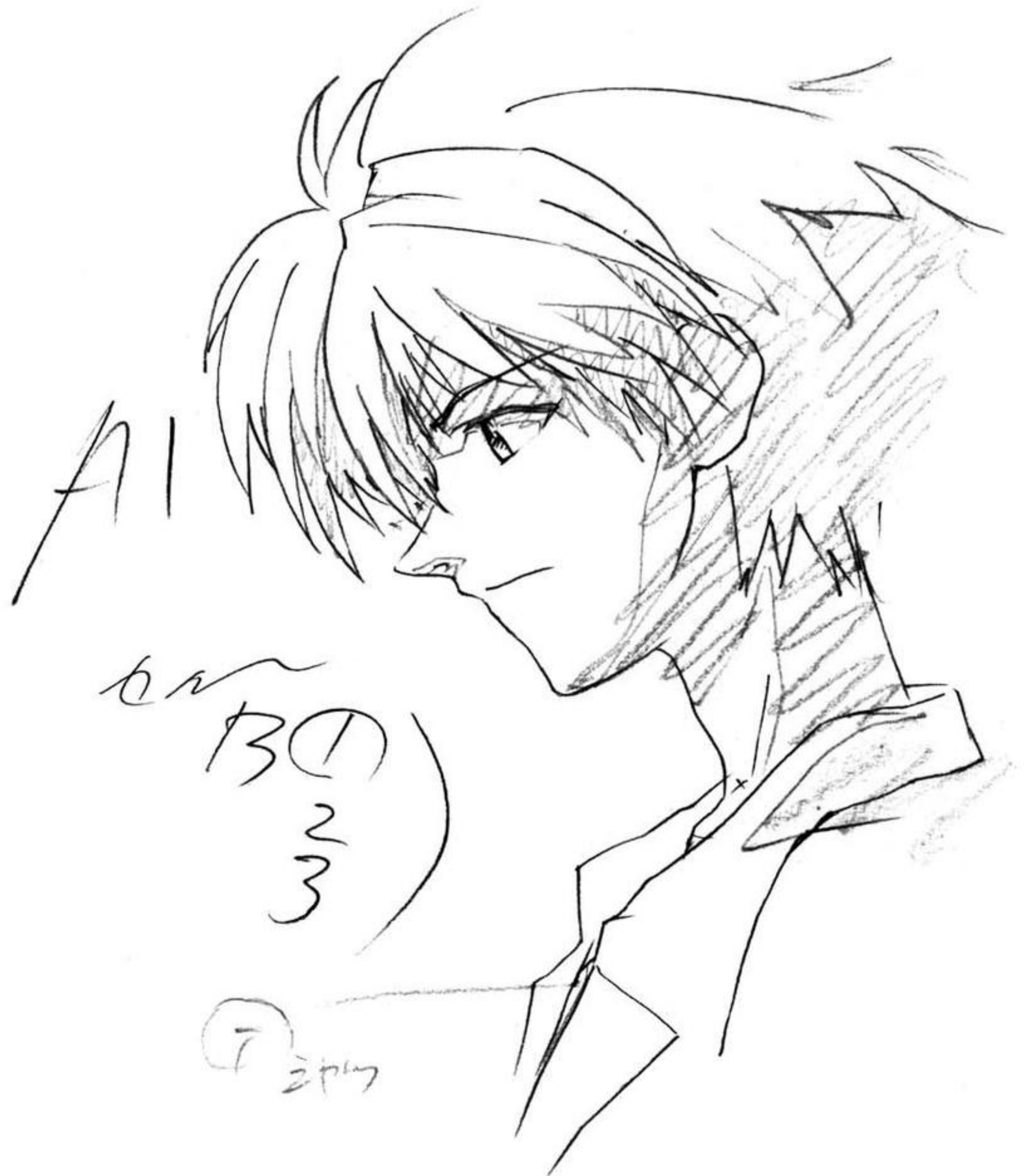

#26-C352

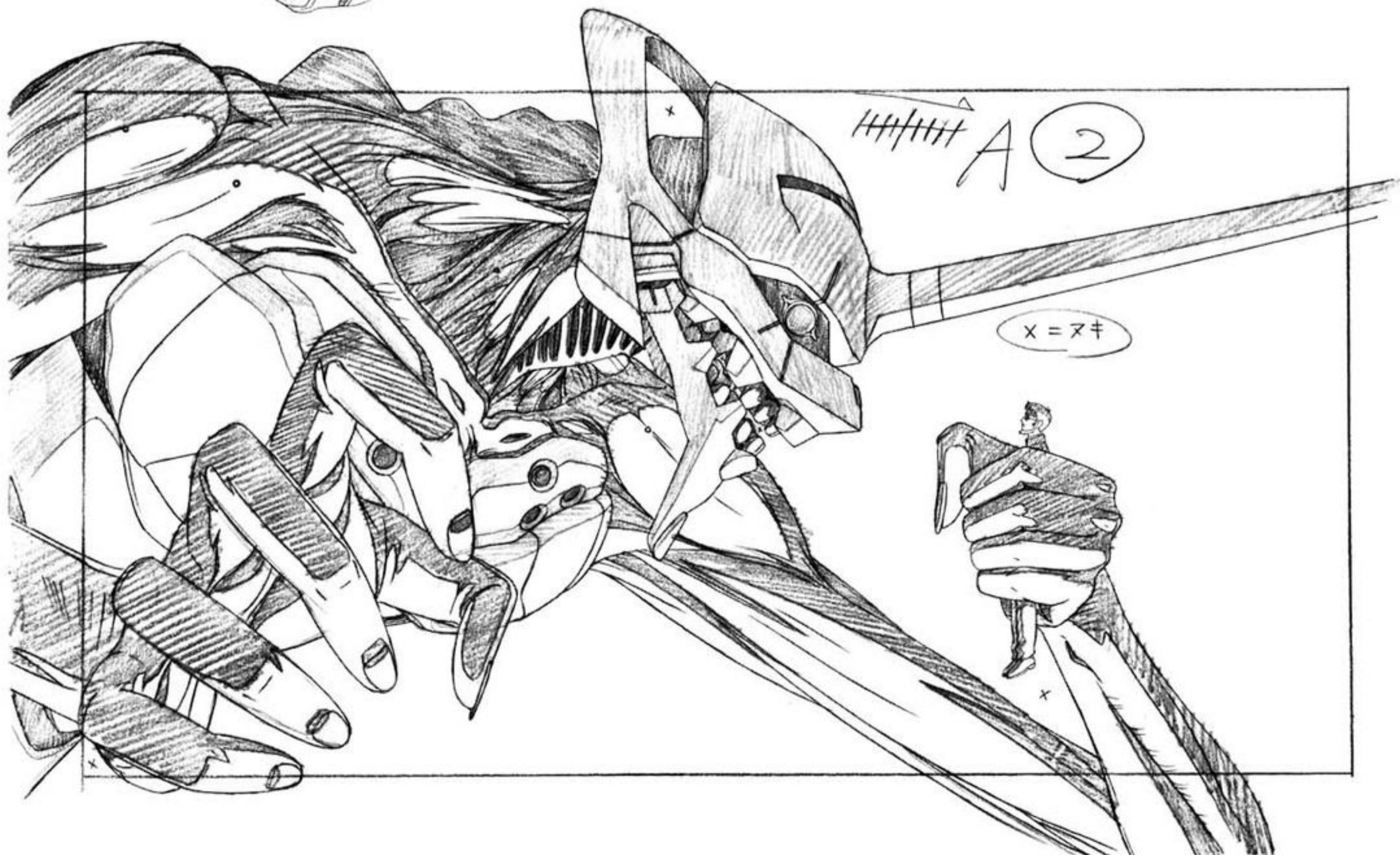
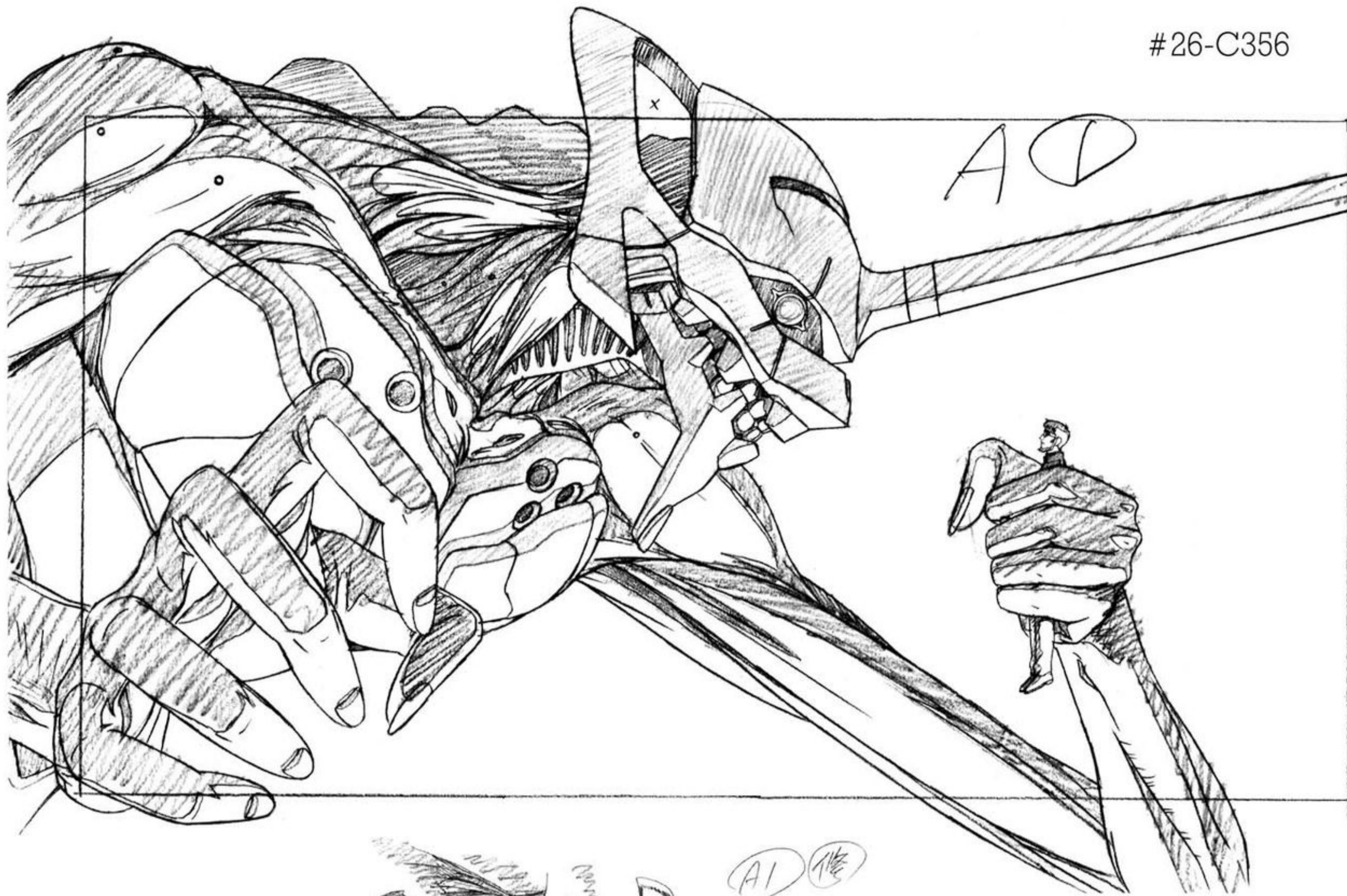



A2 (修)



修正原画

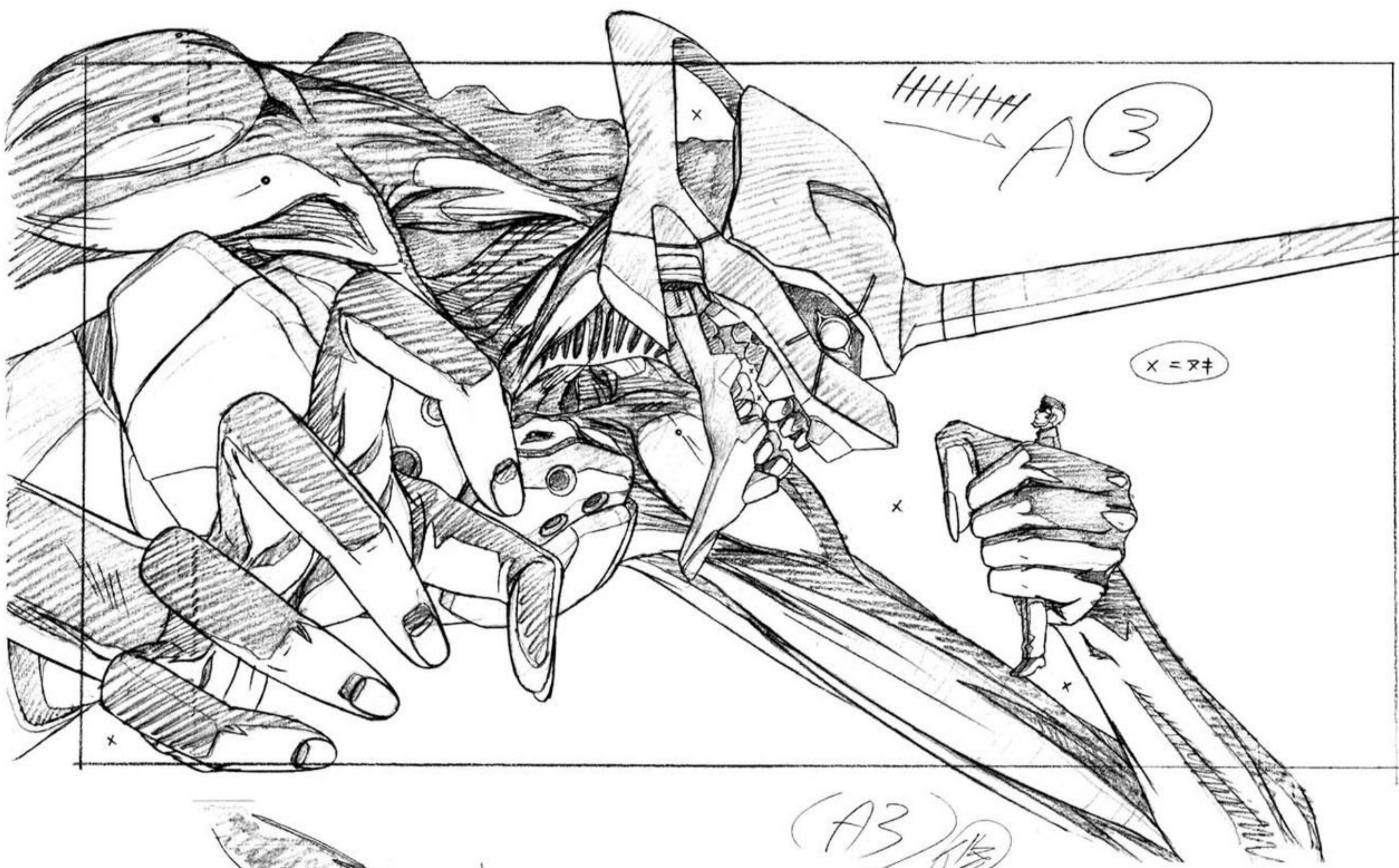

HHHHH → A3 (修)

x = x#

(A3) (修)

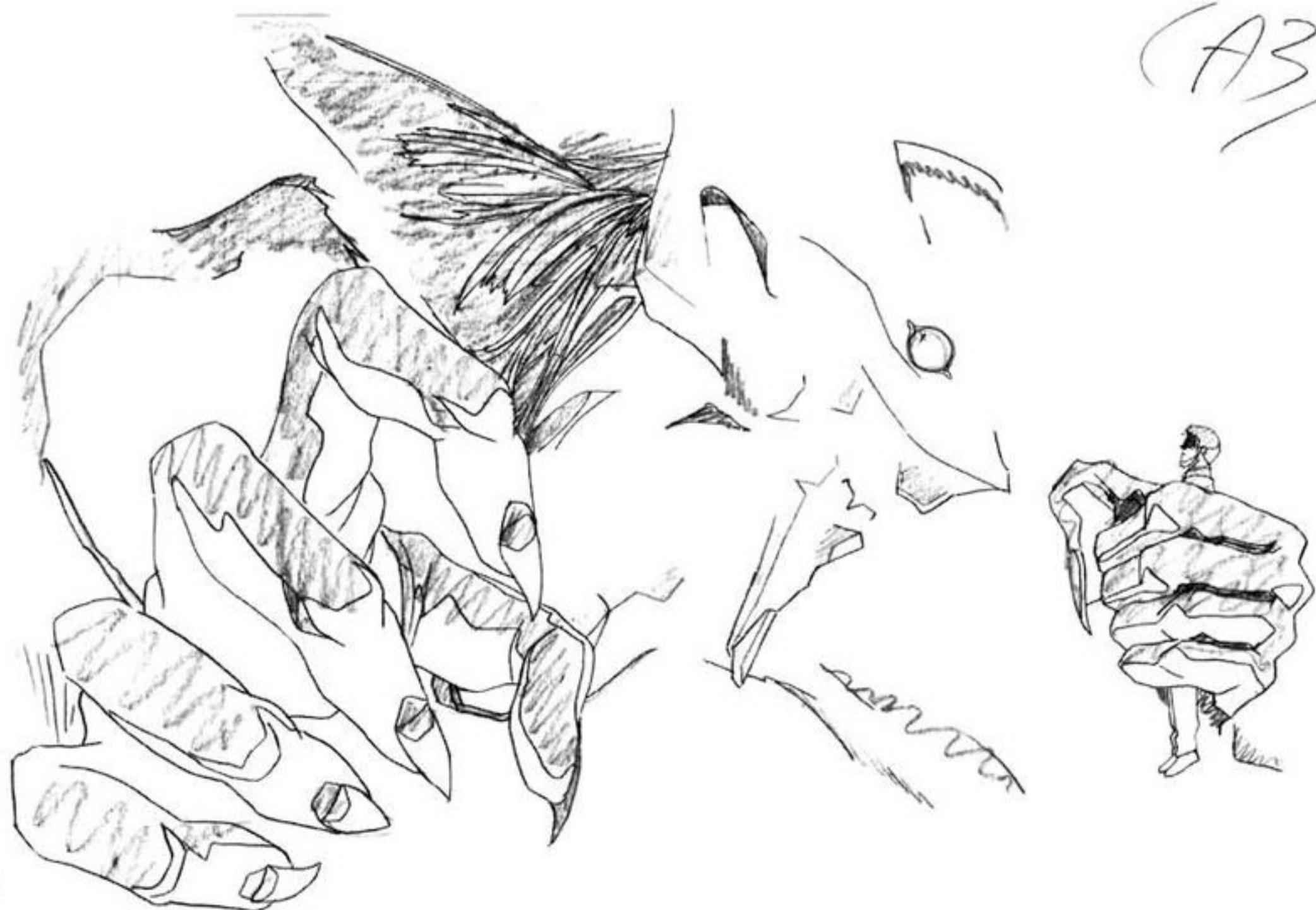

修正原画

#26-C355

AD
23
修

原画
1.2



AD

#26-C357

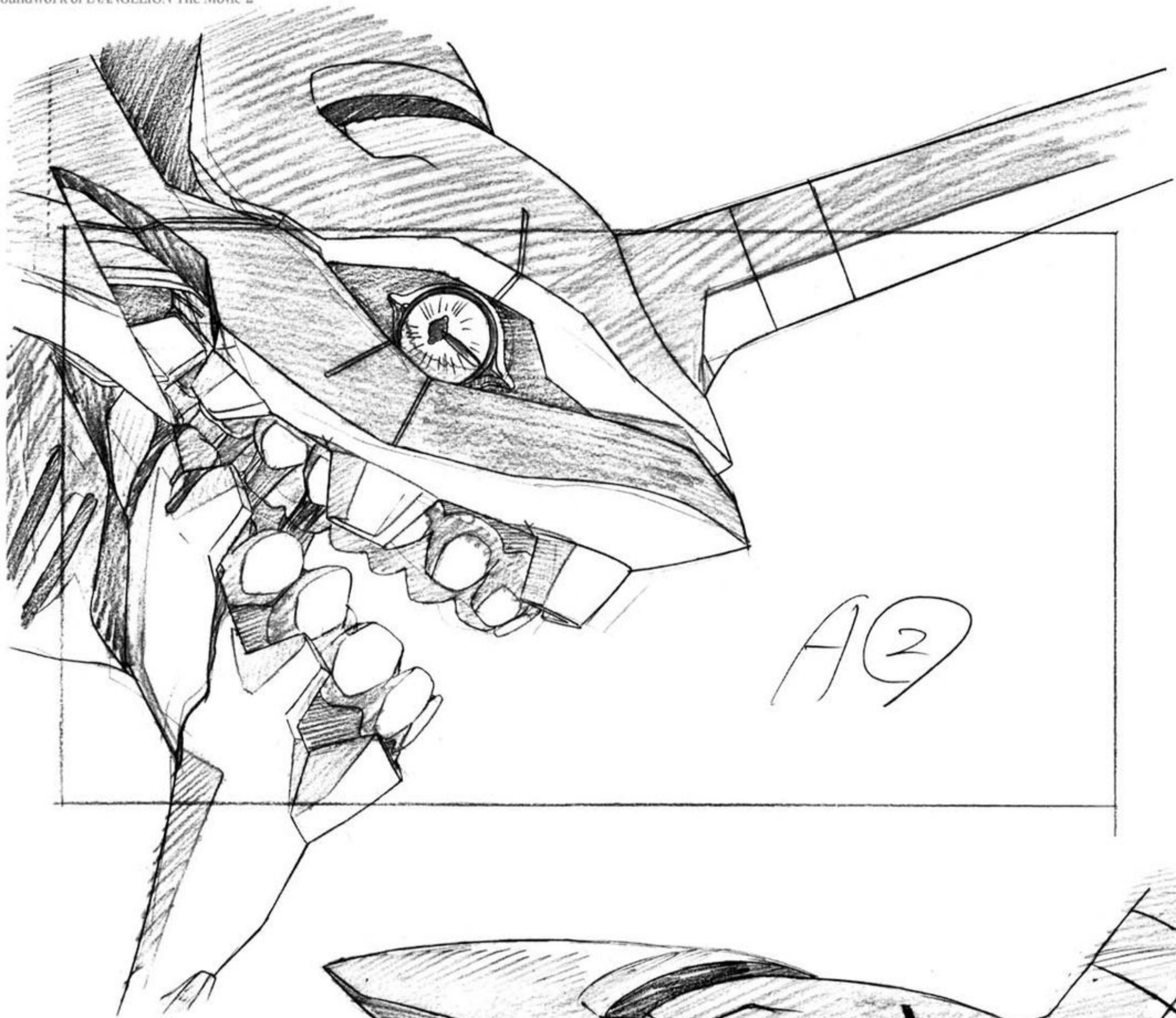

A(2)

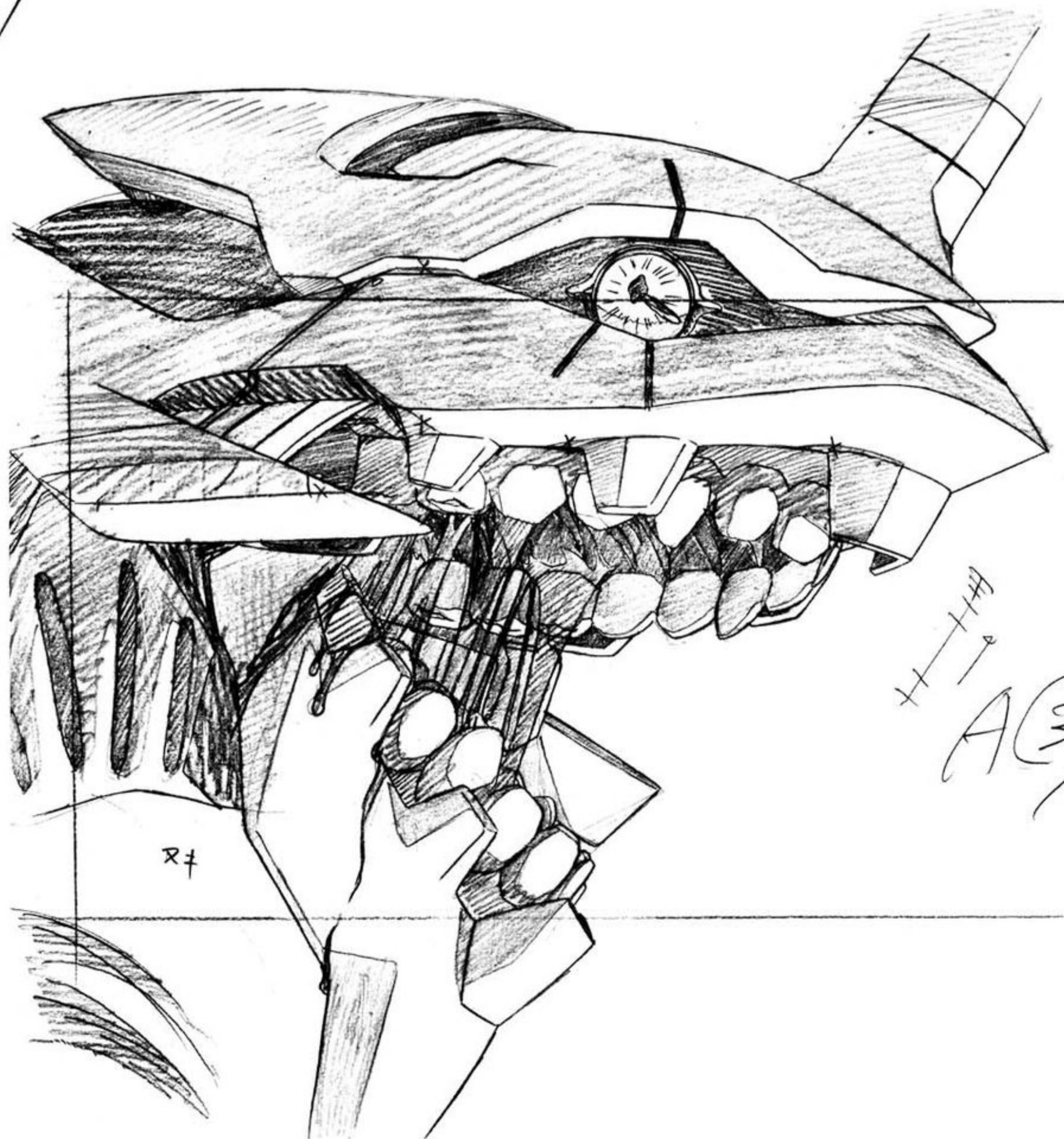

A(3)

x

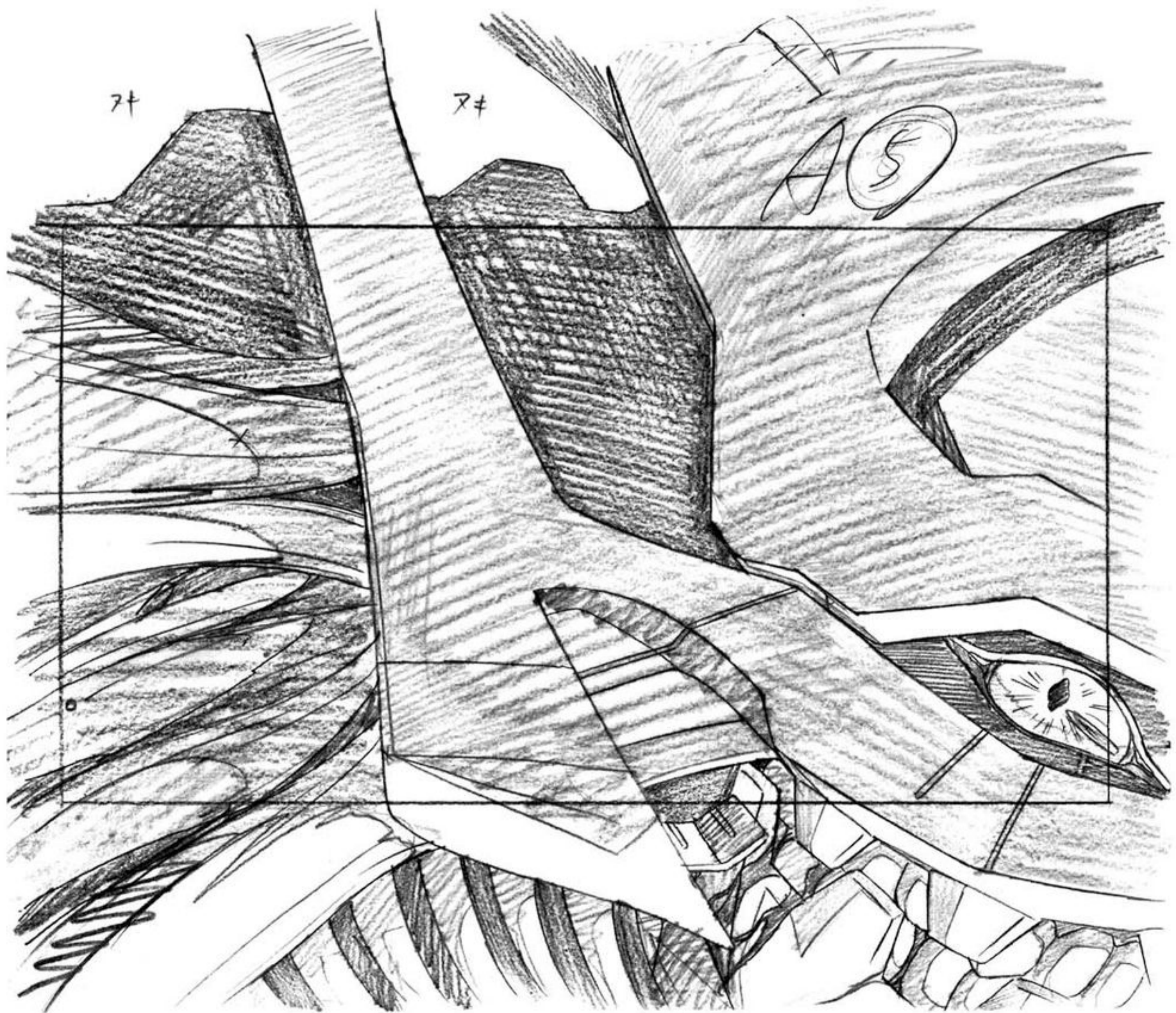
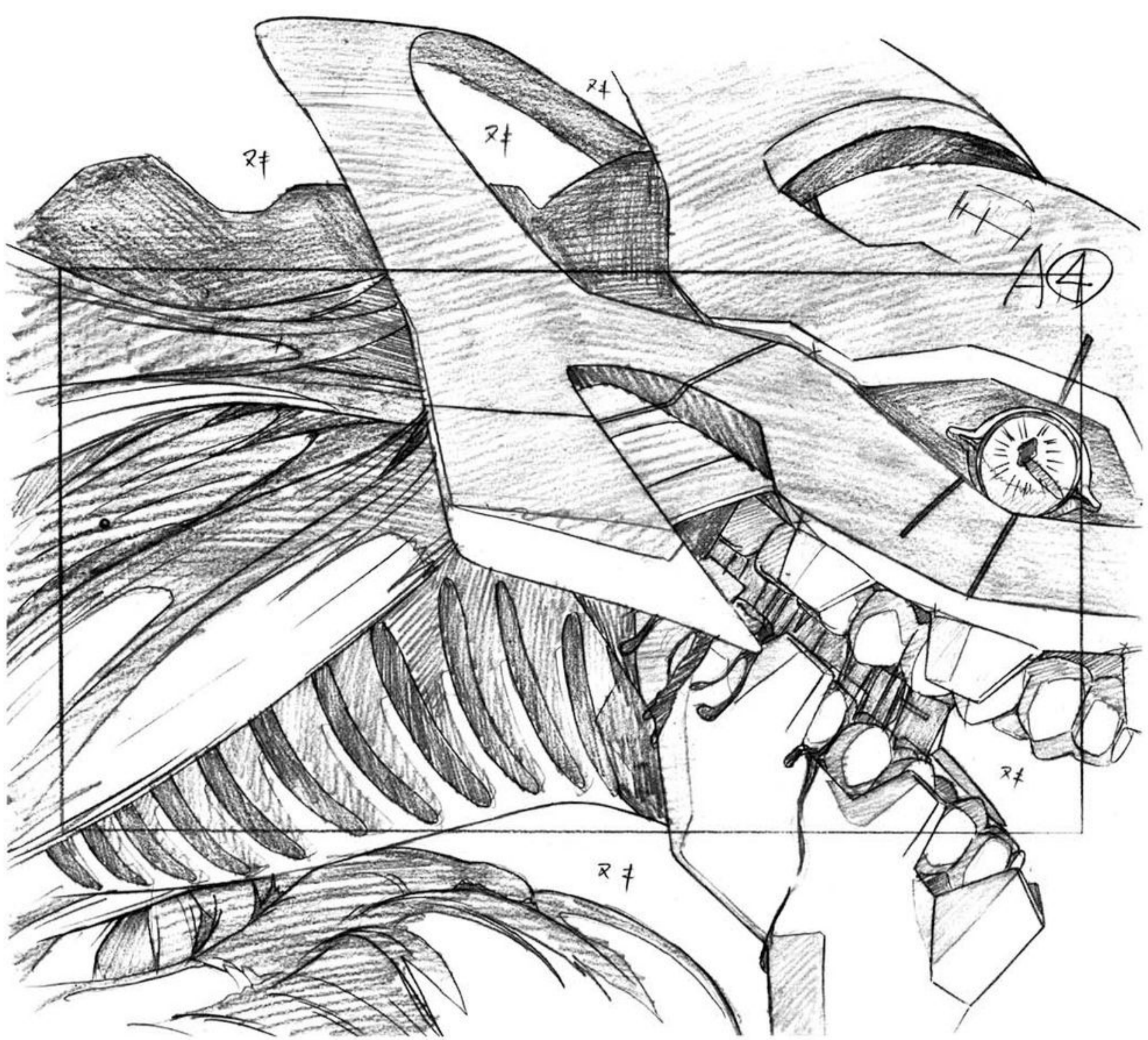



A1
13

AS



A2

3014

A3



A4

#26-C361

3人
白目なし

A
後



C①) 瞳の
2) ハイト
ブル

Aの
後

#26-C379

17分
0:10 後

「アツク」



#26-C364
レイアウト時作監修正

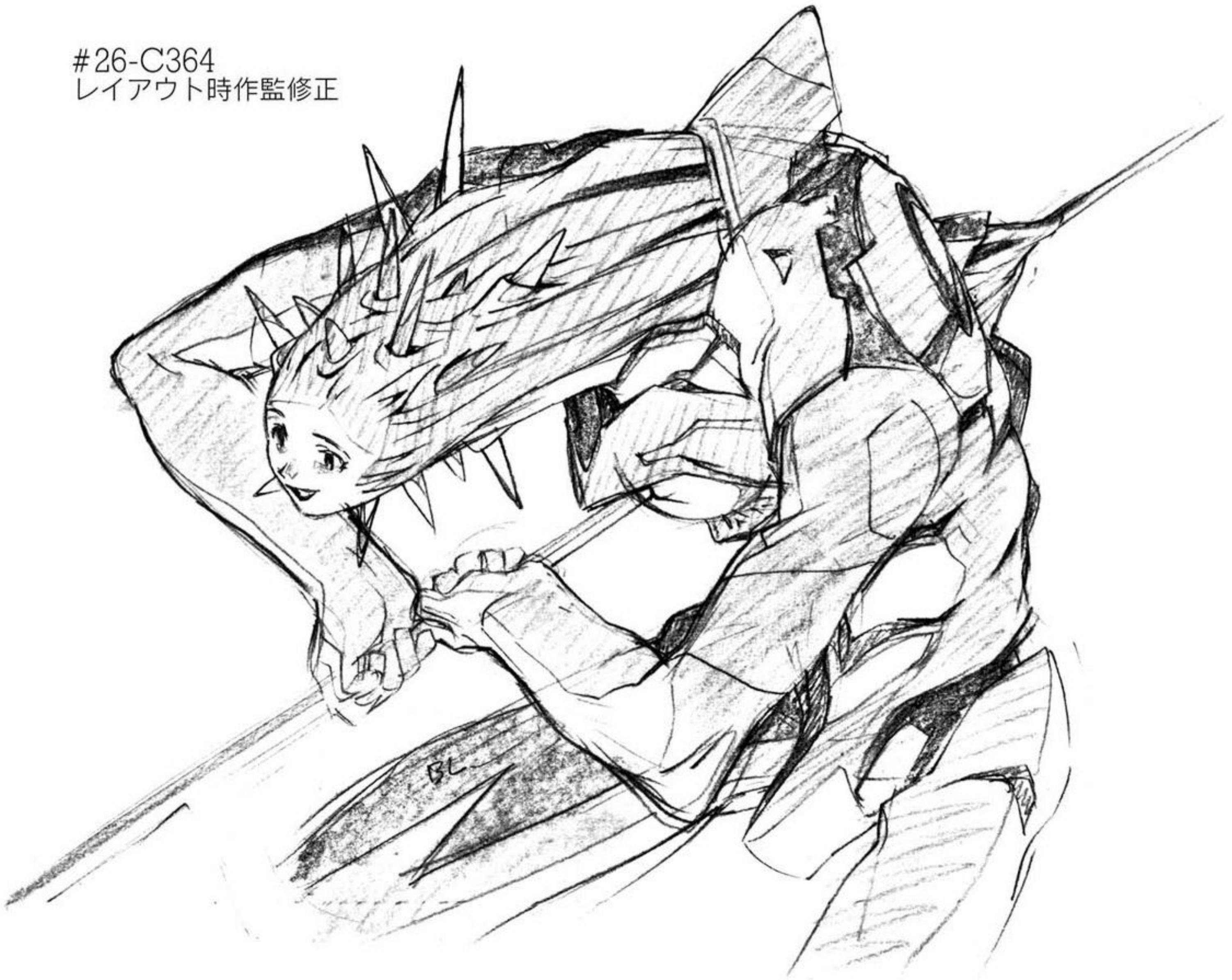

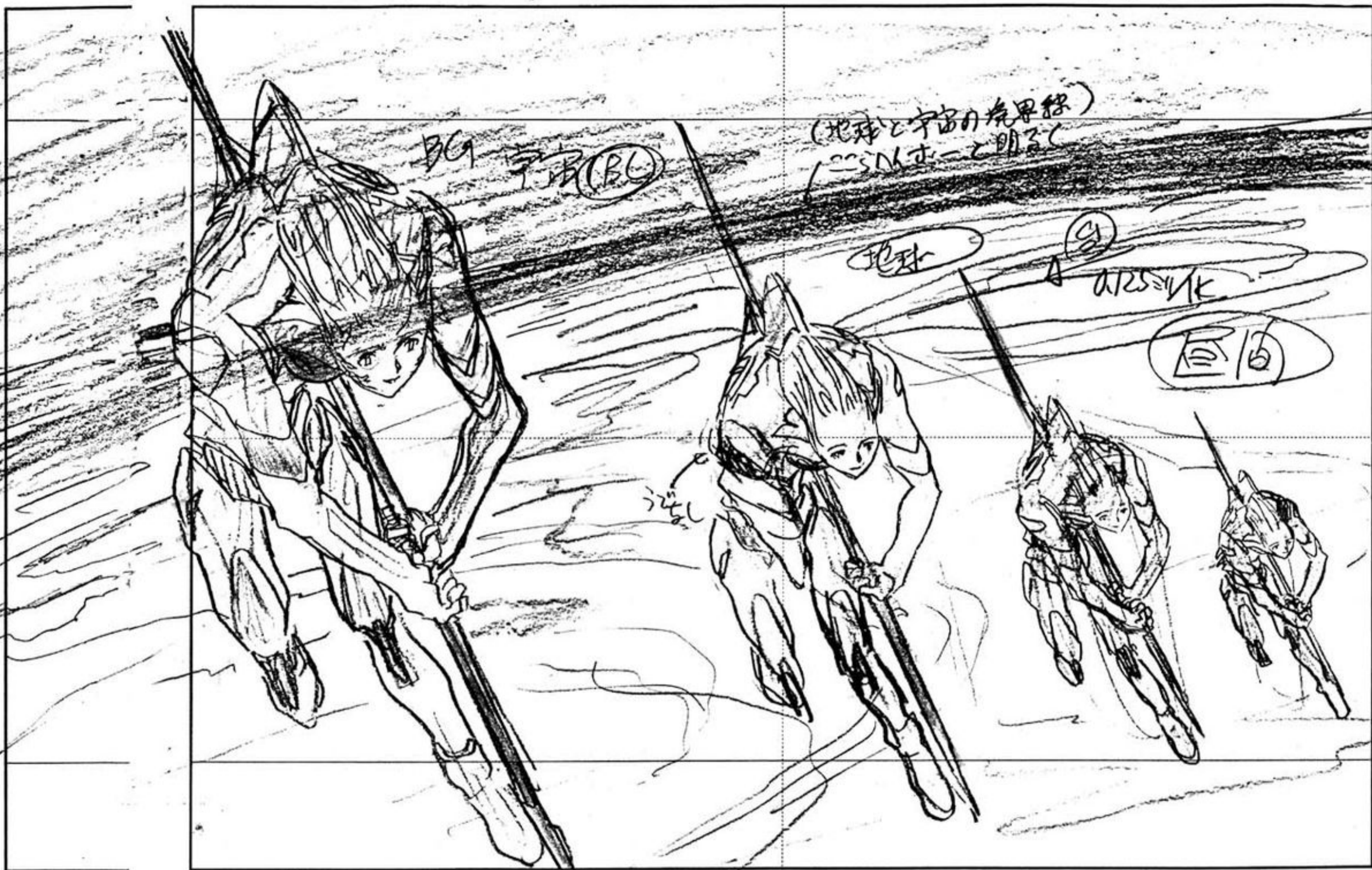

A → B
PAN

#26-C366Aレイアウト

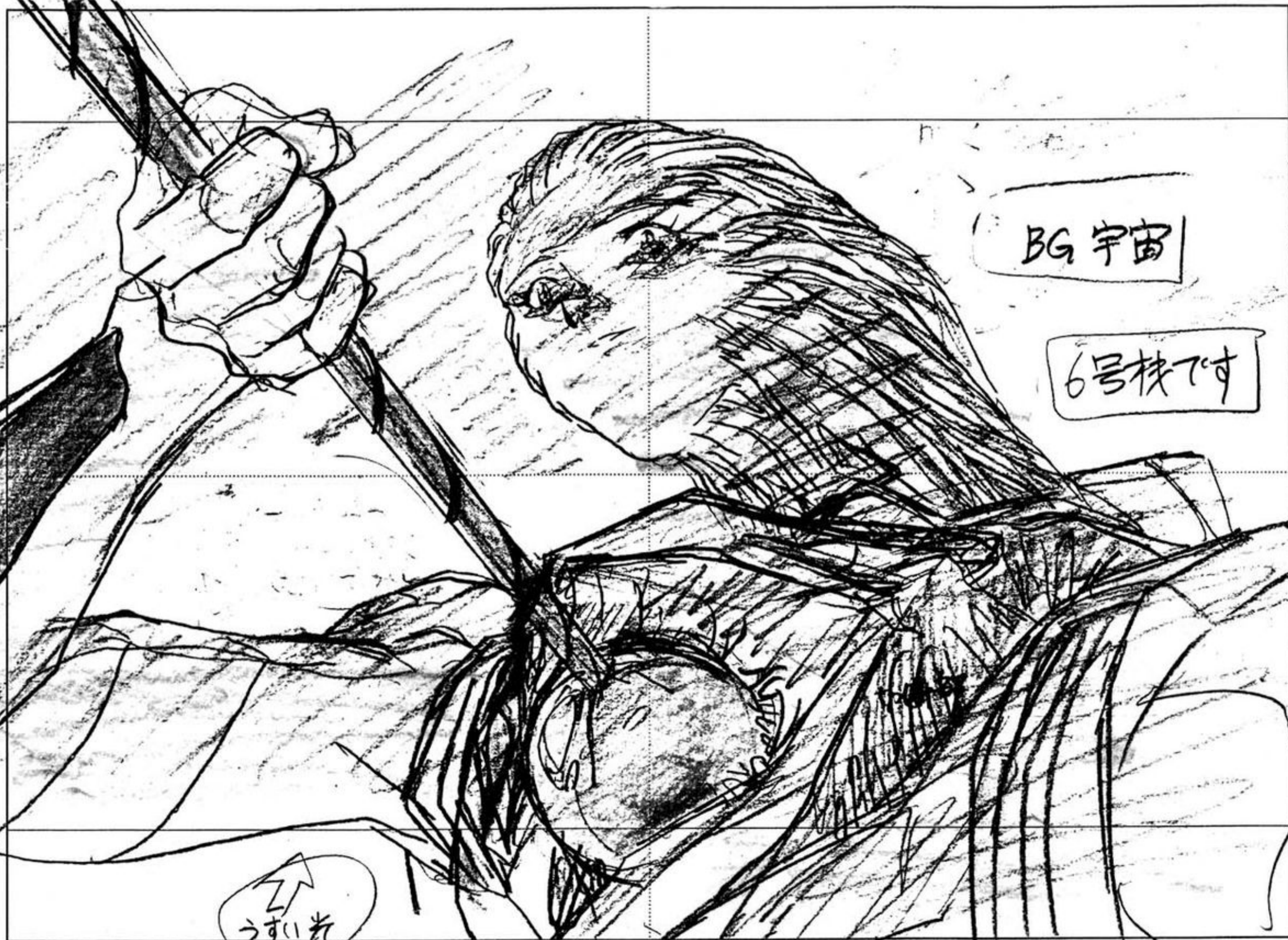

↑
うすい光

#26-C373レイアウト

→スタート

0.125mm/2K

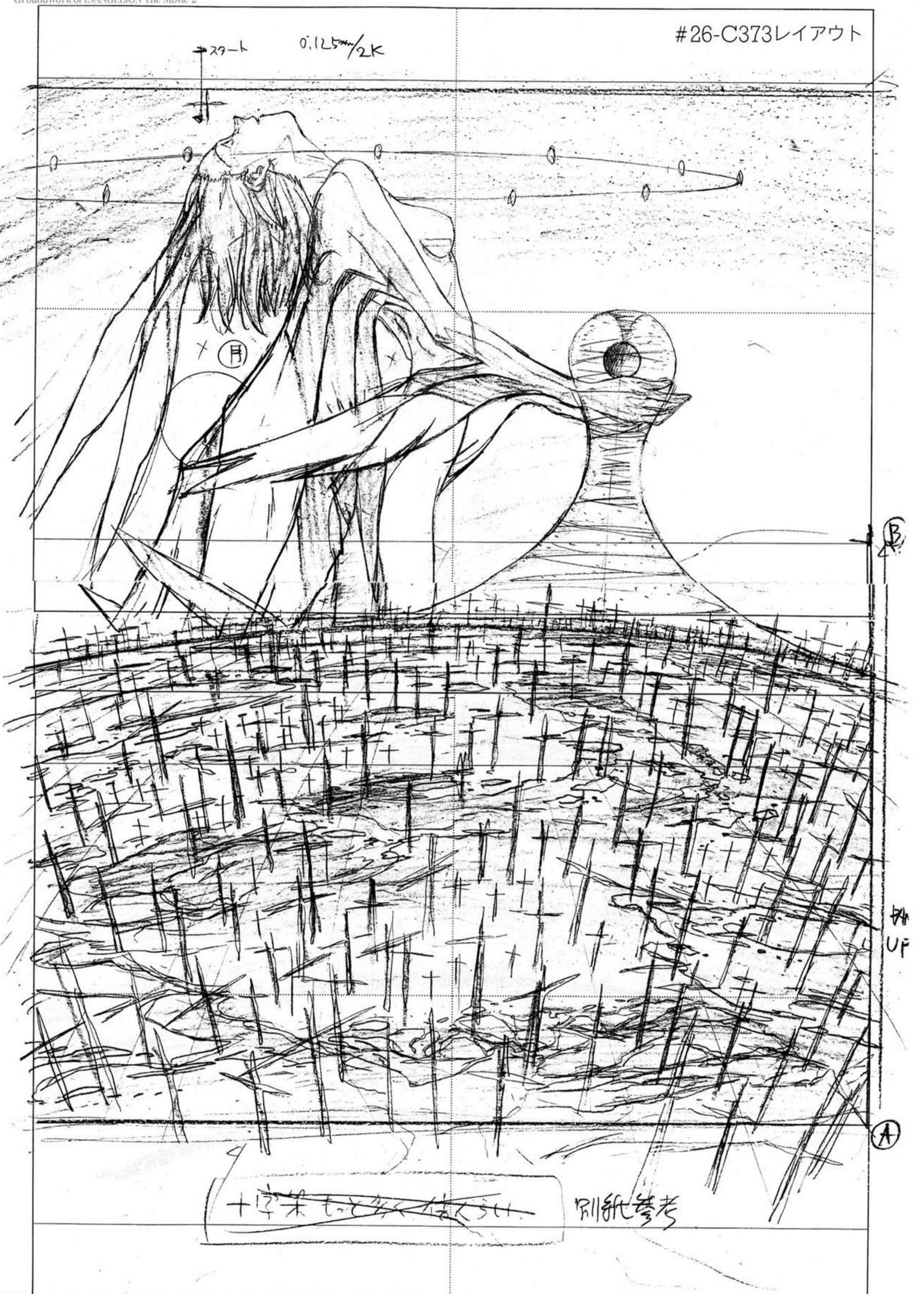

~~十字架の塔を動かす~~

別紙参考

B

UP

A

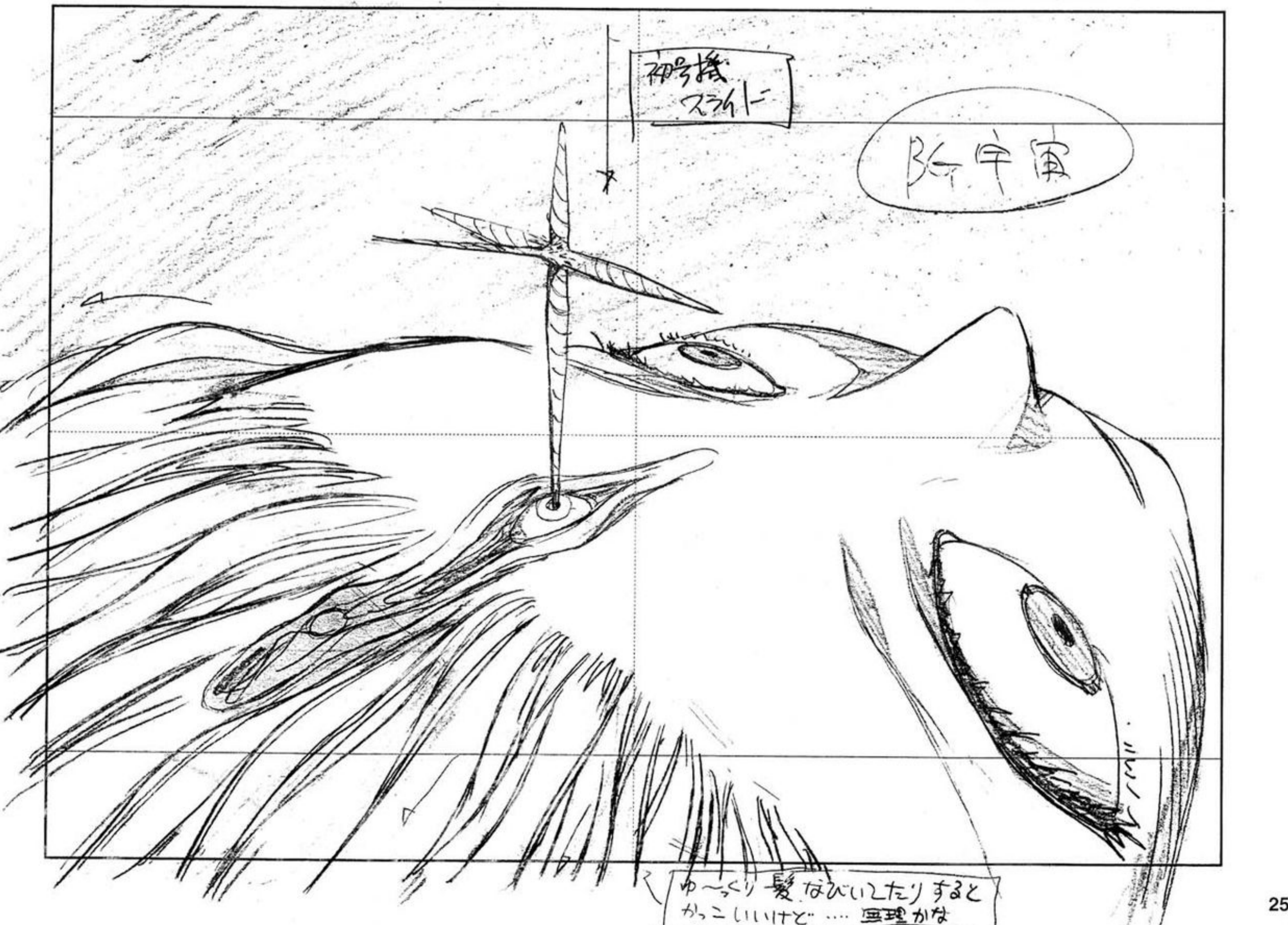

C2



C3



④ END

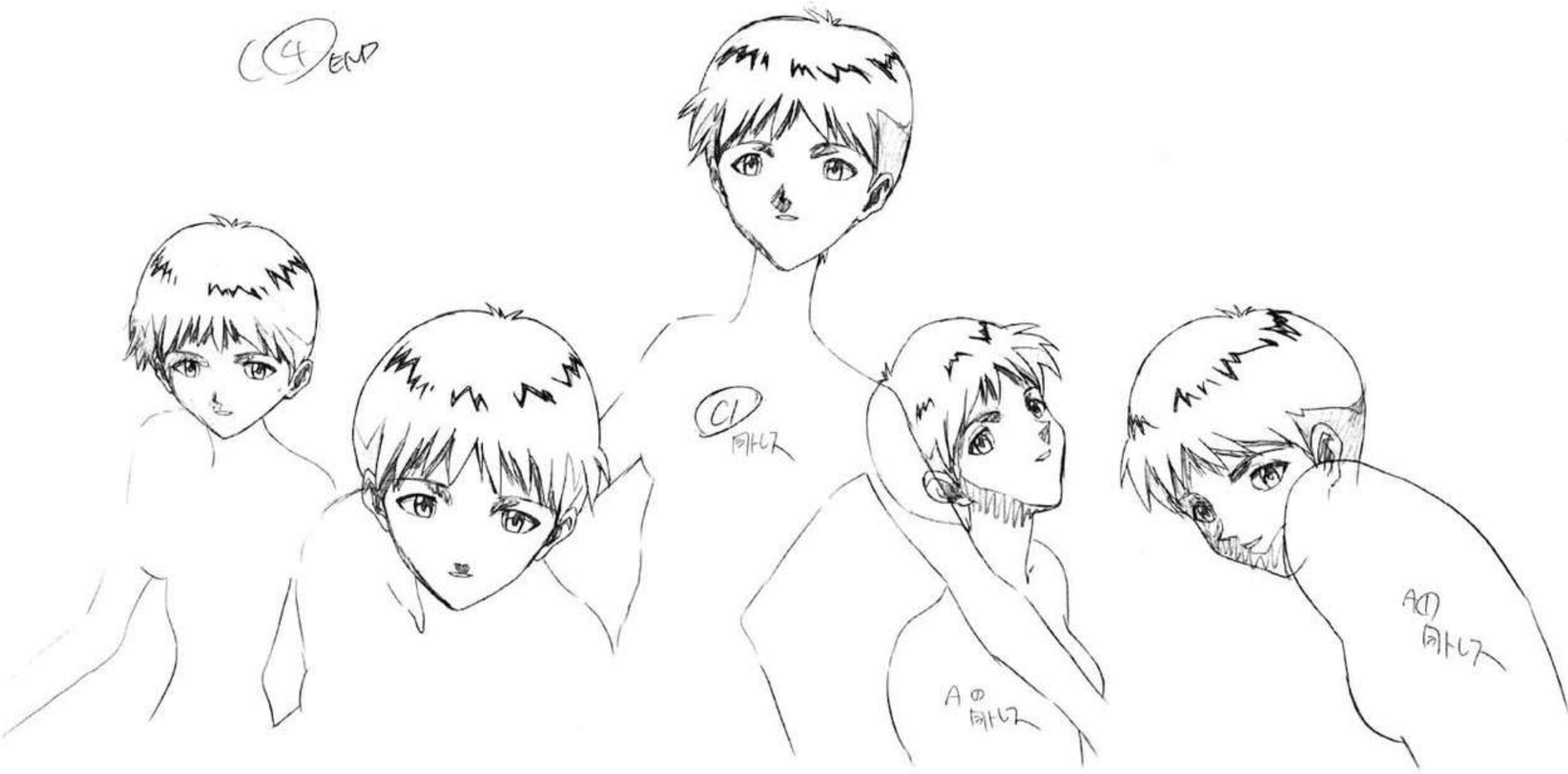

修正原画

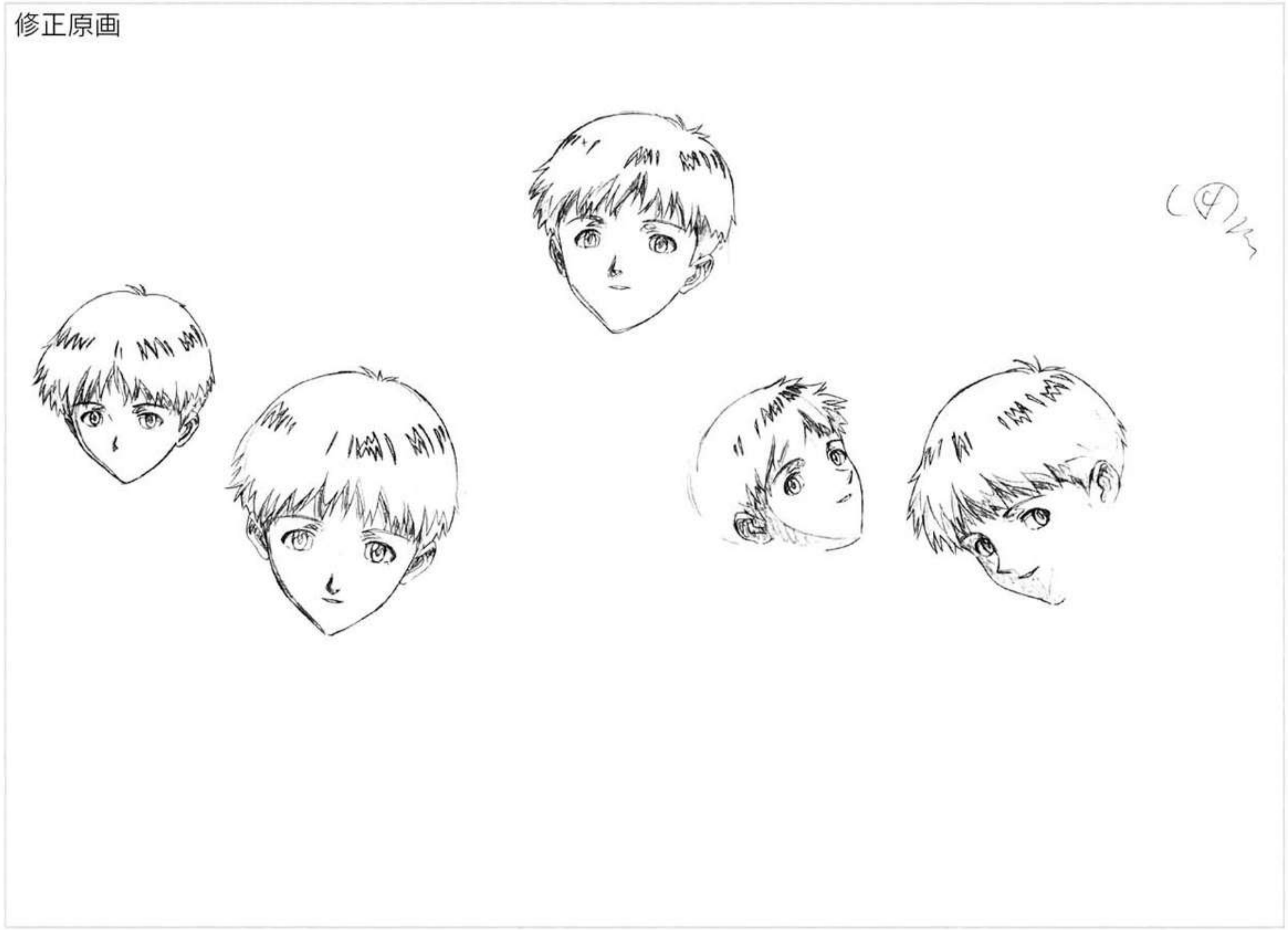

L



#26-C382

修正原画





修正原画



B(2)



修正原画



① B2 1/3

中物 参考 ①

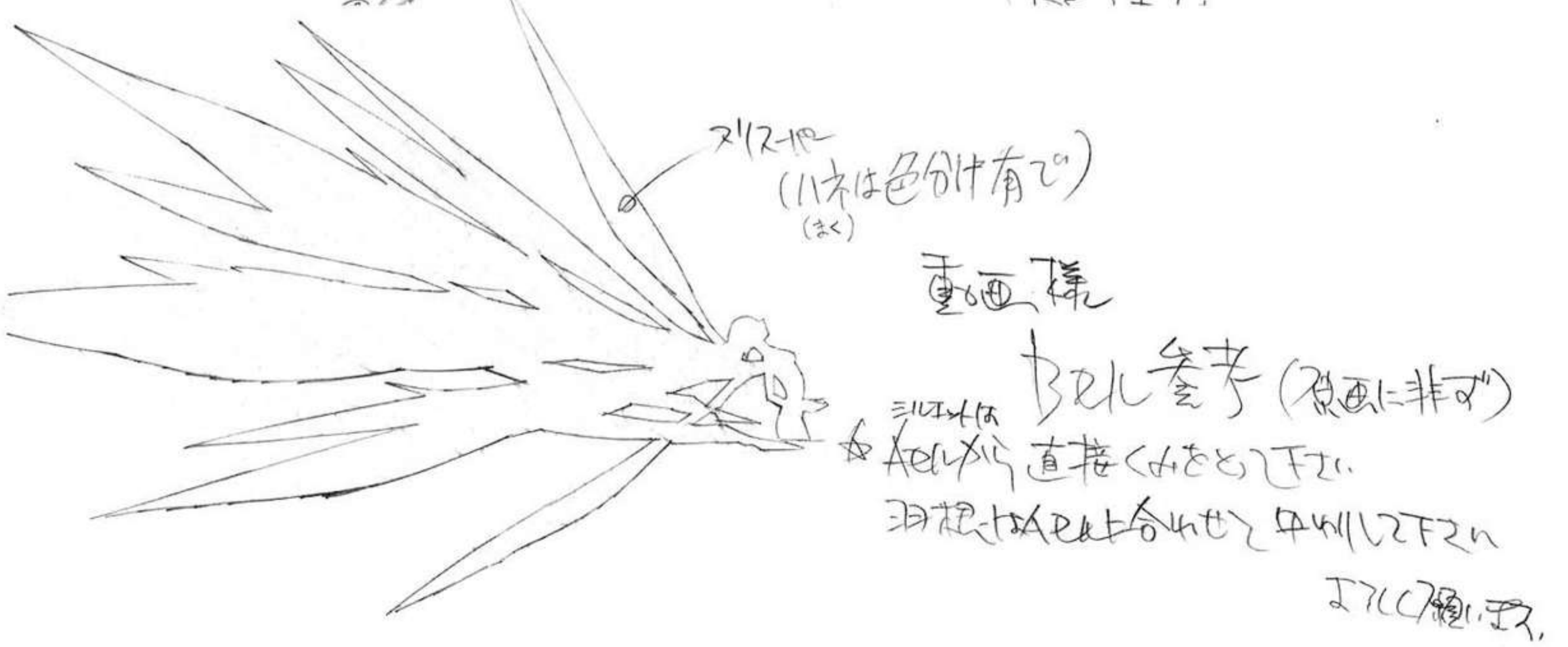
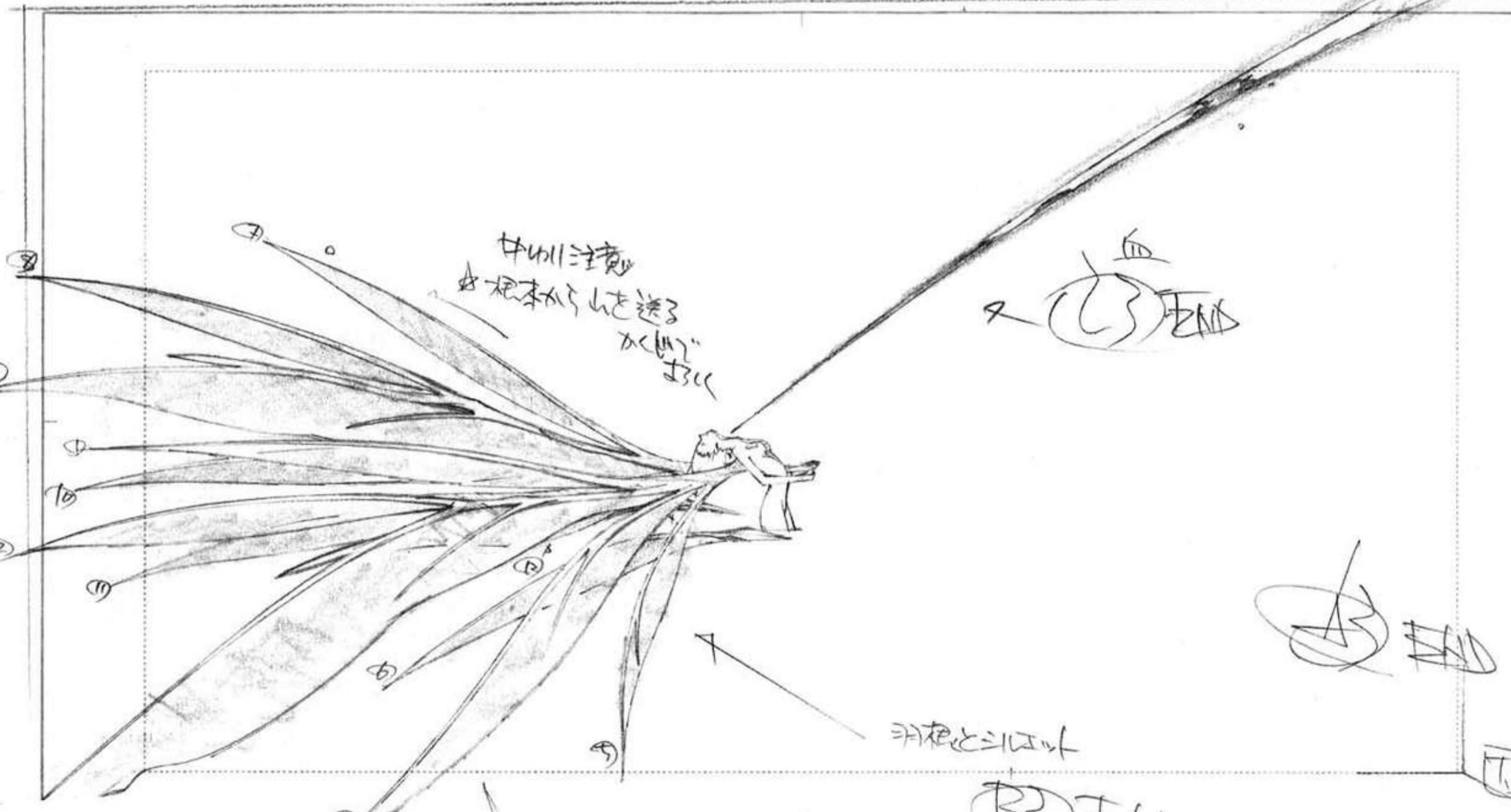
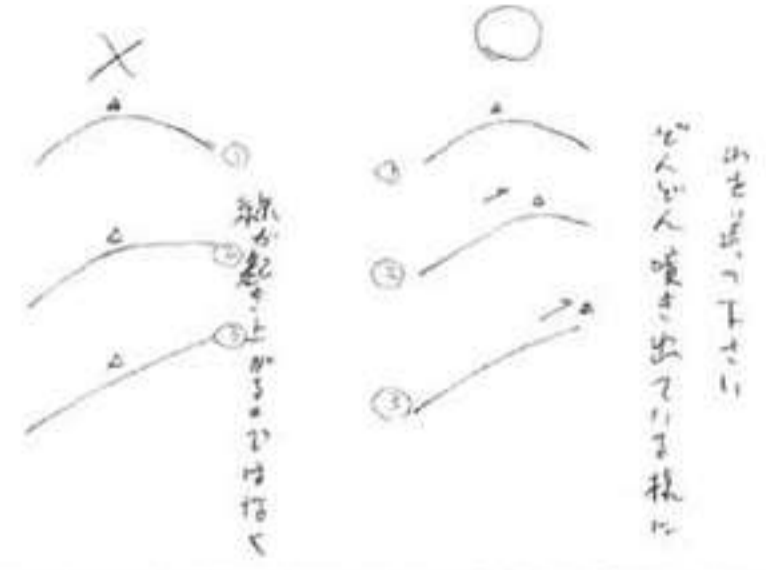

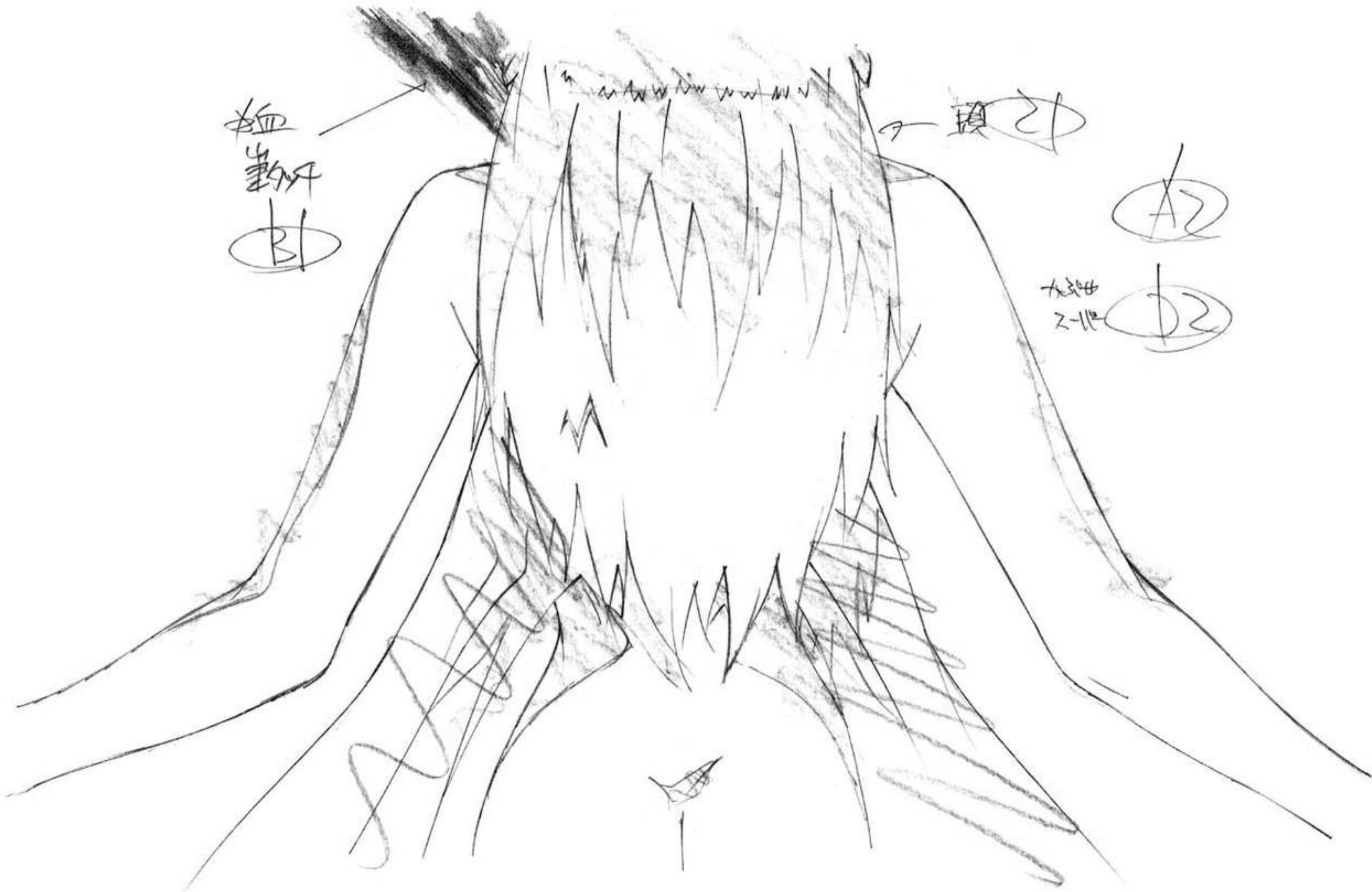



修正原画





修正原画





#26-C390

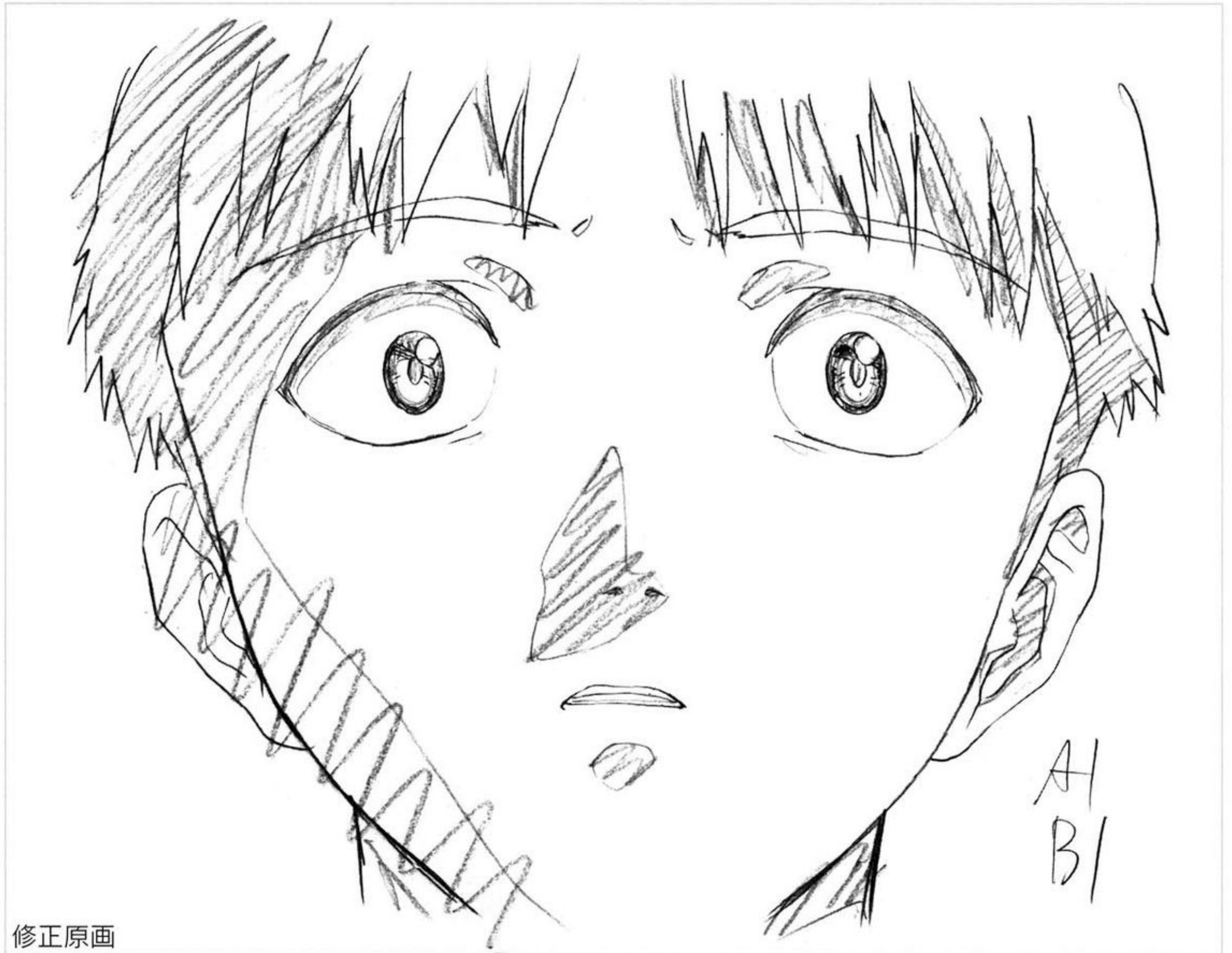

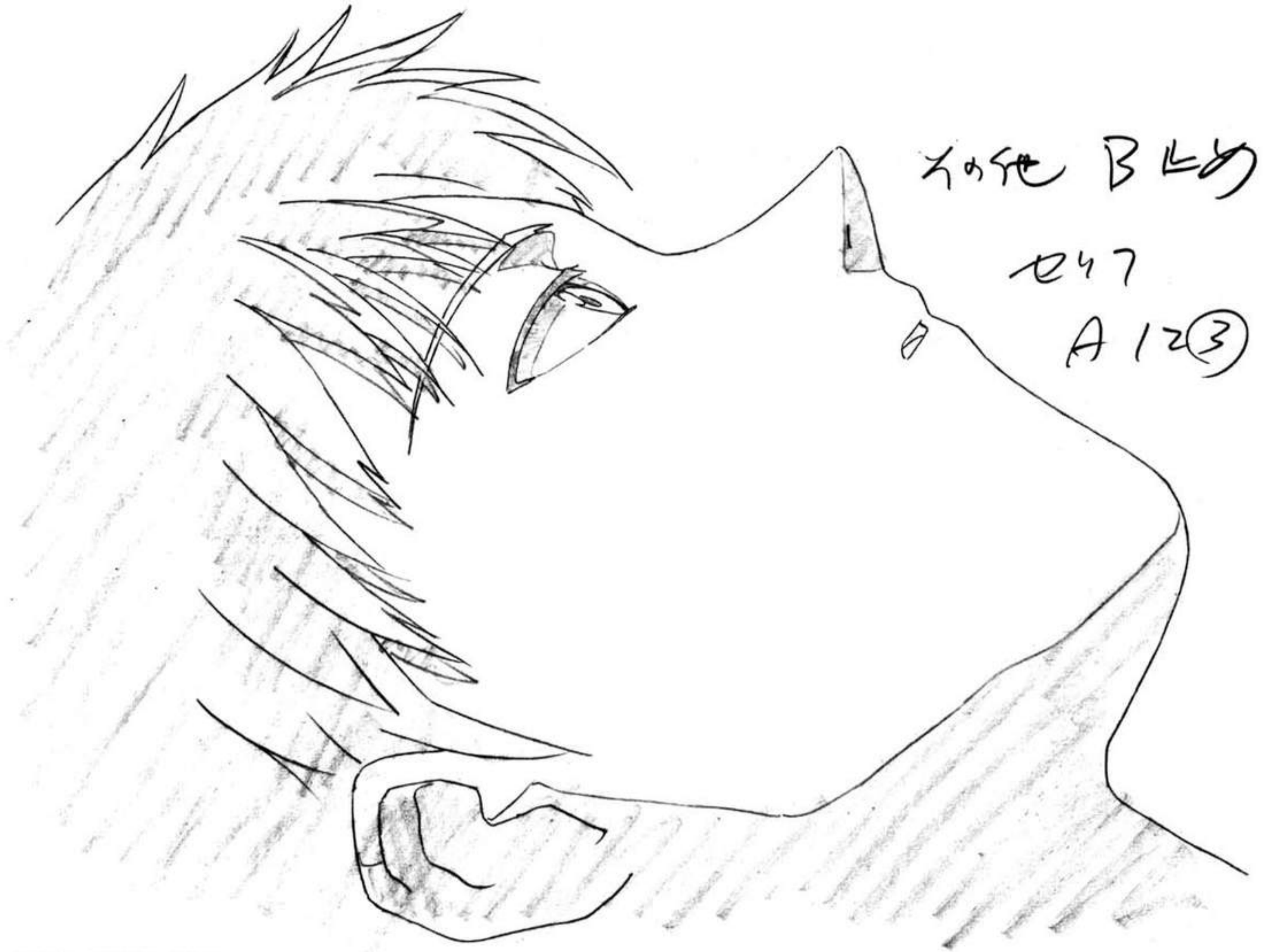

#26-C392,398



修正原画

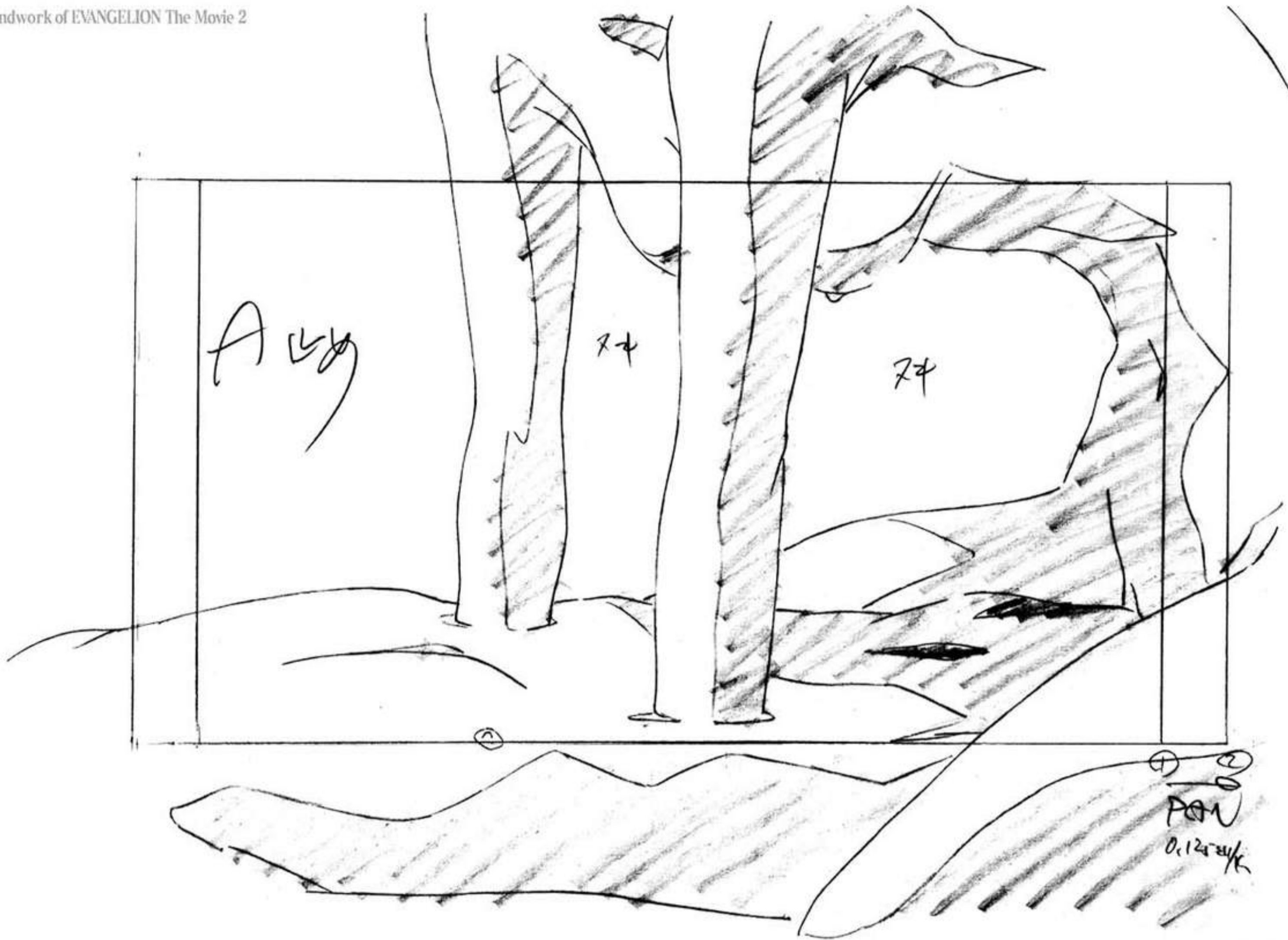

#26-C395

修正原画



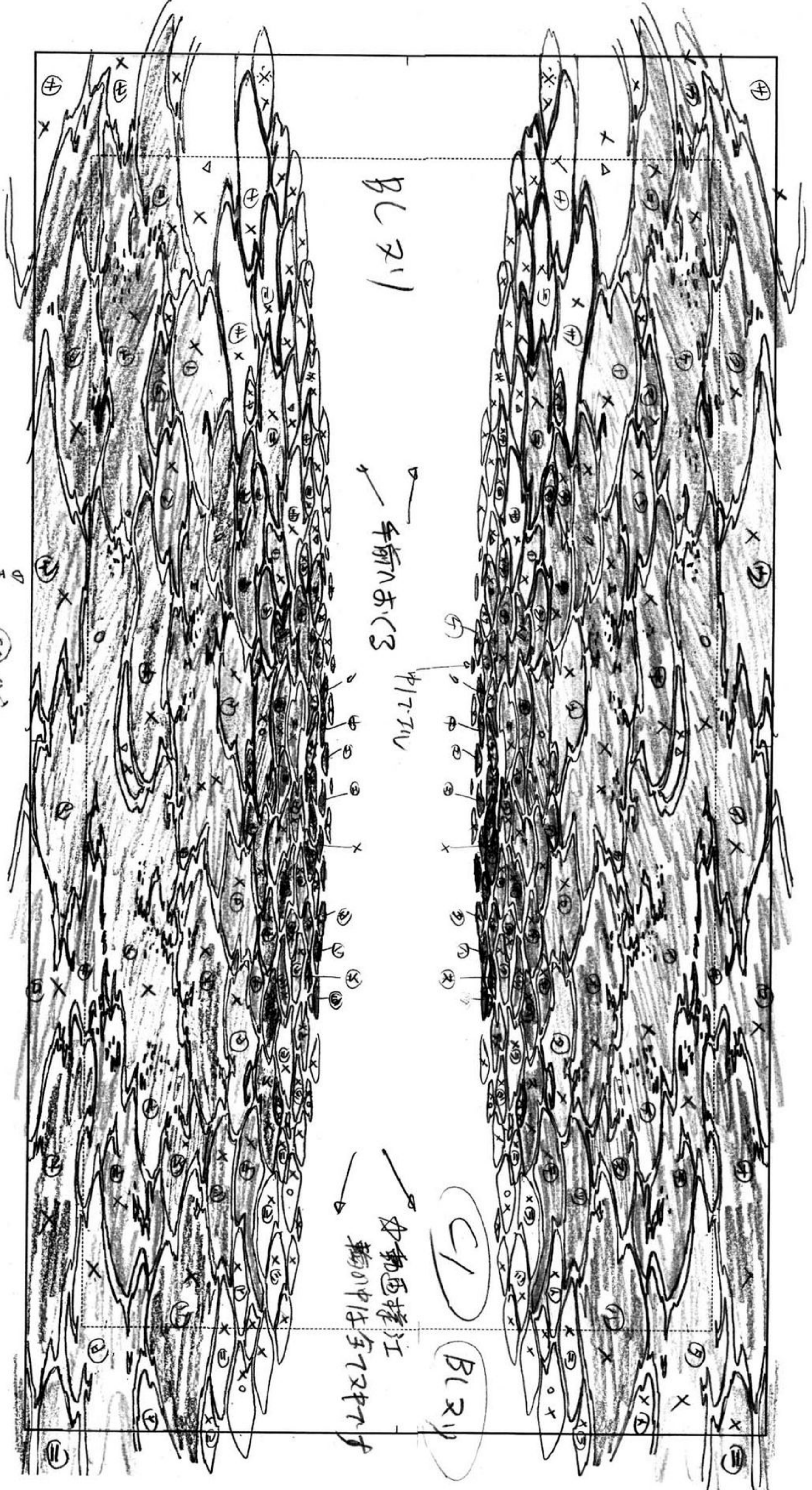

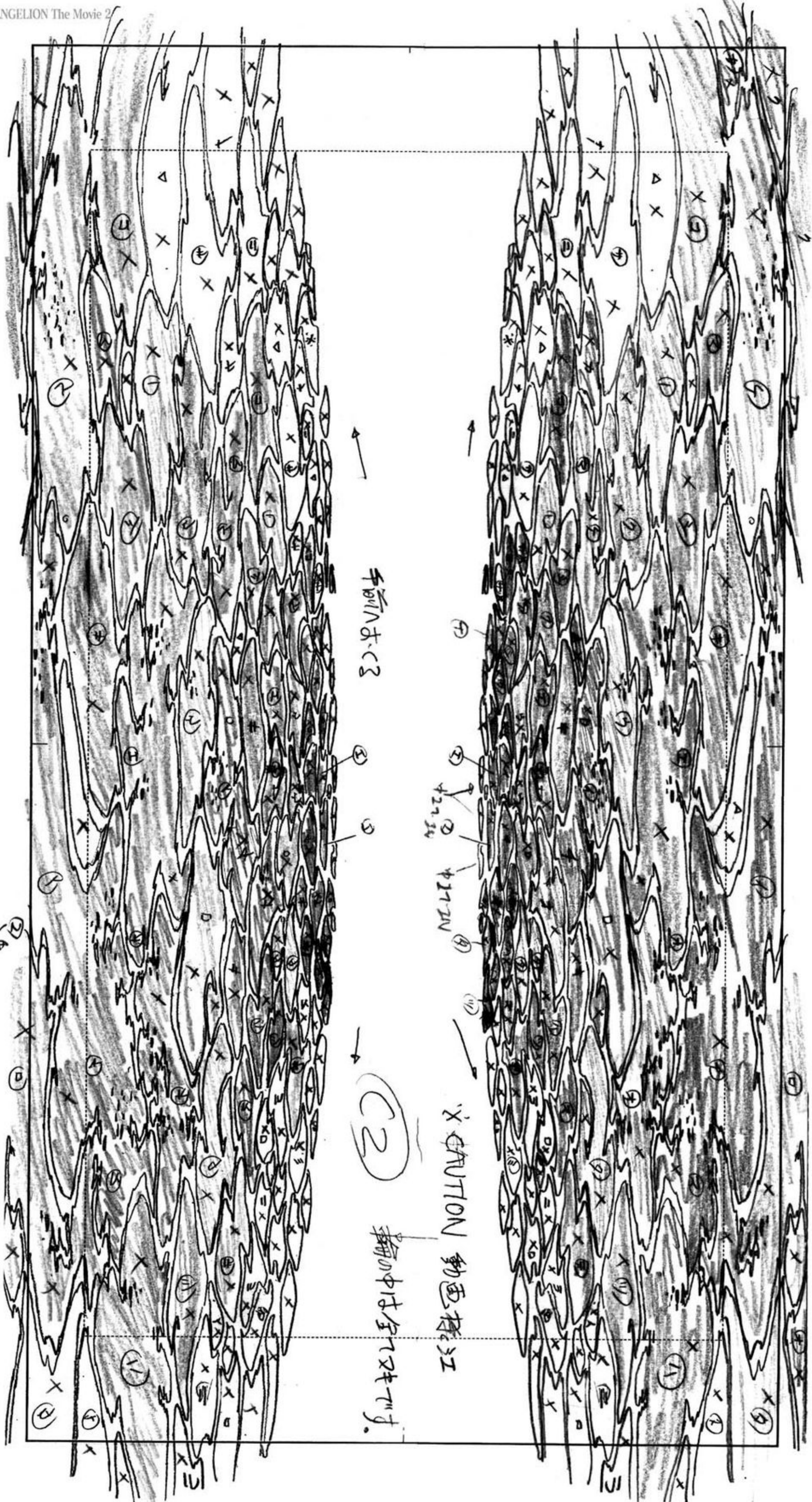

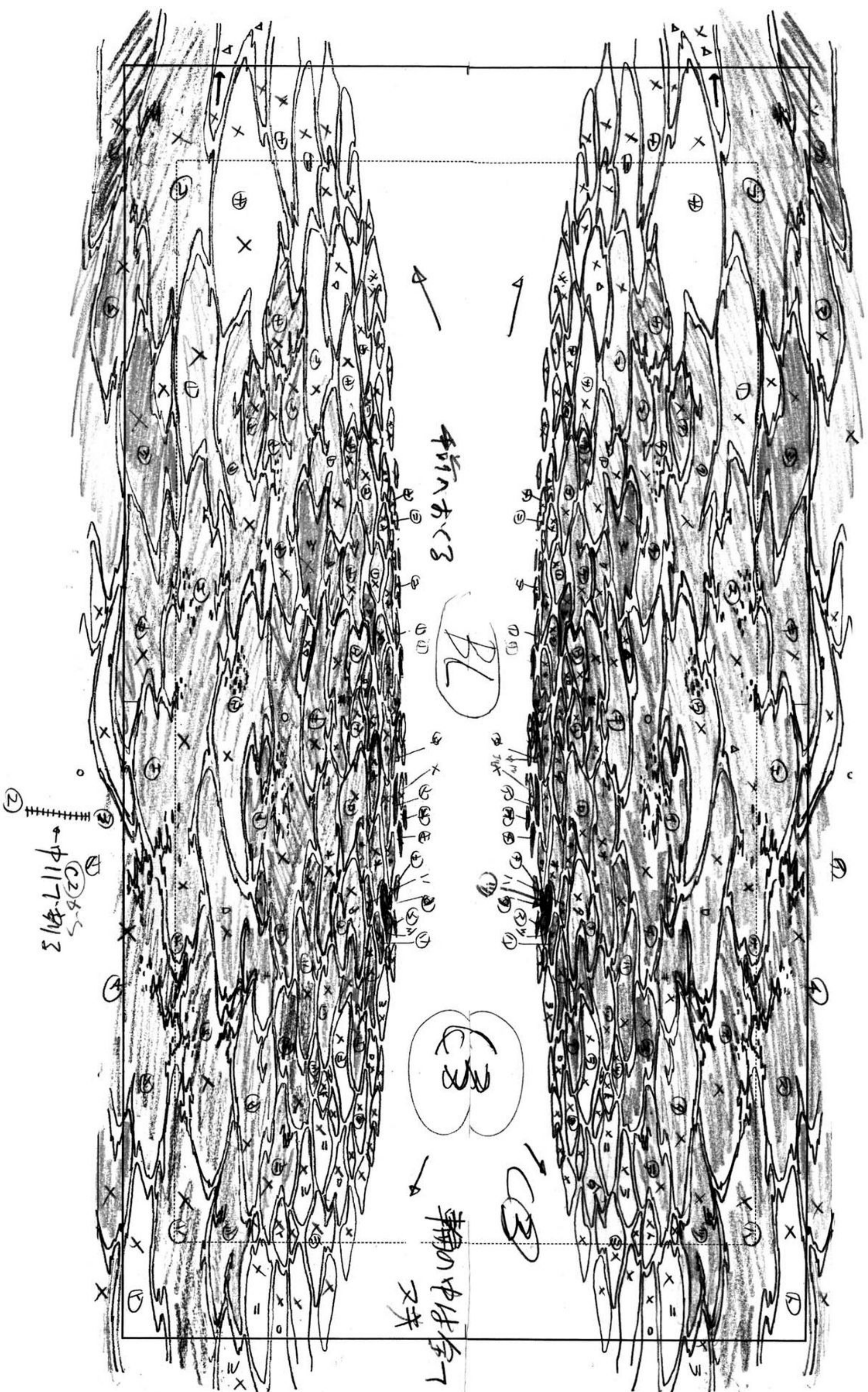

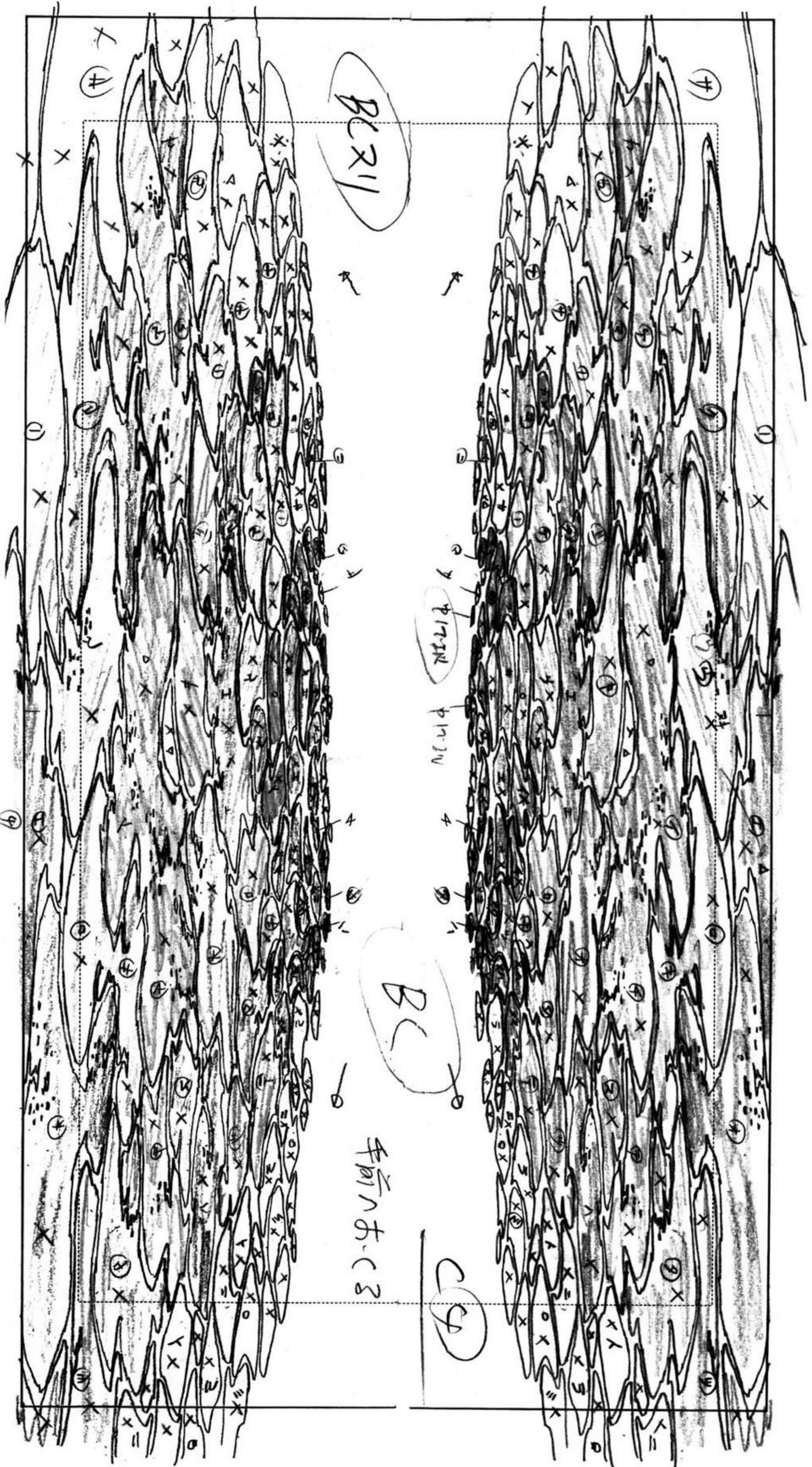

#26-C406

#26-C408

B1



B2



2-3



#26-C409



#26-C410,414

てん BO (3)

A1

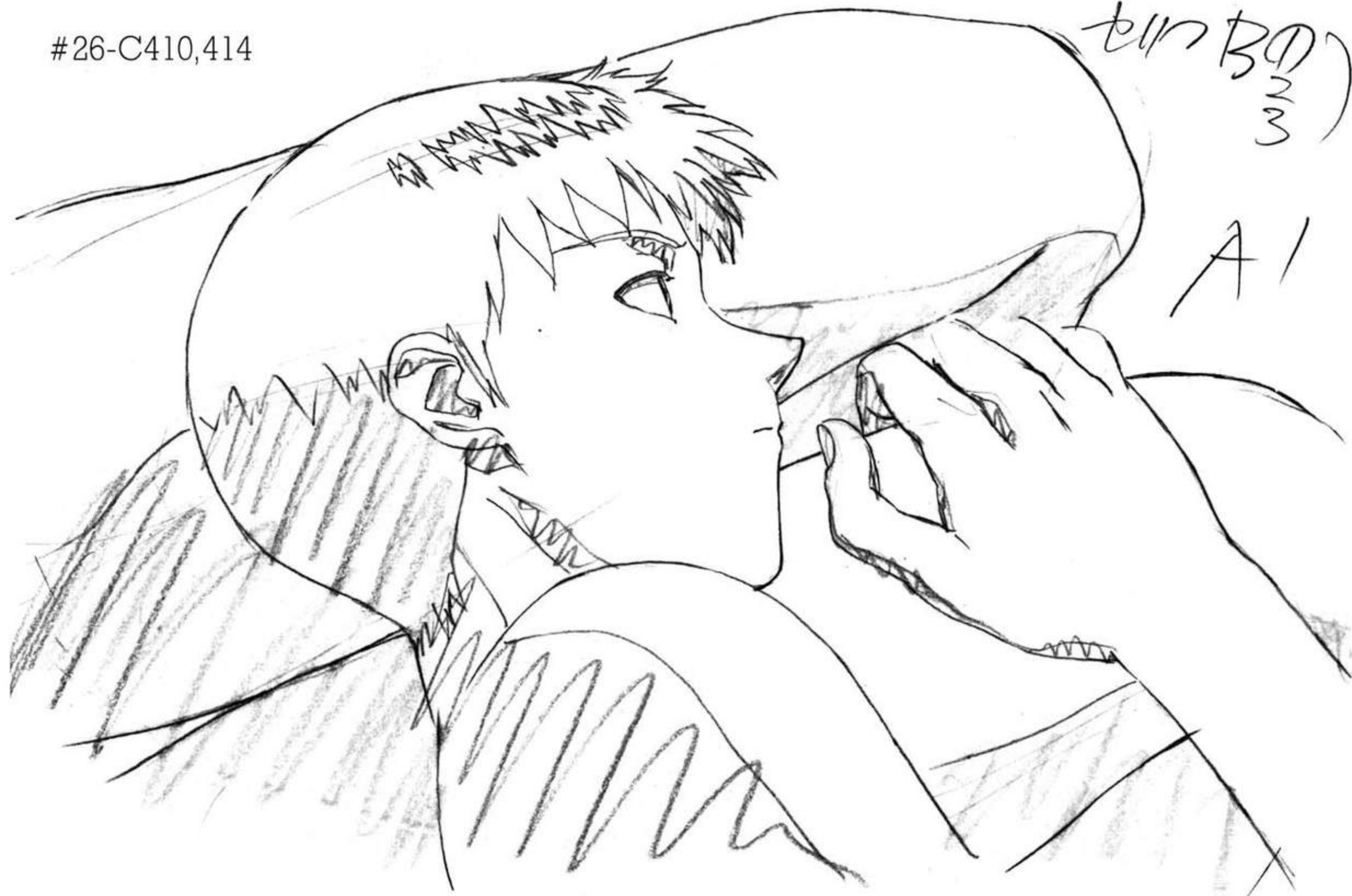

A1

#26-C412

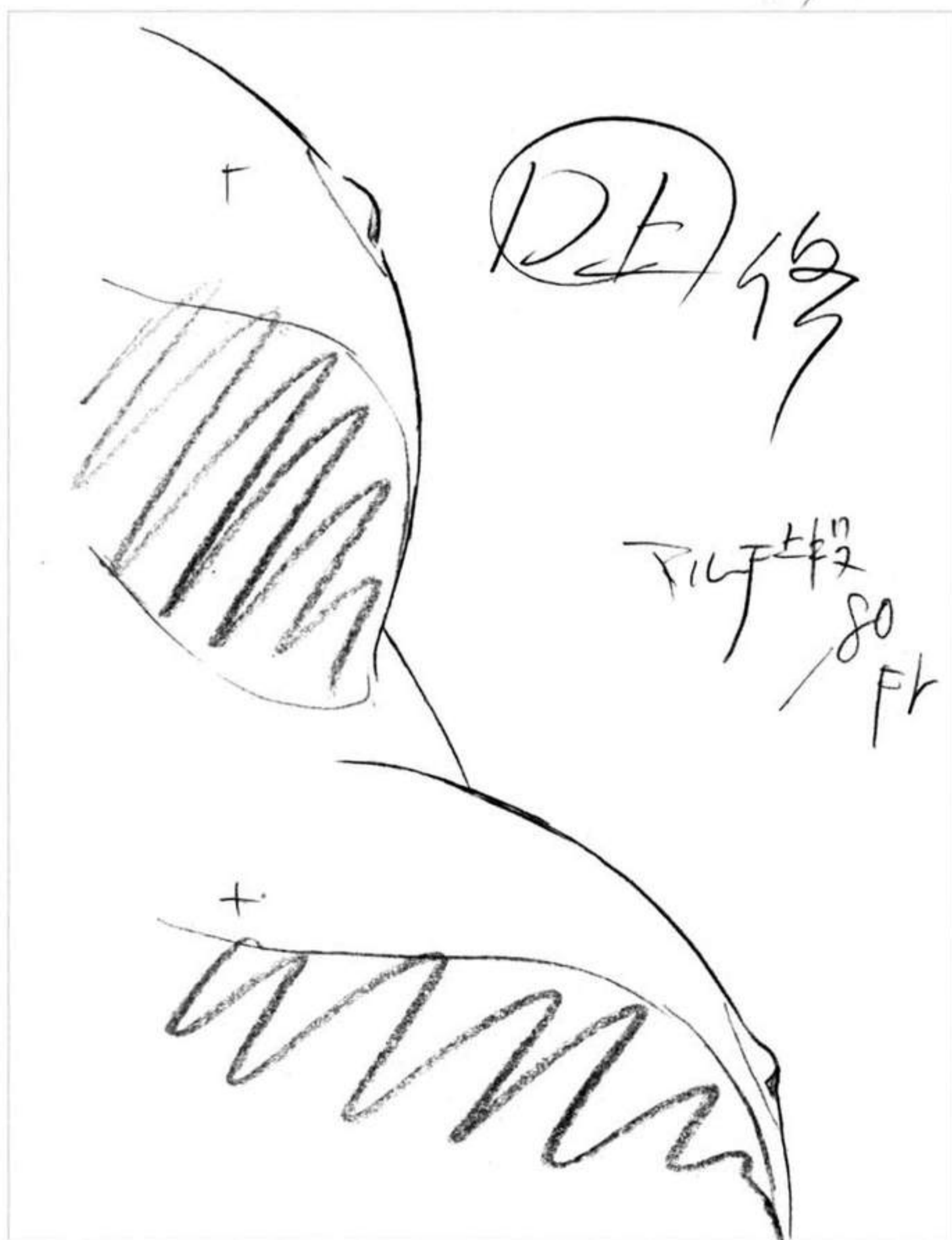

DE 1/2

16F 1/2
80
Fr



#26-C412

修正原画

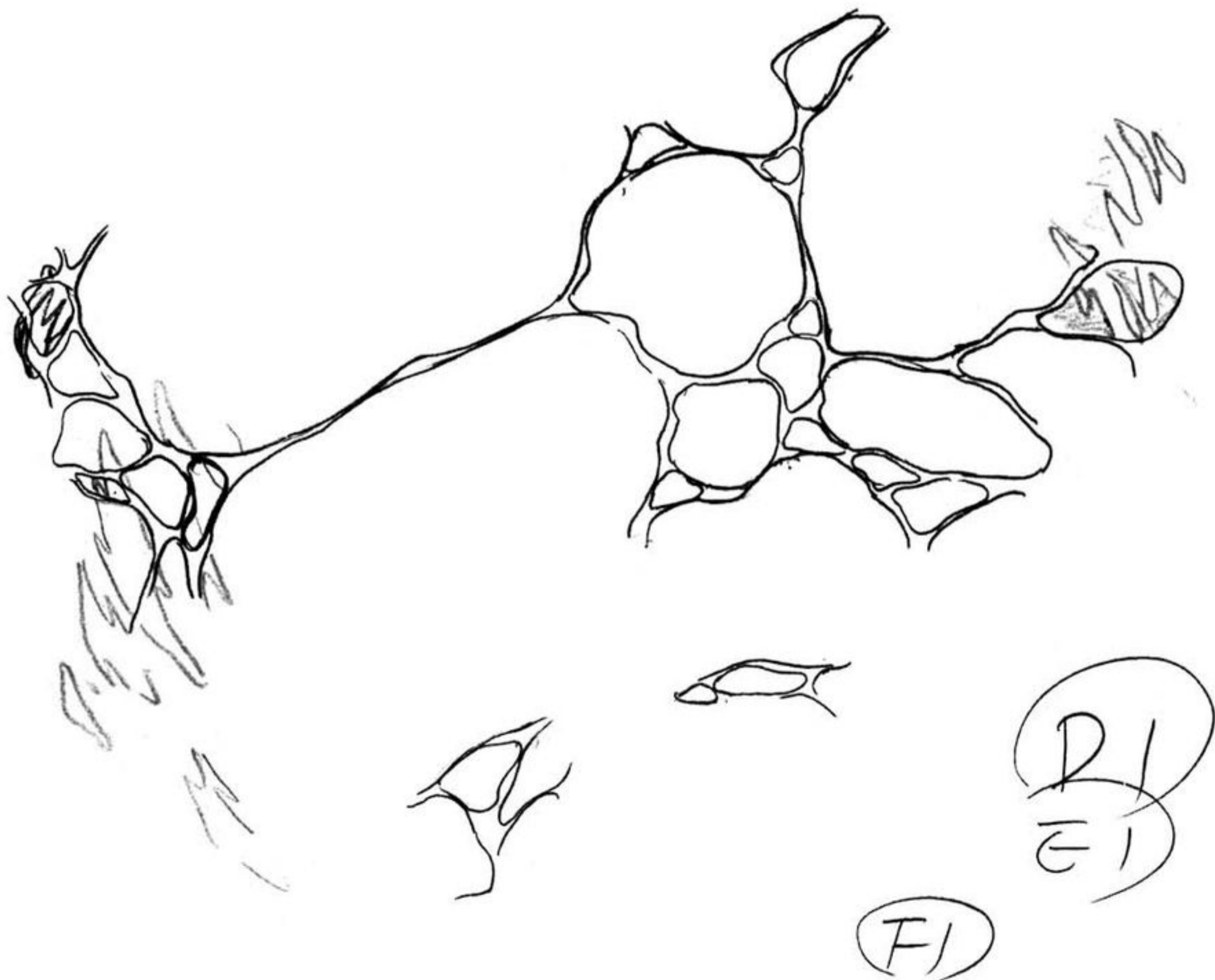



修正原画



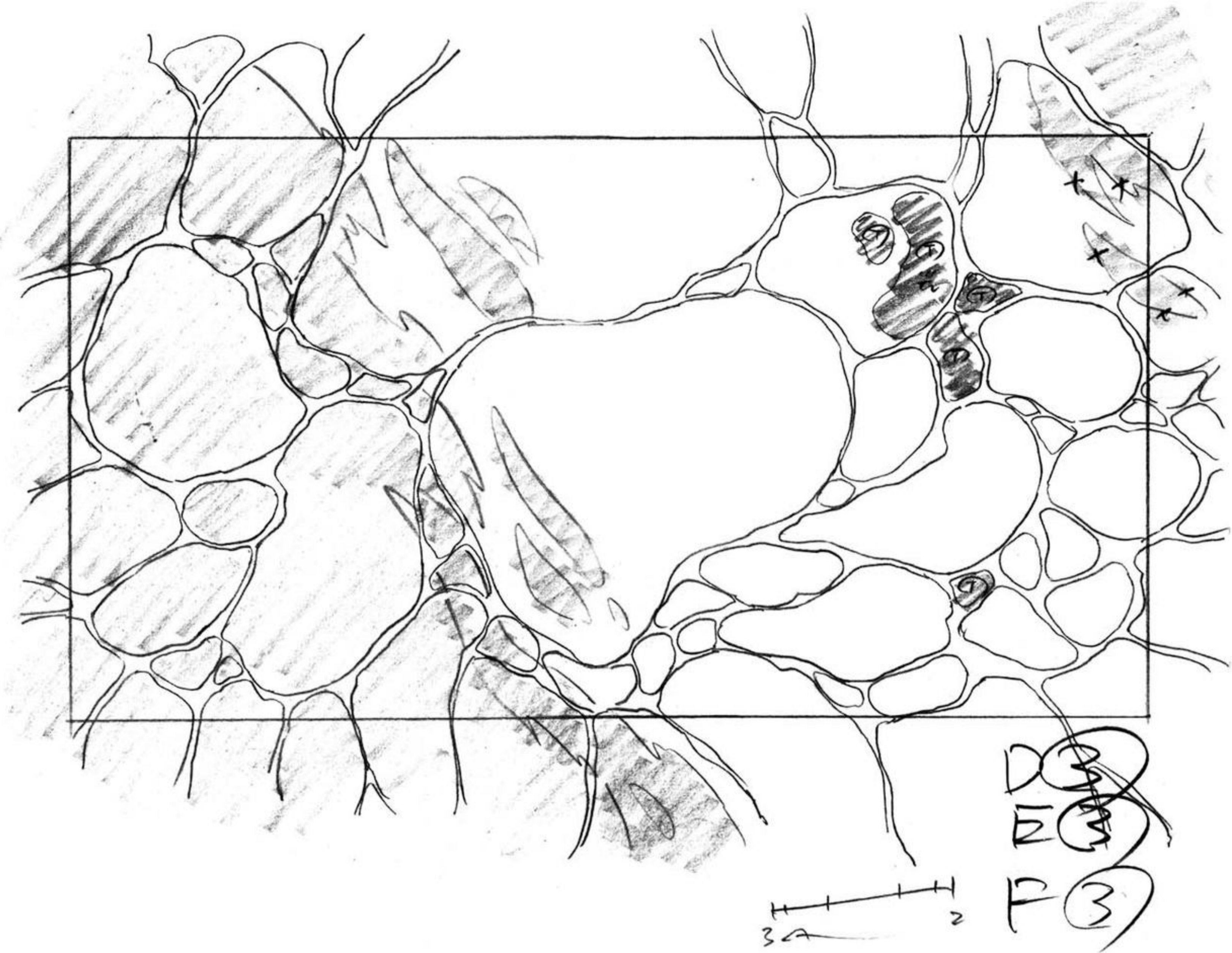

修正原画



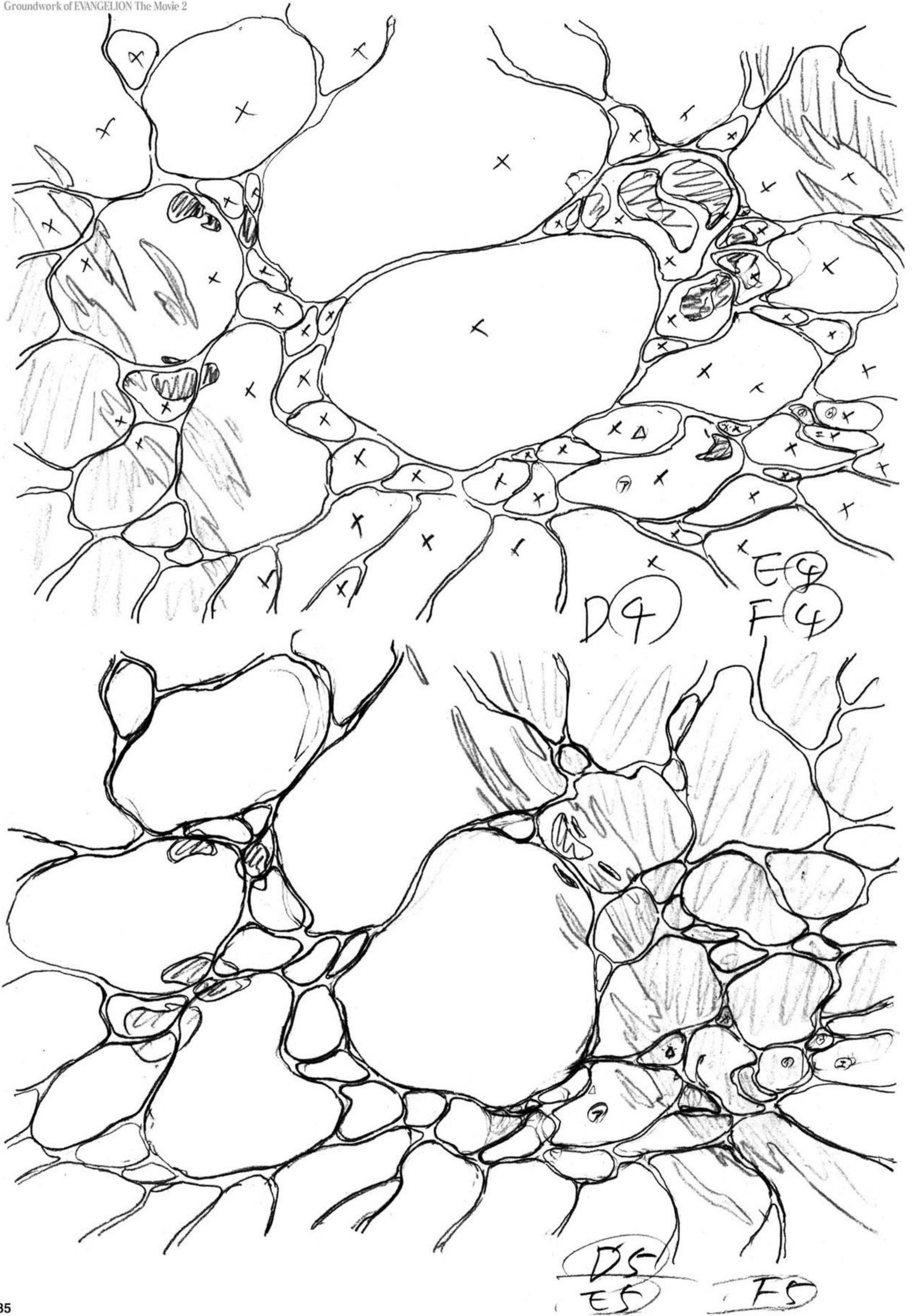



#26-C413

修正原画





修正原画

③ ← C1
year ←



D(2)

C(2)

修正原画

A	B	C	
0	0	0	
1	1	1	2
2	2	2	4
3	3	3	6
4	4	4	8
5	5	5	10
6	6	6	12
7	7	7	14
8	8	8	16
9	9	9	18
10	10	10	20
11	11	11	22
12	12	12	24
13	13	13	26
14	14	14	28
15	15	15	30

③	/	26
/	/	28
/	/	30
/	/	32
/	/	34
/	/	36
③	/	38
/	/	40
/	/	42
/	/	44
/	/	46
/	/	48
③	/	50
/	/	52
/	/	54

⑤	/	50
/	①	52
/	/	54
/	/	56
/	/	58
/	/	60

タイムシート





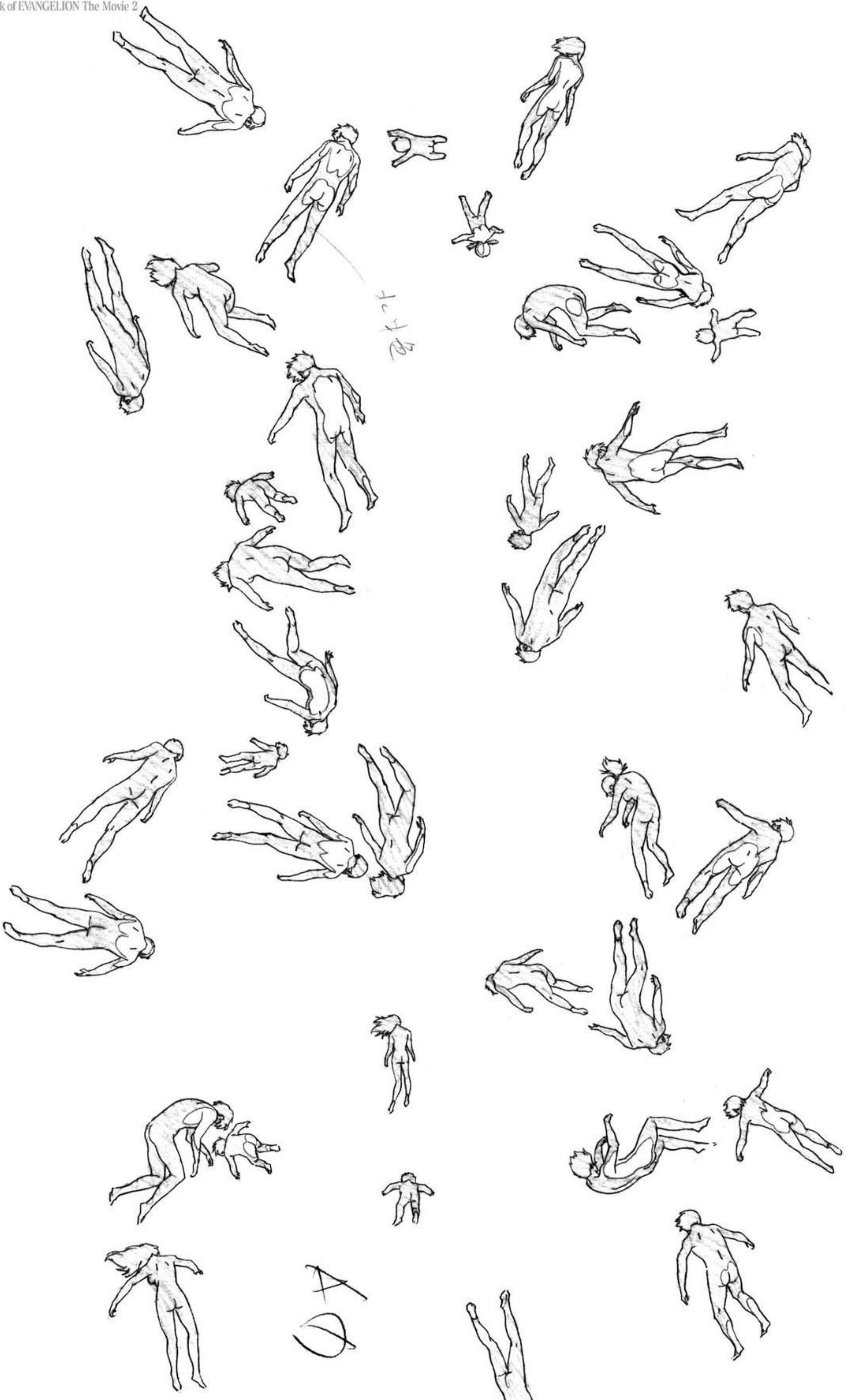

#26-C417,419

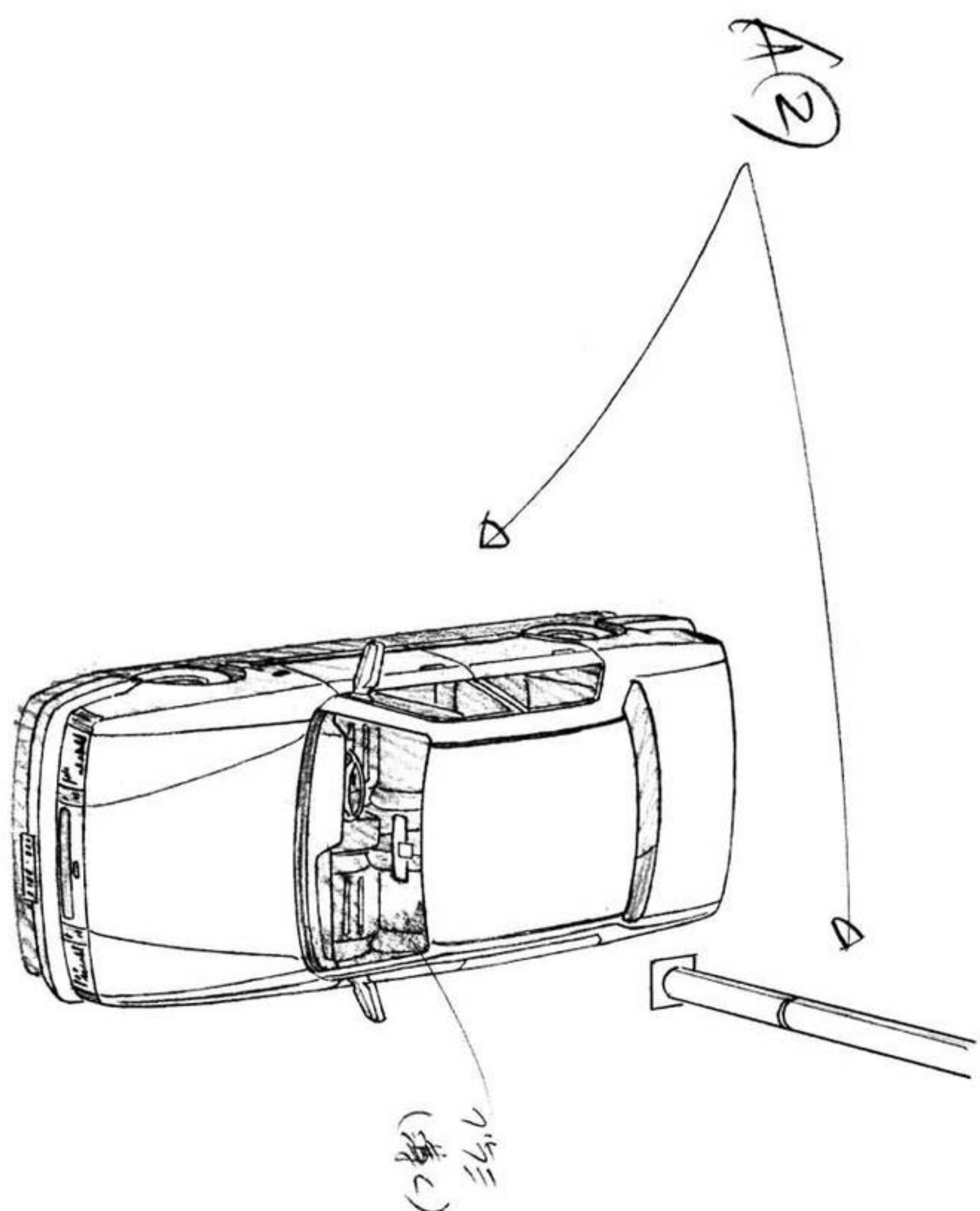
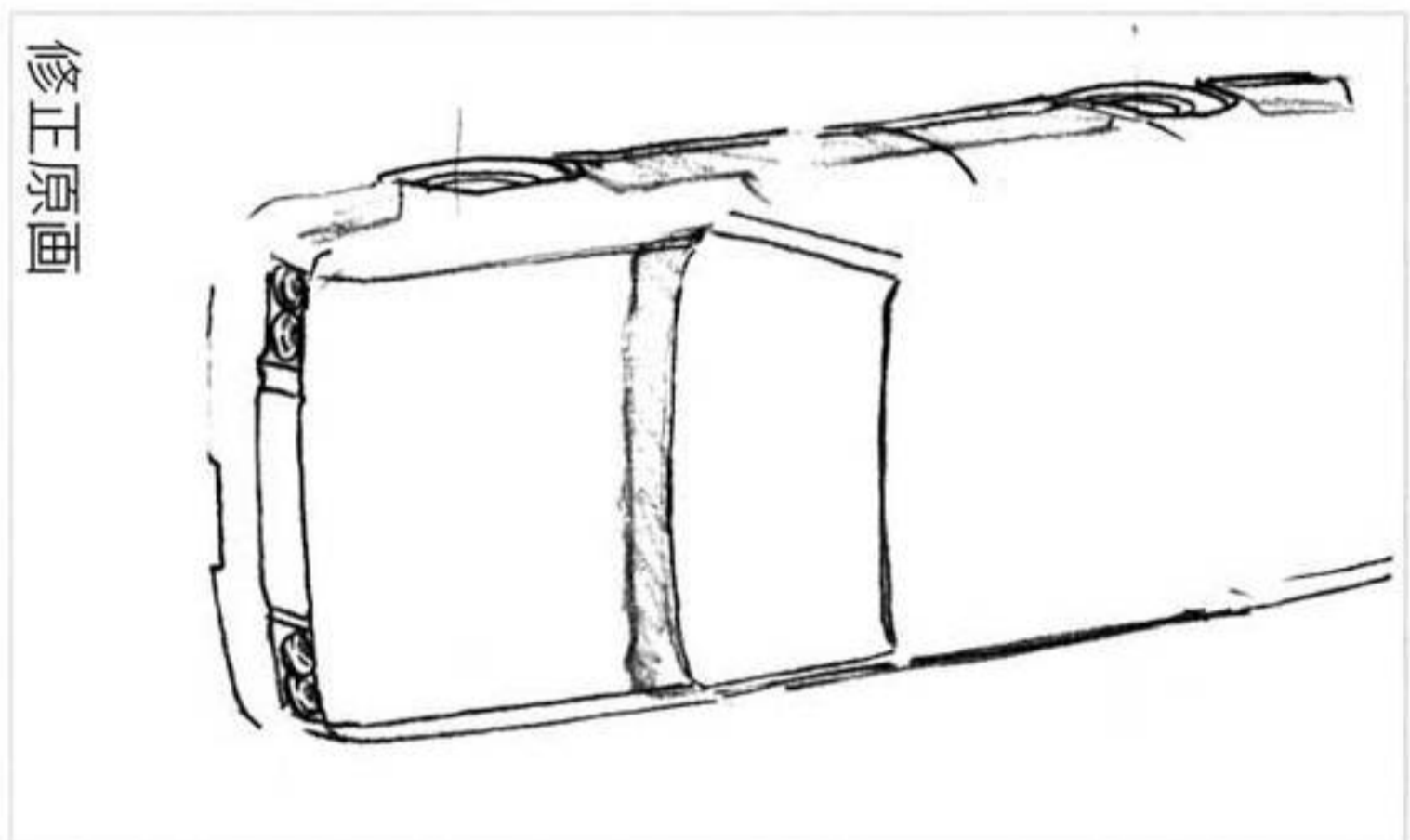
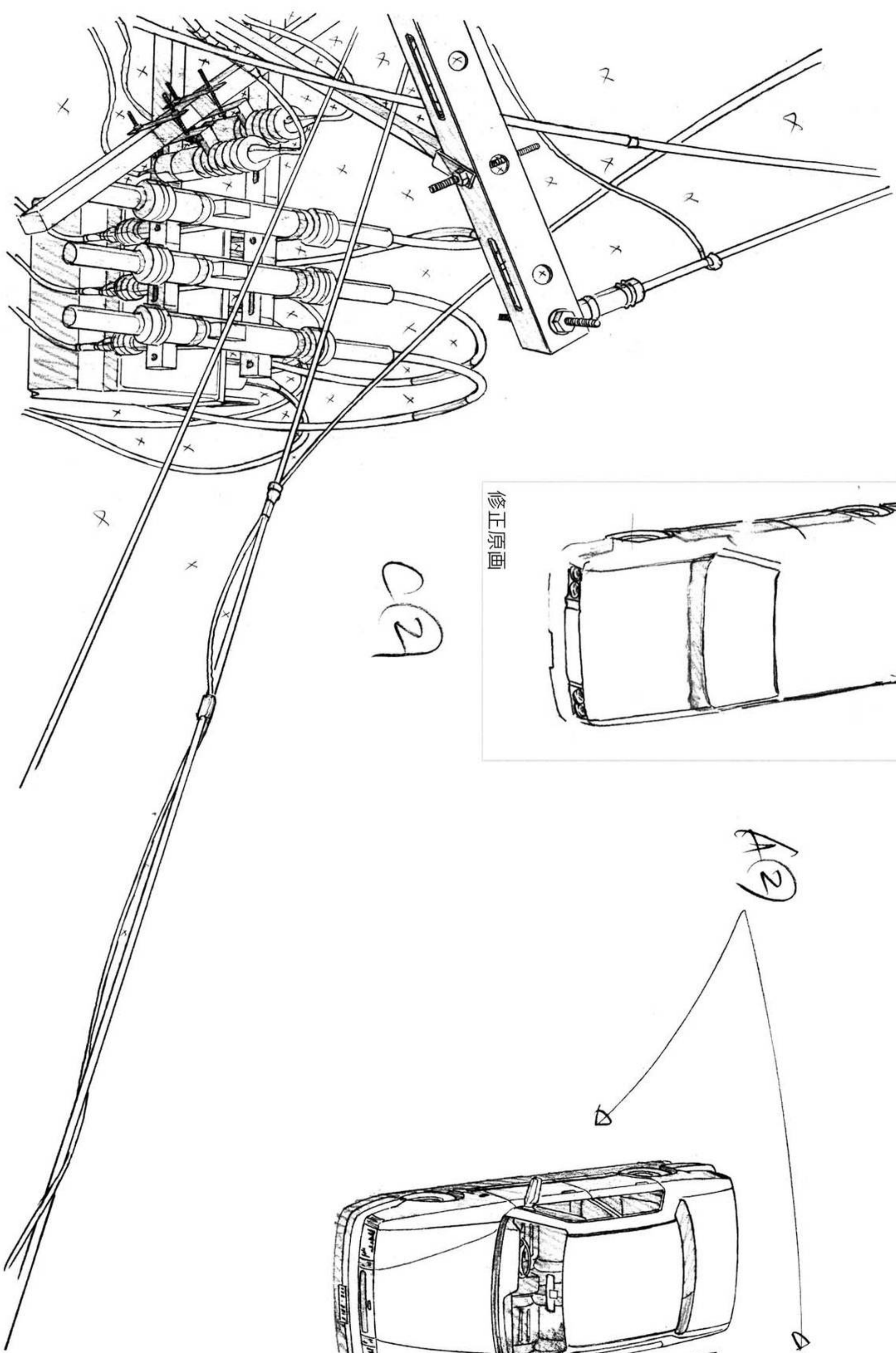

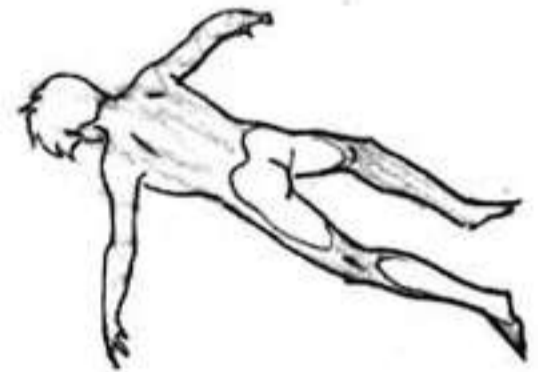
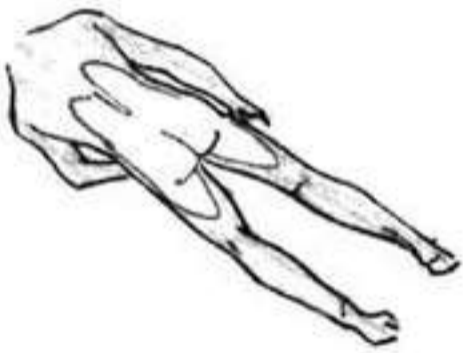
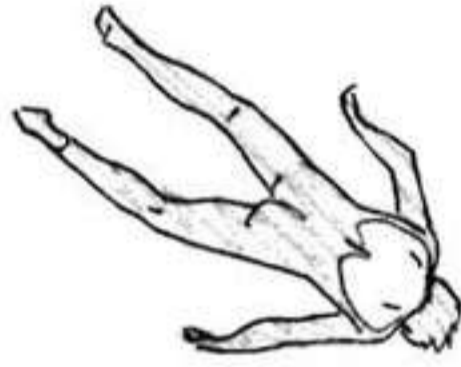

30

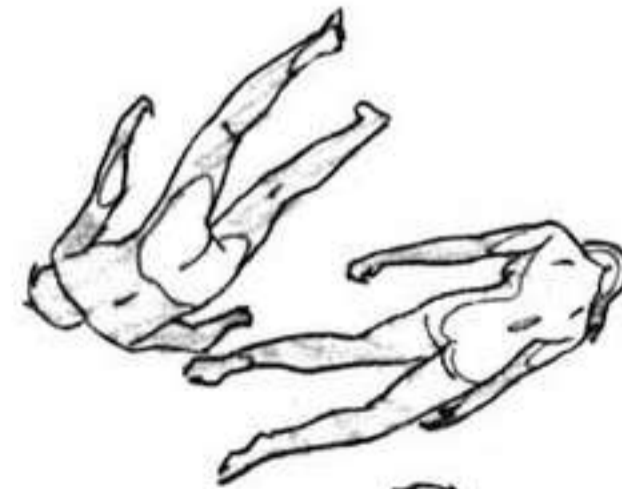

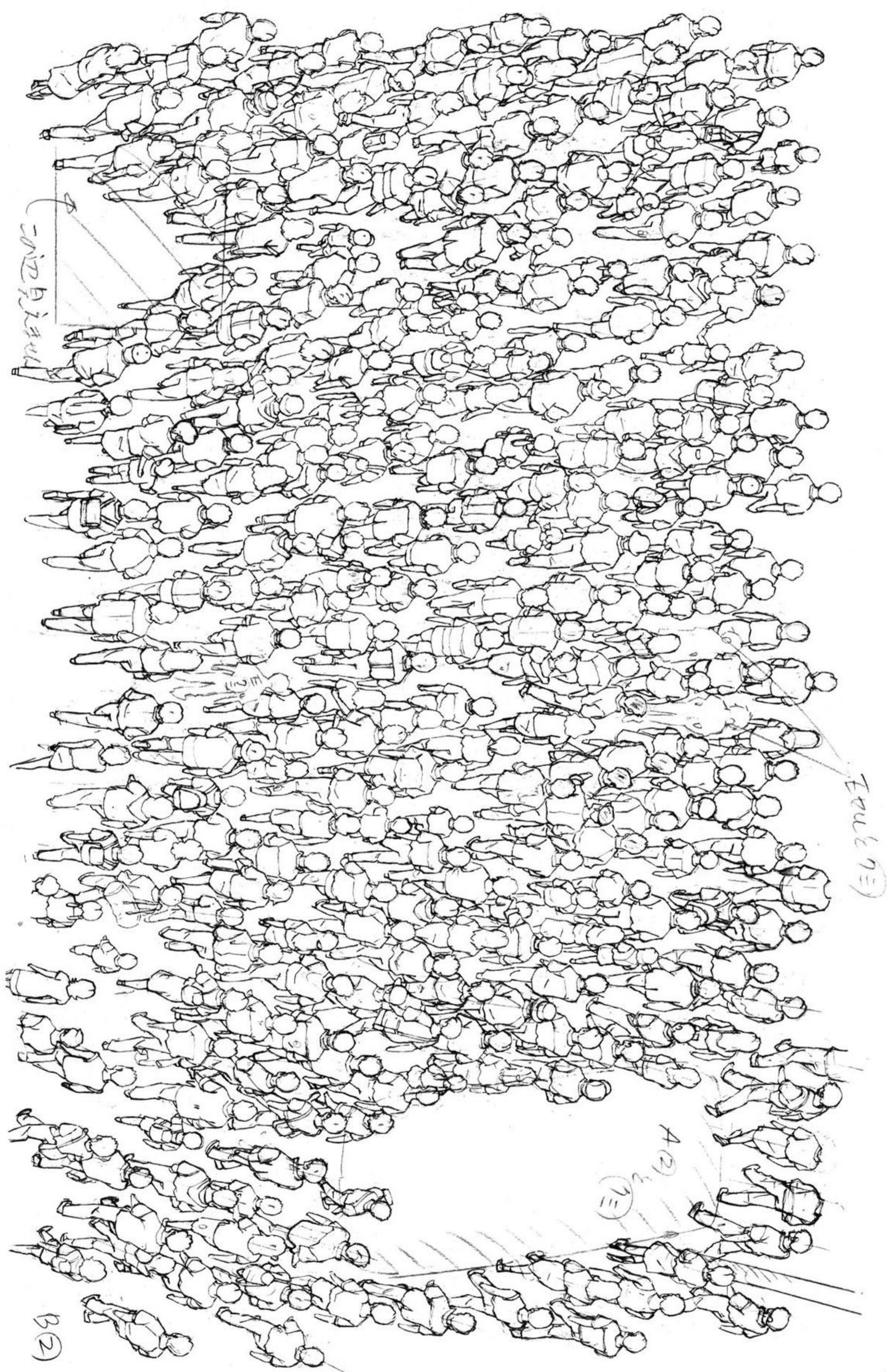

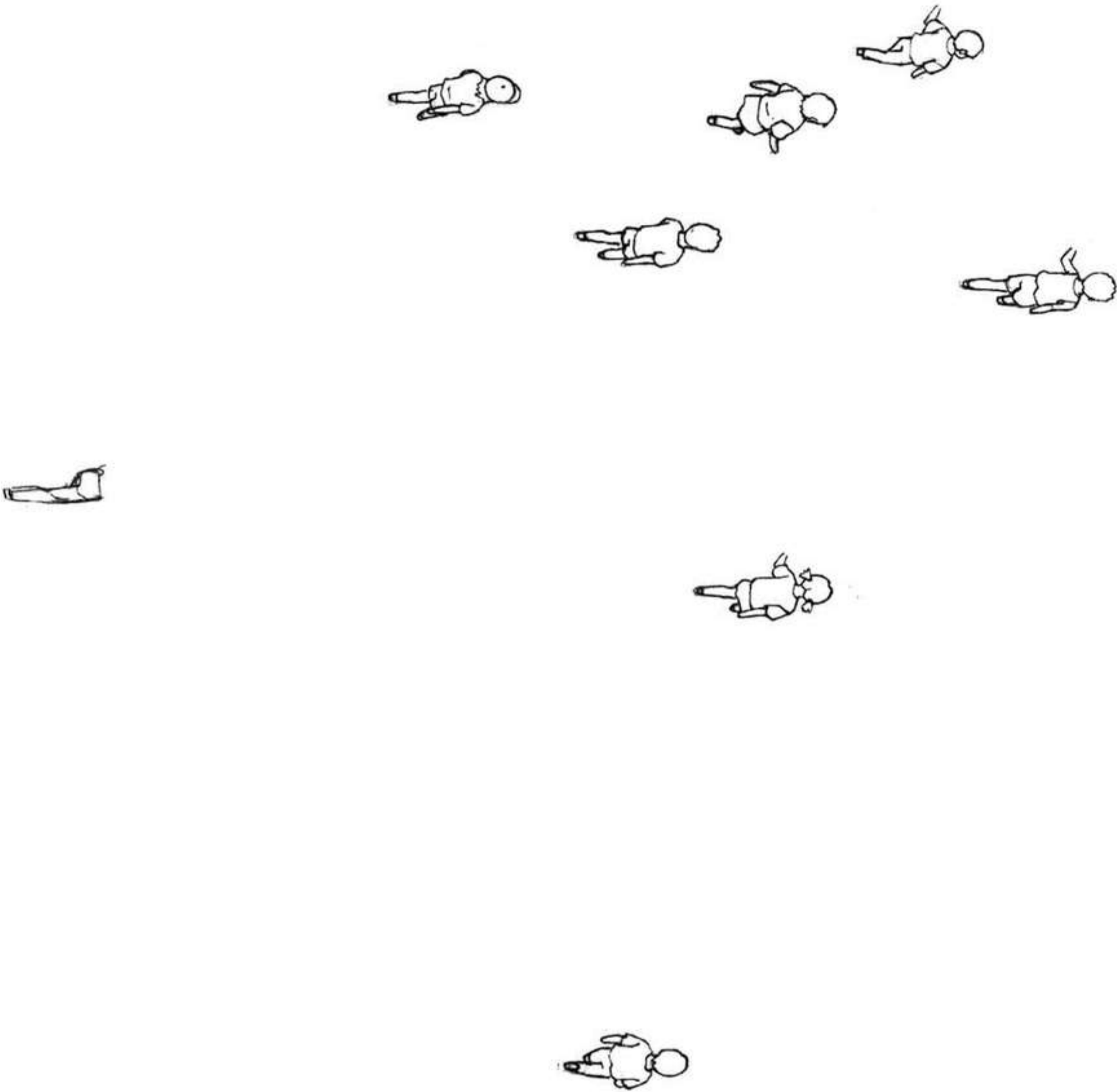

☆子供運動中.
 歩き出す様子. 遠くへ行く様子.

B 2'

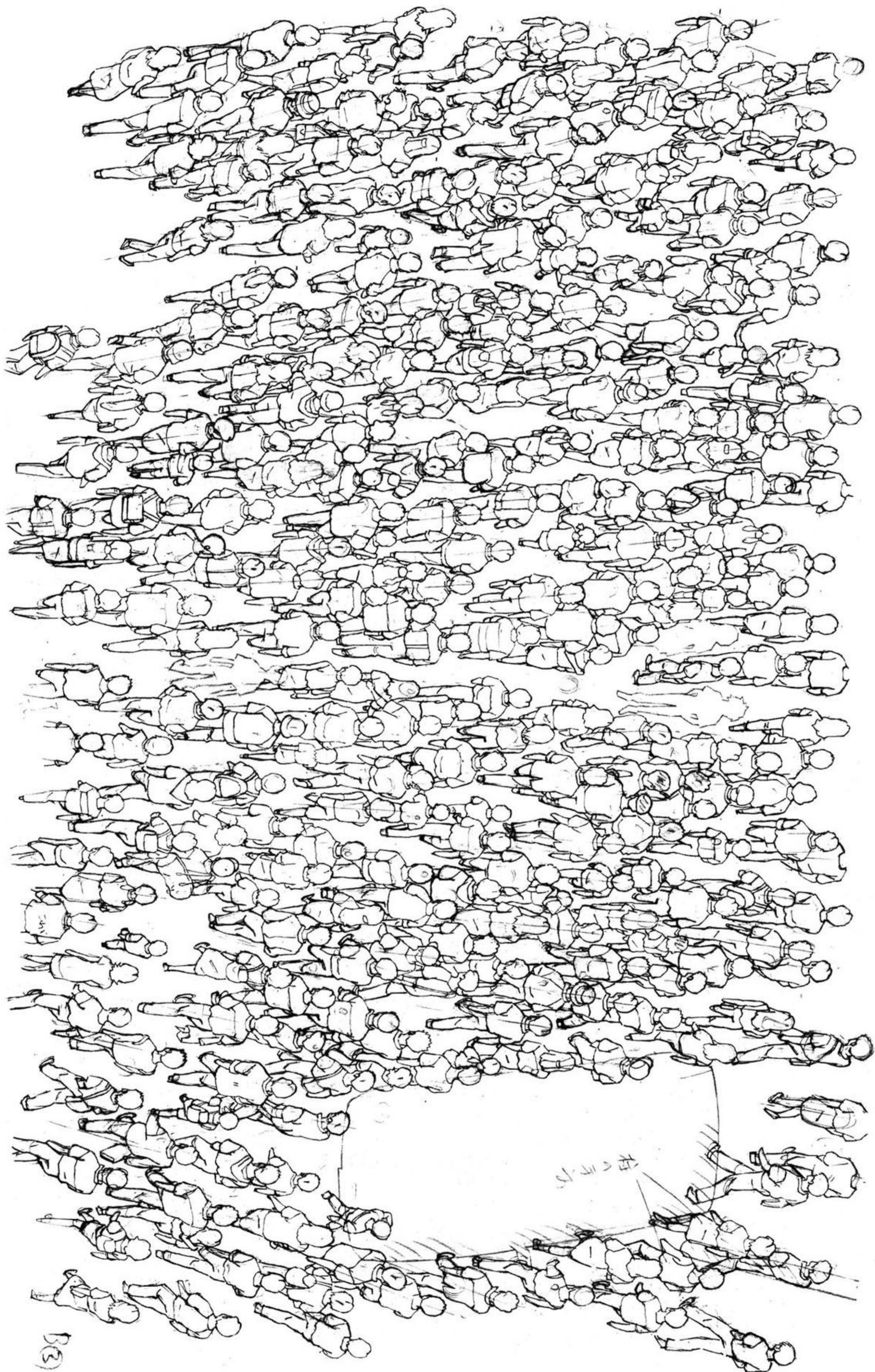

13

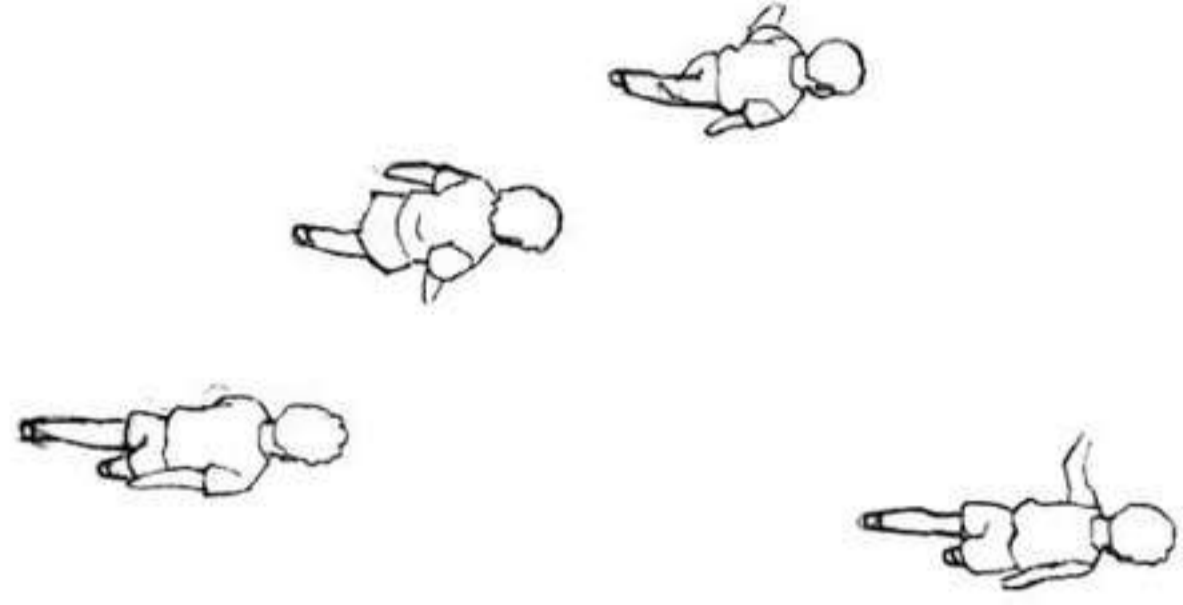

B 3 -

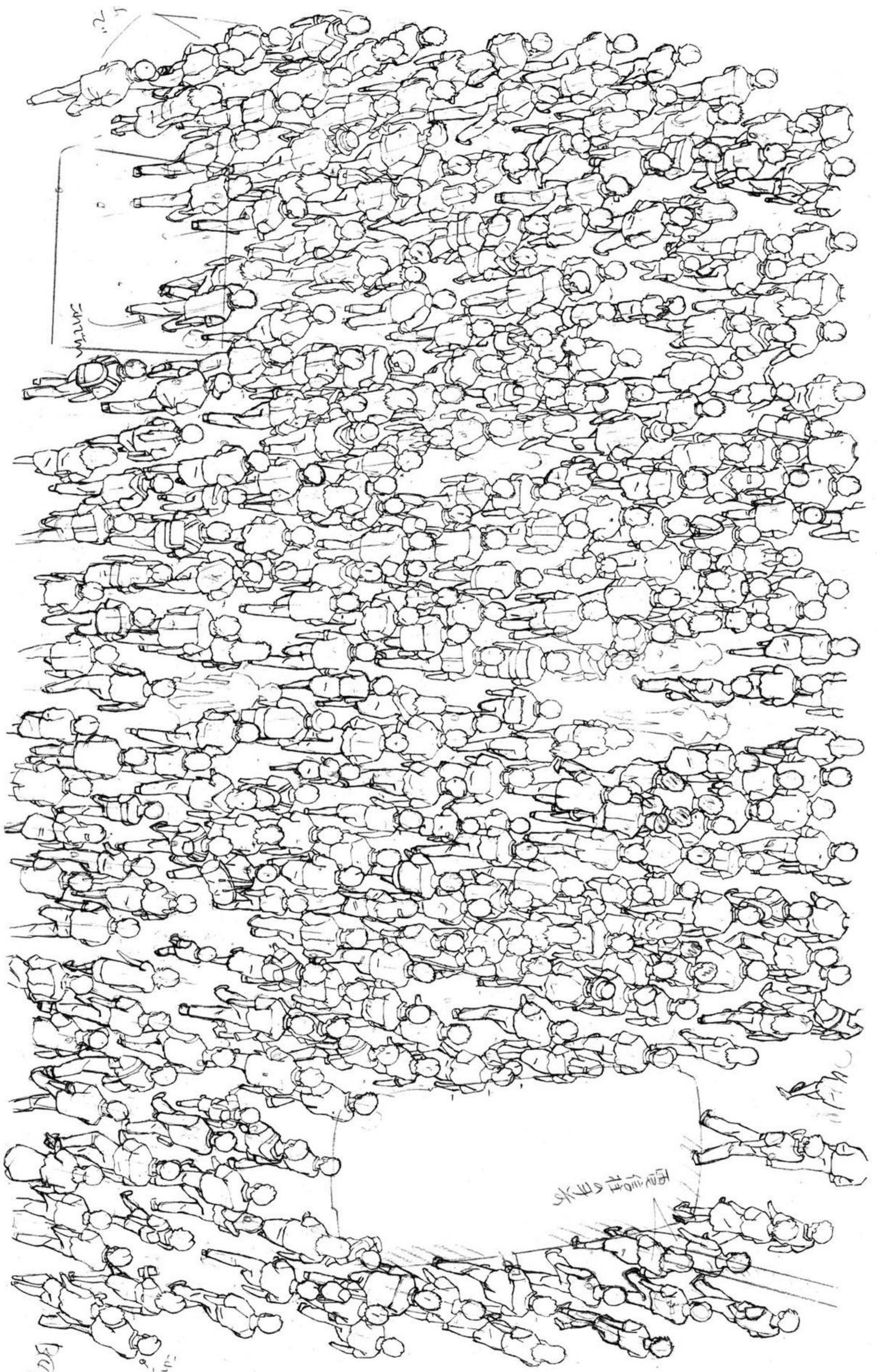

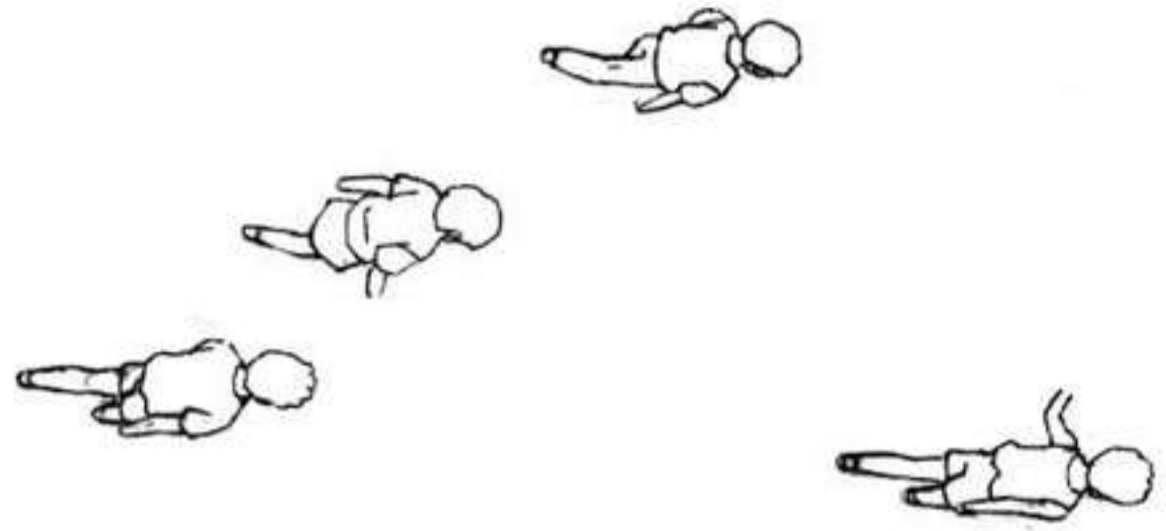

B 4,

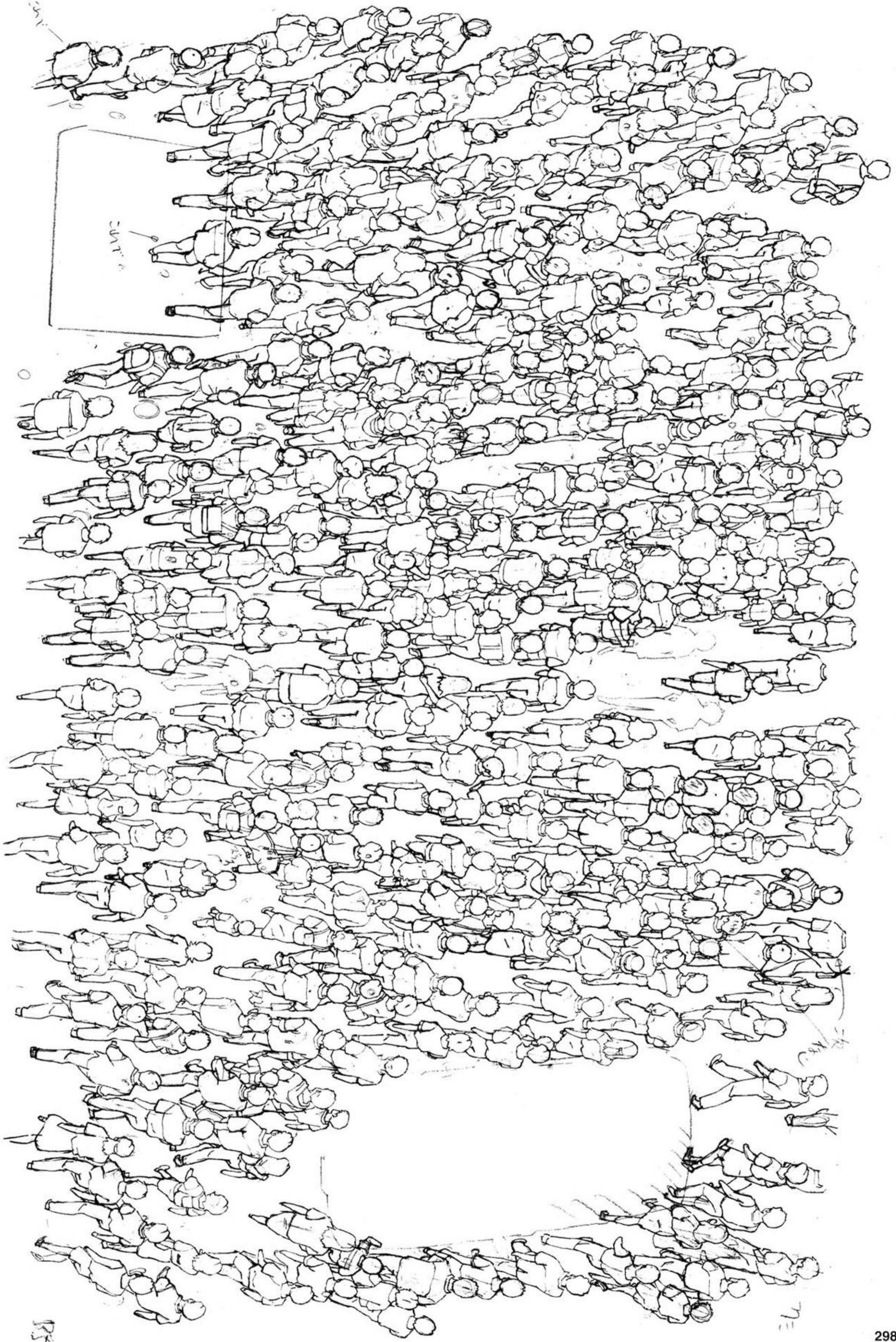

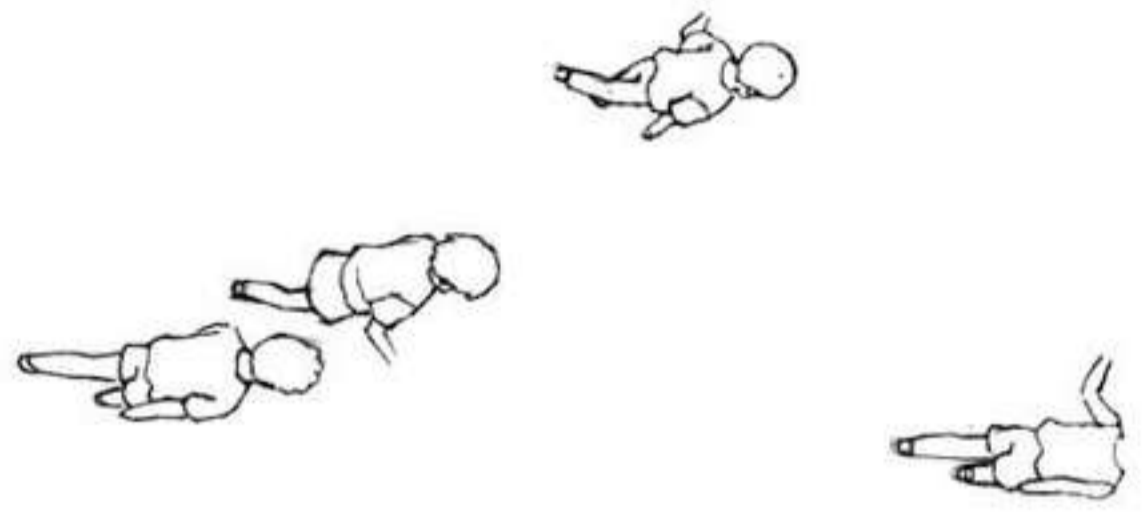

BF ✓

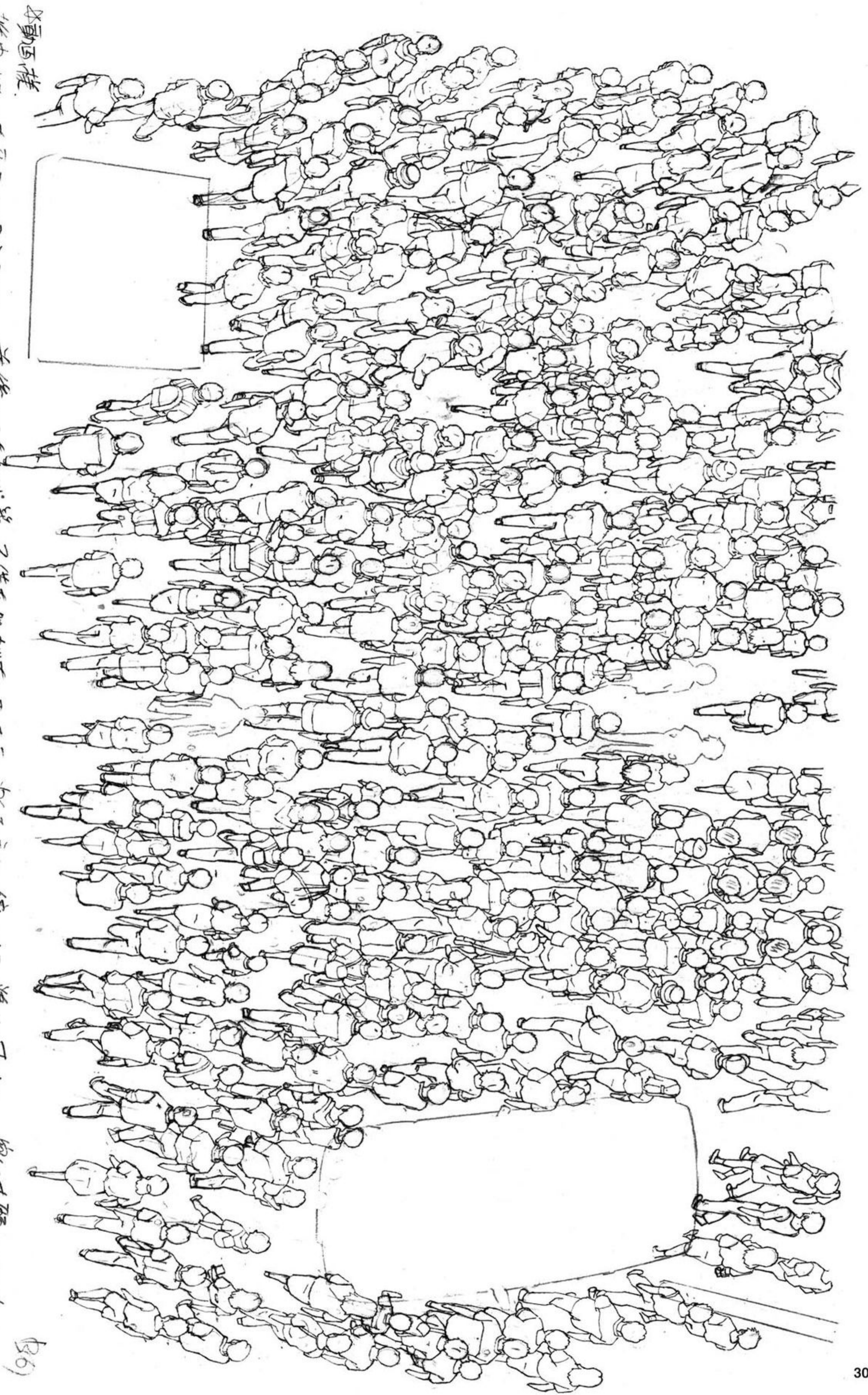

本動向様
雑巾の存在原画でミミズ、前後の方向等、不備な処が有ります、楽な方へ統一して進めたい、宜しく願います。

(B6)

A1

#26-C418,420

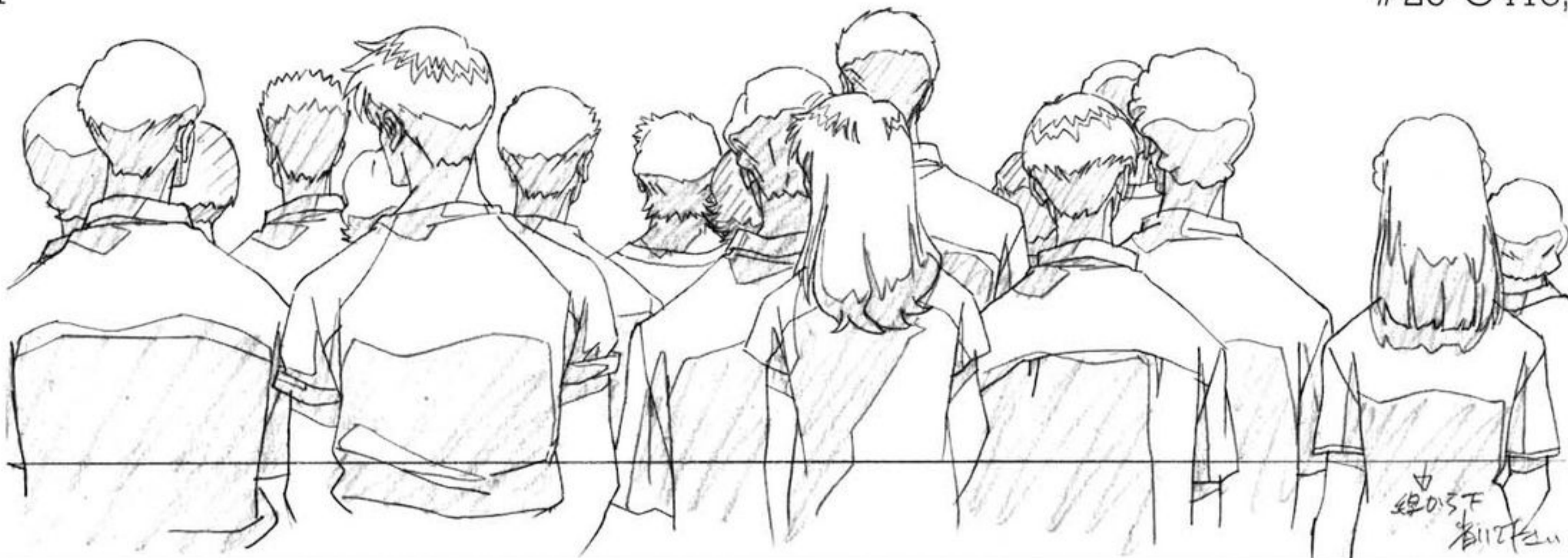

A3



A4

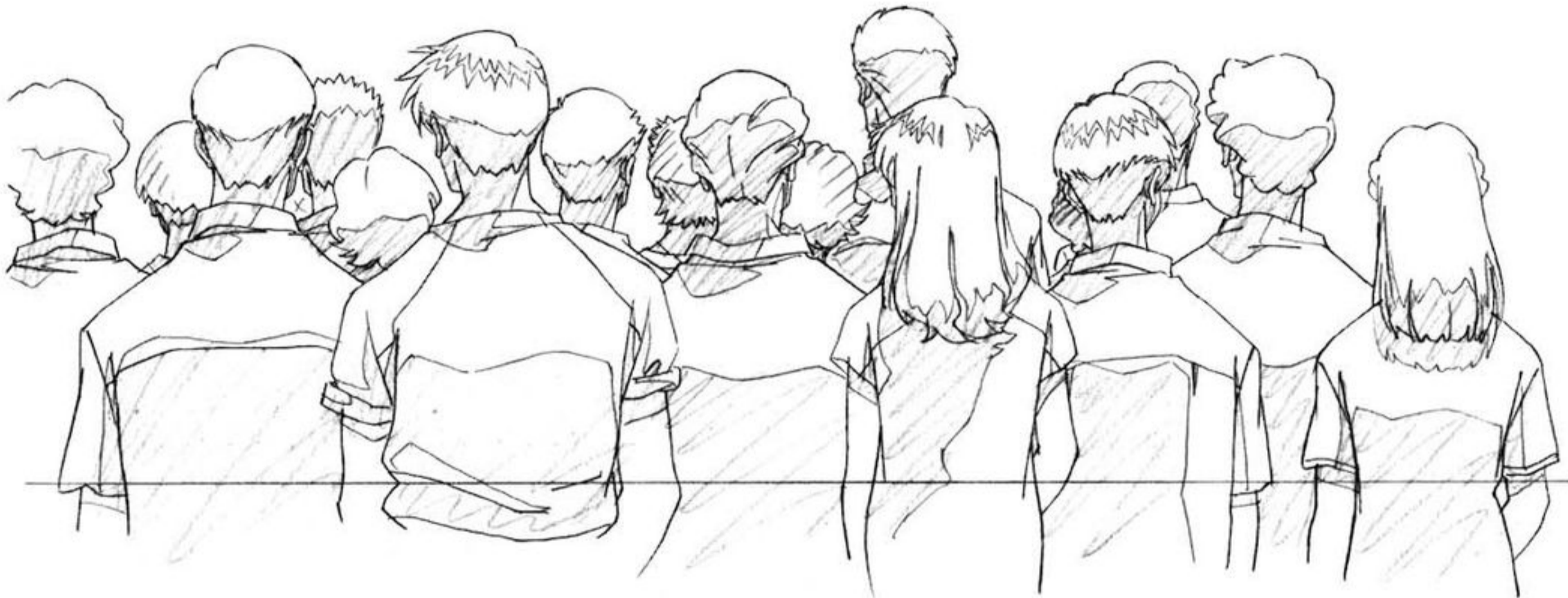

A4参考



B1

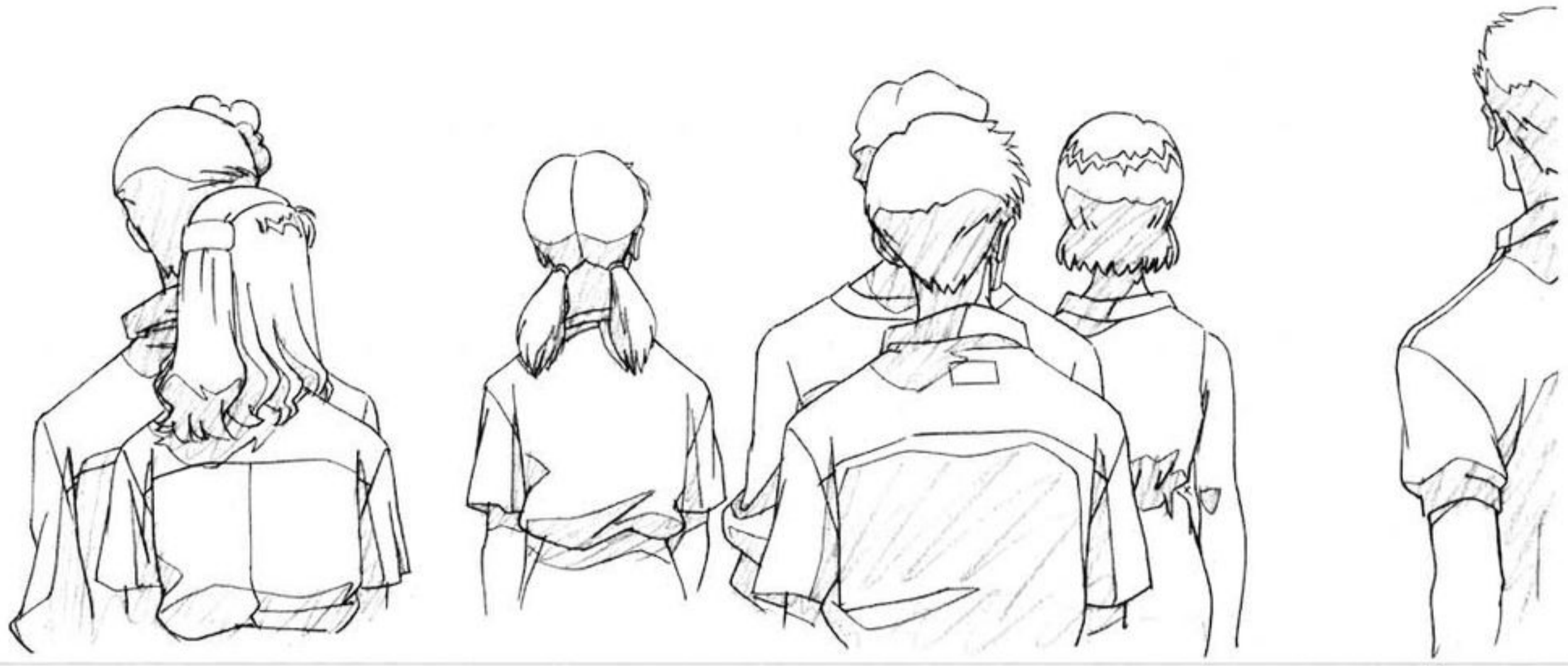

B3



B4



B5



C1



C3



C4



C5



D ef



en7
E0.23



修正原画



修正

E0.23





#26-C421



修正原画



原画
中

(B-1) 12カドニシ



#26-C422

修正原画





A3



修正原画



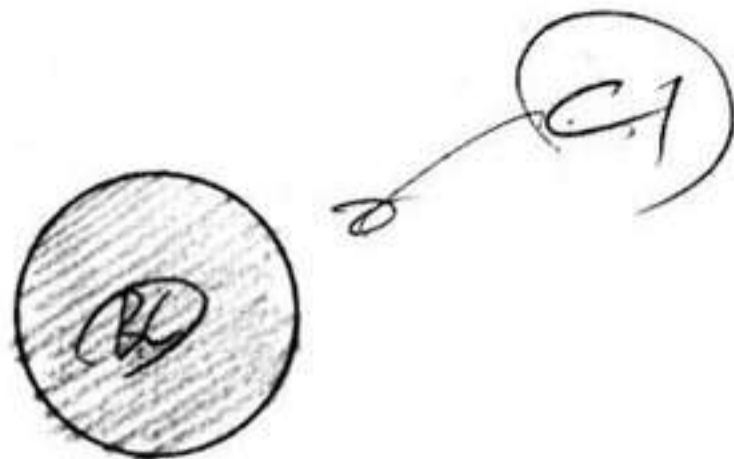

#26-C429

ca B1

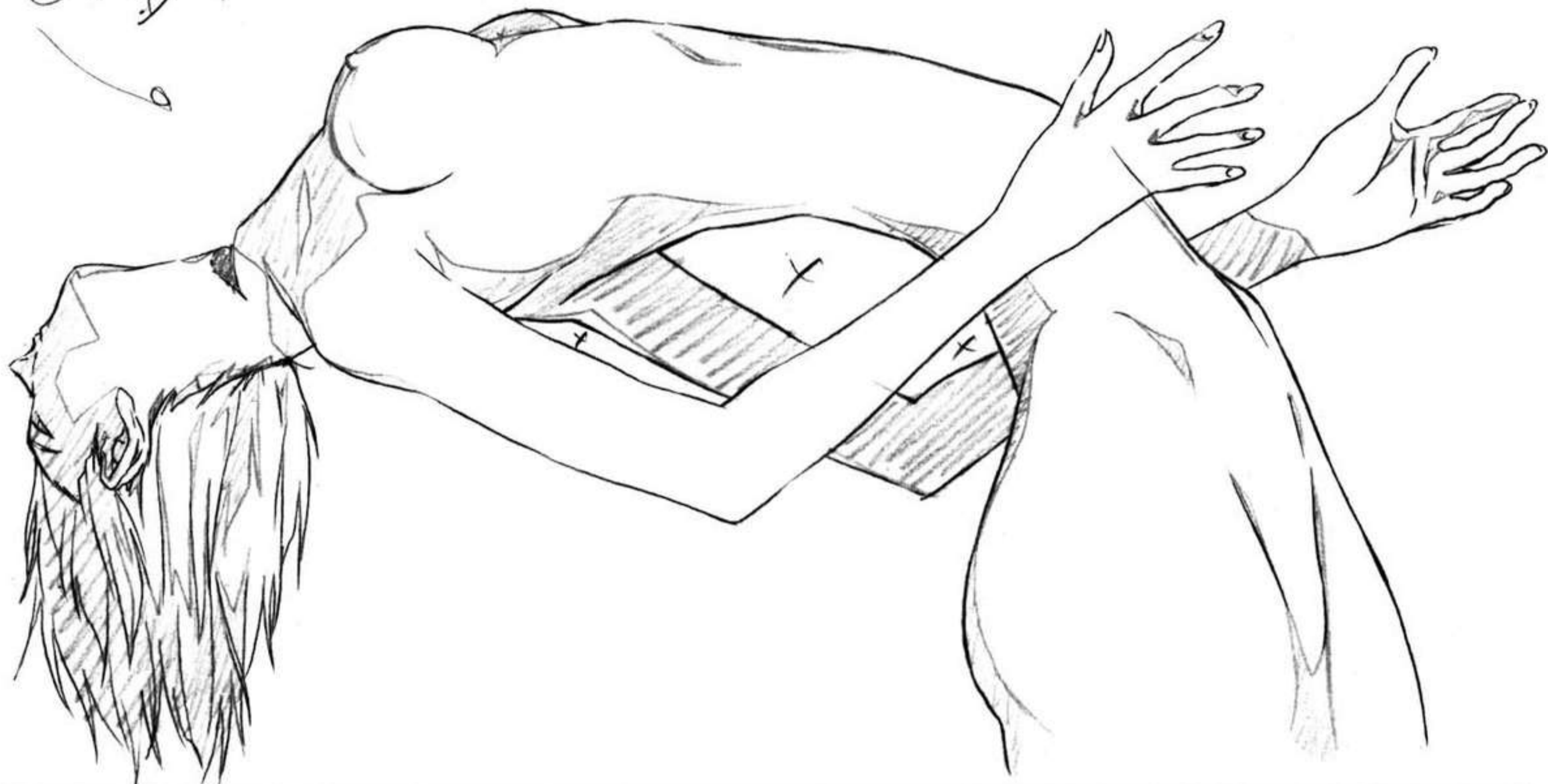

修正原画

Bの絵



B2

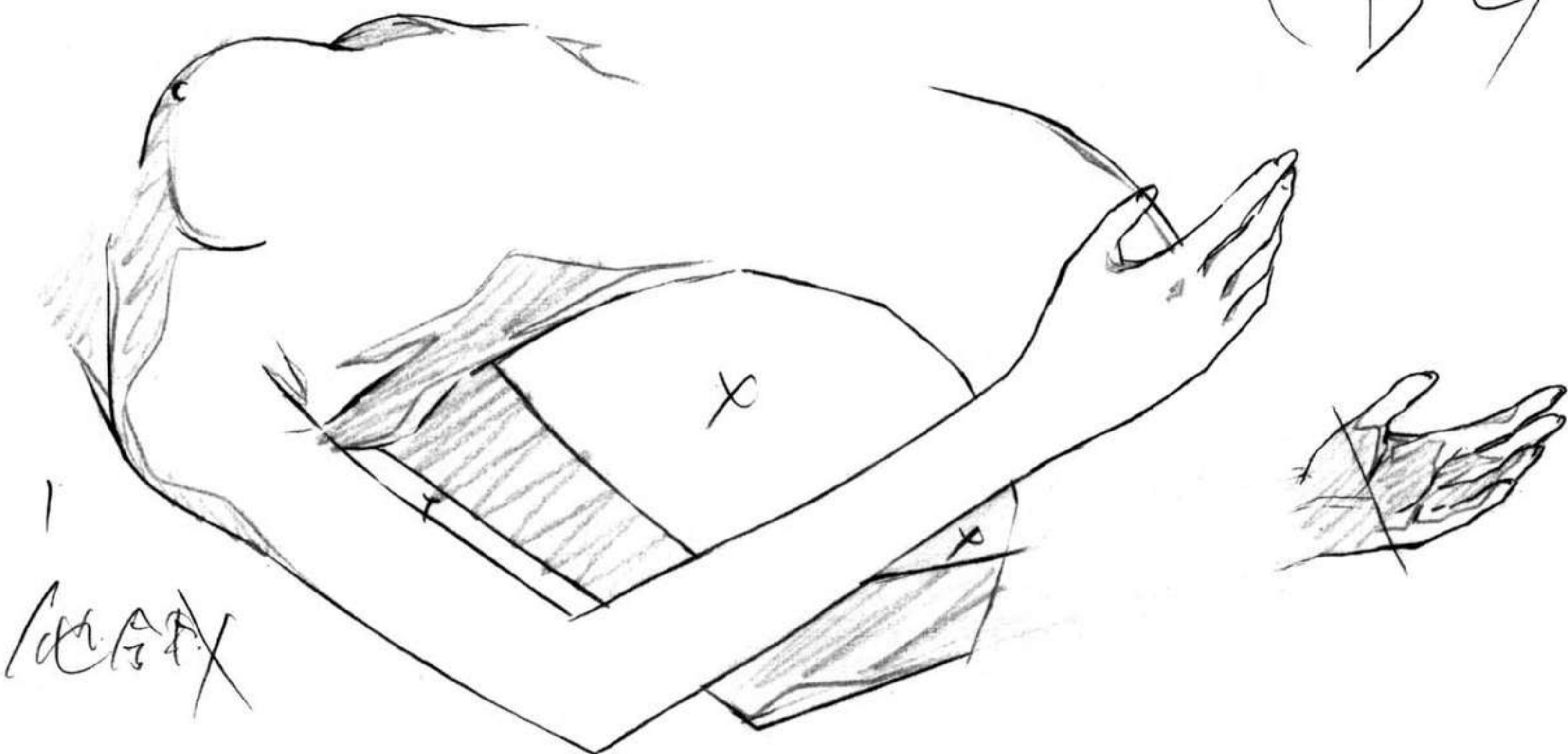

1
他合科

修正原画

B2
1/3

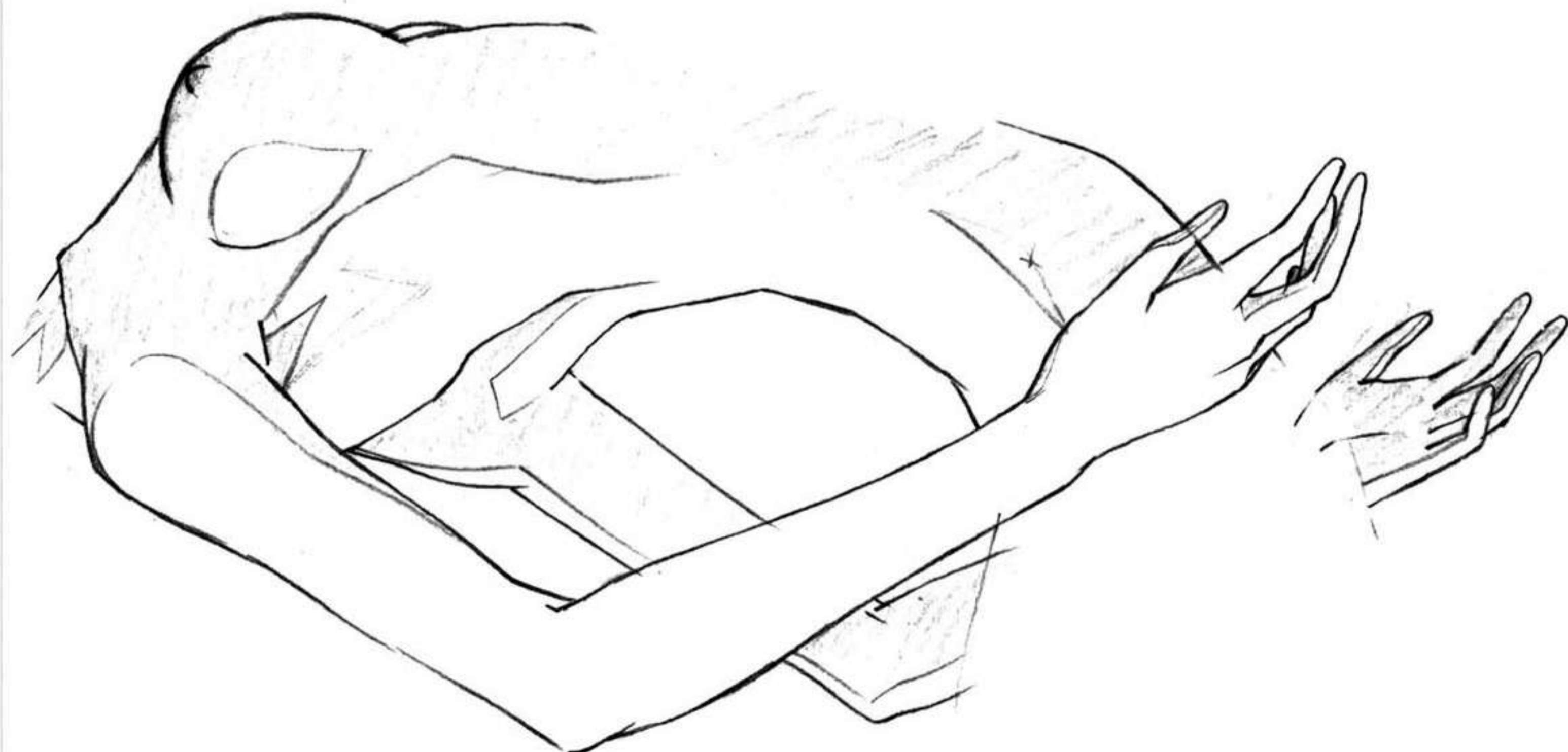



#26-C432



87

74

88

A2



5/5

2A

2B

2C

2D

3



24

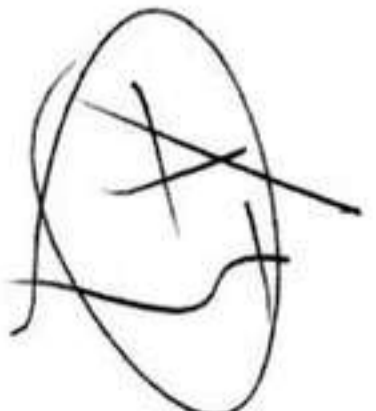
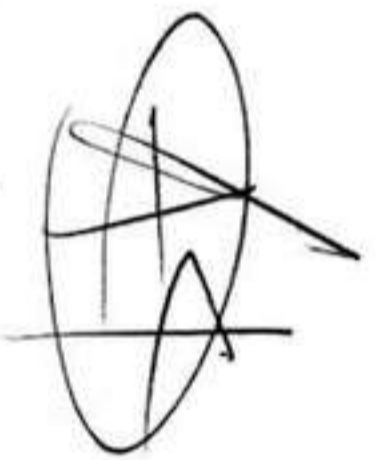



本
線
の
と
に
し
て
の
①
に
一

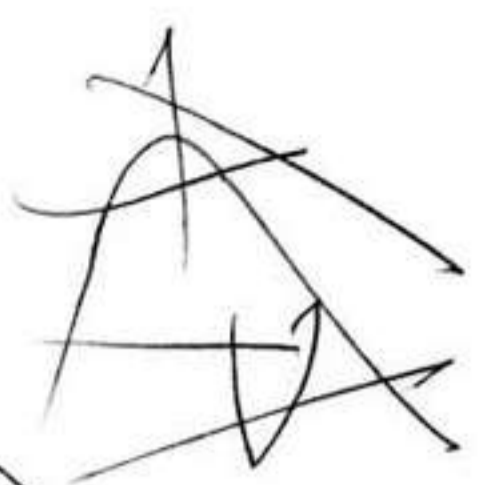

修
正
の
後
の
①
に
一

5/31



5/31



①×この感じを
加えていく



身体別紙有

↓ 参考図

以下

書不用



#26-C433
レイアウト時作監修正

#26-C433



① 1/3 = il
ben

髪
②
③
④
7/11
女
⑤
⑥
⑦
⑧
⑨
⑩
⑪
⑫
⑬
⑭
⑮
⑯
⑰
⑱
⑲
⑳
㉑
㉒
㉓
㉔
㉕
㉖
㉗
㉘
㉙
㉚
㉛
㉜
㉝
㉞
㉟
㊱
㊲
㊳
㊴
㊵
㊶
㊷
㊸
㊹
㊺
㊻
㊼
㊽
㊾
㊿

#26-C445

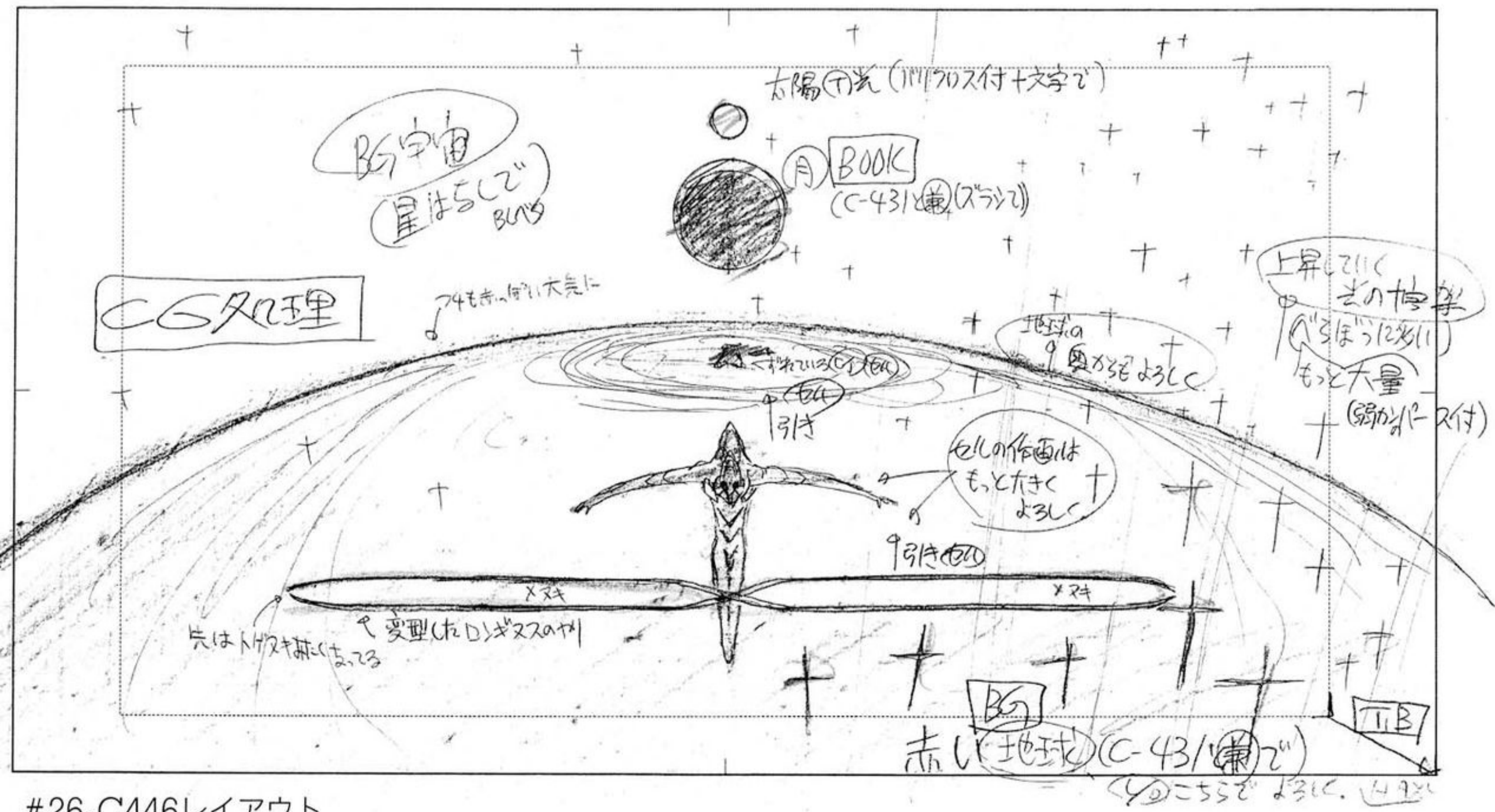
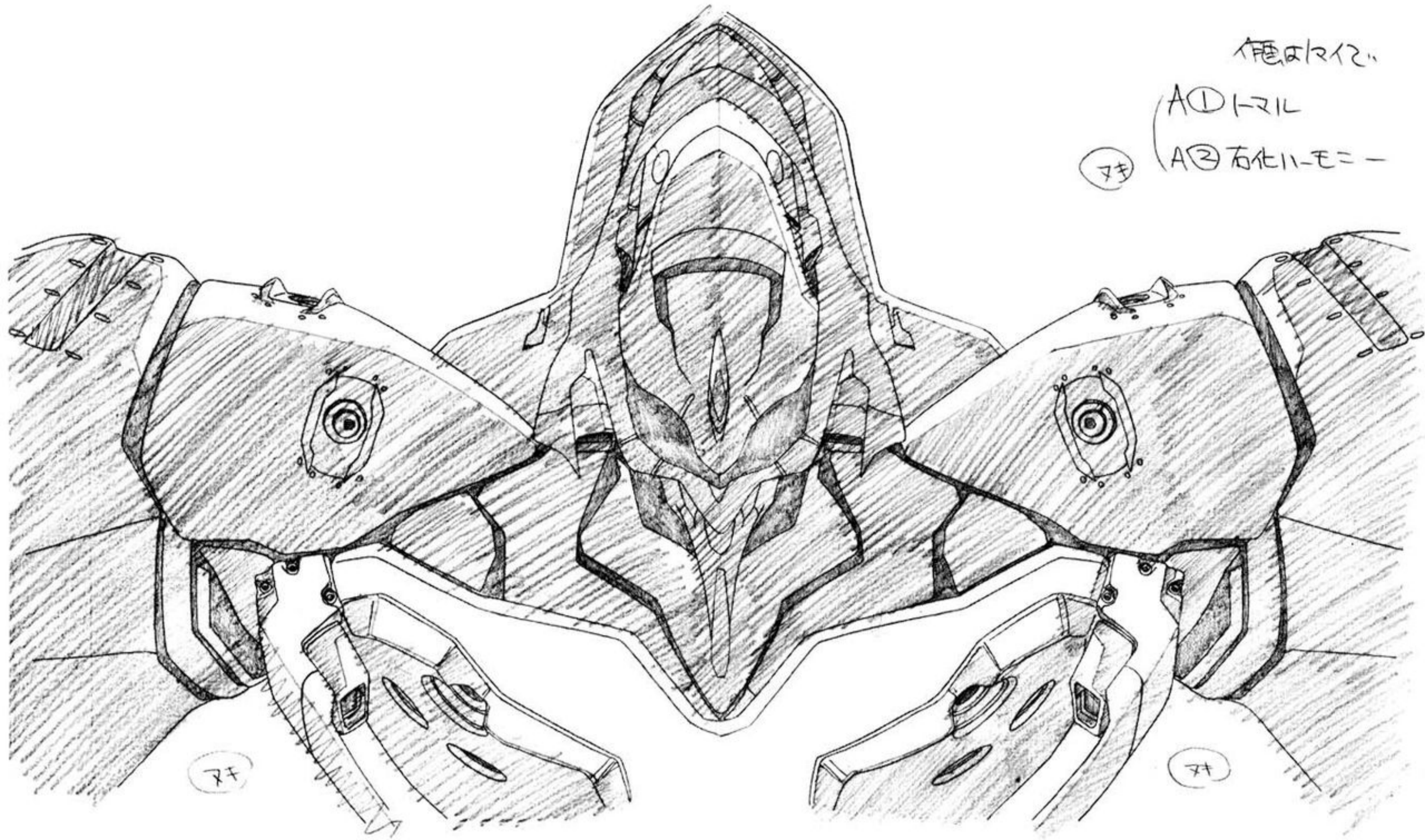

#26-C446レイアウト

Hitsu

#26-C448A



#26-C449

(31)

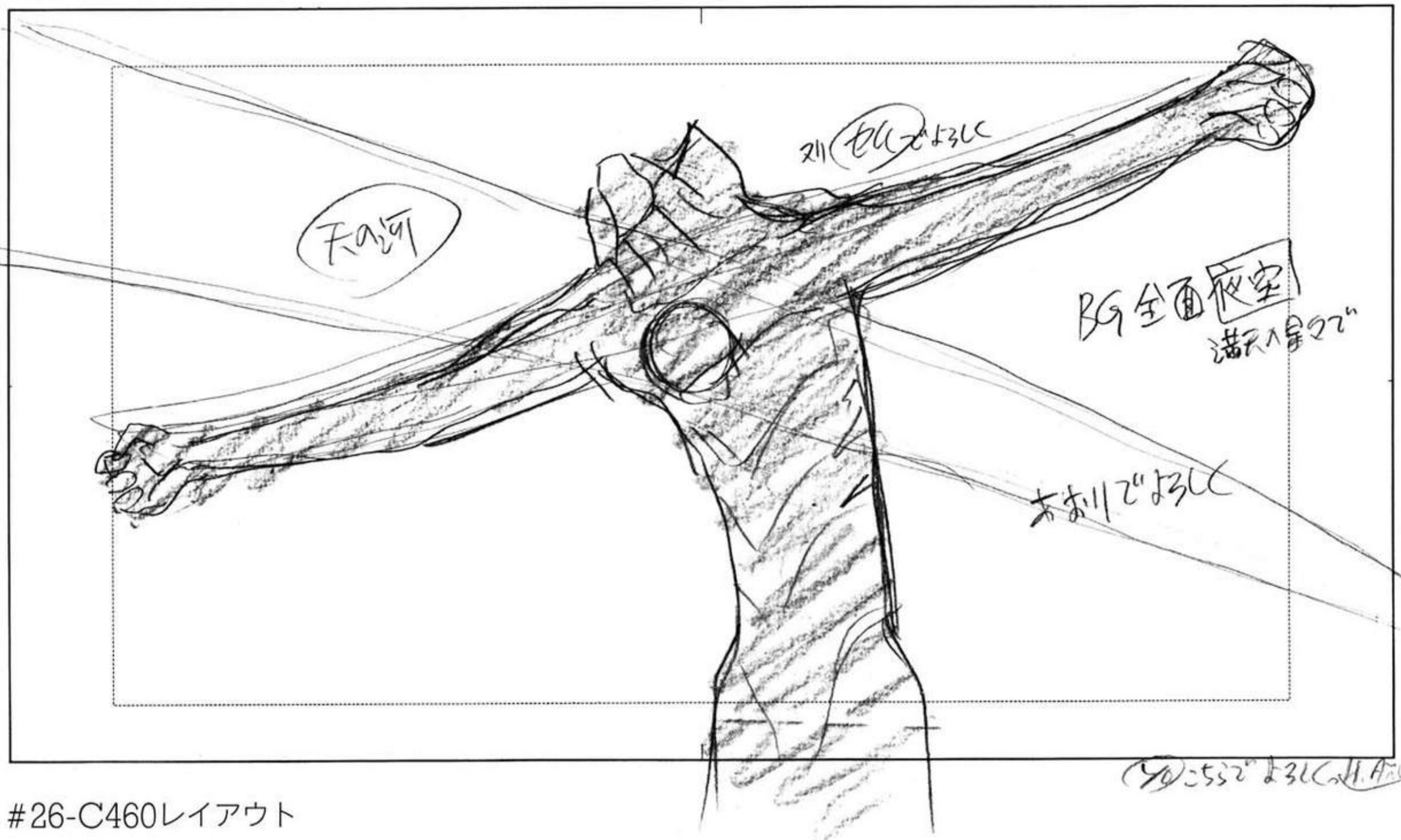

#26-C460レイアウト



#26-C460レイアウト時作監修正

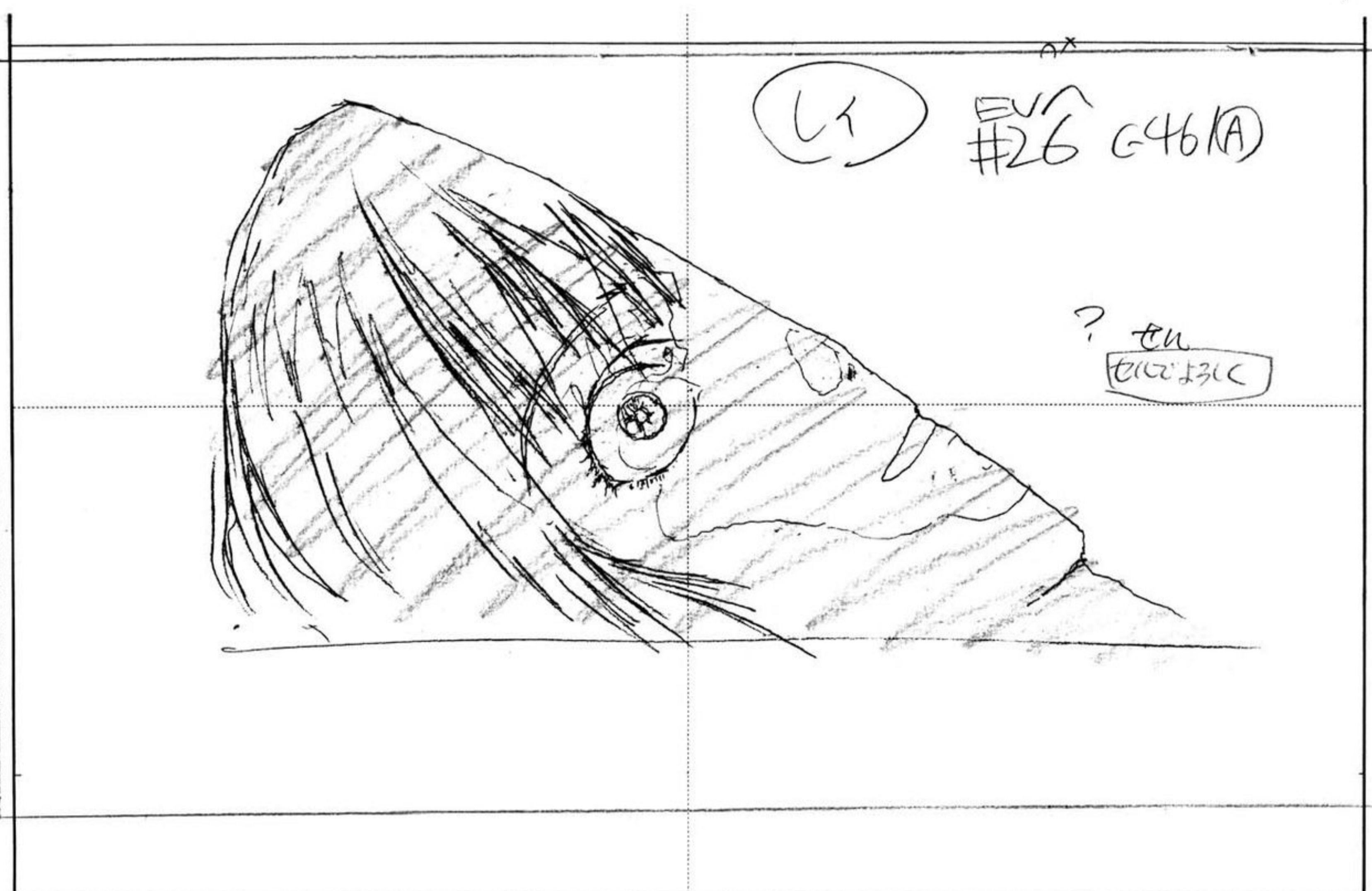
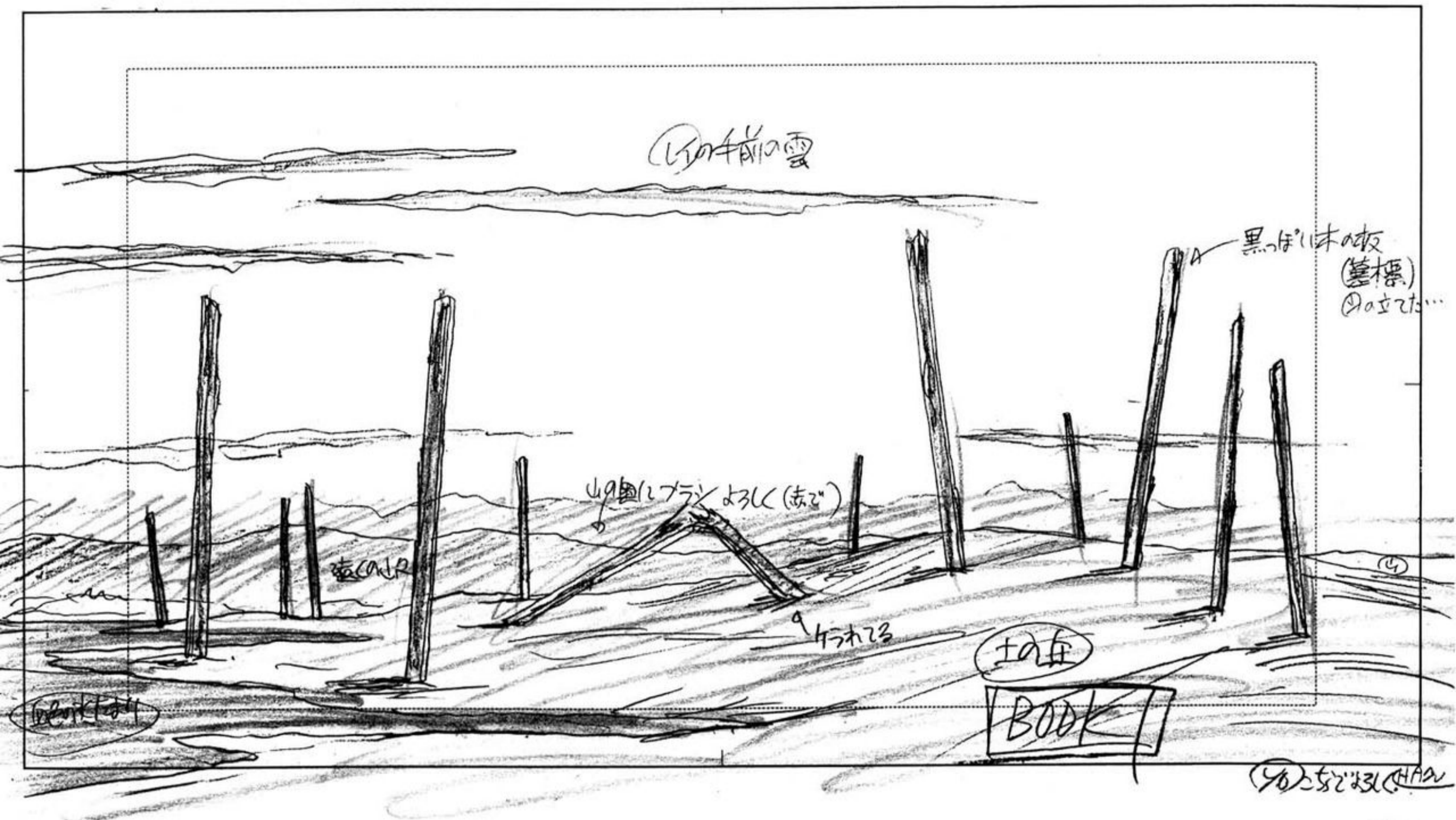

#26-C467,469

A 0



A 1



A(2)



A(3)M2

A(3)



#26-C471A







#26-C477,479レイアウト



#26-C477.479

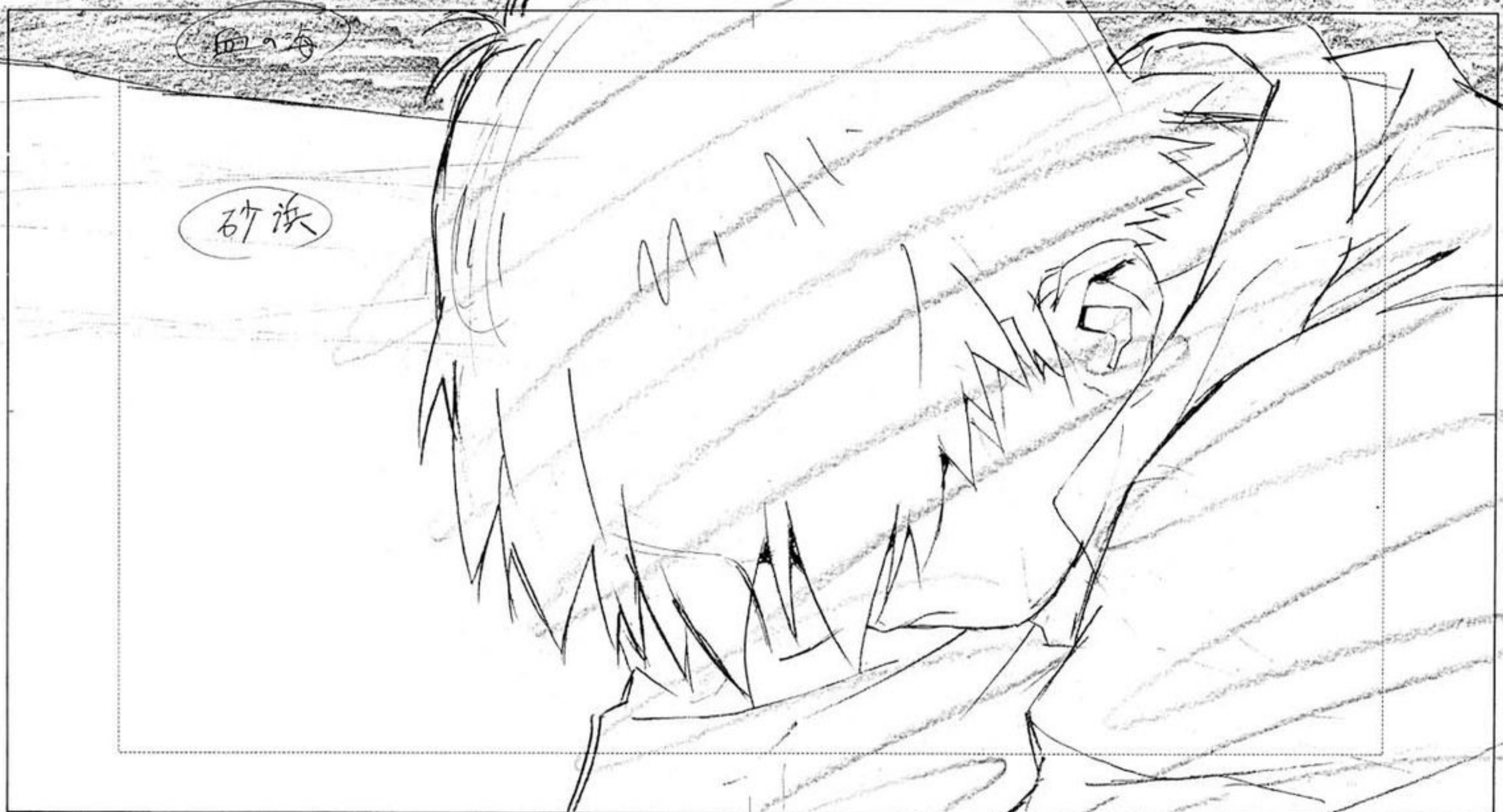

#26-C478レイアウト



#26-C480レイアウト

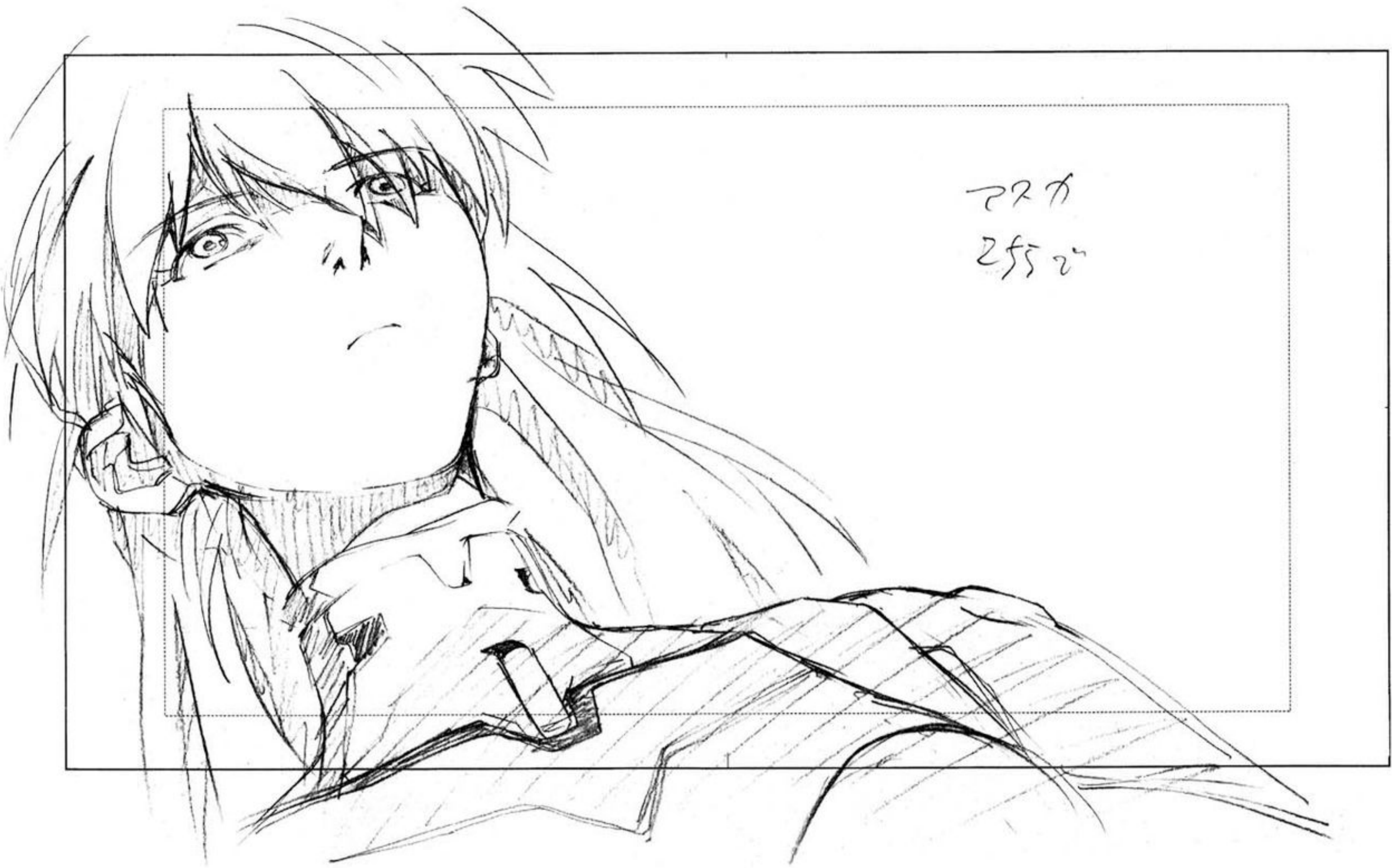

アスカ
255cm

#26-C480レイアウト時作監修正



#26-C480

#26-C473,476,481レイアウト

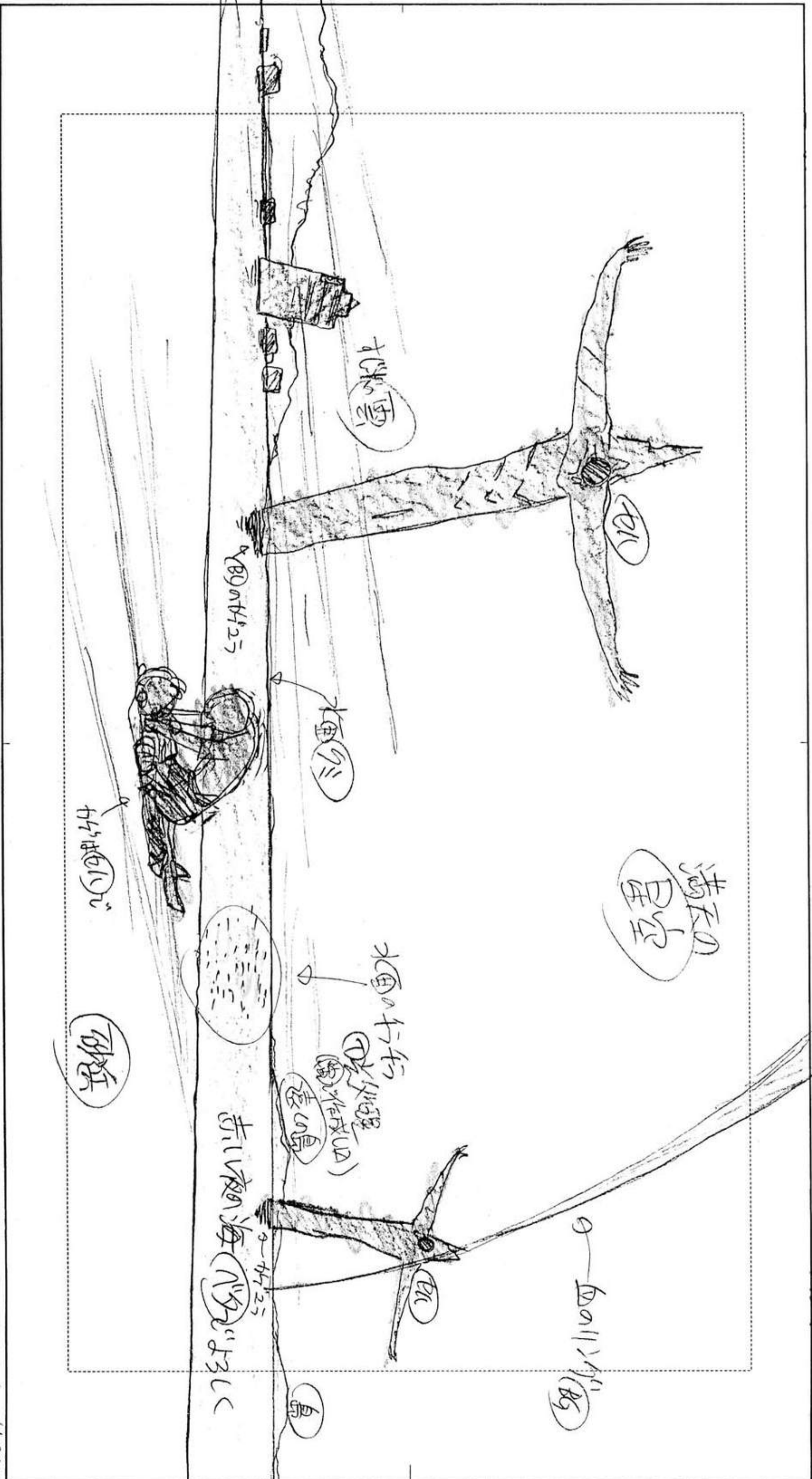

水鏡の行方 (Mizumirai no Yuko) 赤い海 (Akai Umi) N°20 33C

(2)

#26 主タイトルデジタルデータ

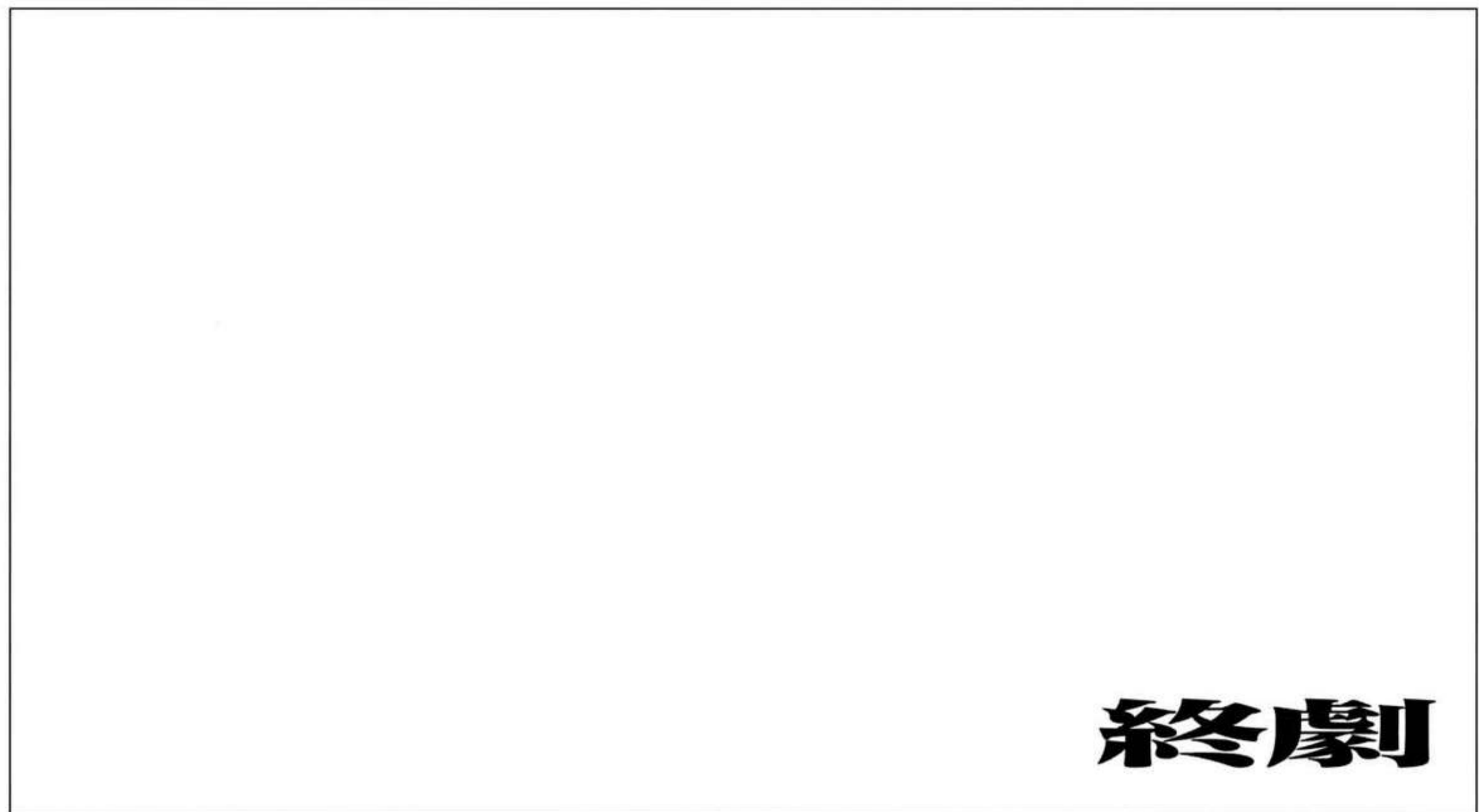

#26 終タイトルデジタルデータ

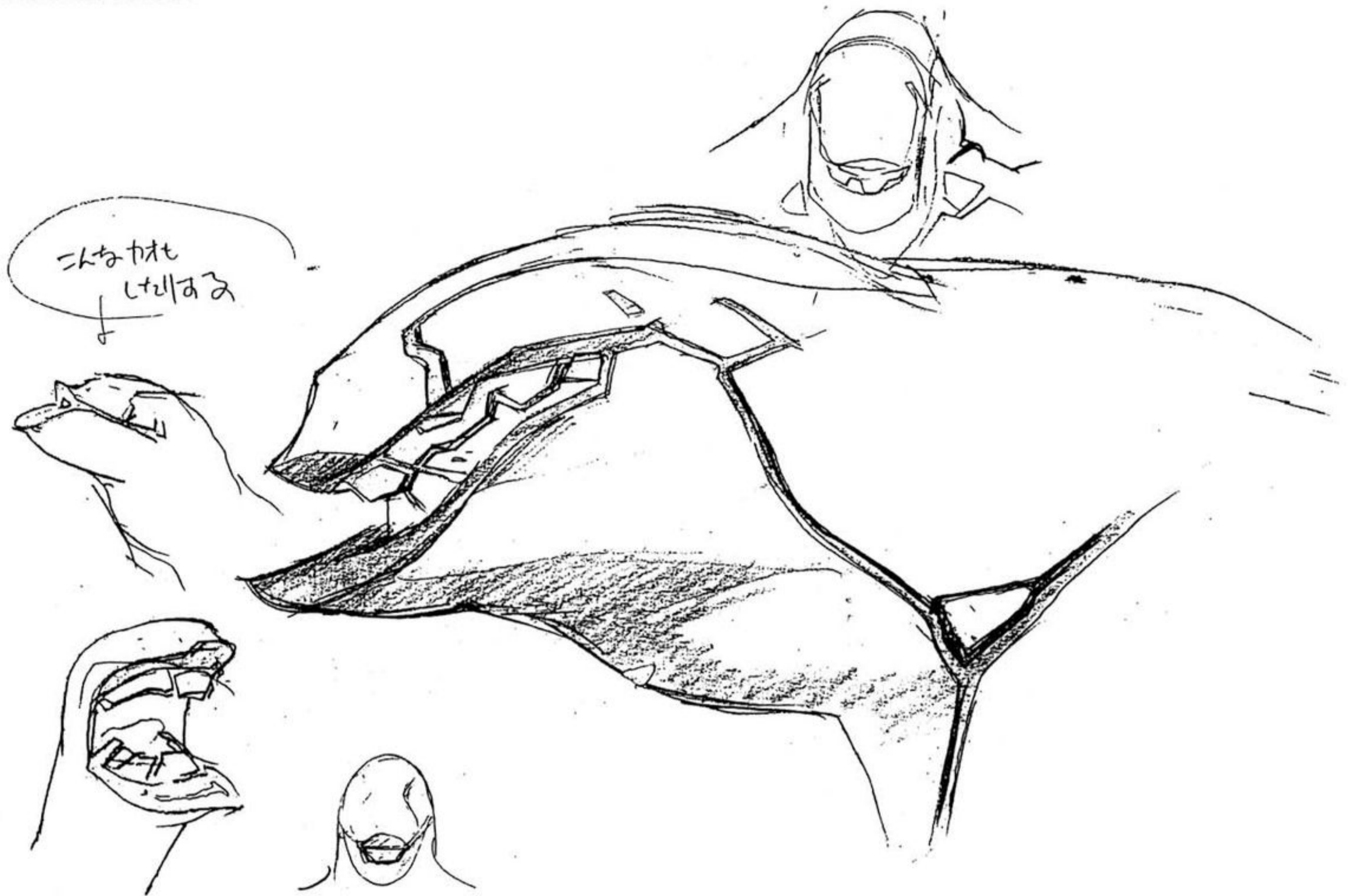

劇場版#25 設定資料

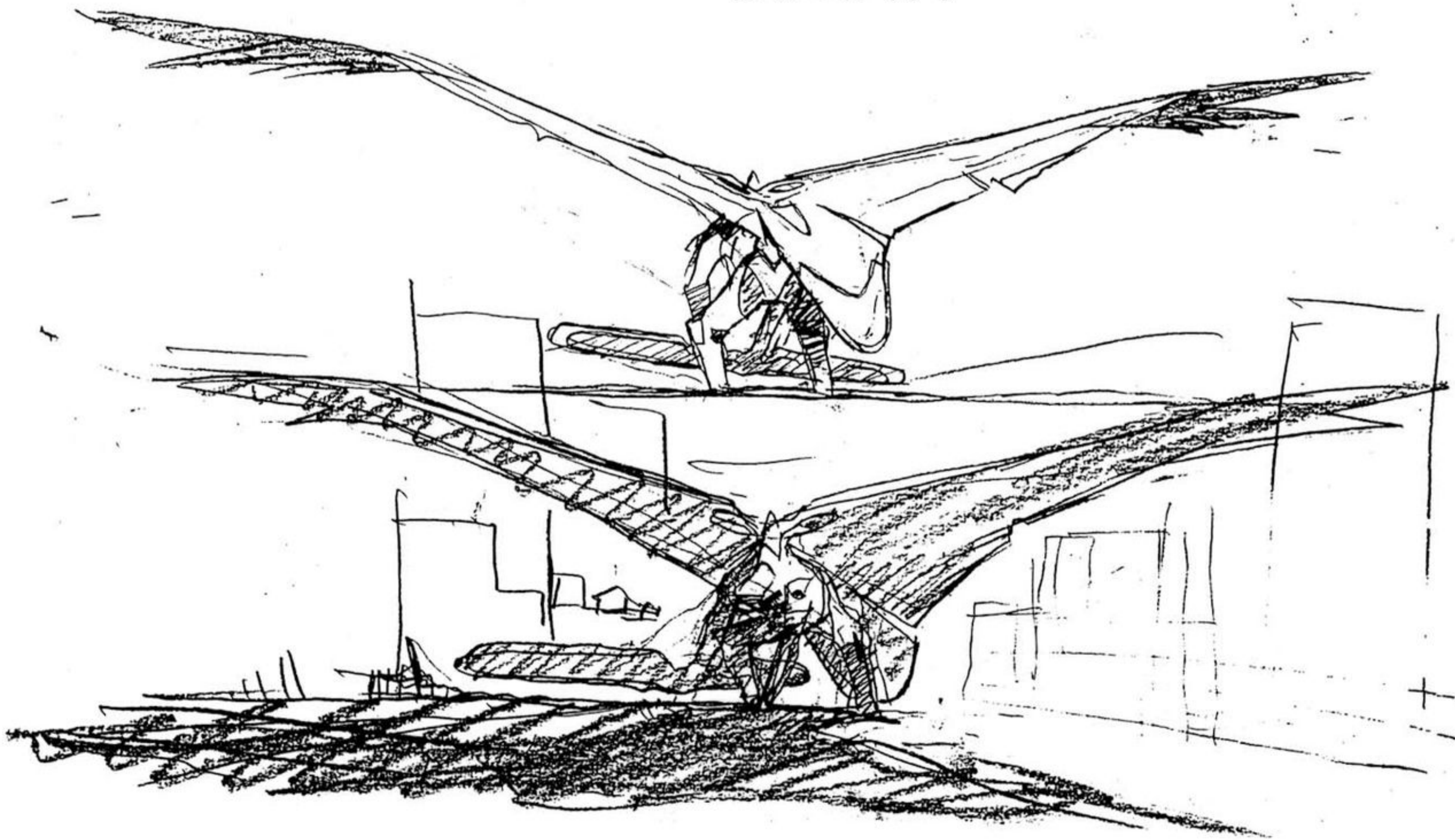

エナリアーランド

メタルマスターのキャラクター

メタルマスターのキャラクター

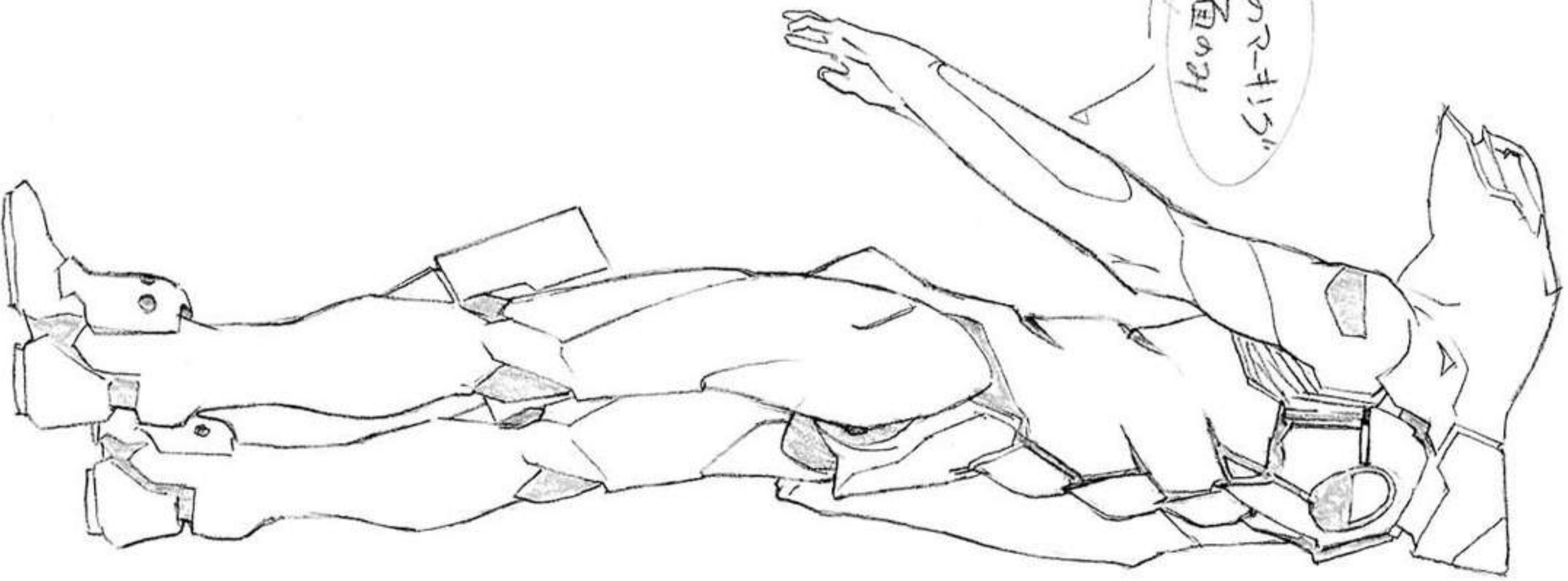
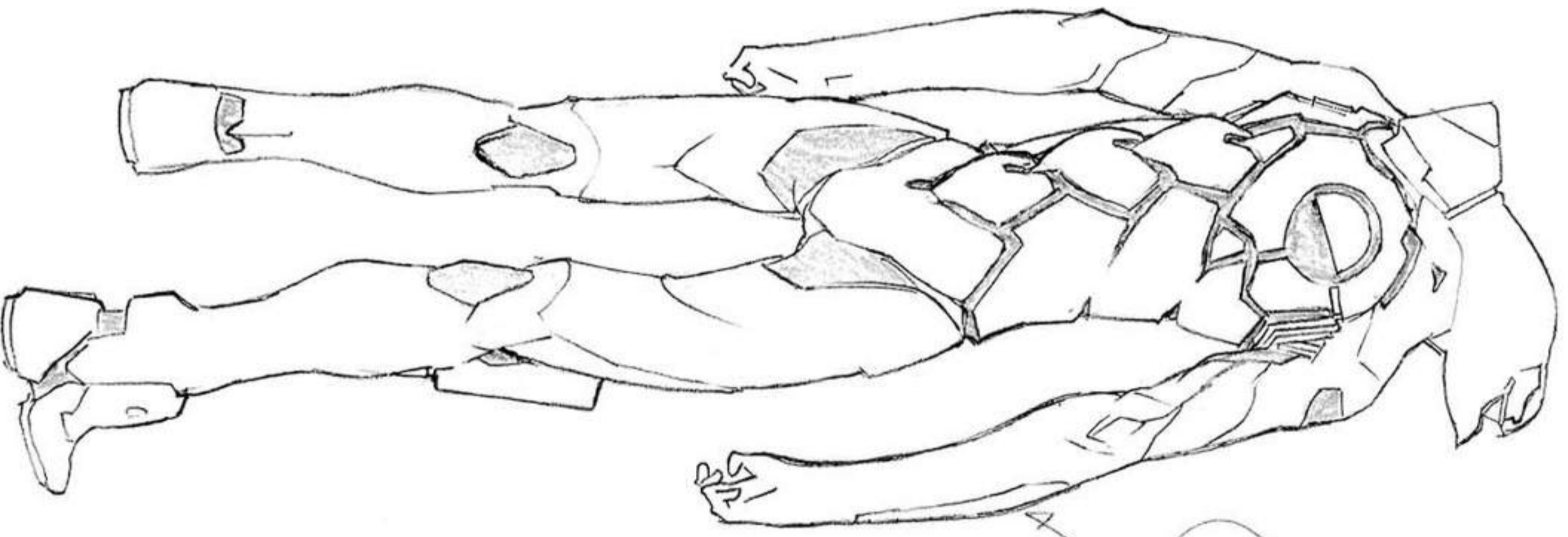
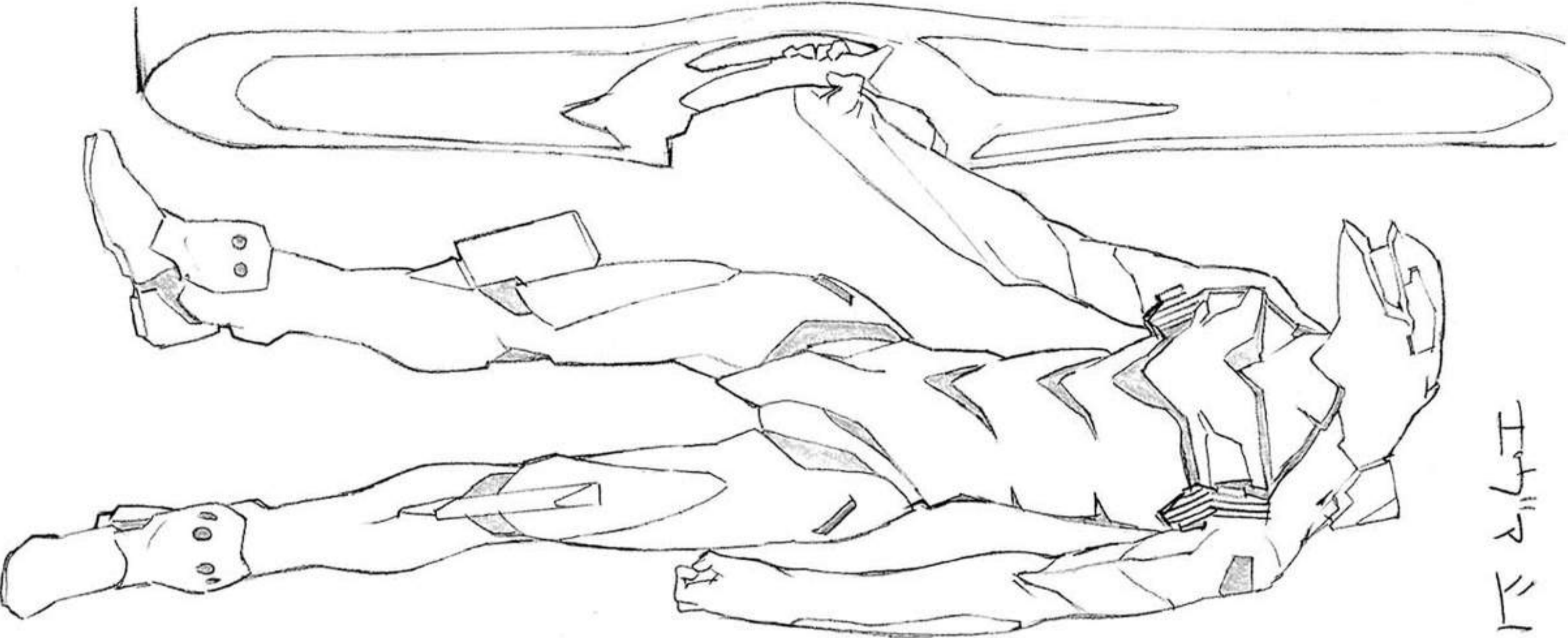

エヴァ シリーズ① ラ7

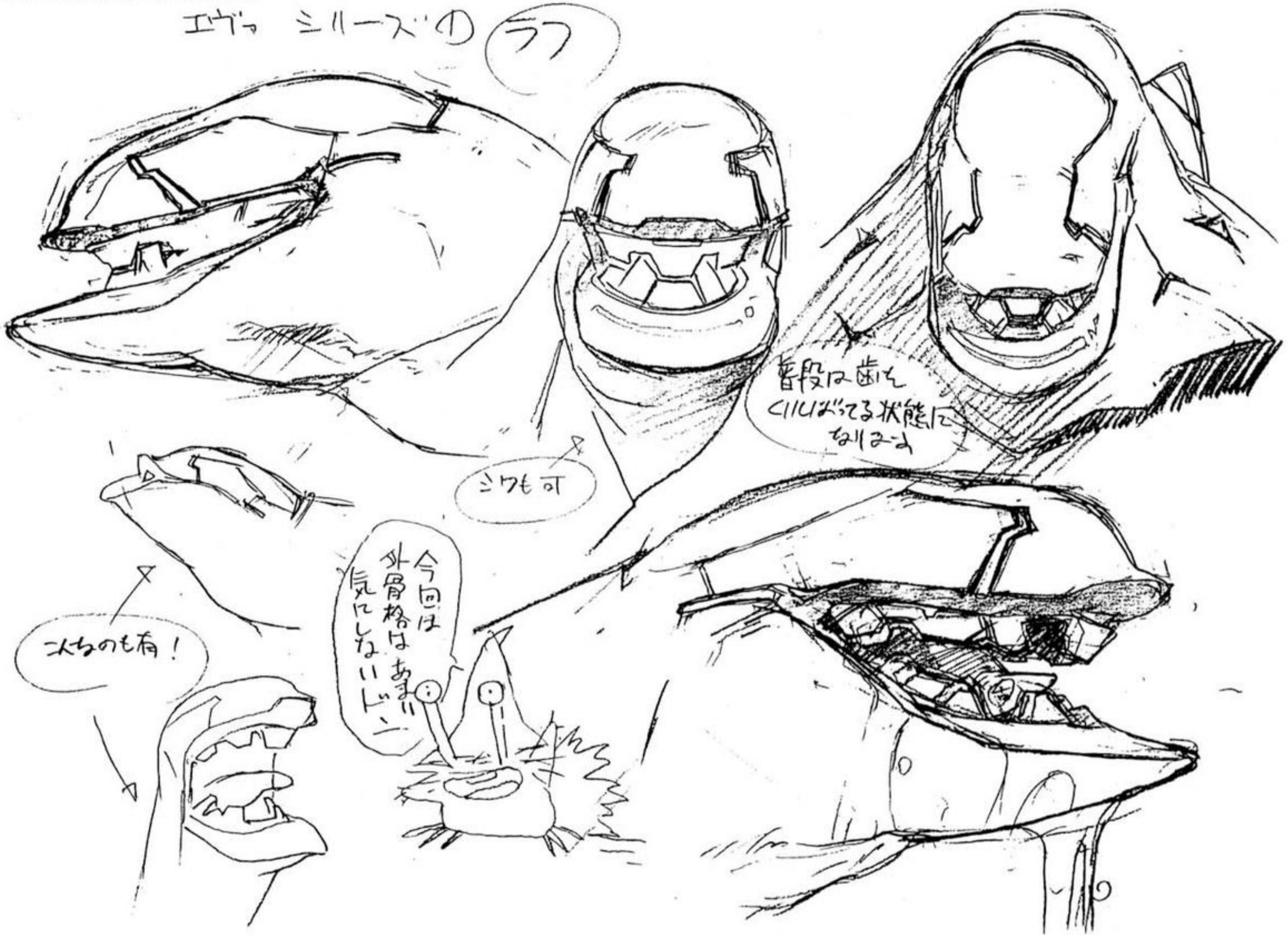

エヴァ シリーズ②



エヴァ 42 (3)

77

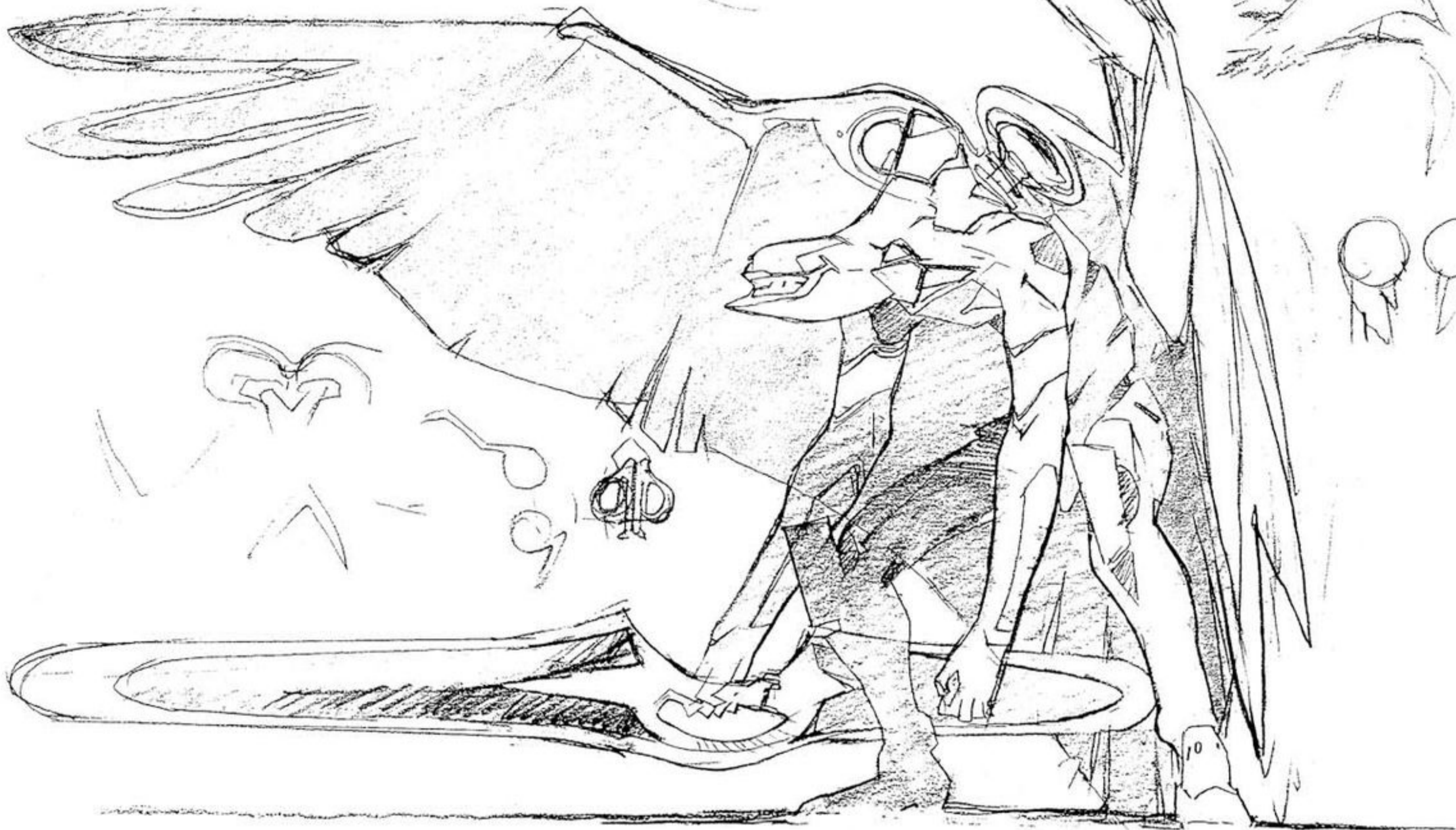

昔の12-14が
 世に出た
 後、X2E2. 翼に
 なる

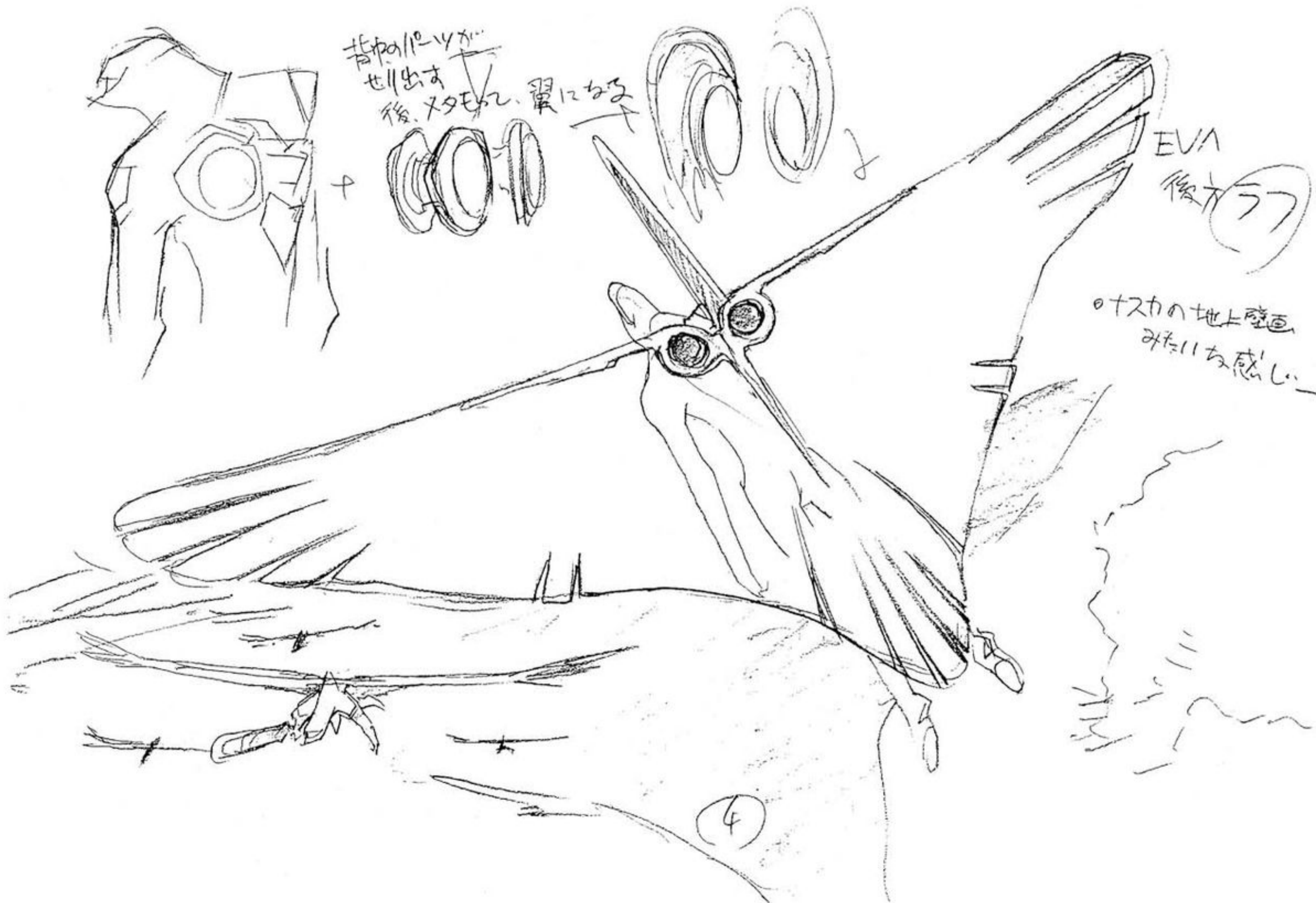

EVA
 後 77

0+2力の地上壁面
 みたに感じし

4

背中のパーツが割れて
翼の動き

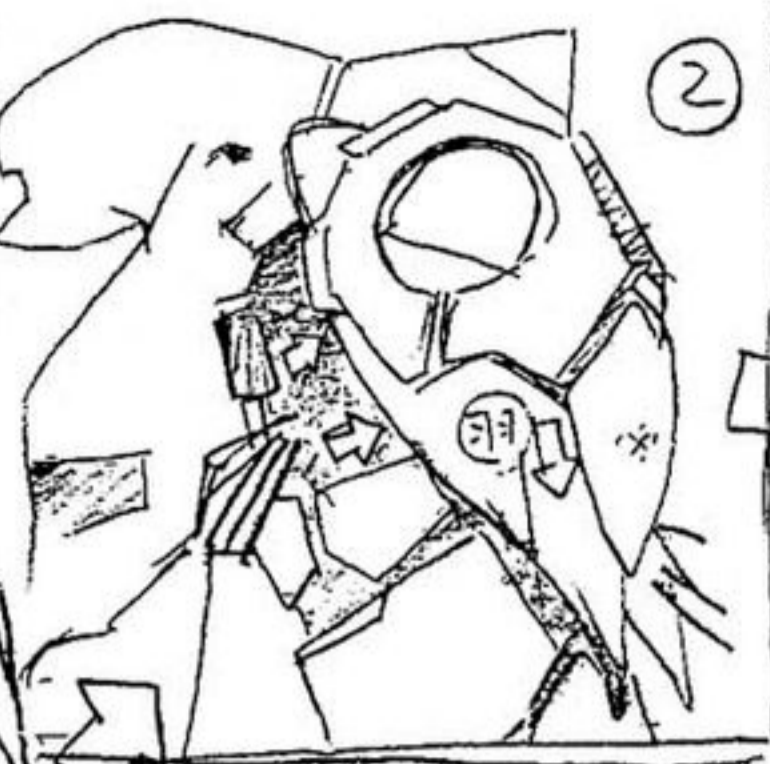
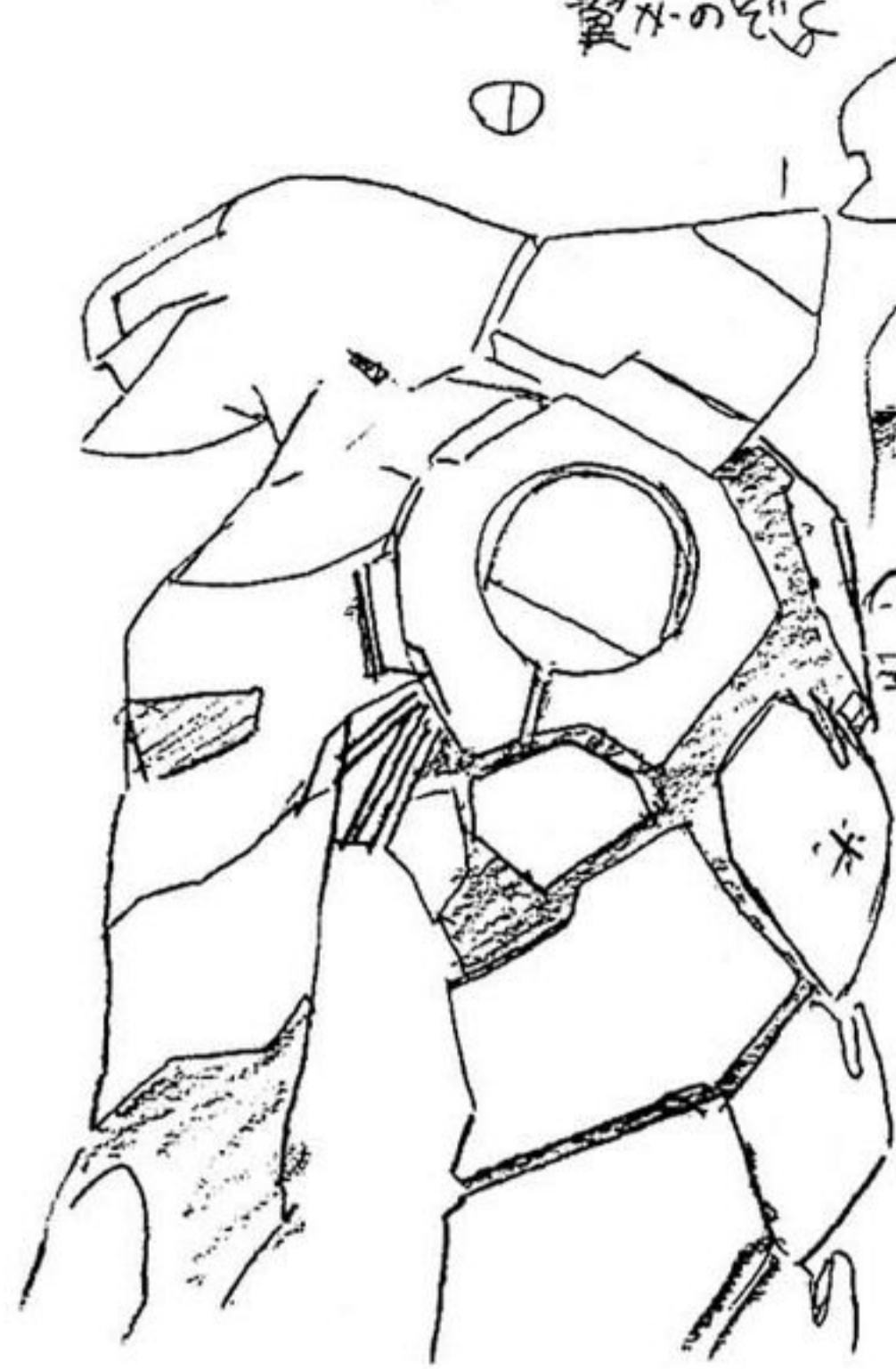

いかにたいこは
ブレてしまおう!



背中の1214の細い部分
テクトーに変型させたい

翼の広げ方 参考
(逆さから)



1/10Aの割合でさける?
200x150%
132%

EVA#25 戦場の仕様
標準装備。

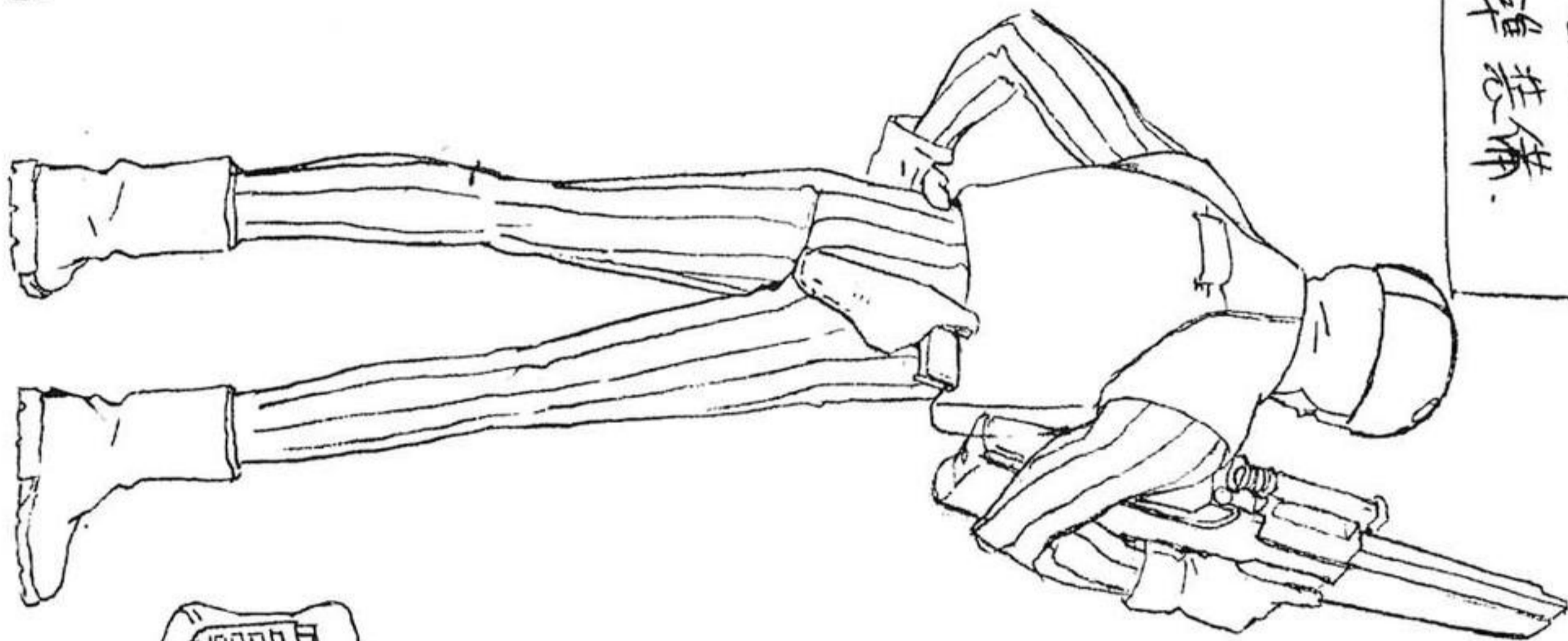
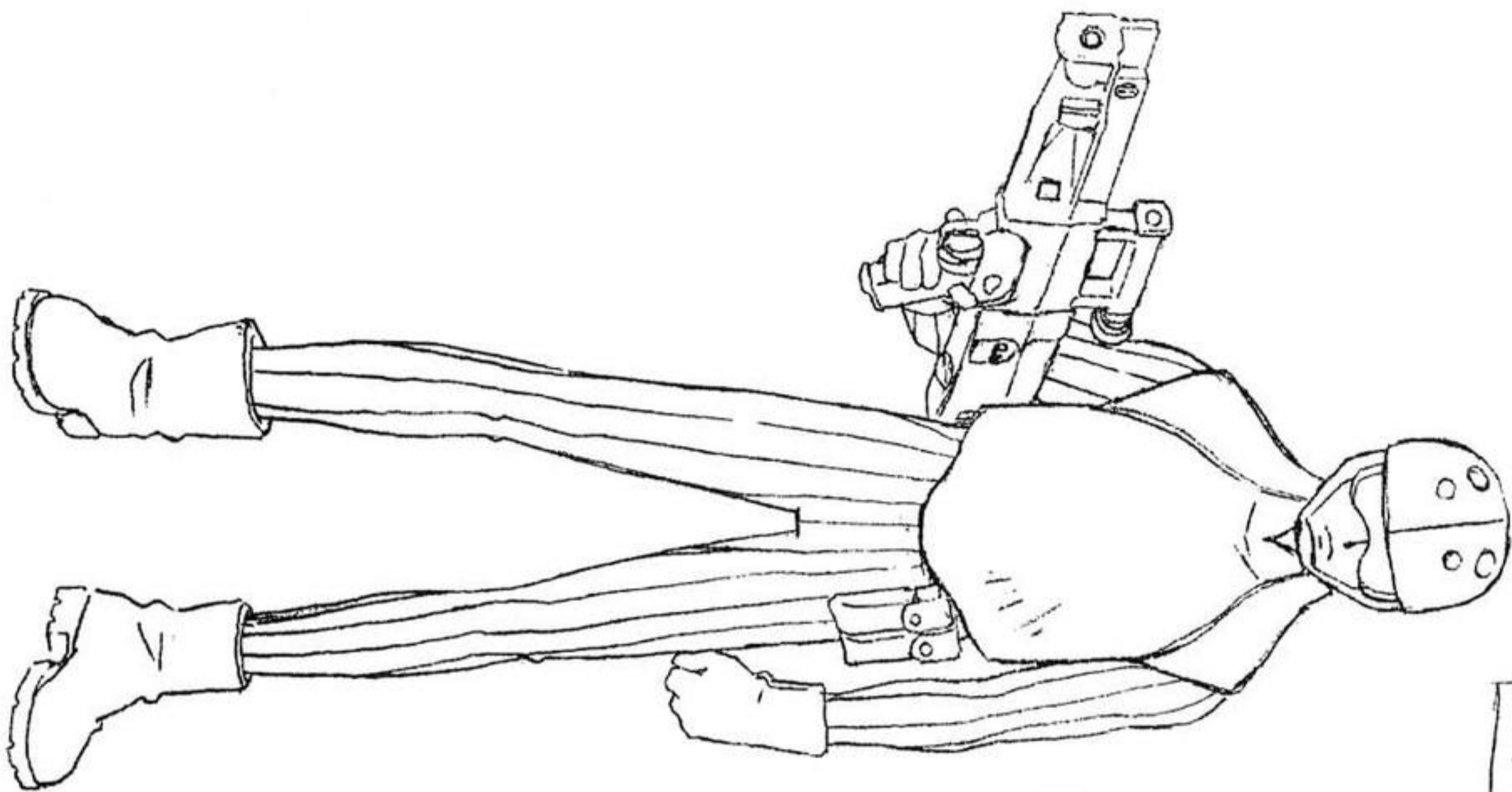

T-2UR20
P414-5472L

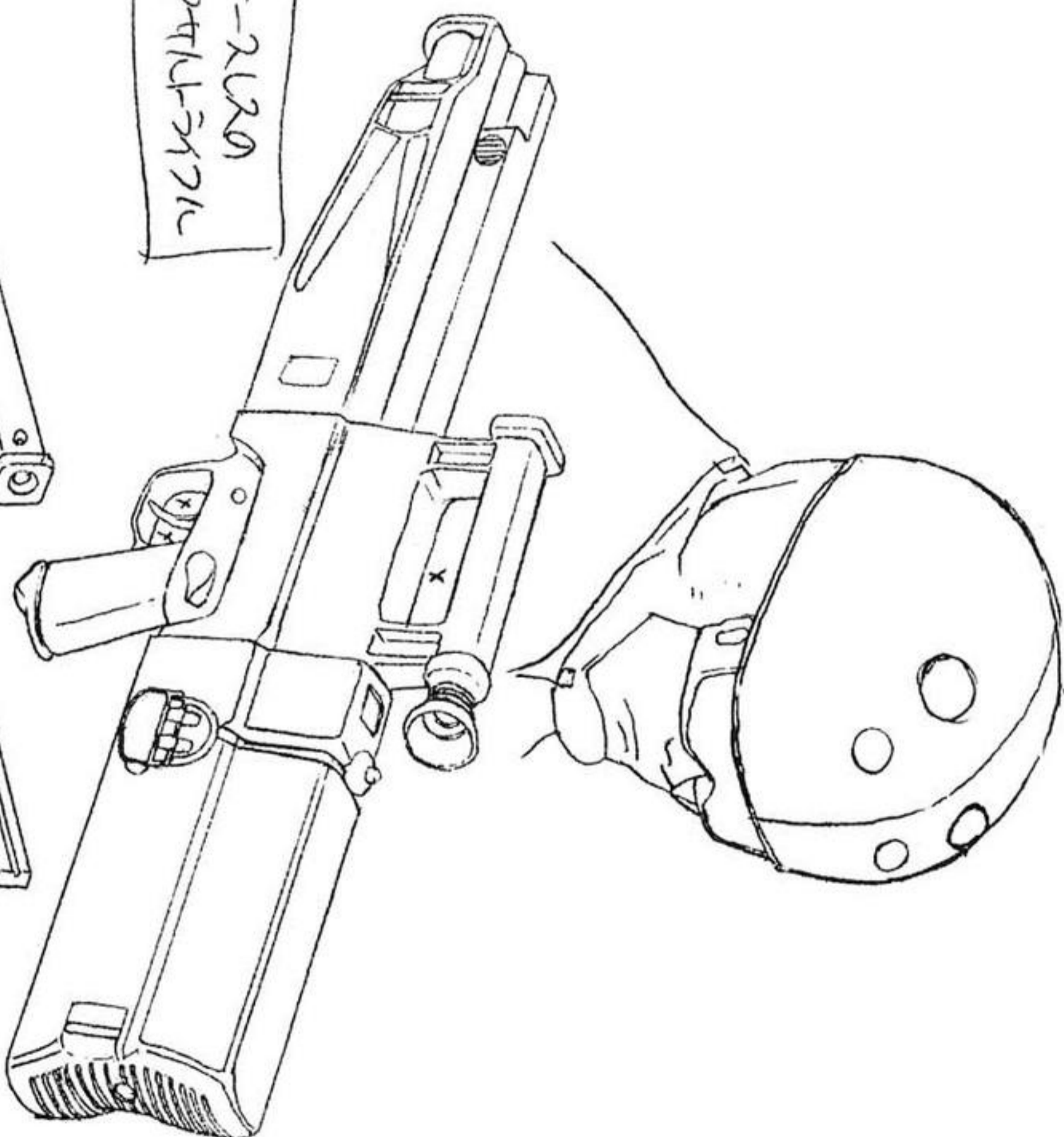
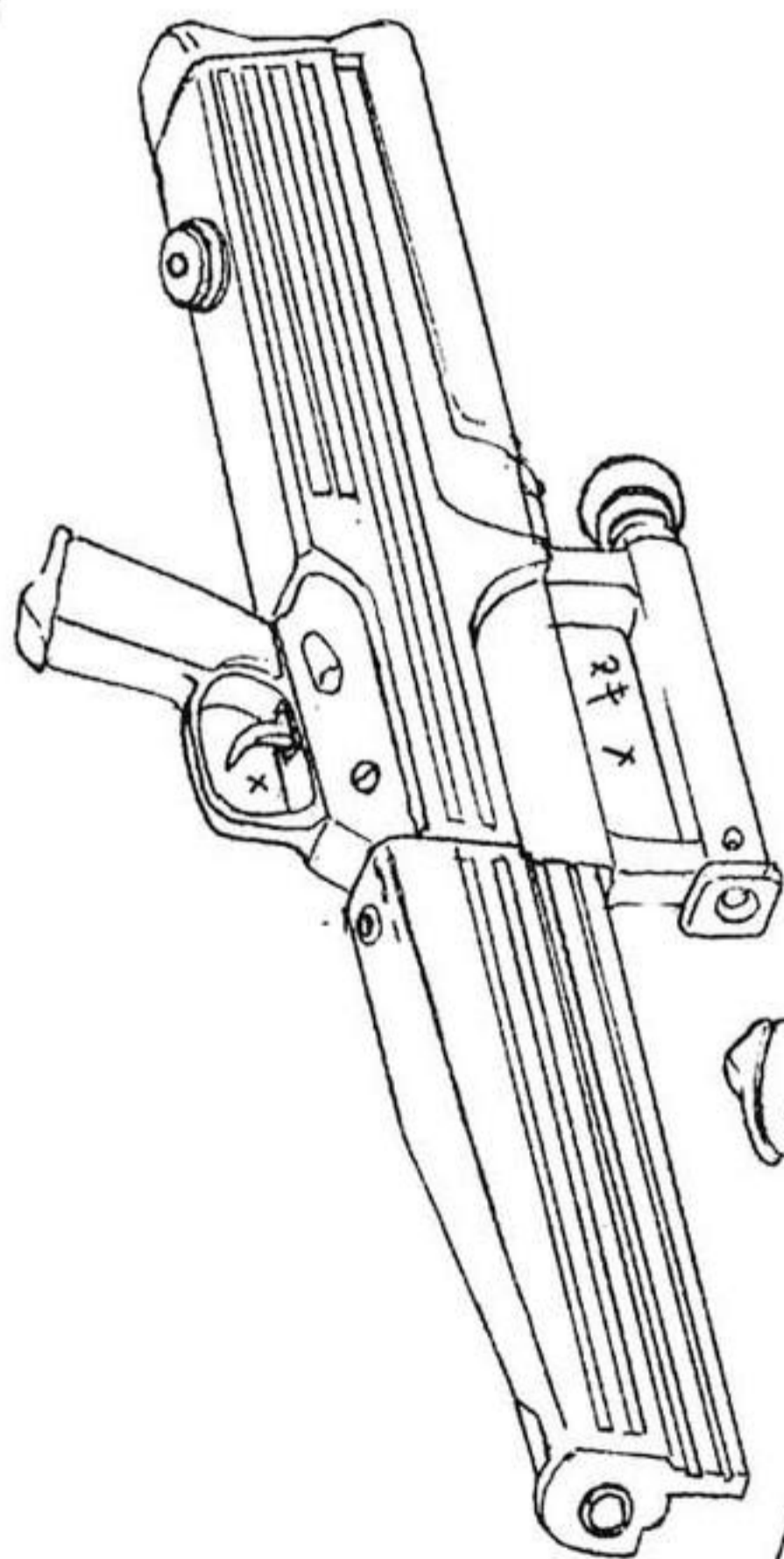

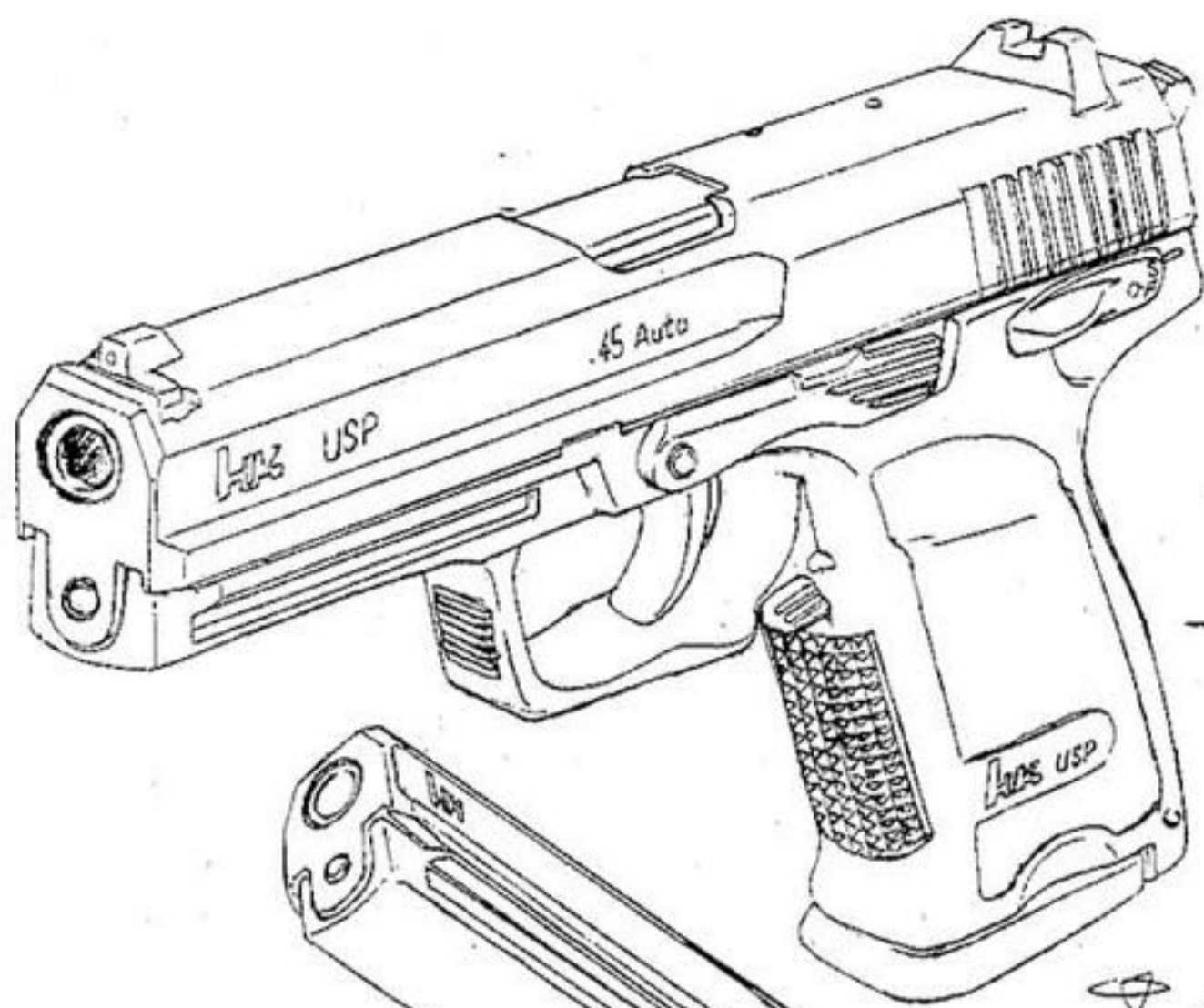

ミサトの手がけ
銃少し大目27

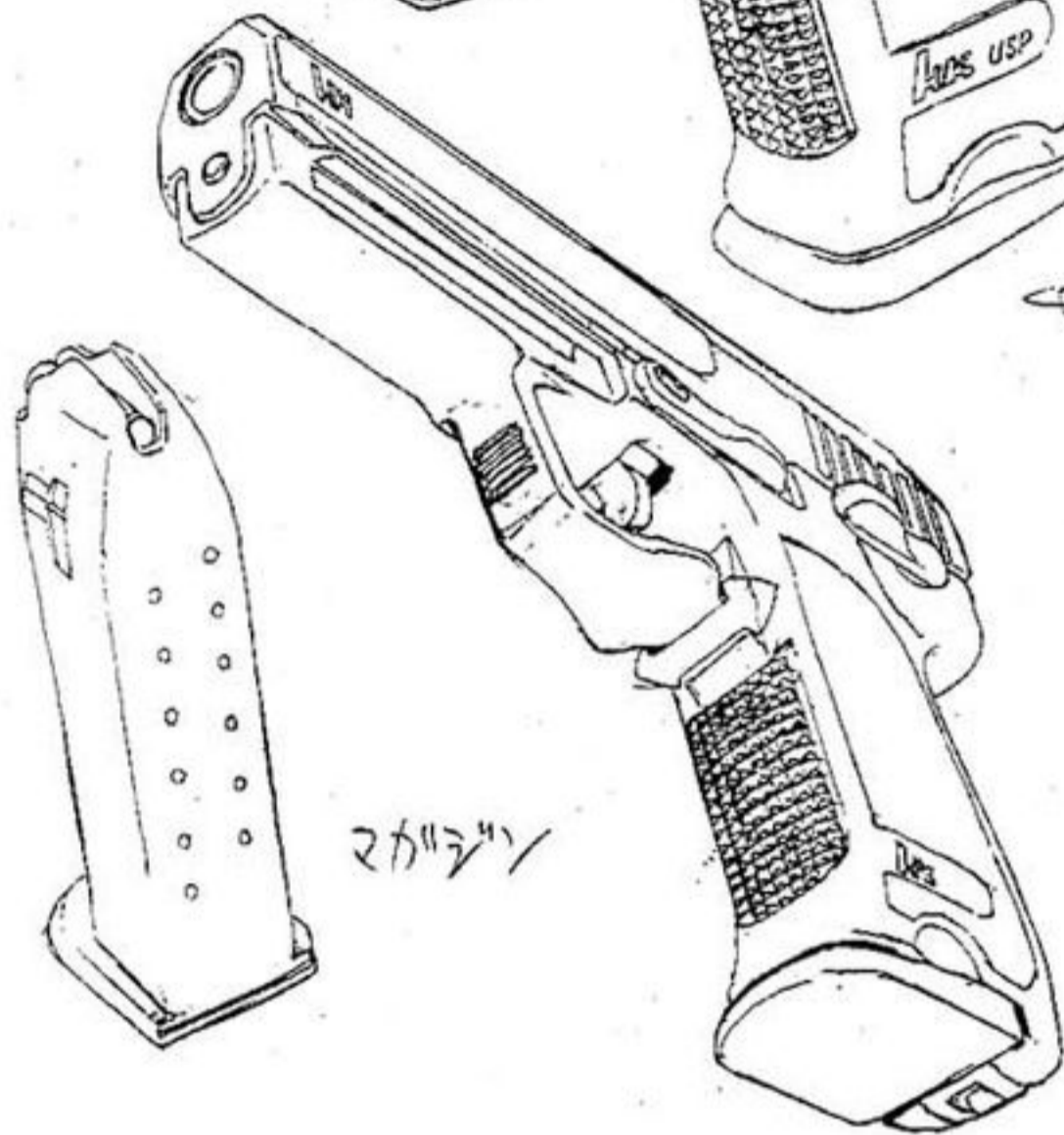

マガジン

細かい文字
デテール等は
作画時省略に
下す



ミサトの銃

H&K USP



ネロ側ハンドガン

17クロック17



細かい文字、デテール等は
作画時省略に下す



挿鉄



ミサトの銃

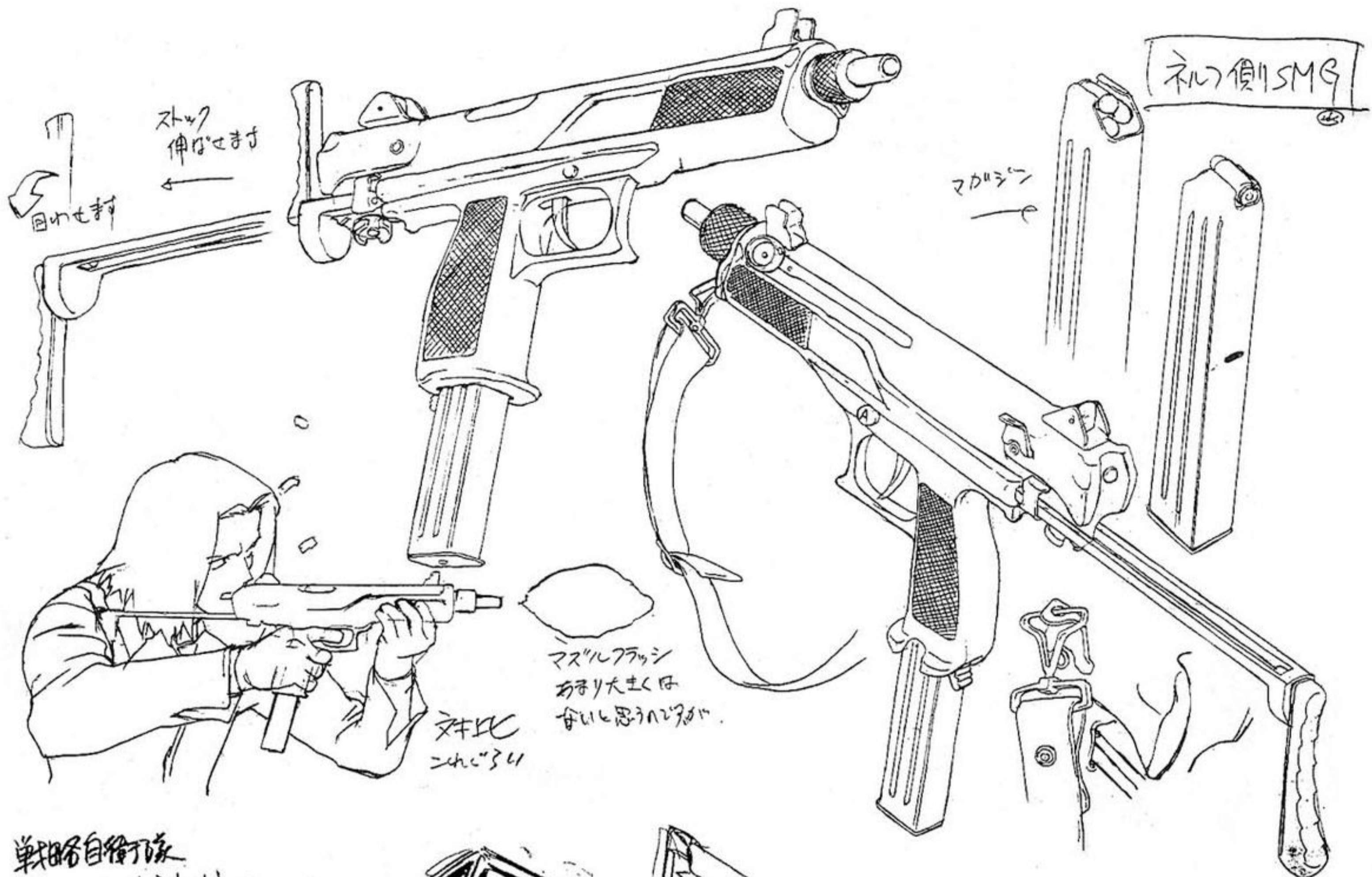

単独自衛隊
軽戦術車(VTOL) 37.

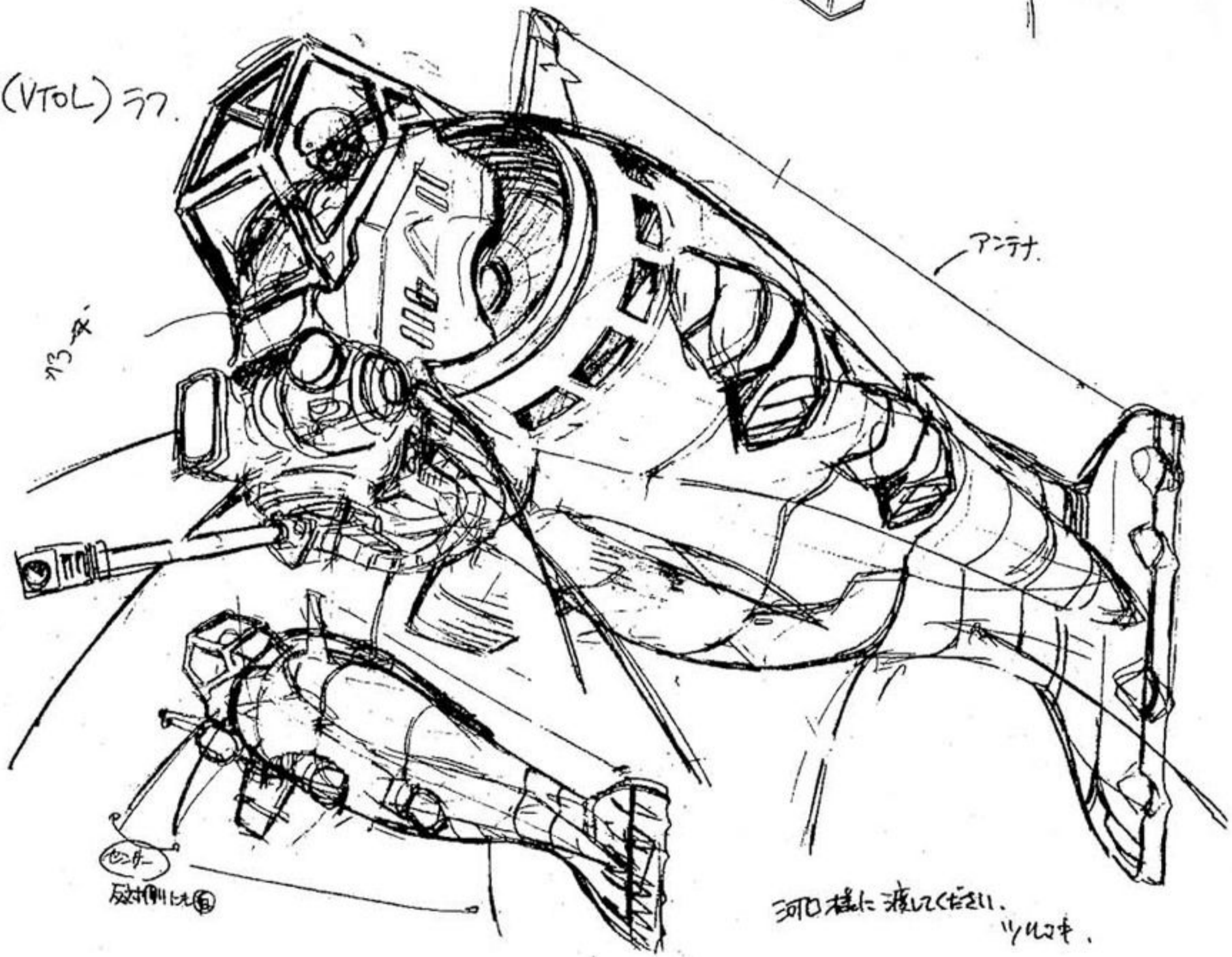

#25 C-141
ネロ警備車

決定稿

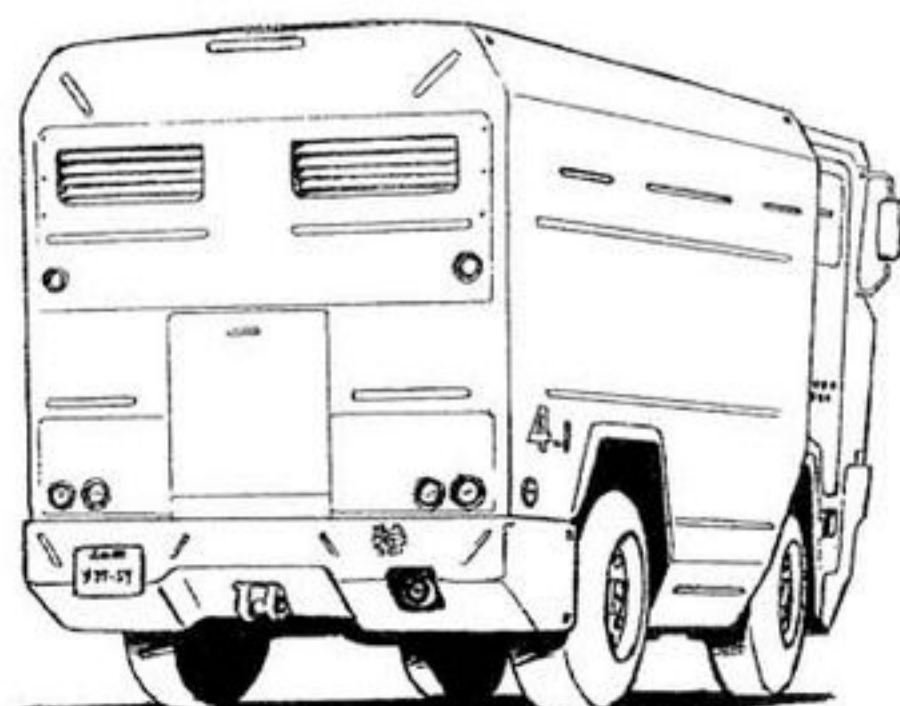
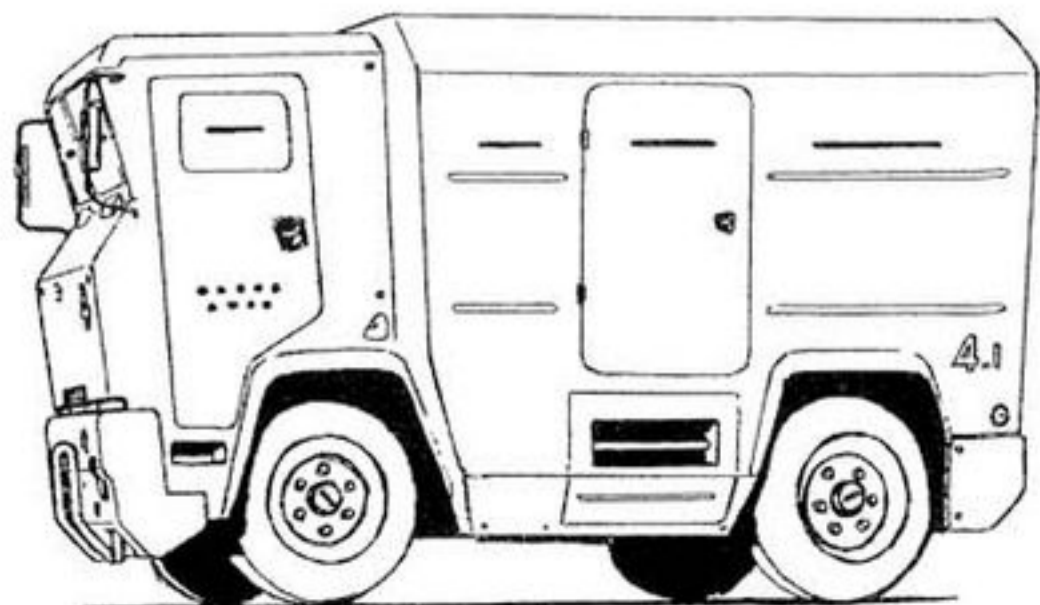

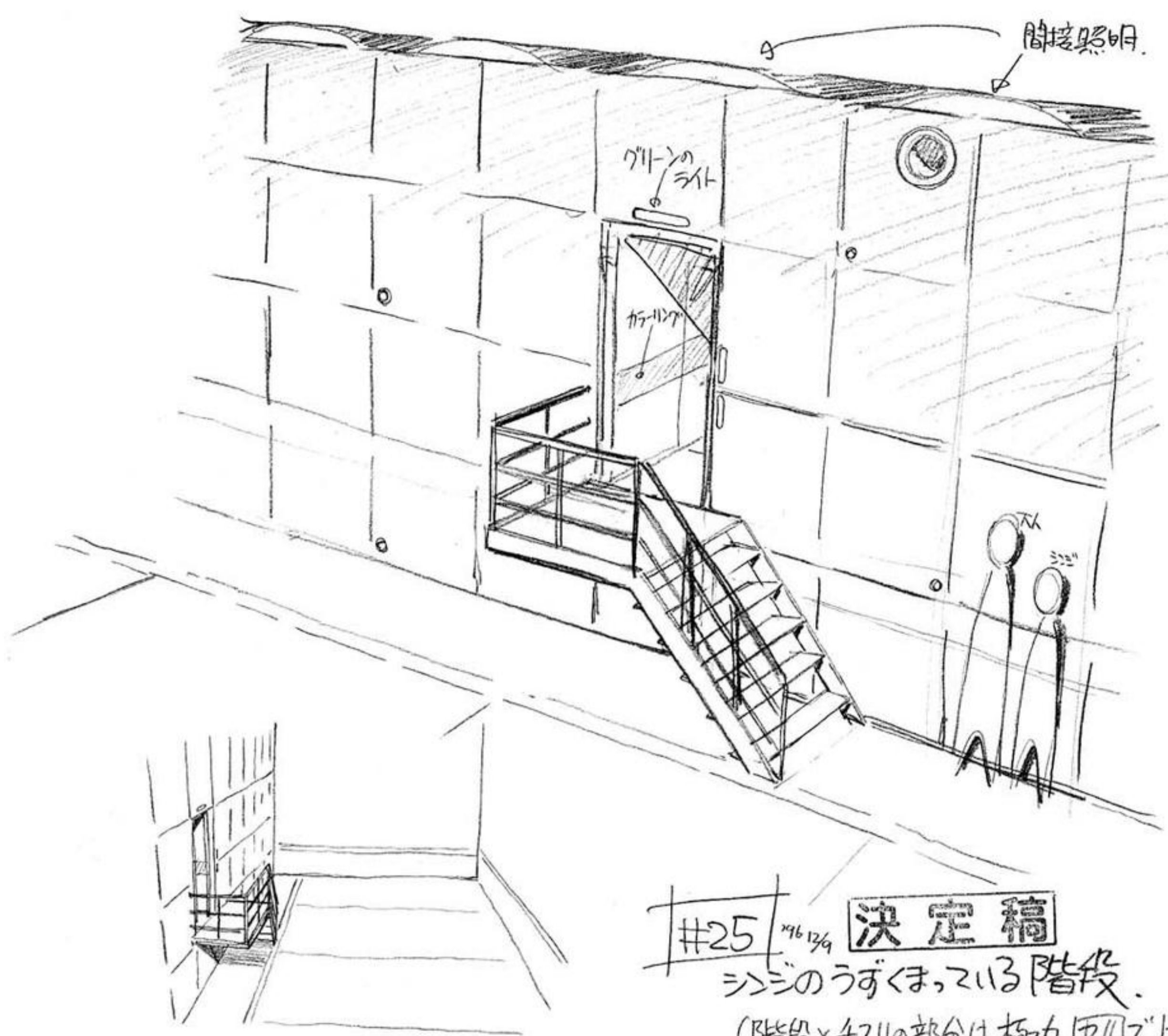

#25 ^{1961/4} **決定稿**
 シンジのうすくまっている階段。
 (階段と軒りの部分は極力「色」でよく)

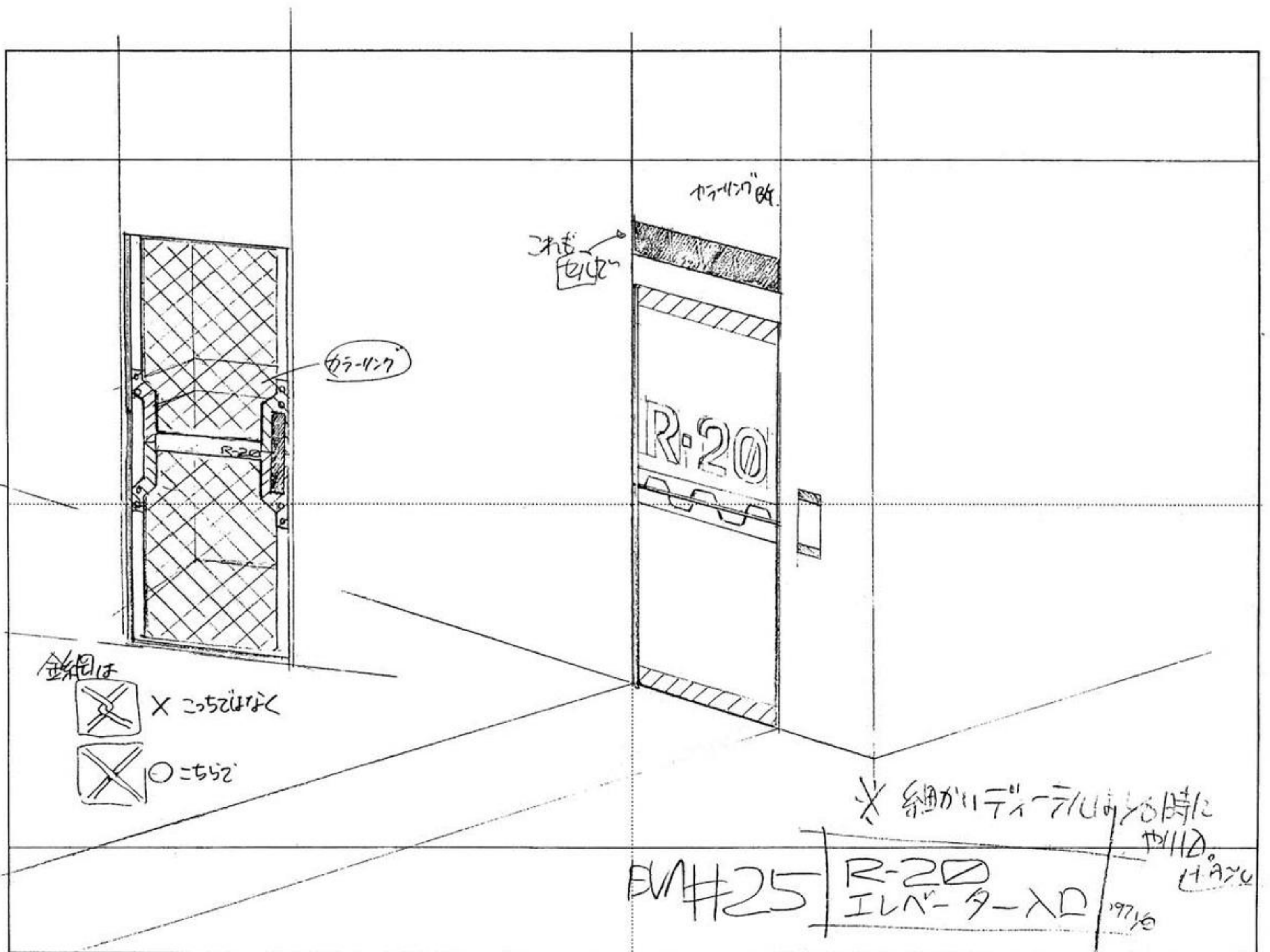

新#25 式号机 参考

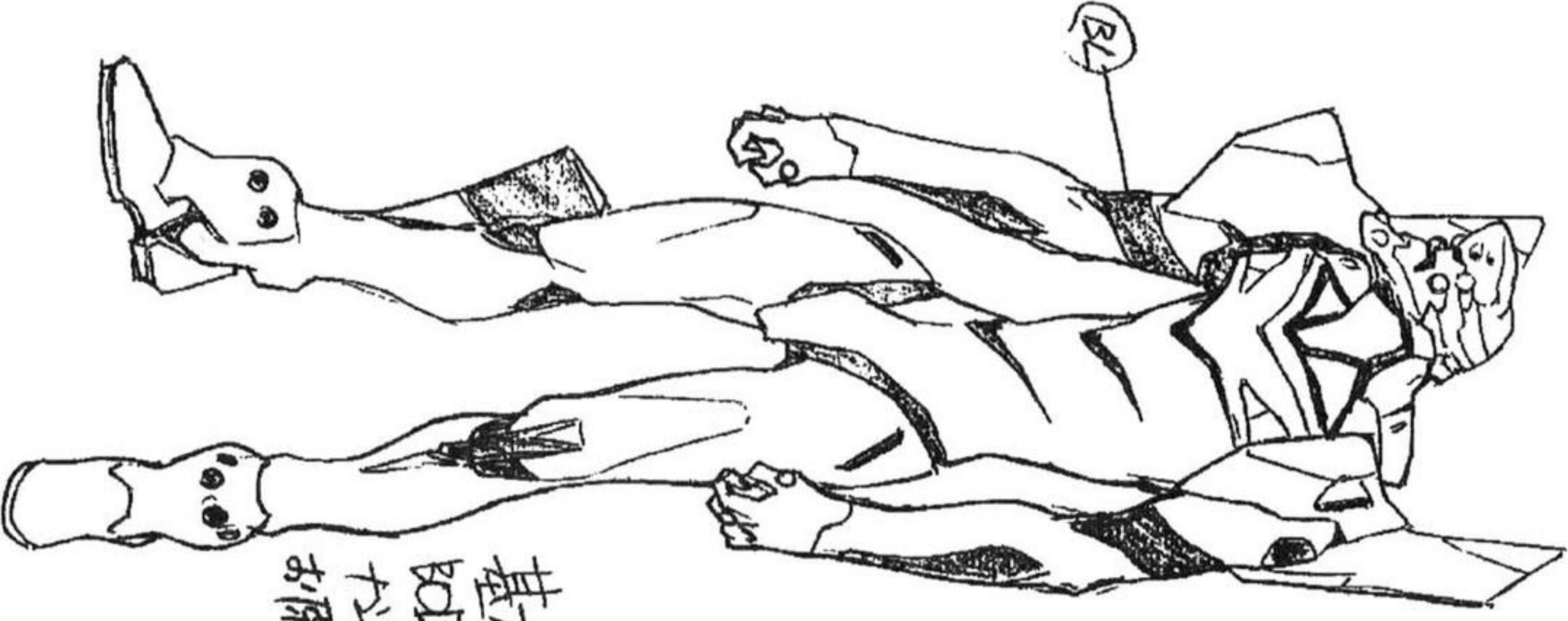

基本の形
BODYの形
は、
おそろい

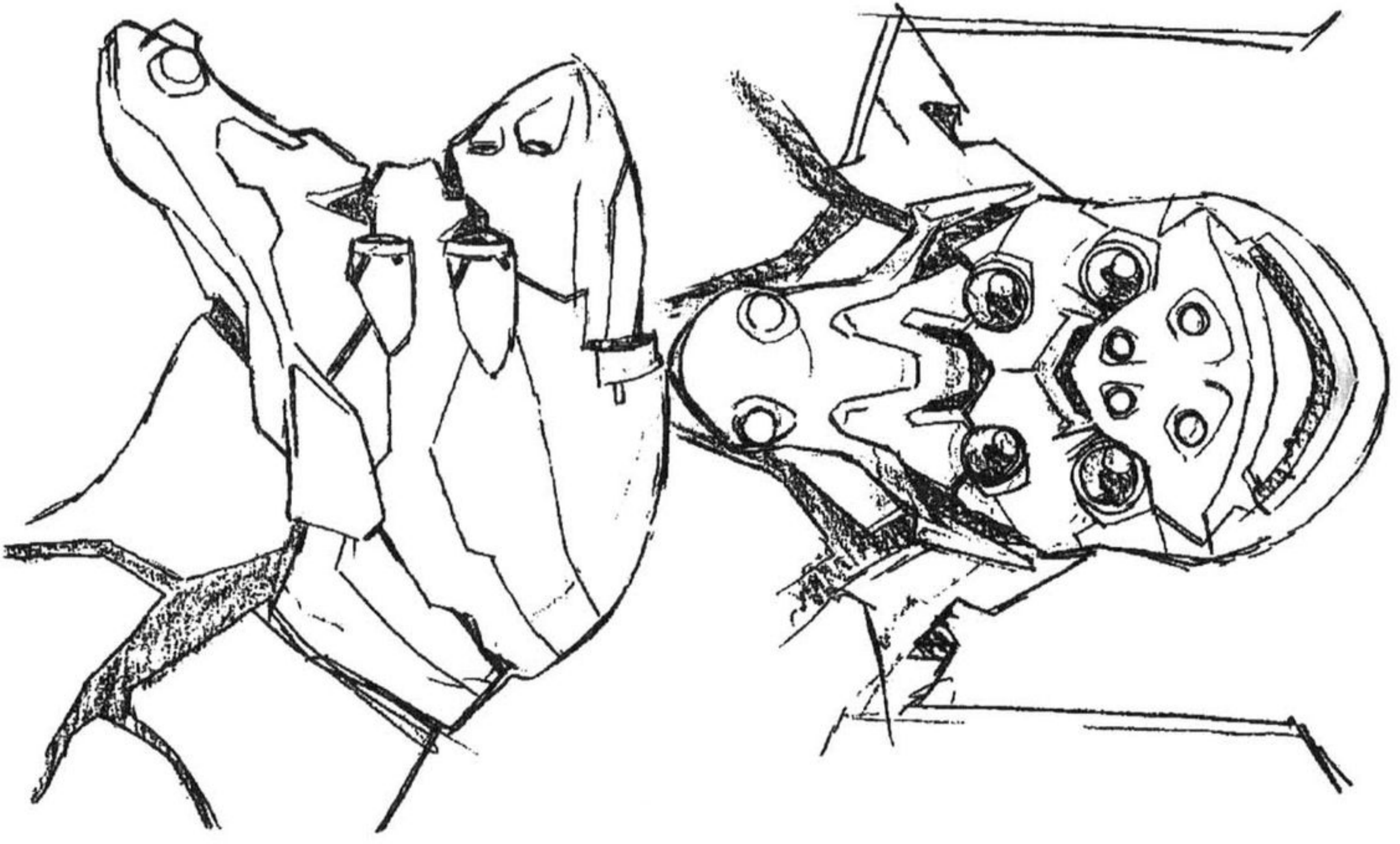
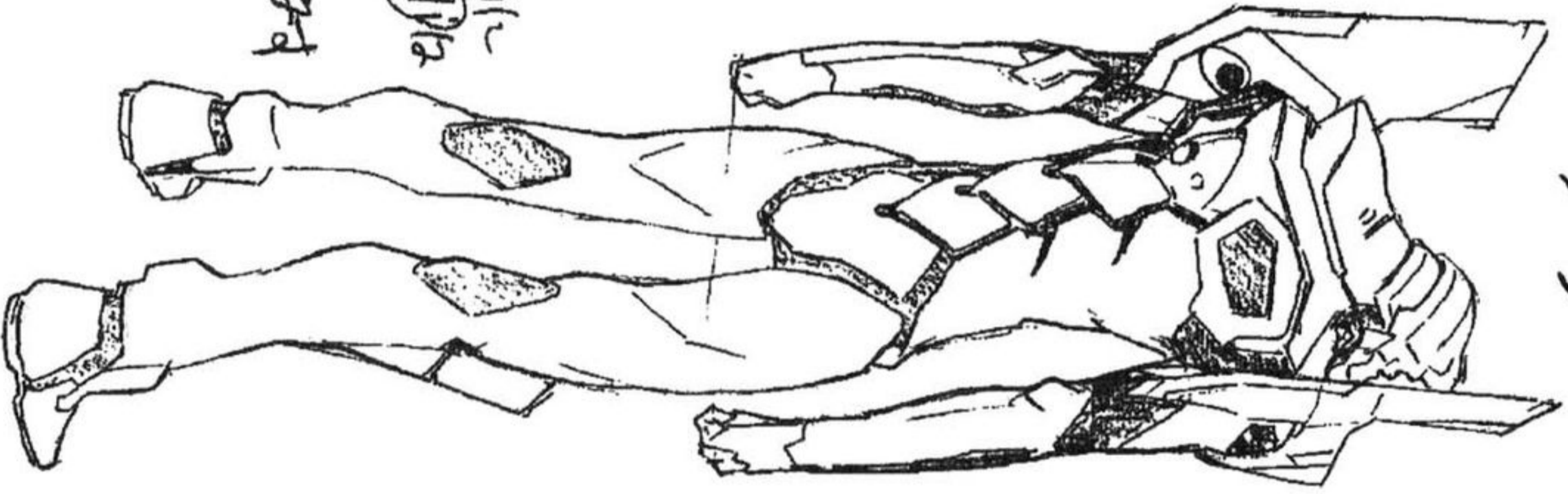

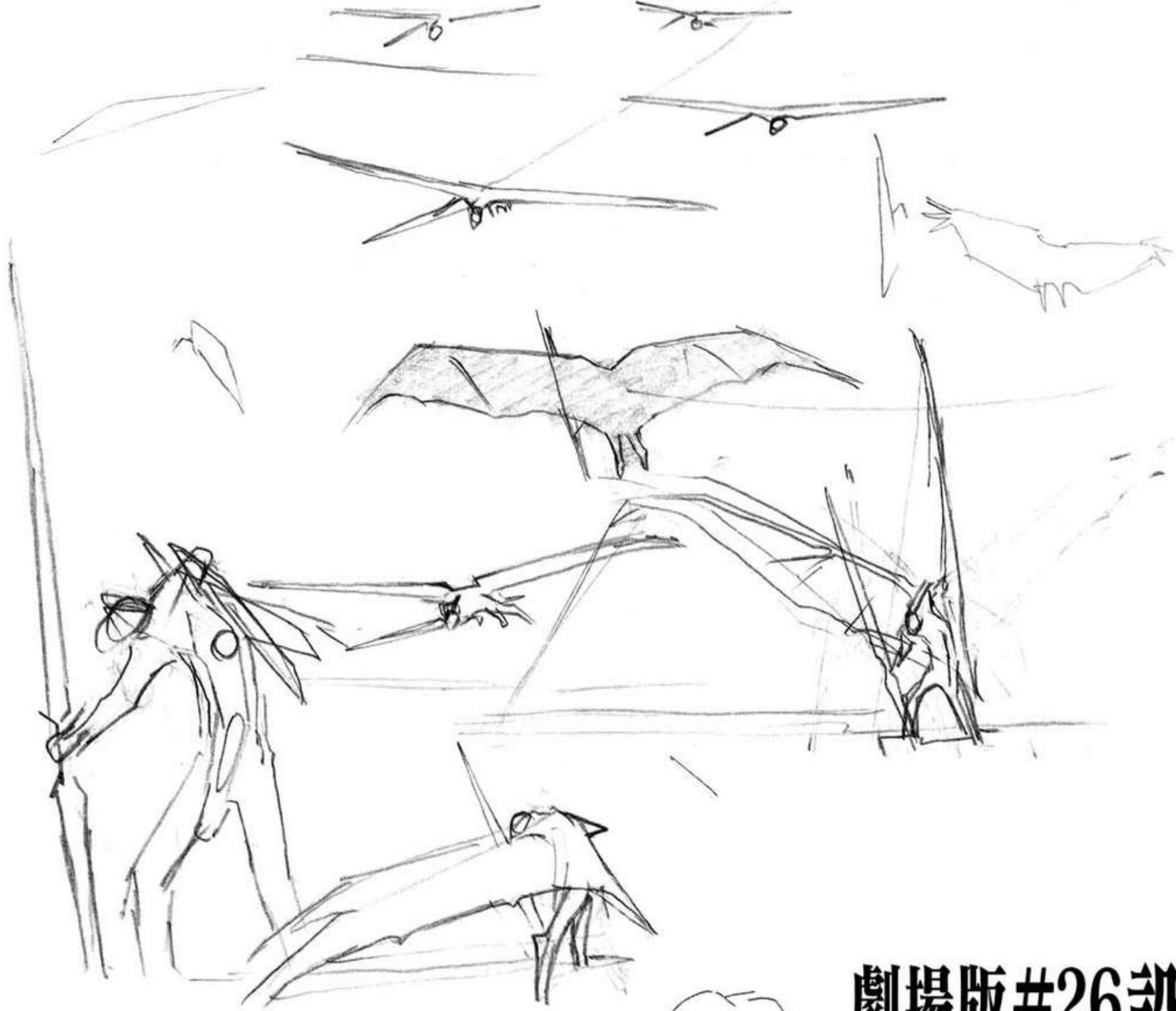

劇場版#26 設定資料

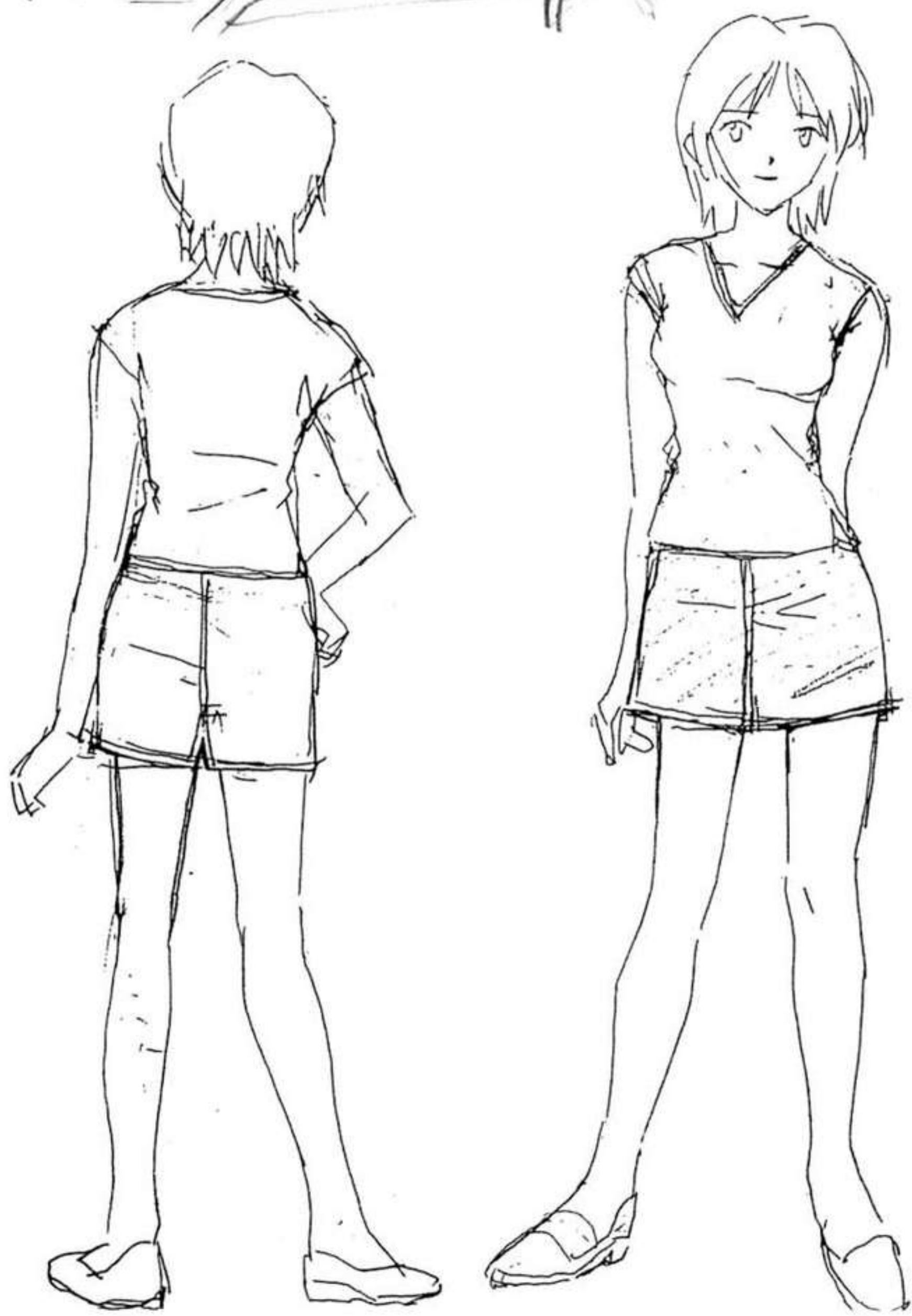

〔唯〕

新#26
C-457.

C-136~195

シンジの服
参考です!

ちびやん
等身もこんな感じ



白
赤
ニニから紐
さじにみ
4cm
■ 正方形
ビニール
パンツはなしです

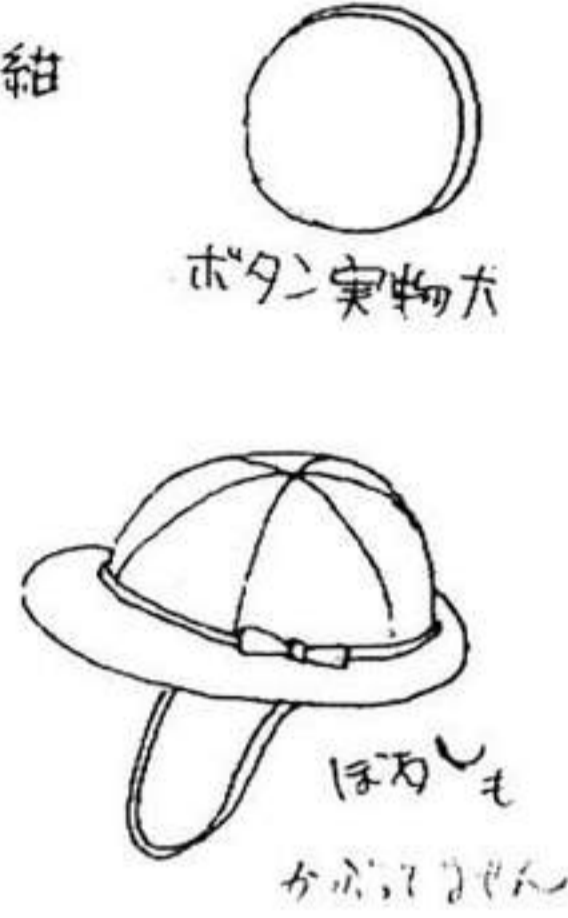

ボタン実物大

ほろも
かぶるかん

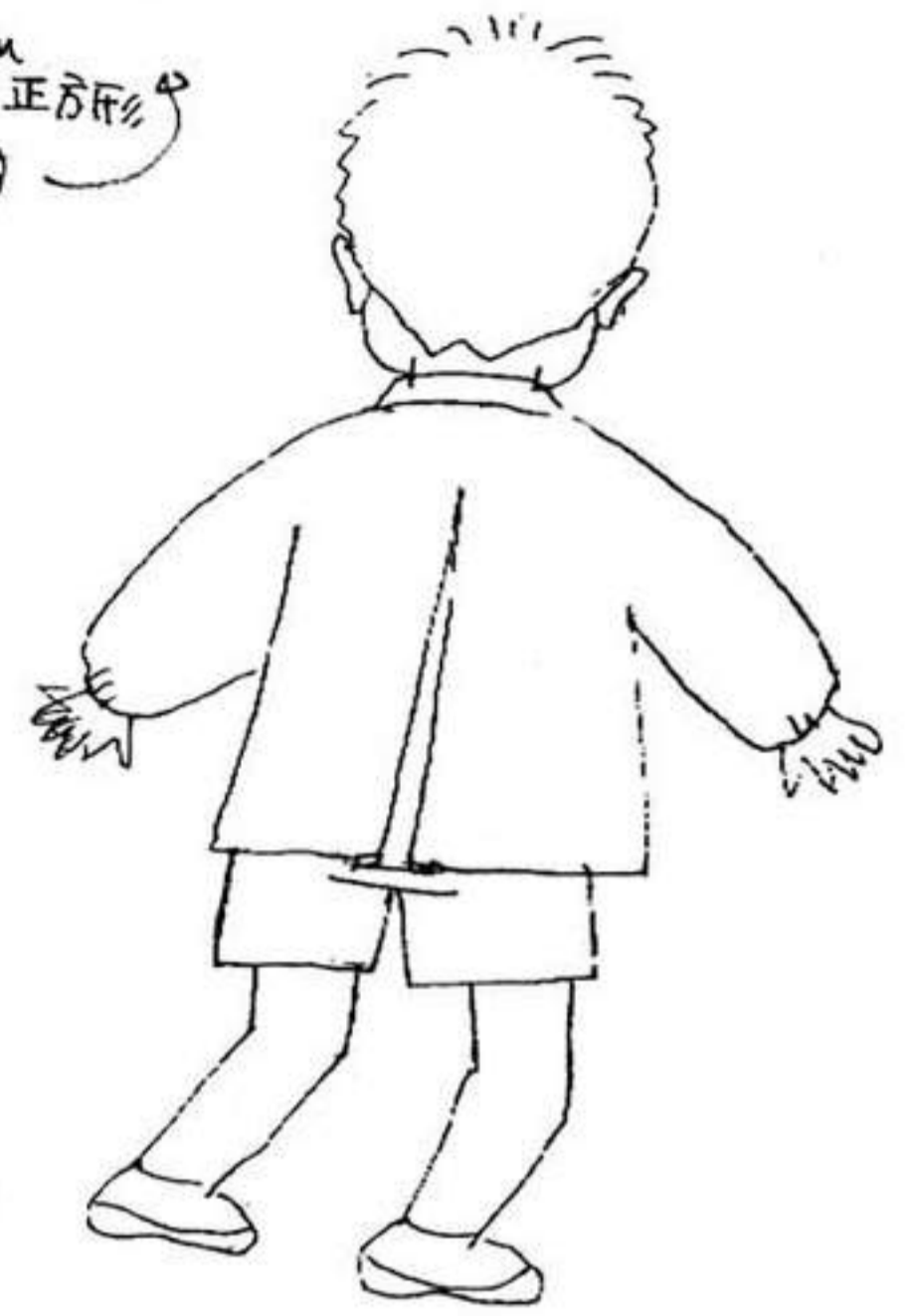

7/7も
なし

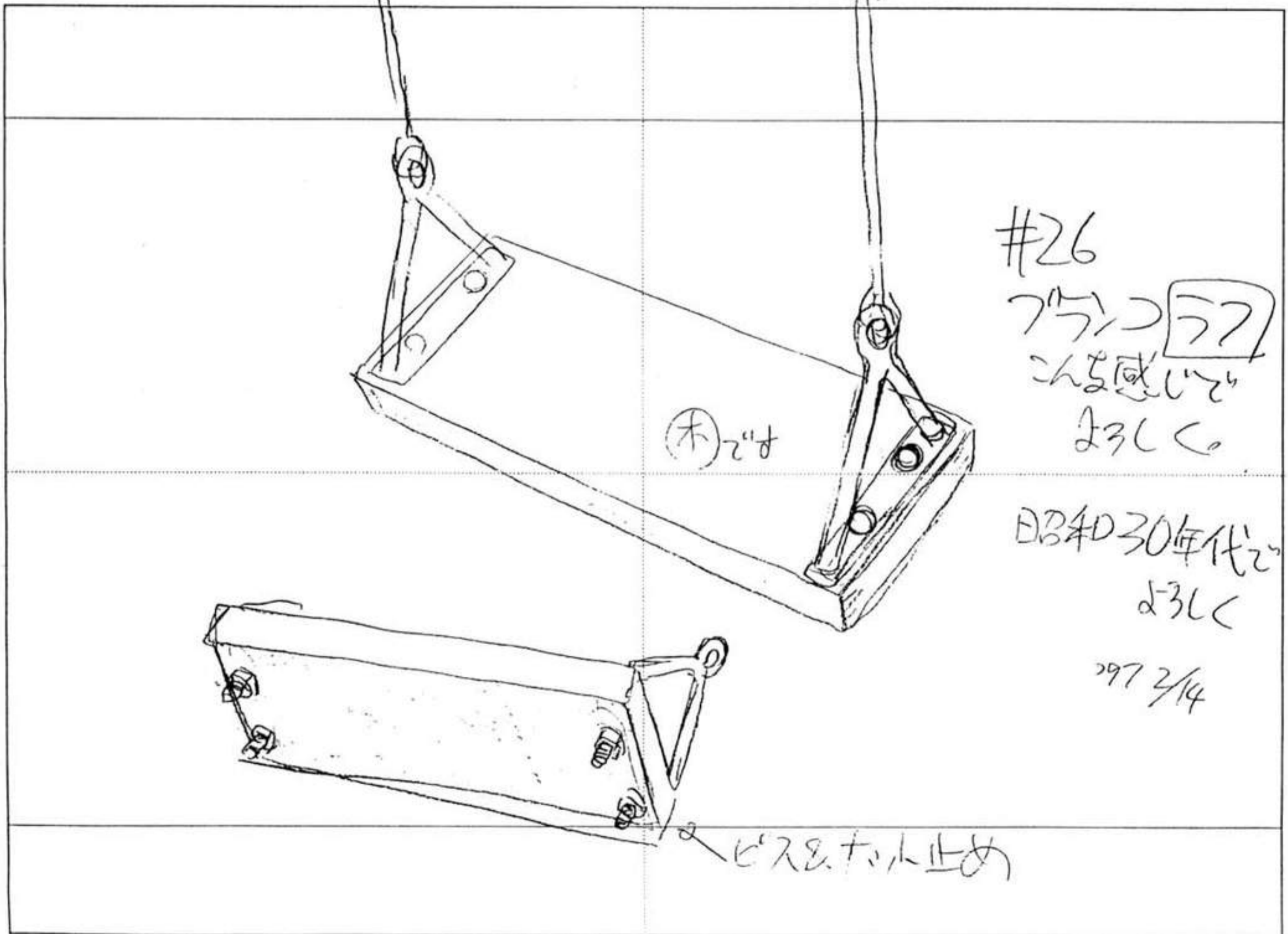
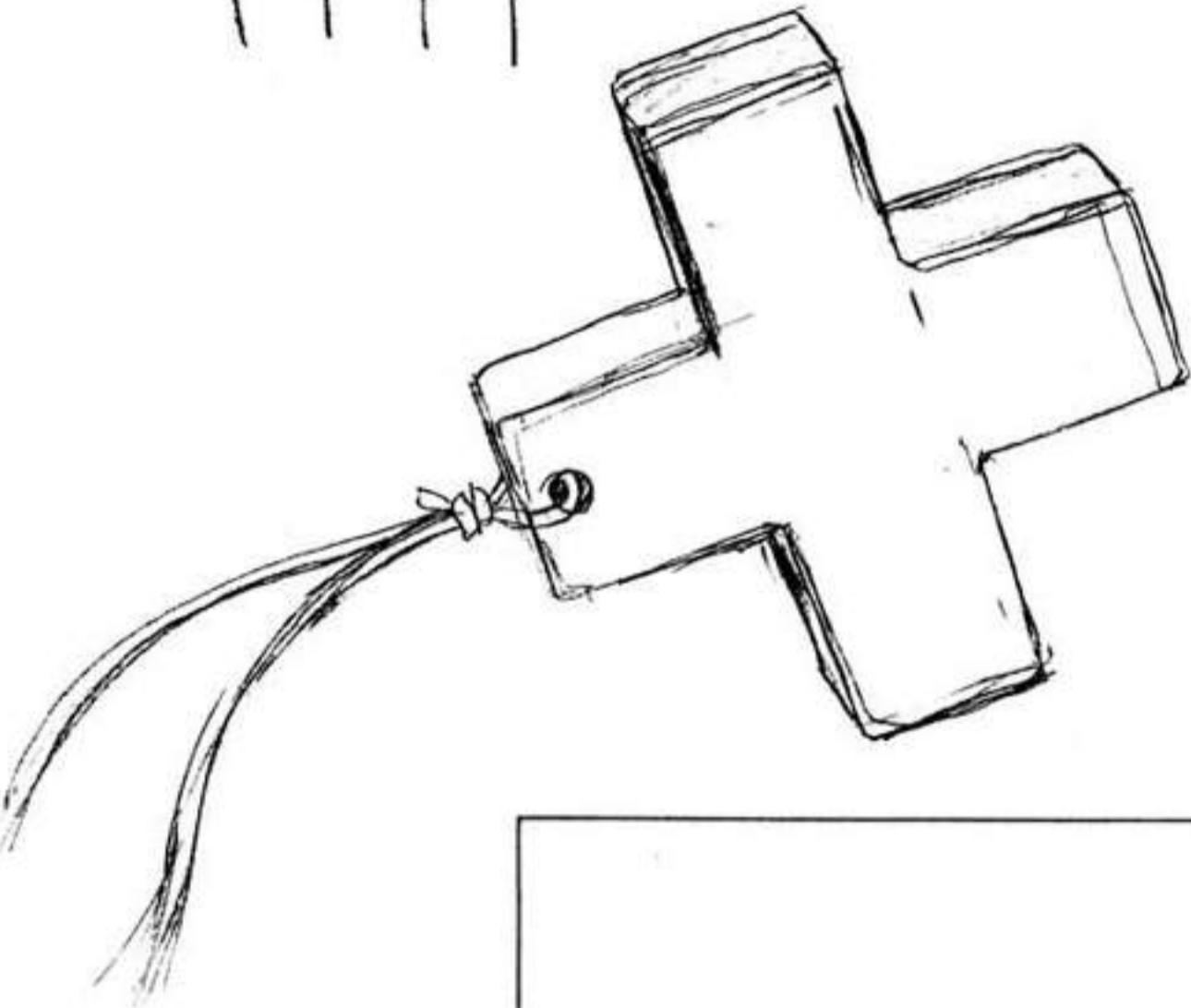

#26
7/7 コ 77
こんな感じで
23LC

昭和30年代
23LC

297 3/4

ビスとナット止め

研究生時代の破21

巨衣のFは
ハナコN姿(左F系統参照)

新#26

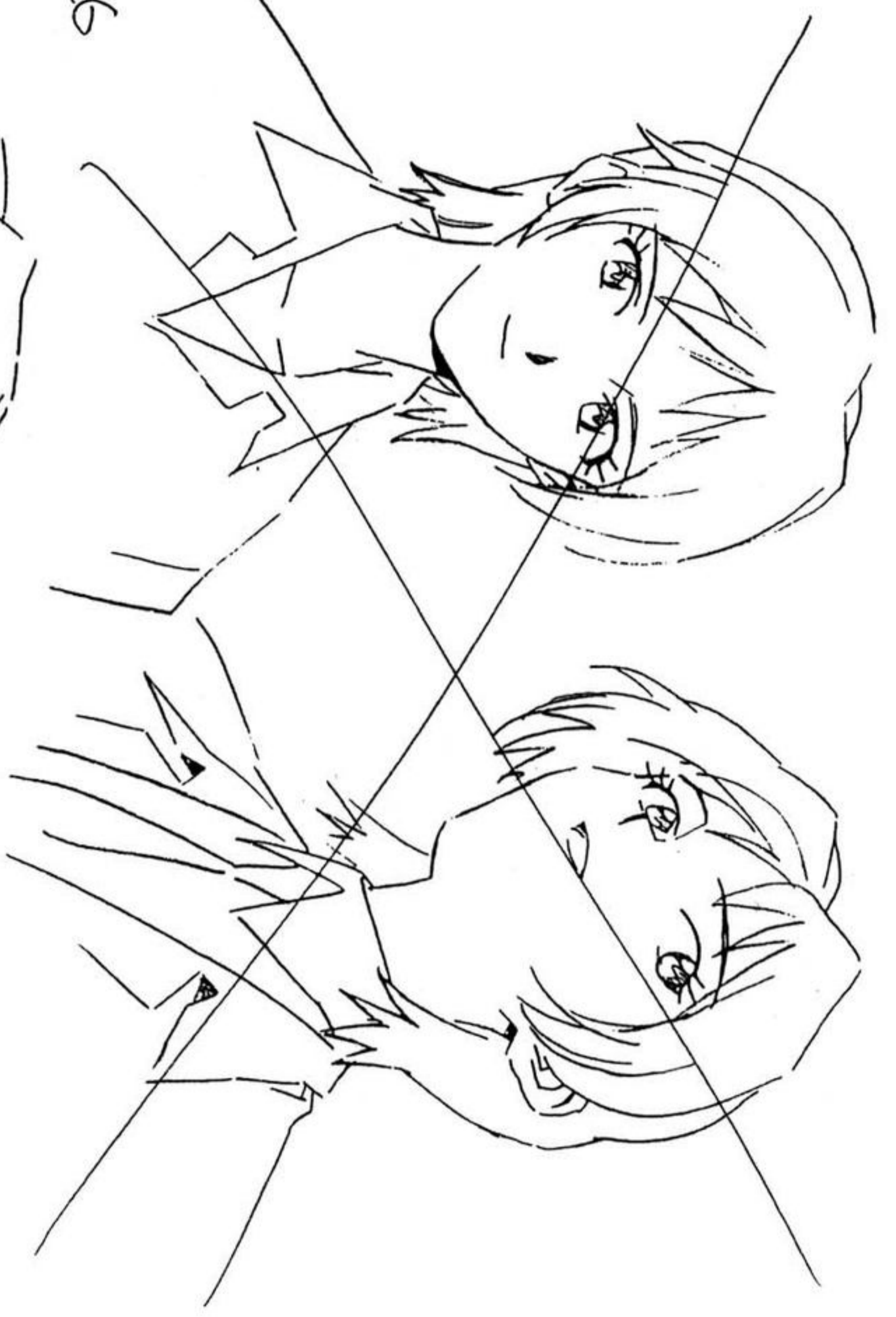

ビセルン
時代は
ハナコ

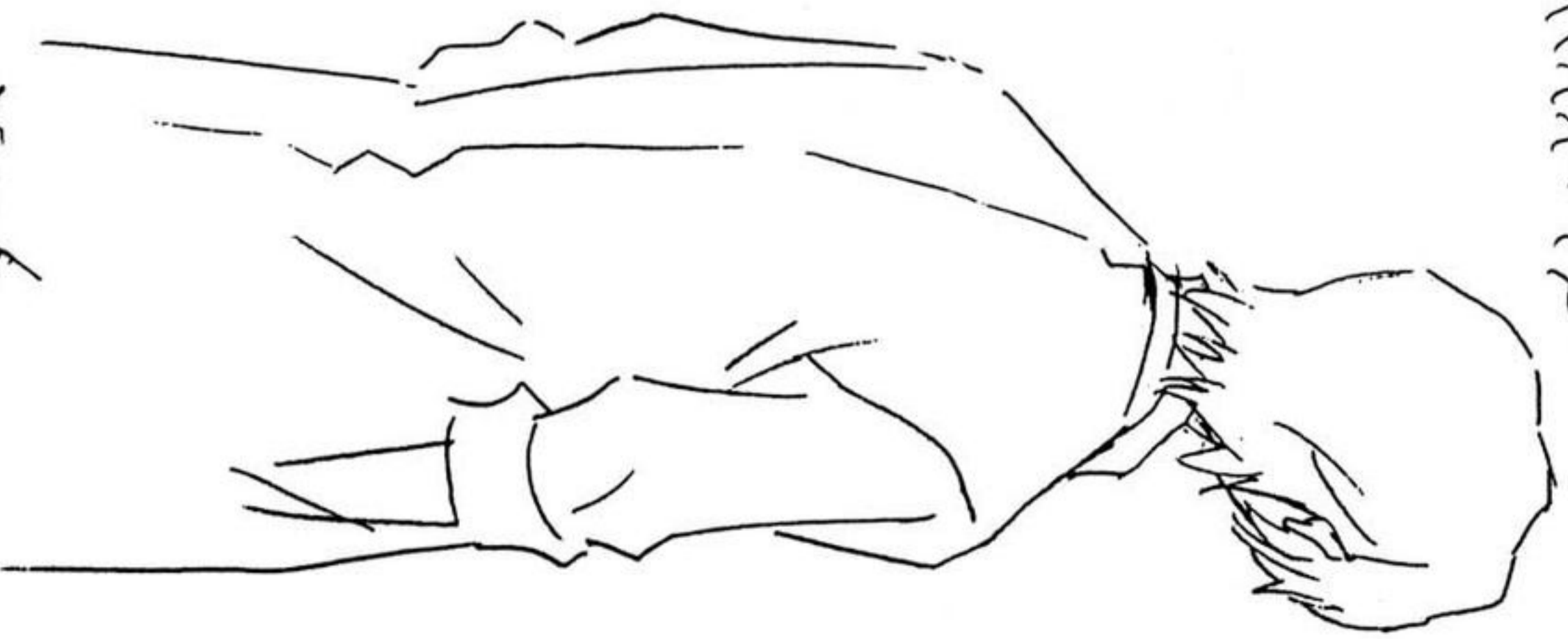
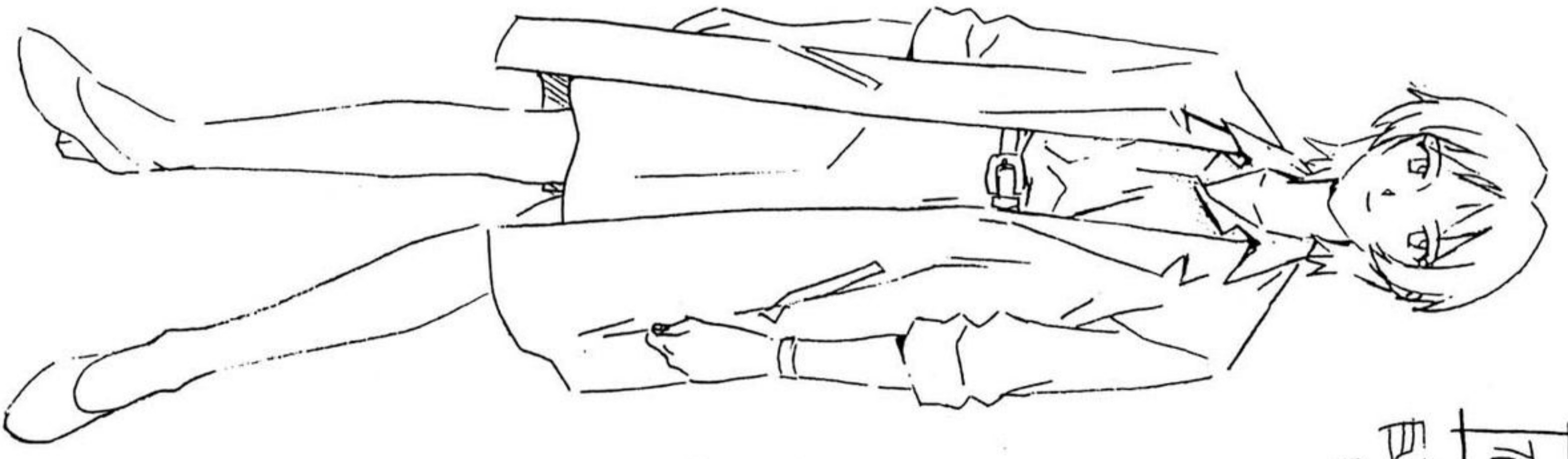

新#26

c-448~451

決定稿

決定稿



助教時代の冬月
~~講義の自叙~~



新#26

上着の
キヤナキ

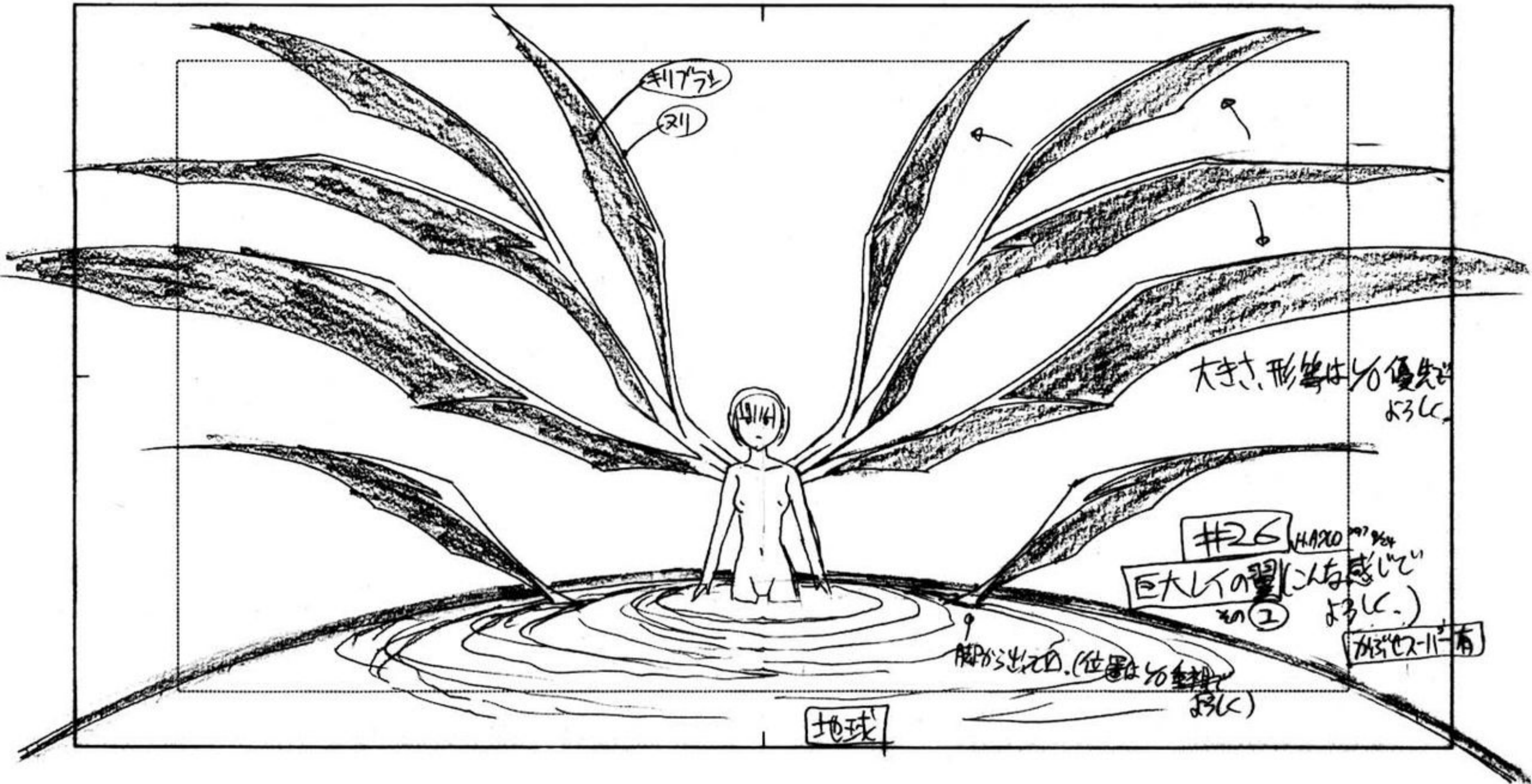

髪もW211です。

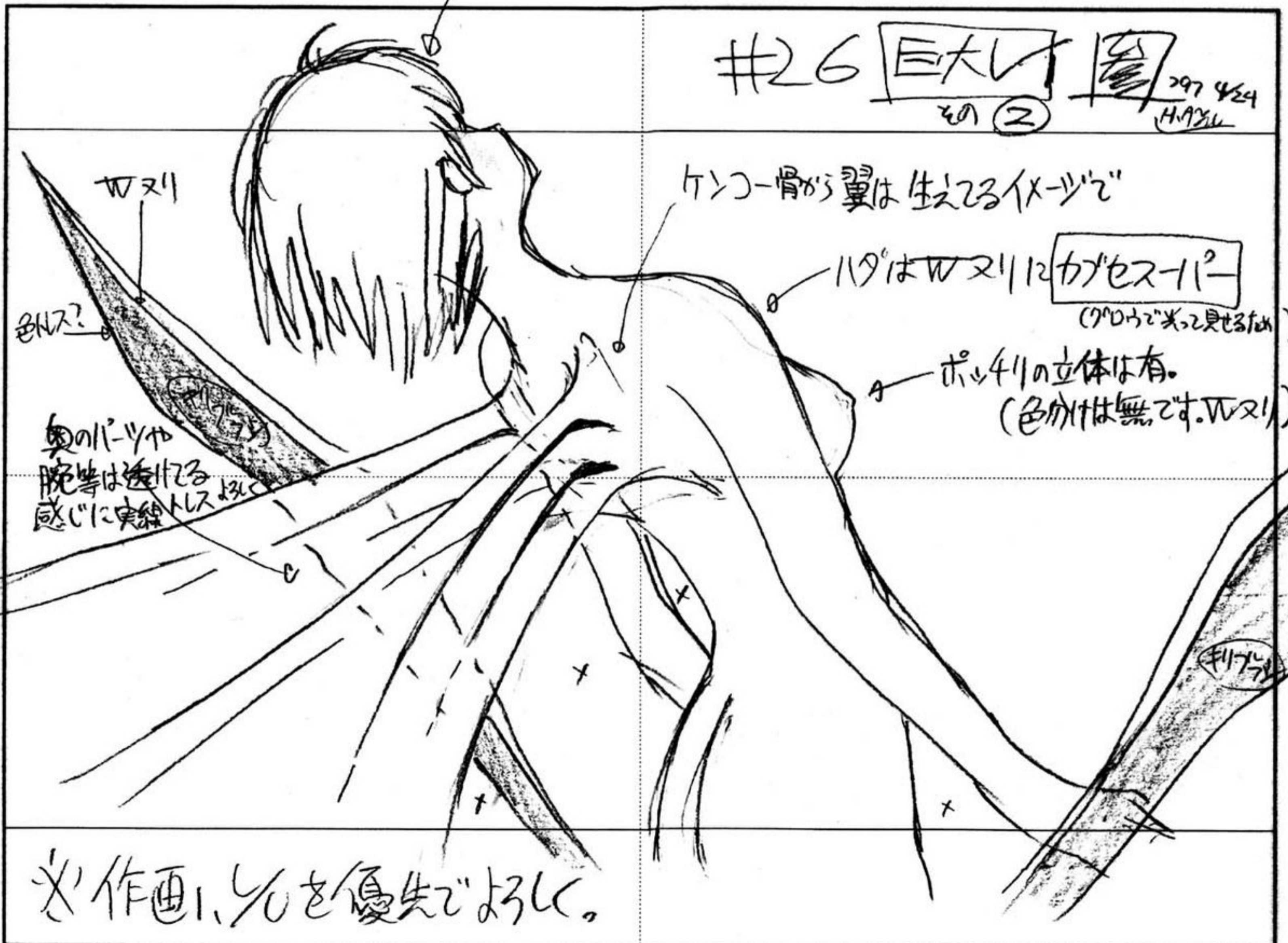

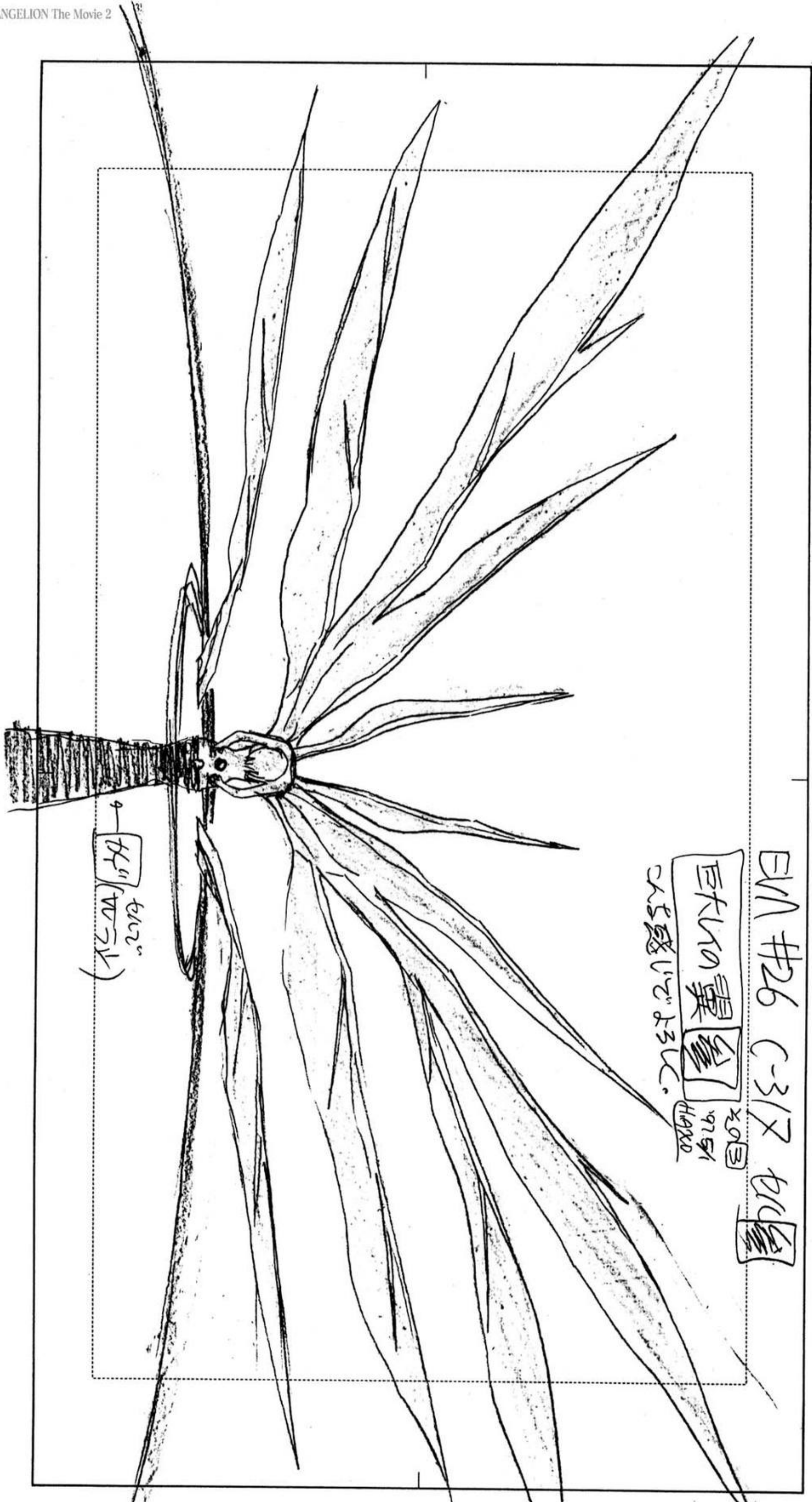

EVA #26 C-3/7 6/14

巨大の翼
 25歳位より
 2003
 1975/1
 H49X0

4
 64" (165cm)
 612"

Groundwork of EVANGELION The Movie 2

新世紀エヴァンゲリオン劇場版原画集 下巻

■まごころを、君に

作画監督

鈴木 俊二

平松 禎史

庵野 秀明

26 作画監督補佐

古川 尚哉

吉成 曜

26 原画 (五十音順)

庵野 秀明 今石 洋之 入好 さとる 小倉 陳利 亀井 幹太

河口 俊夫 黒沢 守 後藤 隆幸 牛来 隆行 佐々木 守

杉浦 幸次 高橋 英樹 丹澤 学 坪内 克幸 戸倉 紀元

中山 勝一 野田 武広 橋本 敬史 長谷川 眞也 平井 久司

平松 禎史 古川 尚哉 星 和伸 摩砂雪 増尾 昭一

もりやま ゆうじ 吉成 曜

新世紀エヴァンゲリオン劇場版原画集 下巻 特典

#26-新 007
修正原画

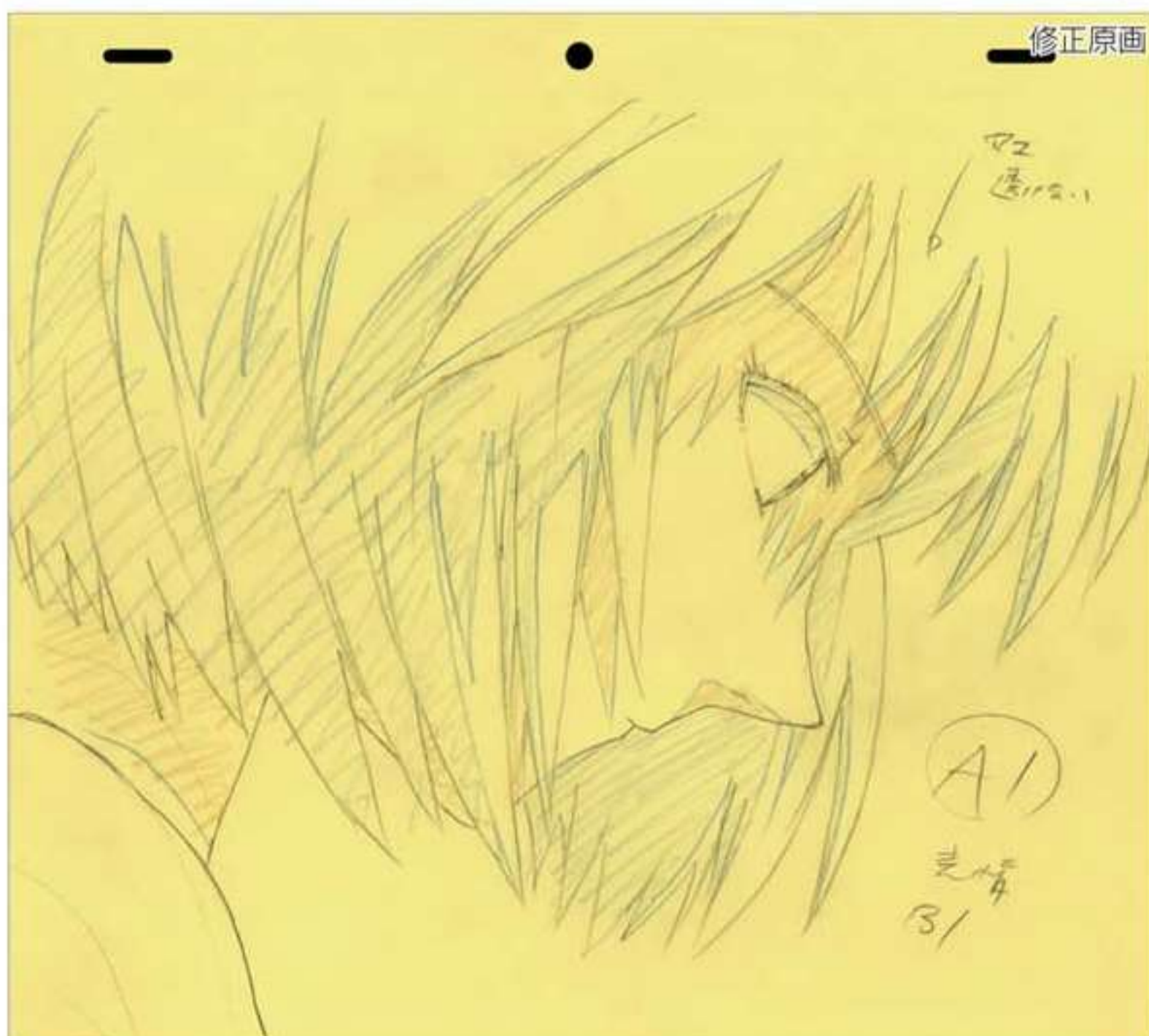
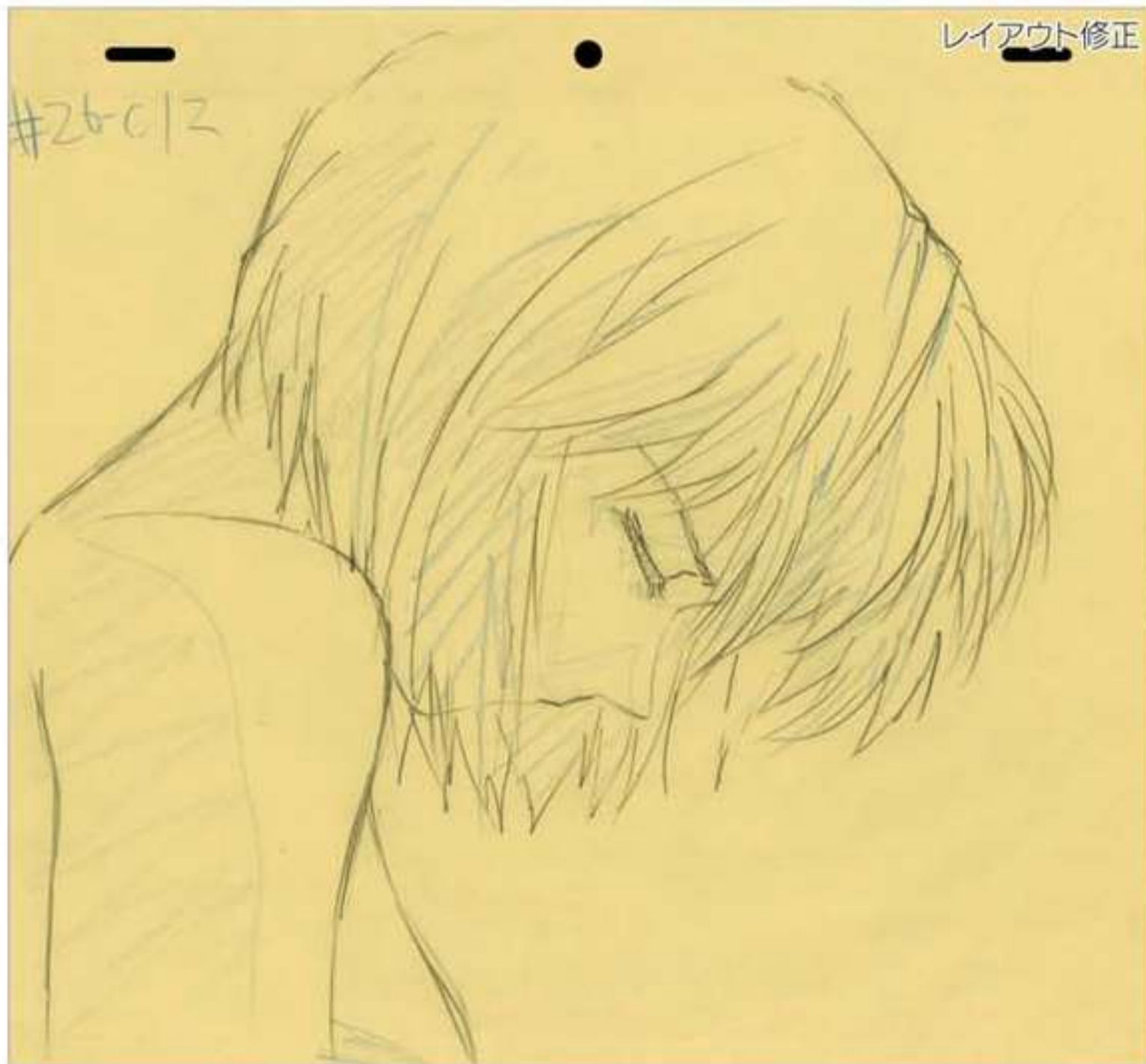

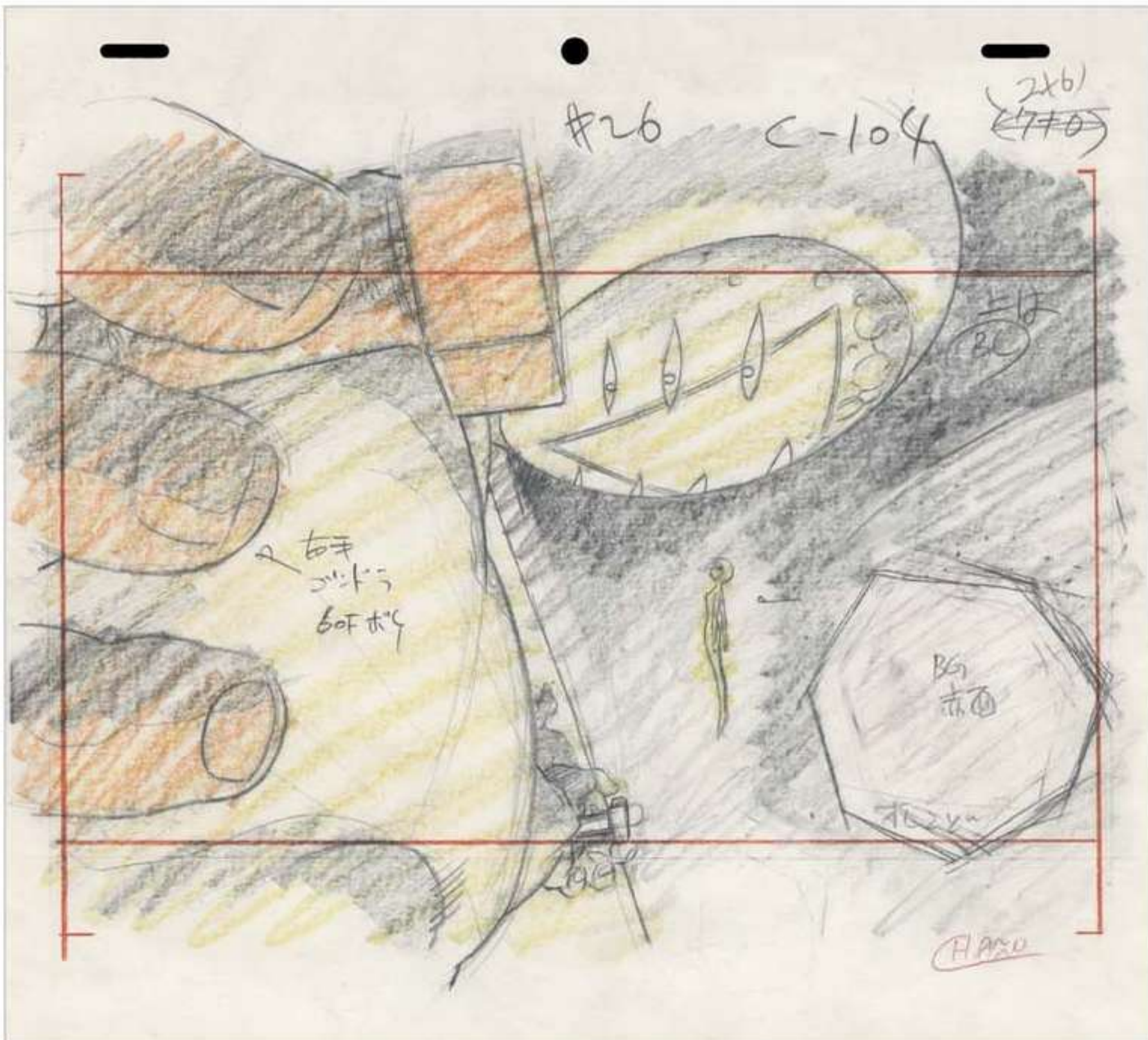
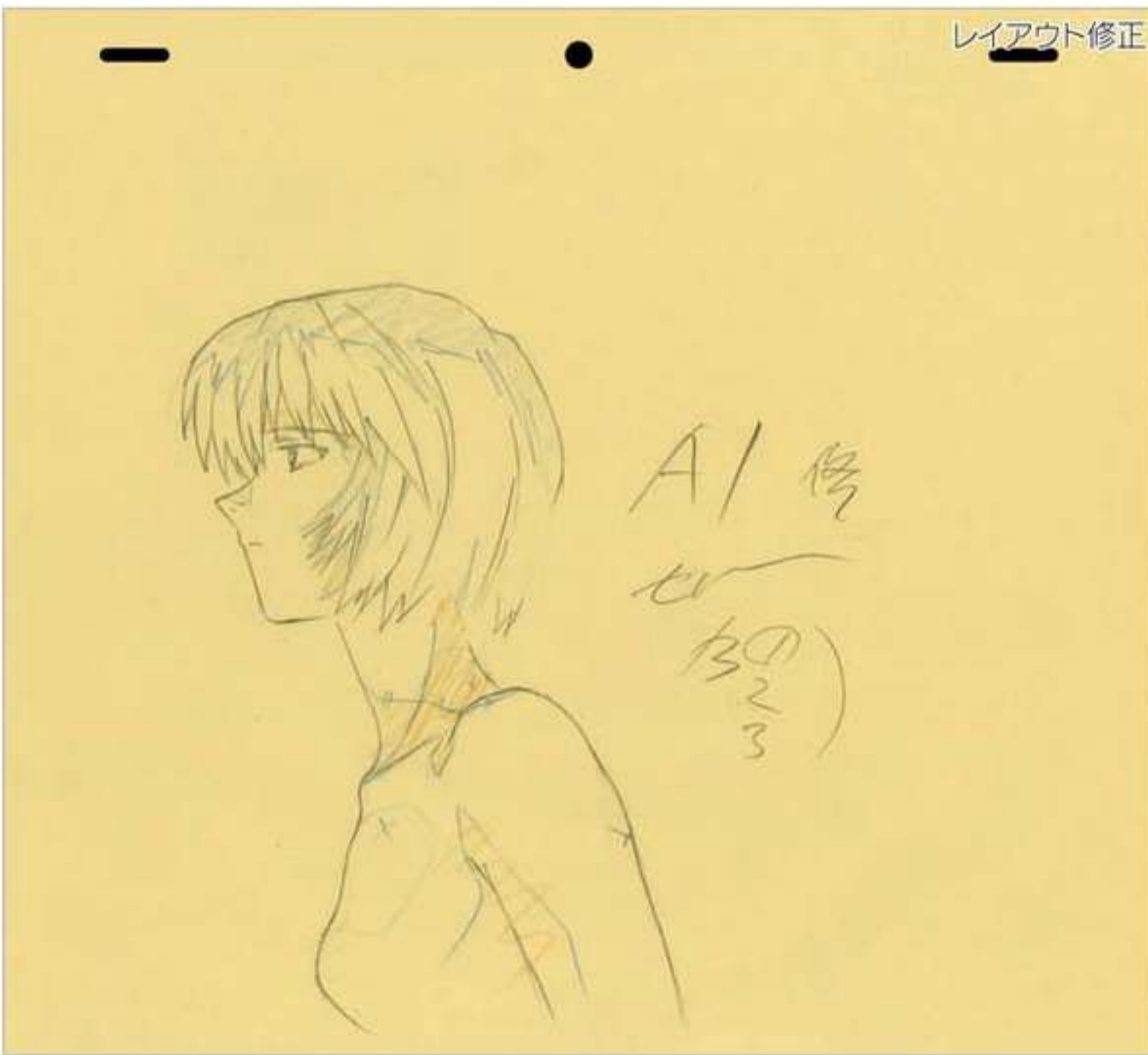
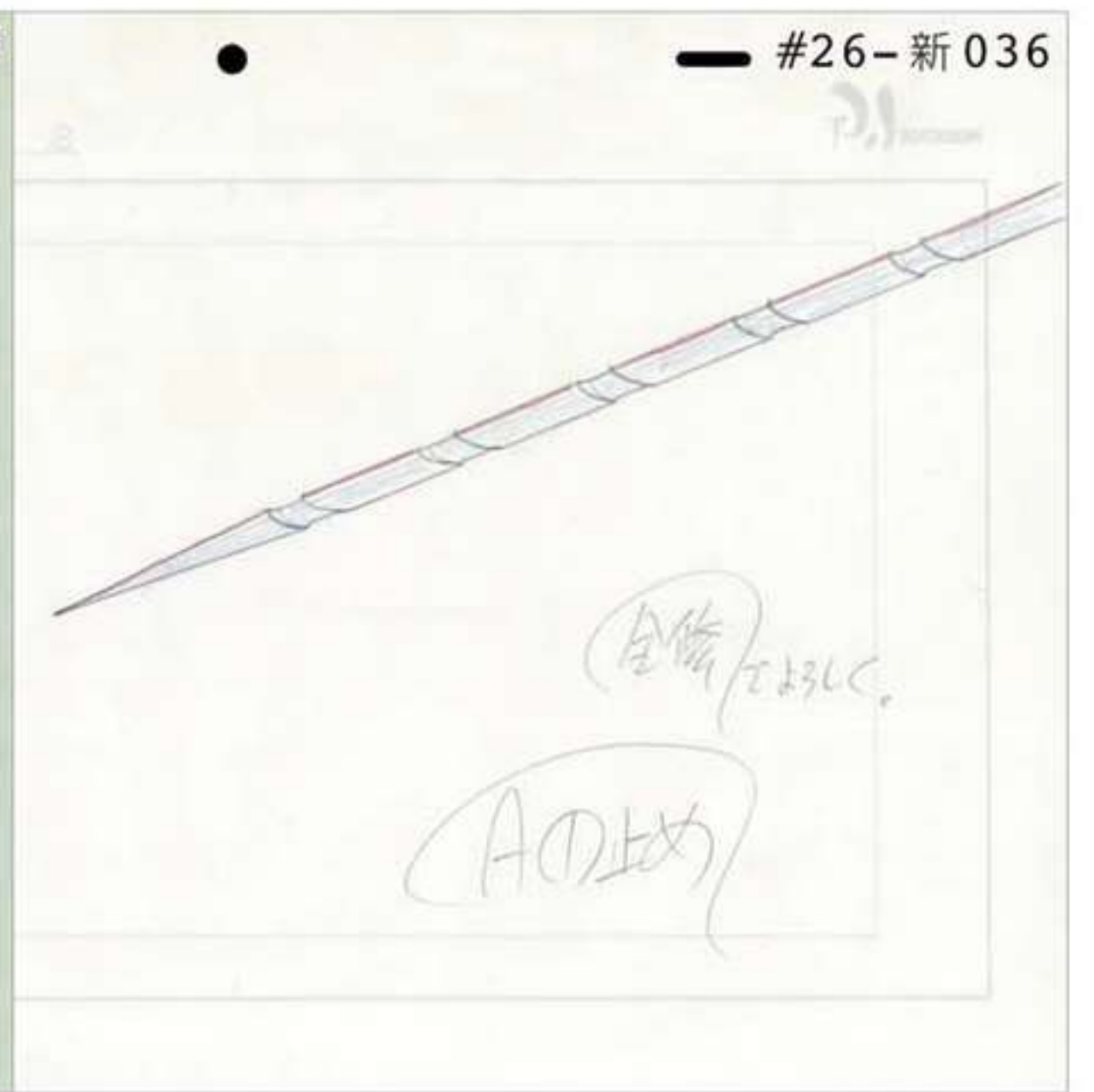

レイアウト修正



PRODUCTION I.G

#26-新122
レイアウト

s. 26 c. 122 TIME

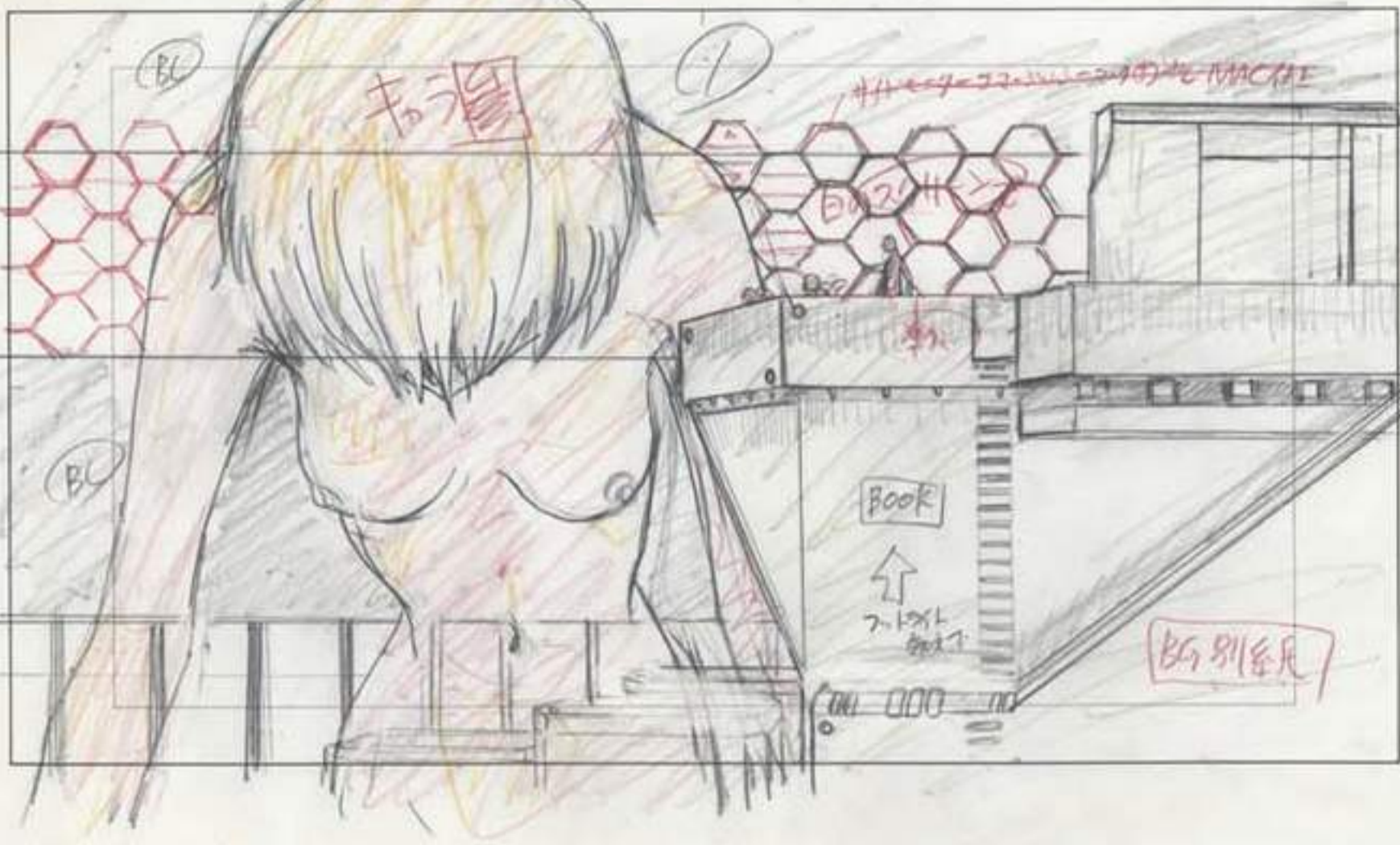

修正原画



#26-新124A
修正原画



修正原画



#26-新124C
レイアウト

s. #26 c. 124C

TIME 2:12 PRODUCTION I.G



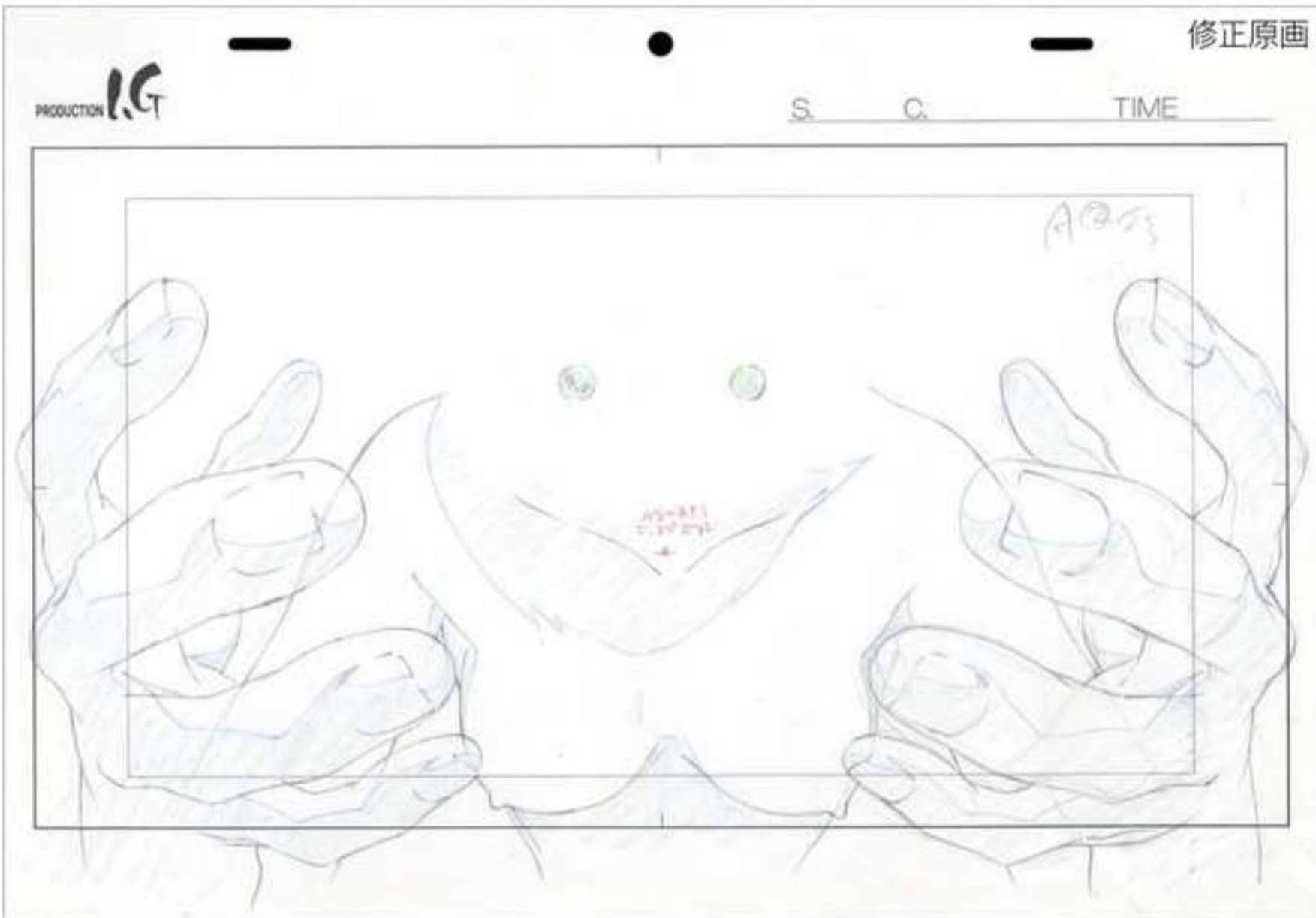
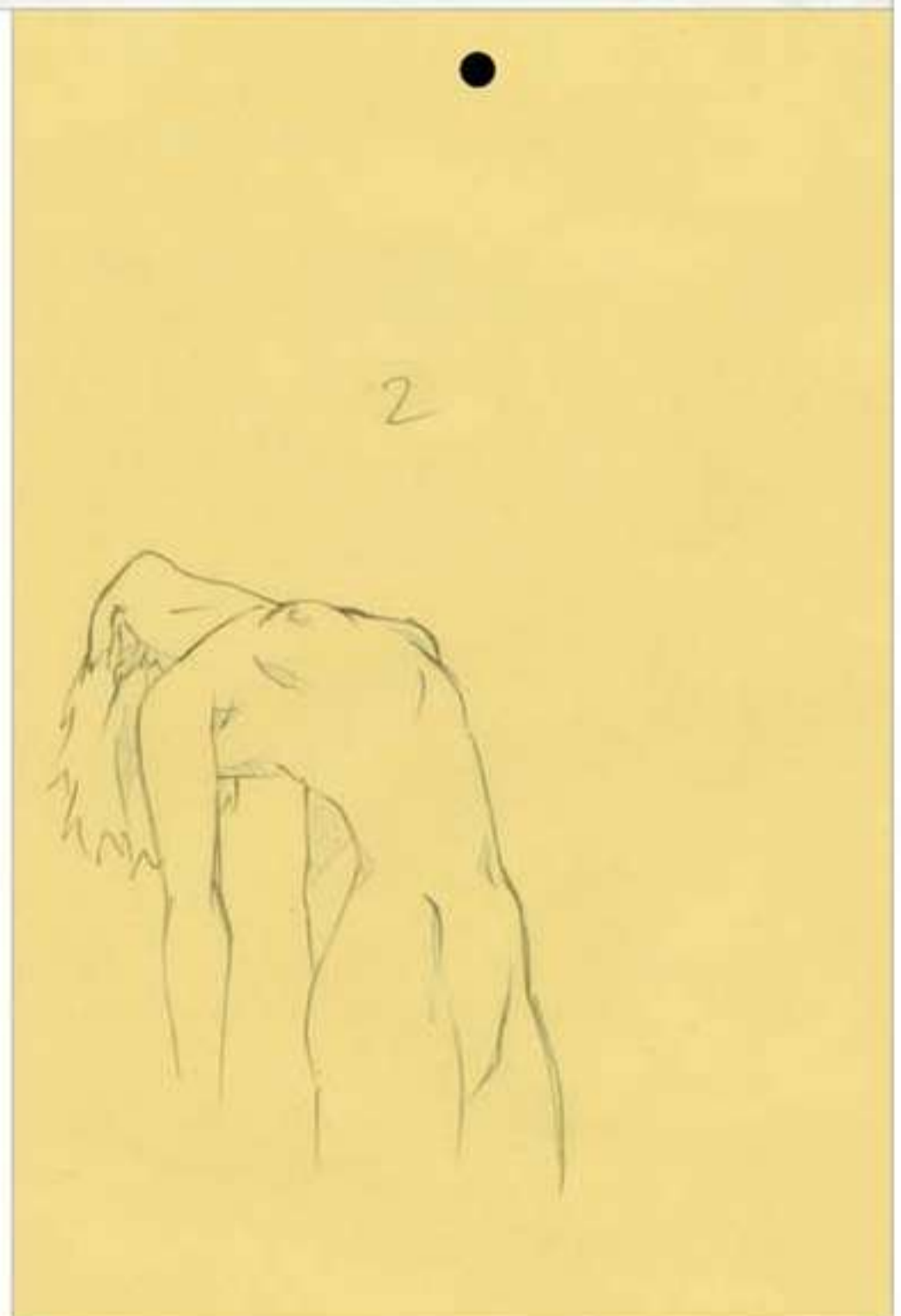
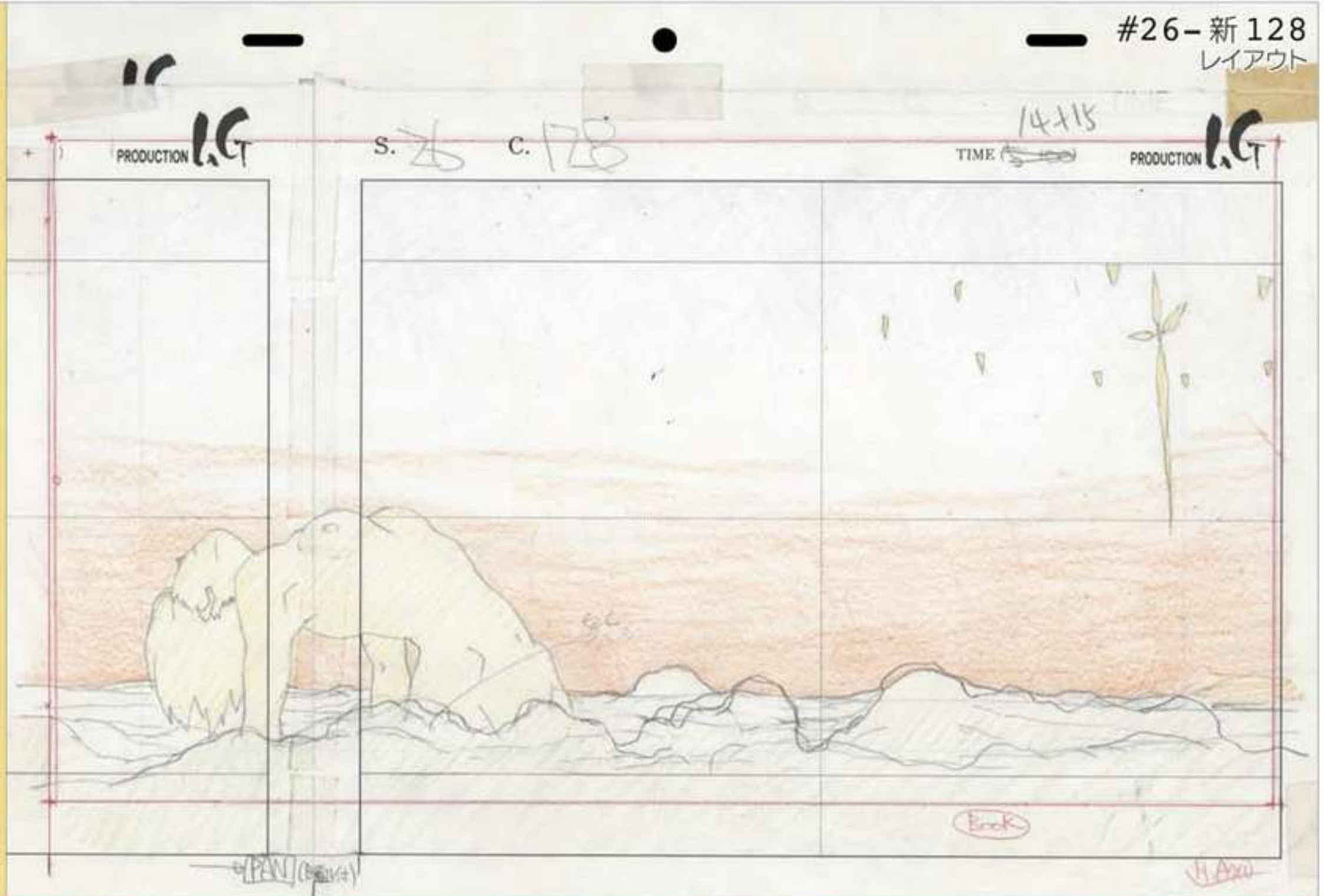

レイアウト修正

ア) 顔の作りかたはいいか?
顔の描きかた、髪の色はいいか?



ア) 顔の作りかたはいいか?
「お虫こぎ」加味はいい
と、うー

お
お虫こぎ

お虫こぎの顔

ALS

修正原画



15

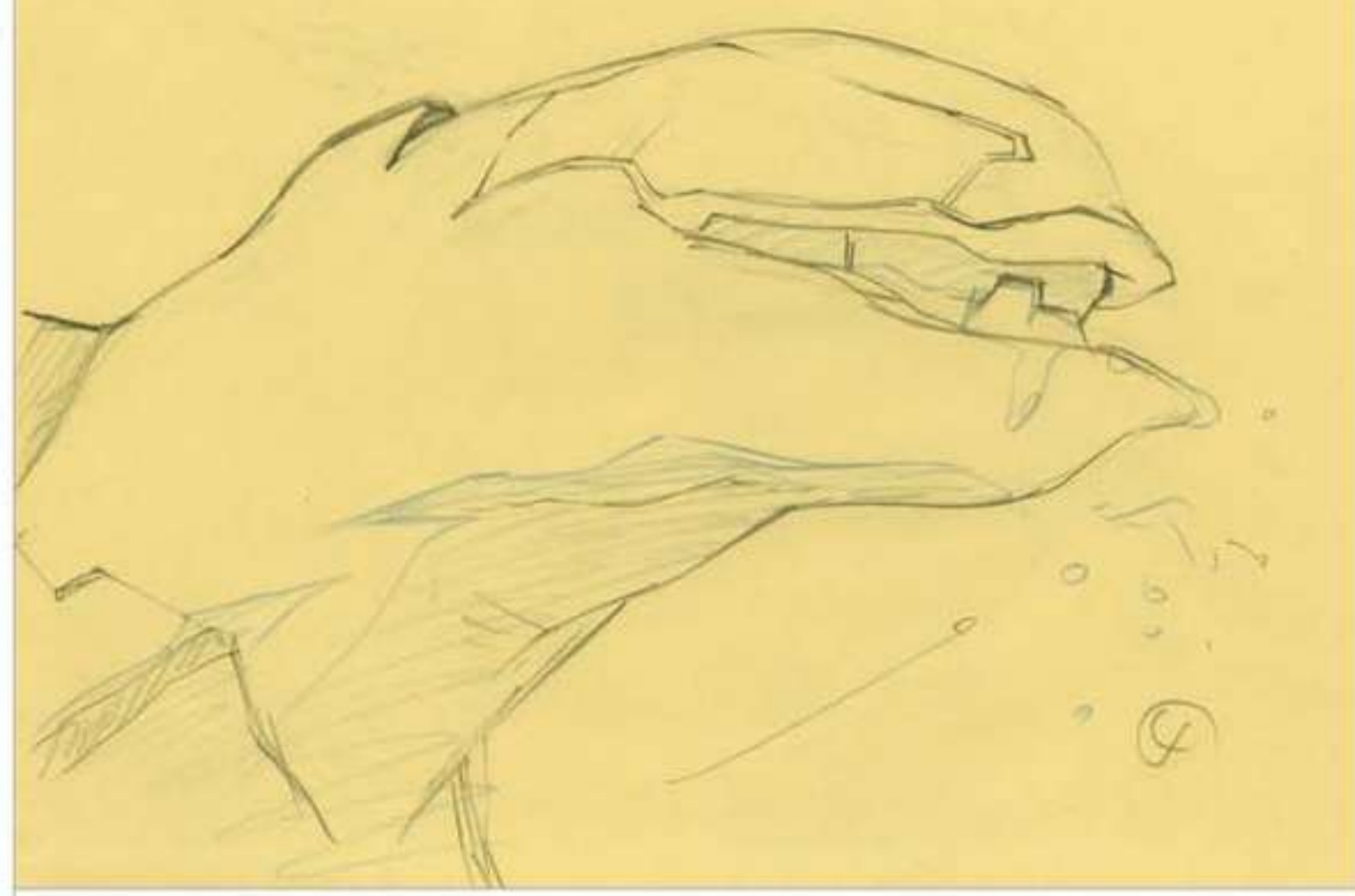

A5

今夜
お虫こぎ
お虫

修正原画



A5



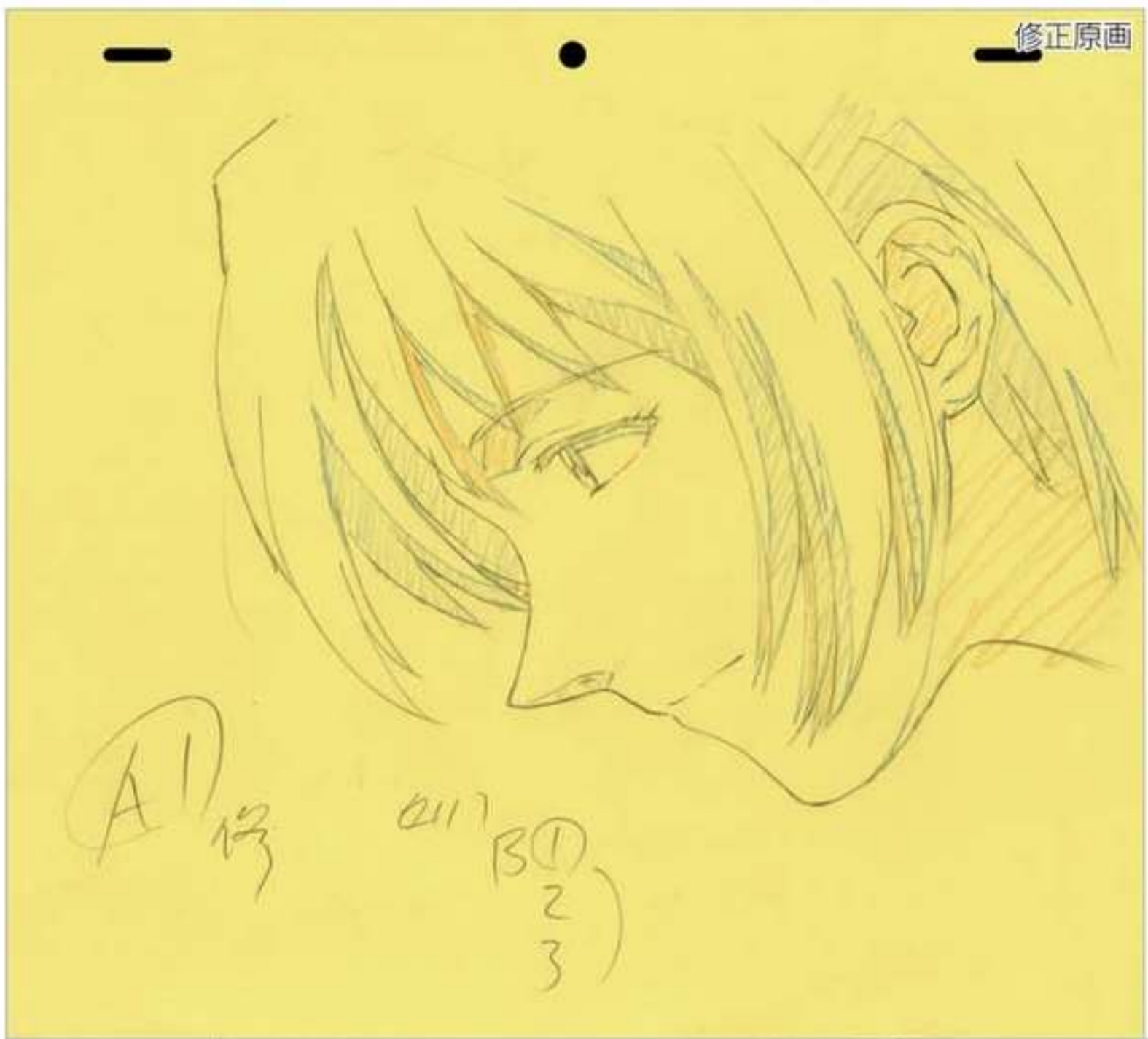
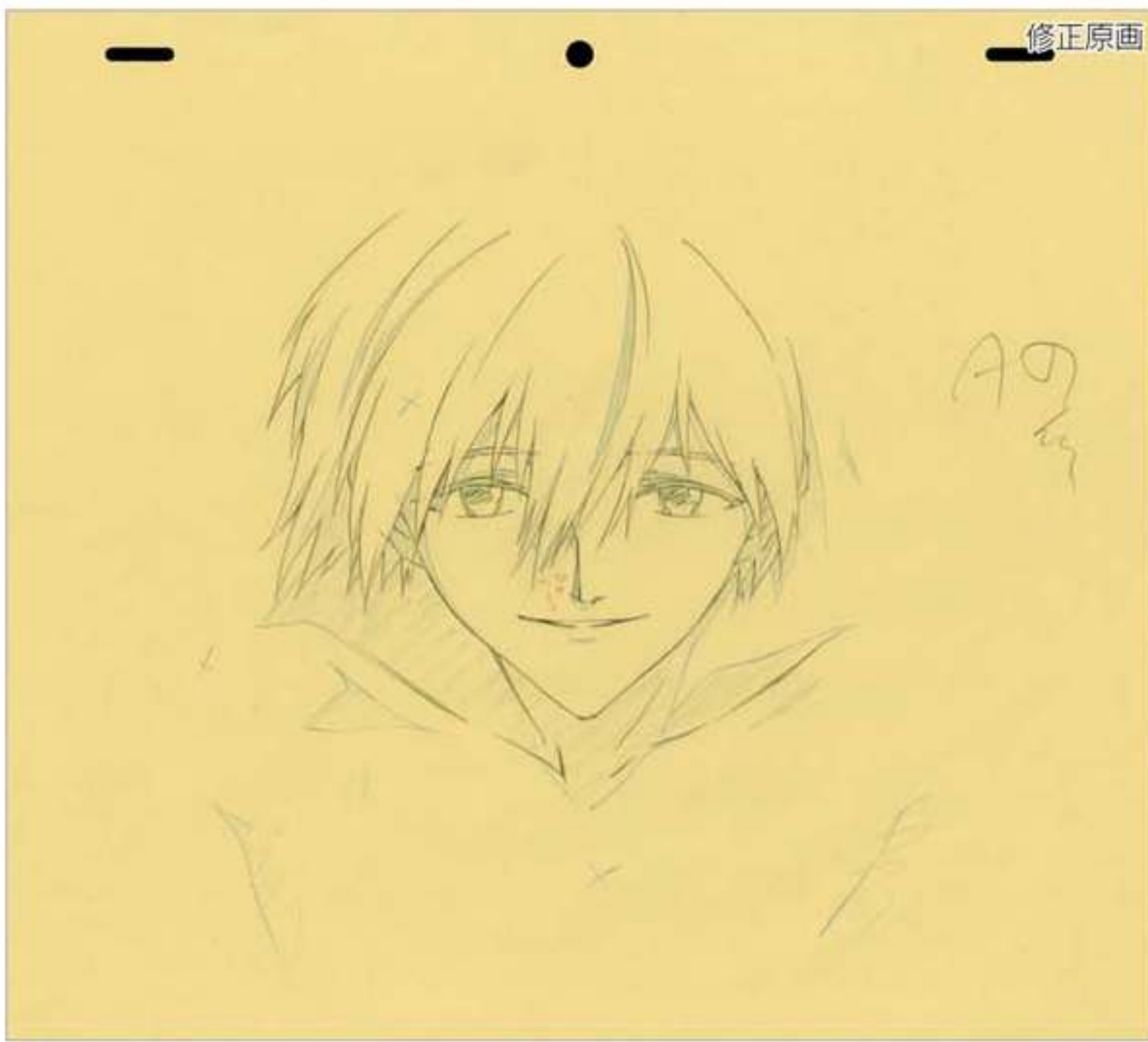

#26-新 196
レイアウト修正



#26-新 194
レイアウト

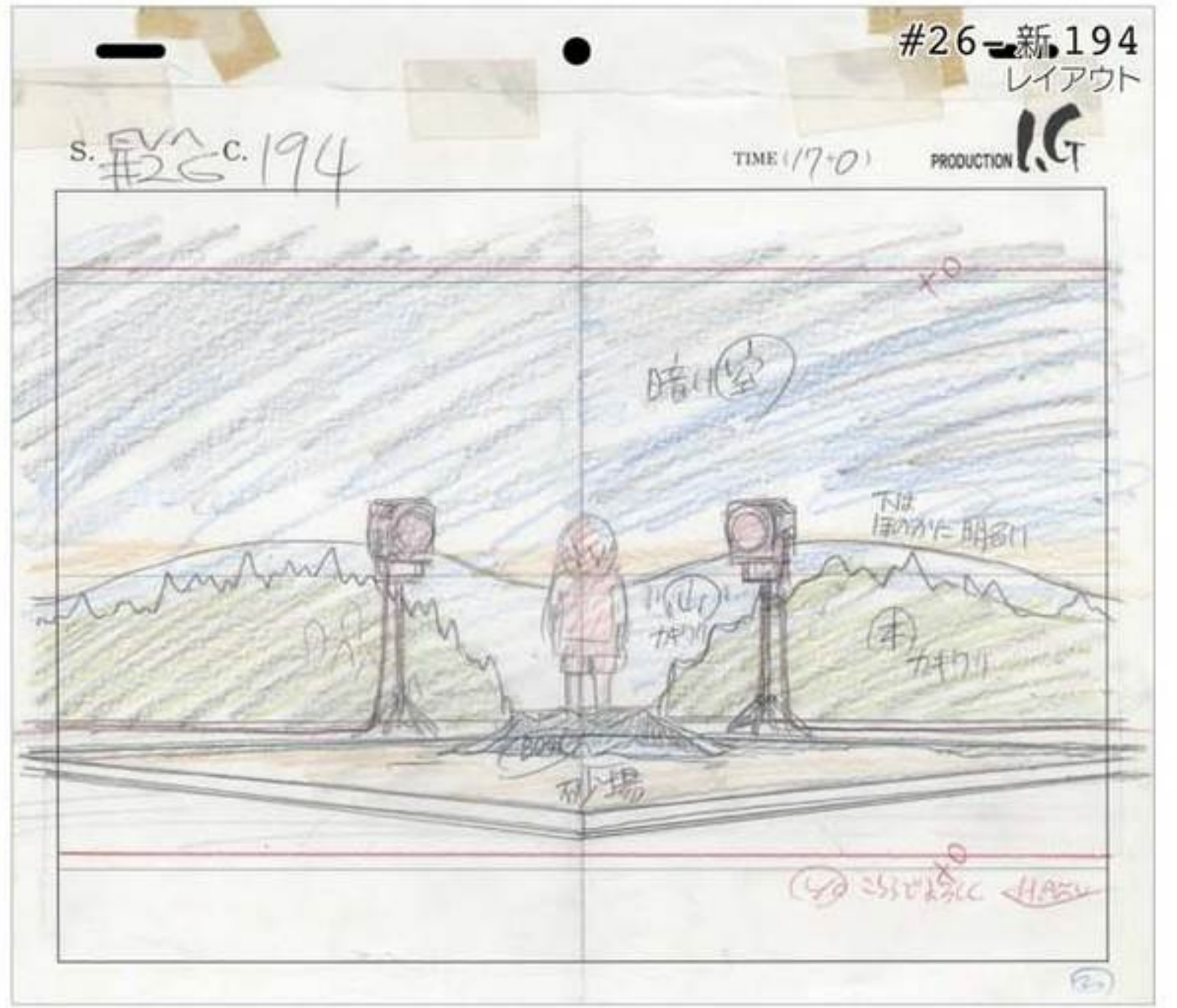

修正原画



#26-新 230
レイアウト





#26-新 259
修正原画

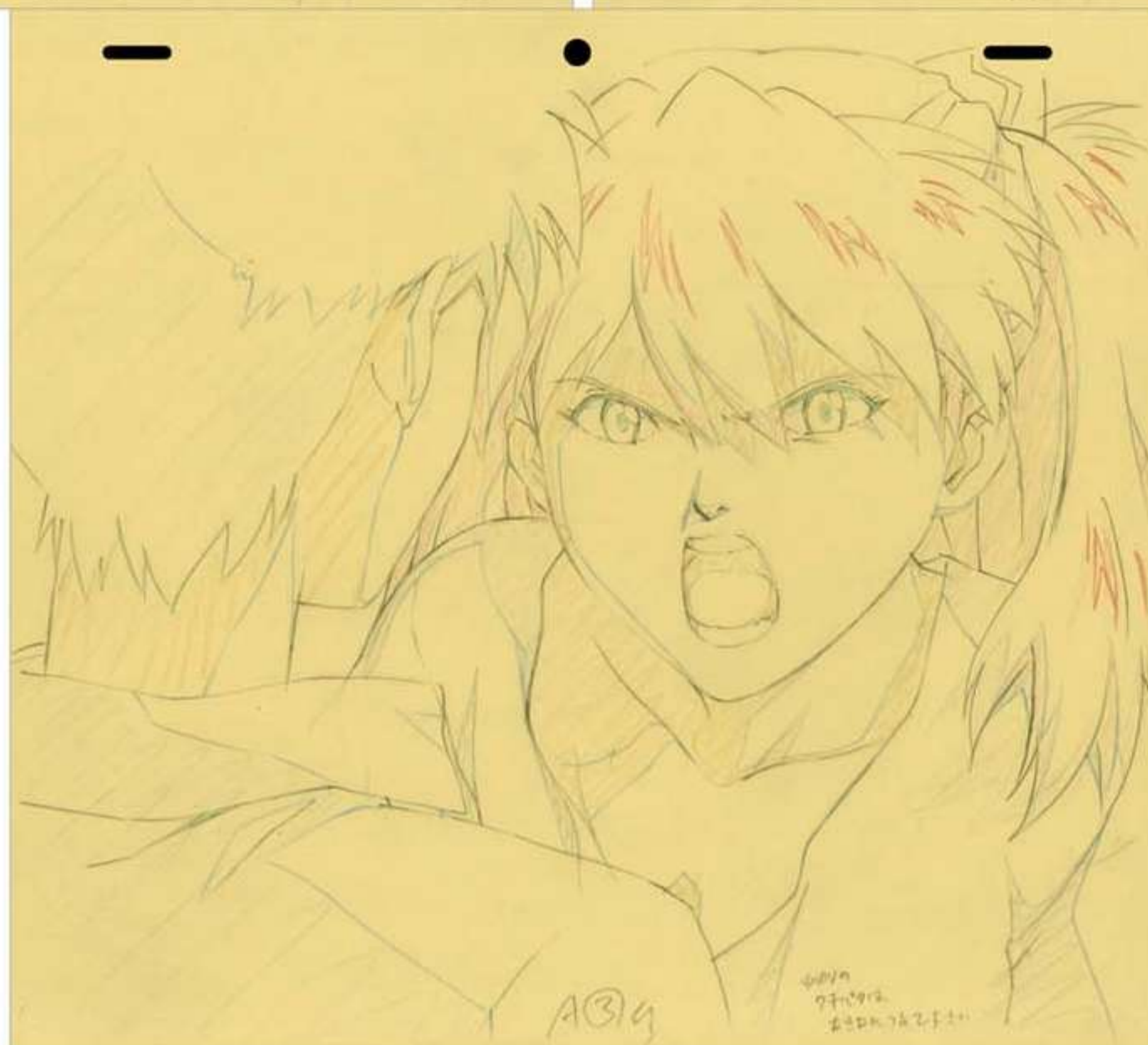

#26-新 259
タイムシート





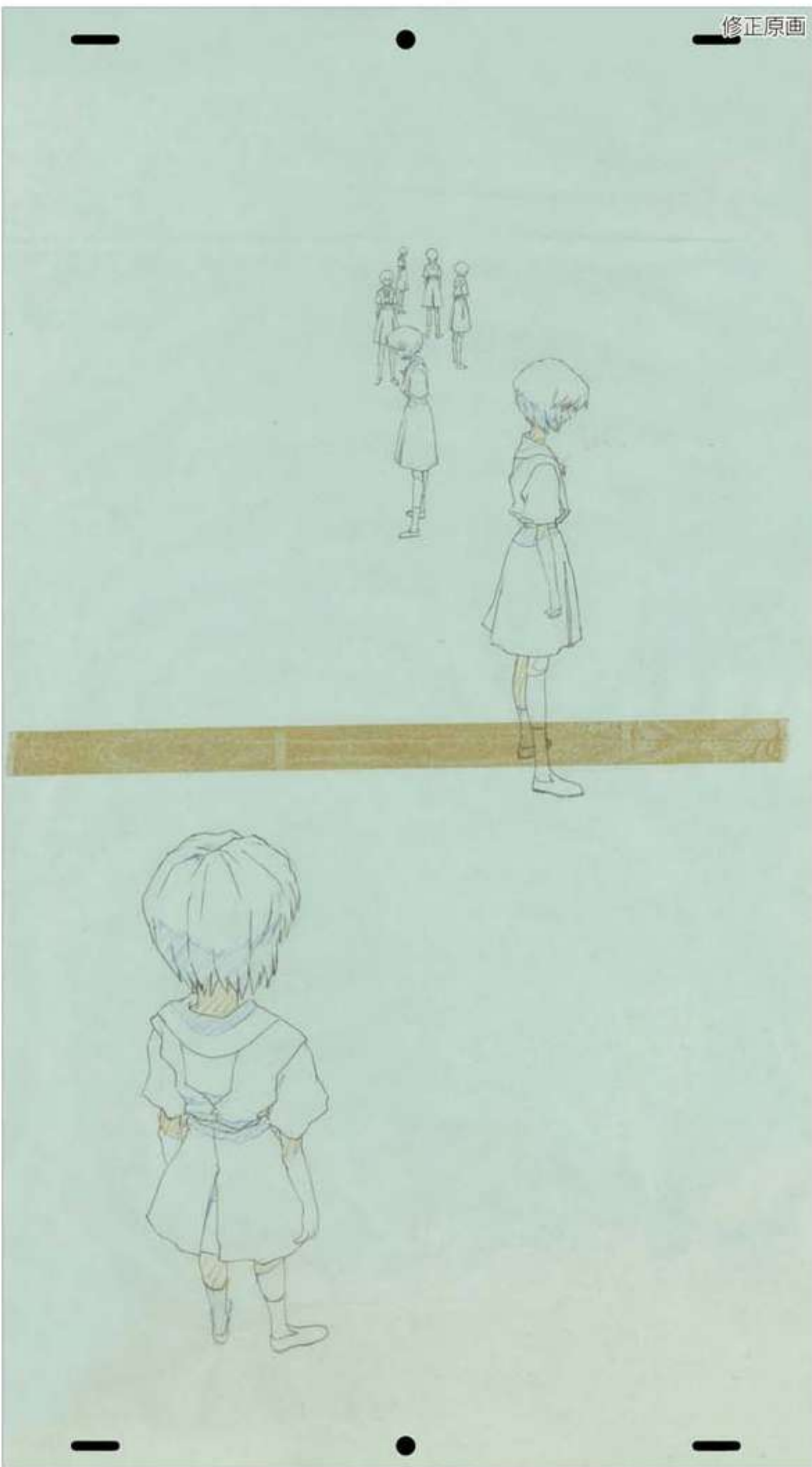

A/E



B/E



A/E





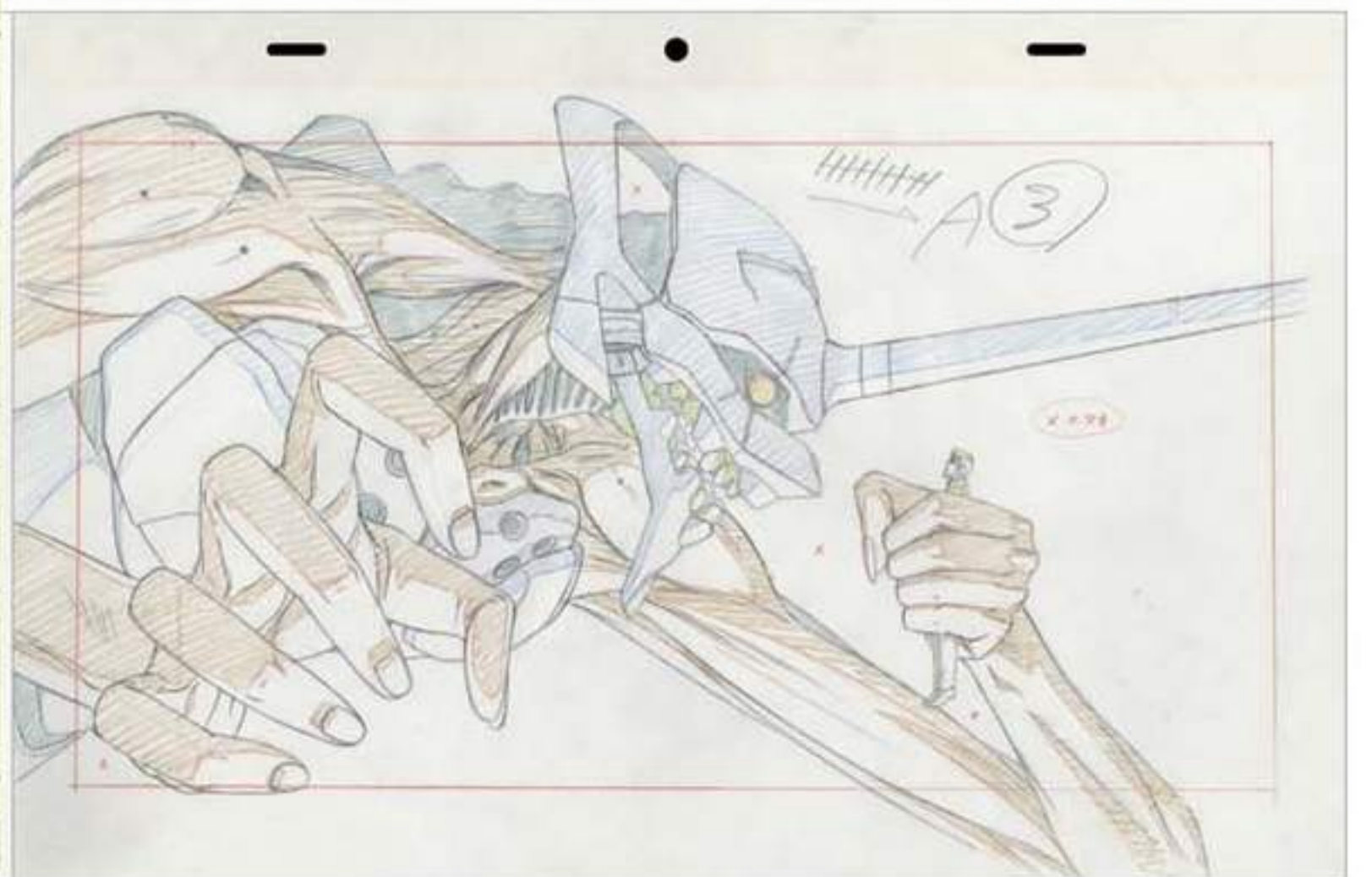
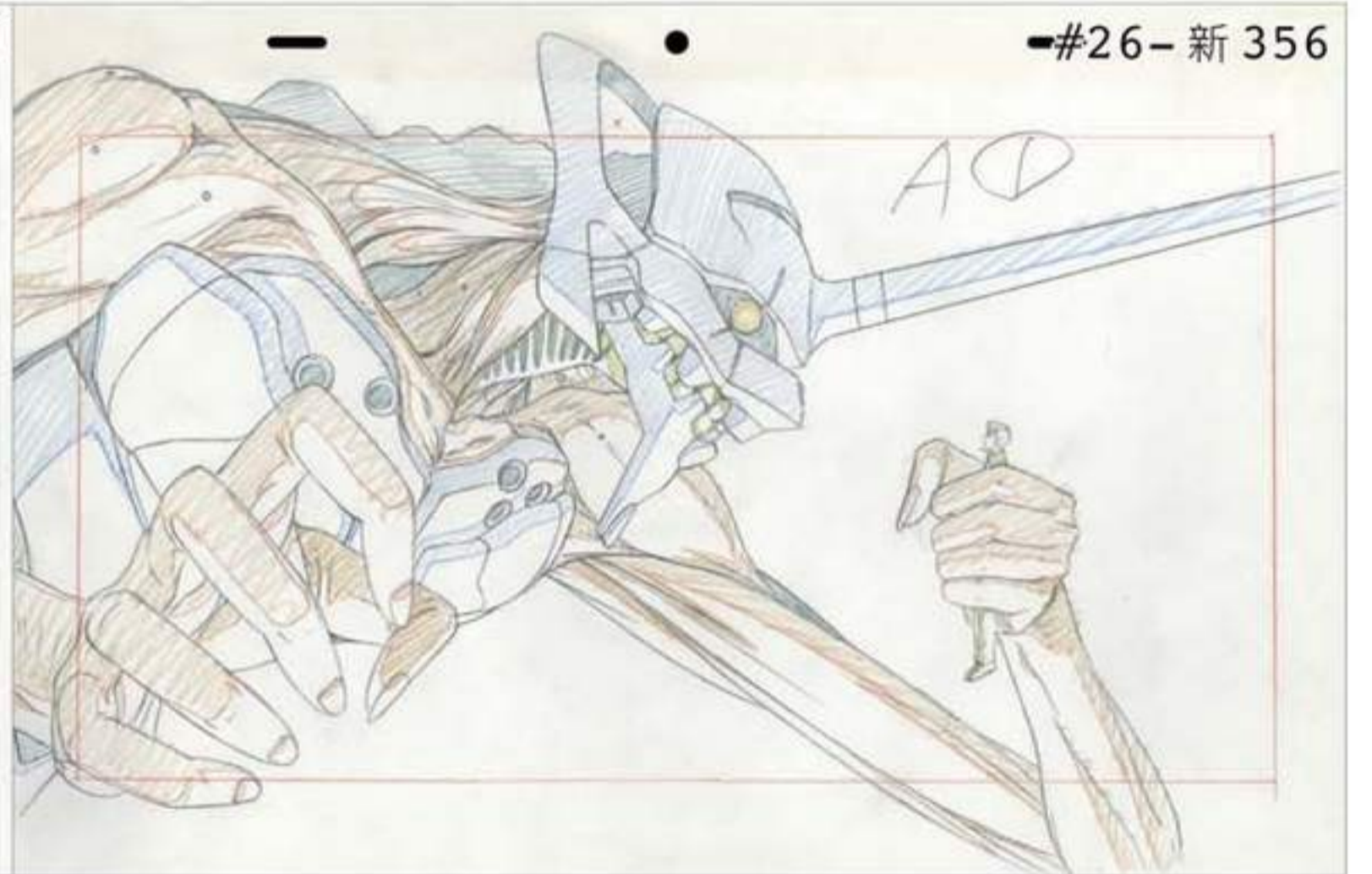
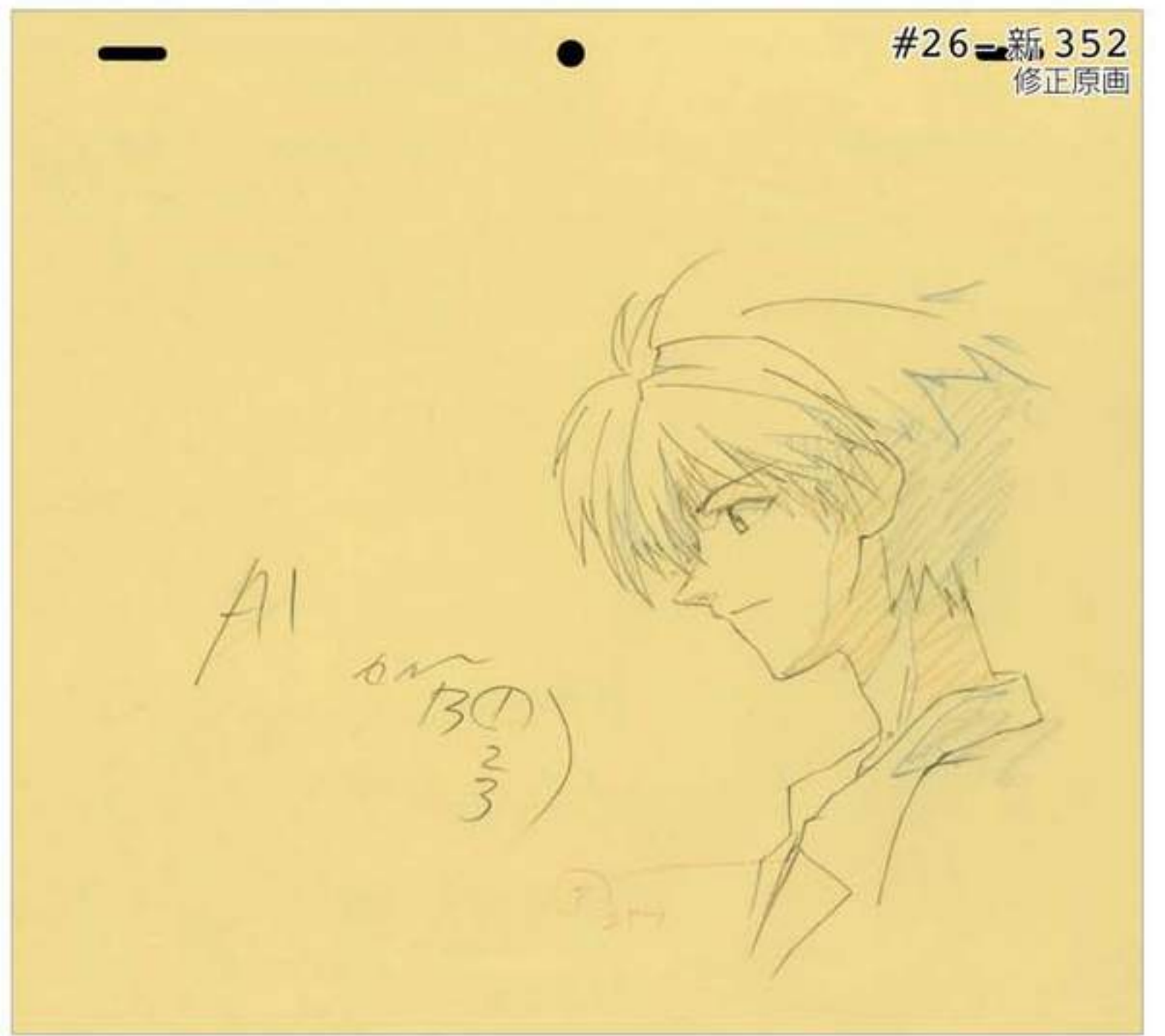
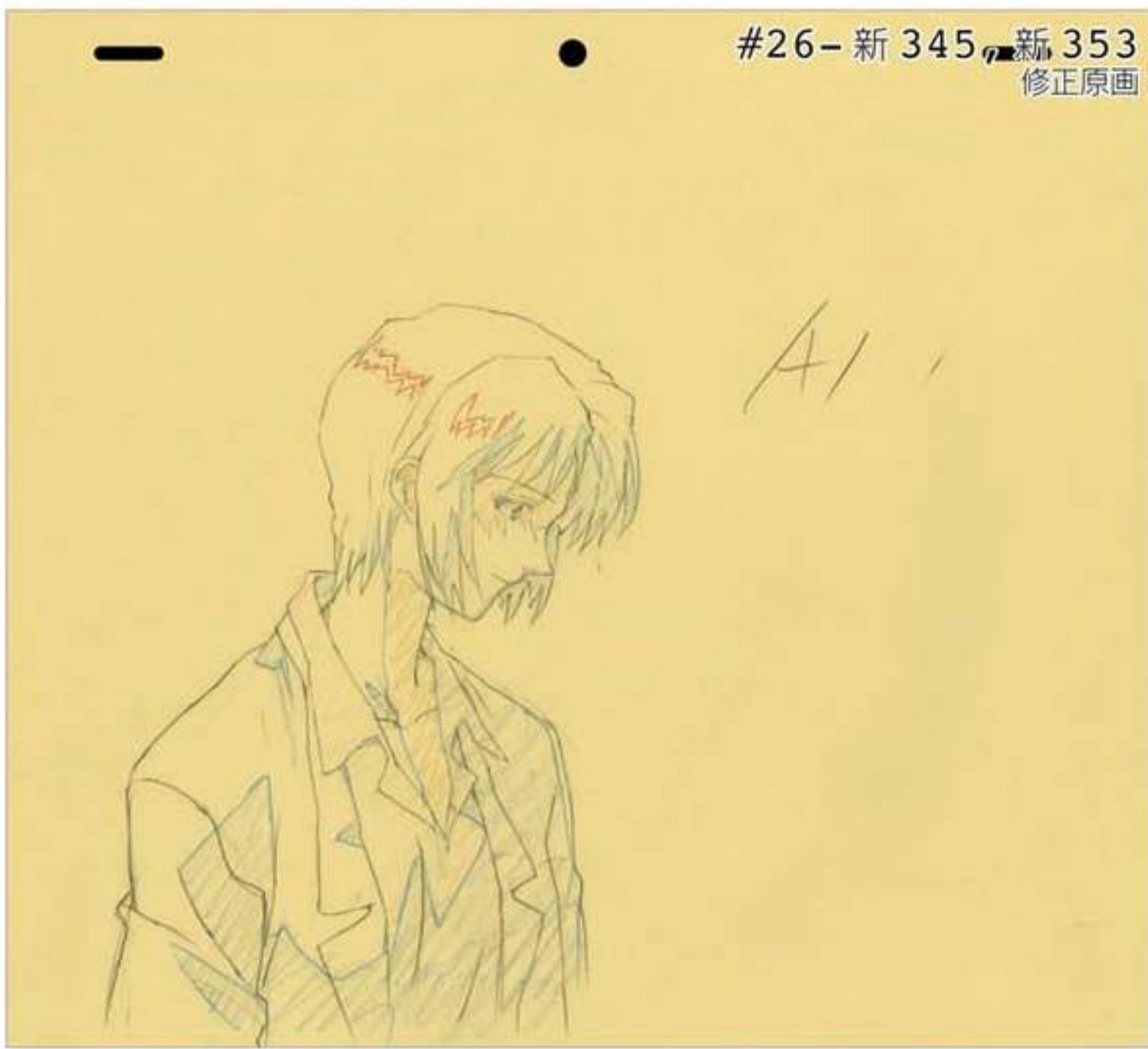

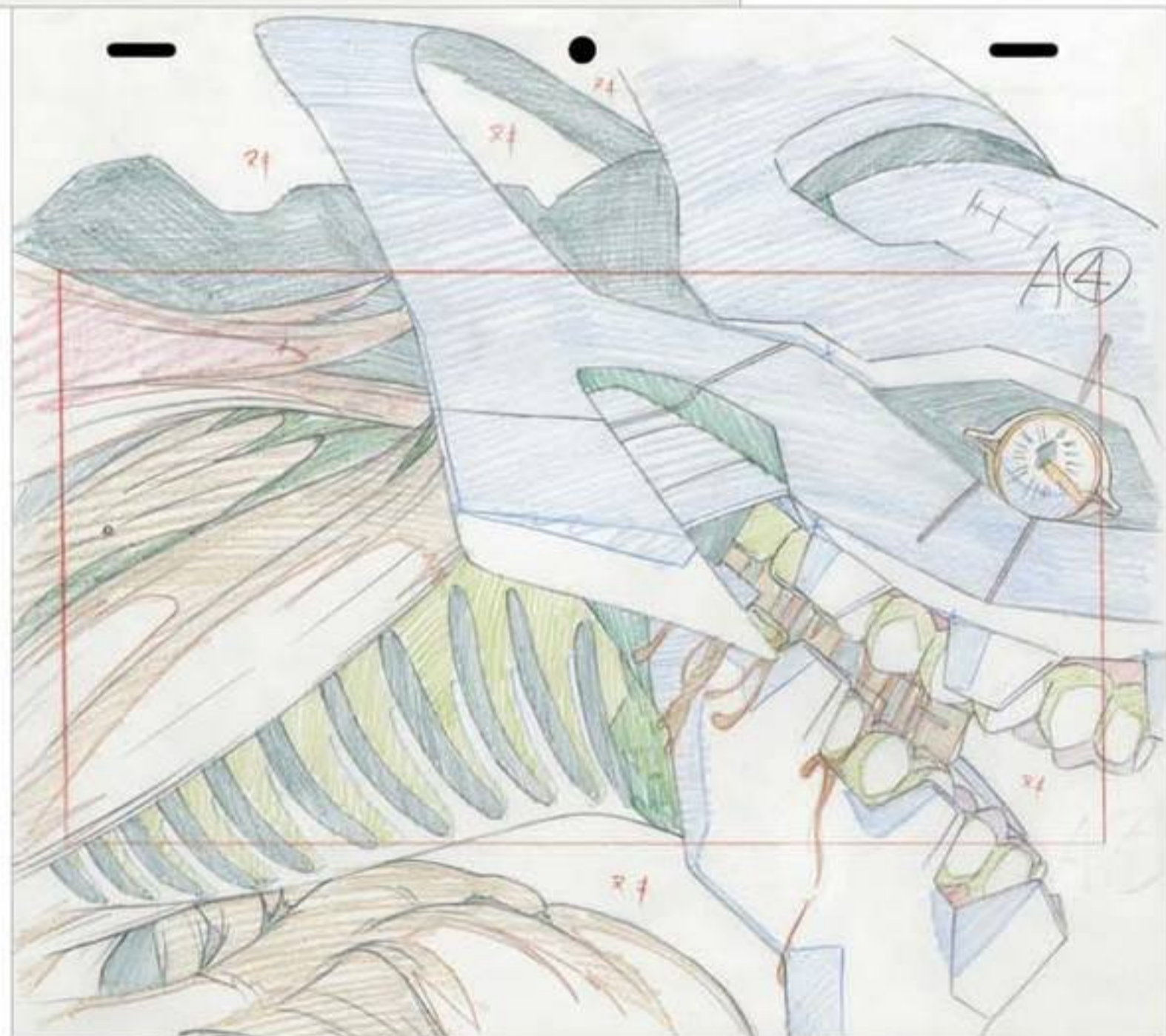
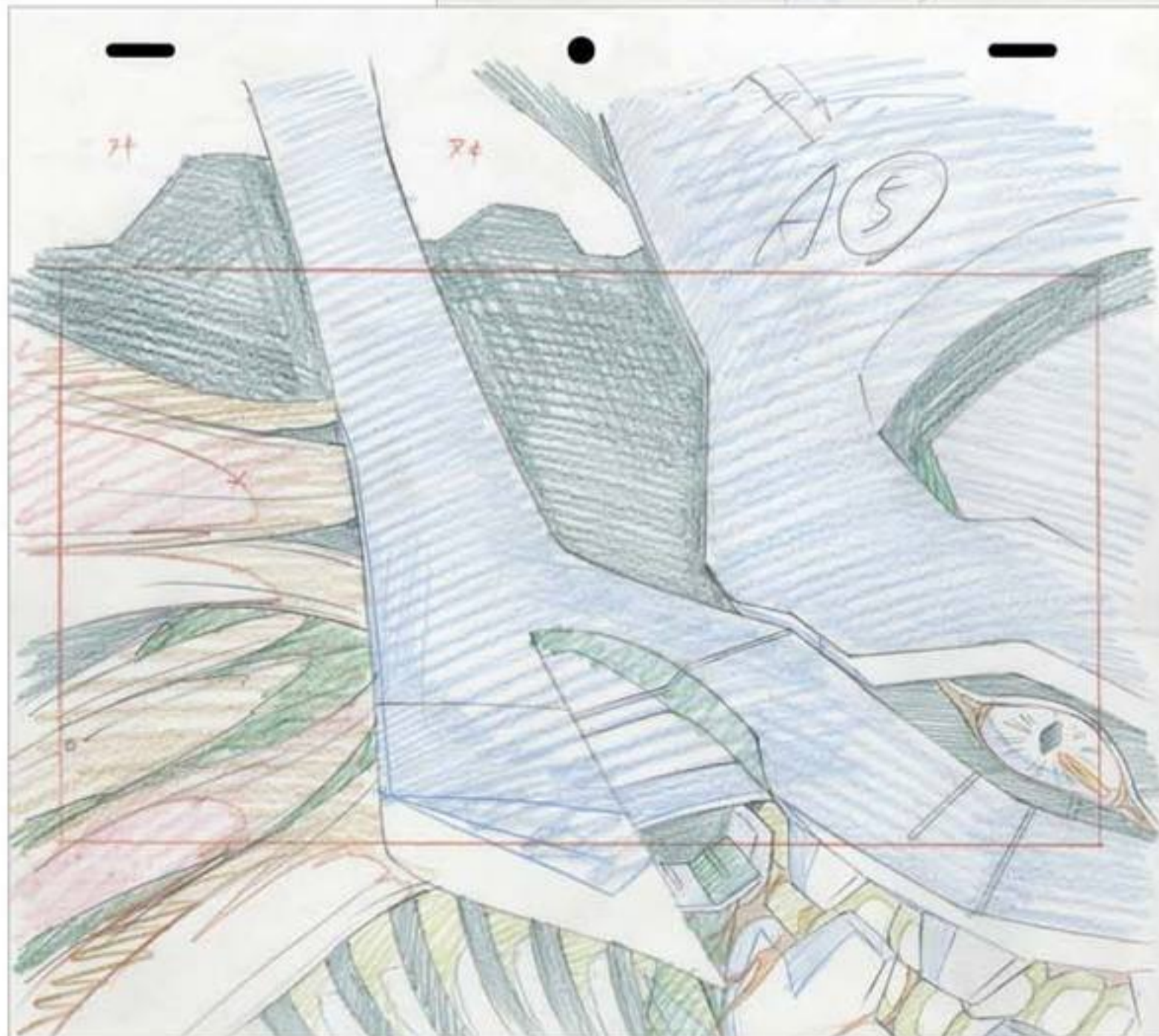
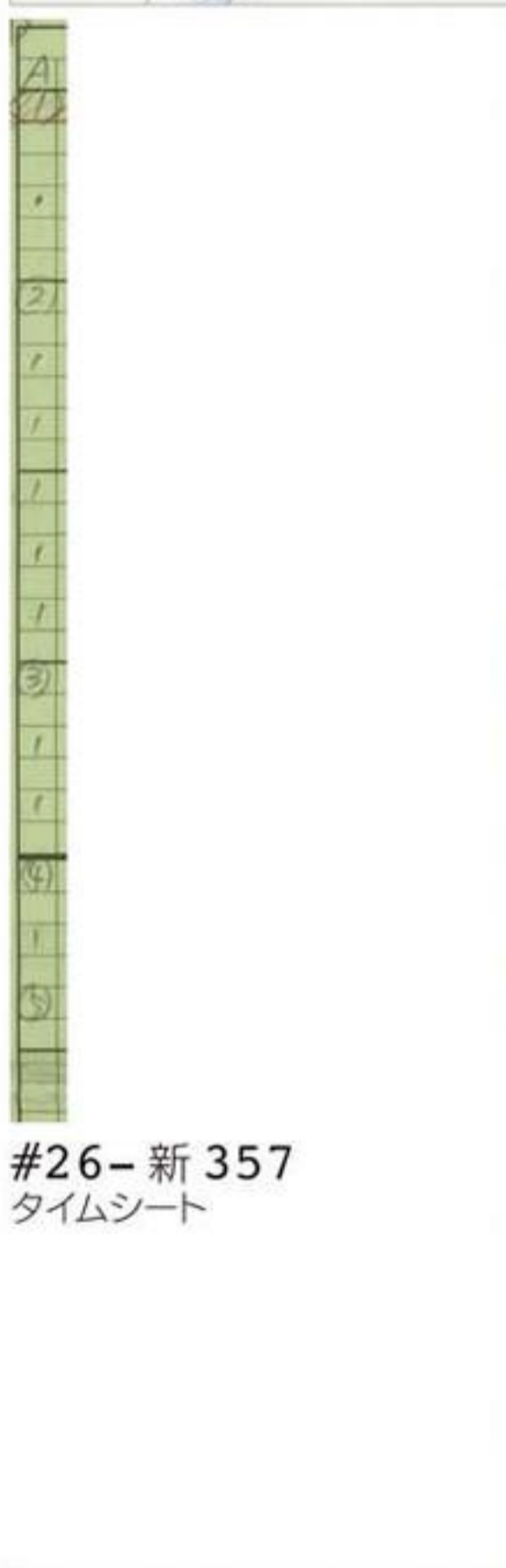

#26-新 357
タイムシート



#26-新 379
修正原画

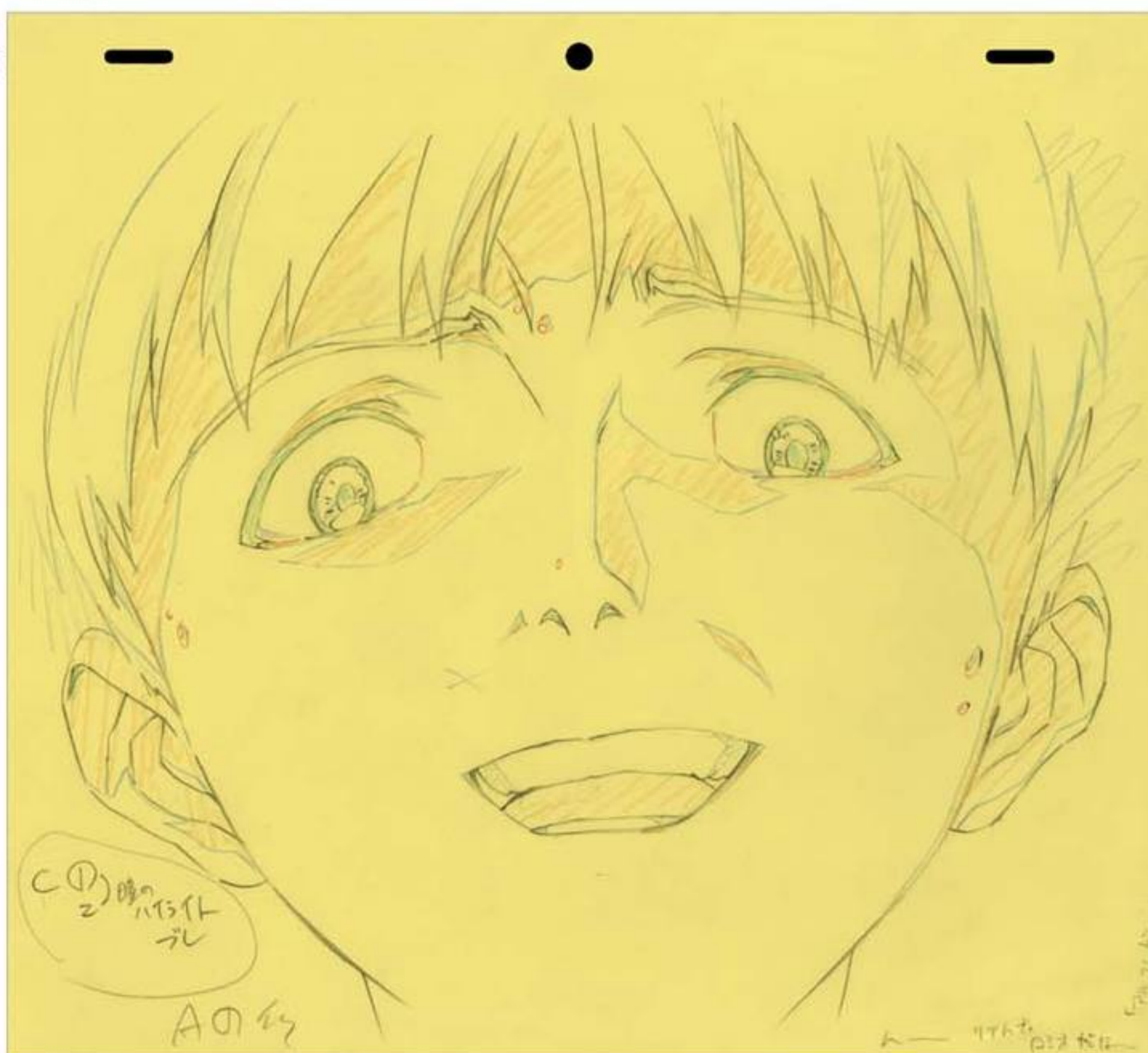



(B1) 修



B①

(B1)



(B2) 修



B②

(B)



(A1) 修

(12)



A④x

(12) の 半面

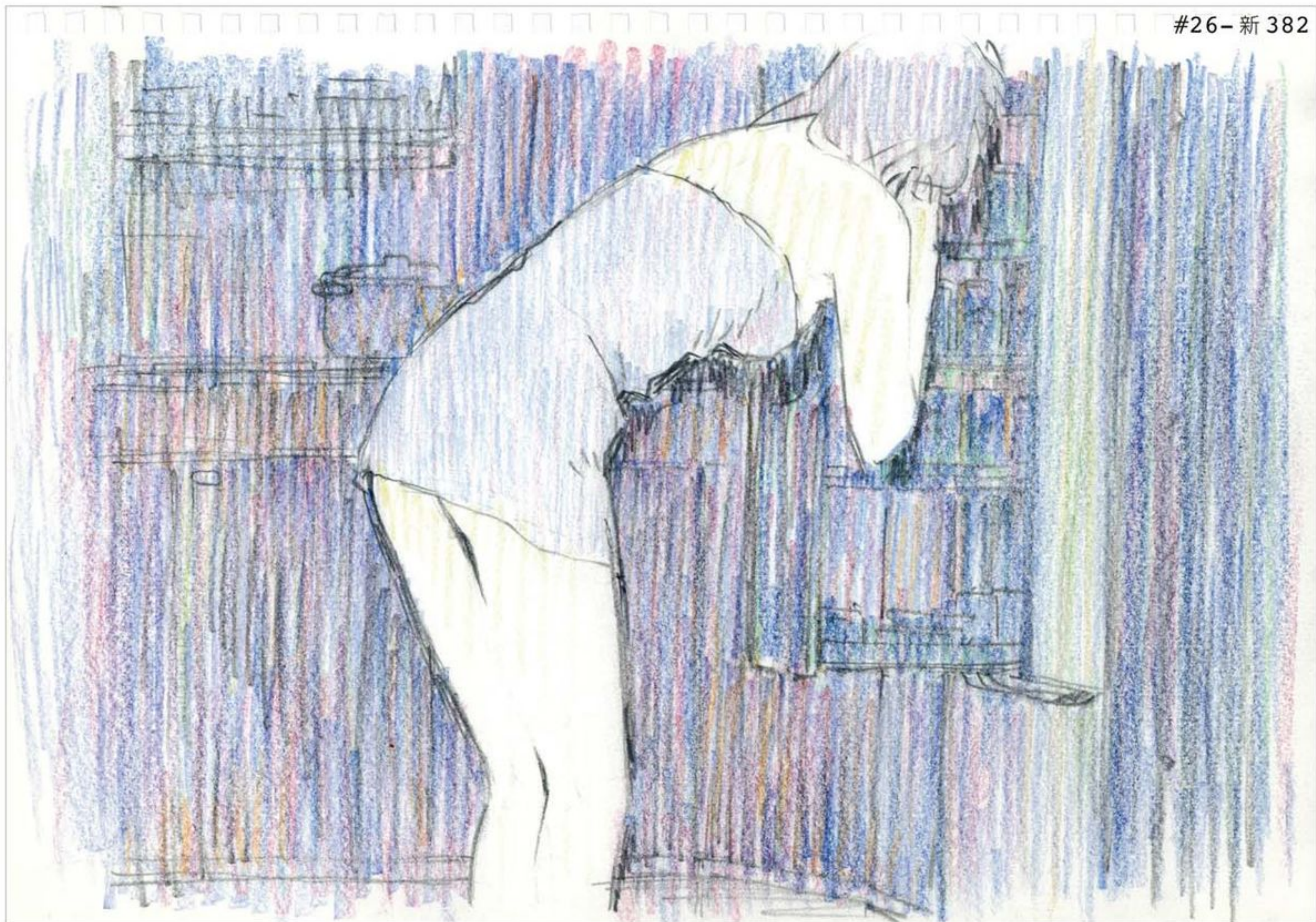

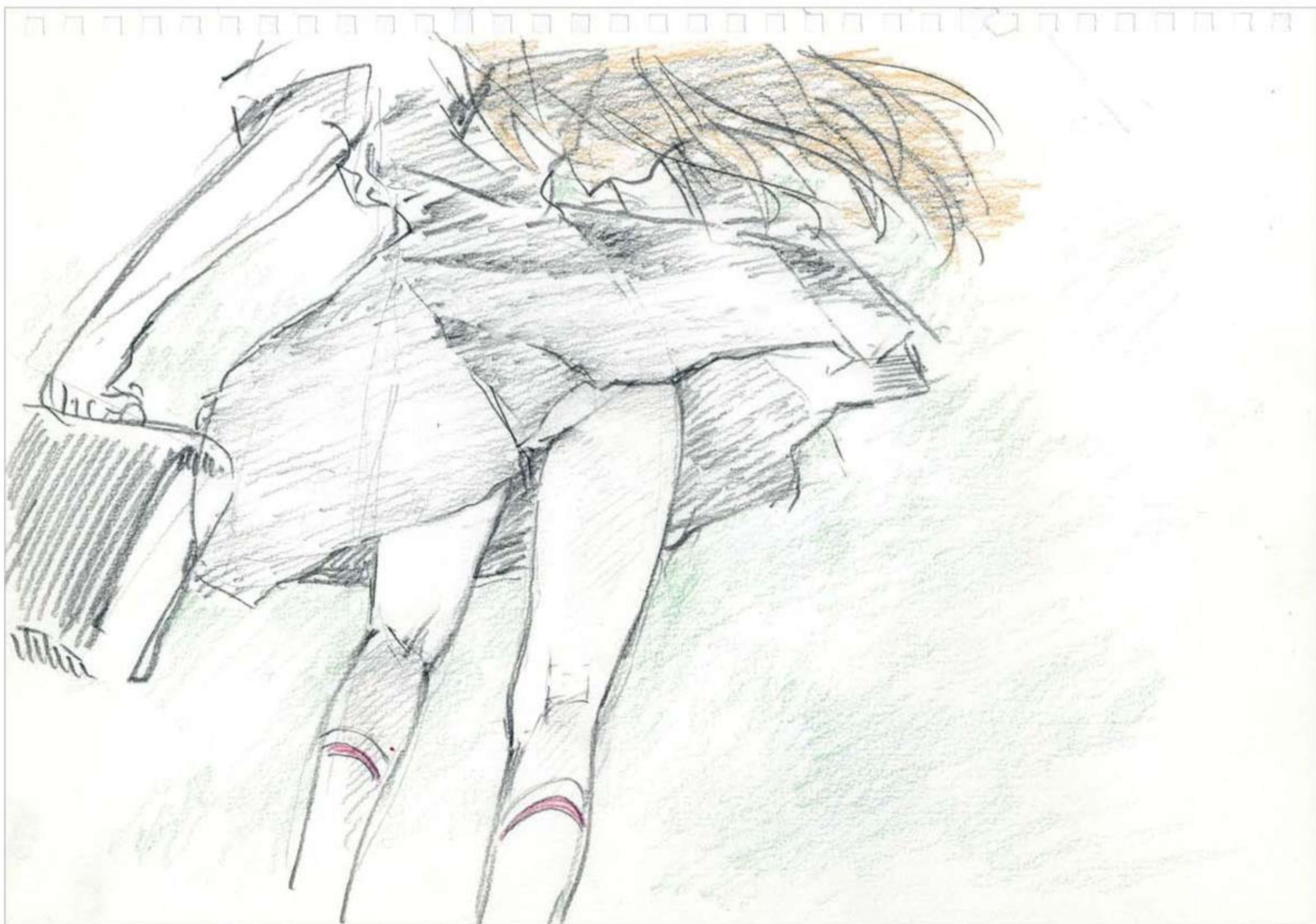

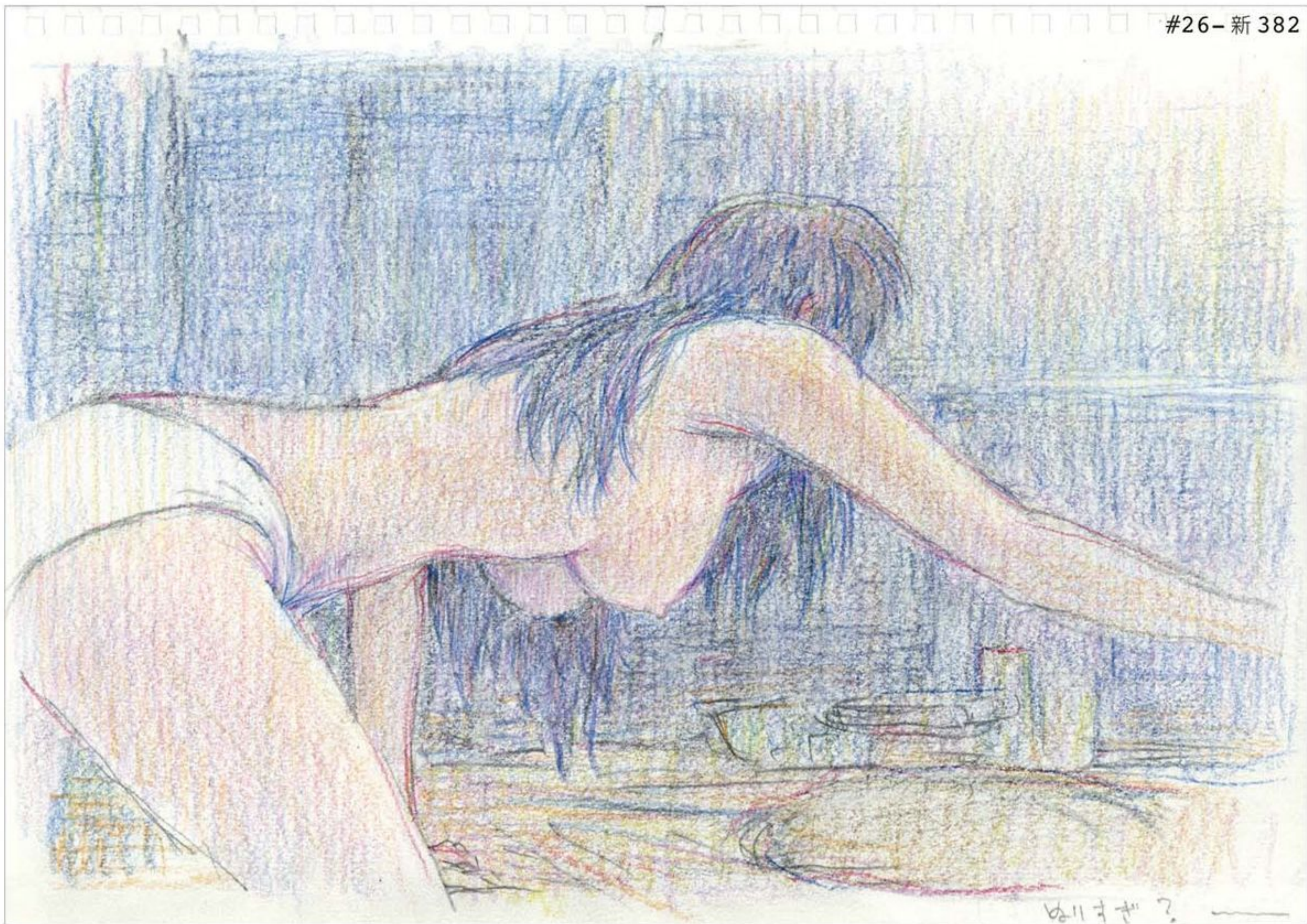

ゆいさき？

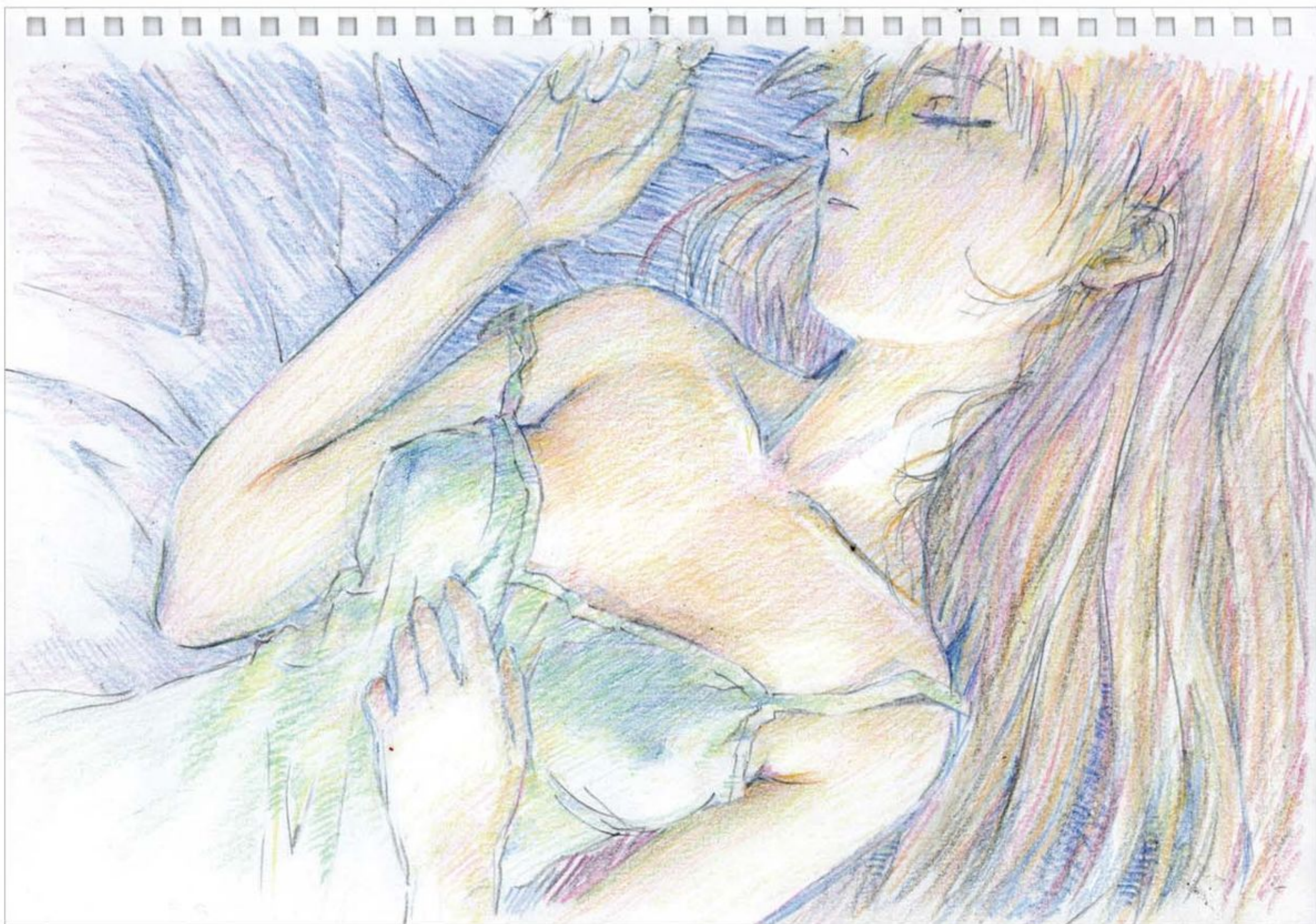

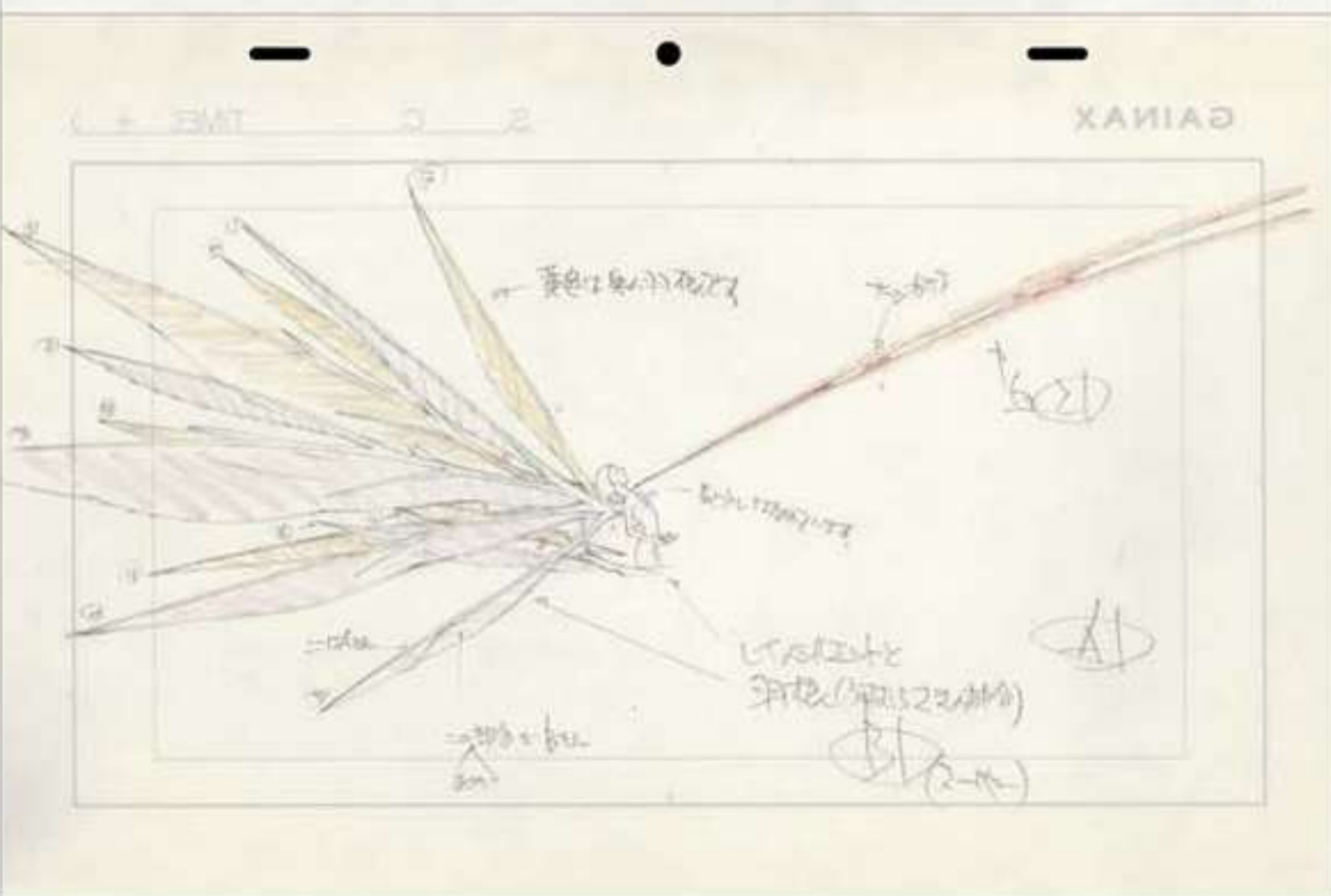
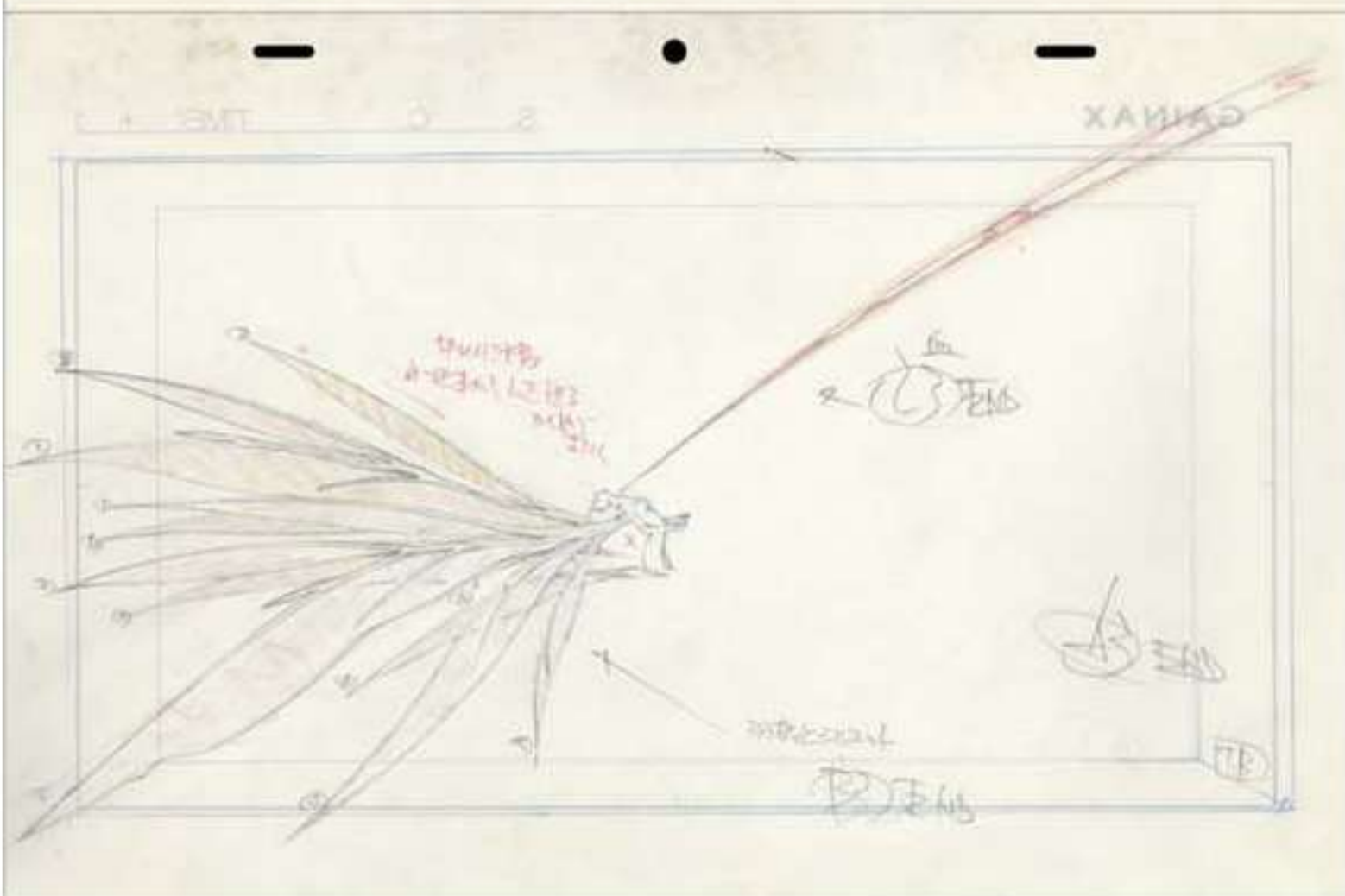
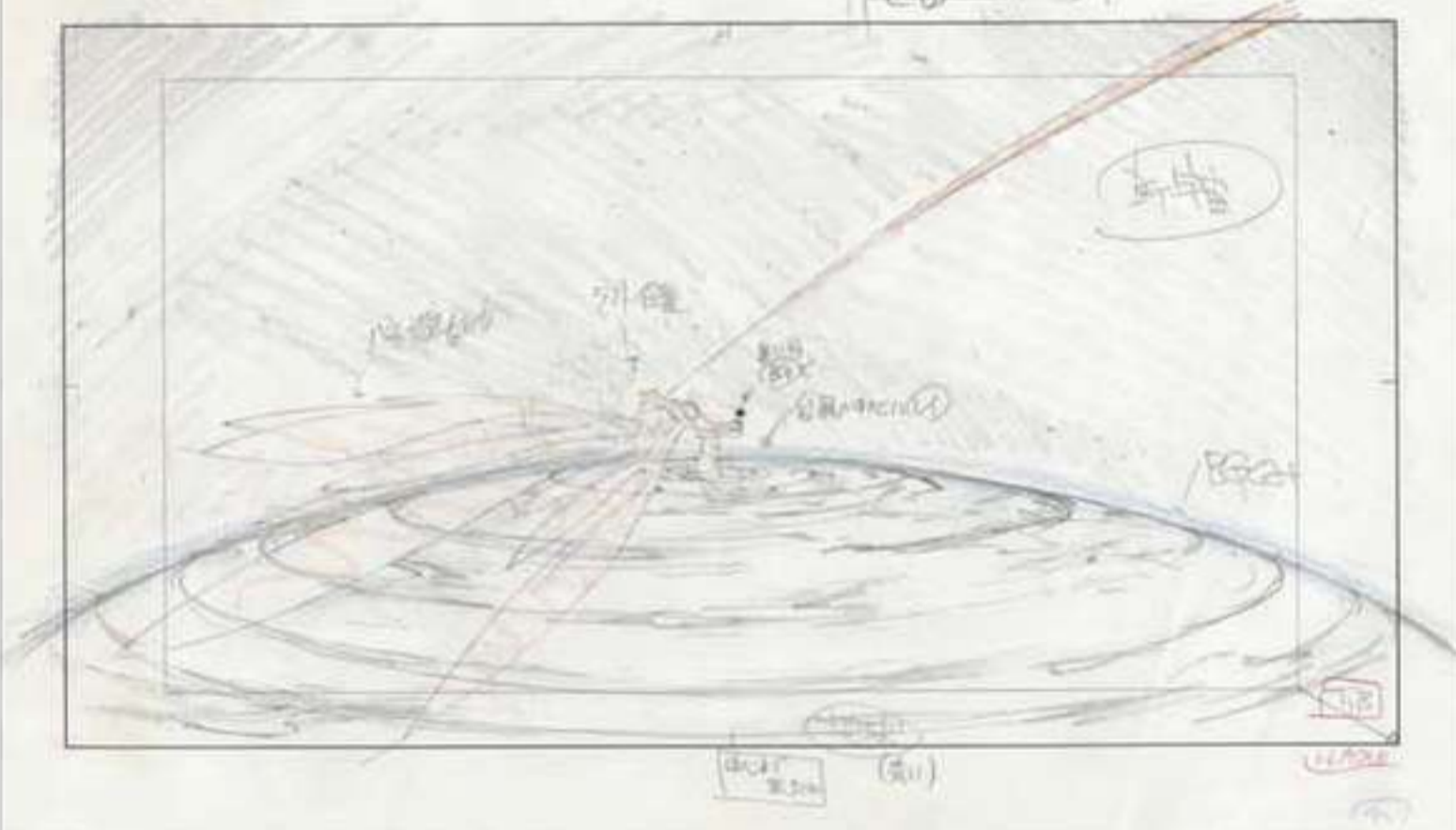
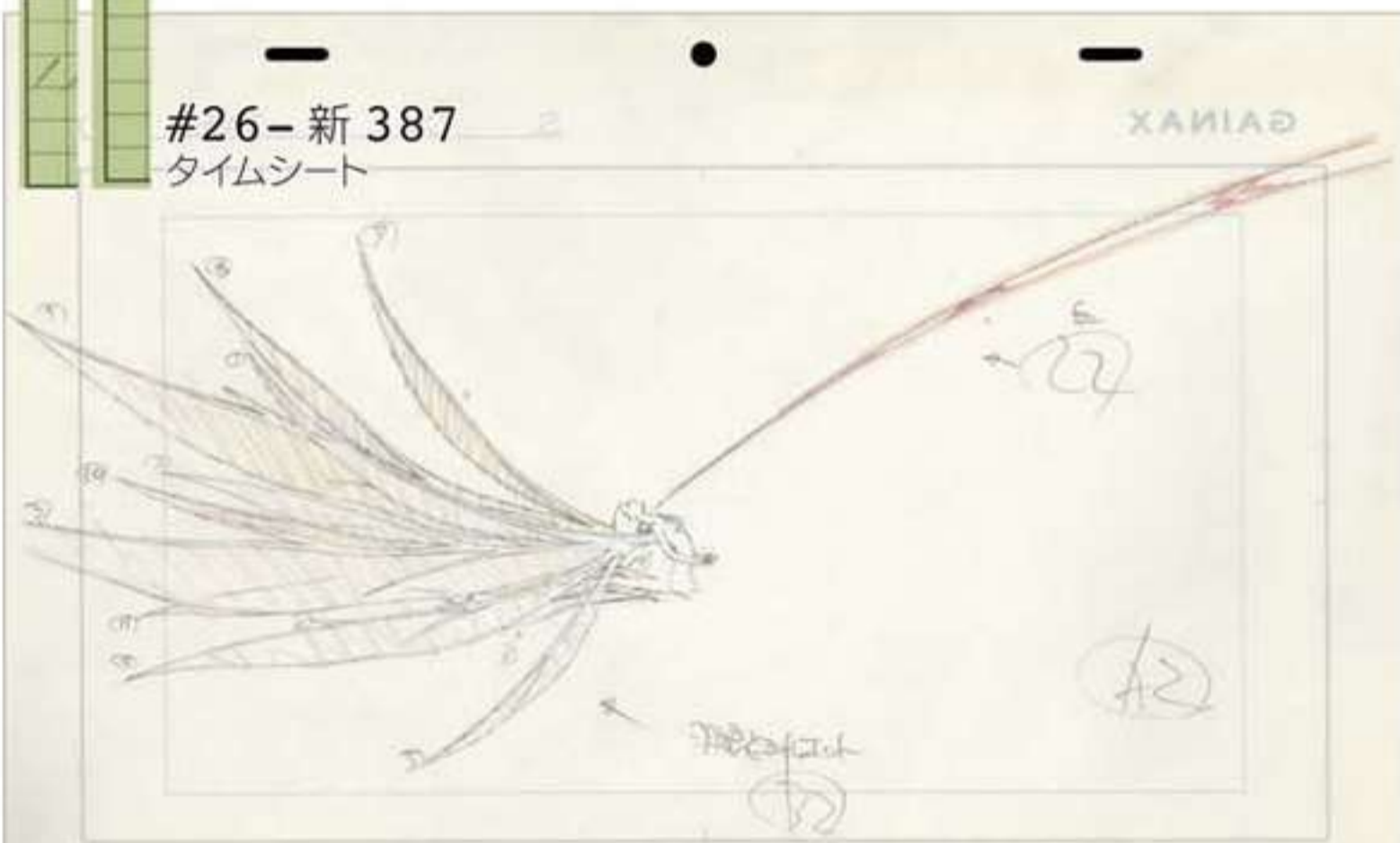

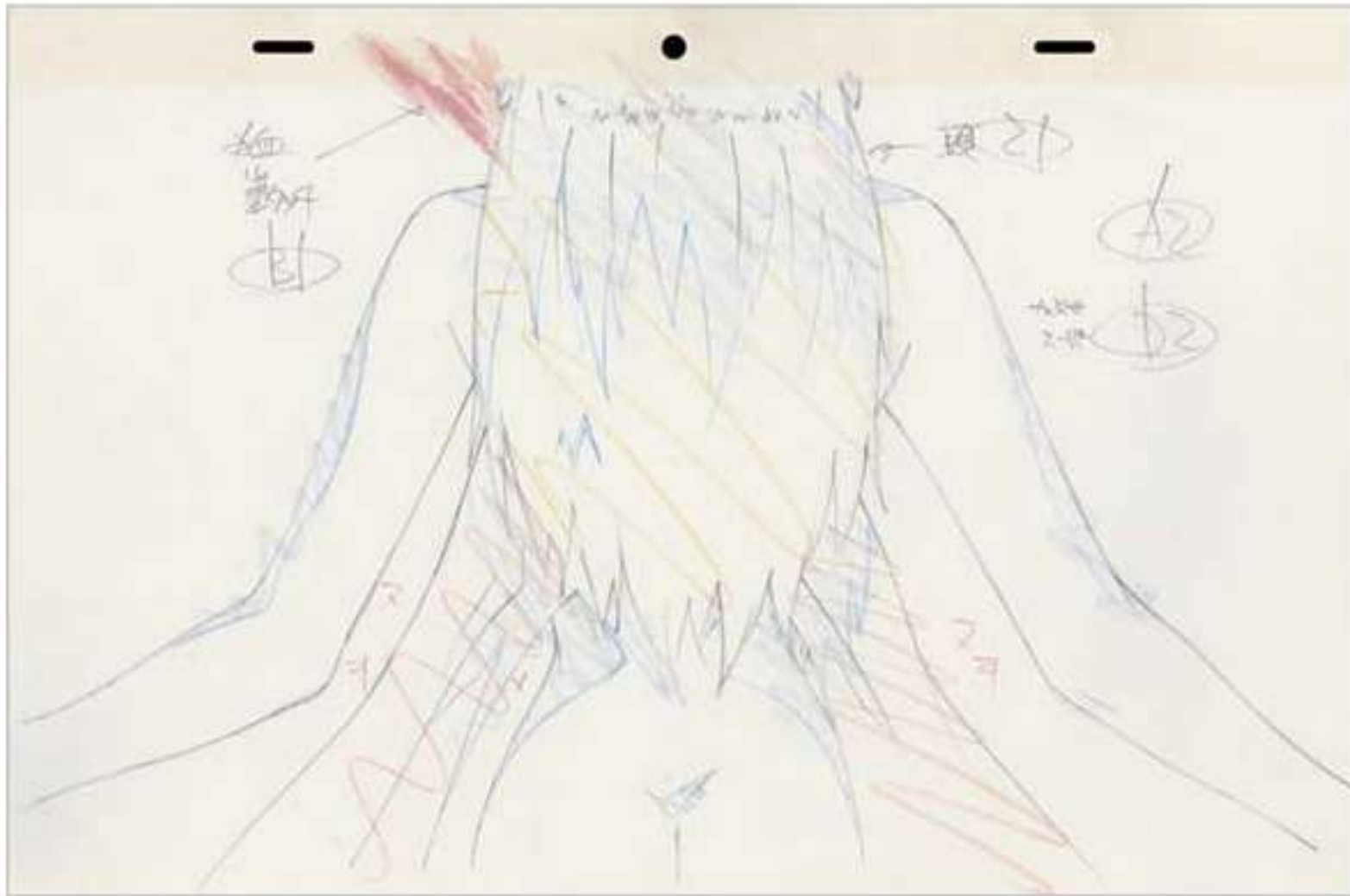

修正原画

#26-新388
タイムシート

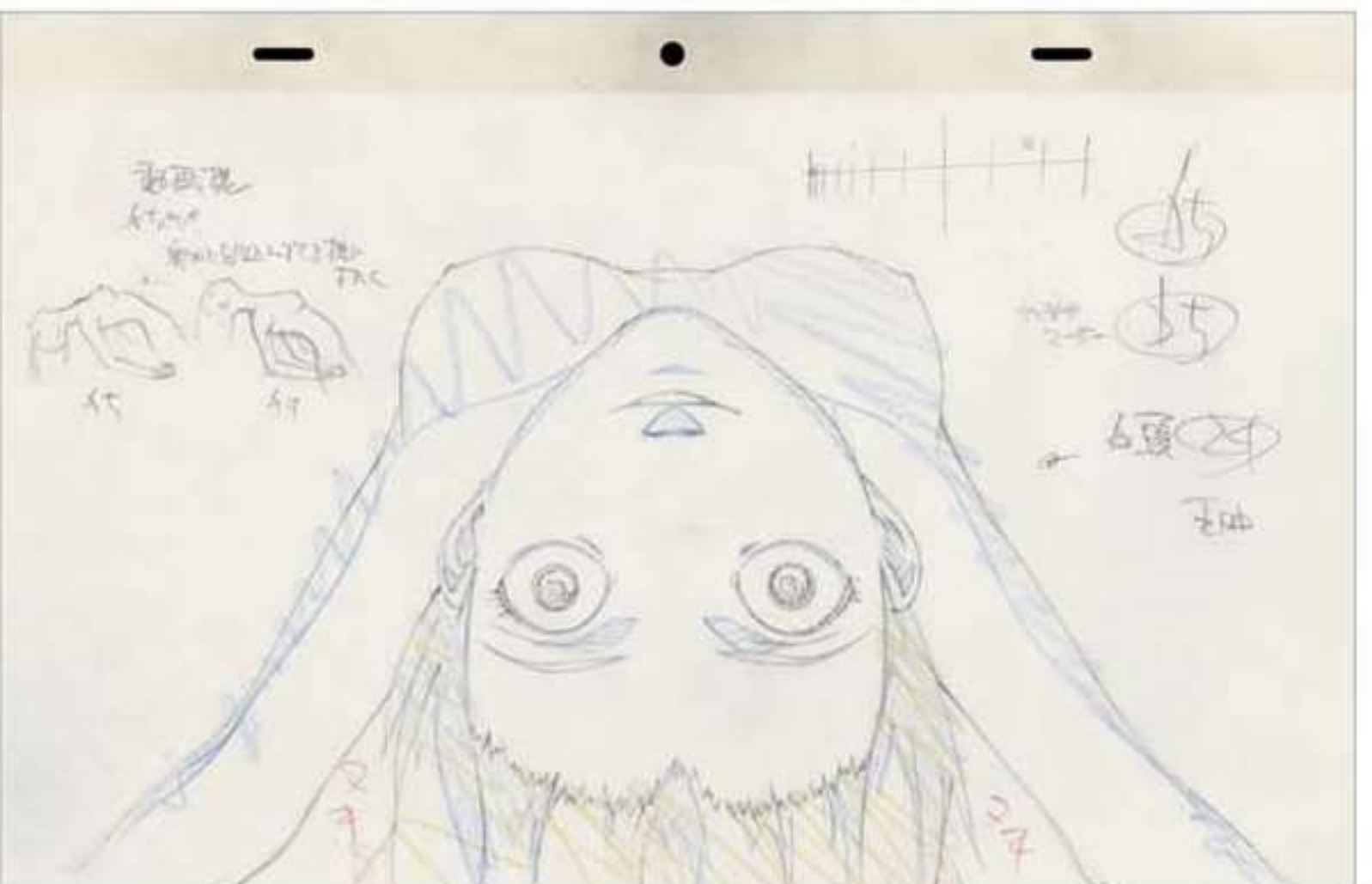
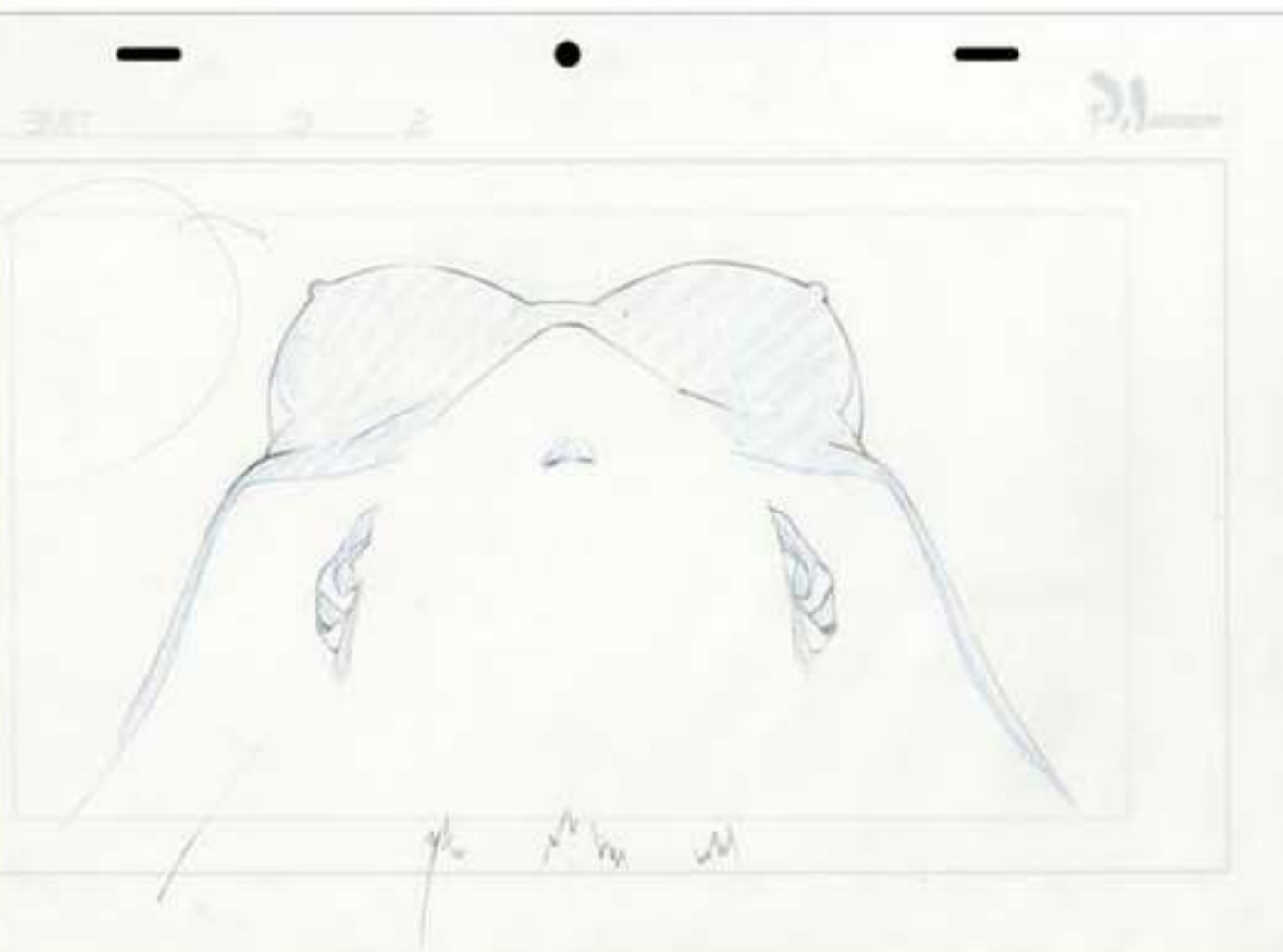
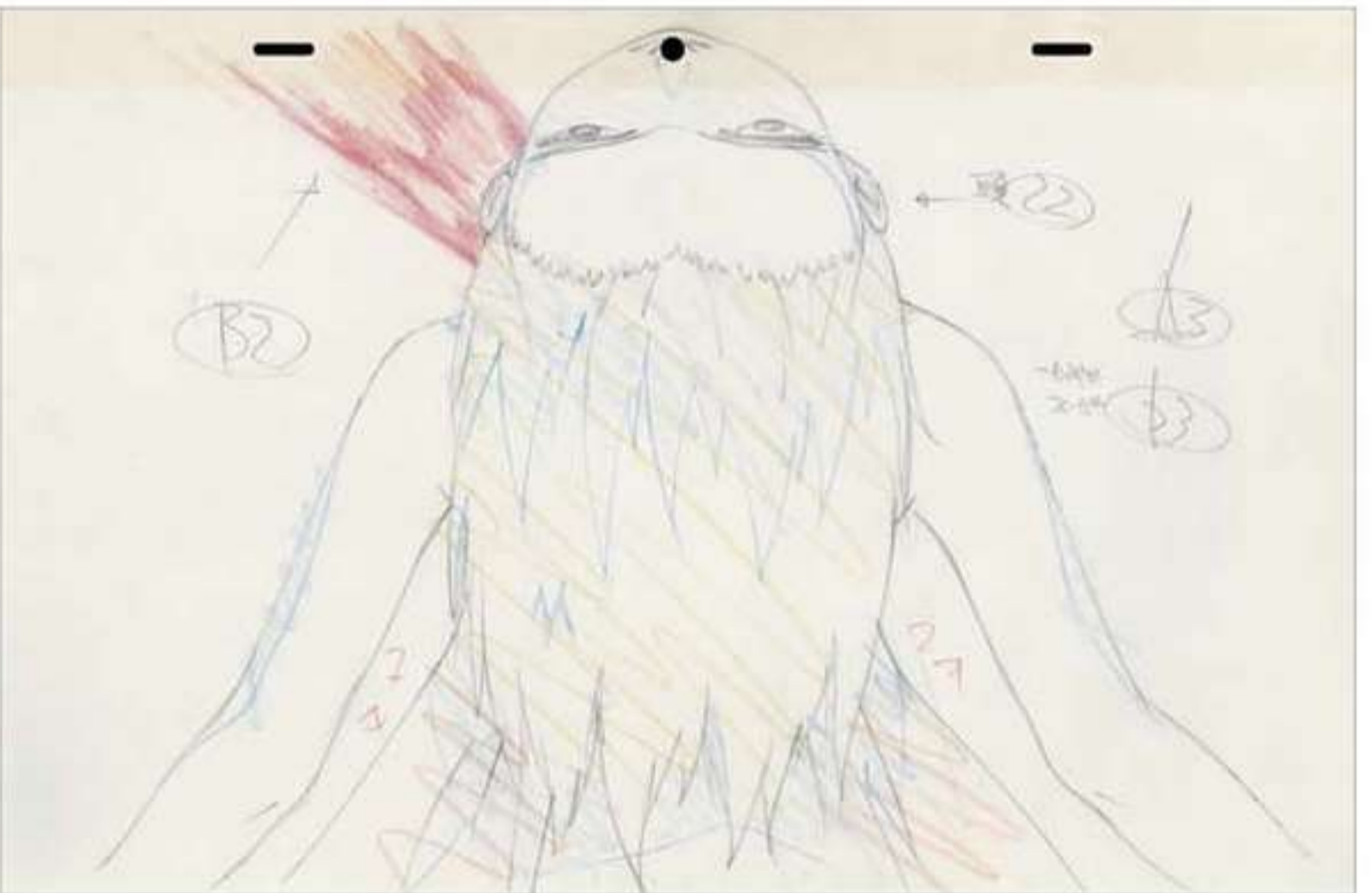
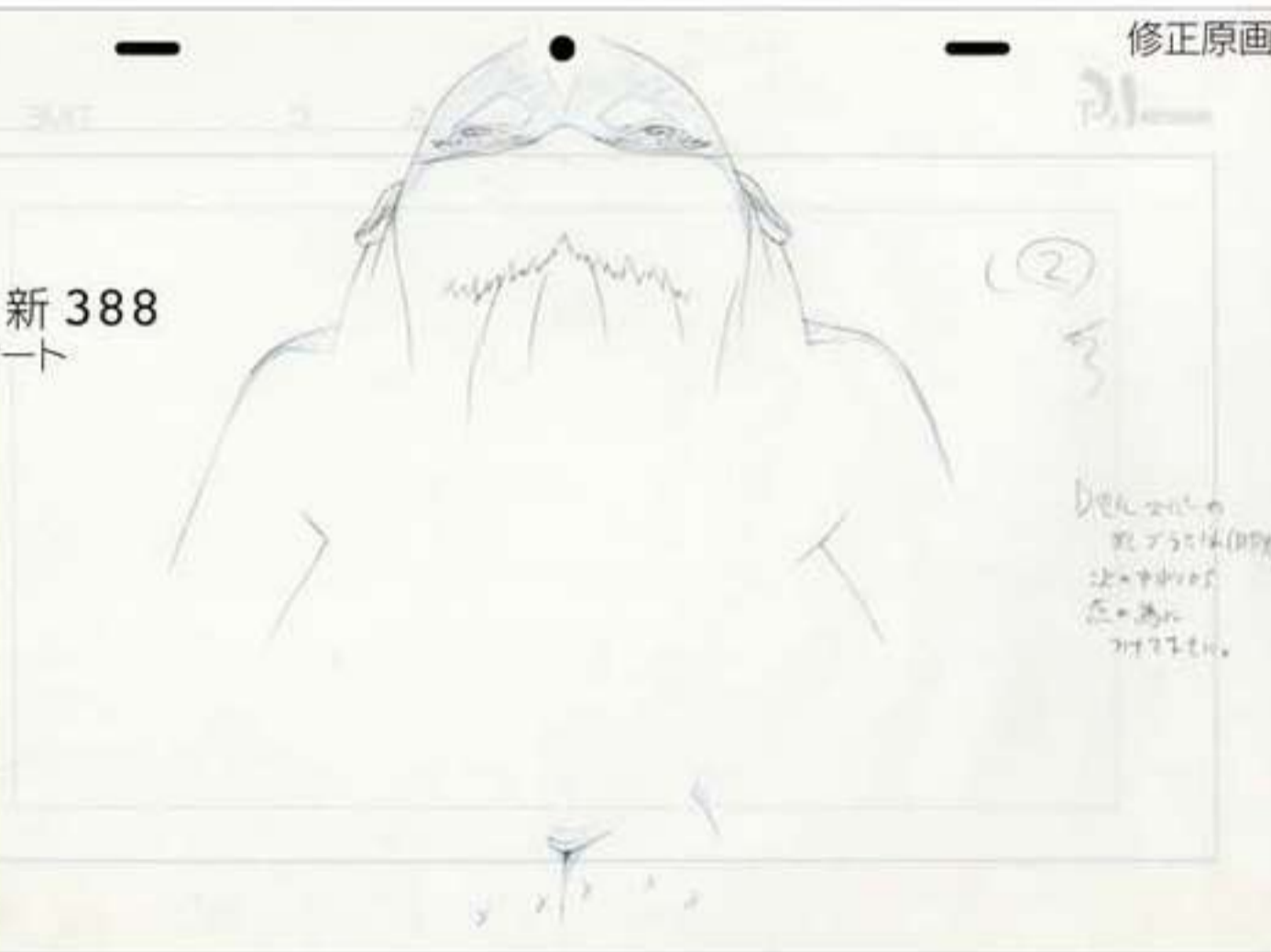



1910 740
2047 D12(3)
カサネの髪
C1
カサネ
Body

カサネの髪
この大きさで
1.4x1.4



PRODUCTION I.G EVA #26 C-415 S C TIME #26-新415 レイアウト

*画 | 2732 |
[DF]
[BG] 27
[月]



修正原画

DT
3
(B) 1/3



PRODUCTION I.G S C TIME

(D) (C)

CAUTION!
★動画サマへの輪の中は全てアタリ
に描いた色を色分けは
動画時のアタリ用です
動画には絶対トシ直して下され!!



修正原画

A1
1/3
カサネ
BD
2/3



#26-新416 S C

カサネ
BD
2/3
A0

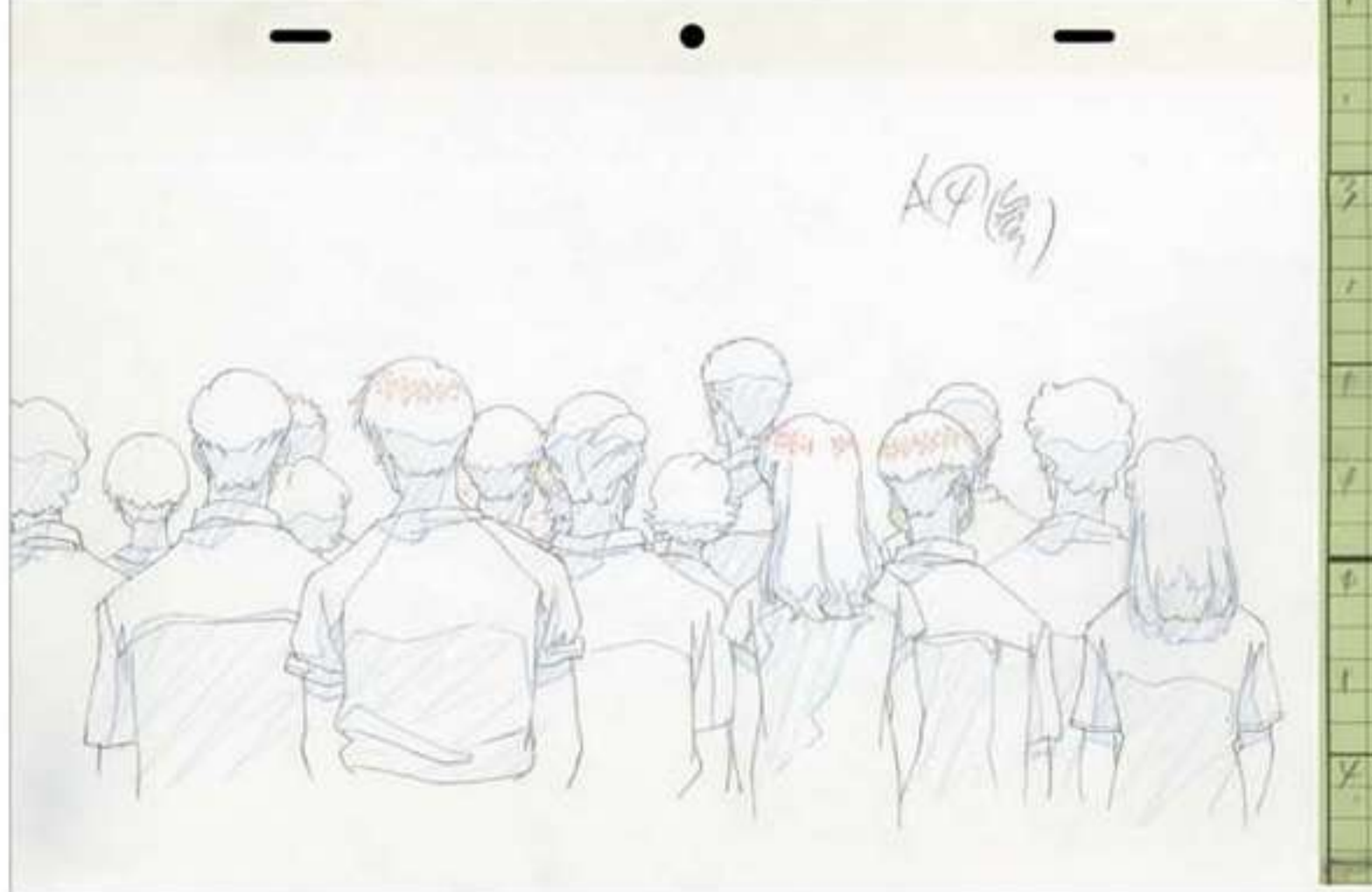

48	0
49	0
50	0
51	0
52	0
53	0
54	0
55	0
56	0
57	0
58	0
59	0
60	0
61	0
62	0
63	0
64	0
65	0
66	0
67	0
68	0
69	0
70	0
71	0
72	0
73	0
74	0
75	0
76	0
77	0
78	0
79	0
80	0
81	0
82	0
83	0
84	0
85	0
86	0
87	0
88	0
89	0
90	0
91	0
92	0
93	0
94	0
95	0
96	0
97	0
98	0
99	0
100	0

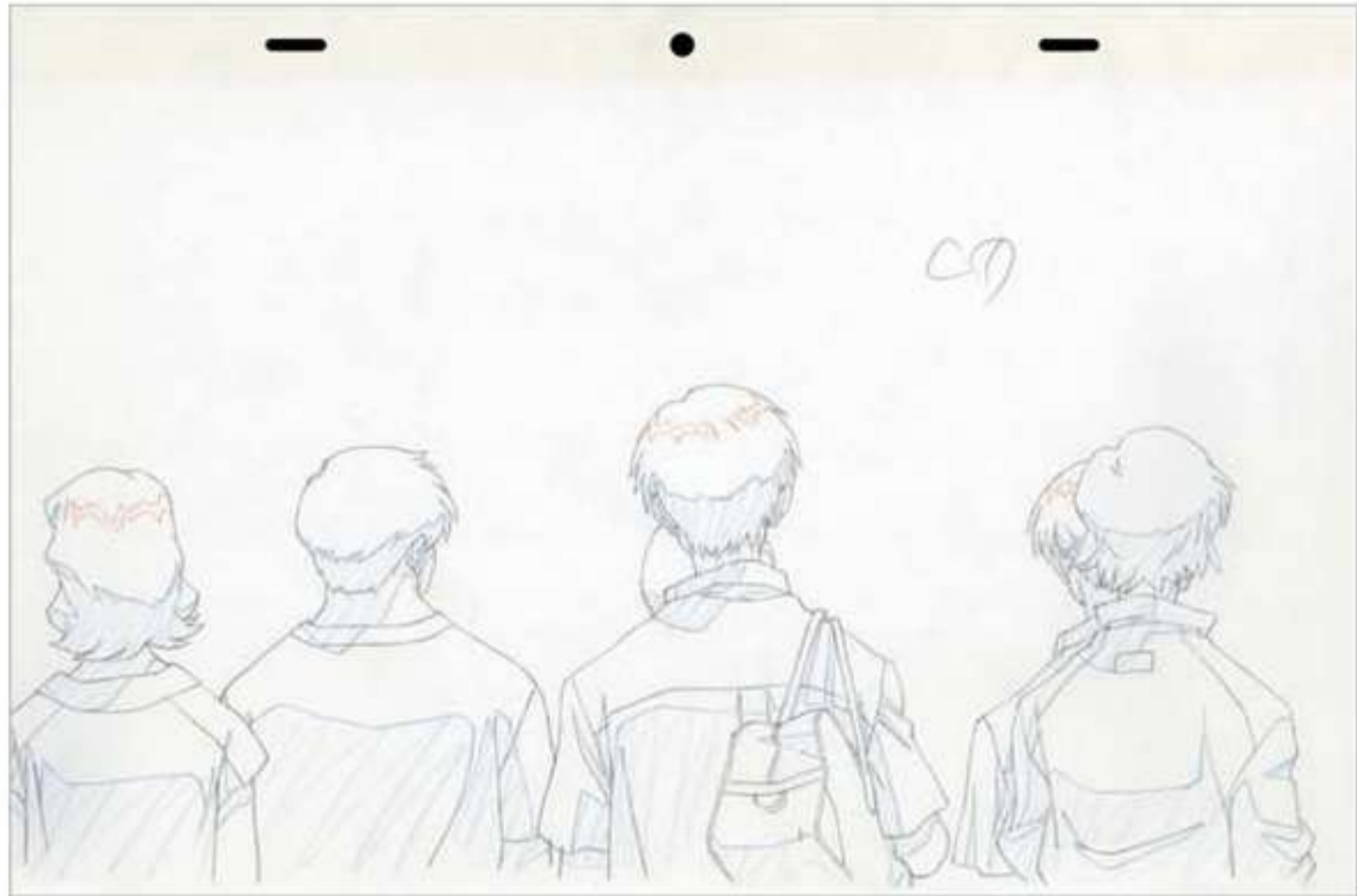

(B1)



(B1)にかきこみ



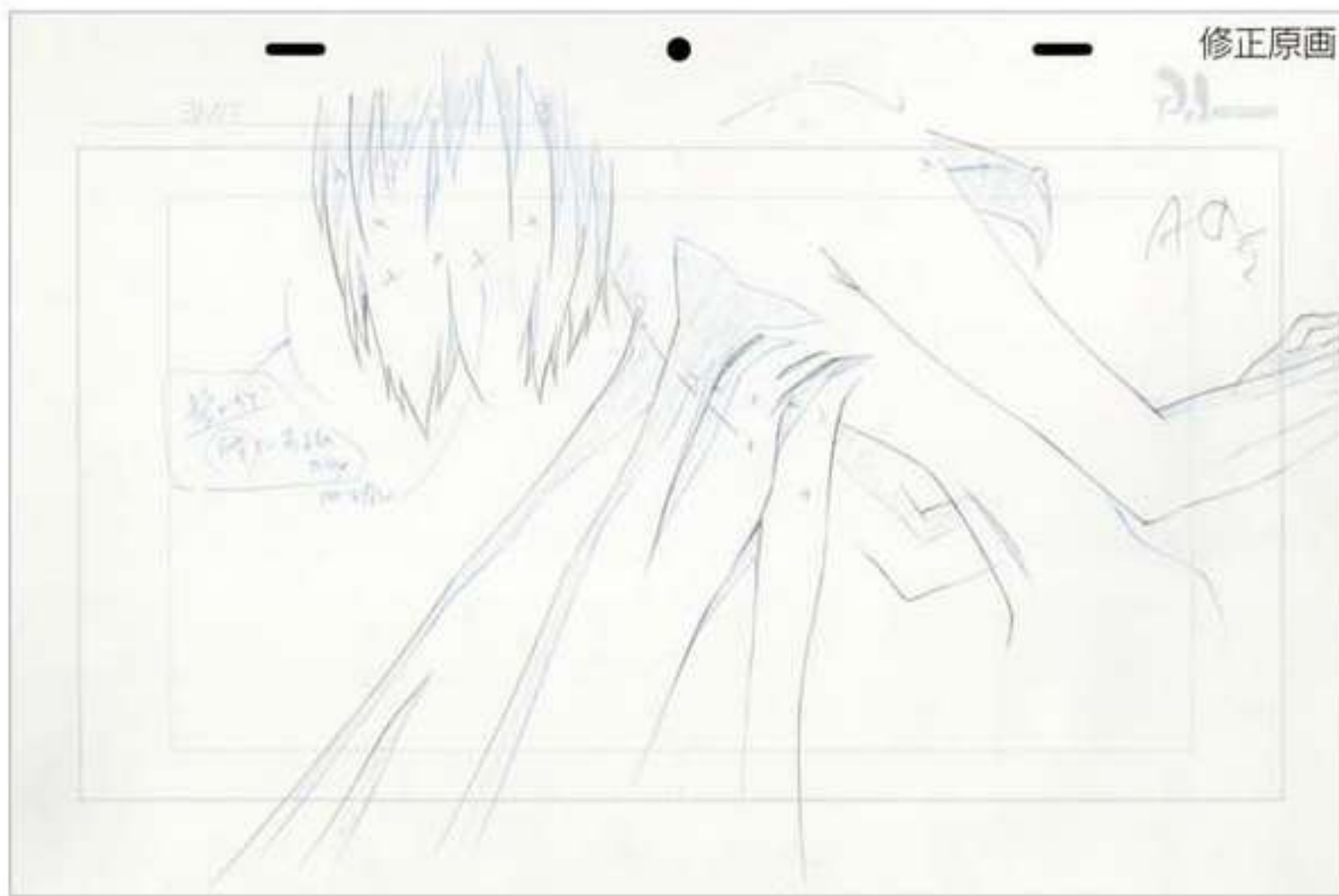

A	A	A	A
1	1	1	1
2	2	2	2
3	3	3	3
4	4	4	4
5	5	5	5
6	6	6	6
7	7	7	7
8	8	8	8
9	9	9	9
10	10	10	10
11	11	11	11
12	12	12	12
13	13	13	13
14	14	14	14
15	15	15	15
16	16	16	16
17	17	17	17
18	18	18	18
19	19	19	19
20	20	20	20

#26-新431
レイアウト

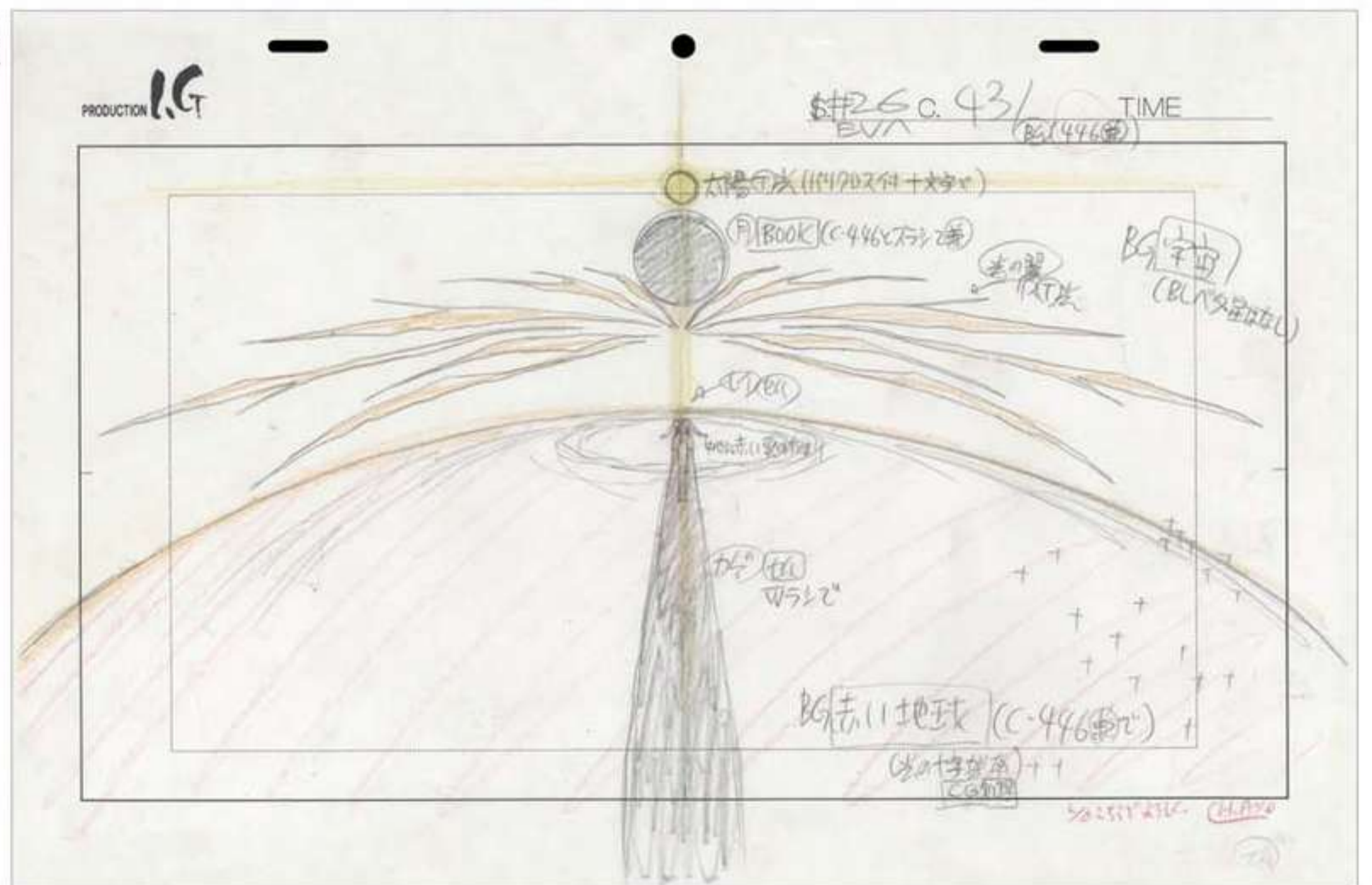

#26-新422
タイムシート

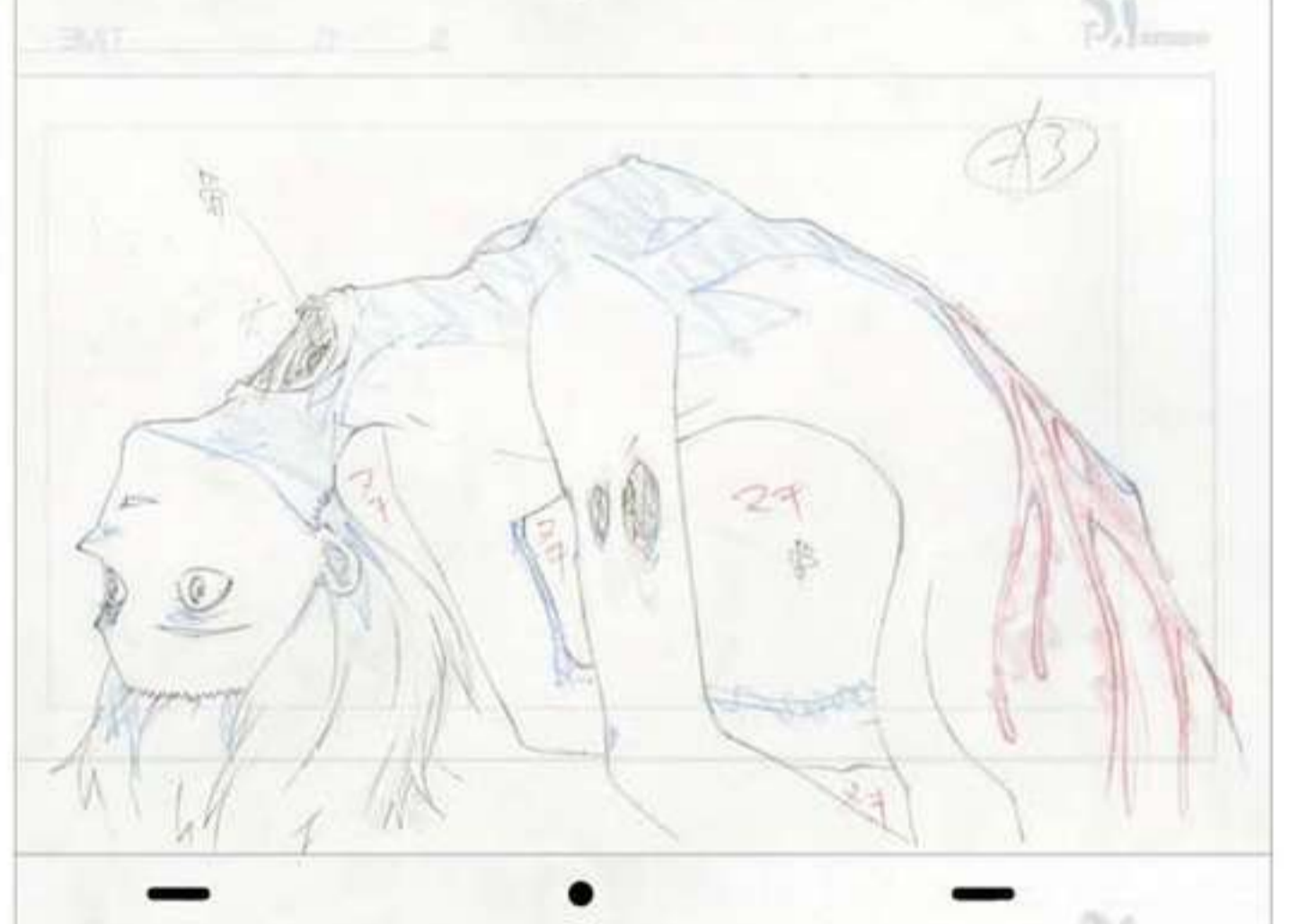
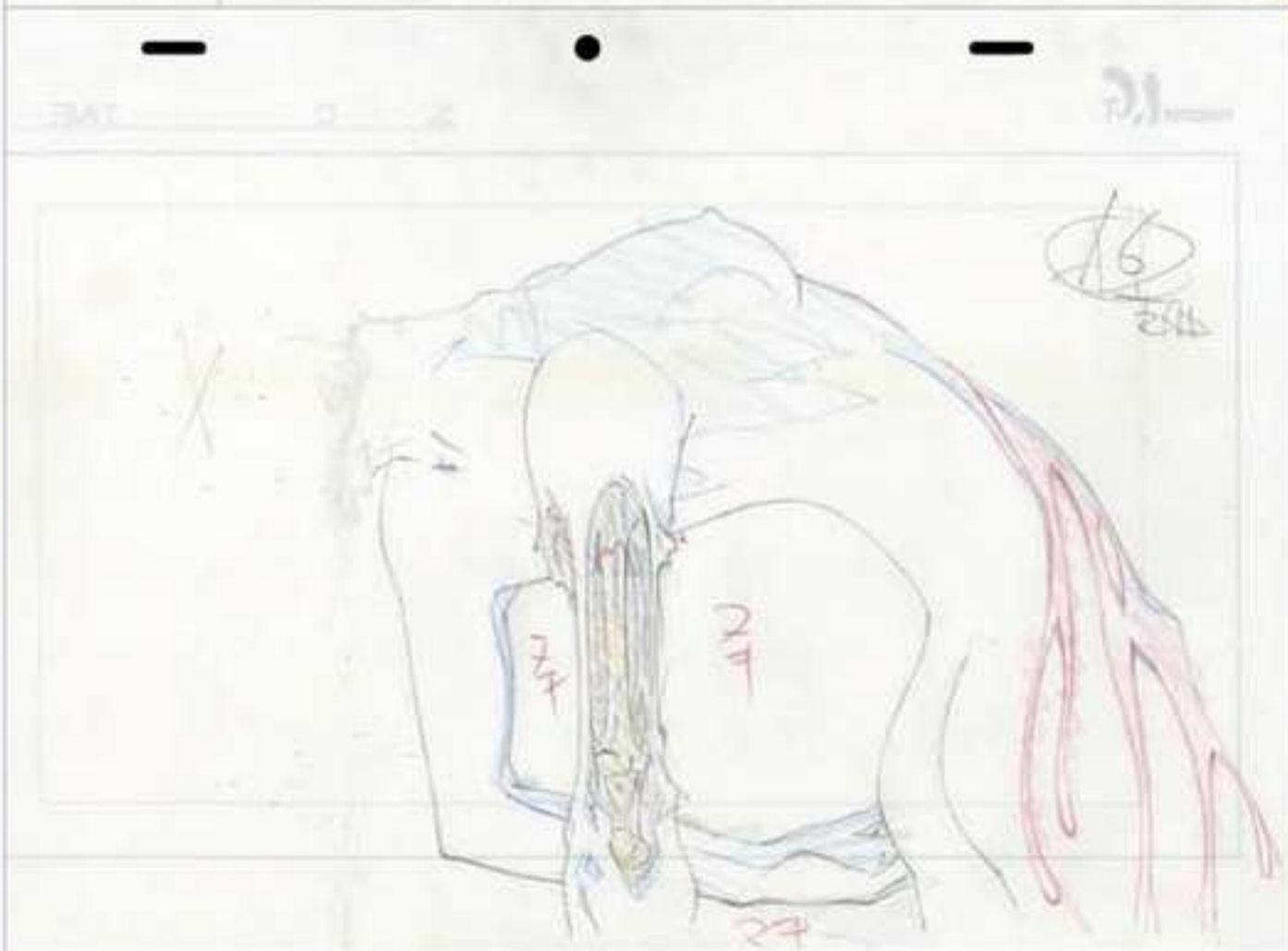
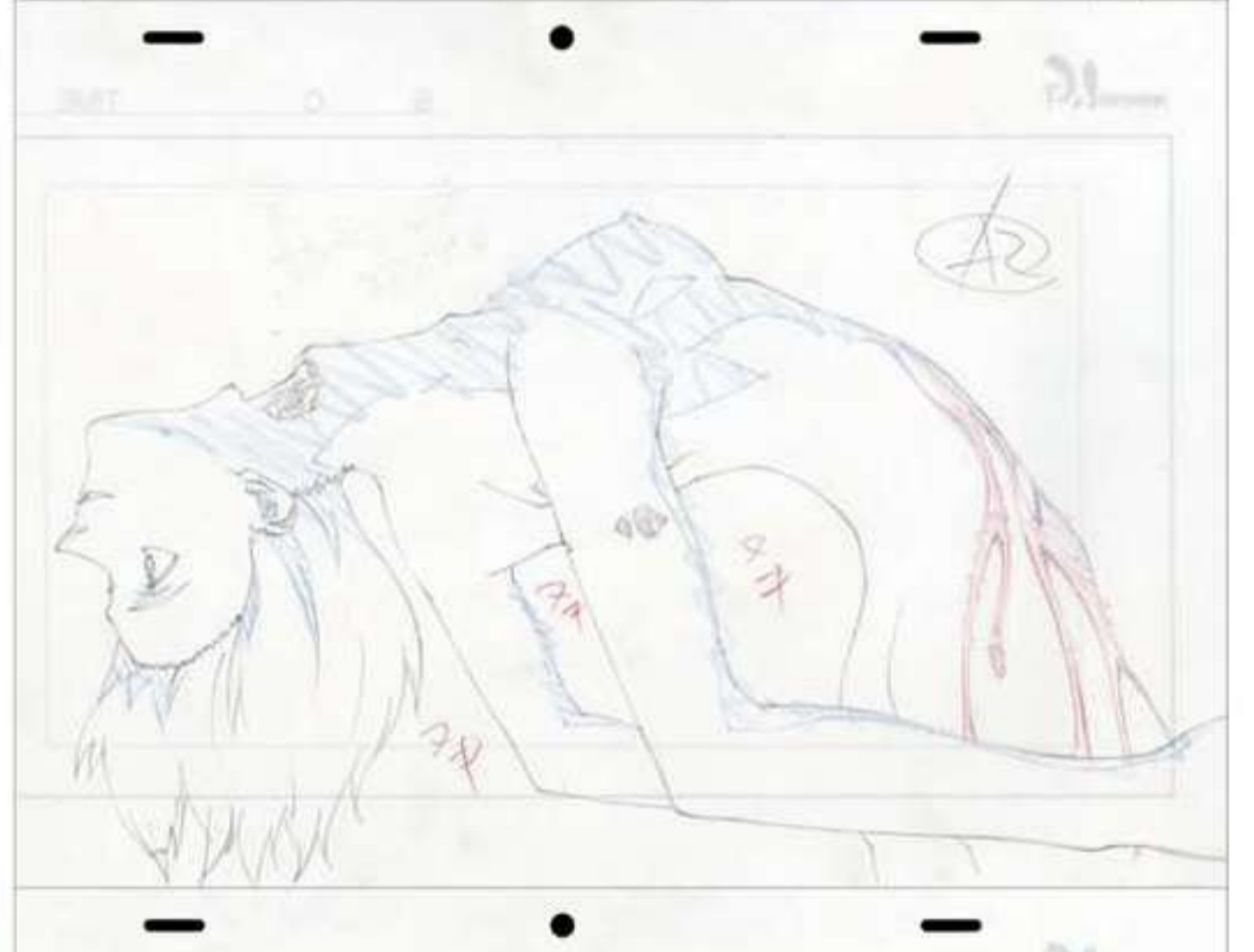
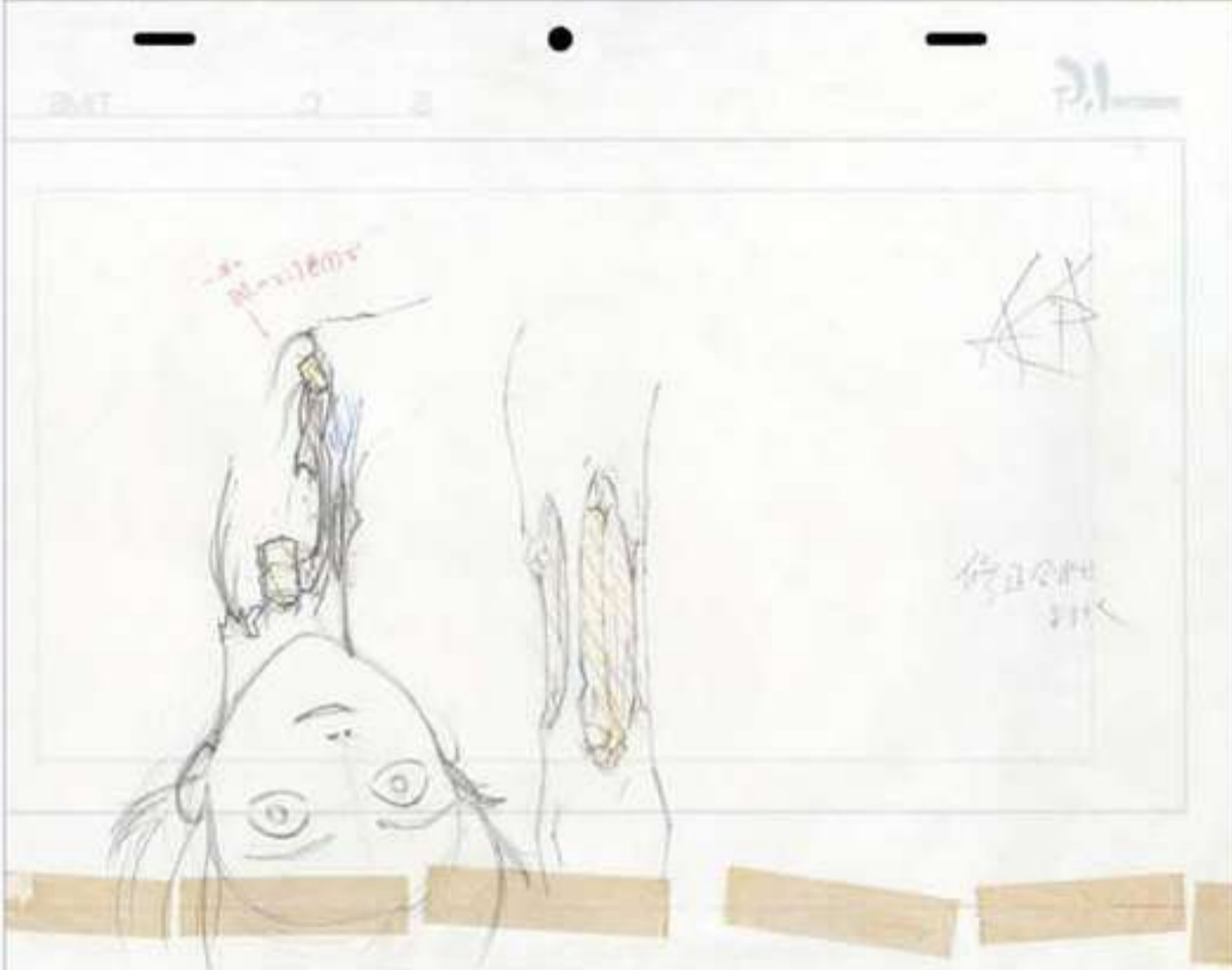
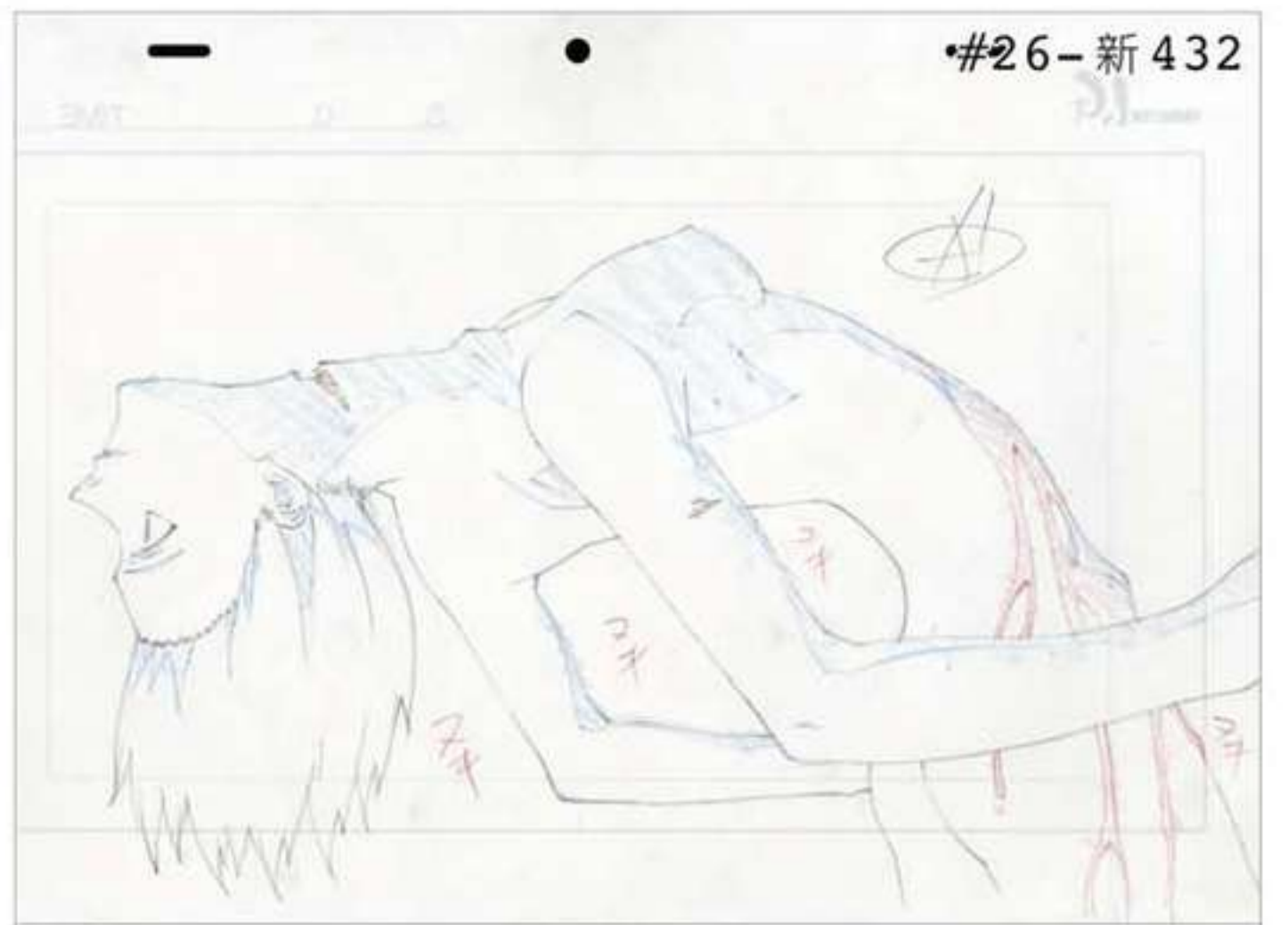
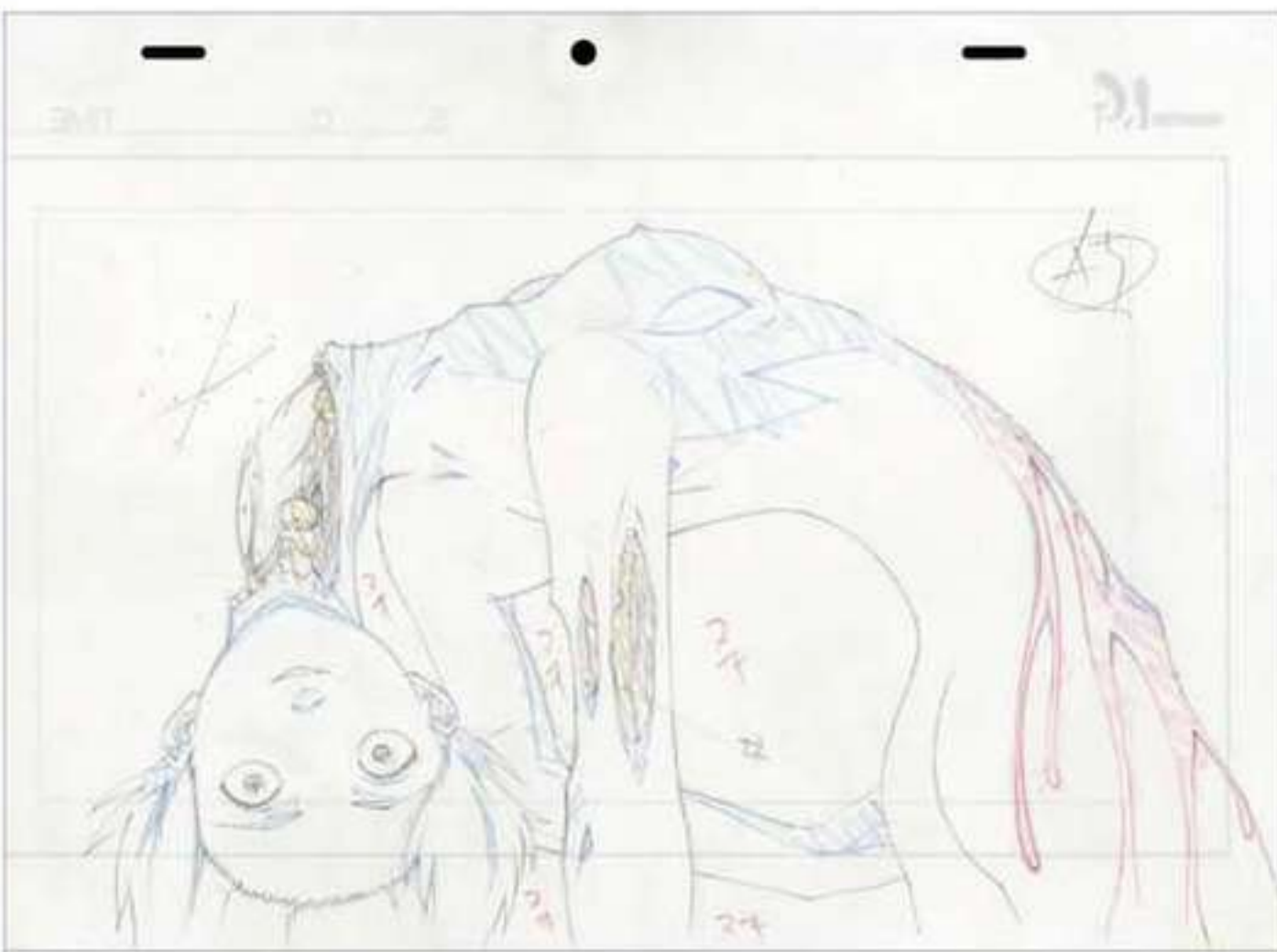

#26-新 449
修正原画



#26-新 448
修正原画



レイアウト修正



#26-新 460
レイアウト

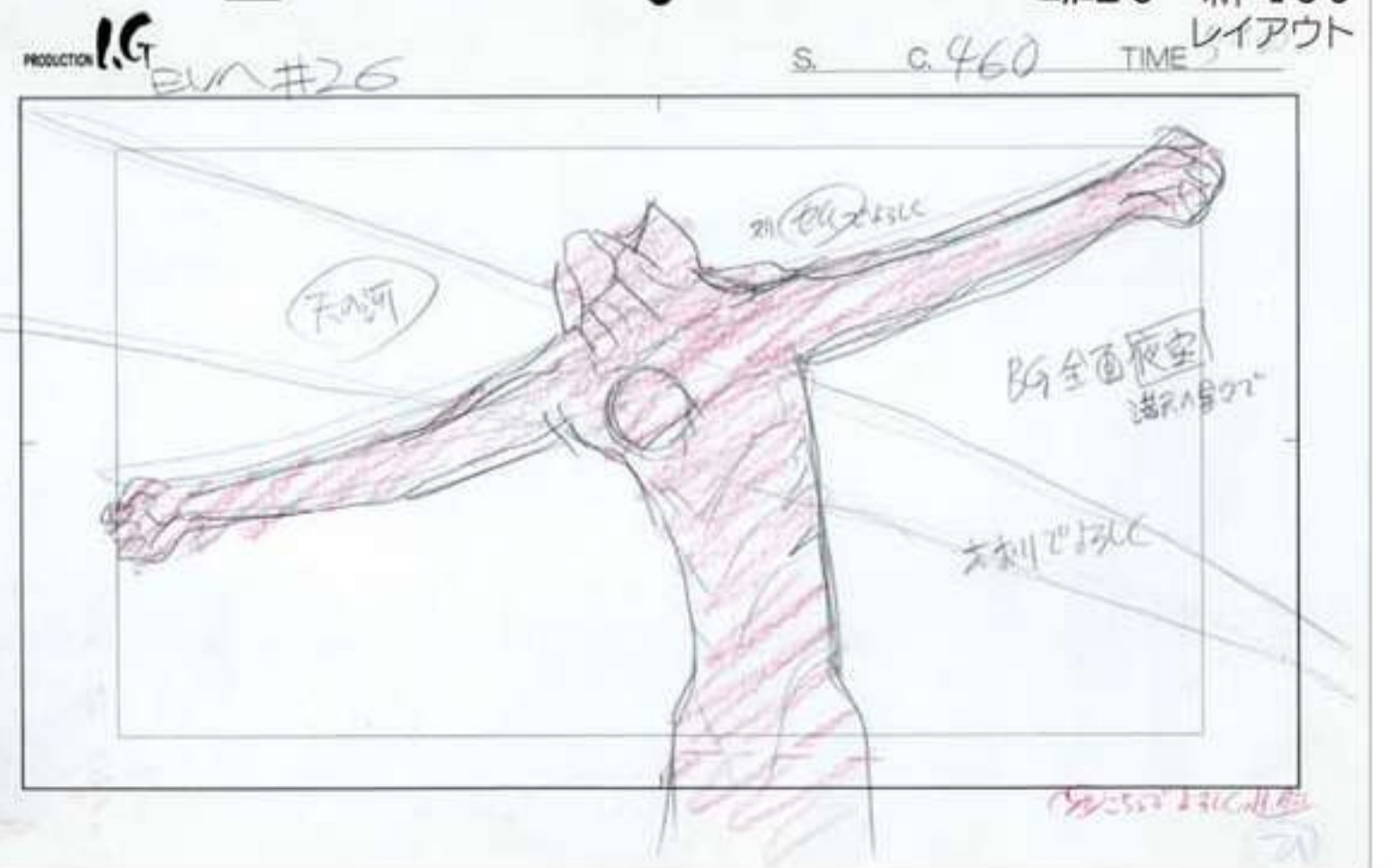

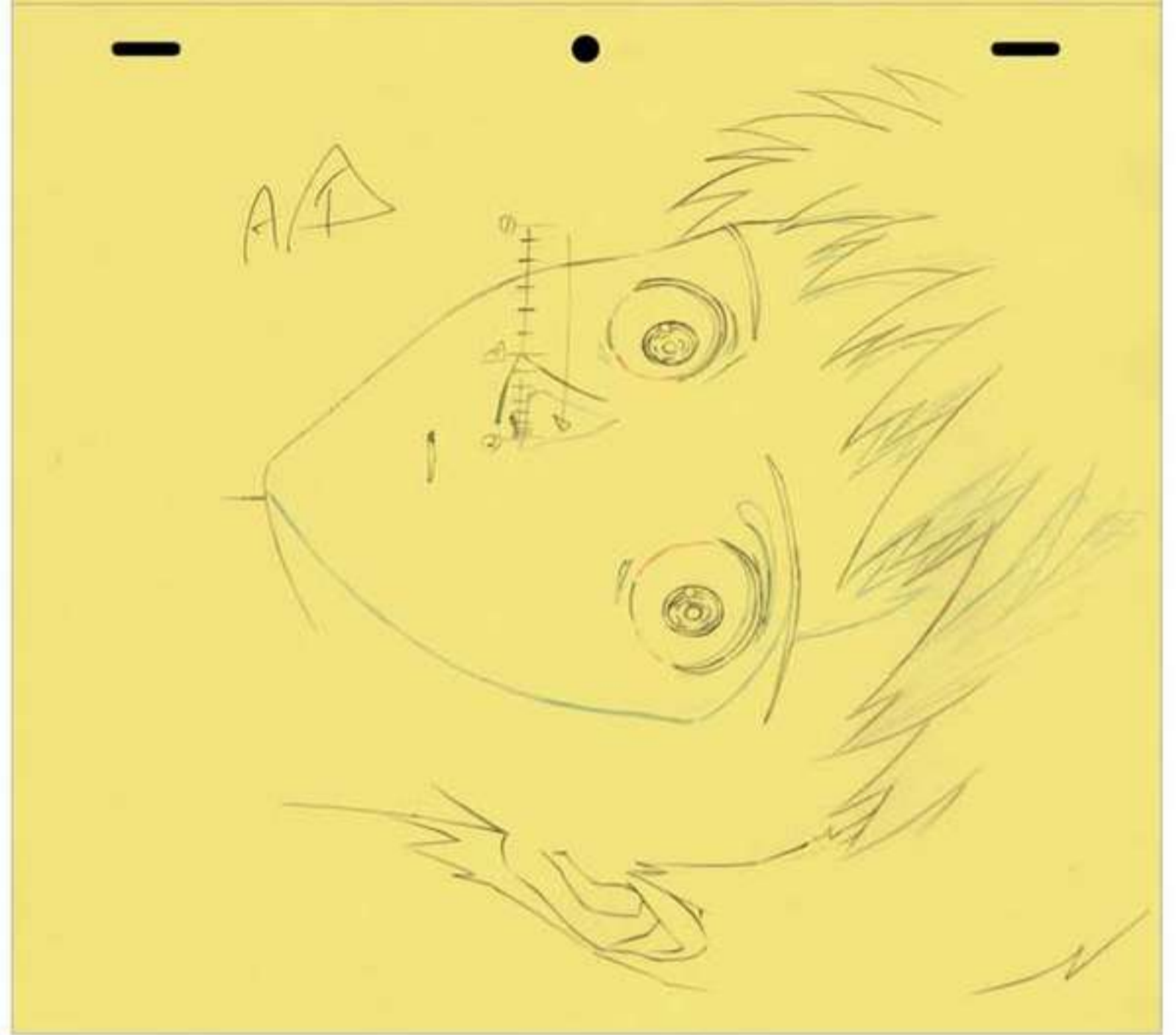
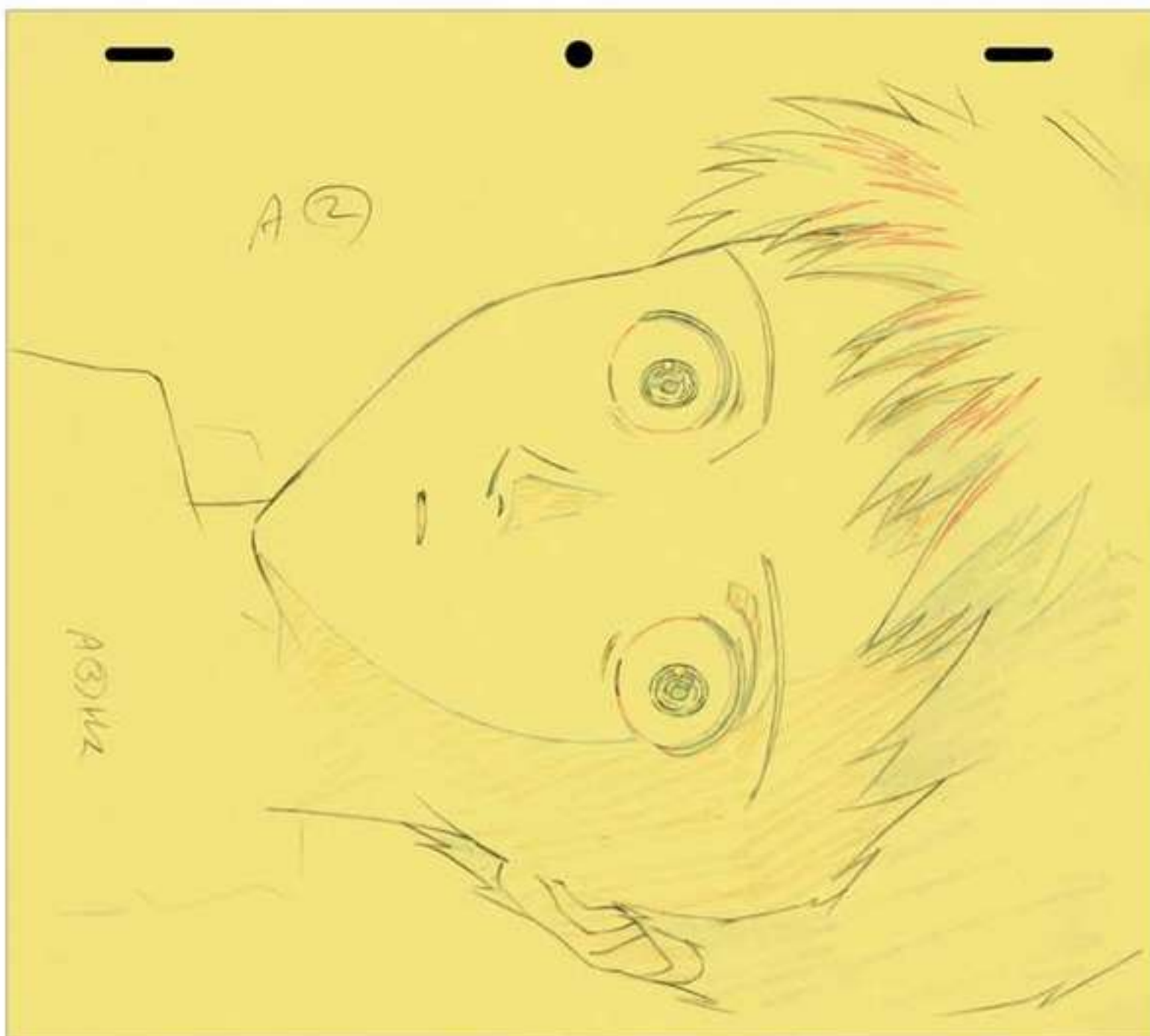

PRODUCTION I.G
EVA #26

S. G 473, 476, 481

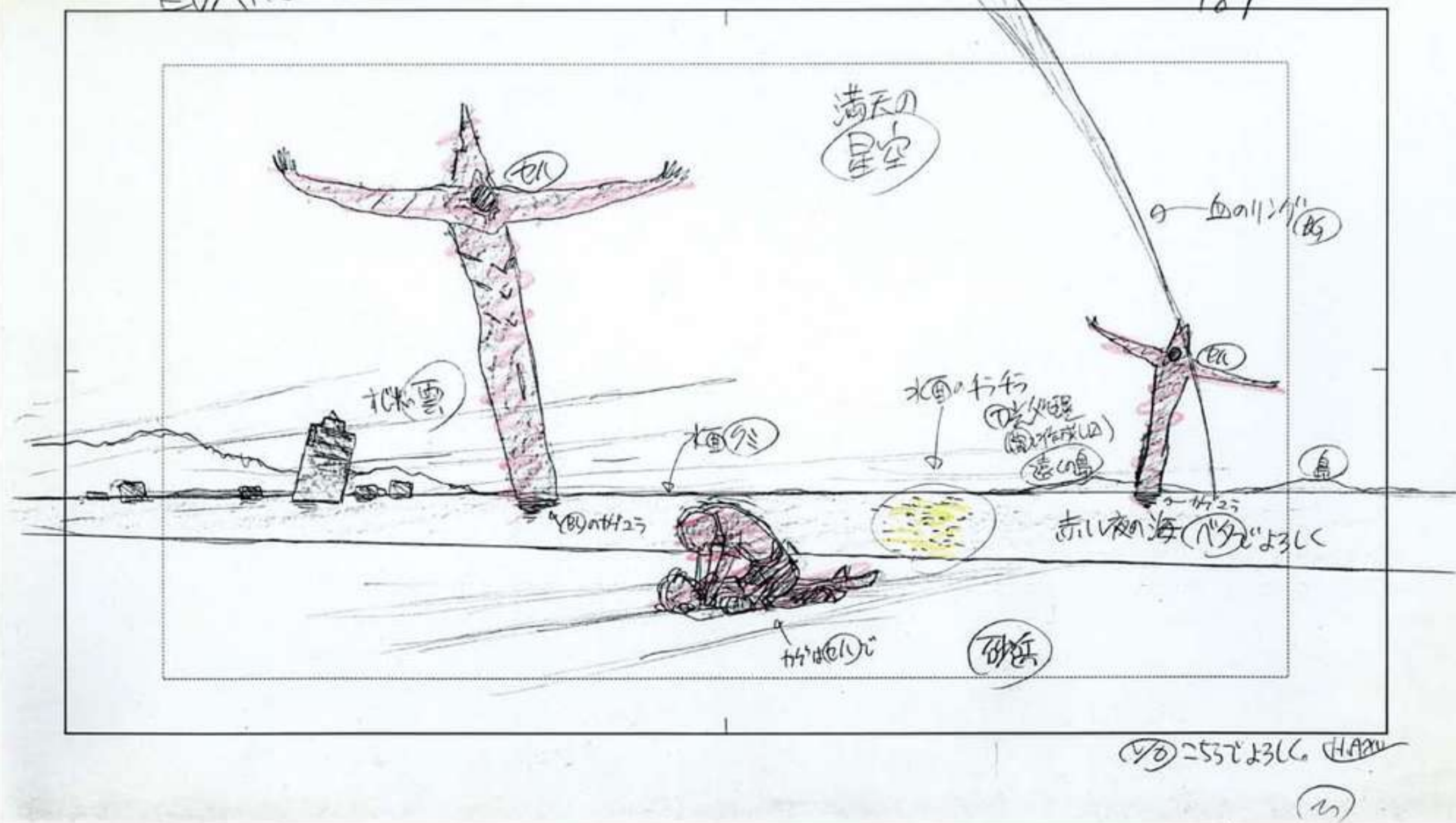

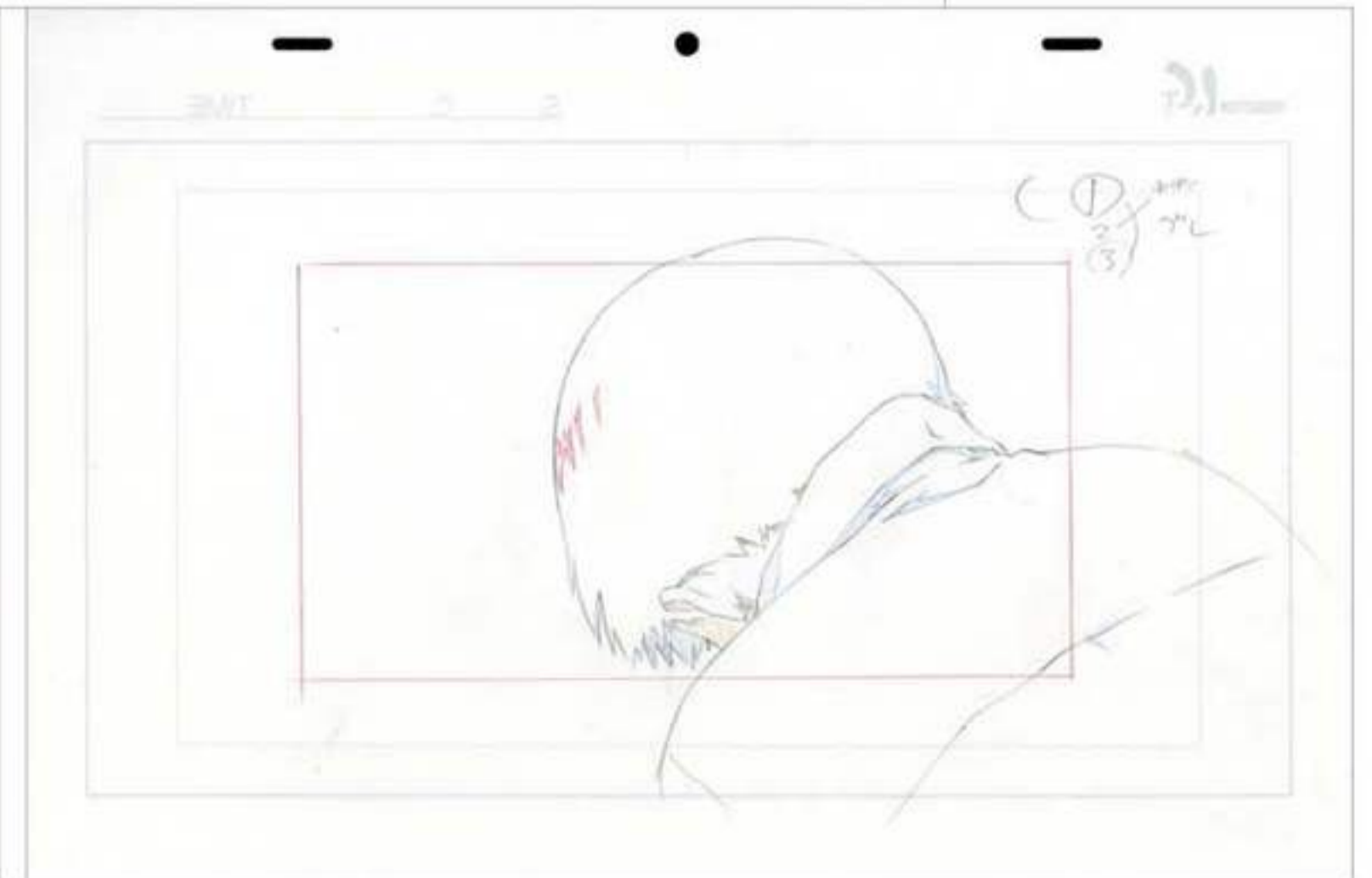



新世紀エヴァンゲリオン
劇場版原画集
下巻

Groundwork of EVANGELION

Groundwork of EVANGELION The Movie 2

新世紀エヴァンゲリオン劇場版原画集 下巻

- この電子書籍は、2002年に刊行された『新世紀エヴァンゲリオン 劇場版原画集 下巻』を基に制作しました。
- ご覧になる端末機器の種類により、表示に差異が生じることがあります。あらかじめご了承ください。
- 本作品の全部または一部を著作権者ならびに株式会社カラー、株式会社グランドワークス：に無断で複製（コピー）、転載、公衆送信することを禁止します。改ざん、改変などの行為も禁止します。また、有償・無償にかかわらず本作品を第三者に譲渡することはできません。

監修：庵野秀明

カバーイラスト：平松禎史

編集：「新世紀エヴァンゲリオン 劇場版原画集」編集部

発行：株式会社カラー <https://www.khara.co.jp>

販売：株式会社グランドワークス：

東京都杉並区西荻北 3-30-11 パルファンビル 2F

EVANGELION STORE <https://www.evastore.jp/>

© カラー / EVA 製作委員会

禁 無断転載・複製

